

User Guide



ExStik™ Model RE300

Waterproof ORP Meter

Patent Pending

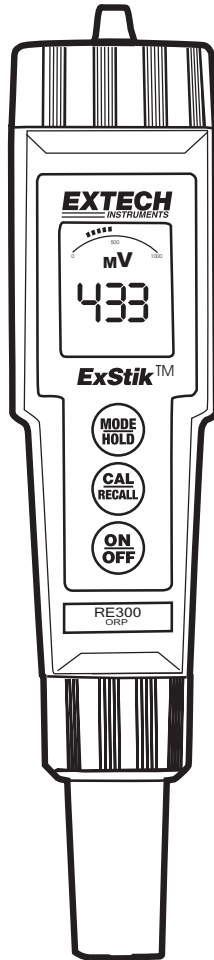

ExStik™ Description

Front Panel Controls

1. Battery compartment cap
 2. LCD Display
 3. MODE button
 4. CAL button (unused on RE300)
 5. ON/OFF button
 6. Electrode collar
 7. Electrode
- (Electrode cap is not shown)

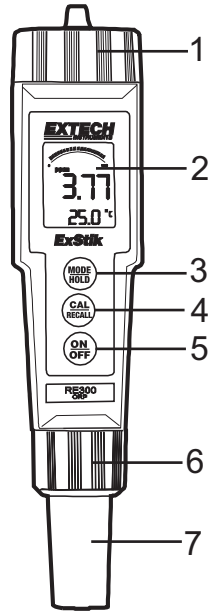

Display Description

1. Reading
2. Units
3. Bargraph
4. Data Hold
5. Scale
6. Low Battery

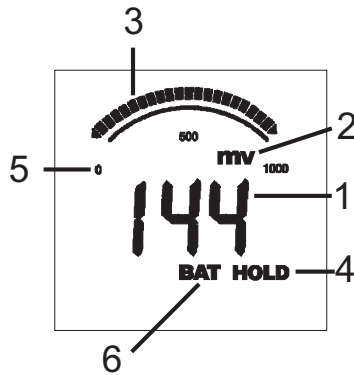

Operation

Getting Started

White KCL crystals may be present on the electrode. These crystals will dissolve in the soak or they can be simply rinsed with tap water

When the RE300 is turned on, it enters the Automatic Calibration mode. 'SELF' and 'CAL' will appear on the LCD while calibration is in progress. After the calibration is complete, 'SELF' and 'CAL' will extinguish and both the main display and bargraph will read ORP in mV units. The bargraph reads 0mV (far left), 500mV (center), and 1000mV (far right).

ORP Testing

1. Remove cap from the electrode and press the ON/OFF button to switch the RE300 on.
2. Dip the electrode 1/2" to 1" into the test solution. Stir once and let the reading stabilize for 1 to 3 minutes.
3. Note the ORP or press MODE to freeze the reading. The HOLD display icon will appear along with the held reading. The held reading will be stored in the next 15-reading storage location (see below). Press the MODE key to return to normal operation.
4. Press the ON/OFF button to turn the RE300 off. If you do not press a button for 10 minutes the RE300 shuts off automatically.

15-Reading Measurement Storage

1. Press the MODE button to store a reading. The LCD will briefly display the memory location number and then the value stored (Data Hold will activate).
2. Press MODE again to return to normal operation. Repeat step 1 above to store the next reading and so on.
3. If an attempt is made to store more than 15 readings, the stored readings (starting with the first reading) will be overwritten.

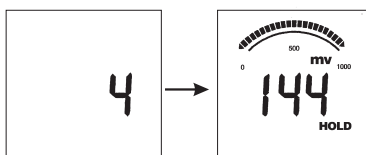

Recalling Stored Readings

Note: First ensure that the HOLD symbol is not displayed. If it is, exit the HOLD function by pressing the MODE button.

1. Press the CAL button once and then press the MODE button immediately after CAL is displayed; the location number (1 through 15) will flash. If the CAL mode is accidentally accessed (display flashing), press the CAL button again to exit.
2. The last stored reading taken will be displayed first. To advance through the stored readings, press the MODE button. The location number is displayed first, followed by the reading stored in that location.
3. To exit the storage mode, press the CAL button and the ExStik™ will return to normal operation.

Measurement and Display Considerations

- If the unit appears to be locked (display frozen). It is possible that the Data Hold mode has been inadvertently accessed by pressing the MODE button. Simply press the MODE button again or turn the meter off and restart if the display appears frozen.
- If the meter does latch up and no button presses revive it, remove the batteries and restart.
- Note that if the batteries are removed, any stored readings will be discarded. Factory calibration data for all models will be retained, however.

Replacing the Electrode

To preserve Electrode life keep the sponge in the protective cap soaked with tap water when not in use (store vertically).

DO NOT USE DE-IONIZED WATER.

1. To remove an electrode, unscrew and completely remove the electrode collar (turn the collar counter-clockwise to remove).
2. Gently rock the electrode from side to side, pulling it downwards, until it disconnects from the meter.
3. To attach an electrode, carefully plug the electrode into the meter socket (note that the electrode connector is keyed, ensuring proper connection).
4. Tighten the electrode collar firmly enough to make a good seal (a rubber gasket seals the electrode with the meter).

Powering the ExStik™

The ExStik™ uses four (4) CR2032 batteries (included).. If the batteries are weak, the 'BAT' indicator appears on the LCD. Press the ON/OFF key to turn the ExStik™ on or off. The auto power off feature shuts the ExStik™ off automatically after 10 minutes of inactivity to preserve battery life.

Battery Replacement

1. Twist off the battery compartment cap
2. Replace the four (4) 2032 batteries observing polarity.
3. Replace the battery compartment cap

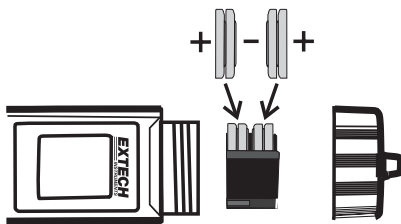

Optional Accessories

- Replacement ORP electrode (Part Number: RE305)

Specifications

Display	Multifunction LCD with Bargraph
Operating conditions	32 to 122°F (0 to 50°C) / < 80% RH
ORP Range / Accuracy	± 999mV / ± 4mV
Measurement storage	15 tagged (numbered) readings
Power	Four (4) CR2032 button batteries
Low battery indication	'BAT' appears on the LCD
Auto power off	After 10 minutes of inactivity

Warranty

EXTECH INSTRUMENTS CORPORATION warrants this instrument to be free of defects in parts and workmanship for **one year** from date of shipment (a six month limited warranty applies to sensors and cables). If it should become necessary to return the instrument for service during or beyond the warranty period, contact the Customer Service Department at (781) 890-7440 ext. 210 for authorization or visit our website www.extech.com for contact information. A Return Authorization (RA) number must be issued before any product is returned to Extech. The sender is responsible for shipping charges, freight, insurance and proper packaging to prevent damage in transit. This warranty does not apply to defects resulting from action of the user such as misuse, improper wiring, operation outside of specification, improper maintenance or repair, or unauthorized modification. Extech specifically disclaims any implied warranties or merchantability or fitness for a specific purpose and will not be liable for any direct, indirect, incidental or consequential damages. Extech's total liability is limited to repair or replacement of the product. The warranty set forth above is inclusive and no other warranty, whether written or oral, is expressed or implied.

Calibration and Repair Services

Extech offers repair and calibration services for the products we sell. Extech also provides NIST certification for most products. Call the Customer Service Department for information on calibration services available for this product. Extech recommends that annual calibrations be performed to verify meter performance and accuracy.



Support line (781) 890-7440

Technical support: Extension 200; E-mail: support@extech.com

Repair & Returns: Extension 210; E-mail: repair@extech.com

Product specifications subject to change without notice

For the latest version of this User's Guide, Software updates, and other up-to-the-minute product information, visit our website: www.extech.com
Extech Instruments Corporation, 285 Bear Hill Rd., Waltham, MA 02451

Copyright © 2005 Extech Instruments Corporation

All rights reserved including the right of reproduction in whole or in part in any form.