



**Coriolis**  
Mass Flow Meters

## Coriolis Flow Meters

RCT1000 with RCS005...300 Sensors



**Badger Meter**

CRL-UM-00038-EN-08 (February 2017)

# User Manual



---

## CONTENTS

Introduction . . . . .	9
Coriolis Mass Meter . . . . .	9
Badger Meter Coriolis Mass Meter . . . . .	9
Badger Meter Software . . . . .	9
Purpose of this Document . . . . .	9
Safety . . . . .	9
Safety Symbol Explanations . . . . .	9
Electrical Symbol Explanations . . . . .	10
Safety Precautions . . . . .	10
Product Labels . . . . .	11
General Safety . . . . .	11
Hazardous Location . . . . .	11
RCS Sensor Dimensions . . . . .	13
Sensor Dimensions, RCS005 . . . . .	13
Sensor Dimensions, RCS008 . . . . .	13
Sensor Dimensions, RCS018...RCS300 . . . . .	14
RCTX Transmitter Dimensions . . . . .	14
RCTX Remote Mount Electronics Enclosure Dimensions . . . . .	15
RCTN Transmitter Dimensions . . . . .	16
Installation . . . . .	18
Product Unpacking and Inspection . . . . .	18
Transporting the Meter . . . . .	18
Sensor Installation . . . . .	19
All RCS Sensors . . . . .	19
Sensor Pipeline Mounting Recommendations . . . . .	20
RCS005 and RCS008 Sensor Installation . . . . .	23
Transmitter Installation . . . . .	24
RCTX Transmitters . . . . .	24
RCTN Transmitter . . . . .	26
Grounding/Earthing . . . . .	26
Power Connections . . . . .	28
RCTX DC Power Connections . . . . .	28

RCTN AC Power Connections . . . . .	28
RCTN DC Power Connections . . . . .	29
Transmitter-to-Sensor Connections . . . . .	31
RCTX-to-Sensor Connections . . . . .	31
RCTN-to-Sensor Connections . . . . .	31
Conduit Outlet Box for Remote Mount . . . . .	32
RCTN for General Safety Areas . . . . .	33
Inputs / Outputs . . . . .	34
RCTX Transmitters . . . . .	34
RCTN Transmitters . . . . .	37
Basic Operation . . . . .	40
Using the Keypad . . . . .	40
Conventions . . . . .	40
The Active Line . . . . .	41
Button Functions Based on Location In Menus . . . . .	41
Final Checks . . . . .	46
Startup Screens . . . . .	46
Menu Map . . . . .	47
Navigation During an Alarm Condition . . . . .	48
WARNING Help . . . . .	48
System Passwords . . . . .	48
Default Passwords . . . . .	48
Changing a Password PIN . . . . .	49
Sensor Check . . . . .	49
Initial Zeroing Procedure . . . . .	50
Priming for Zero . . . . .	50
Zeroing the System . . . . .	50
Home Screen Setup . . . . .	51
Enable/Disable Hidden Menus . . . . .	51
HMI Examples . . . . .	52
Editing Parameter Units, Values and Resolution . . . . .	52
Backing Up the Transmitter . . . . .	53
Automatic Backup . . . . .	53
Manual Backup . . . . .	53
Backup Using RCT Console Software . . . . .	53



---

Backup Enabled Parameters. . . . .	54
Reset Totals Help. . . . .	54
Flow Direction . . . . .	54
Output Configuration. . . . .	55
Current Outputs . . . . .	55
Frequency, Pulse and PWM Outputs. . . . .	56
PID. . . . .	57
Modify the PID Control Settings . . . . .	57
PID Control Explanations . . . . .	57
Enabling and Setting Values on the 4...20 mA Output Port . . . . .	58
User Alarms . . . . .	59
Communication Wiring and Setup . . . . .	60
EIA-485 Port . . . . .	60
USB Programming Port . . . . .	60
EIA-485 / USB Configuration. . . . .	60
Optional HART Communication Card . . . . .	61
Optional Ethernet Communication Card . . . . .	61
Ethernet Configuration . . . . .	62
Communications Protocols . . . . .	64
Modbus RTU. . . . .	64
HART . . . . .	64
EtherNet/IP . . . . .	64
Identity Object (01HEX – 1 Instance) . . . . .	65
Message Router Object (02HEX – 1 Instance) . . . . .	65
Assembly Object (04HEX – 2 Instances) . . . . .	65
TCP Object (F5 <sub>HEX</sub> – 1 Instance) . . . . .	68
Ethernet Link Object (F6 <sub>HEX</sub> – 1 Instance) . . . . .	69
Modbus TCP/IP Addressing . . . . .	70
Modbus CIP Model Addressing . . . . .	73
Troubleshooting . . . . .	76
Identifying System Faults. . . . .	76
Red/Green LED Diagnostics . . . . .	76
Error Messages . . . . .	77
Troubleshooting Symptoms. . . . .	78
Part Number Construction. . . . .	80

Sensors 005 and 008 ONLY. . . . .	80
Sensor Part Number (Remote Mount Transmitter Option) . . . . .	80
General Safety Transmitter Part Number (Remote Mount) . . . . .	81
Hazardous Location Transmitter Part Number (Remote Mount) . . . . .	81
Integral Mount Transmitter with Sensor Part Number Construction. . . . .	82
Specifications . . . . .	83
System with RCS005/RCS008 Sensors. . . . .	83
Flow Rate Specifications . . . . .	83
RCS005/RCS008 Sensors Specifications. . . . .	83
System Specifications. . . . .	84
Flow Rate Specifications . . . . .	84
Sensor Specifications . . . . .	84
Transmitters . . . . .	85
Cable Kits . . . . .	86
Parameters by Address (addr). . . . .	87
Parameters by Menu Location . . . . .	92
Main Menu > Measurement . . . . .	92
Main Menu > System > Sensor . . . . .	92
Main Menu > System > IO Stat . . . . .	93
Main Menu > System > About . . . . .	93
Main Menu > Set Up > Calibration > Flow . . . . .	94
Main Menu > Set Up > Calibration > Density . . . . .	94
Main Menu > Set Up > Calibration > Temperature. . . . .	94
Main Menu > Set Up > Calibration > Driver . . . . .	95
Main Menu > Set Up > Calibration > Zero Calibration . . . . .	95
Main Menu > Set Up > Calibration > Primary . . . . .	95
Main Menu > Set Up > System IO > Current1 Setup. . . . .	96
Main Menu > Set Up > System IO > Current2 Setup. . . . .	96
Main Menu > Set Up > System IO > Current3 Setup. . . . .	97
Main Menu > Set Up > System IO > Frequency Setup. . . . .	97
Main Menu > Set Up > System IO > Com Ports . . . . .	98
Main Menu > Set Up > System IO > Relays. . . . .	98
Main Menu > Set Up > System IO > Analog Input . . . . .	98
Main Menu > Set Up > Menus . . . . .	98
Main Menu > Set Up > Program . . . . .	99
Main Menu > Set Up > Password. . . . .	99

---

Main Menu > Set Up > Display . . . . .	100
Main Menu > Batch . . . . .	100
Main Menu > PID. . . . .	101
Main Menu > Total. . . . .	101
Main Menu > Concentration . . . . .	101
Main Menu > Application . . . . .	102
Main Menu > Net Flow . . . . .	102
Main Menu > Alarms > Alarm-A . . . . .	102
Main Menu > Alarms > Alarm-B . . . . .	102
Main Menu > Alarms > Alarm-C . . . . .	103
Main Menu > Alarms > Alarm-D . . . . .	103
Main Menu > Alarms > Alarm-E. . . . .	103
Main Menu > Alarms > Alarm-F. . . . .	103
Main Menu > Alarms > EAlmOut . . . . .	103
RCT Console Basics . . . . .	104
Minimum System Requirements . . . . .	104
Setup . . . . .	104
Glossary . . . . .	108



## INTRODUCTION

### Coriolis Mass Meter

As a mass flow meter, a Coriolis mass meter directly measures the mass flow, temperature and density rather than volumetric flow. Since density varies with temperature, pressure and other fluid attributes, direct measurement of mass is typically more accurate than deriving the mass from a volumetric flow meter. Because a Coriolis meter measures density, it is suitable for measuring homogeneous fluids that consist of two liquids.

In a Coriolis mass meter, there are virtually no obstructions in the fluid path making the meter more appropriate for viscous fluids. Since there are no internal moving parts, a Coriolis mass meter requires little maintenance.

### Badger Meter Coriolis Mass Meter

In addition to measuring mass flow and density, the Badger Meter Coriolis mass meter does batching and PID control which can be linked to discrete and analog inputs and outputs.

### Badger Meter Software

The RCT Console software can be installed on a computer which connects to the transmitter through the USB programming port. Along with meter configuration, the RCT Console software provides logging, trending and diagnostic capabilities. The RCT Console software is included with the Coriolis mass meter.

## PURPOSE OF THIS DOCUMENT

The purpose of this document is to provide you with an overview of the installation, wiring and basic configuration of the Coriolis RCT1000 flow meter. For detailed information, see the *Coriolis RCT1000 User Manual*, which can be found on the USB memory stick included with the meter. You can also download the manual at [www.badgermeter.com](http://www.badgermeter.com).

## SAFETY

### Safety Symbol Explanations

** DANGER**

**INDICATES A HAZARDOUS SITUATION, WHICH, IF NOT AVOIDED IS ESTIMATED TO BE CAPABLE OF CAUSING DEATH OR SERIOUS PERSONAL INJURY.**





** WARNING**

**INDICATES A HAZARDOUS SITUATION, WHICH, IF NOT AVOIDED COULD RESULT IN SEVERE PERSONAL INJURY OR DEATH.**

** CAUTION**

**INDICATES A HAZARDOUS SITUATION, WHICH, IF NOT AVOIDED IS ESTIMATED TO BE CAPABLE OF CAUSING MINOR OR MODERATE PERSONAL INJURY OR DAMAGE TO PROPERTY.**

## Electrical Symbol Explanations

Electrical Symbols					
Function	Direct Current	Alternating Current	Earth (Ground)	Protective Ground	Chassis Ground
Symbol					

RCT1000 transmitters employ modular construction and provide electrical safety for the operator.

## Safety Precautions

### **⚠ DANGER**

**THE POWER SUPPLY BOARD CAN HAVE LINE VOLTAGES APPLIED TO IT. DISCONNECT ELECTRICAL POWER BEFORE OPENING THE INSTRUMENT ENCLOSURE. USE WIRING PRACTICES THAT CONFORM TO LOCAL AND NATIONAL CODES WITHIN THE REGION WHERE THE PRODUCT IS INSTALLED. [FOR EXAMPLE: THE NATIONAL ELECTRICAL CODE® HANDBOOK IN THE U.S.; CANADIAN ELECTRIC (CE) CODE IN CANADA].**

### **⚠ CAUTION**

**IF THE EQUIPMENT IS USED IN A MANNER NOT SPECIFIED BY THE MANUFACTURER, THE PROTECTION PROVIDED BY THE EQUIPMENT MAY BE IMPAIRED.**

# PRODUCT LABELS

## General Safety

All RCTN transmitters for general safety areas have the labels shown below.

### RCTN Transmitter Labels

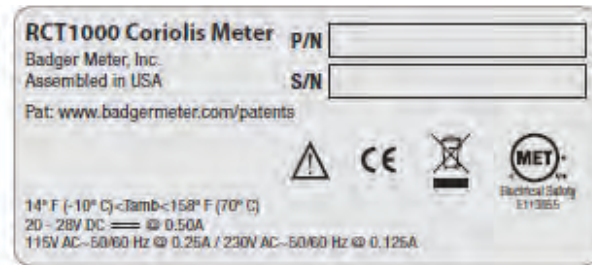

Figure 1: RCTN label

### RCS Sensor Tags

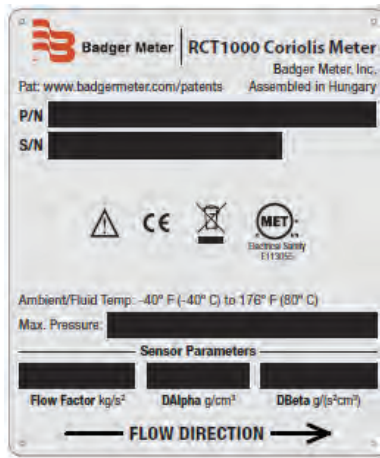

Figure 2: RCS sensor tag example

### Hazardous Location

Sensors with integral mount transmitters have a single tag on the sensor. The specific certifications listed on the tag depend on the sensor part number.

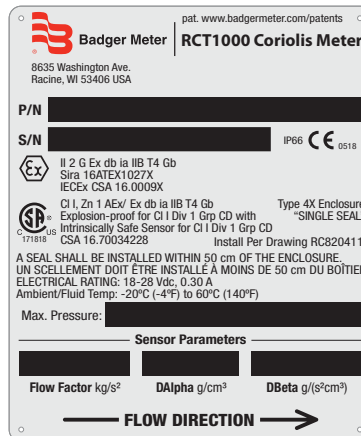

Figure 3: Hazardous location sensor tag examples

## Remote Sensor

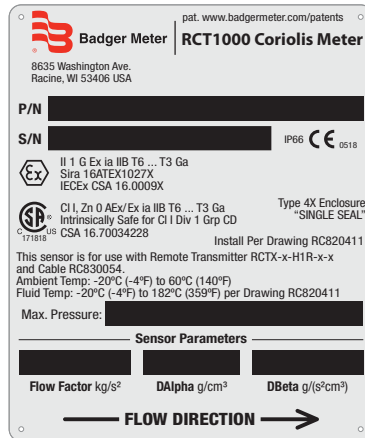

Figure 4: Remote sensor tag example

## Remote Transmitter

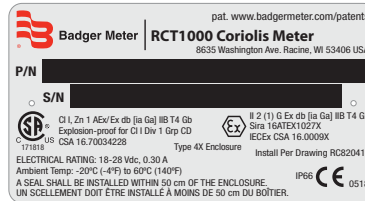

Figure 5: Remote transmitter tag example



# RCS SENSOR DIMENSIONS

## Sensor Dimensions, RCS005

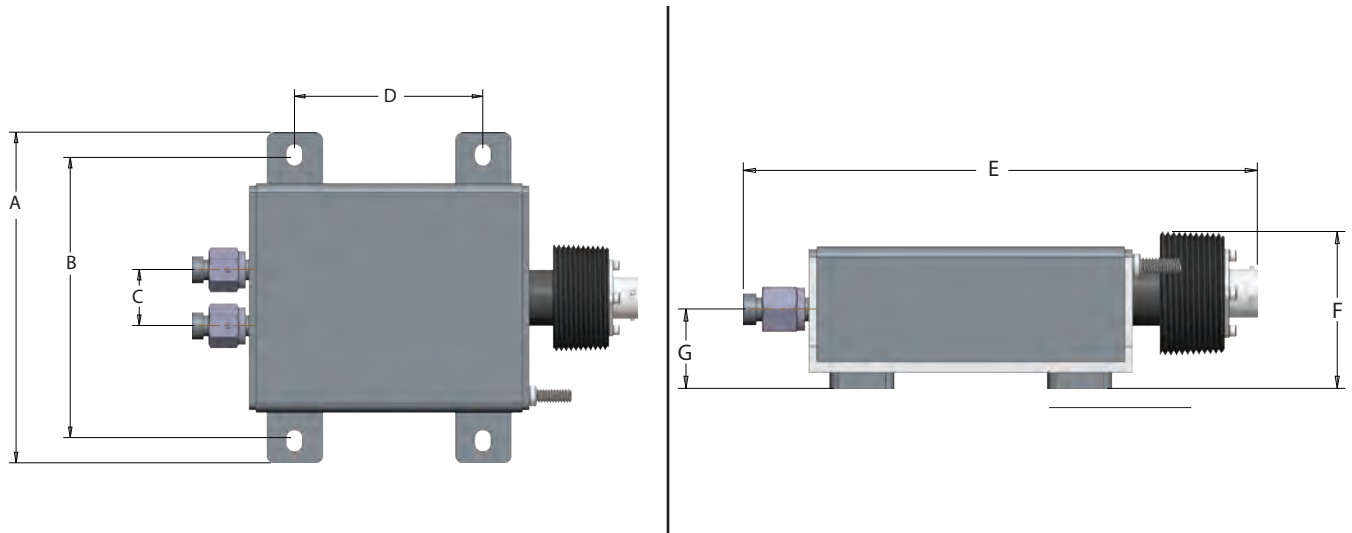

Figure 6: RCS005 dimensions

Sensor	Nominal Size	A	B	C	D	E	F	G
RCS005	1/4 in.	5.90 in. (149.9 mm)	5.00 in. (127 mm)	1.00 in. (25.4 mm)	3.60 in. (85.3 mm)	7.93 in. (201.7 mm)	2.42 in. (61.6 mm)	1.23 in. (31.2 mm)

## Sensor Dimensions, RCS008

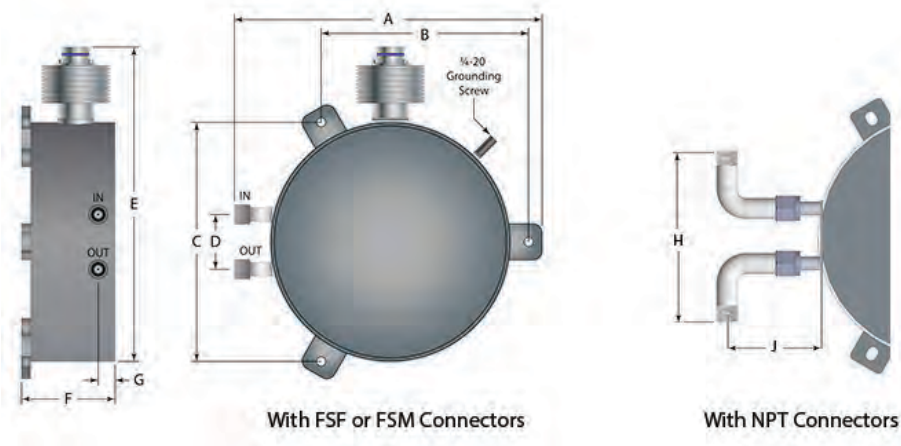

Figure 7: RCS008 dimensions

Sensor	Nominal Size	A	B	C	D	E	F	G	H	J
RCS008	1/4 in.	8.48 in. (215.3 mm)	5.72 in. (145.3 mm)	6.60 in. (167.7 mm)	1.50 in. (38.1 mm)	8.70 in. (221 mm)	2.67 in. (67.8 mm)	0.98 in. (24.9 mm)	4.65 in. (118 mm)	2.48 in. (63 mm)

### Sensor Dimensions, RCS018...RCS300

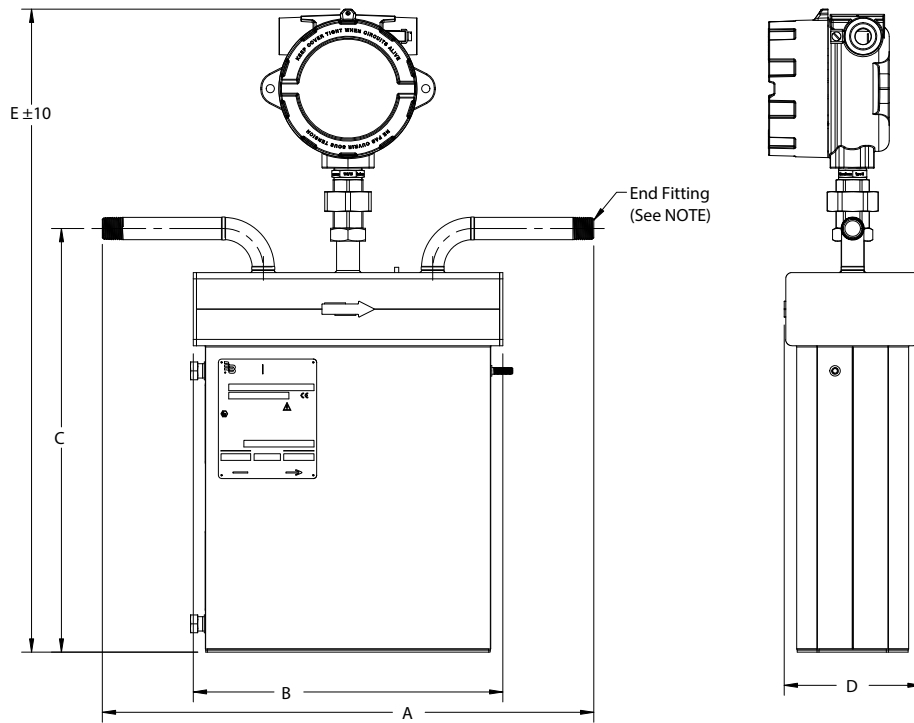

Figure 8: Large sensor dimensions

Sensor	Nominal Size	A <sup>1</sup>	B	C	D	E (Standard)	E (Remote)
RCS018	1/2 in.	13.6 in. (346 mm) <sup>1</sup>	7.1 in. (180 mm) <sup>1</sup>	8.5 in. (217 mm) <sup>2</sup>	4.4 in. (113 mm) <sup>2</sup>	19.3 in. (489 mm)	18.3 in. (464 mm)
RCS025	1/2 in.	16.0 in. (406 mm) <sup>1</sup>	9.0 in. (228 mm) <sup>1</sup>	9.9 in. (253 mm) <sup>2</sup>	4.4 in. (113 mm) <sup>2</sup>	20.7 in. (525 mm)	19.7 in. (500 mm)
RCS050	1/2 in.	18.5 in. (470 mm) <sup>1</sup>	11.6 in. (296 mm) <sup>1</sup>	15.9 in. (405 mm) <sup>2</sup>	5.1 in. (131 mm) <sup>2</sup>	24.2 in. (615 mm)	23.2 in. (590 mm)
RCS100	1 in.	23.2 in. (590 mm) <sup>1</sup>	16.8 in. (426 mm) <sup>1</sup>	27.6 in. (700 mm) <sup>2</sup>	6.4 in. (163 mm) <sup>2</sup>	34.3 in. (870 mm)	33.3 in. (845 mm)
RCS200	2 in.	26.4 in. (670 mm) <sup>2</sup>	18.5 in. (472 mm) <sup>2</sup>	28.6 in. (726 mm) <sup>3</sup>	7.9 in. (203 mm) <sup>3</sup>	33.4 in. (848 mm)	32.4 in. (823 mm)
RCS300	3 in.	40.9 in. (1040 mm) <sup>2</sup>	28.7 in. (728 mm) <sup>2</sup>	40.4 in. (1028 mm) <sup>3</sup>	9.5 in. (243 mm) <sup>3</sup>	45.3 in. (1150 mm)	44.3 in. (1125 mm)

<sup>1</sup> ± 0.12 in (3 mm)

<sup>2</sup> ± 0.15 in (4 mm)

<sup>3</sup> ± 0.24 in (6 mm)

**NOTE:** End fittings can be NPT (shown), Class 150 or Class 300 ANSI flanges, or other; dimensions A and C do not change.

### RCTX TRANSMITTER DIMENSIONS

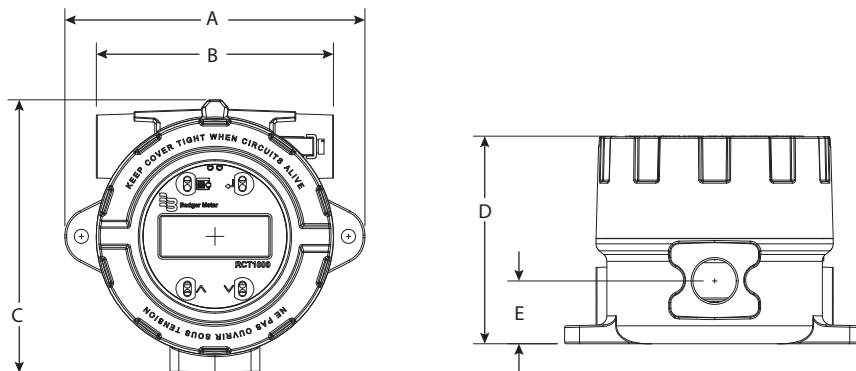

Figure 9: RCTX dimensions

A	B	C	D	E
6.57 in. (167 mm)	5.20 in. (132 mm)	5.98 in. (152 mm)	4.57 in. ± 0.12 in. (116 mm ± 3 mm)	1.37 in. (35 mm)

## RCTX REMOTE MOUNT ELECTRONICS ENCLOSURE DIMENSIONS

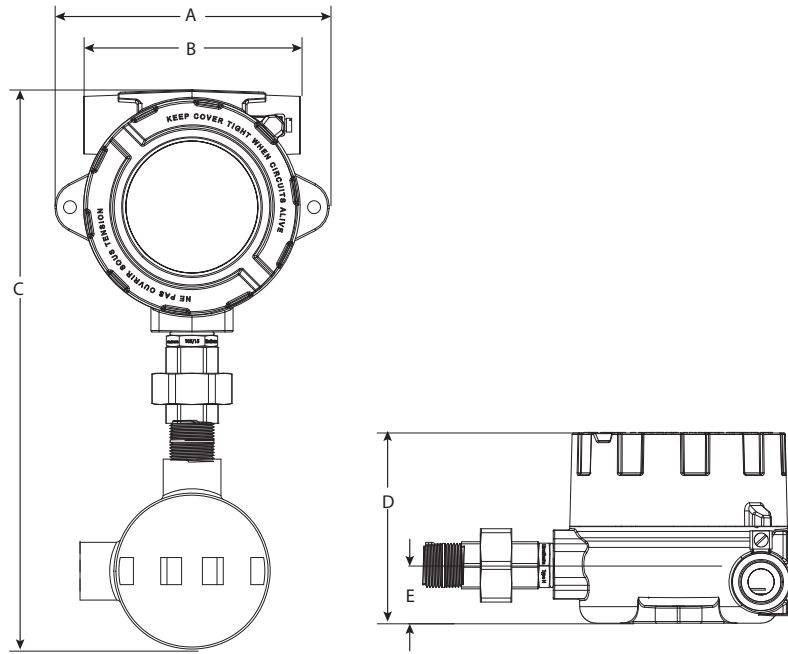

Figure 10: RCTX remote mount dimensions

<b>A</b>	<b>B</b>	<b>C</b>	<b>D</b>	<b>E</b>
6.57 in. (167 mm)	5.20 in. (132 mm)	13.43 in. (341 mm)	4.57 in. ± 0.12 in. (116 mm ± 3 mm)	1.37 in. (35 mm)

## RCTN TRANSMITTER DIMENSIONS

**NOTE:** Mounting hardware included (wall mount bracket, pipe mount bracket and transmitter/bracket fasteners)

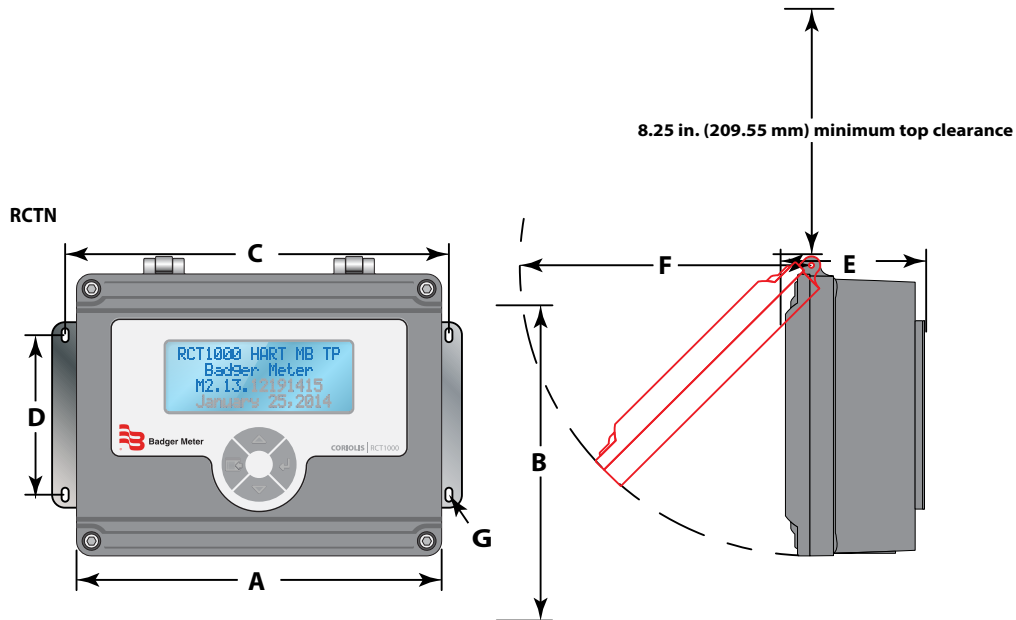

Figure 11: Transmitter mounting dimensions

A	B	C	D	E	F
9.80 in. (249.9 mm)	8.00 in. (203.2 mm)	10.30 in. (261.6 mm)	4.30 in. (109.2 mm)	3.66 in. (93.0 mm)	8.32 in. (211.2 mm)

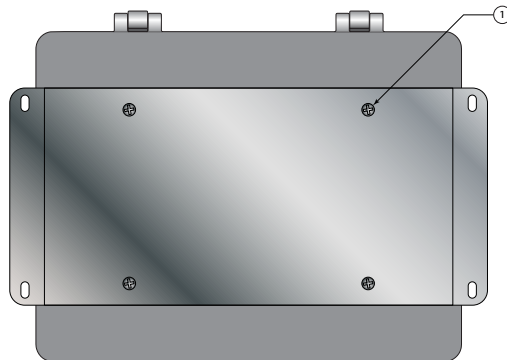

Figure 12: Back plate mounting

1	Screw	#8-32 UNC-2B
---	-------	--------------

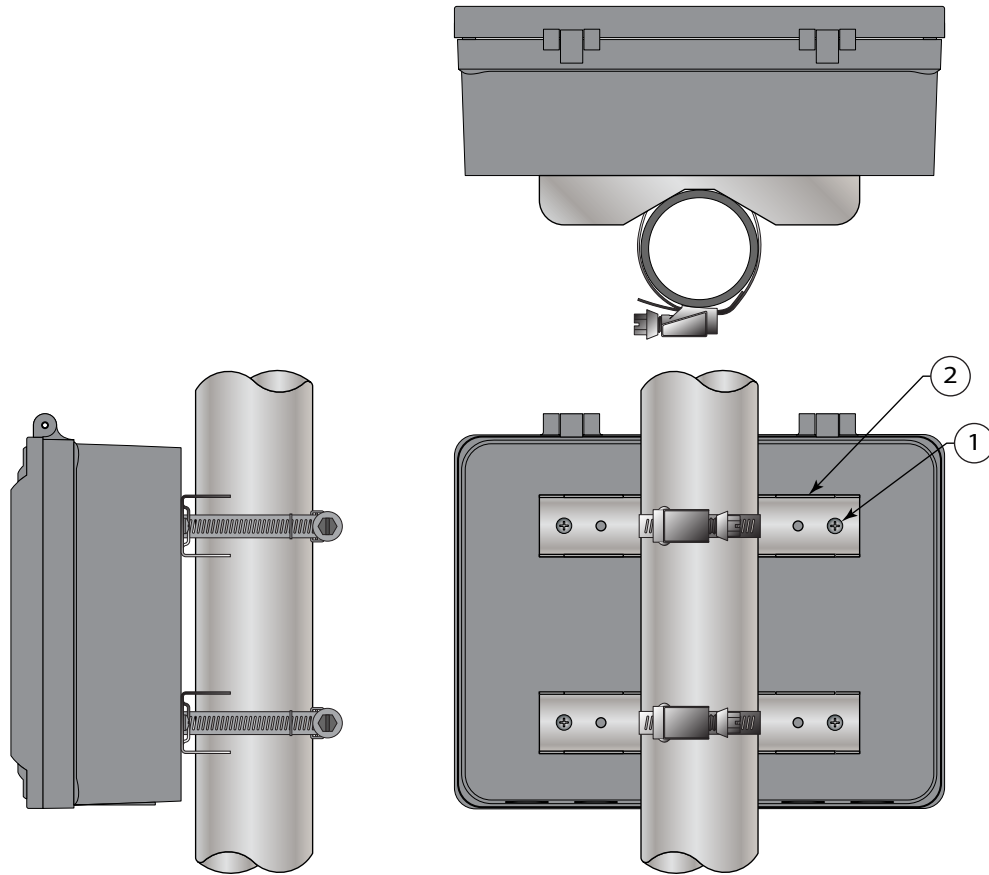

Figure 13: Pipe mounting

1	Screw	#8-32 UNC-2B
2	Bracket	Pipe mounting

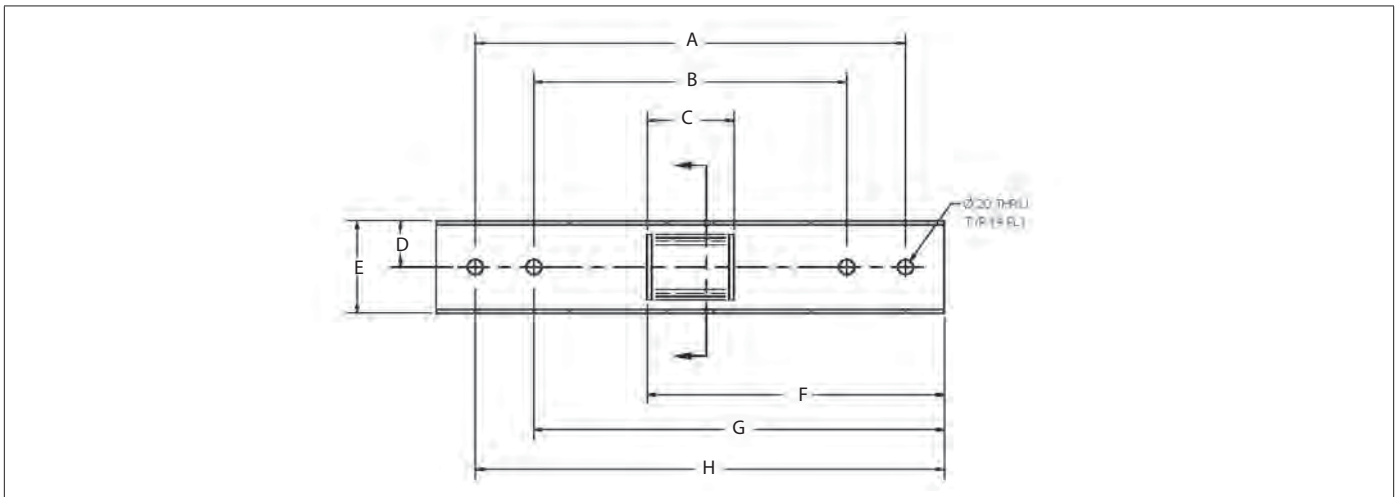

Figure 14: Pipe mounting dimensions

A	B	C	D	E	F	G	H
5.50 in. (139.7 mm)	4.00 in. (101.6 mm)	1.11 in. (28.2 mm)	0.625 in. (15.9 mm)	1.25 in. (31.8 mm)	3.80 in. (96.5 mm)	5.25 in. (133.6 mm)	6.00 in. (152.4 mm)

## INSTALLATION

In general, the following steps are required to install and put the meter into service.

1. Unpack meter components and transport to the installation location.
2. Install the transmitter and sensor.
3. Connect the signal cable between the transmitter and the sensor, if necessary.
4. Install any required I/O wiring.
5. Wire power to the transmitter.
6. Power up the transmitter.
7. Perform initial zeroing of the meter.
8. Perform firmware setup starting at the *Home* screen.
9. Put the meter into service.

## PRODUCT UNPACKING AND INSPECTION

Upon receipt of the product, perform the following unpacking and inspection procedures.

**NOTE:** If damage to the shipping container is evident upon receipt, request the carrier to be present when the product is unpacked.

Carefully open the shipping package and follow any instructions that may be marked on the exterior. Remove all cushioning material surrounding the product and carefully lift the product from the package.

Retain the package and all packing material for possible use in reshipment or storage.

Visually inspect the product and applicable accessories for any physical damage such as scratches, loose or broken parts or any other sign of damage that may have occurred during shipment.

**NOTE:** If damage is found, request an inspection by the carrier's agent within 48 hours of delivery and file a claim with the carrier. A claim for equipment damage in transit is the sole responsibility of the purchaser.

## TRANSPORTING THE METER

The following instructions apply to unpacking and transporting the meter to its final installation point:

- Transport the devices in the shipping containers in which they came.
- Do not remove covers or caps fitted to the process connections until immediately before installation. The covers prevent mechanical damage to the sealing faces and the ingress of foreign matter into the measuring tube during transportation and storage.
- Do not lift assembled metering systems by the transmitter housing. Use webbing slings attached around the two process connections. Do not use chains, as they could damage the housing.

### **⚠ WARNING**

**THERE IS A RISK OF INJURY IF THE MEASURING DEVICE SLIPS. THE CENTER OF GRAVITY OF THE ASSEMBLED MEASURING DEVICE MIGHT BE HIGHER THAN THE POINTS AROUND WHICH THE SLINGS ARE ATTACHED. AT ALL TIMES, THEREFORE, MAKE SURE THE DEVICE DOES NOT UNEXPECTEDLY TURN AROUND ITS AXIS OR SLIP.**

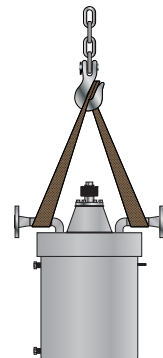

Figure 15: Transport sling

## SENSOR INSTALLATION

Before installation, configuration or operation, familiarize yourself with the equipment and operating requirements by reading all sections of this manual. Ensure the site has been thoroughly prepared and is suitable for installation.

### All RCS Sensors

#### IMPORTANT

**Remove all process connection caps and ensure process connections are open.**

1. Support and align piping connections to prevent side loading of the mating surfaces.
2. RCS018 and larger sensors are designed to be supported by the process flange connection. No additional supports are needed for meter housing.
3. To reduce the influence of pipe vibration on RCS018 and larger meters, Stauff style clamps are suggested to help with supporting process piping. RCS005 and RCS008 sensors must be securely mounted to a heavy, rigid surface, such as a concrete floor or wall.
4. Full port ball valves should be mounted on either side of meter for zero calibration purposes.
5. Control valves should be mounted downstream of the flow meter to prevent possible cavitation especially when measuring liquids with low boiling points (see *Figure 17*).
6. The meter should be installed in a section of the piping where it always remains full unless the application is designed to drain with no flow.
7. Vertical piping installations should have the flow going up through the meter (see *Figure 19*).
8. When using hose connections a short section of rigid pipe should be used on each side of the meter for proper support. The meter should not hang from hose connections (see *Figure 20* and *Figure 21*).
9. Caution should be used for fluids that harden or solidify at rest. Do not pass fluids that react together through the same flow sensor.
10. If heat tracing is used, be aware of the maximum temperature limits of the meter.
11. Use of armored hoses, as sensor vibration isolators may be required when a high amount of ambient vibration is present (see *Figure 20* and *Figure 21*).
12. Verify that particulate matter is small enough to pass through the flow sensor. A filter should be added to the system if necessary.
13. Verify that the flow sensor is earthed/grounded at the earth connector located on the sensor side. An AWG #10 or larger protective ground must be connected to the side grounding terminal for the system to work correctly (see *Figure 17*, *Figure 18* and *Figure 19*).
14. High sources of EMF should be avoided. These can be produced by large transformers, large motors and VFDs without chokes.

#### **WARNING**

**THE SENSOR IS PURGED WITH DRY NITROGEN AT THE FACTORY. THE TWO PURGE PLUGS SHOULD NOT BE REMOVED. IF THEY ARE REMOVED FOR ANY REASON, RETURN THE UNIT TO THE FACTORY TO BE RE-PURGED AND SEALED. CONSULT FACTORY FOR SUPPORT.**

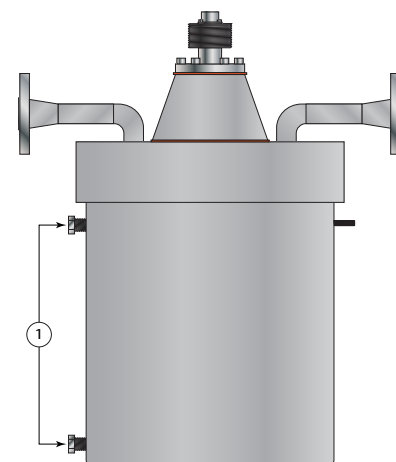

Figure 16: Purge ports

1	Port	Nitrogen purge
---	------	----------------

## Sensor Pipeline Mounting Recommendations

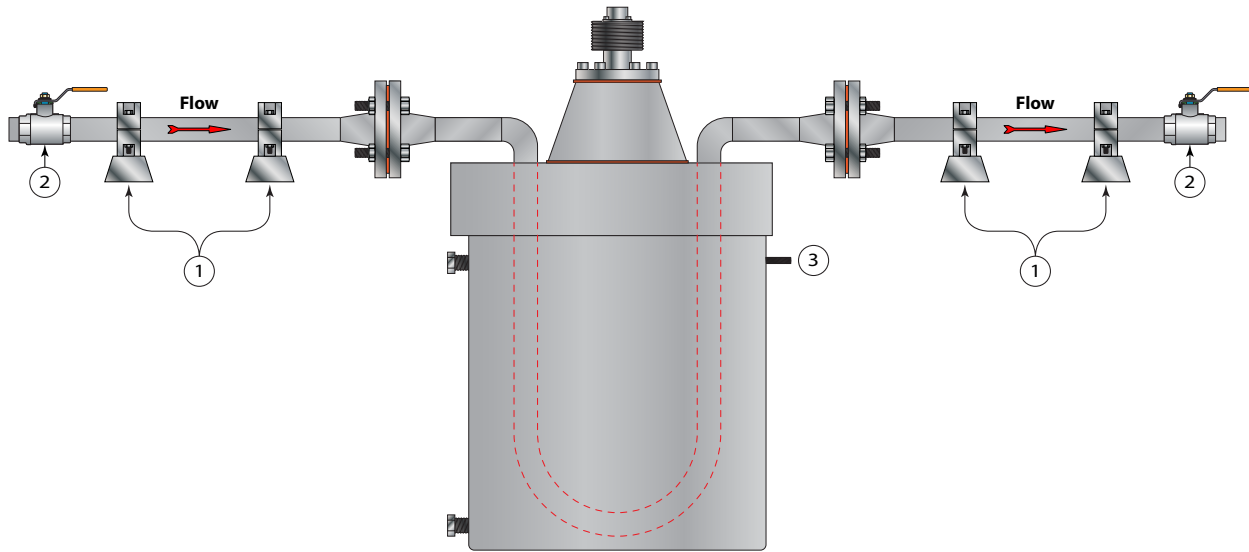

Figure 17: Tubes down (liquids)

1	Supports— <b>Customer supplied</b>	Rigid pipe supports approximately 3 and 6 pipe diameters from the end of the sensor
2	Valves— <b>Customer supplied</b>	Full port ball
3	Ground	Protective (earth), 10 AWG (4 mm <sup>2</sup> ) minimum

Vibration reducing pipe supports should be used in all applications. The mounting orientation shown in *Figure 17* is recommended for liquid applications.

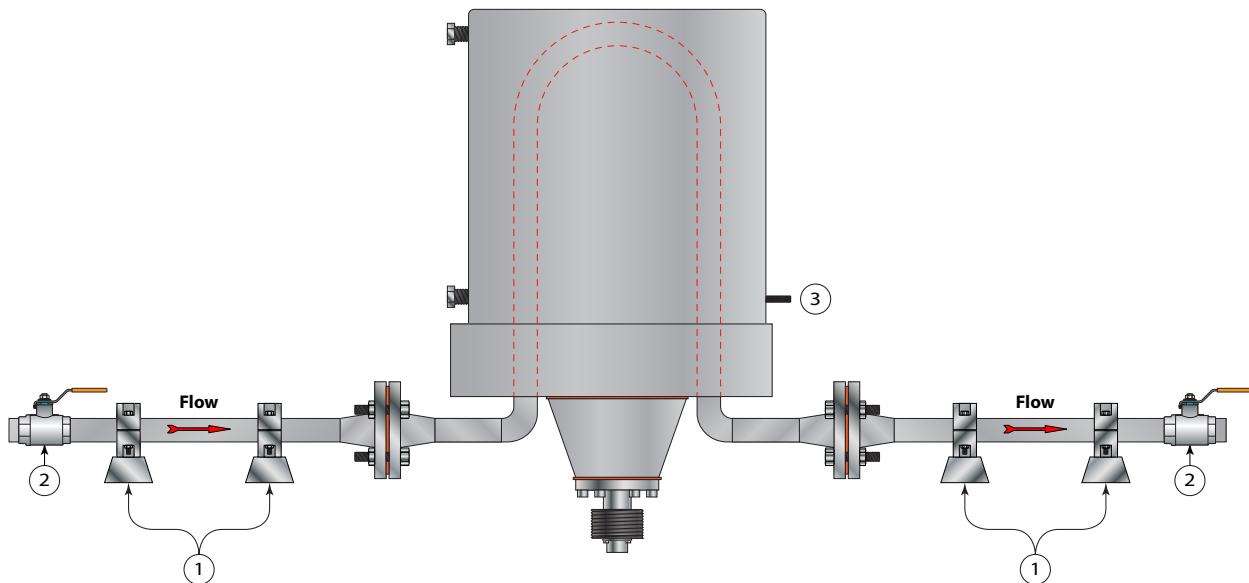

Figure 18: Tubes up (gases and slurries)

1	Supports— <b>Customer supplied</b>	Rigid pipe supports approximately 3 and 6 pipe diameters from the end of the sensor
2	Valves— <b>Customer supplied</b>	Full port ball
3	Ground	Protective (earth), 10 AWG (4 mm <sup>2</sup> ) minimum

For gas or slurry applications where condensate may be present, mount the sensor as shown in *Figure 18*.



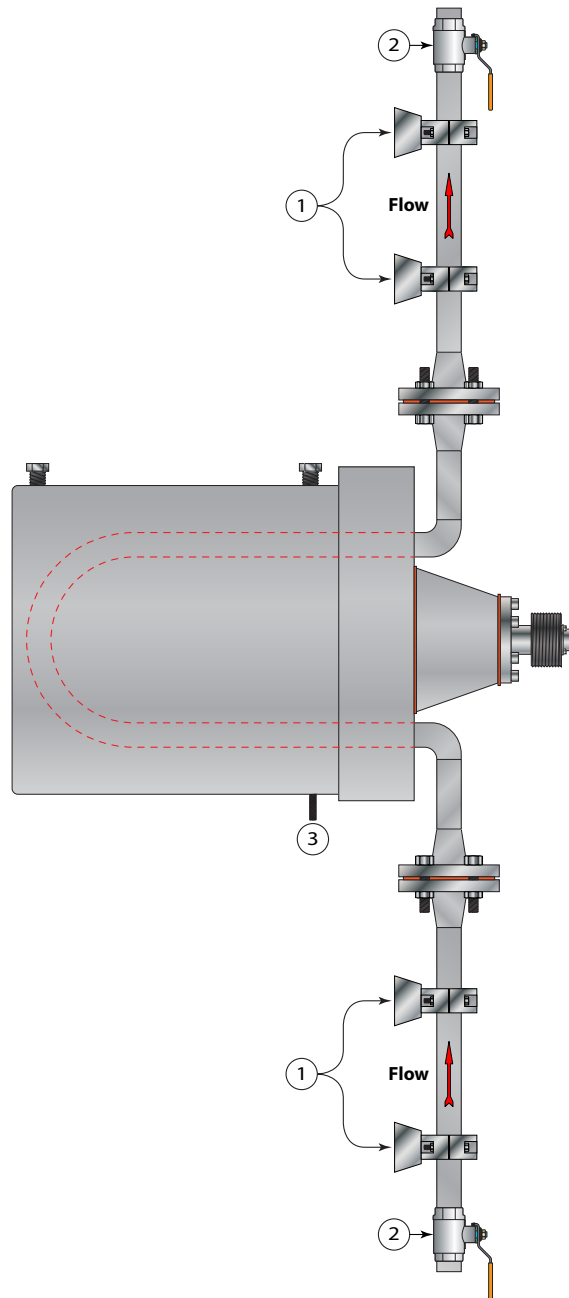

Figure 19: Tubes to the side with flow going up (self-draining)

1	Supports— <b>Customer supplied</b>	Rigid pipe supports approximately 3 and 6 pipe diameters from the end of the sensor
2	Valves— <b>Customer supplied</b>	Full port ball
3	Ground	Protective (earth), 10 AWG (4 mm <sup>2</sup> ) minimum

For self-draining configurations, mount the RCS sensors in vertical pipelines as shown in *Figure 19*.

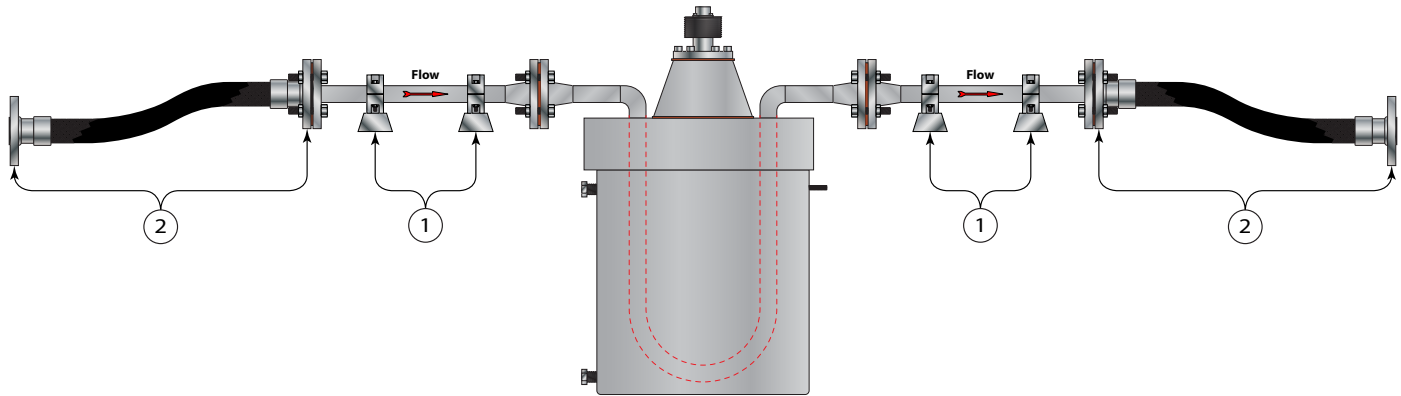

Figure 20: Flexible armored hoses

1	Supports— <b>Customer supplied</b>	Rigid pipe supports approximately 3 and 6 pipe diameters from the end of the sensor
2	Hose— <b>Customer supplied</b>	Flexible armored

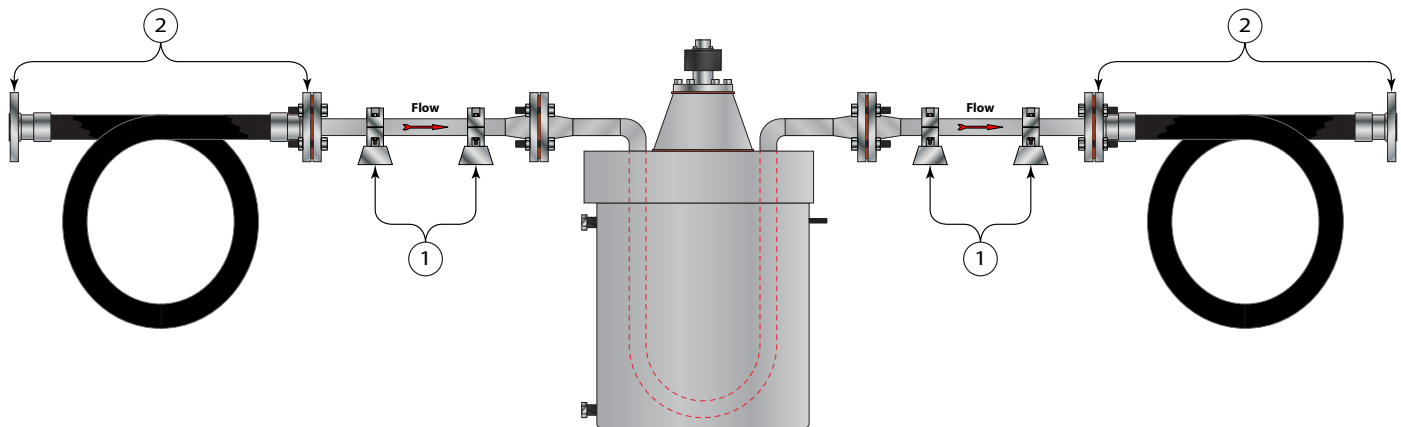

Figure 21: Flexible armored hose loops

1	Supports— <b>Customer supplied</b>	Rigid pipe supports approximately 3 and 6 pipe diameters from the end of the sensor
2	Hose— <b>Customer supplied</b>	Flexible armored

## RCS005 and RCS008 Sensor Installation

The mounting orientation for the RCS005 and RCS008 sensors is identical. The RCS008 is shown below for illustration.

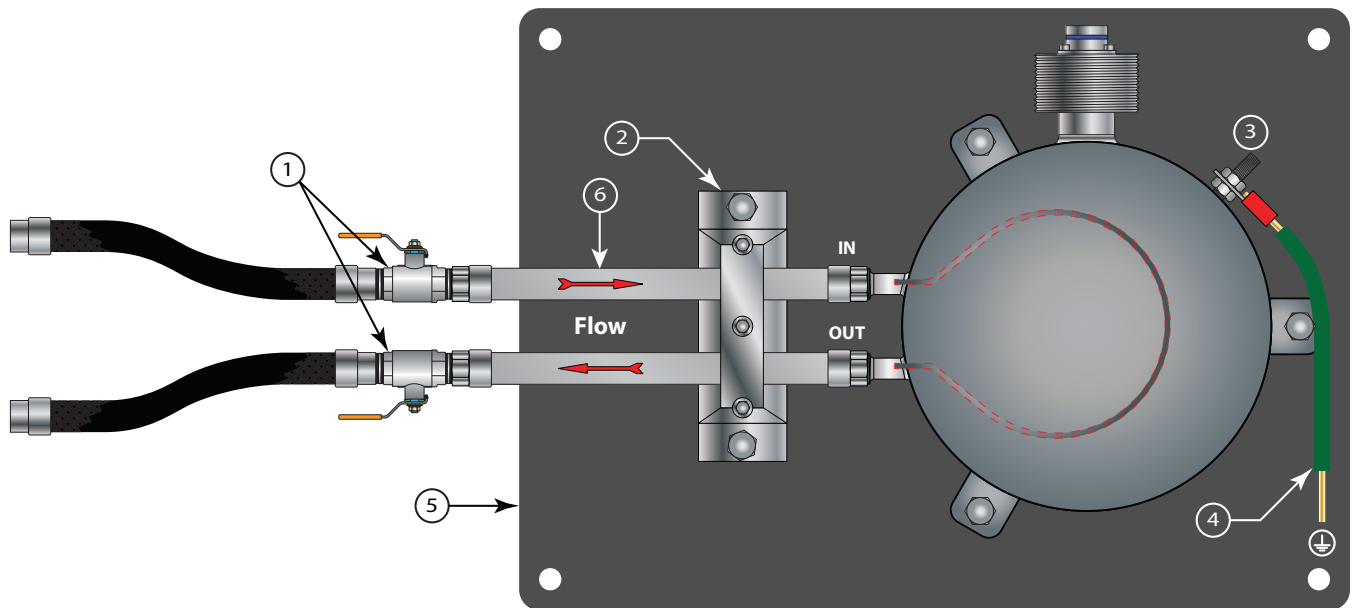

Figure 22: RCS008 mounting

1	Valves— <b>Customer supplied</b>	Full port ball
2	Clamp— <b>Customer supplied</b>	Pipe
3	Screw	Grounding 1/4–20
4	Ground— <b>Customer supplied</b>	Protective (earth), 10 AWG (4 mm <sup>2</sup> ) minimum
5	Plate— <b>Customer supplied</b>	Mounting
6	Pipe or hose— <b>Customer supplied</b>	Mounting

**NOTE:** Vibration isolators are recommended on the mounting feet.

## TRANSMITTER INSTALLATION

### RCTX Transmitters

The RCTX transmitter is either integrated into the sensor or mounted remotely from the sensor. Install the transmitter in an area convenient for observing the LCD readout (RCTX with Display ONLY), programming and servicing.

- Transmitter/Sensor for hazardous locations
- Mount where little vibration exists
- Mount where protected from corrosive fluids
- Transmitter's ambient temperature limits – 4...140° F (–20...60° C)
- Keep out of direct sunlight. Direct sunlight may increase transmitter temperature above maximum temperature
- Allow enough room for maintenance and conduit entrances

### RCTX Transmitters with Integral Mount

**To rotate the orientation of the transmitter relative to the sensor:**

1. Loosen the 1-3/4 in. union hex nut. Be careful to not loosen the feedthrough to the enclosure.
2. Turn the transmitter. Do not turn beyond 180 degrees.
3. When the orientation is correct, tighten the nut to wrench tight.

**To route the power cables:**

Route the power and I/O cables into the transmitter via the explosion-proof conduit holes located on each side of transmitter housing.

RCTX with Display ONLY: Display is designed to be oriented in any 90-degree position based on the orientation of the transmitter/sensor.

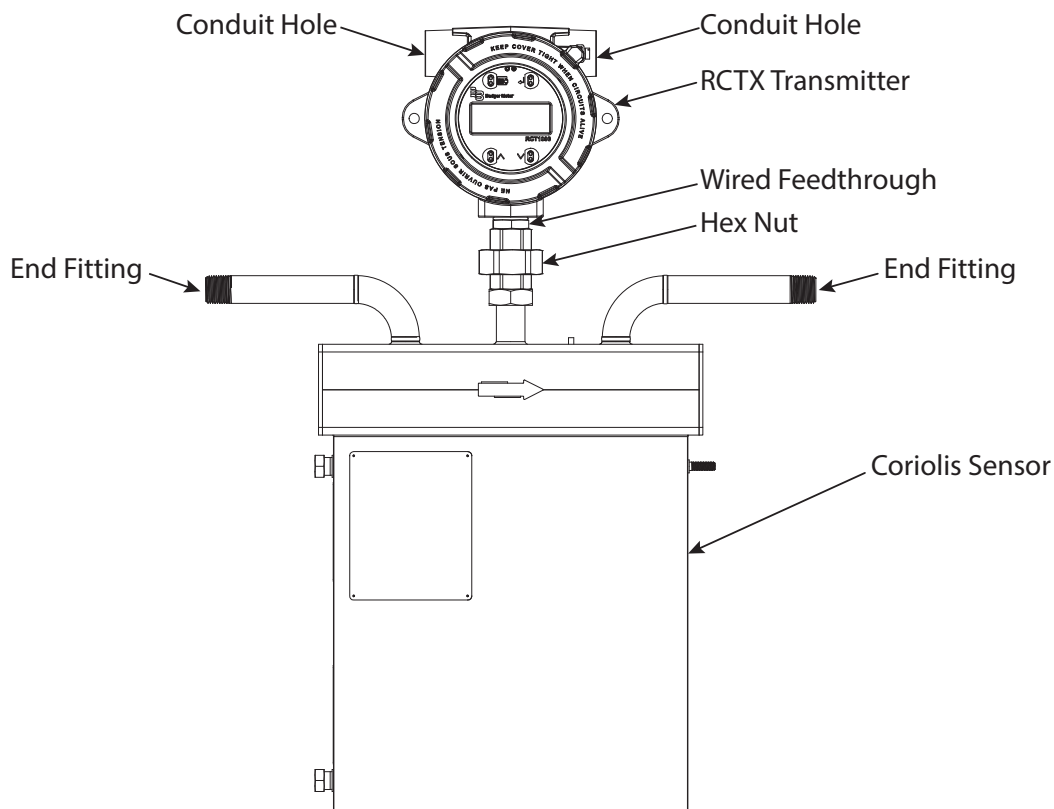

Figure 23: Sensor with integrated RCTX transmitter

**To rotate the orientation of the display board:**

1. Remove power.
2. Remove the cover.
3. Unscrew the four screws holding the display board (hold display board as the last screw is removed so the board does not drop down when mounted vertically).
4. Position the display board and secure with the four screws.
5. Install the cover.

**NOTE:** Use NEMA 4X (IP66) rated fittings/plugs to maintain the watertight integrity of the enclosure.

**RCTX Transmitters with Remote Mount**

To route the power cables:

Route the power and I/O cables into the transmitter via the explosion-proof conduit holes located on each side of transmitter housing.

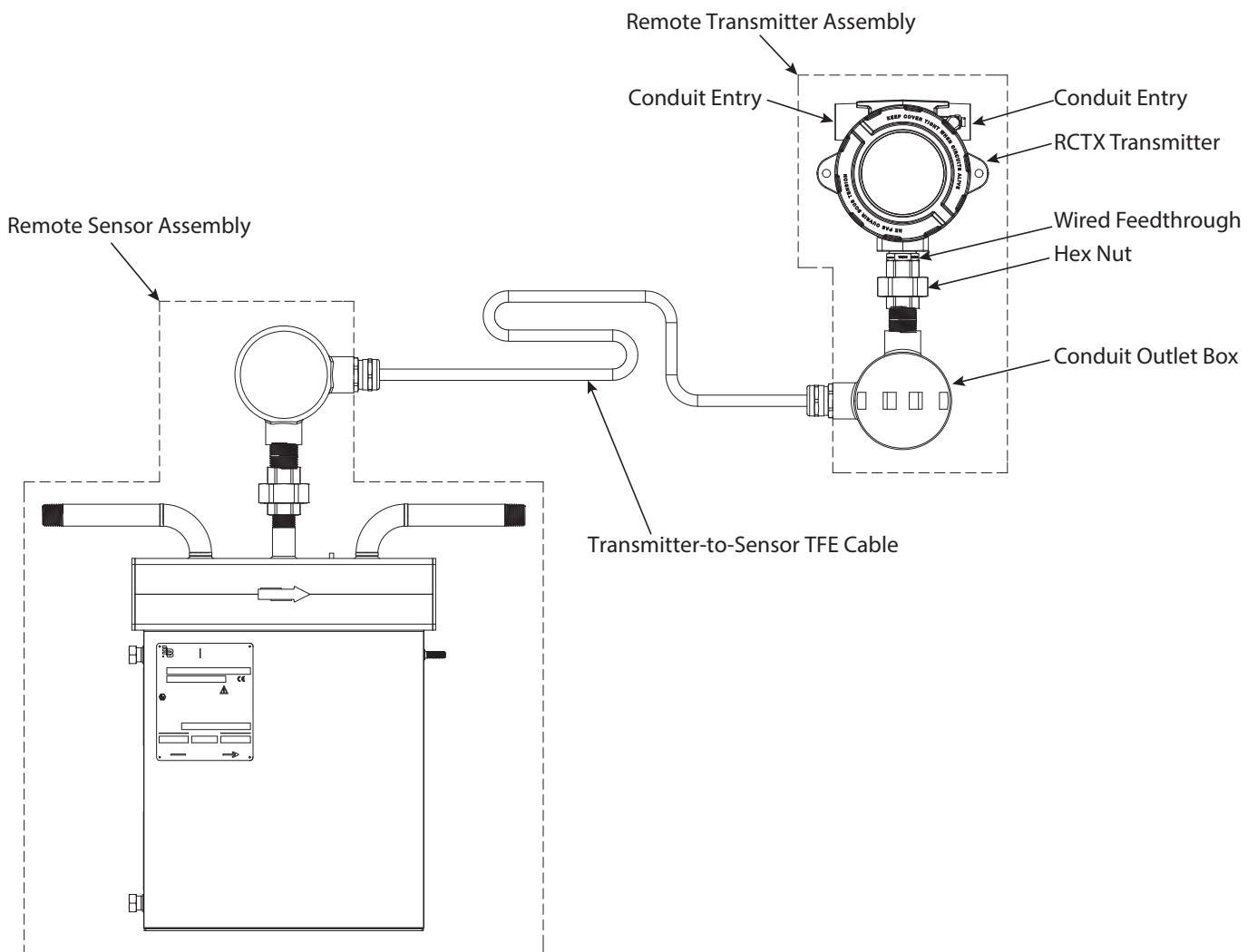

Figure 24: Sensor with remote RCTX transmitter

## RCTN Transmitter

The enclosure should be mounted in an area convenient for observation of the LCD readout, programming and servicing.

1. Locate the transmitter within the length of sensor cable supplied. If this is not possible, the cable should be exchanged for one that is of proper length. In order to increase cable length to an RCS sensor, the cable used must be the same type as used by the manufacturers and must be one continuous piece (no cable splices).
2. Mount the transmitter:
  - In a location known to be non-hazardous
  - Where little vibration exists
  - In an upright position (conduit holes on the bottom) to help avoid fluid ingress
  - Protected from corrosive fluids
  - Within the transmitter's ambient temperature limits – 4...160° F (–10...70° C)
  - Out of direct sunlight. Direct sunlight may increase transmitter temperature above the maximum limit.
3. Make sure enough room is available to allow for door swing, maintenance and conduit entrances. Secure the mounting bracket to a flat surface, 2 in. (50 mm) pipe or frame post with the hardware provided. See *Figure 11 on page 16* and *Figure 13 on page 17* for enclosure and mounting dimension details.
4. Cable should be routed into the transmitter via the conduit holes located at the bottom of the sensor unit. Holes not used for cable entry should be sealed with plugs (RC820428). Optional cable glands (RC820389) are available for inserting sensor and power cables. These parts can be ordered directly from the manufacturer.

**NOTE:** Use NEMA 4 (IP66) rated fittings/plugs to maintain the watertight integrity of the enclosure. Generally, the right conduit hole (viewed from front) is used for power, the left conduit hole for sensor connections, and the center holes for I/O wiring.

## Grounding/Earthing

### IMPORTANT

**All wiring must be suitable for a temperature of at least 203° F (95° C).**

To access terminal blocks for wiring:

- RCTX without display: Remove the cover.
- RCTX with display: Remove the cover and the display board.
- RCTN: Loosen the four screws in the enclosure door and open.

**NOTE:** The sensor cable carries low voltage, high sensitivity signals. Do not add additional length to the cable supplied with the transducers. If additional cable is required, contact the factory to arrange an exchange for a transducer cable with the appropriate length. Cables up to 300 ft (91 meters) are available.

### Earthing Using Rigid Pipe

#### **⚠ WARNING**

**FOR RCTX TRANSMITTERS, USE A POSITIVE GROUNDING RIGID PIPE CONNECTOR. THIS CONNECTOR ACTS AS A PROTECTIVE GROUND AND MUST BE CONNECTED TO AN APPROPRIATE GROUNDING LOCATION.**

#### **⚠ WARNING**

**FOR RCTN TRANSMITTER, THE POWER CONNECTIONS MUST USE THE CONDUIT HOLE ON THE FAR RIGHT AND A POSITIVE GROUNDING RIGID PIPE CONNECTOR. THIS CONNECTOR ACTS AS A PROTECTIVE GROUND AND MUST BE CONNECTED TO AN APPROPRIATE GROUNDING LOCATION.**

## EU Earthing Without Rigid Pipe

### General

All wiring practices should comply to the NEC Article 500 or Canadian Electrical Code (CEC) Part I and Part II or IEC 60079–14 as required by local and/or national codes.

### Connecting or disconnecting devices:

- Make sure the supply voltage is switched off and the transmitter is in a non-hazardous area.
- Use connecting cables rated for a continuous service temperature of  $-10\dots95^{\circ}\text{C}$  ( $T_{\text{amb max}} +20^{\circ}\text{C}$ ).
- Use only certified (conforming to IEC 60079–14 Electrical Installations in Hazardous Areas) cable glands and conduit hole plugs.
- Seal unused entry holes with approved sealing plugs that correspond to the type of protection NEMA 4 or IP66 as required for the installation area. The sealing plugs included with the transmitter meet this requirement and are compliant to both standards.

### Potential equalization (earth bonding)

As a condition of safe use, both an internal and external earth bond are required.

- Internal earth bond is made at the protective earth terminal on terminal block TB101 (for RCTX) or TB1 (for RCTN). Earth bond conductors must be the same gauge or larger than the power supply conductors.
- The external bond is satisfied by connecting the enclosure chassis:
  - ◇ Through hard conduit. See *Figure 27 on page 29* or *Figure 28 on page 30*.  
or
  - ◇ Via armored cable and the use of a cable gland designed to allow a bonding jumper to be run between the gland and protective earth (see *Figure 25*).

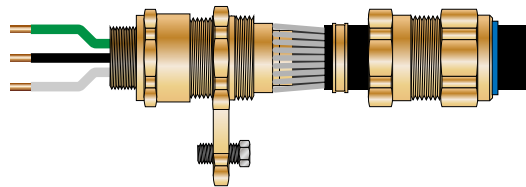

Figure 25: Typical earth bonding connector

## POWER CONNECTIONS

### RCTX DC Power Connections

For wiring details, see the *Coriolis Flow Meters RCTX Control Drawing* document that shipped with this product (also available at [www.badgermeter.com](http://www.badgermeter.com)).

The RCTX operates from a 18...28V DC Class 2 source, as long as the source is capable of supplying a minimum of 7W.

1. Connect an 18...28V DC Class 2 power source as illustrated in the schematic in *Figure 26*. Terminal blocks in the RCTX accommodate wire gauges up to 16 AWG.
2. A switch or circuit breaker is required in the installation.
  - a. The switch or circuit breaker must be in close proximity of the RCTX and within easy reach of the operator.
  - b. The switch or circuit breaker must be marked as the disconnect device for the RCTX.

**NOTE:** DC power input is protected with an internal 1.5 Amp, Slo-Blo, surface mount (non-field serviceable) fuse. This fuse protects only for a catastrophic failure and must be returned to factory for servicing if blown.

**NOTE:** User shall provide external circuit breaker at the source for normal operation.

**NOTE:** RCTX with Display: Must remove display board for terminal block access.

**TB100** (See *Figure 26*.)

- 1 VIN (Power Source 18...28V DC)
- 2 VCOM (Power Source Common)

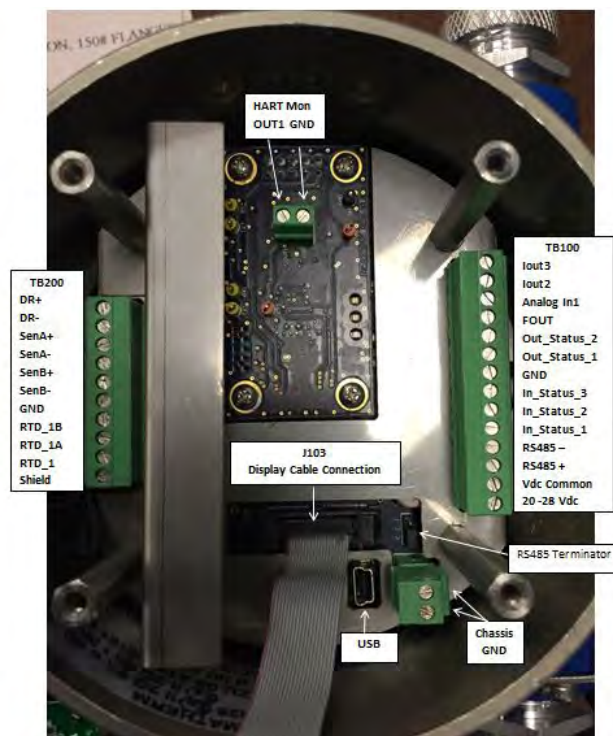

Figure 26: Wiring reference: RCTX with display shown and display board removed for clarity

### RCTN AC Power Connections

1. Verify that switch S1, the AC power selection switch, is set to the appropriate line voltage. The RCTN can be set for either 115V AC or 230V AC. See *Figure 27 on page 29*.
2. The RCTN is shipped with a fuse installed that is designed for 115V service and contains a 0.25 A fuse. If the RCTN is to be operated at 230V AC, replace the fuse in F1 with a 0.125 A slow blow fuse 5 x 20 mm (a 0.125 A fuse is included with the meter).
3. Connect power to the screw terminal block TB1 in the RCT1000 transmitter using the conduit hole on the right side of the enclosure. Connect 115 or 230V AC, AC neutral and protective ground to the TB1 terminals referenced in *Figure 27*. Do not operate without a protective (earth) ground connection. Install using wiring practices that conform to regional, local and national codes. (For example The National Electrical Code Handbook in the U.S.; Canadian Electric (CE) Code in Canada.)



4. See *Figure 27* for AC connection schematic. Terminal blocks in the RCT1000 accommodate wire gauges up to 14 AWG.
5. A switch or circuit breaker is required in the installation.
6. The switch or circuit breaker must be in close proximity of the RCT1000 and within easy reach of the operator.
7. The switch or circuit breaker must be marked as the disconnect device for the RCT1000.

**⚠ WARNING**

- **AS A CONDITION OF SAFE USE, AN EARTH BONDED METAL CONDUIT MUST BE USED ON A MINIMUM OF ONE WIRE ENTRANCE HOLE.**
- **DO NOT OPEN ENCLOSURE WHEN ENERGIZED.**
- **DO NOT REMOVE OR REPLACE FUSE WHEN ENERGIZED.**

**⚠ CAUTION**

**ANY OTHER WIRING METHOD MAY BE UNSAFE OR CAUSE IMPROPER OPERATION OF THE INSTRUMENT.**

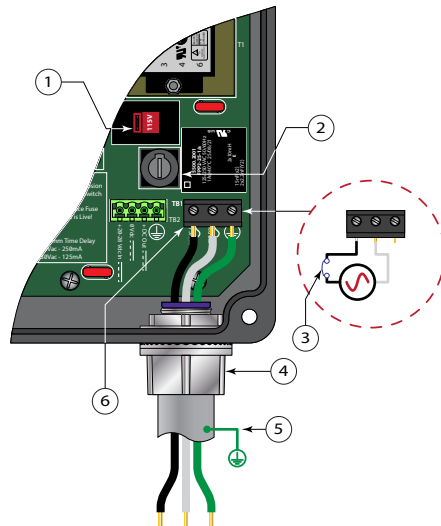

Figure 27: NEMA 4 AC power connections

1	Switch	S1-AC Power selection	4	Connector	Grounding
2	Fuse	F1-For 115V AC input use 0.250 A	5	Ground	External
		F1-For 230V AC input use 0.125 A			
3	Disconnect	Switch or circuit breaker	6	Terminal block	TB1-AC Power connections

**NOTE:** This instrument requires clean electrical line power. Do not operate this unit on circuits with electrically noisy components such as fluorescent lights, relays, compressors or variable frequency drives and similar devices. Do not use a step down transformer from high voltage, high amperage sources. Do not run signal wires with line power conductors within the same wiring tray or conduit.

**RCTN DC Power Connections**

The RCT1000 operates from a 18...28V DC Class 2 source, as long as the source is capable of supplying a minimum of 7W.

1. Connect a 18...28V DC Class 2 power source as illustrated in the schematic in *Figure 28*. Terminal blocks in the RCT1000 accommodate wire gauges up to 14 AWG.
2. A switch or circuit breaker is required in the installation.
  - a. The switch or circuit breaker must be in close proximity of the RCTN and within easy reach of the operator.
  - b. The switch or circuit breaker must be marked as the disconnect device for the RCTN.

**NOTE:** DC powered connections are protected by an automatically resetting fuse. This fuse does not require replacement.

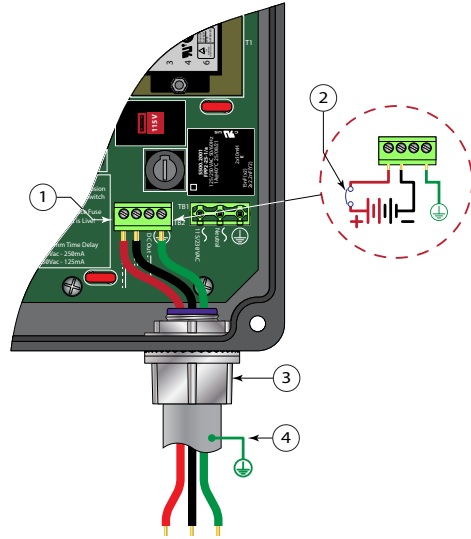

Figure 28: NEMA 4 DC power connections

<b>1</b>	Terminal block	TB2-DC power connections	<b>3</b>	Connector	Grounding
<b>2</b>	Disconnect	Switch or circuit breaker	<b>4</b>	Ground	External

## TRANSMITTER-TO-SENSOR CONNECTIONS

### RCTX-to-Sensor Connections

Integral RCTX transmitters are prewired to the sensor at the factory (no wiring required).

Remotely mounted RCTX transmitters must be wired to the sensor during installation. The sensor wiring in the main transmitter enclosure is prewired. To open the contact on the terminal block, insert a small tool or screwdriver and slide toward the wire opening.

**NOTE:** The black wire with the ring connector terminates at the transmitter. The thicker white wire terminates at the sensor.

### RCTN-to-Sensor Connections

1. Plug the cable connector into the sensor, then rotate the connectors locking ring clockwise until it seats.
2. Slide the protective cable cover over the sensor connections and thread the cover hand tight. See *Figure 29*.
3. Tighten the cable grip tight enough to hold the sensor cable firmly.
4. Route the sensor cable back to the transmitter avoiding spurious signal producing sources.
5. Insert the sensor cable through the weather resistant connector.
6. Guide the sensor cable and weather resistant connector through the transmitter conduit hole located in the bottom left of the RCTN enclosure.
7. Secure the weather resistant connector with hardware supplied.
8. Remove any protective covers from the interface board.
9. Unplug the ten-pin connector on the interface board and attach the sensor cable to the appropriate wire color codes. See *Figure 32*.
10. If an external PT100 RTD is used, connect the RTD to the three-pin plug adjacent to the Coriolis sensor plug.
11. Replace any protective covers and close the enclosure.
12. All RCS sensors are equipped with a 1/4 in. threaded ground stud. Connect this stud to a protective (earth) ground with a minimum of a 10 AWG conductor. See *Figure 22 on page 23* and *Figure 32 on page 33*.

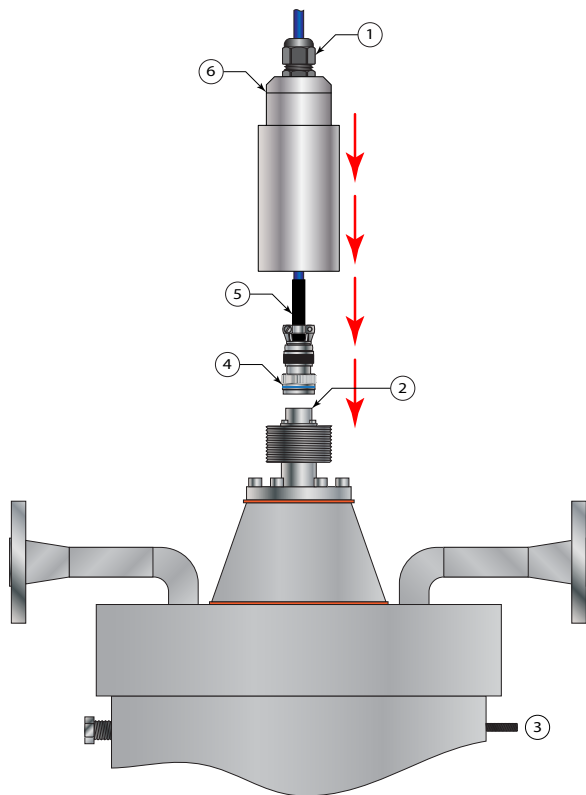

Figure 29: Protective cable cover installation

1	Grip	Cable
2	Connection	Sensor (male)
3	Ground	Protective (earth), 10 AWG (4 mm <sup>2</sup> ) minimum
4	Connection	Cable (female)
5	Cable	Interconnect
6	Cover	Cable (protective)

### Conduit Outlet Box for Remote Mount

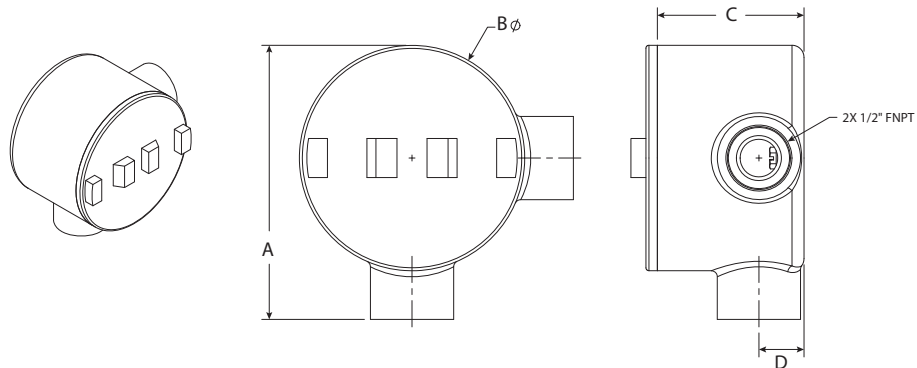

Figure 31: Conduit outlet box for remote mount

A	4.5 in. (116 mm)
B	3.75 in. (95 mm)
C	2.4 in. (62 mm)
D	0.75 in. (19 mm)

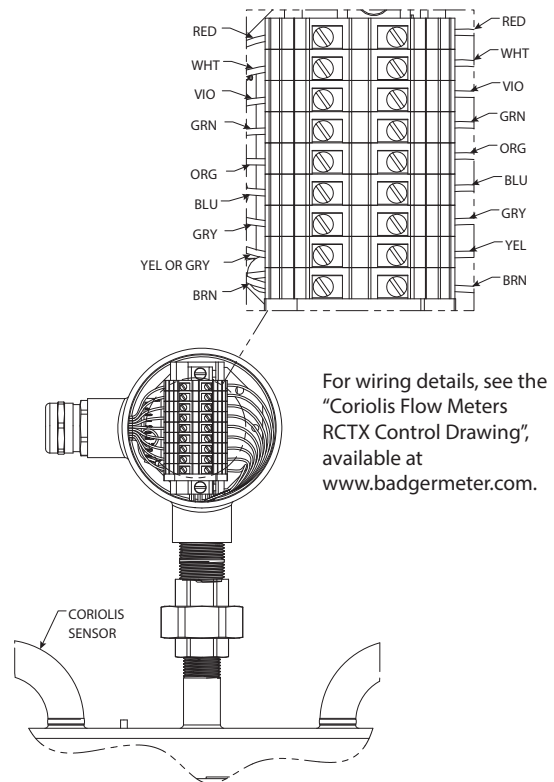

Figure 30: Conduit outlet wiring

RCTN for General Safety Areas

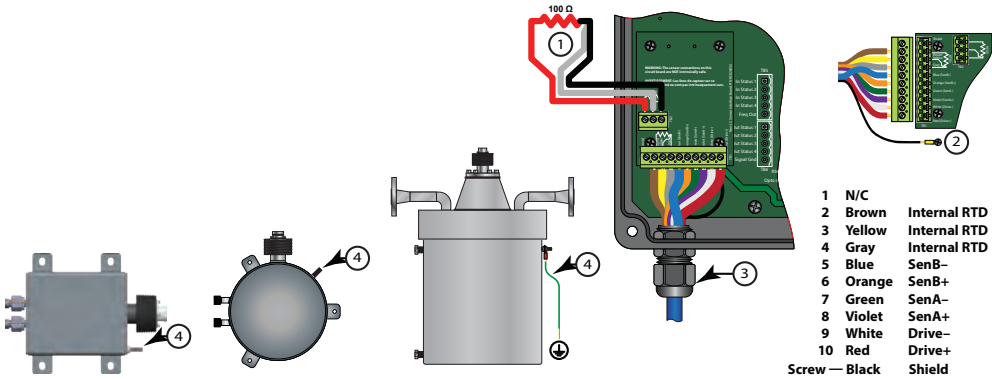

Figure 32: RCTN sensor connections

<b>1</b>	RTD	100 Ω RTD number 2 (optional)	<b>3</b>	Connector	Weather resistant
<b>2</b>	Ground	Shield wire connected to case*	<b>4</b>	Ground	Protective (earth), 10 AWG (4 mm <sup>2</sup> ) minimum

\*With the transmitter oriented as shown in Figure 20, the correct landing for the shield wire is the screw located on the furthest bottom left area of the main board, closest to the sensor wire entry point of the transmitter.

## INPUTS / OUTPUTS

### RCTX Transmitters

**NOTE:** The *lout1* (HART Option), *lout2*, and *lout3* designations can represent any parameters. Units of measure are (appropriately) different.

The transmitter powers the current loop. Applying power from any other external device or load will result in damage to the transmitter.

The frequency/pulse output signal is available as open drain (100 mA sinking max.). This channel is user-selected to operate as a straight frequency output, a pulse output or a PWM output suitable for totalizing.

The two digital output signals are available as open drain (100 mA sinking max.). Each open drain output requires a pullup resistor to DC voltage of 5...28V DC to form a positive voltage pulse. Make this connection in the users' equipment, since the preferred voltage should be available there.

The three digital inputs (DC voltage of 5...28V DC) are used to initiate many of the transmitter's advanced functions.

The analog input (0...5V maximum) is used to form a ratio between the analog input and an analog signal from other devices.

### RCTX TB100 Interface

Terminal	Signal Name	Dir	Signal Description
1	18-28Vdc	In	18...28V DC, 15W max.
2	Vdc Common	In	Power Source Common <b>NOTE:</b> This is NOT same signal as GND. This signal is isolated by an internal common mode filter choke from GND
3	RS485+	I/O	RS485+ Communications (Diff Pair)
4	RS485-	I/O	RS485- Communications (Diff Pair)
5	In_Status_1	In	Digital Input (Low: 0V DC, Active High: 5...28V DC)
6	In_Status_2	In	Digital Input (Low: 0V DC, Active High: 5...28V DC)
7	In_Status_3	In	Digital Input (Low: 0V DC, Active High: 5...28V DC)
8	GND	—	Signal GND (GND for all signals with the exception of power in)
9	Out_Status_1	Out	Digital Open Drain Output. Requires an external pullup resistor to 5...28V DC max. to provide a positive voltage level (100 mA max. sink current)
10	Out_Status_2	Out	Digital Open Drain Output. Requires an external pullup resistor to 5...28V DC max. to provide a positive voltage level (100 mA max. sink current)
11	FOUT	Out	Digital Open Drain Output. Requires an external pullup resistor to 5...28V DC max. to provide a positive voltage level. (10k Hz max. frequency)
12	Analog In1	In	Analog Input, 0...5V max.
13	lout2	Out	Analog Output, 4...20mA (500 Ohm load max.)
14	lout3	Out	Analog Output, 4...20mA (500 Ohm load max.)

### HART Module TB1 Interface

Terminal	Signal Name	Dir	Signal Description
1	lout1	Out	Analog Output, 4...20mA (500 Ohm load max.)/HART communications
2	GND	—	Signal GND (GND for all signals with the exception of power in)

### RCTX TB101 Interface

Terminal	Signal Name	Dir	Signal Description
1	CHASSIS GND	—	Electrical conductivity via internal standoff to RCTX enclosure. Termination for cable shields
2	CHASSIS GND	—	Electrical conductivity via internal standoff to RCTX enclosure. Termination for cable shields

**RCTX Interface Diagrams**

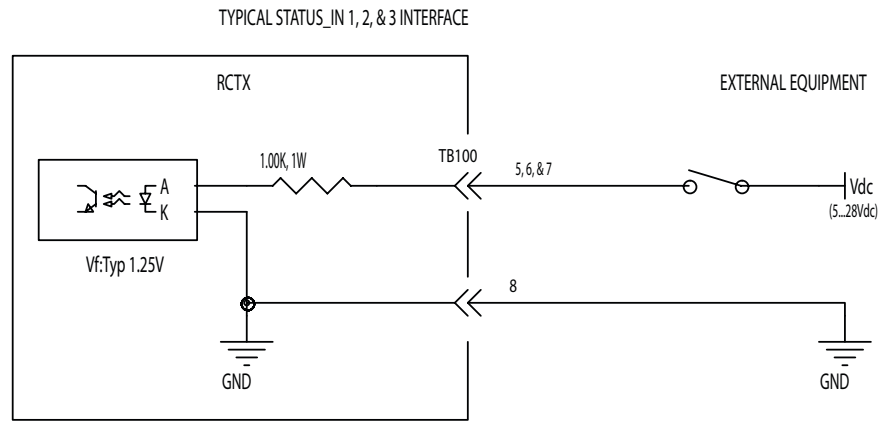

Figure 33: Typical status\_in 1, 2 and 3 interface

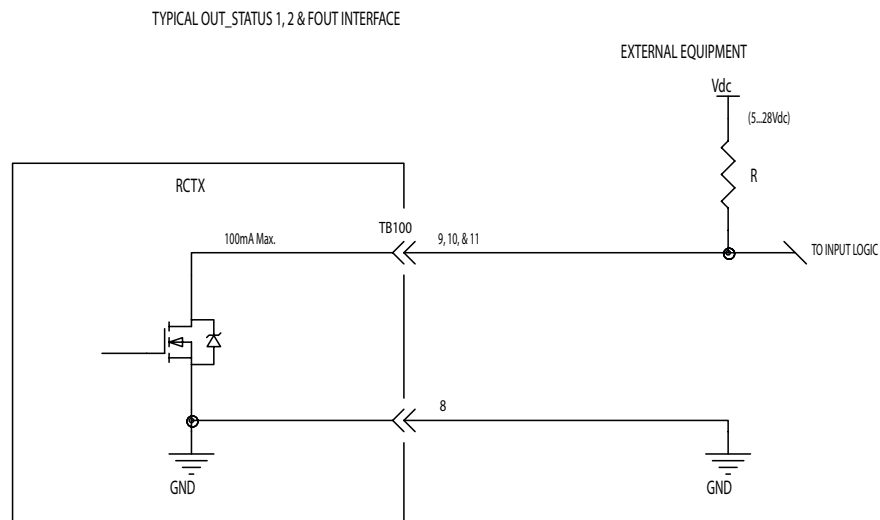

Figure 34: Typical status\_out 1, 2 and fout interface

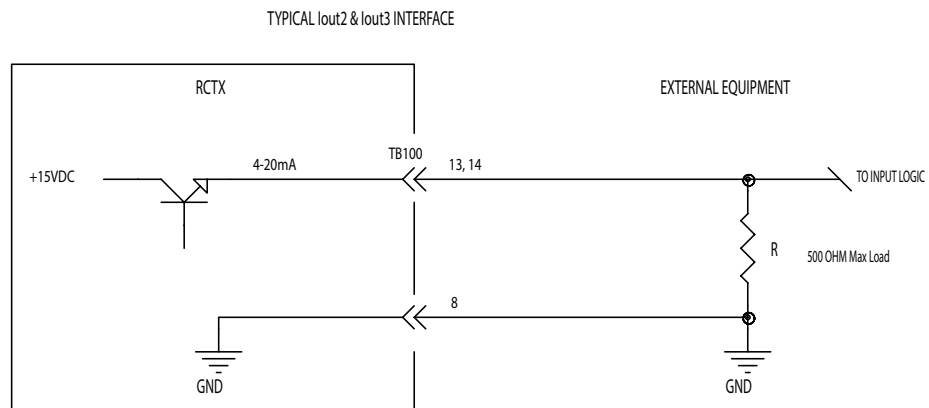

Figure 35: Typical iout2 and iout3 interface

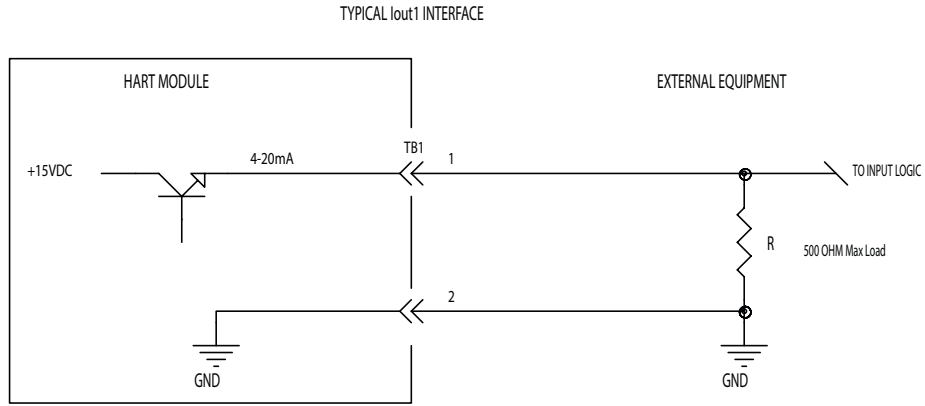

Figure 36: Typical IOUT1 interface

### Replacing the Covers

Turn the covers clockwise and hand-tighten.



Figure 37: RCTX

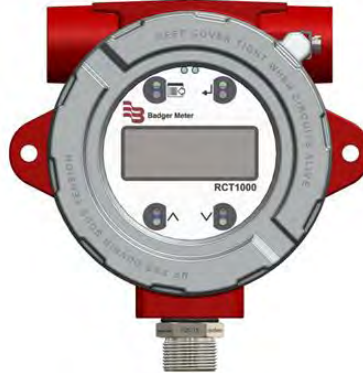

Figure 38: RCTX with display



## RCTN Transmitters

The RCTN has three analog outputs available to send signals to peripheral devices (such as loop-powered remote indicators, controllers and similar equipment). Using the keypad or the RCT Console software for any range between 0...22 mA, the user may independently set these outputs. The default is 4...20 mA. The maximum load (loop) impedance for each output is 500  $\Omega$ .

Normally the lout1 output is set for mass flow. However, this output can represent other parameters. In these cases, the units of measure are (appropriately) different.

**NOTE:** The transmitter powers the current loop. Applying power from any other external device or load will result in damage to the transmitter.

The frequency/pulse output signal is available as an open collector. This channel is user selected to operate as either a straight frequency output, a pulse output or a PWM output suitable for totalizing.

**NOTE:** The maximum current-sinking capacity of the outputs is 100 mA.

**NOTE:** The open collector output requires a DC voltage of 5...28V DC and a pullup resistor to form a positive voltage pulse. It is preferable to make this connection in the users' equipment since the preferred voltage should be available there.

Outputs	Qty	Labeled	Use
4-20 mA	3	lout1 lout2 lout3	The current output reports the configured process variable. The current output parameters control how the process variable reports. Sends signals to peripheral devices such as loop-powered remote indicators, controllers and similar equipment.
Frequency	1	Freq Out	The frequency output can be configured for frequency, pulse or PWM and reports a process variable to counters or totalizers.
Status	4	Out Status 1 Out Status 2 Out Status 3 Out Status 4	An output status event is used to provide notification of process changes and, optionally, to perform specific transmitter actions if the event occurs. An output status event occurs if the real-time value of a user-specified process variable moves above a high setpoint or below a low setpoint. Output status events can also be programmed to occur when a process is within a user-defined range or out of a user-defined range with respect to two user-defined setpoints.
DC Out	1	+DC Out	Unregulated DC supply that can be used to internally power frequency out and status I/O outputs.
Inputs	Qty	Labeled	Use
Status	4	In Status 1 In Status 2 In Status 3 In Status 4	Status inputs are digital signals used to initiate many of the transmitters advanced functions.
Analog In	2	Analog In Analog In 2	Used to form ratio between the analog input and an analog signal from other devices such as flow, temperature, density, pressure and others.

Table 1: RCTN input/output listing

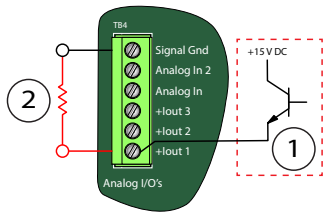

Figure 39: 4 –20 mA current output

1		Representation of internal I/O circuit
2	Load	500 Ω maximum

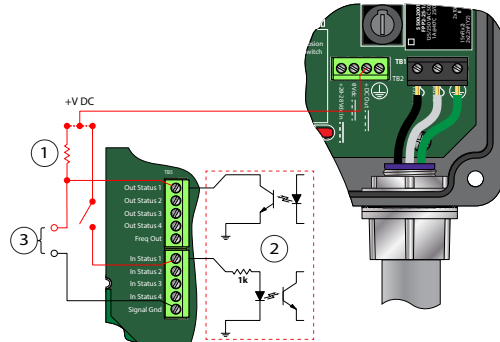

Figure 40: Status inputs and outputs internally powered

1	Resistor	Pullup
2		Representation of internal I/O circuit
3	External device	PLC, pulse counter or other compatible inputs

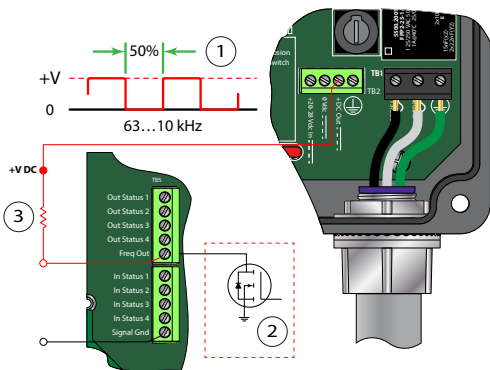

Figure 41: Frequency output internally powered

1	Output representation	50% duty cycle, 63...10k Hz maximum frequency
2		Representation of internal I/O circuit
3	Load	External frequency input device

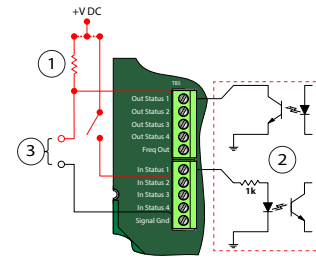

Figure 42: Status inputs and outputs externally powered

1	Resistor	Pullup
2		Representation of internal I/O circuit
3	External device	PLC, pulse counter or other compatible inputs

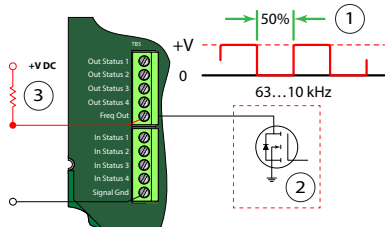

Figure 43: Frequency output externally powered

1	Output representation	50% duty cycle, 63...10k Hz maximum frequency
2		Representation of internal I/O circuit
3	Load	External frequency input device

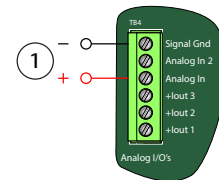

Figure 44: 0...5 Volt input

1	Input	0...5V DC
---	-------	-----------

To preserve environmental sealing of the RCTN, a specific fastener tightening pattern and torque setting is required. Tighten the captive fasteners to a torque setting of 20 in-lb. Follow the pattern in *Figure 45*.

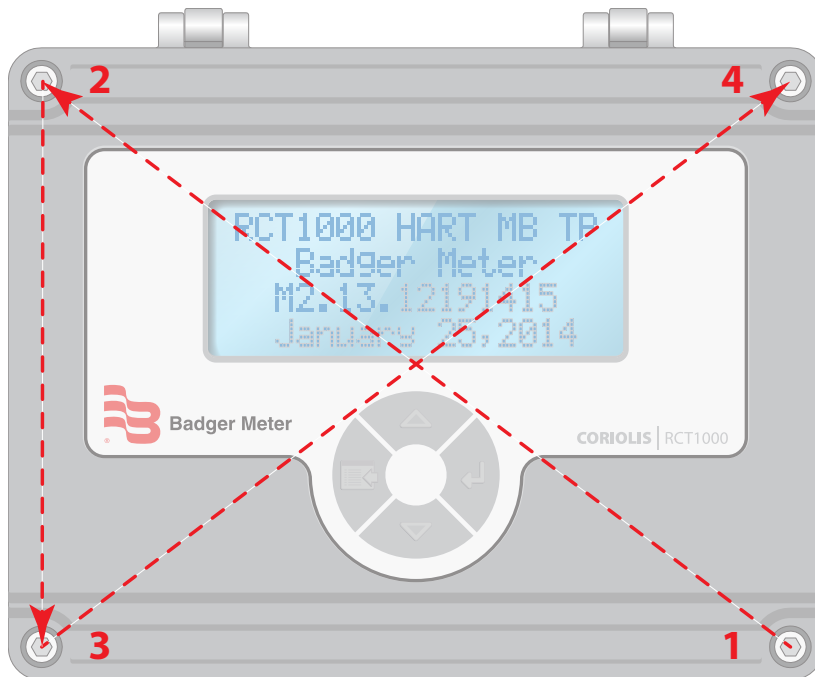
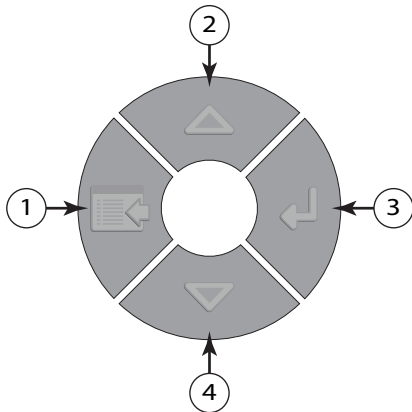

Figure 45: Fastener tightening pattern

## BASIC OPERATION

### Using the Keypad

The buttons are used individually to execute a command or effect a change, according to the mode of the firmware. Button presses are time sensitive. The firmware recognizes two button press durations known as *Press* and *Long Press*. A *Press* lasts for less than two seconds. A *Long Press* lasts longer than two seconds.



1	Button	Menu/Exit
2	Button	Up arrow
3	Button	Enter
4	Button	Down arrow

Figure 46: RCT1000 with RCS005...300 Sensors keypad

### Conventions

Button Name	Button Icon	Functions
Menu/Exit		Shows the menu system from the <i>Home</i> screen. If the user is in the menu system, Menu/Exit returns to the parent menu of the displayed menu/parameter. During editing, a Long Press cancels the editing without any value change. During editing, a short Press changes the value to zero. If <i>WARNING</i> is shown in 4 <sup>th</sup> line, then a short Press shows the <i>WARNINGS</i> screen. If <i>WARNING</i> is shown in 4 <sup>th</sup> line, then a Long Press returns the user to the parent screen or allows the user to enter the menu system from the <i>Home</i> screen.
Up Arrow		In parameter value editing mode, a Long Press moves the cursor one position to the right and a short Press changes a character. In menus and parameter lists, a short Press moves a menu or parameter list up.
Down Arrow		In parameter value editing mode, a Long Press moves the cursor one position to the left and a short Press changes a character. In menus and parameter lists, a short Press moves a menu or parameter list down.
Enter		If a menu item is shown in the active line, then a short Press enters into that menu. If a parameter is shown in the active line, then a Long Press starts parameter value editing mode if the parameter's access rights and the set password allow it. If a parameter is edited, then a Long Press closes the parameter editor and saves any new change.

Table 2: Keyboard icons

**NOTE:** The optical buttons on the hazardous location RCTX transmitter may be locked to prevent accidental activation of the buttons. To unlock, press the **Up** arrow, **Down** arrow, **Menu/Exit** and **Enter** buttons sequentially. The Lockout function can be enabled or disabled through parameter KbLock (303).

If the optical buttons are not working properly, check that the windowed cover is fully tightened. The buttons will not activate if the window is too far away.

## The Active Line

The RCT1000 uses the concept of the Active line to make changes to the transmitter's instructions. The active line is the topmost line on the display and whatever parameter or menu is on the active line can be edited or stepped into.

**NOTE:** The active line is only used in editing mode or menu navigation.

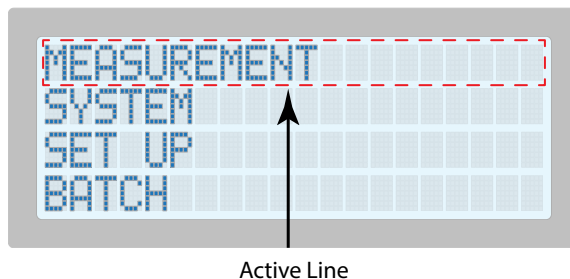





















Figure 47: The active line









## Button Functions Based on Location In Menus





Keypad Functions from the Home Screen (Without Warnings)			
Button	Press Duration	Function	Notes
	Press	Steps into the top level menu screen.	
	Long Press		
	Press	Scrolls the user defined parameters upward.	
	Long Press		
	Press	Scrolls the user defined parameters downward.	
	Long Press		
	Press	Performs no action.	
	Long Press	Edits parameter in active line assuming password access allows it.	
Keypad Functions from the Home Screen (With Warnings)			
Button	Press Duration	Function	Notes
	Press	Shows the warnings screen.	
	Long Press	Steps into the top level menu system.	
	Press	Scrolls the user defined parameters upward.	If not within warning screen.
	Long Press		
	Press	Scrolls the user defined parameters downward.	If not within warning screen.
	Long Press		
	Press	Performs no action.	
	Long Press	Edits parameter in active line assuming password access allows it.	





Keypad Functions from the Top Level Main Menu Screen (Without Warnings)			
Button	Press Duration	Function	Notes
	Press	Returns user to <i>Home</i> screen.	
	Long Press		
	Press	Scrolls the list of available menus upward.	
	Long Press		
	Press	Scrolls the list of available menus downward.	
	Long Press		
	Press	Steps into the menu shown on the active line.	
	Long Press		

Keypad Functions from the Top Level Main Menu Screen (With Warnings)			
Button	Press Duration	Function	Notes
	Press	Shows the warning screen.	
	Long Press	Returns the user to the home screen.	
	Press	Scrolls the list of available menus upward.	If not within warning screen.
	Long Press		
	Press	Scrolls the list of available menus downward.	If not within warning screen.
	Long Press		
	Press	Steps into the menu shown on the active line.	
	Long Press		

Keypad Functions from Submenus (Without Warnings)			
Button	Press Duration	Function	Notes
	Press	Returns user to the parent menu.	
	Long Press		
	Press	Scrolls the list of available submenus upward.	
	Long Press		
	Press	Scrolls the list of available submenus downward.	
	Long Press		
	Press	Steps into the menu shown on the active line.	
	Long Press		





<b>Keypad Functions from Submenus (With Warnings)</b>			
<b>Button</b>	<b>Press Duration</b>	<b>Function</b>	<b>Notes</b>
	Press	Shows the warning screen.	
	Long Press	Returns user to the parent menu.	
	Press	Scrolls the user defined submenus upward.	If not within warning screen.
	Long Press		
	Press	Scrolls the user defined submenus downward.	If not within warning screen.
	Long Press		
	Press	Steps into the menu shown on the active line.	
	Long Press		
<b>Keypad Functions from the Parameter Screens (Without Warnings)</b>			
<b>Button</b>	<b>Press Duration</b>	<b>Function</b>	<b>Notes</b>
	Press	Returns user to the parent menu.	
	Long Press		
	Press	Scrolls the parameter list upward.	
	Long Press		
	Press	Scrolls the parameter list downward.	
	Long Press		
	Press	Performs no action.	
	Long Press	Initiates the editing function for the parameter in the active line.	





Keypad Functions from the Parameter Screens (With Warnings)			
Button	Press Duration	Function	Notes
	Press	Shows the warning screen.	
	Long Press	Returns user to the parent menu.	
	Press	Scrolls the parameters list upward.	If not within warning screen.
	Long Press		
	Press	Scrolls the parameters list downward.	If not within warning screen.
	Long Press		
	Press	Performs no action.	
	Long Press	Initiates the editing function for the parameter in the active line.	





Keypad Functions from the Parameter Edit Screens (Without Warnings)			
Button	Press Duration	Function	Notes
	Press	Clears the edited value to +0.	
	Long Press	Cancels edit(s) and returns to the parameter screen.	
	Press	<b>Values:</b> Increment. <b>Resolution:</b> Increment. <b>Units:</b> Scrolls available list upward.	
	Long Press	Moves the cursor to the right if the value is being edited.	
	Press	<b>Values:</b> Decrement. <b>Resolution:</b> Decrement. <b>Units:</b> Scrolls available list downward.	
	Long Press	Moves the cursor to the left if the value is being edited.	
	Press	Cycles through editing areas (value, resolution and units).	Does nothing for list type parameters.
	Long Press	Saves any changes and returns user to the parent parameter screen.	

Keypad Functions from the Parameter Edit Screens (With Warnings)			
Warnings cannot be handled when in editing mode.			



Keypad Functions from the Parameter Edit Screens (List Type) (Without Warnings)			
Button	Press Duration	Function	Notes
	Press	Reverts to the first selection on the list.	
	Long Press	Cancels edit(s) and returns to the parameter screen.	
	Press	Scrolls the list options upward.	
	Long Press		
	Press	Scrolls the list options downward.	
	Long Press		
	Press	Performs no action.	
	Long Press	Saves any changes and returns user to the parent parameter screen.	

Keypad Functions from Warning Screen			
Button	Press Duration	Function	
	Press	Returns to the screen from which the warning screen was called.	
	Long Press	Clears all warnings and returns to the screen from which the warning screen was called.	
	Press	Scrolls the list of available warnings upward.	
	Long Press		
	Press	Scrolls the list of available warnings downward.	
	Long Press		
	Press	Displays the timestamp of warning in the active line at the time and date of occurrence.	
	Long Press		

Keypad Functions from Warning Details Screen			
Button	Press Duration	Function	
	Press	Returns to the warning screen.	
	Long Press	Clears the individual warning and returns to the warning screen.	
	Press	Performs no action.	
	Long Press		
	Press	Performs no action.	
	Long Press		
	Press	Performs no action.	
	Long Press		

**NOTE:** Some displays, calibrations and setup parameters are password protected. The proper password level must be used to gain access to password protected parameters.

## FINAL CHECKS

1. Confirm the flow sensor has been installed correctly.
2. Confirm the transmitter has been installed correctly.
3. Confirm all transmitter connections have been made correctly to the sensor.
4. Confirm the *Flow Factor* and *Density* calibration constants are the same on both the serial tags and calibration documents. See "Sensor Check" on page 49 for more information.
5. Familiarize yourself with the basic operation of the transmitter keypad.
6. Power up the transmitter. The display reads the current firmware version and does a self test.
7. Fill the flow sensor with fluid, passing the fluid through for at least ten minutes at a flow rate greater than twenty percent of the rated capacity of the meter.
8. Perform a zero calibration, see "Initial Zeroing Procedure" on page 50.

### Startup Screens

**NOTE:** Screens may differ depending on firmware version and enabled options.

1. Example of startup splash screen.



Figure 48: Splash screen

2. The transmitter is looking to see if there is a sensor connected. The Initializing text will display for one minute if no sensor is connected.

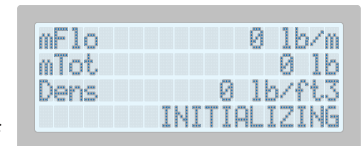

Figure 49: Transmitter initializing

3. If there is a sensor connected, the screen should look similar to this, if there is no flow and the meter is full of fluid.

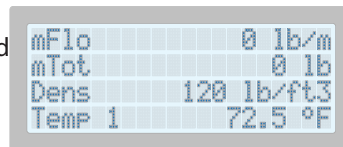

Figure 50: Sensor connected—no flow

4. If there is fluid flow, the screen will look similar to this.

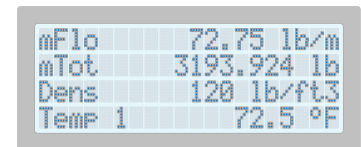

Figure 51: Sensor connected—with flow

5. If there is no sensor connected, the screen will change from *INITIALIZING* to *WARNING*.

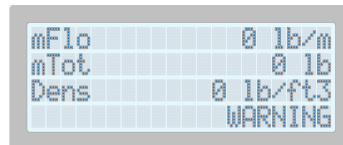

Figure 52: No sensor warning screen

# MENU MAP



Figure 53: Menu map

\*\* Hidden menus. Must be Enabled to view.

## NAVIGATION DURING AN ALARM CONDITION

When any sort of warning occurs, the keypad functionality changes—a momentary press of the **Menu/Back** button brings up the *Warnings* menu. At this time, you may feel you are stuck in a loop toggling back and forth between the Display and an alarm or warning.

To navigate to the Root list of menus, press and hold the **Menu/Back** button to move back in the directory.

This may be required in order to change the scaling of an output channel or to see what may be causing the alarm condition to occur.

Only during alarm or warning conditions will you need to use the long press function on the Menu/Back button to move back up the menu list. See "*Basic Operation*" on page 40 for further details.

## WARNING HELP

Any warning that appears on the transmitter will be erased from the screen once the problem has been fixed.

To clear WARNINGS:

1. Press **Menu** to bring up the *WARNINGS* window, which lists all current alarms and faults in the transmitter.
2. Press the arrow buttons to move the alarm or warning to the active line and press **Enter**.  
The display will prompt more information about the alarm or fault. It will display the time and date of the error.
3. To clear the warning, press and hold **Menu**. The screen will return to the menu related to the error.

**NOTE:** If the error is still present, the WARNING message will come back.

## SYSTEM PASSWORDS

1. From the *Home* screen press **Menu** to enter the top level menus.
2. Use **Up** or **Down** to scroll until *SETUP* is in the active line of the display then press **Enter**.
3. From the *SETUP* prompt, press **Up** or **Down** until the display shows *Password*.

**NOTE:** In this menu, there are two parameters. *PWLvl* indicates the password level entered, if any. *PWSet* is the parameter used to change the password level.

4. To change to another password level, use **Up** or **Down** until *PWSet* is in the active line of the display, then press and hold **Enter**.
5. A cursor will appear under the first character of the password.
  - a. Using **Up** or **Down**, increment or decrement the value as needed.
  - b. To move the cursor to the next character space, press and hold **Up** to move the cursor to the right or press and hold **Down** to move the cursor to the left.
  - c. Follow this procedure to enter the required password PIN (personal identification number), then press and hold **Enter** to save the password.

### Default Passwords

The default system passwords PINs (personal identification numbers) are:

Engineer: 525

Technician: 604

Operator: 117

**NOTE:** Each higher password level inherits the capabilities of any passwords below it. To change the password PINs associated with each password level, see "*Changing a Password PIN*" on page 49.

## Changing a Password PIN

In the following instructions, Scroll means to press the **Up** or **Down** button. To change the default password pins for an additional level of security:

1. From the *Home* screen, press **Menu/Exit** to step into the top Main Menu structure.
2. Scroll through the menus until *SETUP* appears in the active line. Press **Enter**.
3. Scroll through the menu list until *PASSWORD* appears in the active line. Press **Enter**.
4. Scroll until parameter *PWSet* is in the active line. Press and hold **Enter** to initiate the editing function.
5. Enter the password pin for Engineer (525). (A short press of **Up** or **Down** changes the indicated character value. A long press of **Up** or **Down** moves the cursor to the right or left, respectively.) Press and hold **Enter** to save the change.
6. Press **Menu/Exit** to leave the *Password* menu, then step back into it. With *PASSWORD* in the active line, press **Enter**.

The available items in the password menu should now be *PWSet*, *PWLvl*, *Pr1*, *Pr2* and *Pr3*.

<b>PWSet</b>	Parameter used for entering password pins
<b>PWLvl</b>	Parameter showing which level of password is currently active in the transmitter
<b>Pr1</b>	Password Pin for Operator: Default (117)
<b>Pr2</b>	Password Pin for Technician: Default (604)
<b>Pr3</b>	Password Pin for Engineer: Default (525)

Table 3: Password menu parameters

To change the default pin associated with a particular password level:

7. Scroll until *Pr1*, *Pr2* or *Pr3* is on the active line, then press and hold **Enter** to begin the editing function.
8. The maximum pin length is 5 characters and can be numbers only. Use short presses of **Up** or **Down** to change the character value. Use long presses of **Up** or **Down** to move the cursor right and left, respectively. Press and hold **Enter** to save the change.

*Pr1*, *Pr2* and *Pr3* only change the pin for a particular password level. To make a particular password level active, you must enter the default or user-assigned pin in the *PWSet* parameter.

**NOTE:** Factory assistance is required to restore user-defined passwords.

## SENSOR CHECK

It is important to check that the sensor and transmitter are correctly matched. Unmatched sensor and transmitter pairs will produce inaccurate readings.

To check that the correct sensor has been connected to the correct transmitter, refer to the calibration documents that are sent with the meter system. The Flow Calibration Report includes vital information pertaining to the specific sensor and transmitter pair. Under "Product Information" there are fields for both sensor and transmitter model number and serial number.

Look at the outside of the sensor and transmitter and locate the serial tags. Pair the transmitter to the appropriate sensor by matching the serial numbers as indicated on the calibration report.

After the transmitter is powered on, make sure the calibration constants entered into the transmitter match the information provided on the serial tags and the calibration documents.

Flow Factor (FloFct): Main Menu > Set Up > Calibration > Flow

DAlpha: Main Menu > Set Up > Calibration > Density

DBeta: Main Menu > Set Up > Calibration > Density

If the numbers entered in the transmitter do not match what was provided on the serial tags and the calibration report, contact the factory for assistance.

## INITIAL ZEROING PROCEDURE

### Priming for Zero

This procedure requires a password level of Operator or higher.

The flow sensor must be completely full at stable process temperature and pressure before zeroing the system.

Even if the flow sensor has already been filled, circulate fluid for a minimum of 10 minutes at a flow rate greater than 20% of the rated full scale value of the flow sensor to purge both the process piping and sensor of air.

**NOTE:** Do not attempt the initial startup procedure with a partially filled sensor.

**NOTE:** If the process temperature or pressure changes significantly, the meter may need to be re-zeroed. If the meter is to be re-zeroed, make sure the meter is completely full and flow is shut off by first closing the downstream blocking valve and then the upstream blocking valve. This ensures there is no potential for cavitation in the sensor. Stopping the pump or relying on check valves does not ensure the zero flow condition necessary to perform the system zero.

### Zeroing the System

**NOTE:** The system must be zeroed after installation and before normal operation.

1. Run flow through the sensor at the highest possible rate for several minutes to eliminate any entrained gases in liquid systems.
2. Stop all flow and close the downstream and upstream blocking valves. Close the downstream valve first to prevent draining of the system.
3. From the *Home* screen, press **Menu** to enter into the Main Menu.
4. Press **Up** or **Down** to scroll through the list until *SETUP* appears in the active line, then press **Enter**.
5. Press **Up** or **Down** to scroll through the list until *CALIBRATION* appears in the active line, then press **Enter**.
6. Press **Up** or **Down** to scroll through the list until *ZERO CALIBRATION* appears in the active line, then press **Enter**.
7. Press **Up** or **Down** to scroll through the list until *START ZERO* appears in the active line.

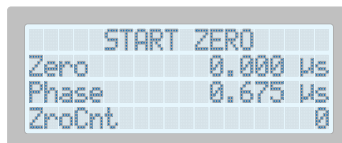

Figure 54: Start zero screen

8. Press and hold **Enter** to initiate a zero calibration.
9. Press **Menu** until the top level menu screen is reached.
10. Press **Up** or **Down** to scroll through the list until *MEASUREMENT* is in the active line, then press **Enter**.
11. Press **Up** or **Down** to find the *mFlo* parameter. It should read all zeros.
12. Return to the *Home* screen. If there is a prompt to back up the transmitter, choose this action. If the prompt to back up the transmitter does not appear prior to getting to the *Home* screen, back up the transmitter manually.
13. Open the blocking valves. The meter is now ready to use.

## HOME SCREEN SETUP

RCT1000 transmitters feature a home screen to allow users to view whichever parameter is required to be in view at all times.

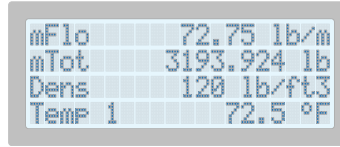

Figure 55: Home screen example

The RCT1000 has a four line display, but the *Home* screen holds eight parameters that are viewable at one time. Using **Up** or **Down**, users can view these parameters as this list scrolls and wraps around.

To set up the parameters for the *Home* screen:

1. From the *Home* screen, press **Menu** to step into the high level menus.
2. Using **Up** or **Down**, scroll through the list until *SETUP* appears in the active line and press **Enter**.
3. Using **Up** or **Down**, scroll until *DISPLAY* appears in the active line and press **Enter**.
4. Using **Up** or **Down**, scroll through the parameter list. Parameters are named *Param1*...*8*. These parameters correlate the order and ID for the parameters to be displayed on the *Home* screen. The parameter under *Param1* will be the default parameter listed on the first line of the *Home* screen, *Param2*...*8* follow suit.

**NOTE:** On the Home screen, use **Up** or **Down** to scroll through the available parameters.

Home screen Line 1	Param1	Home screen Line 5	Param5
Home screen Line 2	Param2	Home screen Line 6	Param6
Home screen Line 3	Param3	Home screen Line 7	Param7
Home screen Line 4	Param4	Home screen Line 8	Param8

Table 4: Home screen parameters

5. To edit which parameters are seen, place the required *Param1*...*8* in the active line and press and hold **Enter**.
6. Using **Up** or **Down**, scroll through the list of available parameters that can be seen on the *Home* screen.
7. Once a required parameter is seen, press and hold **Enter** to save the change. This parameter will now be listed to the line assigned on the *Home* screen.
8. After the required parameters to be viewed have been set, press **Menu** until the *Home* screen is reached.

### Enable/Disable Hidden Menus

1. From the *Home* screen, press **Menu** to enter the top level menus.
2. Using **Up** or **Down**, scroll through the list of available menus until *SETUP* is in the active line and press **Enter**.
3. Using **Up** or **Down**, scroll through the list of available menus until *MENUS* is in the active line and press **Enter**.
4. There are seven additional menus that can be enabled or disabled:
  - MnuBatch* (Batch Controller Menu)
  - MnuPID* (PID Controller Menu)
  - MnuTot* (Totalizer Menu)
  - MnuAlarm* (User Defined Alarm Menu)
  - MnuConc* (Concentration Menu)
  - MnuApp* (Special Application Menu)
  - MnuNet* (Net Flow Menu)
5. To enable or disable one of these menus, use **Up** or **Down** to scroll through the list and place the required menu to be *Enabled* or *Disabled* into the active line of the display.
6. Press and hold **Enter**.
7. Use **Up** or **Down** to scroll through the available options (*Show menu* or *Hide menu*).
8. To show the menu, select *Show menu*, then press and hold **Enter**. To hide the menu, select *Hide menu*, then press and hold **Enter**.

**NOTE:** Enabled/shown menus appear at the top level Main Menu structure.

## HMI EXAMPLES



Figure 56: Example of startup screen

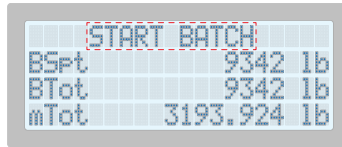

Figure 57: Example of a command

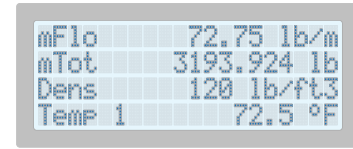

Figure 58: Home screen or base parameter level within a menu

Figure 37 is also an example of parameters where units, resolution and value can be changed, password permitting.

**NOTE:** Measured or calculated values cannot be changed.

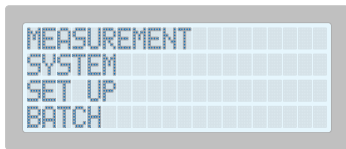

Figure 59: Example of transmitter being in menus or submenus

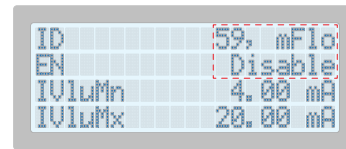

Figure 60: Example of parameters with enumerations

## EDITING PARAMETER UNITS, VALUES AND RESOLUTION

There are two ways to change the units, values and resolution associated with a parameter. It can either be done from the user defined *Home* screen or from stepping into the menus and changing the parameter at the bottom (parameter) level of the menu structure.

To change these items:

1. Scroll **Up** or **Down** until the required parameter is in the active line, then press and hold **Enter**.
2. The default item to be edited first is the value of the unit. Use **Up** or **Down** to change the value of the highlighted character. Press and hold **Up** to move the cursor to the right or press and hold **Down** to move the cursor to the left.
3. After changing the value, press **Enter**.
4. The next item to be edited is the unit of the parameter. Use **Up** or **Down** to scroll through the list of available units. Once the required unit appears, press **Enter**.
5. After step four, the next item to be changed is the resolution. This will appear in a **###** format. Use **Up** to increase the resolution or **Down** to decrease the resolution. The number of pound signs after the decimal indicates the resolution that will be set.
6. Press and hold **Enter** to save changes made to the parameter.

**NOTE:** Bypass any of the three edits by pressing **Enter**. The parameter will not save until you press and hold **Enter**.

**NOTE:** Not all parameters have values, resolutions or units associated with them. If an item is not available for the parameter, the item will not appear.

**NOTE:** Parameters with lists and no measured or calculated value with units, values and resolutions associated with them, still follow the same format for editing. Once the parameter is in edit mode, the list will appear and the user can scroll through the available list for the parameter. After the required one appears, press and hold **Enter** to save the parameter with the list item selected.



## BACKING UP THE TRANSMITTER

There are three ways to create backups:

- Automatically through flagged parameters.
- Manually through the HMI
- Through the RCT Console software

### Automatic Backup

The automatic backup feature prompts you to initiate a backup. There are certain parameters within the transmitter that are flagged to create a backup if they are changed. These are parameters that have a significant impact on the configuration, whether it is a meter zero or a density factor. For a list of these parameters, see *"Backup Enabled Parameters" on page 54*.

Any time one of these is changed, it will signal the transmitter of the change. Once the user steps back out to the *Home* screen, prior to entering the *Home* screen, a prompt like this will appear. Follow the on-screen commands to either create or cancel the backup.



Figure 61: Parameter change triggered backup

### Manual Backup

To create backups manually through the HMI:

1. From the *Home* screen, press **Menu** to enter the top level Main Menu.
2. Using **Up**, **Down** and **Enter**, navigate to the *SETUP > CALIBRATION > PRIMARY* menu.
3. Scroll **Up** or **Down** through the list of available parameters and place *BackUp* on the active line.
4. Press and hold **Enter** to bring the parameter into editing mode.
5. When in editing mode, a cursor will appear under the enumeration text shown to the right of the parameter name. Use **Up** or **Down** to switch the entry from *Idle* to *Backup* (see *Figure 62*).

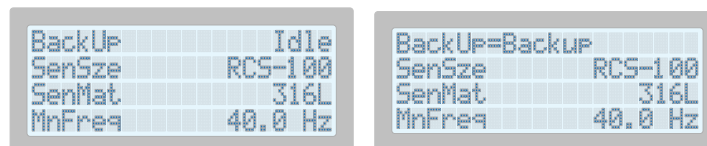

Figure 62: Backup triggered from menu

6. Press and hold **Enter** to save the change and initiate the command. *WARNING* will appear on the bottom right of the display. This is a temporary indication a backup has been created.

### Backup Using RCT Console Software

Refer to the RCT Console Help file for information on how to back up through the RCT Console.

## BACKUP ENABLED PARAMETERS

The following parameters, if altered, will cause the transmitter to prompt a backup request command.

Address	Parameter	Address	Parameter
5	Transmitter Serial	115	Brix A3
6	Sensor Serial	116	Brix B1
16	Sensor Size	117	Brix B2
20	Meter Zero	118	Brix B3
37	Application Menu Control	123	Current#1 Output Setup
39	Density Correction Temperature	124	Current#2 Output Setup
41	CPU Frequency Correction	125	Frequency #I Output Setup
44	Phase Correction	133	Pulse Width
46	Flow Factor	138	Batch Menu
47	Maximum Mass Flow Rate	158	PID Menu
48	Zero Mass Flow Limit	181	Brix C1
49	Mass Flow Temperature Factor	182	Brix C2
50	Mass Flow Linearization Factor	186	Driver Gain
51	RTD1 Linearization Offset	187	Driver Derivation Factor
52	RTD1 Linearization Slope	188	Driver Integrating Factor
66	Base Temperature	201	COM1 Protocol
72	Density Alpha	227	Analog 1 Slope
73	Density Beta	228	Analog 1 Offset
75	Density KT Factor	230	Current#3 Output Setup
76	Density OW Factor	232	Analog 2 Slope
79	Concentration Menu	233	Analog 2 Offset
87	Net Flow Menu	234	RTD2 Linearization Offset
88	Totalizer Menu	235	RTD2 Linearization Slope
89	Alarm Menu	260	COM2 Protocol
112	Brix Mode	261	MAINCPU Crystal Frequency
113	Brix A1	262	Voltage Reference
114	Brix A2	271	IFCPU Crystal Frequency

Table 5: Backup enabled parameters

## RESET TOTALS HELP

You can reset totals from two locations:

- Main Menu > Measurement
  - Main Menu > Totals
1. Move to the desired menu.
  2. Press the arrow keys to move *RESET TOTALS* to the active line.
  3. Press and hold **Enter** to reset totals.

## FLOW DIRECTION

If the fluid flow is reverse of the meter flow and reading negative flow when positive flow is desired, change the mass flow linearization factor *mLinFct* from 1 to -1. Changing this parameter requires the proper security level.

1. Navigate to *Main Menu > SETUP > CALIBRATION > FLOW*.
2. Scroll until *mLinFct* is the first line on the screen.
3. Press and hold **ENTER** to enter the editing mode.
4. Scroll down to change positive (+) to negative (-) and press **ENTER** to accept the change.
5. To exit the menus, press **MENU** at each new menu. A prompt to back up the parameters appears before exiting the Main Menu and returning to the Home Screen.

## OUTPUT CONFIGURATION

### Current Outputs

RCTN transmitters have three current outputs and the RCTX transmitters have two current outputs plus a current output with HART (if the HART option is installed) that can send signals to peripheral devices (such as loop-powered remote indicators, controllers and similar equipment). These outputs may be independently set by the user, via software or keypad, for any range between 0...22 mA with 4...20 mA being the default. The maximum load (loop) impedance for each output is 500  $\Omega$ .

Normally the *Iout1* output is set for mass flow. However, this can represent other parameters. In these cases, the units of measure are (appropriately) different.

The *Main Menu > SETUP > SYSTEM IO* menu contains three current output channels:

- *CURRENT1 SETUP*
- *CURRENT2 SETUP*
- *CURRENT3 SETUP*

**NOTE:** *Table 6* describes Current Output 1 setup. The setup for Current Output 2 and Current Output 3 are similar.

Description of column headers in the following table:

- Value = Write value or selection
- Unit / Decimal = Change units or the number of digits after the decimal, if appropriate

Parameter	Addr	Description	Password Levels								
			Operator			Technician			Engineer		
			Read	Write		Read	Write		Read	Write	
Value	Unit / Decimal	Value		Unit / Decimal	Value		Unit / Decimal				
IOut1	120	Current output on current channel 1	X		X	X		X	X		X
ID	—	Parameter ID	X			X	—		X	—	
IValueMn	—	Current value associated with minimum flow	X		X	X	X	X	X	X	X
IvluMx	—	Current value associated with maximum flow	X		X	X	X	X	X	X	X
ValueMn	—	Parameter value associated with minimum flow	X		X	X	X	X	X	X	X
ValueMx	—	Parameter value associated with maximum flow	X		X	X	X	X	X	X	X
TstOut	—	Tests current channel 1 output	X		X	X	X	X	X	X	X
+Alt1	126	Enables alternate current on current channel 1 output	X			X	—		X	—	

Table 6: Current output 1 setup

## Frequency, Pulse and PWM Outputs

The frequency channel has three modes. The first is straight frequency output in the range of 63...10,000 Hz with 3000 Hz being the typical maximum. The second is a pulse output (one pulse per every defined mass unit). The third is a PWM output that varies the ratio of on time to a set period. The output can be configured for one of the three modes.

The frequency channel can drive external devices such as rate indicators, batch totalizers and similar devices.

Access the frequency setup parameters through the *Main Menu* > *SETUP* > *SYSTEM I/O* > *FREQUENCY SETUP* menu.

Selecting *FREQUENCY SETUP* enters the frequency/pulse out menu which contains the items shown in *Table 7*.

**NOTE:** The availability of the items depends on the password level selected.

Description of column headers in the following table:

- Value = Write value or selection
- Unit / Decimal = Change units or number of digits after the decimal, if applicable

Parameter	Addr	Description	Password Levels								
			Operator			Technician			Engineer		
			Read	Write		Read	Write		Read	Write	
				Value	Unit/Decimal		Value	Unit/Decimal		Value	Unit/Decimal
FrqOut	122	Frequency output	X		X	X		X	X		X
FrqOEN	129	Enables frequency 1 output	X			X		—	X		—
ID	—	Parameter ID for frequency 1 output	X			X		—	X		—
FrqMn	—	Frequency value associated with minimum flow	X		X	X	X	X	X	X	X
FrqMx	—	Frequency value associated with maximum flow	X		X	X	X	X	X	X	X
ValueMn	—	Parameter value associated with minimum flow	X		X	X	X	X	X	X	X
ValueMx	—	Parameter value associated with maximum flow	X		X	X	X	X	X	X	X
TstOut	—	Tests frequency 1 output	X		X	X	X	X	X	X	X
+AltFrq	128	Enables alternate frequency and PWM on frequency 1 output	X			X		—	X		—
PlsOM	130	Pulse output mode	X			X		—	X		—
PlsID	131	Pulse output item	X			X		—	X		—
PlsSze	132	Pulse size	X		X	X	X	X	X	X	X
PlsWth	133	Pulse width	X			X		—	X		—
PWMPer	—	Controls the period of PWM frequency in ms	X			X		—	X		—
PWMAlt	—	Simulates an output based on percent of PWMPer	X		X	X	X	X	X	X	X

Table 7: Frequency/pulse/PWM outputs

# PID

RCT transmitters are also supplied with a built-in PID controller. This can be used for a large number of control applications, greatly simplifying the installation.

Description of column headers in the following tables:

- Value = Write value or selection
- Unit / Decimal = Change units or number of digits after the decimal, if applicable

Parameter	Addr	Description	Password Levels								
			Operator			Technician			Engineer		
			Read	Write		Read	Write		Read	Write	
				Value	Unit / Decimal		Value	Unit / Decimal		Value	Unit / Decimal
PSpt	151	PID Setpoint	X	X	X	X	X	X	X	X	X
PID EN	150	PID Enable/Disable	X		-	X		-	X		-
PID ID	159	PID Parameter Identifier	X			X			X		-
POut	152	Output Percentage of PID Controller	X		X	X		X	X		X
SamTim	153	Sampling Time	X			X			X		-
PGn	154	PID Gain	X			X			X	X	
PDer	155	PID Derivative	X			X			X	X	
Plnt	156	PID Integer	X			X			X	X	
POffset	157	PID Offset	X	X		X			X	X	
PHold	259	PID Hold	X		-	X		-	X		-

Table 8: PID menu parameters

## Modify the PID Control Settings

From the *Main Menu*, select **PID**.

If the *PID* menu is not listed in the menu, then enable it by selecting *SETUP > Menus > MnuPID*.

## PID Control Explanations

**PID output control variable (Pout):** Is the output of the PID in percentage.

$$Pout = Pout_{Previous} + PGn * Error + Plnt * \Sigma(Errors) + PDer * \Delta Error + POOffset$$

Where the Error = PSpt – (measured value of PID ID)

**Proportional (PGn):** Gives largest change in the output for a given change in error. When increased, decreases rise time and steady state error along with increasing the overshoot and changes the settling time by a little bit. As it is increased it also lowers the stability of the system.

**Integral (Plnt):** The integral takes into account both the magnitude and duration of the error to change the system. When increased, decreases rise time and eliminates steady state error however increases both the overshoot and the settling time. As with the proportional gain, as it is increased it lowers the stability of the system.

**Derivative (PDer):** The derivative attempts to predict system behavior and modify accordingly. When increased, decreases the overshoot and settling time along with delivering a minor changing the rise time and not affecting the steady-state error. Providing it stays relatively small, increasing will improve the stability of the system.

**Offset (POffset):** The offset value (in percentage) added to the PID control

**Process variable assignment (PID ID):** PID ID is the parameter of the process variable you want to measure. The process variable can be a direct measurement of the Coriolis meter (i.e. mFlo, Dens) or an external device wired to an analog input: AnIn1 or AnIn2.

PID		
Parameter	Factory Default	New Setting
PSpt	0	<set during operation >
PID EN	Disabled	Enabled
PID ID	59, mFlo	<user set >
SamTim	20 ms	<user set >
PGn	10	<user set >
PDer	-2	<user set >
Plnt	2	<user set >

## Enabling and Setting Values on the 4...20 mA Output Port

1. From the *Main Menu*, select *Setup > System I/O*.
2. To assign an analog current output to the PID control variable, set the ID of the *IOutput* to **Pout**, enable the *IOutput* and set the scaling parameters.

<b>IOutput 1 (or IOutput 2 or IOutput 3)</b>		
<b>Parameter</b>	<b>Factory Default</b>	<b>New Setting</b>
ID	59, mFlo	152, Pout
EN	Disabled	Enabled
IValueMn	4 mA	<user set >
IValueMx	20 mA	<user set >
ValueMn	0	<user set >
ValueMx	~1325 lb/min	<user set >
TstOut	0	<user set >

As an example for controlling a valve position in line with the Coriolis meter, the PID parameters were set at:

<b>PID</b>		
<b>Parameter</b>	<b>Factory Default</b>	<b>New Setting</b>
PSpt	0	<set during operation >
PID EN	Disabled	Enabled
PID ID	59, mFlo	59, mFlo
SamTime	20 ms	50 ms
PGn	10	2
PDer	-2	0.5
Pint	2	0.25

<b>IOutput 1</b>		
<b>Parameter</b>	<b>Factory Default</b>	<b>New Setting</b>
ID	59, mFlo	152, Pout
EN	Disabled	Enabled
IValueMn	4 mA	4 mA
IValueMx	20 mA	20 mA
ValueMn	0	0
ValueMx	~1325 lb/min	<max flowt >
TstOut	0	4 mA

## USER ALARMS

RCT transmitters include up to six user-defined alarms. The alarms can be programmed to trigger when process parameters exceed preset limits set by the operator.

Symbol	Default Setting	
Alarm-A	Mass flow alarm	mFlo
Alarm-B	Totalizer alarm	mTot
Alarm-C	Density alarm	Dens
Alarm-D	Temp. alarm	Temp 1
Alarm-E	PID alarm	POut
Alarm-F	Volumetric flow alarm	vTot

Table 9: User alarm menu

1. From the *Home* screen, press **Menu** to enter into the top level Main Menu. Using **Up** or **Down**, scroll until *ALARMS* is in the active line and press **Enter** to access the alarms menu.

**NOTE:** The alarms menu item *MnuAlarm* must be enabled for the alarms menu to be visible: See "*Enable/Disable Hidden Menus*" on page 51.

2. From the *Alarm* prompt, press **Up** or **Down** until the desired alarm (Alarm A...F) shows on the active line of the display.
3. Press **Enter** to access the specific alarm parameters list.
4. Use **Up** or **Down** to select the specific alarm parameter that is to be changed by placing it in the active line.
5. Press and hold **Enter** to edit the alarm parameter located in the active line. Use **Up** and **Down** to scroll through the alarm ID, to disable the alarm or change the values that trigger the alarm high and low limits.
6. To enable the alarm, scroll until *EN (x)* is in the active line. Press and hold **Enter** to edit parameter. Change the value from *Disable* to *Enable*.
7. Press and hold **Enter** to set the alarm.

Symbol	Description	Units
ID(x)	Alarm pointer item (A, B, C, D, E or F)	XXX (Parameter ID), (Parameter Name)
EN(x)	Enable or disable alarm (A, B, C, D, E or F)	Enable or Disable
XLo	Low limit	User assigned values of parameter that is assigned to that alarm.
XHi	High limit	

Table 10: Alarm variables

In addition to the high and low limits for each alarm, you can change the item that triggers the alarm. However, the message displayed when the alarm triggers remains as the default setting (see *Table 10*). When you go into the *Warning* screen to see alarm details, low/high flow will be shown. This message can be changed via the RCT Console.

### Example

If alarm A is set to work on tube frequency (*Freq*), then if the frequency increases above the preset value, the alarm triggers and *WARNING* is displayed.

Alarm outputs are normally connected to peripheral devices which are either resistive load devices or logic level sensing. Resistive load devices (in other words relays, indicator lamps, piezo alarms) are connected as shown in *Figure 39 on page 38 through Figure 45 on page 39*.

**NOTE:** These devices must have a minimum impedance of greater than 150  $\Omega$  or must be current limited to less than 100 mA maximum.

Logic load sensing devices, peripheral devices, PLCs or other TTL/CMOS compatible inputs should be connected as shown in *Figure 45*.

# COMMUNICATION WIRING AND SETUP

All RCT1000 transmitters include EIA-485 and USB programming ports.

**NOTE:** An RS485 Terminator resistor is provided for when end-of-line termination is required. The RCTX and RCTX with Display transmitters are shipped from factory with the shunt jumper in "Not Terminated" position.

## EIA-485 Port

The EIA-485 port is used for network connections and supports two protocol options: Modbus RTU and BMI Massmeter.

## USB Programming Port

The USB programming port is used for connecting a computer with RCT Console configuration and diagnostic software to the RCT transmitter. The USB programming port supports two protocol options: Modbus RTU and BMI Massmeter. RCT Console defaults to BMI Massmeter but can be changed to Modbus RTU if required. Both ports remain active while RCT Console is communicating with the transmitter through the USB port. The transmitter may not be able to respond to all requests if both the EIA-485 and USB programming ports are busy.

## EIA-485 / USB Configuration

### RCTX Transmitters

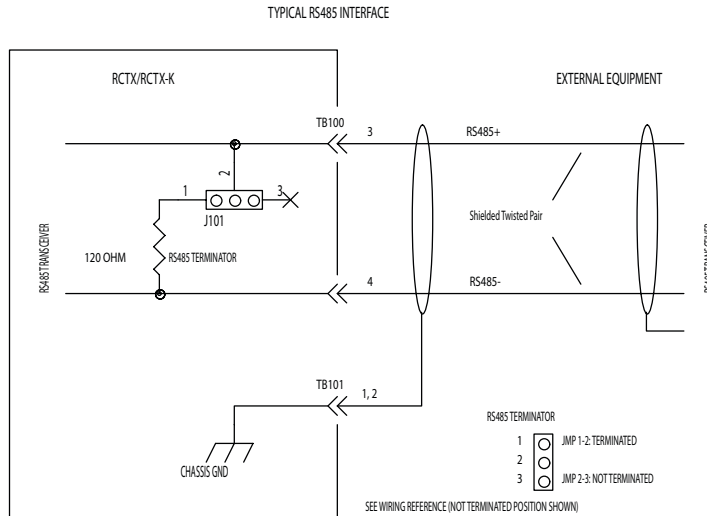

Figure 63: Typical RS485 wiring diagram

### RCTN Transmitters

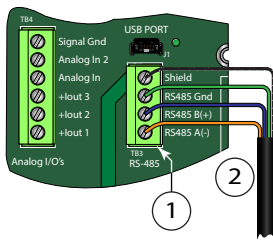

Figure 64: EIA-485 wiring diagram

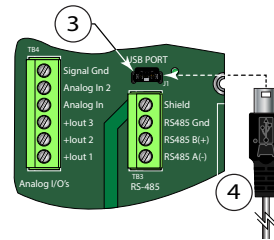

Figure 65: USB wiring diagram

1	Connector	TB3-RS485
2	Wiring	Field-RS485
3	Connector	USB Mini-B
4	Cable	USB Mini-B



## Configuration Procedure for All Transmitter Types

Parameters are available to configure the EIA-RS485 and USB ports. Engineer (PW3) level access is required to change the default settings.

Parameter selection is in menu *SETUP > SYSTEM IO > COM PORTS*

*ComAdd* is the parameter for the network device address.

1. To change the network device address, scroll to parameter *ComAdd* then press and hold **Enter** until the cursor starts flashing under the first digit of the address.
2. Press and hold **Up** to move the cursor to the correct digit.
3. Use **Up** or **Down** to increment the address number.
4. Press and hold **Enter** for a Long Press to save the change, or press and hold **Menu/Exit** to cancel the edit(s) and return to *COM PORTS* parameter screen.

*ComPr1* is the parameter for the protocol selection.

1. To change the protocol selection, scroll to parameter *ComPr1* then press and hold **Enter**.
2. Press **Up** or **Down** to scroll to the appropriate option.
3. Press and hold **Enter** for a Long Press to save the change, or press and hold **Menu/Exit** for a Long Press to cancel the edit(s) and return to *COM PORTS* parameter screen.

*BaudRate* is the parameter for the baud rate setting. Valid baud rates are 1200, 2400, 4800, 9600, 19200 and 38400.

**NOTE:** The baud rate setting is common for all ports. If an optional communication card is used, then the baud rate must be set to 38400.

1. To change the network device address, scroll to *BaudRate* then press and hold **Enter**.
2. Press and hold **Up** to move the cursor to the correct digit.
3. Use **Up** or **Down** to increment the numbers in the baud rate parameter.
4. Press and hold **Enter** for a Long Press to save the change, or press and hold **Menu/Exit** to cancel the edit(s) and return to *COM PORTS* parameter screen.

## Optional HART Communication Card

See the "Coriolis Flow Meter HART Bidirectional Communication Protocol Data Access" user manual, available at [www.badgermeter.com](http://www.badgermeter.com).

## Optional Ethernet Communication Card

An optional Ethernet communication card can be ordered on the Coriolis transmitter by including the "E" designation in the Communication Protocol block in the part number construction. See the *Coriolis RCT1000 Product Data Sheet* for ordering information.

The Ethernet card supports both Modbus TCP/IP and EtherNet/IP protocols. Configuring the Ethernet IP address requires a computer with an Ethernet port.

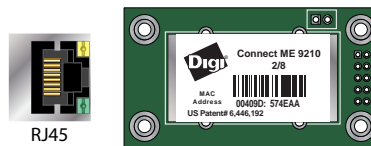

Figure 66: Ethernet card

## Ethernet Configuration

To configure the Ethernet settings, use a web browser on a PC with an Ethernet port. The transmitter parameters do not require any changes from the default settings for the Ethernet operations.

### COM PORTS Parameters

Validate the following parameters in menu: SETUP > SYSTEM IO > COM PORTS. Engineer (PW3) level access is required to change the settings.

**NOTE:** BaudRate is the parameter for adjusting the serial communications speed between the main board and RCT Console (Com Port 1), or between the main board and optional communication cards (Com Port 2). BaudRate must match the baud rate setting on the Ethernet communication card's internal web page. The default Baud Rate of 38400 is recommended. The serial communications baud rate / speed does not influence the integrated 10/100 Mbit Ethernet interface.

1. To change the baud rate, scroll to *BaudRate* then press and hold **Enter**.
2. Press and hold the **Up** arrow to move the cursor to the correct digit.
3. Press **Up** or **Down** to increment the numbers in the baud rate parameter.
4. Press and hold **Enter** for a long press to save the change, or press and hold **Exit** to cancel the change and return to *COM PORTS* parameter screen.

ComPr2 is the parameter for selecting the protocol used by the optional communication card installed (Com Port 2). ComPr2 must be set to "BMI Massmeter" for the Ethernet communications card.

1. To change the protocol selection, scroll to parameter *ComPr2*, then press and hold **Enter**.
2. Press **Up** or **Down** to scroll through the options.
3. Press and hold **Enter** for a long press to save the change, or press and hold **Exit** for a long press to cancel the change and return to the *COM PORTS* parameter screen.

## Configuring the Ethernet Communication Card

**NOTE:** Use an Ethernet crossover cable when connecting directly to a PC.

Connecting the PC to the Ethernet communication card:

1. Set the PC IP address to 192.168.0.xxx (except 192.168.0.100) with subnet mask 255.255.255.0.
2. Connect a PC to the Ethernet port with an Ethernet crossover cable.
3. Open a web browser and enter the default IP address **192.168.0.100** into the *URL* field. The following screen displays:

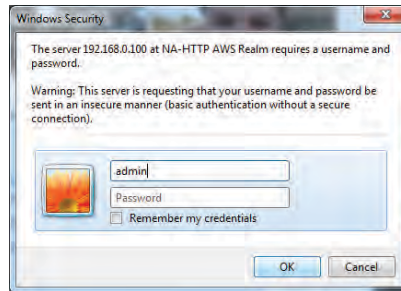

Figure 67: Windows security screen

4. Enter in one of the following user names:
  - a. admin
  - b. Admin
  - c. ADMIN
5. Leave the password entry blank and press **OK**.  
This is the default value from the factory and can be changed from the web page.
6. Change the IP address and other settings under the *IP v4 Settings* section.



Figure 68: IP v4 settings screen

7. Once the settings match the Modbus or Ethernet Network that you wish to connect to, exit the web browser. You can now connect it to a Modbus TCP/IP or Ethernet IP network.

# COMMUNICATIONS PROTOCOLS

## Modbus RTU

RCT1000 transmitters support reading and writing of a **single** parameter through function codes.

Modbus function code support:

- 03 (03 Hex), Read Holding Registers
- 16 (10 Hex), Preset Multiple Registers

Modbus starting address

- The starting address is the same as the parameter number.
- A single parameter may consist of up to 4 bytes of data.
- Only one parameter at a time may be requested.

The register corresponds to the parameter number +40001. For example, to read the mass flow rate (mFlo), which is parameter 59 (3B hex) and is a 32-bit floating point, the register is 40060-40061.

Slave Address	01
Function	03
Starting Address Hi	00
Starting Address Lo	3B
No. of Points Hi	00
No. of Points Lo	02
CRC Hi	B5
CRC Lo	C6

## HART

See the "Coriolis Flow Meter HART Bidirectional Communication Protocol Data Access" user manual, available at [www.badgermeter.com](http://www.badgermeter.com).

## EtherNet/IP

### Overview

EtherNet/IP is an open industrial Ethernet network with Common Industrial Protocol (CIP™) at its upper layers. ODVA manages the development of CIP network technologies and standards ([www.odva.org](http://www.odva.org)).

Coriolis transmitter supports explicit messages via the object model.

Add-On profile (AOP) for Allen-Bradley ControlLogix and CompactLogix is supported by the RCT1000 Coriolis .eds file. If you have a version of Studio 5000 that supports AOPs, then the addresses and tags are automatically configured when the .eds file is imported into Studio 5000.

### EtherNet/IP Addressing

The following table describes all of the data types used.

USINT	Unsigned Short Integer (8-bit)	STRING	Character String (1 byte per character)
UINT	Unsigned Integer (16-bit)	SHORT STRINGNN	Character String (1st byte is length; up to NN characters)
UDINT	Unsigned Double Integer (32-bit)	BYTE	Bit String (8-bits)
SINT	Signed Integer (8-bit)	WORD	Bit String (16-bits)
INT	Signed Integer (16-bit)	DWORD	Bit String (32-bits)
DINT	Signed Integer (32-bit)	REAL	IEEE 32-bit Single Precision Floating Point

Table 11: Data types

## Identity Object (01HEX – 1 Instance)

The following tables contain the attribute, status, and common services information for the Identity Object.

### Class Attributes (Instance 0)

Attribute ID	Name	Data Type	Data Value	Access Rule
1	Revision	UINT	1	Get

### Instance Attributes (Instance 1)

Attribute ID	Name	Data Type	Data Value	Access Rule
1	Vendor Number	UINT	1326	Get
2	Device Type	UINT	2B <sub>HEX</sub>	Get
3	Product Code Number	UINT	2	Get
4	Product Major Revision Product Minor Revision	USINT USINT	02 <sub>HEX</sub> 23 <sub>HEX</sub>	Get
5	Status	WORD	See Below	Get
6	Serial Number	UDINT	Unique 32 Bit Value	Get
7	Product Name	SHORT STRING32	RCT1000 Coriolis Meter	Get

### Common Services

Service Code	Implemented for		Service Name
	Class Level	Instance Level	
05 <sub>HEX</sub>	No	Yes	Reset
0E <sub>HEX</sub>	Yes	Yes	Get_Attribute_Single
10 <sub>HEX</sub>	No	Yes	Set_Attribute_Single

## Message Router Object (02HEX – 1 Instance)

\*\*\*No supported services or attributes\*\*\*

## Assembly Object (04HEX – 2 Instances)

### Class Attributes (Instance 0)

Attribute ID	Name	Data Type	Data Value	Access Rule
1	Revision	UINT	2	Get
2	Max Instance	UINT	255	Get

### Input Instance Attributes (Instance 100)

Attribute ID	Name	Data Type	Default Data Value	Access Rule
3	Input Data	USINT[80]	0	Get

**Input Instance 100 – Input Data**

<b>Assembly Index</b>	<b>Coriolis Parameter Address</b>	<b>Name</b>	<b>Data Type</b>
0 - 3	59	Mass Flow Rate	REAL
4 - 7	80	Mass Totalizer	REAL
8 - 11	100	Volumetric Flow Rate	REAL
12 - 15	101	Volumetric Total	REAL
16 - 19	65	Temperature #1	REAL
20 - 23	136	Temperature #2	REAL
24 - 27	70	Density	REAL
28 - 31	60	Tube Frequency	REAL
32 – 35	184	Driver Output	REAL
36 – 39	183	Coil A Voltage	REAL
40 – 43	185	Coil B Voltage	REAL
44 – 47	58	Percentage Mass Flow	REAL
48 – 63	13	Error Record	UINT16[8]
64 – 67	90	Batch Totalizer	REAL
68 – 71	93	Batch Setpoint	REAL
72 – 73	94	Batch Mode	UINT16
74 – 75	99	Batch Type	UINT16
76 – 79	95	Batch Timing Pre-Trigger	REAL
80 – 83	96	Batch Quantity Pre-Trigger	REAL
84 – 87	97	Batch Preset	REAL
88 – 91	195	Batch Preset 1	REAL
92 – 95	196	Batch Preset 2	REAL
96 – 99	197	Batch Preset 3	REAL
100 – 103	198	Batch Preset 4	REAL
104 – 107	199	Batch Preset 5	REAL
108 – 111	200	Batch Preset 6	REAL
112 – 115	256	Batch Time	REAL
116 – 123	216	Time	STRING[8]
124 – 131	217	Date	STRING[8]
132 – 135	151	PID Setpoint	REAL
136 – 139	152	PID Output	REAL
140.0	81	Reset Mass Totalizer	BOOL
140.1	n/a	Reserved	BOOL
140.2	150	PID Controller	BOOL
140.3	32	Suspend Batch	BOOL
140.4	91	Start Batch	BOOL
140.5	92	Stop Batch	BOOL
140.6	n/a	Reserved	BOOL
140.7	7	Reset Transmitter	BOOL
141 – 143	n/a	Reserved to maintain 32-bit alignment	n/a

**Output Instance Attributes (Instance 112)**

Attribute ID	Name	Data Type	Default Data Value	Access Rule
3	Output Data	USINT[44]	0	Get / Set

**Output Instance 112 – Output Data**

Bytes	Coriolis Parameter Address	Name	Data Type
0 - 3	93	Batch Setpoint	REAL
4 - 5	94	Batch Mode	UINT16
6 - 7	99	Batch Type	UINT16
8 - 11	95	Batch Timing Pre-Trigger	REAL
12 - 15	96	Batch Quantity Pre-Trigger	REAL
16 - 19	97	Batch Preset	REAL
20 - 23	195	Batch Preset 1	REAL
24 - 27	196	Batch Preset 2	REAL
28 - 31	197	Batch Preset 3	REAL
32 - 35	198	Batch Preset 4	REAL
36 - 39	199	Batch Preset 5	REAL
40 - 43	200	Batch Preset 6	REAL
44 - 47	151	PID Setpoint	REAL
48.0	81	Reset Mass Totalizer	BOOL
48.1	n/a	Reserved	BOOL
48.2	150	PID Controller	BOOL
48.3	32	Suspend Batch	BOOL
48.4	91	Start Batch	BOOL
48.5	92	Stop Batch	BOOL
48.6	n/a	Reserved	BOOL
48.7	7	Reset Transmitter	BOOL
49 - 53	n/a	Reserved to maintain 32-bit alignment	n/a

**Output Only Heartbeat (Instance 253)**

**Input Only Heartbeat (Instance 254)**

**Listen Only Heartbeat (Instance 255)**

**Common Services**

Service Code	Implemented for		Service Name
	Class Level	Instance Level	
0EHEX	Yes	Yes	Get_Attribute_Single
10HEX	No	Yes	Set_Attribute_Single

**Connection Manager Object (06HEX)**

\*\*\*No supported services or attributes\*\*\*

### TCP Object (F5<sub>HEX</sub> – 1 Instance)

The following tables contain the attribute and common services information for the TCP Object.

#### Class Attributes

Attribute ID	Name	Data Type	Data Value	Access Rule
1	Revision	UINT	2	Get

#### Instance Attributes

Attribute ID	Name	Data Type	Default Data Value	Access Rule
1	Status	DWORD	1	Get
2	Configuration Capability	DWORD	0	Get
3	Configuration Control	DWORD	0	Get
4	Physical Link Object Structure of: Path Size Path	UINT Array Of WORD	2 0x20F6 0x2401	Get
5	Interface Configuration Structure of: IP Address Network Mask Gateway Address Name Server Name Server 2 Domain Name Size Domain Name	UDINT UDINT UDINT UDINT UDINT UINT STRING	varies varies varies 0 0 0 0	Get
6	Host Name Structure of: Host Name Size Host Name	UINT STRING	0 0	Get

#### Common Services

Service Code	Implemented for		Instance Level
	Service Name	Class Level	
0E <sub>HEX</sub>	Yes	Yes	Get_Attribute_Single



## Ethernet Link Object (F6<sub>HEX</sub> – 1 Instance)

The following tables contain the attribute and common services information for the Ethernet Link Object.

### Class Attributes

Attribute ID	Name	Data Type	Data Value	Access Rule
1	Revision	UINT	3	Get

### Instance Attributes

Attribute ID	Name	Data Type	Default Data Value	Access Rule
1	Interface Speed	UDINT	varies	Get
2	Interface Flags	DWORD	varies	Get
3	Physical Address	USINT Array[6]	varies	Get

### Common Services

Service Code	Implemented for		Service Name
	Class Level	Instance Level	
OEHEX	Yes	Yes	Get_Attribute_Single

## Modbus TCP/IP Addressing

Modbus TCP/IP is an open industrial Ethernet protocol that is managed by the Modbus Organization for the Modbus standards ([www.modbus.org](http://www.modbus.org)) and ODVA for the integration of Modbus devices into the CIP architecture ([www.odva.org](http://www.odva.org)).

Coriolis transmitter supports both Modbus and CIP model data addressing.

### Definitions

<b>Data Type</b>	REAL – IEEE 32-bit Floating Point UINT8 – unsigned 8 bit value (byte) UINT16 – unsigned 16 bit value (word) STRING – String of up to 16 characters ARRAY8 – Array of eight UINT8 data values
<b>Update Rate</b>	All parameters are read once at power up (or loss of communications to the meter). Read Once – Read only once at power up or loss of communications Read High – Read all “Read High” parameters every scan Read Low – Read one “Read Low” parameter every scan Write High – Write as immediately as possible Wr Low – Write one “Wr Low” parameter every scan Never – not accessed

### Common Parameters Group

Coriolis Parameter Address	Description	Modbus Start	Modbus End	Data Type	Update Rate
59	Mass Flow Rate	40100	40101	REAL	Read High
80	Mass Totalizer	40102	40103	REAL	Read High
100	Volumetric Flow Rate	40104	40105	REAL	Read High
101	Volume Total	40106	40107	REAL	Read High
65	Temperature #1	40108	40109	REAL	Read Low
136	Temperature #2	40110	40111	REAL	Read Low
70	Density	40112	40113	REAL	Read High
60	Tube Frequency	40114	40115	REAL	Read Low
184	Driver Output	40116	40117	REAL	Read Low
183	Coil A Voltage	40118	40119	REAL	Read Low
185	Coil B Voltage	40120	40121	REAL	Read Low
58	Percentage Mass Flow	40122	40123	REAL	Read Low
13	Error Record	40124	40131	UINT16[8]	Read Low

### Density Parameters Group

Coriolis Parameter Address	Description	Modbus Start	Modbus End	Data Type	Update Rate
70	Density	40200	40201	REAL	Read High
71	Specific Gravity	40202	40203	REAL	Read High
110	Density of Component A	40204	40205	REAL	Read High
111	Density of Component B	40206	40207	REAL	Read High

**Totalizer Parameters Group**

Coriolis Parameter Address	Description	Modbus Start	Modbus End	Data Type	Update Rate
80	Mass Totalizer	40300	40301	REAL	Read High
85	Net Mass Totalizer	40302	40303	REAL	Read Low
239	Mass Totalizer Forward	40304	40305	REAL	Read Low
240	Mass Totalizer Reverse	40306	40307	REAL	Read Low
57	Net Volumetric Flow Rate	40308	40309	REAL	Read High
82	Overall Mass Totalizer	40310	40311	REAL	Read Low
83	Mass Totalizer Wrap Limit	40312	40313	REAL	Read Low
31	Totalizer Wrap Count	40314	—	UINT16	Read Low

**Batch Parameters Group**

Coriolis Parameter Address	Description	Modbus Start	Modbus End	Data Type	Update Rate
90	Batch Totalizer	40400	40401	REAL	Read High
93	Batch Setpoint	40402	40403	REAL	R/W High
94	Batch Mode	40404	—	UNIT16	R/W High
95	Batch Timing Pre-Trigger	40406	40407	REAL	R/W High
96	Batch Quantity Pre-Trigger	40408	40409	REAL	R/W High
97	Batch Preset	40410	40411	REAL	R/W High
99	Batch Controls Batching Source Type	40412	—	UINT16	R/W High
195	Batch Preset 1	40414	40415	REAL	R/W Low
196	Batch Preset 2	40416	40417	REAL	R/W Low
197	Batch Preset 3	40418	40419	REAL	R/W Low
198	Batch Preset 4	40420	40421	REAL	R/W Low
199	Batch Preset 5	40422	40423	REAL	R/W Low
200	Batch Preset 6	40424	40425	REAL	R/W Low
256	Batch Time	40426	40427	REAL	Read High

**Overhead Parameters Group**

Coriolis Parameter Address	Description	Modbus Start	Modbus End	DATA TYPE	UPDATE RATE
0	Software Date	40500	40507	STRING[8]	Read Low
3	Software Version	40508	40515	STRING[14]	Read Low
4	Sensor Type	40516	40523	STRING[6]	Read Low
5	Transmitter Serial	40524	40531	STRING[6]	Read Low
6	Sensor Serial	40532	40539	STRING[6]	Read Low
64	Meter Zero in Mass Flow Rate	40540	40541	REAL	Read Low
140	Password Level	40542	—	UNIT16	Read Low
142	User Password	40544	—	UINT16	R/W Low
216	Time	40546	40553	STRING[8]	Read Low
217	Date	40554	40561	STRING[8]	Read Low
223	Tag	40562	40569	STRING[8]	Read Low
224	Descriptor	40570	40577	STRING[16]	Read Low
225	Account Number	40578	40585	STRING[8]	Read Low
42	Error History	40586	40697	STRING[224]	Read Low

**Diagnostic Parameters Group**

Coriolis Parameter Address	Description	Modbus Start	Modbus End	DATA TYPE	UPDATE RATE
23	Average Meter Zero	40700	40701	REAL	Read Low
25	Meter Zero Range	40702	40703	REAL	Read Low
28	Zero Calibration Counter	40704	—	UNIT16	Read Low
30	Raw Phase	40706	40707	REAL	Read Low
33	Phase	40708	40709	REAL	Read Low
45	Raw Mass Flow Rate	40710	40711	REAL	Read Low
183	Coil A Voltage	40712	40713	REAL	Read Low
184	Driver Output	40714	40715	REAL	Read Low
185	Coil B Voltage	40716	40717	REAL	Read Low
186	Driver Gain	40718	40719	REAL	Read Low
187	Driver Derivation Factor	40720	40721	REAL	Read Low
188	Driver Integrating Factor	40722	40723	REAL	Read Low
191	Driver Ratio	40724	40725	REAL	Read Low
192	Drive A Mode	40726	—	UNIT16	Read Low
193	Drive B Mode	40728	—	UNIT16	Read Low
237	Average Coil Voltage	40730	40731	REAL	Read Low
257	Mass Elapsed Time	40732	40733	REAL	Read Low
263	Mass Increment	40734	40735	REAL	Read Low
264	Processing Time of IFCPU Data.	40736	40737	REAL	Read Low
266	Invalid Phase Count	40738	40739	REAL	Read Low
267	Count of IFCPU Records	40740	40741	REAL	Read Low
268	Count of Rejected IFCPU Records	40742	40743	REAL	Read Low

### PID Parameters Group

Coriolis Parameter Address	Description	Modbus Start	Modbus End	DATA TYPE	UPDATE RATE
151	PID Setpoint	40800	40801	REAL	R/W High
152	PID Output	40802	40803	REAL	Read High

### Coil Parameters Group

Coriolis Parameter Address	Description	Modbus Coil	DATA TYPE	UPDATE RATE
81	Reset Mass Totalizer	1	INT1	R/W High
150	PID Controller	3	INT1	R/W High
32	Suspends Batch	4	INT1	R/W High
91	Start Batch	5	INT1	R/W High
92	Stop Batch	6	INT1	R/W High
7	Reset Transmitter	8	INT1	R/W High

## Modbus CIP Model Addressing

### Definitions

<b>DATA TYPE</b>	REAL – IEEE 32-bit Floating Point UINT8 – unsigned 8 bit value (byte) UINT16 – unsigned 16 bit value (word) STRING – String of up to 16 characters ARRAY8 – Array of eight UINT8 data values
<b>UPDATE RATE</b>	All parameters are read once at power up (or loss of communications to the meter). Read Once – Read only once at power up or loss of communications Read High – Read all “Read High” parameters every scan Read Low – Read one “Read Low” parameter every scan Write High – Write as immediately as possible Wr Low – Write one “Wr Low” parameter every scan Never – not accessed

### Common Parameters Group

Coriolis Parameter Address	Description	Class	Instance	Attribute	Data Type	Update Rate
59	Mass Flow Rate	101	1	1	REAL	Read High
80	Mass Totalizer	101	1	2	REAL	Read High
100	Volumetric Flow Rate	101	1	3	REAL	Read High
101	Volumetric Totalizer	101	1	4	REAL	Read High
65	Temperature #1	101	1	5	REAL	Read Low
136	Temperature #2	101	1	6	REAL	Read Low
70	Density	101	1	7	REAL	Read High
60	Tube Frequency	101	1	8	REAL	Read Low
184	Driver Output	101	1	9	REAL	Read Low
183	Coil A Voltage	101	1	10	REAL	Read Low
185	Coil B Voltage	101	1	11	REAL	Read Low
58	Percentage Mass Flow Rate	101	1	12	REAL	Read Low
13	Error Record	101	1	13	UINT16[8]	Read Low

**Density Parameters Group**

Coriolis Parameter Address	Description	Class	Instance	Attribute	Data Type	Update Rate
70	Density	102	1	1	REAL	Read High
71	Specific Gravity	102	1	2	REAL	Read High
110	Density of Component A	102	1	3	REAL	Read High
111	Density of Component B	102	1	4	REAL	Read High

**Totalizer Parameters Group**

Coriolis Parameter Address	Description	Class	Instance	Attribute	Data Type	Update Rate
80	Resettable Mass Totalizer	103	1	1	REAL	Read High
85	Net Mass Totalizer	103	1	2	REAL	Read Low
239	Mass Totalizer Forward	103	1	3	REAL	Read Low
240	Mass Totalizer Reverse	103	1	4	REAL	Read Low
57	Net Volumetric Flow Rate	103	1	5	REAL	Read High
82	Overall Mass Totalizer	103	1	6	REAL	Read Low
83	Mass Totalizer Wrap Limit	103	1	7	REAL	Read Low
31	Totalizer Wrap Counter	103	1	8	UINT16	Read Low

**Batch Parameters Group**

Coriolis Parameter Address	Description	Class	Instance	Attribute	Data Type	Update Rate
90	Batch Totalizer	104	1	1	REAL	Read High
93	Batch Setpoint	104	1	2	REAL	R/W High
94	Batch Mode	104	1	3	UNIT16	R/W High
95	Batch Timing Pre-Trigger	104	1	4	REAL	R/W High
96	Batch Quantity Pre-Trigger	104	1	5	REAL	R/W High
97	Batch Preset	104	1	6	REAL	R/W High
99	Batch Type	104	1	7	UINT16	R/W High
195	Batch Preset 1	104	1	8	REAL	R/W Low
196	Batch Preset 2	104	1	9	REAL	R/W Low
197	Batch Preset 3	104	1	10	REAL	R/W Low
198	Batch Preset 4	104	1	11	REAL	R/W Low
199	Batch Preset 5	104	1	12	REAL	R/W Low
200	Batch Preset 6	104	1	13	REAL	R/W Low
256	Batch Time	104	1	14	REAL	Read High

**Device Overhead Parameters Group**

Coriolis Parameter Address	Description	Class	Instance	Attribute	Data Type	Update Rate
0	Software Date	105	1	1	STRING[8]	Read Low
3	Software Version	105	1	2	STRING[14]	Read Low
4	Sensor Type	105	1	3	STRING[6]	Read Low
5	Transmitter Serial	105	1	4	STRING[6]	Read Low
6	Sensor Serial	105	1	5	STRING[6]	Read Low
64	Metric Zero in Mass Flow Rate	105	1	6	REAL	Read Low
140	Password Level	105	1	7	UNIT16	Read Low
142	User Password	105	1	8	UINT16	R/W Low
216	Time	105	1	9	STRING[8]	Read Low
217	Date	105	1	10	STRING[8]	Read Low
223	Tag	105	1	11	STRING[8]	Read Low
224	Descriptor	105	1	12	STRING[16]	Read Low
225	Account Number	105	1	13	STRING[8]	Read Low
42	Error History	105	1	14	STRING[224]	Read Low

**Diagnostic Parameters Group**

Coriolis Parameter Address	Description	Class	Instance	Attribute	Data Type	Update Rate
23	Average Meter Zero	106	1	1	REAL	Read Low
25	Meter Zero Range	106	1	2	REAL	Read Low
28	Zero Calibration Counter	106	1	3	UNIT16	Read Low
30	Raw Phase	106	1	4	REAL	Read Low
33	Filtered Phase	106	1	5	REAL	Read Low
45	Raw Mass Flow Rate	106	1	6	REAL	Read Low
183	Coil A Voltage	106	1	7	REAL	Read Low
184	Driver Output	106	1	8	REAL	Read Low
185	Coil B Voltage	106	1	9	REAL	Read Low
186	Driver PID Gain	106	1	10	REAL	Read Low
187	Driver Derivation Factor	106	1	11	REAL	Read Low
188	Driver Integrating Factor	106	1	12	REAL	Read Low
191	Secondary Driver Ratio	106	1	13	REAL	Read Low
192	Drive A Mode	106	1	14	UNIT16	Read Low
193	Drive B Mode	106	1	15	UNIT16	Read Low
237	Average Coil Voltage	106	1	16	REAL	Read Low
257	Mass Elapsed Time	106	1	17	REAL	Read Low
263	Mass Increment	106	1	18	REAL	Read Low
264	Processing Time of IFCPU	106	1	19	REAL	Read Low
266	Invalid Phase Count	106	1	20	REAL	Read Low
267	Count of IFCPU Records	106	1	21	REAL	Read Low
268	Count of Rejected IFCPU Records	106	1	22	REAL	Read Low

**PID Parameters Group**

Coriolis Parameter Address	Description	Class	Instance	Attribute	Data Type	Update Rate
151	PID Setpoint	107	1	1	REAL	R/W High
152	PID Output	107	1	2	REAL	Read High

**Coil Parameters Group**

Coriolis Parameter Address	Description	Class	Instance	Attribute	Data Type	Update Rate
81	Reset Mass Totalizer	108	1	1	INT1	R/W High
150	PID Controller	108	1	2	INT1	R/W High
32	Suspend Batch	108	1	3	INT1	R/W High
91	Start Batch	108	1	4	INT1	R/W High
92	Stop Batch	108	1	5	INT1	R/W High
7	Reset Transmitter	108	1	6	INT1	R/W High

## TROUBLESHOOTING

### **⚠ WARNING**

**DO NOT REMOVE OR REPLACE FUSE WHEN IT IS ENERGIZED.**

### Identifying System Faults

When a fault is suspected:

1. Identify the general symptom and, if possible, the fault type by referring to the tables in this section.
2. When the fault has been identified, run through the checks detailed to correct the problem.
3. Re-zero the system.

### Red/Green LED Diagnostics

The red and green LEDs located on the transmitter are basic diagnostic indicators. Blinking LEDs can indicate an alarm level that can be used to identify the type of error that has occurred. The LEDs for the RCTN are located under the cover on the rear left portion of the main PCB.

#### Startup

On power up, it is normal for the red LED to be on (solid) for a few seconds, then blink for up to a minute while the sensor stabilizes. Anytime the red LED is on, or blinking after one minute past power up, a sensor problem exists that requires further investigation.

#### Blink Code

The LEDs are ON/OFF blink coded according to the following logic:

- Neither LED on: check for power. The LED should always be on.
- Red LED solid: severe failure (level 7 and 8).
- Red LED blinking: high or low limit indicator, a level 1 or 2 warning indication, no effect to accurate measurement.
- Green LED solid: the startup drive hammer is engaged.
- Green LED blinking slow (blink 1/sec): normal sensor diagnostic, no flow.
- Green LED blinking fast: normal sensor diagnostic, flow > low flow cut off (or need to zero).

When first installed, the meter must be filled and zeroed. Before zeroing, the green LED may indicate a flow rate. After the zero process it should indicate no flow by blinking at the slow rate.

#### Indicated Error Levels

Error levels 1 or 2 are high or low limit indications, such as one of the user settable alarm limits, one of the 4...20 mA limits or frequency output scaling limits is exceeded. Error levels 1...5 have no effect on accurate fluid measurement and totalization. Level 6...8 errors are more severe and accurate measurements cannot be achieved. Level 6...8 errors are:

- Measurement error (IFCPU)
- Tube frequency error
- RTD1 error
- No answer from IFCPU
- Sensor warning
- Driver overflow (> 100%)
- Flash CSC is bad. Flash backup created during startup



## Error Messages

**NOTE:** Under certain conditions, multiple error/alarm conditions may exist. If alarms keep appearing, identify the message and keep taking corrective action until all messages cease.

Error Message	Alarm Level	Error Description	Possible Faults and Corrections
Code Error Xram Error EEPROM Error Back-up Error Back-up Recovered	7-8	Microprocessor program error, RAM error, EEPROM error or EEPROM back-up error. An internal hardware problem exists. This is NOT user programmable	If errors are intermittent but persistent, there may be a hardware problem on the CPU board. A <i>System Reset</i> may recover functional memory. If not, call the factory.
No Sensor Signal	6	Sensor errors caused by RTD circuit, sensor tubes resonance error (frequency out of programmed limits or no detector signal(s) from sensor).  Common causes are open/shorted sensor coils, sensor wiring, defective interface or driver cards or incorrectly programmed frequency limits.	No feedback from the sensing coils ( <i>CoilA</i> and <i>CoilB</i> are less than 19 mV). The problem could be a bad drive coil, sensor wiring or defective driver or interface card.
Sensor Warning			Driver set point error. Sensor voltage outside of driver set point ( <i>DrvSpt</i> ) by $\pm 5\%$ .
Resonance Error			Tube resonance limits (70...200 Hz) are being exceeded. Sensor operating frequency exceeds <i>MxFreq</i> or is less than <i>MnFreq</i> .
Temp. Error			Temperature (RTD) measurement error. Problem could be sensor wiring, control/relay card problem or processor (CPU) card.
HW Limit IOut1 HW Limit IOut2 HW Limit IOut3 HW Limit on Freq.	5	Hardware limits exceeded on output channels, or attempt to zero the unit with flow present. These items are not user programmable, as they are functions of the hardware.	The computed output exceeds hardware limits. For example, if the HW limits on Freq analog channels are set to 0...20 mA and the channel is scaled to 0...100 lb/min on current channel two, if the flow is 105 lb/min, the computed output will exceed the programmed limit. In this case, <i>HW Limit IOut2</i> will be displayed.
IOut1 High/Low Limit IOut2 High/Low Limit IOut3 High/Low Limit Freq High/Low Limit	4	Software limits (set points) on the analog and frequency output channels are being exceeded.  PID output limits are being exceeded.	The computed output is below the programmed low limit or above the programmed high limit. For Example, if the upper span of the frequency was set to 1000 Hz at 1000 lb/min and the low end was 1015 lb/min the "Freq. High Limit" alarm would be displayed. If the flow was 90 lb/min, the "Freq. Low Limit" would be displayed.
Cntr. High/Low Limit			The computed output of the PID is greater than 100% (high alarm) or under 0% (low alarm)
Answer Error	3	Master/slave communication error on the serial communications port. These types of errors are only associated with serial communications. These errors would normally indicate a hardware or software failure in the host device.	The "master" unit transmitted to the "slave" unit, but received a message with an error in transmission or no answer was given.
Master Time-Out			The "master" unit transmitted to the "slave" unit, but received no reply
Master Duplex			The "master" unit transmitted to the "slave" unit, but received a reply before it was ready
COM-Duplex	2	Communication errors on the serial port. Serial port alarms turn on Opto #1, but are NOT user programmable. These alarms normally indicate a hardware problem in an external device.	A message was received in transmitting
COM-Command			An error in the command field
COM-Bad ID			An error in the ID field
COM-Bad Unit			An error in the units field
COM-Long Message			The received message was too long
COM-Short Message			The received message was too short
COM-Bad Conv			The floating point conversion was incorrectly formatted
COM-Bad Overrun			The character buffer over-ran or the baud rate may be wrong
COM-Timeout			Make sure connection, baud rates and addresses are correct.
COM-Bad SOH			
High/Low Flow High/Low Total High/Low Density High/Low Batch High/Low Temperature High/Low Alarm Limit	1	High and low limits for user defined alarms have been exceeded.	These alarms are user programmable with Opto #2 becoming active. The user may set the level(s) of data that would trigger the high or low alarm. For example, a batch alarm could be "tied" to the current batch amount, <i>BTot</i> , such that if a batch set point, <i>BSpt</i> , exceeding a receiving tanks capacity was entered, Opto #2 would activate (after <i>BTot</i> was exceeded highlighting the potential problem)
Zero Flow Error		The zero offset exceeds the low flow cutoff	Make sure the sensor is full of fluid and that there is no flow. Set <i>ZroL</i> to 5%. Try to zero the meter again. Reset <i>ZroL</i> to 1% after a successful zero.

Table 12: Error messages

## Troubleshooting Symptoms

Symptom	Possible Cause	Recommended Action
<b>Transmitter appears to not power up</b>	<b>Inadequate or no power Blown fuse</b>	Confirm power is available to the transmitter
		Measure voltage at the power terminals and check that the voltage matches the labels by the power terminals.
		Check that the power terminal block is firmly seated.
		For AC power, verify that the 115V/230V switch is in the correct position.
		Check the fuse near the power terminals. If fuse is blown, verify the voltage and polarity is correct and replace the fuse.
		Check that at least one LED on the main board is lit. If no LEDs are lit and the above actions are completed, replace the transmitter.
		Check that the ribbon cable from the main board to the keypad/display is firmly seated.
		Cycle power to the transmitter.
		Replace the transmitter if following the above actions does not resolve the issue.
<b>Mass flow reading appears to be too high or too low</b>	<b>Installation issues Process issues Improper zeroing of the meter Incorrect parameter settings</b>	Check the installation of the sensor according to installation instructions
		Run HealthTrack, the advanced function in RCT Console configuration software, to record critical measurements. Multiple, vital parameters can be viewed in a single snap-shot to assist with diagnosing issues.
		Check for mechanical vibrations or process loop instability. The impact of vibrations might be visible in the parameter. <ul style="list-style-type: none"> <li>System &gt; Sensor &gt; <i>CoilAv</i> should be 60 mV (<math>\pm 3</math> mV).</li> <li>Isolate the meter from the mechanical vibration.</li> </ul>
		Check process loop for entrained air which will impact the mass flow
		Check that there is no air in the sensor when zeroing the meter. Ensure that flow has completely stopped and all blocking valves are closed. Re-zero the meter.
		Verify that the calibration factors on the sensor are entered correctly to the transmitter <ul style="list-style-type: none"> <li>Set Up &gt; Calibration &gt; Flow &gt; <i>FloFct</i> (Flow Factor)</li> <li>Set Up &gt; Calibration &gt; Density parameters: <i>DAlpha</i> and <i>DBeta</i></li> </ul>
<b>Abnormal or Incorrect Mass Flow Readings</b>	<b>Installation issues Flow instability</b>	Run HealthTrack, the advanced function in RCT Console configuration software, to record critical measurements. Multiple, vital parameters can be viewed in a single snap-shot to assist with diagnosing issues.
		Check for mechanical vibrations. Impact of mechanical vibrations might be visible in the parameters.
		System > Sensor > <i>DrvOut</i> and <i>Freq</i> (tube frequency) readings. <i>DrvOut</i> should be between 10...95% and <i>Freq</i> should be between: <ul style="list-style-type: none"> <li>90...115 Hz (RCS005)</li> <li>170...220 Hz (RCS008)</li> <li>80...110 Hz (RCS018...050)</li> <li>40...90 Hz (RCS100...300)</li> </ul>
		The frequency stability should be better than $\pm 0.01$ Hz for a good measurement.
		Isolate the meter from the mechanical vibration.
		Another cause of instability is excessive flow rate. The flow shouldn't exceed 100% of the rating of the meter. Under <i>Main Menu &gt; MEASUREMENT</i> , check parameter <i>%mFlo</i> . If the value is greater than 100%, the process is exceeding the max flow rate of the meter
		Check process loop for variations of entrained air which will impact the mass flow
		Check for pump induced flow instability.
		Modify Mass Flow Dampening parameter to adjust the filtering <ul style="list-style-type: none"> <li>Set Up &gt; Calibration &gt; Flow &gt; <i>mDmp</i> can be adjusted from 1...99%</li> </ul>

Symptom	Possible Cause	Recommended Action
<b>Density reading appears to be incorrect</b>	<b>Installation issues Process loop issues Incorrect parameter settings</b>	Check process loop for entrained air and concentration of mix fluids which will impact the density
		Run HealthTrack, the advanced function in RCT Console configuration software, to record critical measurements. Multiple, vital parameters can be viewed in a single snapshot to assist with diagnosing issues.
		Check for mechanical vibrations. Impact of mechanical vibrations might be visible in the parameters.
		System > Sensor > <i>DrvOut</i> and <i>Freq</i> (tube frequency) readings. <i>DrvOut</i> should be between 10...95% and <i>Freq</i> should be between... <ul style="list-style-type: none"> <li>• 90...115 Hz (RCS005)</li> <li>• 170...220 Hz (RCS008)</li> <li>• 80...110 Hz (RCS018...050)</li> <li>• 40...90 Hz (RCS100...300)</li> </ul> <b>NOTE:</b> The frequency stability should be better than ± 0.01 Hz for a good measurement
		Verify that the calibration factors on the sensor are entered correctly to the transmitter: <ul style="list-style-type: none"> <li>• Set Up &gt; Calibration &gt; Flow &gt; <i>FloFct</i> (Flow Factor)</li> <li>• Set Up &gt; Calibration &gt; Density parameters: <i>DAAlpha</i> and <i>DBeta</i></li> </ul>
<b>Volumetric flow reading appears to be incorrect</b>	<b>Mass or density readings are incorrect</b>	Volumetric flow rate is calculated the mass flow rate divided by the density: $vFlo = mFlo/Dens$
<b>Sensor temperature (Temp1) reading appears to be incorrect</b>	<b>Incorrect wiring Cable issue RTD not functioning</b>	Verify sensor RTD is properly wired to transmitter (pins 2, 3 and 4).
		At the transmitter, disconnect the sensor wiring. Measure the resistance between brown and yellow/gray sensor wires. The resistance should be approximately 110 ohms at 77° F (25° C). The resistance will vary depending on the fluid temperature. The resistance between the yellow and gray sensor wires should be less than 5 ohms.
		If there appears to be an open or short at the transmitter end of the cable, remove the sensor cable from the sensor and measure the resistance from pin J to pins G/H on the sensor. The resistance should be 80...100 ohms for temperatures less than 32° F (0° C) and 100...180 for temperatures greater than 32° F (0° C). Depending on the fluid temperature, the resistance between pins G and H should be less than 1 ohm.
		Check the RTD Calibration constants in <i>Set Up &gt; Calibration &gt; Temperature</i> . <i>RTD1Of</i> should be 0 (± 5). <i>RTD1Sl</i> should be 1.00 (± 0.1).
		If there appears to be an open or short at the pins, replace the sensor.
		If the sensor measurements are in the acceptable range, replace the sensor cable.
<b>Current, frequency, pulse or PWM outputs do not match the readings</b>	<b>Incorrect parameter settings Wiring configuration issues Control system configuration issues</b>	Refer to Output Configuration for parameter settings.
		Check that the ID parameter for the output matches the parameter of the desired reading
		Verify that the minimum and maximum parameters for the output are set properly
		Verify the device reading the output is set up correctly. The current and frequency outputs have a test output ( <i>TstOut</i> ) that can be used to troubleshoot system issues.

Table 13: Troubleshooting symptoms/resolution

# PART NUMBER CONSTRUCTION

## Sensors 005 and 008 ONLY

<b>Model</b>	Badger Meter Coriolis Flow Meter	RCS					
<b>Nominal Line and Equivalent Pipe Size</b>	1/4 in., 1/16 in.	005					
	1/4 in., 3/32 in.	008					
<b>Wetted Material</b>	316L Stainless Steel	S					
<b>Process Connection Type</b>	NPT		NPT				
	O-Ring, Face Sealing Body, 9/16-18 Threads		FSM				
	O-Ring, Face Sealing Gland		FSF				
<b>Electronic Mounting Options</b>	Remote Mount Transmitter			R			
<b>Certifications</b>	General/Ordinary Area				G		
<b>Calibration/Meter Uncertainty</b>	Liquids (Gases)						
	Mass Flow: 0.1% (0.5%) ± 0.05% of FS zero stability; Density: ± 0.002 g/cm <sup>3</sup>					3	
<b>Reserved</b>	None (Reserved)						N
<b>Specials</b>	Special Code (leave blank for non-custom orders)						XXX

## Sensor Part Number (Remote Mount Transmitter Option)

<b>Model</b>	Badger Meter Coriolis Flow Meter	RCS					
<b>Nominal Line and Equivalent Pipe Size</b>	1/2 in., 3/16 in. (4.76 mm)	018					
	1/2 in., 1/4 in. (6.35 mm)	025					
	1/2 in., 1/2 in. (12.70 mm)	050					
	1 in., 1 in. (25.40 mm)	100					
	2 in., 2 in. (50.80 mm)	200					
	3 in., 3 in. (76.20 mm)	300					
<b>Wetted Material</b>	316L Stainless Steel	S					
<b>Process Connection Type</b>	NPT (018...200 sensors only)		NPT				
	150 lb ASME B16.5 Flange (018...300 sensors only)		FAA				
	300 lb ASME B16.5 Flange (018...300 sensors only)		FAB				
	PN40 Flange		PNB				
	Tri-clamp		TRI				
<b>Electronic Mounting Options</b>	Remote Mount Transmitter			R			
<b>Certifications</b>	General/Ordinary Area				G		
	CSA Class I, Div 1; Class I, Zone 0				H		
	ATEX I.S. Zone 0 sensor				A		
	IECEX I.S. Zone 0 sensor				C		
<b>Calibration/Meter Uncertainty</b>	Liquids						
	Mass Flow: 0.1% of reading ± 0.025% of full scale (100, 200, 300 sensors only)					1	
	Mass Flow: 0.2% of reading ± 0.05% of full scale (018...050 sensors only)					2	
	Mass Flow: 0.1% of reading					6	
<b>Reserved</b>	None (Reserved)						N

\*Other process connection types can be provided. Consult factory for pricing and delivery estimates.

### General Safety Transmitter Part Number (Remote Mount)



**Communication Protocol**

- Modbus RTU & Ethernet (Modbus TCP/IP, EtherNet/IP)
- Modbus RTU (Standard on all models)

E  
M

**Sensor Connection**

- Ordinary Areas (RCTN only)

N

### Hazardous Location Transmitter Part Number (Remote Mount)



**Certifications**

- CSA Class I, Div 1; Class I Zone 1
- ATEX I.S. Zone 1
- IECEx I.S. Zone 1

H1  
A1  
C1

**Communication Protocol**

- Modbus RTU & Ethernet (Modbus TCP/IP, EtherNet/IP)
- Modbus RTU (Standard on all models)
- Modbus RTU & HART

E  
M  
H

**Sensor Connection**

- Hazardous location (RCTX only)

B

### Integral Mount Transmitter with Sensor Part Number Construction

	1	2	3	4	5	6	7	8	9	10
<b>Model</b>	RCS									
<b>Nominal Line Size and Flow Rate</b>										
1/2 Inch / DN15   20 lb/min	018									
1/2 Inch / DN15   40 lb/min	025									
1/2 Inch / DN15   220 lb/min	050									
1 Inch / DN25   1000 lb/min	100									
2 Inch / DN50   1700 lb/min	200									
3 Inch / DN80   5200 lb/min	300									
<b>Wetted Material</b>	S									
<b>Process Connection Type *</b>										
National Pipe Thread (018...200 sensors)					NPT					
150 lb ANSI Flange (018...300 sensors)					FAA					
300 lb ANSI Flange (018...300 sensors)					FAB					
PN40 Flange					PNB					
Tri-clamp					TRI					
<b>Electronic Mounting Options</b>	M									
Integral Mount Transmitter (with RCTX only)										
<b>Certifications</b>										
CSA Class I, Div 1; Class I, Zone 1									H	
ATEX I.S. Zone 1									A	
IECEX I.S. Zone 1									C	
<b>Calibration/Meter Uncertainty</b>										
<b>Liquids</b>										
(018...050 sensors) Mass Flow: 0.2% of reading ± 0.05% of full scale										2
(100...300 sensors) Mass Flow: 0.1% of reading ± 0.025% of full scale										1
Mass Flow: 0.1% of reading										6
<b>Reserved</b>	N									
None (Reserved)										
<b>Display</b>										
Explosion Proof Transmitter, Display / Keypad										XK
Explosion Proof Transmitter, No Display / Keypad										XN
<b>Communication</b>										
Modbus RTU & Ethernet (Modbus TCP/IP, EtherNet/IP)										E
Modbus RTU (Standard on all models)										M
Modbus RTU and HART										H

\*Other process connection types can be provided. Consult factory for pricing and delivery estimates.

## SPECIFICATIONS

### System with RCS005/RCS008 Sensors

<b>Uncertainty</b>	Mass Flow Rate (Liquids)	RCS005	± 0.1% for flow rate > 0.05 lb/min ± 0.00005 lb/min for flow rate ≤ 0.05 lb/min
		RCS008	± 0.1% for flow rate > 0.2 lb/min ± 0.0002 lb/min for flow rate ≤ 0.2 lb/min
<b>Density</b>	±0.12486 lb/ft <sup>3</sup> (0.002 g/cm <sup>3</sup> )		
<b>Repeatability</b>	±0.05% of reading ± zero stability		
<b>Zero Stability</b>	RCS005	±0.00005 lb/min	
	RCS008	± 0.0002 lb/min	
<b>Safety Certifications</b>	Ordinary Location	UL61010-1/CSA C22.2 No. 61010-1:2010	
<b>Density Measurement</b>	Flowing, referenced, API, Brix, Baume and net oil		
<b>Conformance</b>	CE		

### Flow Rate Specifications

Model	Nominal Line and Equivalent Pipe Size	Number of Flow Tubes	Flow Range		Volumetric Equivalent 1 g/cm <sup>3</sup>	
			lb/min	kg/hr	gal/min	l/h
RCS005	1/4 in., 1/16 in.	1	0...1.25	0...34	0.124	34
RCS008	1/4 in., 3/32 in.	1	0...2.75	0...74.8	0.274	74.8

### RCS005/RCS008 Sensors Specifications

<b>Pressure</b>	<b>Model</b>	<b>Maximum Allowable Pressure</b>
	RCS005	2755 psi (190 bar)
	RCS008	1800 psi (124 bar)
<b>Wetted Materials</b>	<b>Standard</b>	316L stainless steel
<b>Temperature</b>	<b>Fluid Range</b>	-40...392° F (-40...200° C)
	<b>Accuracy</b>	±1.8° F (1° C)
	<b>Repeatability</b>	±0.54° F (0.3° C)
<b>Process Connections</b>	1/4 in. O-ring face sealing	
<b>Conformance</b>	ASME B31.3 Pressure Piping Hydro Test NACE MR0175/ISO 15156	

The complete remote mount metering system consists of the following; each component must be purchased separately:

- Sensor
- Transmitter
- Cable assembly

### System Specifications

<b>Uncertainty</b>	Mass Flow Rate (Liquids)	RCS018, RCS025, RCS050 (option 2)	±0.2% of reading ±0.05% of full scale	
		RCS100, RCS200, RCS300 (option 1)	±0.1% of reading ±0.025% of full scale	
		RCS018...300 (option 6)	±0.1% of reading*	
<b>Density</b>	RCS018, RCS025, RCS050	±0.12486 lb/ft <sup>3</sup> (0.002 g/cm <sup>3</sup> )		
	RCS100, RCS200, RCS300	±0.03121 lb/ft <sup>3</sup> (0.0005 g/cm <sup>3</sup> )		
<b>Repeatability</b>	RCS018, RCS025, RCS050, RCS100, RCS200, RCS300	±0.05% of reading ± zero stability		
<b>Zero Stability</b>	RCS018, RCS025, RCS050	±0.05% of full scale		
	RCS100, RCS200, RCS300 (option 1)	±0.025% of full scale		
	RCS100 (option 6)	±0.123 lb/min (3.35 kg/hr)		
	RCS200 (option 6)	±0.360 lb/min (9.79 kg/hr)		
	RCS300 (option 6)	±0.356 lb/min (9.68 kg/hr)		
<b>Safety Certifications</b>	cCSAus	Ordinary Location	Remote mount	CAN/CSA C22.2 No. 61010-1-12
		Integral mount	CI I, Zn 1 AEx/Ex db ia IIB T4 Gb Explosion-proof for CI I Div 1 Grp CD with Intrinsically Safe Sensor for CI I Div 1 Grp CD	
		Remote transmitter	CI I, Zn 1 AEx/Ex db [ia Ga] IIB T6...T3 Gb Explosion-proof for CI I Div 1 Grp CD	
		Remote sensor	CI I, Zn 0 AEx/Ex ia IIB T6...T3 Ga Intrinsically Safe for CI I Div 1 Grp CD	
	ATEX / IECEx	Integral mount	II 2 G Ex db ia IIB T4 Gb	
		Remote transmitter	II 2 (1) G Ex db [ia Ga] IIB T6...T3 Gb	
		Remote sensor	II 1 G Ex ia IIB T6...T3 Ga	
<b>Density Measurement</b>	Flowing, referenced, API, Brix, Baume and net oil			

\* When flow rate is less than zero stability (lb/min) \* 1000, accuracy = zero stability / flow rate.

### Flow Rate Specifications

Model	Nominal Line and Equivalent Pipe Size	Number of Flow Tubes	Flow Range		Volumetric Equivalent 1g/cm <sup>3</sup>	
			lb/min	kg/hr	gal/min	l/h
RCS018	1/2 in., 3/16 in.	2	0...20	0...544	2.4	544
RCS025	1/2 in., 1/4 in.	2	0...40	0...1088	4.8	1088
RCS050	1/2 in., 1/2 in.	2	0...220	0...5987	26	5987
RCS100	1 in.	2	0...1000	0...27,216	120	27,716
RCS200	2 in.	2	0...1700	0...46,266	204	46,266
RCS300	3 in.	2	0...5200	0...141,520	623	141,520

### Sensor Specifications

	Model	Maximum Allowable Pressure (by Connection Type)				
		NPT	Class 150 Flange	Class 300 Flange	DN PN40	Tri-Clamp
<b>Pressure</b>	RCS018	3450 psi (238 bar)	275 psi (19 bar)	720 psi (49.6 bar)	40 bar (580 psi)	200 psi (14 bar)
	RCS025	3450 psi (238 bar)	275 psi (19 bar)	720 psi (49.6 bar)	40 bar (580 psi)	200 psi (14 bar)
	RCS050	3320 psi (229 bar)	275 psi (19 bar)	720 psi (49.6 bar)	40 bar (580 psi)	200 psi (14 bar)
	RCS100	2150 psi (148 bar)	275 psi (19 bar)	720 psi (49.6 bar)	40 bar (580 psi)	200 psi (14 bar)
	RCS200	2200 psi (152 bar)	275 psi (19 bar)	720 psi (49.6 bar)	40 bar (580 psi)	200 psi (14 bar)
	RCS300	—	275 psi (19 bar)	720 psi (49.6 bar)	40 bar (580 psi)	200 psi (14 bar)
<b>Wetted Materials</b>	Standard	316L stainless steel				
<b>Temperature</b>	Fluid Range	General Safety: -40...392° F (-40...200° C) Hazardous Location Sensor with Integral Mount Transmitter: -4...140° F (-20...60° C) Hazardous Location Sensor with Remote Mount Transmitter: -4...359° F (-20...182° C) as follows:				
		TEMP CODE	FLUID TEMP (MAX)			
		T6 (85° C)	67° C			
		T5 (100° C)	82° C			
	T4 (135° C)	117° C				
	T3 (200° C)	182° C				
	Accuracy	±1.8° F (1° C)				
	Repeatability	±0.54° F (0.3° C)				
<b>Process Connections</b>	NPT (RCS018...200), Class 150 Flange, Class 300 Flange, DN PN40, Tri-Clamp					
<b>Conformance</b>	NACE MR0175/ISO 15156					





## Transmitters

Feature		Model		
		RCTN	RCTX	RCTX with Display
<b>Enclosure</b>		NEMA 4 (IP65); powder coated aluminum, polycarbonate, urethane and stainless steel	NEMA 4X (IP66); powder coated aluminum, polycarbonate, urethane and stainless steel without glass window	NEMA 4X (IP66); powder coated aluminum, polycarbonate, urethane and stainless steel with glass window
<b>Power Requirements</b>		115/230V AC; $\pm 15\%$ 50/60 Hz 25W maximum 20...28V DC; 15W maximum	— 18...28V DC; 15W maximum	—
<b>Ambient Temperature</b>		14...158° F (–10...70° C)	– 4...140° F (–20...60° C)	– 4...140° F (–20...60° C)
<b>Configuration</b>		Four-button HMI or RCT Console configuration	RCT Console configuration	Four-Optical button HMI or RCT Console configuration
<b>Display</b>		4 line $\times$ 20 character; alpha-numeric; dot matrix; LED backlighting	—	4 line $\times$ 20 character; alpha-numeric; dot matrix; LED backlighting
<b>RTD Input</b>	<b>Standard (1 input)</b>	Built-in 100 Ohm Platinum RTD within the sensor body		
	<b>Optional (1 auxiliary input)</b>	Additional 100 Ohm 3-wire Platinum RTD input for the secondary RTD is used by customers who want to be able to calibrate their RTD	—	—
<b>Analog I/O</b>	<b>Outputs</b>	Three 4...20 mA (0...22 mA capable), maximum load 500 Ohms, approximately 16 bit resolution outputs; assignable to mass flow, volume, density, temperature, concentration, PID and similar measurements. User defined fault condition output value anywhere in the 0...22 mA range	Two (three with HART Option) 4...20 mA (0...22 mA capable), maximum load 500 Ohms, approximately 16 bit resolution outputs; assignable to mass flow, volume, density, temperature, concentration, PID and similar measurements. User defined fault condition output value anywhere in the 0...22 mA range	
	<b>Inputs</b>	Two 0...5V DC inputs. 20k Ohms input impedance, approximately 12 bit resolution	One 0...5V DC input. 20k Ohms input impedance, approximately 12 bit resolution	
<b>Auxiliary Power</b>		Internal 24V DC supply, 100 mA max. (for batching functions, frequency output channel and like applications)	—	—
<b>Frequency/Pulse Output</b>		One open collector transistor, user configurable as rate (3 kHz max output), accumulator 0...10 Hz; PWM with 1 kHz, 5...28V DC carrier. User assignable to rate, any totalizer, PID, temperature, density, concentration or other similar measurements		
<b>Digital I/O</b>	<b>Outputs</b>	Four 5...28V DC, 50 mA maximum current draw (external pullup resistor required)	Two 5...28V DC, 50 mA maximum current draw (external pullup resistor required)	
	<b>Inputs</b>	Four 5...24V DC, 1k Ohms impedance	Three 5...24V DC, 1k Ohm impedance	
<b>Industrial Communications Modular Port</b>	<b>Standard</b>	Modbus RTU (EIA-485/RS485)		
	<b>Optional Module</b>	Modbus TCP/IP & EtherNet/IP		
	<b>Optional Module</b>	—	HART 7	
<b>Standard Configuration Port</b>		USB 2.0 interface (through a Mini-B receptacle) for RCT Console software		
<b>Alarms</b>		Six Hi/Lo Alarms; Alarm status on display by default, assignable to digital Output 2 or 4 and available via digital communications	Six Hi/Lo Alarms; Alarm status on display by default, assignable to digital Output 2 and available via digital communications	
<b>Transmission Distance</b>		Up to 100 ft (30 meters); contact factory if longer length is needed		
<b>Measurements</b>		Forward and reverse mass flow and total, density, temperature; concentration, volumetric flow and total (derived)		
<b>Other Functions</b>		Batch control, PID control. User configuration of all I/O functions		

## CABLE KITS

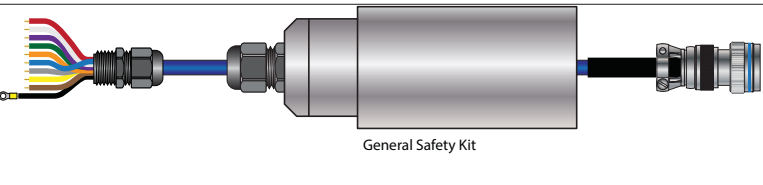
The kits include the cable assembly, cable protector and sensor cable connection cover.

<b>RC820476-XX</b>	Kit, PVC jacketed cable <b>XX</b> =length in ft; 20, 35, 50, 70, 100	Temp range: -40...176° F (-40...80° C)	 <p style="text-align: center;">General Safety Kit</p>
<b>RC820477-XX</b>	Kit, FEP jacketed cable <b>XX</b> =length in ft; 20, 35, 50, 70, 100	Temp range: -94...392° F (-70...200° C)	
<b>RC830054-XX</b>	TFE jacketed cable <b>XX</b> =length in ft; 20, 35, 50, 70, 100	Temp range: -4...140° F (-20...60° C)	 <p style="text-align: center;">Hazardous Location Cable</p>

## PARAMETERS BY ADDRESS (ADDR)

Addr	Symbol	Data Type	Parameter Name	Parameter Description
0	SDate	String	Software Date	Date of transmitter software
1	ComAdd	Byte	Comm Address	Communication address
2	BaudRate	Float	Baud Rate	Baud rate of transmitter
3	FWV	String	Software Version	Version number of transmitter firmware
4	SMT	String	Sensor Type	Type of installed sensor
5	Ntwk#	String	Transmitter Serial	Serial number of transmitter
6	Sen#	String	Sensor Serial	Serial number of sensor
7	Reset	Byte	Reset Transmitter	Resets transmitter
9	Contrast	Float	Display Contrast	Sets contrast of display
10	strtB	Byte	Start Bits	State of start bits
11	Status	Byte	Status Bits	State of status bits
12	StopB	Byte	Stop Bits	State of stop bits
13	AlmStat	Byte	Error Record	(Error record)
14	InSts	Byte	Status Inputs	State of status input bits
15	OutSts	Byte	Status Outputs	State of status output bits
16	SenSze	Byte	Sensor Size	List of available sensors
17	Key	Byte	Keyboard Code	Code of last pressed key
20	Zero	Float	Meter Zero	Measured phase when no flow
21	—	Byte	Start Zero Calibration	Starts zero calibration
22	—	Byte	Stop Zero Calibration	Stops zero calibration
23	ZroAvg	Float	Average Meter Zero	Average phase during zeroing
24	SenWL	Float	Sensor Warning Limit	Sensor level warning limit
25	ZroRng	Float	Meter Zero Range	Zero range during zero calibration
26	ZroTFac	Float	Meter Zero Temperature Correction	Temperature correction of meter zero value
28	ZroCntr	Byte	Zero Calibration Counter	Progress counter of zero calibration
29	ZroL	Float	Zero Calibration Start Limit	Flow rate must be less than this percentage of full scale to start zero calibration
30	IPhase	Float	Raw Phase	Unfiltered phase difference
31	TotWCnt	Unsigned Integer	Totalizer Wrap Count	Counts how many times the totalizer has been wrapped around
32	BatSus	Byte	Suspend Batch	Suspends batching while = 1
33	Phase	Float	Phase	Filtered phase difference
35	PhsCrt	String	Critical Phase	Critical phase
36	PhsSlp	Float	Critical Phase Slope	Critical phase slope
37	MnuApp	Byte	Application Menu Control	Turns ON or OFF the application menu
38	SenMat	Byte	Sensor Material	Material the sensor is made of
39	DTCrt	Float	Density Correction Temperature	Temperature coefficient for normalizing frequency dependence on temperature
40	PhsFil	Byte	Phase Filter	Length of the phase filtering ring buffer
41	CPUcrt	Float	CPU Frequency Correction	Correction factor to normalize CPU clock error
42	ERHist	Error Record	Error History	Error history record of transmitter
43	+RFlow	Byte	Enable Reverse Flow	Enables/disables the reverse flow calculation
44	PhsNor	Float	Phase Correction	Phase normalization
45	IFlow	Float	Raw Mass Flow Rate	Non-filtered mass flow rate
46	FloFct	Float	Flow Factor	Mass flow factor
47	MxFlo	Float	Maximum Mass Flow Rate	Nominal maximum mass flow rate anticipated in the meter
48	MnFlo	Float	Zero Mass Flow Limit	If the mass flow rate less than this limit, the flow will read as zero
49	mTFct	Float	Mass Flow Temperature Factor	Compensation factor of mass flow rate
50	mLinFct	Float	Mass Flow Linearization Factor	Linearization factor of the mass flow rate
51	RTD1Of	Float	RTD1 Linearization Offset	Offset linearization factor of the Pt-100 sensor
52	RTD1Sl	Float	RTD1 Linearization Slope	Slope linearization factor of the Pt-100 sensor
53	DCrt	Float	Density Correction Factor	Density correction factor of mass flow
54	mDmp	Byte	Mass Flow Dampening	Filter number for mass flow rate
55	RemFlo	Float	Reverse Mass Flow Rate	Reverse mass flow rate (not implemented yet)

Addr	Symbol	Data Type	Parameter Name	Parameter Description
56	NetFlo	Float	Net Mass Flow Rate	Net mass flow rate
57	NetVFlo	Float	Net Volumetric Flow Rate	Net volumetric flow rate
58	%mFlo	Float	Percentage Mass Flow	Mass flow in percentage of maximum mass flow rate
59	mFlo	Float	Mass Flow Rate	Filtered mass flow rate
60	Freq	Float	Tube Frequency	Vibration frequency of sensor tubes
61	CycT	Float	Cycle Time of Main CPU	Cycle time of main CPU
62	MnFreq	Float	Minimum Tube Frequency	Minimum vibration frequency of sensor tubes
63	MxFreq	Float	Maximum Tube Frequency	Maximum vibration frequency of sensor tubes
64	Zrom	Float	Meter Zero in Mass Flow Rate	Meter zero of the sensor expressed in mass flow units
65	Temp1	Float	Temperature #1	Temperature RTD 1
66	TBase	Float	Base Temperature	Base temperature for corrections
67	MnTemp	Float	Minimum Temperature	Minimum temperature scaling point
68	MxTemp	Float	Maximum Temperature	Maximum temperature scaling point
69	TempDmp	Float	Temperature Dampening	Filter number for temperature
70	Dens	Float	Density	Process density
71	SG	Float	Specific Gravity	Process density / specific gravity factor
72	DAlpha	Float	Density Alpha	Density alpha linearization factor
73	DBeta	Float	Density Beta	Density beta linearization factor
74	SGFct	Float	Specific Gravity Factor	Specific gravity calculation factor
75	DKTFct	Float	Density KT Factor	Density KT factor
76	DDWt	Float	Density DW Factor	Density DW calculation reference temperature
77	DDmp	Float	Density Dampening	Filter number for density
78	DMode	Float	Density Mode	Controls density calculation mode
79	MnuConc	Byte	Concentration Menu	Shows / hides concentration menu
80	mTot	Float	Mass Totalizer	Resettable mass totalizer
81	—	Byte	Reset Mass Totalizer	Resets all resettable mass totalizers except overall mass total
82	AllTot	Float	Overall Mass Totalizer	Non-resettable mass totalizer
83	mTotWL	Float	Mass Totalizer Wrap Limit	Wrap limit of mass totalizers
84	RemTot	Float	Remote Mass Totalizer	Contains mass totalizer (80) value read from remote transmitter via serial line
85	NetmTot	Float	Net Mass Totalizer	Difference (or sum) of the totalizers for two interconnected meters
86	NFloM	Byte	Net Flow Mode	Mode of net flow calculation
87	MnuNet	Byte	Net Flow Menu	Shows / hides net flow menu
88	MnuTot	Byte	Totalizer Menu	Shows / hides totalizer menu
89	MnuAlarm	Byte	Alarm Menu	Shows / hides alarm menu
90	BTot	Float	Batch Totalizer	Mass total during batching
91	—	Byte	Start Batch	Starts batching
92	—	Byte	Stop Batch	Cancels batching
93	BSpt	Float	Batch Setpoint	Desired size of batching
94	BMode	Byte	Batch Mode	Determines the flow parameter used during batching
95	BTPrT	Float	Batch Timing Pre-Trigger	Trigger the opto drivers at a certain time before the batch would otherwise stop
96	BQPrt	Float	Batch Quantity Pre-Trigger	Trigger the opto drivers at a certain amount before the batch would otherwise stop
97	BPrst	Float	Batch Preset	Turns off the batch relays early by this amount (the amount anticipated to dribble after the batch relays close)
98	BSpErr	Byte	Batch Stop on Error	Stops batch if error or alarm warnings happen
99	BType	Byte	Batch Type	Controls type of batching
100	vFlo	Float	Volumetric Flow Rate	Calculated by dividing mass flow rate by density
101	vTot	Float	Volumetric Total	Resettable volumetric totalizer
102	RemVTot	Float	Reverse Volumetric Total	Reverse volumetric totalizer
103	NetVTot	Float	Net Volumetric Total	Net volumetric totalizer
104	mFloA	Float	Mass Flow Rate A	Mass flow rate of component A
105	mFloB	Float	Mass Flow Rate B	Mass flow rate of component B
106	mTotA	Float	Mass Totalizer A	Mass totalizer of component A
107	mTotB	Float	Mass Totalizer B	Mass totalizer of component B

Addr	Symbol	Data Type	Parameter Name	Parameter Description
108	m%A	Float	Mass Percentage A	Mass percentage of component A
109	m%B	Float	Mass Percentage B	Mass percentage of component B
110	CompAD	Float	Density of Component A	Density of component A
111	CompBD	Float	Density of Component B	Density of component B
112	BxMode	Byte	Brix Mode	Soluble or insoluble switch
113	A1	Float	Brix A1	Brix A1 coefficient
114	A2	Float	Brix A2	Brix A2 coefficient
115	A3	Float	Brix A3	Brix A3 coefficient
116	B1	Float	Brix B1	Brix B1 coefficient
117	B2	Float	Brix B2	Brix B2 coefficient
118	B3	Float	Brix B3	Brix B3 coefficient
119	SlugFlo	Float	Slug in Flow	Freezes mass flow rate at last reading where the flow rate was stable
120	IOut1	Float	Current #1 Output	Actual current on Current #1 output
121	IOut2	Float	Current#2 Output	Actual current on Current #2 output
122	FrqOut	Float	Frequency #1 Output	Actual frequency on Frequency output port
123	—	Record	Current#1 Output Setup	Controls Current #1 output
124	—	Record	Current#2 Output Setup	Controls Current #2 output
125	—	Record	Frequency #1 Output Setup	Controls the Frequency output setup
126	+AltI1	Byte	Enable Alternate Current #1	Enables alternate current on Current #1 output
127	+AltI2	Byte	Enable Alternate Current #2	Enables alternate current on Current #2 output
128	+AltFrq	Byte	Enable Alternate Frequency #1	Enables alternate frequency and PWM on Frequency #1 output
129	FrqOEN	Byte	Enable Frequency #1 Output	Enables Frequency #1 output
130	PlsOM	Byte	Pulse Output Mode	Selects the frequency, pulse, or pulse width modulation mode on Frequency #1 output
131	PlsID	Byte	Pulse Output Item	ID of item attached to pulse output
132	PlsSze	Float	Pulse Size	Size of increment after which a pulse is generated
133	PlsWth	Unsigned Integer	Pulse width	Width of pulse in ms
134	C3	Float	Brix C3	Brix C3 coefficient
135	Anin2	Float	Analog Input #2	Voltage measured on Analog Input #2
136	Temp2	float	Temperature #2	Temperature of RTD2
137	AlarmRec	Record	Alarm Setup	Controls transmitter alarms
138	MnuBatch	Byte	Batch Menu	Shows / hides batch menu
140	PWLvl	Byte	Password Level	Currently set password level in transmitter
141	PWRef	Record	Reference Passwords	Reference passwords in transmitter
142	PWSet	Unsigned Integer	User Password	Password entered by user
150	PIDEN	Byte	PID Controller	Enables / disables PID controller
151	PSpt	Float	PID Setpoint	Desired value to keep constant
152	POUT	Float	PID Output	Output percentage of PID controller
153	SamTim	Unsigned Integer	PID Sampling Time	PID controller runs in every sampling time ms
154	PGn	Float	PID Gain	Gain of the PID controller: $C_g * (CS - X)$
155	PDer	Float	PID Derivation Factor	Derivation factor of the PID controller: $C_d * (Error - Error^1)$
156	Plnt	Float	PID Integrating Factor	Integrating factor of the PID controller: $C_i * SUM(Error)$
157	POfset	Float	PID Offset	This value is always added to the PID output
158	MnuPID	Byte	PID Menu	Shows / hides the PID menu
159	PIDID	Byte	PID Assigned To Item	PID controller is assigned to this parameter
170	ChkSum	Unsigned Integer	Check Sum of Program	Check sum of program
172	Wl2	Float	W2 Work Item	W2 floating point variable for APP programs
173	IDB	Byte	APP Enable Bits	APP enable bits
174	WBit	Byte	Wb Work Bit	Wb bit type variable for APP programs
175	Wl1	Float	W1 Work Item	W1 floating point variable for APP programs
176	API	String	API	API gravity
177	Baume	String	Degrees Baume	Degrees Baume

Addr	Symbol	Data Type	Parameter Name	Parameter Description
180	ISOC	Byte	Isolated Current Output Control	Isolated current output control
181	C1	Float	Brix C1	Brix C1 coefficient
182	C2	Float	Brix C2	Brix C2 coefficient
183	CoilA	Float	Coil A Voltage	Voltage of sensor coil A
184	DrvOut	Float	Driver Output	Driver voltage value in %
185	CoilB	Float	Coil B Voltage	Voltage of sensor coil B
186	DrvGn	Float	Driver Gain	PID Gain for driver control
187	DrvDe	Float	Driver Derivation Factor	Derivation factor of the PID driver control
188	DrvInt	Float	Driver Integrating Factor	Integrating factor of the PID driver control
189	DrvAs	Byte	Driver Source	Selects the input source of driver
190	DrvSP	Float	Driver Setpoint	Desired voltage on sensor reference coil (default is A)
191	DrvRat	Float	Secondary Driver Ratio	Voltage ratio between driver A and driver B
192	DrvAM	Byte	Driver A Mode	Determines the source signal for driver A
193	DrvBM	Byte	Driver B Mode	Determines the source signal for driver B
194	HmrM	Byte	Hammer Mode	Controls the way how we can help the tubes start vibrating
195	BP1	Float	Batch Preset 1	Desired size of batching
196	BP2	Float	Batch Preset 2	Desired size of batching
197	BP3	Float	Batch Preset 3	Desired size of batching
198	BP4	Float	Batch Preset 4	Desired size of batching
199	BP5	Float	Batch Preset 5	Desired size of batching
200	BP6	Float	Batch Preset 6	Desired size of batching
201	ComPr1	Byte	COM1 Protocol	Communication protocol used on COM1 port
202	HARTAdd	Unsigned Integer	Polling Address	Polling address for HART protocol
216	Time	String	Time	Time of day in hh:mm:ss format
217	Date	String	Date	Current date in mm:dd:yy format
223	Tag	String	Tag	Optional tag info of transmitter
224	Name	String	Descriptor	Optional descriptor of transmitter
225	Act#	String	Account Number	Account number
226	Anin1	Float	Analog Input #1	Voltage measured on Analog Input #1
227	An1SI	Float	Analog 1 Slope	Slope for analog 1 input calculation
228	An1Of	Float	Analog 1 Offset	Offset for analog 1 input calculation
229	IOut3	Float	Current #3 Output	Actual current on Current #3 output
230	—	Record	Current #3 Output Setup	Controls Current #3 output
231	+AltI3	Byte	Enable Alternate Current #3	Enables alternate current on Current #3 output
232	An2SI	Float	Analog 2 Slope	Slope for analog 2 input calculation
233	An2Of	Float	Analog 2 Offset	Offset for analog 2 input calculation
234	RTD2Of	Float	RTD2 Linearization Offset	Offset linearization factor of the Pt-100 sensor
235	RTD2SI	Float	RTD2 Linearization Slope	Slope linearization factor of the Pt-100 sensor
236	DspTpe	Byte	Display Type	Type of LCD module used
237	CoilAv	Float	Average Coil Voltage	Average coil of sensor coil A and B
239	FMTot	Float	Mass Totalizer Forward	Forward mass totalizer
240	RMTot	Float	Mass Totalizer Reverse	Reverse mass totalizer
241	Relay	Byte	Batch Relay	Enables / disables batch relay outputs (opto 1-4)
242	WI3	Float	W3 Work Item (P)	Floating point variable for APP programs
243	WI4	Float	W4 Work Item (d)	Floating point variable for APP programs
244	StdVol	String	Volume under standard conditions	Volume under standard conditions
245	StdvFlow	String	Volumetric flow rate referred to standard conditions	Volumetric flow rate referred to standard conditions
246	AnDmp	Byte	Analog Inputs Dampening	Filter number for analog inputs
247	NorFrq	Float	Normalized Tube Frequency	Normalized vibration frequency of sensor tubes
248	WI7	Float	W7 Work Item (v)	Floating point variable for APP programs
249	WI8	Float	W8 Work Item (dv)	Floating point variable for APP programs
250	WI9	Float	W9 Work Item (kv)	Floating point variable for APP programs
253	PWMFrq	Byte	PWM Carrier	Period time of PWM carrier frequency
254	PWMO	Float	Alternate PWM	Simulated pulse width if 128 (Enable Alternate Frequency) is enabled
256	BTime	Float	Batch Time	Batch run time



Addr	Symbol	Data Type	Parameter Name	Parameter Description
258	FrqDmp	Byte	Tube Frequency Filter	Filter number for tube frequency
259	PHold	Unsigned Integer	PID Hold	Hold state of the PID controller
260	ComPr2	Byte	COM2 Protocol	Communication protocol used on COM2 port
272	PhsMsrA	Float	Included Total Area	Included total area code sum
273	AFAcPhs	Float	Area-to-Phase Conversion Factor	Converts included total area to phase
274	PhsMsr	Unsigned Integer	ADC Sample Count	Count of ADC samples in a full IF CPU cycle
275	BackUp#	Unsigned Integer	Count of Flash Backups	Count of flash backups
276	Restore#	Unsigned Integer	Count of Flash Restores	Count of flash restores
277	BackUp	Byte	Backup Transmitter	Makes backups of main variables to flash memory
278	FlsRes	Byte	Restore Transmitter	Restores main variables from flash memory backup
279	FlshClr	Byte	Clear Transmitter Backup	Clears flash memory backup (Warning: All factory settings will be lost)
280	SenDmp	Byte	Coil Voltage Filter	0-99% coil voltage filtering
281	PhsBL	Byte	Included Total Area Filter	Length of included total area ring buffer
282	FiltA	Float	Filtered Included Total Area	Filtered included total area code sum
283	RTD1	Float	RTD1 Resistance	Calculated RTD1 resistance
284	RTD2	Float	RTD2 Resistance	Calculated RTD2 resistance
285	FWC	String	Name of Firmware	Shows implemented functions in firmware
286	APP	String	Name of APP Program	Shows implemented functions in application program
287	APSts	Byte	APP Program Status	Enables/disables app program. Cleared at next reset
288	BEst	Byte	Batch Estimation	Estimates the end of batch to minimize the batch counter overflow
289	CYM	N/A	Maximum Cycle Time of Main CPU	Maximum cycle time of main CPU
290	EAlmOut	Byte	Enable Alarm Output	Enables/disables alarm signal on OPTO#4 output
291	BFloAv	String	Average Flow Rate (Batch)	Average flow rate during batching
292	TPd	String	Ticket Printer Format	Ticket printer report definition
293	TPReq	Byte	Print Ticket	Starts printing ticket printer report
294	TPBaud	String	Ticket Printer Baud Rate	Baud rate of ticket printer
295	FlsChg#	String	Count of Changed Parameters	Count of changed parameters not backed up yet
296	UnitSys	Byte	Unit System	Unit system of transmitter
297	HamStrt	Float	Hammer Start Delay	Wait time before starting hammering
298	HamTime	Float	Hammer on Time	Time while the digital hammering is on
299	AppCtrl	Byte	App Program Control	Controls which APP program should be executed
300	Scroll	Byte	Scroll	Determines the menu scrolling direction
301	TxmType	Byte	Transmitter Type	Type of transmitter
302	PwExp	Unsigned Integer	Password Expiring Policy	Determines which password expires at midnight, per COM protocol basis
303	KbLock	Byte	Keyboard Lock Control	Enables / disables automatic keyboard lock after 1 minute of keyboard idle time
304	Lang	Byte	Display Language of Transmitter	Language of the user interface in the transmitter
554	BI	Byte	Batch Parent Item	Parent item of Batch Totalizer and Setpoint items
700	Param1	Byte	User Parameter #1	User parameter in HOME menu
701	Param2	Byte	User Parameter #2	User parameter in HOME menu
702	Param3	Byte	User Parameter #3	User parameter in HOME menu
703	Param4	Byte	User Parameter #4	User parameter in HOME menu
704	Param5	Byte	User Parameter #5	User parameter in HOME menu
705	Param6	Byte	User Parameter #6	User parameter in HOME menu
706	Param7	Byte	User Parameter #7	User parameter in HOME menu
707	Param8	Byte	User Parameter #8	User parameter in HOME menu

## PARAMETERS BY MENU LOCATION

Description of column headers in the following tables:

- Value = Write value or selection
- Unit / Decimal = Change units or number of digits after the decimal, if applicable

### Main Menu > Measurement

Parameter	Param. Addr	Description	Password Levels								
			Operator			Technician			Engineer		
			Read	Write		Read	Write		Read	Write	
				Value	Unit / Decimal		Value	Unit / Decimal		Value	Unit / Decimal
mFlo	59	Mass Flow Rate	X		X	X		X	X		X
%mFlo	58	Percent of Mass Flow Rate	X		X	X		X	X		X
mTot	80	Mass Totalizer	X		X	X		X	X		X
FMTot	239	Forward Mass Total	X		X	X		X	X		X
RMTot	240	Reverse Mass Total	X		X	X		X	X		X
RESET TOTALS	81	Reset Totalizers	X	—		X	—		X	—	
AllTot	82	Overall Mass Totalizer	X		X	X		X	X		X
Dens	70	Density	X		X	X		X	X		X
SG	71	Specific Gravity	X		X	X		X	X		X
Temp1	65	RTD1 Temperature	X		X	X		X	X		X
Temp2	136	RTD2 Temperature	X		X	X		X	X		X
vFlo	100	Volumetric Flow Rate	X		X	X		X	X		X
vTot	101	Volumetric Total	X		X	X		X	X		X

### Main Menu > System > Sensor

Parameter	Param. Addr	Description	Password Levels								
			Operator			Technician			Engineer		
			Read	Write		Read	Write		Read	Write	
				Value	Unit / Decimal		Value	Unit / Decimal		Value	Unit / Decimal
CoilA	183	Voltage on Sensor Coil A	X		X	X		X	X		X
CoilB	185	Voltage on Sensor Coil B	X		X	X		X	X		X
DrvOut	184	Voltage on Drive Coil	X		X	X		X	X		X
Phase	33	Phase Shift	X		X	X		X	X		X
Freq	60	Tube Frequency	X		X	X		X	X		X
Temp1	65	RTD1 Temperature	X		X	X		X	X		X
Temp2	136	RTD2 Temperature	X		X	X		X	X		X
NorFrq	247	Normalized Vibration Frequency of Sensor Tubes	X		X	X		X	X		X
CoilAv	237	Voltage Average of CoilA and CoilB	X		X	X		X	X		X
CPUT	270	Internal Temperature of Processor	X		X	X		X	X		X



## Main Menu &gt; System &gt; IO Stat

Parameter	Param. Addr	Description	Password Levels								
			Operator			Technician			Engineer		
			Read	Write		Read	Write		Read	Write	
				Value	Unit / Decimal		Value	Unit / Decimal		Value	Unit / Decimal
IOut1	120	Current Output on Current Output Channel 1	X		X	X		X	X		X
IOut2	121	Current Output on Current Output Channel 2	X		X	X		X	X		X
IOut3	229	Current Output on Current Output Channel 3	X		X	X		X	X		X
FrqOut	122	Frequency Output	X		X	X		X	X		X
AnIn1	226	Current Input on Current Input Channel 1	X		X	X		X	X		X
AnIn2	135	Current Input on Current Input Channel 2	X		X	X		X	X		X
InSts	14	In Status	X			X			X		
OutSts	15	Out Status	X			X			X		

## Main Menu &gt; System &gt; About

Parameter	Param. Addr	Description	Password Levels								
			Operator			Technician			Engineer		
			Read	Write		Read	Write		Read	Write	
				Value	Unit / Decimal		Value	Unit / Decimal		Value	Unit / Decimal
SDate	0	Date of Transmitter Software	X			X			X		
FWV	3	Firmware Version	X			X			X		
Restore#	276	Restore Count	X			X			X		
BackUp#	275	Backup Count	X			X			X		
FlsChg#	295	Count of Changed Parameters, Not Backed Up Yet	X			X			X		
Time	216	Time	X			X			X	X	X
Date	217	Date	X			X			X	X	X
Act#	225	Account Number	X			X	X	X	X	X	X
Name	224	Optional Descriptor of Transmitter	X			X	X	X	X	X	X
Tag	223	Optional Tag Info of Transmitter	X			X	X	X	X	X	X
Sen#	6	Sensor Serial Number	X			X			X	X	X
Ntwk#	5	Network Serial Number	X			X			X	X	X
SMT	4	Type of Installed Sensor	X			X			X	X	X
APP	286	Name of Installed Application Program(s)	X			X			X		
FWC	285	Shows Implemented Functions in Firmware	X			X			X		

## Main Menu &gt; Set Up &gt; Calibration &gt; Flow

Parameter	Param. Addr	Description	Password Levels								
			Operator			Technician			Engineer		
			Read	Write		Read	Write		Read	Write	
				Value	Unit / Decimal		Value	Unit / Decimal		Value	Unit / Decimal
FloFct	46	Flow Factor	X		X	X		X	X		X
PhsBL	281	Phase Buffer Length						X	X		
PhsFil	40	Phase Filter	X			X		X	X		
+RFlow	43	Enable Reverse Flow				X	—		X	—	
SlugFlo	119	Slug in Flow	X		X	X		X	X		X
DCrt	53	Density Correction Factor for Mass Flow	X		X	X		X	X		X
mDmp	54	Mass Flow Dampening	X			X	X		X	X	
mTFct	49	Mass Flow Temperature Factor	X		X	X		X	X		X
MnFlo	48	Mass Flow Cutoff	X		X	X		X	X		X
MxFlo	47	Maximum Mass Flow	X		X	X		X	X		X
TBase	66	Temperature Base	X		X	X		X	X		X
mLinFct	50	Mass Linearization Factor	X		X	X		X	X		X

## Main Menu &gt; Set Up &gt; Calibration &gt; Density

Parameter	Param. Addr	Description	Password Levels								
			Operator			Technician			Engineer		
			Read	Write		Read	Write		Read	Write	
				Value	Unit / Decimal		Value	Unit / Decimal		Value	Unit / Decimal
DAlpha	72	Density Alpha	X		X	X		X	X		X
DBeta	73	Density Beta	X		X	X		X	X		X
SGFct	74	Specific Gravity Factor	X		X	X		X	X		X
DDWt	76	Density DW Reference Temperature	X		X	X		X	X		X
DKTFct	75	Density KT Factor	X		X	X		X	X		X
DTCrt	39	Density Correction Temperature						X			
DDmp	77	Density Dampening	X			X	X		X		
DMode	78	Density Mode						X			

## Main Menu &gt; Set Up &gt; Calibration &gt; Temperature

Parameter	Param. Addr	Description	Password Levels								
			Operator			Technician			Engineer		
			Read	Write		Read	Write		Read	Write	
				Value	Unit / Decimal		Value	Unit / Decimal		Value	Unit / Decimal
Temp1	65	RTD1 Temperature	X		X	X		X	X		X
RTD1Of	51	RTD1 Offset	X		X	X		X	X		X
RTD1SI	52	RTD1 Slope	X		X	X		X	X		X
MnTemp	67	Minimum Temperature Range of RTD1	X		X	X		X	X		X
MxTemp	68	Maximum Temperature Range of RTD1	X		X	X		X	X		X
TempDmp	69	Temperature Dampening	X			X	X		X	X	
RTD2Of	234	RTD2 Offset	X		X	X		X	X		X
RTD2SI	235	RTD2 Slope	X		X	X		X	X		X
RTD1	283	RTD1 Resistance Value	X		X	X		X	X		X
RTD2	284	RTD Resistance Value	X		X	X		X	X		X

## Main Menu &gt; Set Up &gt; Calibration &gt; Driver

Parameter	Param. Addr	Description	Password Levels								
			Operator			Technician			Engineer		
			Read	Write		Read	Write		Read	Write	
				Value	Unit / Decimal		Value	Unit / Decimal		Value	Unit / Decimal
DrvGn	186	Driver Gain							X	X	X
DrvDe	187	Driver Derivation Factor							X	X	X
DrvInt	188	Driver Integrating Factor							X	X	X
DrvAs	189	Driver Source							X	—	
DrvSP	190	Driver Setpoint							X	X	X
DrvAM	192	Driver A Mode							X	—	
DrvBM	193	Driver B Mode							X	—	
HmrM	194	Hammer Mode							X	—	
SenDmp	280	Sensor Damping							X	X	
HamStrt	297	Hammer Start Delay	X			X			X		
HamTime	298	Hammer On Time	X			X			X		

## Main Menu &gt; Set Up &gt; Calibration &gt; Zero Calibration

Parameter	Param. Addr	Description	Password Levels								
			Operator			Technician			Engineer		
			Read	Write		Read	Write		Read	Write	
				Value	Unit / Decimal		Value	Unit / Decimal		Value	Unit / Decimal
Start Zero	21	Starts a Zero Calibration	X	—		X	—		X	—	
Stop Zero	22	Stops a Zero Calibration	X	—		X	—		X	—	
Zero	20	Measure Phase When No Flow is Present	X		X	X		X	X	X	X
Phase	33	Phase Shift	X		X	X		X	X		X
ZroCntr	28	Progress Counter of Zero Calibration	X			X			X		
Zrom	64	Meter Zero in Mass Flow Units	X		X	X		X	X	X	X
Temp1	65	RTD1 Temperature	X		X	X		X	X		X
Freq	60	Tube Frequency	X		X	X		X	X		X
ZroAvg	23	Standard Deviation of the Last Zero Process	X		X	X		X	X	X	X
SenWL	24	Sensor Warning Limit	X		X	X		X	X	X	X
ZroRng	25	Meter Zero Range	X		X	X		X	X	X	X
ZroTFac	26	Temperature Correction of Meter Zero Value							X	X	
ZroL	29	Zero Calibration Start Limit	X	X	X	X	X	X	X	X	X
PhsFil	40	Phase Filter	X			X			X		
PhsNor	44	Phase Normalization	X	X	X	X			X		X

## Main Menu &gt; Set Up &gt; Calibration &gt; Primary

Parameter	Param. Addr	Description	Password Levels								
			Operator			Technician			Engineer		
			Read	Write		Read	Write		Read	Write	
				Value	Unit / Decimal		Value	Unit / Decimal		Value	Unit / Decimal
SenSze	16	Sensor Size	X			X			X		
SenMat	38	Sensor Tube Material	X			X			X		
MnFreq	62	Minimum Allowable Frequency	X		X	X	X	X	X	X	X
MxFreq	63	Maximum Allowable Frequency	X		X	X	X	X	X	X	X
FrqDmp	258	Frequency Dampening	X			X	X		X	X	
BackUp	277	Backup Transmitter	X			X	—		X	—	

**Main Menu > Set Up > System IO > Current1 Setup**

Parameter	Param. Addr	Description	Password Levels								
			Operator			Technician			Engineer		
			Read	Write		Read	Write		Read	Write	
				Value	Unit / Decimal		Value	Unit / Decimal		Value	Unit / Decimal
IOut1	120	Current Output on Current Channel 1	X		X	X		X	X		X
ID	—	Parameter ID	X			X	—		X	—	
IValueMn	—	Current Value Associated with Minimum Flow	X		X	X	X	X	X	X	X
IvluMx	—	Current Value Associated with Maximum Flow	X		X	X	X	X	X	X	X
ValueMn	—	Parameter Value Associated with Minimum Flow	X		X	X	X	X	X	X	X
ValueMx	—	Parameter Value Associated with Maximum Flow	X		X	X	X	X	X	X	X
TstOut	—	Tests Current Channel 1 Output	X		X	X	X	X	X	X	X
+Alt1	126	Enables Alternate Current on Current Channel 1 Output	X			X	—		X	—	

**Main Menu > Set Up > System IO > Current2 Setup**

Parameter	Param. Addr	Description	Password Levels								
			Operator			Technician			Engineer		
			Read	Write		Read	Write		Read	Write	
				Value	Unit / Decimal		Value	Unit / Decimal		Value	Unit / Decimal
IOut2	121	Current Output on Current Channel 2	X		X	X		X	X		X
ID	—	Parameter ID	X			X	—		X	—	
IValueMn	—	Current Value Associated with Minimum Flow	X		X	X	X	X	X	X	X
IvluMx	—	Current Value Associated with Maximum Flow	X		X	X	X	X	X	X	X
ValueMn	—	Parameter Value Associated with Minimum Flow	X		X	X	X	X	X	X	X
ValueMx	—	Parameter Value Associated with Maximum Flow	X		X	X	X	X	X	X	X
TstOut	—	Tests Current Channel 2 Output	X		X	X	X	X	X	X	X
+Alt2	127	Enables Alternate Current on Current Channel 2 Output	X			X	—		X	—	

## Main Menu &gt; Set Up &gt; System IO &gt; Current3 Setup

Parameter	Param. Addr	Description	Password Levels								
			Operator			Technician			Engineer		
			Read	Write		Read	Write		Read	Write	
				Value	Unit / Decimal		Value	Unit / Decimal		Value	Unit / Decimal
IOut3	229	Current Output on Current Channel 3	X		X	X		X	X		X
ID	—	Parameter ID	X			X	—		X	—	
IValueMn	—	Current Value Associated with Minimum Flow	X		X	X	X	X	X	X	X
IvluMx	—	Current Value Associated with Maximum Flow	X		X	X	X	X	X	X	X
ValueMn	—	Parameter Value Associated with Minimum Flow	X		X	X	X	X	X	X	X
ValueMx	—	Parameter Value Associated with Maximum Flow	X		X	X	X	X	X	X	X
TstOut	—	Tests Current Channel 3 Output	X		X	X	X	X	X	X	X
+AltI3	—	Enables Alternate Current on Current Channel 3 Output	X			X	—		X	—	

## Main Menu &gt; Set Up &gt; System IO &gt; Frequency Setup

Parameter	Param. Addr	Description	Password Levels								
			Operator			Technician			Engineer		
			Read	Write		Read	Write		Read	Write	
				Value	Unit / Decimal		Value	Unit / Decimal		Value	Unit / Decimal
FrqOut	122	Frequency Output	X		X	X		X	X		X
FrqOEN	129	Enables Frequency 1 Output	X			X	—		X	—	
ID	—	Parameter ID for Frequency 1 Output	X			X	—		X	—	
FrqMn	—	Frequency Value Associated with Minimum Flow	X		X	X	X	X	X	X	X
FrqMx	—	Frequency Value Associated with Maximum Flow	X		X	X	X	X	X	X	X
ValueMn	—	Parameter Value Associated with Minimum Flow	X		X	X	X	X	X	X	X
ValueMx	—	Parameter Value Associated with Maximum Flow	X		X	X	X	X	X	X	X
TstOut	—	Tests Frequency 1 Output	X		X	X	X	X	X	X	X
+AltFrq	128	Enables Alternate Frequency and PWM on Frequency 1 Output	X			X	—		X	—	
PlsOM	130	Pulse Output Mode	X			X	—		X	—	
PlsID	131	Pulse Output Item	X			X	—		X	—	
PlsSze	132	Pulse Size	X		X	X	X	X	X	X	X
PlsWth	133	Pulse Width	X			X	—		X	—	
PWMPer	—	Period of Time in ms	X			X	—		X	—	
PWMAIt	—	Percent of PWMPer	X		X	X	X	X	X	X	X

## Main Menu &gt; Set Up &gt; System IO &gt; Com Ports

Parameter	Param. Addr	Description	Password Levels								
			Operator			Technician			Engineer		
			Read	Write		Read	Write		Read	Write	
				Value	Unit / Decimal		Value	Unit / Decimal		Value	Unit / Decimal
ComAdd	1	Communication Address	X			X			X	X	
BaudRate	2	Baud Rate	X		X		X		X	X	
ComPr1	201	Communication Protocol on COM Port 1	X			X			X	X	
HARTAdd	202	Polling Address	X			X			X	X	
ComPr2	260	Communication Protocol on COM Port 2	X			X			X	X	

## Main Menu &gt; Set Up &gt; System IO &gt; Relays

Parameter	Param. Addr	Description	Password Levels								
			Operator			Technician			Engineer		
			Read	Write		Read	Write		Read	Write	
				Value	Unit / Decimal		Value	Unit / Decimal		Value	Unit / Decimal
Relay	241	Relay	X			X			X	X	
InSts	14	In Status	X			X			X		
OutSts	15	Out Status	X			X			X		

## Main Menu &gt; Set Up &gt; System IO &gt; Analog Input

Parameter	Param. Addr	Description	Password Levels								
			Operator			Technician			Engineer		
			Read	Write		Read	Write		Read	Write	
				Value	Unit / Decimal		Value	Unit / Decimal		Value	Unit / Decimal
AnIn1	226	Analog Input 1	X		X	X		X	X	X	
An1Sl	227	Analog Input 1 Slope	X		X	X		X	X	X	
An1Of	228	Analog Input 1 Offset	X		X	X		X	X	X	
AnDmp	246	Analog Input Dampening	X			X	X		X	X	
AnIn2	135	Analog Input 2	X		X	X		X	X		X
An2Sl	232	Analog Input 2 Slope	X		X	X		X	X	X	
An2Of	233	Analog Input 2 Offset	X		X	X		X	X	X	

## Main Menu &gt; Set Up &gt; Menus

Parameter	Param. Addr	Description	Password Levels								
			Operator			Technician			Engineer		
			Read	Write		Read	Write		Read	Write	
				Value	Unit / Decimal		Value	Unit / Decimal		Value	Unit / Decimal
DspTpe	236	Display Type	X			X			X		
MnuBatch	138	Enable/Disable Batch Menu	X			X			X	—	
MnuPID	158	Enable/Disable PID Menu	X			X			X	—	
MnuTot	88	Enable/Disable Totals Menu	X			X			X	—	
MnuAlarm	89	Enable/Disable Alarm Menu	X			X			X	—	
MnuConc	79	Enable/Disable Concentration Menu	X			X			X	—	
MnuApp	37	Enable/Disable Application Menu	X			X	—		X	—	
MnuNet	87	Enable/Disable Net Flow Menu	X			X			X	—	
Scroll	300	Changes Scrolling Direction							X	—	

## Main Menu &gt; Set Up &gt; Program

Parameter	Param. Addr	Description	Password Levels								
			Operator			Technician			Engineer		
			Read	Write		Read	Write		Read	Write	
				Value	Unit / Decimal		Value	Unit / Decimal		Value	Unit / Decimal
BType	99	Batch Type	X			X			X	—	
BMode	94	Batch Mode	X			X			X	—	
BTPrT	95	Batch Timing Pre-trigger	X		X	X		X	X	X	X
BQPrT	96	Batch Quantity Pre-trigger	X		X	X		X	X	X	X
BPrst	97	Batch Preset	X		X	X		X	X	X	X
BSpErr	98	Stops Batch if Error or Alarm Occurs	X			X			X	—	
NFloM	86	Mode of Net Flow Calculation	X			X			X	—	
BxMode	112	Brix Mode	X			X			X	—	
CompAD	110	Density of Component A	X		X	X		X	X	—	X
CompBD	111	Density of Component B	X		X	X		X	X	—	X
A1	113	Brix A1 Coefficient	X		X	X		X	X	X	X
A2	114	Brix A2 Coefficient	X		X	X		X	X	X	X
A3	115	Brix A3 Coefficient	X		X	X		X	X	X	X
B1	116	Brix B1 Coefficient	X		X	X		X	X	X	X
B2	117	Brix B2 Coefficient	X		X	X		X	X	X	X
B3	118	Brix B3 Coefficient	X		X	X		X	X	X	X
C1	181	Brix C1 Coefficient	X		X	X		X	X	X	X
C2	182	Brix C2 Coefficient	X		X	X		X	X	X	X
C3	134	Brix C3 Coefficient	X		X	X		X	X	X	X

## Main Menu &gt; Set Up &gt; Password

Parameter	Param. Addr	Description	Password Levels								
			Operator			Technician			Engineer		
			Read	Write		Read	Write		Read	Write	
				Value	Unit / Decimal		Value	Unit / Decimal		Value	Unit / Decimal
PWSet	142	Sets Password Access Level	X	X		X	X		X	X	
PWLvl	140	Active Password Level	X			X			X		
Pr1	—	Default Password PIN for Operator							X	X	
Pr2	—	Default Password PIN for Technician							X	X	
Pr3	—	Default Password PIN for Engineer							X	X	

## Main Menu &gt; Set Up &gt; Display

Parameter	Param. Addr	Description	Password Levels								
			Operator			Technician			Engineer		
			Read	Write		Read	Write		Read	Write	
				Value	Unit / Decimal		Value	Unit / Decimal		Value	Unit / Decimal
UnitSys	296	Default Engineering Units Setting	X	—		X	—		X	—	
Contrast	9	Contrast Setting	X	X	X	X	X	X	X	X	X
DspTpe	236	Display Type	X			X			X		
TxmType	301	Transmitter Type	X			X			X		
KbLock	303	Keyboard Lock Control	X			X			X	X	
Param1	700	Parameter ID for Home Screen Parameter 1 Slot	X	X		X	X		X	X	
Param2	701	Parameter ID for Home Screen Parameter 2 Slot	X	X		X	X		X	X	
Param3	702	Parameter ID for Home Screen Parameter 3 Slot	X	X		X	X		X	X	
Param4	703	Parameter ID for Home Screen Parameter 4 Slot	X	X		X	X		X	X	
Param5	704	Parameter ID for Home Screen Parameter 5 Slot	X	X		X	X		X	X	
Param6	705	Parameter ID for Home Screen Parameter 6 Slot	X	X		X	X		X	X	
Param7	706	Parameter ID for Home Screen Parameter 7 Slot	X	X		X	X		X	X	
Param8	707	Parameter ID for Home Screen Parameter 8 Slot	X	X		X	X		X	X	

## Main Menu &gt; Batch

(Menu must be enabled.)

Parameter	Param. Addr	Description	Password Levels								
			Operator			Technician			Engineer		
			Read	Write		Read	Write		Read	Write	
				Value	Unit / Decimal		Value	Unit / Decimal		Value	Unit / Decimal
START BATCH	91	Starts a Batch	X	—		X	—		X	—	
STOP BATCH	92	Stops a Batch	X	—		X	—		X	—	
BSpt	93	Batch Setpoint	X	X	X	X	X	X	X	X	X
BTot	90	Batch Total	X		X	X		X	X		X
mTot	80	Mass Total	X		X	X		X	X		X
mFlo	59	Mass Flow Rate	X		X	X		X	X		X
%mFlo	58	Percentage of Mass Flow Rate from Sensor Max	X		X	X		X	X		X
BFloAv	291	Batch Flow Average	X		X	X		X	X		X
Temp1	65	RTD1 Temperature	X		X	X		X	X		X
BP1	195	Batch Preset 1	X		X	X	X	X	X	X	X
BP2	196	Batch Preset 2	X		X	X	X	X	X	X	X
BP3	197	Batch Preset 3	X		X	X	X	X	X	X	X
BP4	198	Batch Preset 4	X		X	X	X	X	X	X	X
BP5	199	Batch Preset 5	X		X	X	X	X	X	X	X
BP6	200	Batch Preset 6	X		X	X	X	X	X	X	X
BEst	288	Batch Estimation	X			X			X		



**Main Menu > PID**

(Menu must be enabled.)

Parameter	Param. Addr	Description	Password Levels								
			Operator			Technician			Engineer		
			Read	Write		Read	Write		Read	Write	
				Value	Unit / Decimal		Value	Unit / Decimal		Value	Unit / Decimal
PSpt	151	PID Setpoint	X	X	X	X	X	X	X	X	X
PID EN	150	PID Enable	X	—		X	—		X	—	
PID ID	159	PID Parameter Identifier	X			X			X	—	
POUT	152	Output Percentage of PID Controller	X		X	X		X	X		X
SamTim	153	PID Sampling Time	X			X			X	—	
PGn	154	PID Gain	X		X	X		X	X	X	X
PDer	155	PID Derivative Factor	X		X	X		X	X	X	X
Plnt	156	PID Integer Factor	X		X	X		X	X	X	X
POfset	157	PID OffSet	X	X	X	X		X	X	X	X
PHold	259	PID Hold	X	—		X	—		X	—	

**Main Menu > Total**

(Menu must be enabled.)

Parameter	Param. Addr	Description	Password Levels								
			Operator			Technician			Engineer		
			Read	Write		Read	Write		Read	Write	
				Value	Unit / Decimal		Value	Unit / Decimal		Value	Unit / Decimal
RESET TOTALS	81	Resets all Resettable Totalizers	X	—		X	—		X	—	
mTot	80	Mass Total	X		X	X		X	X		X
FMTot	239	Forward Mass Total	X		X	X		X	X		X
RMTot	240	Reverse Mass Total	X		X	X		X	X		X
AllTot	82	Non-Resettable Mass Totalizer	X		X	X		X	X		X
mTotWL	83	Mass Totalizer Wrap Limit	X		X	X		X	X	X	X
TotWCnt	31	Totalizer Wrap Count	X	—		X	—		X	—	
vTot	101	Volumetric Total	X		X	X		X	X		X
mFlo	59	Mass Flow Rate	X		X	X		X	X		X
vFlo	100	Volumetric Flow Rate	X		X	X		X	X		X

**Main Menu > Concentration**

(Menu must be enabled.)

Parameter	Param. Addr	Description	Password Levels								
			Operator			Technician			Engineer		
			Read	Write		Read	Write		Read	Write	
				Value	Unit / Decimal		Value	Unit / Decimal		Value	Unit / Decimal
mFloA	104	Mass Flow Rate of Component A	X		X	X		X	X		X
mFloB	105	Mass Flow Rate of Component B	X		X	X		X	X		X
mFlo	59	Mass Flow Rate	X		X	X		X	X		X
mTotA	106	Mass Total of Component A	X		X	X		X	X		X
mTotB	107	Mass Total of Component B	X		X	X		X	X		X
m%A	108	Mass Flow of Component A as a Percentage	X		X	X		X	X	X	X
m%B	109	Mass Flow of Component B as a Percentage	X		X	X		X	X	X	X
Temp1	65	RTD1 Temp.	X		X	X		X	X		X
Dens	70	Density	X		X	X		X	X		X

## Main Menu &gt; Application

Parameter	Param. Addr	Description	Password Levels								
			Operator			Technician			Engineer		
			Read	Write		Read	Write		Read	Write	
				Value	Unit / Decimal		Value	Unit / Decimal		Value	Unit / Decimal
WI1	175	Work Item 1	X	X	X	X	X	X	X	X	X
WI2	172	Work Item 2	X	X	X	X	X	X	X	X	X
WI3	242	Work Item 3	X	X	X	X	X	X	X	X	X
WI4	243	Work Item 4	X	X	X	X	X	X	X	X	X
StdVol	244	Work Item 5	X	X	X	X	X	X	X	X	X
StdVflo	245	Work Item 6	X	X	X	X	X	X	X	X	X
WI7	248	Work Item 7	X	X	X	X	X	X	X	X	X
WI8	249	Work Item 8	X	X	X	X	X	X	X	X	X
WI9	250	Work Item 9	X	X	X	X	X	X	X	X	X
WBit	174	Work Bit	X	X		X	X		X	X	
API	176	API Gravity	X	X		X	X		X	X	
Baume	177	Degrees Baume	X	X		X	X		X	X	
mFlo	59	Mass Flow Rate	X	X	X	X	X	X	X	X	X
Temp1	65	RTD1 Temp.	X		X	X		X	X		X
Dens	70	Density	X		X	X		X	X		X

## Main Menu &gt; Net Flow

Parameter	Param. Addr	Description	Password Levels								
			Operator			Technician			Engineer		
			Read	Write		Read	Write		Read	Write	
				Value	Unit / Decimal		Value	Unit / Decimal		Value	Unit / Decimal
RemFlo	55	Remote Mass Flow Rate	X		X	X		X	X		X
mFlo	59	Mass Flow Rate	X		X	X		X	X		X
NetFlo	56	Net Flow Rate	X		X	X		X	X		X
NetVflo	57	Net Volumetric Flow	X		X	X		X	X		X
RemTot	84	Remote Mass Total	X		X	X		X	X		X
NetmTot	85	Net Mass Total	X		X	X		X	X		X
mTot	80	Mass Total	X		X	X		X	X		X
NetVTot	103	Net Volumetric Total	X		X	X		X	X		X
RemVTot	102	Remote Volumetric Total	X		X	X		X	X		X

## Main Menu &gt; Alarms &gt; Alarm-A

Parameter	Param. Addr	Description	Password Levels								
			Operator			Technician			Engineer		
			Read	Write		Read	Write		Read	Write	
				Value	Unit / Decimal		Value	Unit / Decimal		Value	Unit / Decimal
ID A	—	Parameter ID of Alarm A	X			X	—		X	—	
EN A	—	Enable Alarm A	X			X	—		X	—	
ALo	—	Alarm A Low Limit	X		X	X	X	X	X	X	X
AHi	—	Alarm A High Limit	X		X	X	X	X	X	X	X

## Main Menu &gt; Alarms &gt; Alarm-B

Parameter	Param. Addr	Description	Password Levels								
			Operator			Technician			Engineer		
			Read	Write		Read	Write		Read	Write	
				Value	Unit / Decimal		Value	Unit / Decimal		Value	Unit / Decimal
ID B	173	Parameter ID of Alarm B	X			X	—		X	—	
EN B	—	Enable Alarm B	X			X	—		X	—	
BLo	—	Alarm B Low Limit	X		X	X	X	X	X	X	X
BHi	—	Alarm B High Limit	X		X	X	X	X	X	X	X

## Main Menu &gt; Alarms &gt; Alarm-C

Parameter	Param. Addr	Description	Password Levels								
			Operator			Technician			Engineer		
			Read	Write		Read	Write		Read	Write	
				Value	Unit / Decimal		Value	Unit / Decimal		Value	Unit / Decimal
ID C	—	Parameter ID of Alarm C	X			X	—		X	—	
EN C	—	Enable Alarm C	X			X	—		X	—	
CLo	—	Alarm C Low Limit	X		X	X	X	X	X	X	X
CHi	—	Alarm C High Limit	X		X	X	X	X	X	X	X

## Main Menu &gt; Alarms &gt; Alarm-D

Parameter	Param. Addr	Description	Password Levels								
			Operator			Technician			Engineer		
			Read	Write		Read	Write		Read	Write	
				Value	Unit / Decimal		Value	Unit / Decimal		Value	Unit / Decimal
ID D	—	Parameter ID of Alarm D	X			X	—		X	—	
EN D	—	Enable Alarm D	X			X	—		X	—	
DLo	—	Alarm D Low Limit	X		X	X	X	X	X	X	X
DHi	—	Alarm D High Limit	X		X	X	X	X	X	X	X

## Main Menu &gt; Alarms &gt; Alarm-E

Parameter	Param. Addr	Description	Password Levels								
			Operator			Technician			Engineer		
			Read	Write		Read	Write		Read	Write	
				Value	Unit / Decimal		Value	Unit / Decimal		Value	Unit / Decimal
ID E	—	Parameter ID of Alarm E	X			X	—		X	—	
EN E	—	Enable Alarm E	X			X	—		X	—	
ELo	—	Alarm E Low Limit	X		X	X	X	X	X	X	X
EHi	—	Alarm E High Limit	X		X	X	X	X	X	X	X

## Main Menu &gt; Alarms &gt; Alarm-F

Parameter	Param. Addr	Description	Password Levels								
			Operator			Technician			Engineer		
			Read	Write		Read	Write		Read	Write	
				Value	Unit / Decimal		Value	Unit / Decimal		Value	Unit / Decimal
ID F	—	Parameter ID of Alarm F	X			X	—		X	—	
EN F	—	Enable Alarm F	X			X	—		X	—	
FLo	—	Alarm F Low Limit	X		X	X	X	X	X	X	X
FHi	—	Alarm F High Limit	X		X	X	X	X	X	X	X

## Main Menu &gt; Alarms &gt; EAlmOut

Parameter	Param. Addr	Description	Password Levels								
			Operator			Technician			Engineer		
			Read	Write		Read	Write		Read	Write	
				Value	Unit / Decimal		Value	Unit / Decimal		Value	Unit / Decimal
EAlmOut	290	Enables or Disables Alarm Signal on OPTO#4 Output	X			X			X	—	

## RCT CONSOLE BASICS

RCT Console is a software program for monitoring, diagnostics and configuration for Badger Meter Coriolis transmitters. The following procedure is for setup of the program only. For assistance with configuration, features and functions, refer to the software help file.

### Minimum System Requirements

#### Operating System

Target systems must meet the following minimum operating system requirement:

- Windows XP
- Windows Server 2003
- Windows Vista
- Windows Server 2008
- Windows 7
- Windows Server 2008 R2
- Windows 8
- Windows 10

**NOTE:** Microsoft .NET Framework version 3.5 with Service Pack 2 or later must be installed.

#### Hardware

PC to software communication can be done via EIA-485 or through a Mini-B USB cable. USB to serial port, Bluetooth serial port or any combination of RS232, USB and Bluetooth communication port is allowed.

#### Setup

1. Install the RCT Console software on the Host PC.

The software program should be up to date. On Startup, the program will check to see if there is a new version available. If a new version is available, follow the prompts to update the program before proceeding to the next step.

**NOTE:** To change the language, see *"Changing the Language on the RCT Console"* on page 106.

2. Connect the RCT1000 Transmitter to the host PC.
3. On the *Transmitter Explorer* tab, click the **Add Device** icon, then click on **Transmitter Manager**.

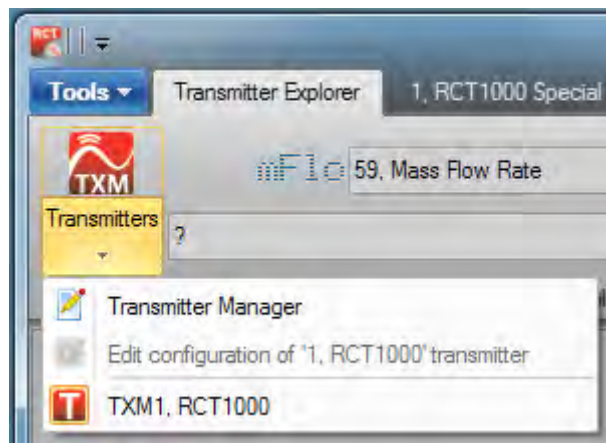

Figure 69: Transmitter explorer

4. Click the **Add New Transmitter** icon.

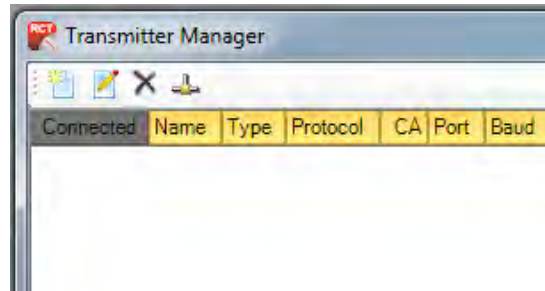

Figure 70: Add new transmitters

The *Edit Transmitter* window displays:

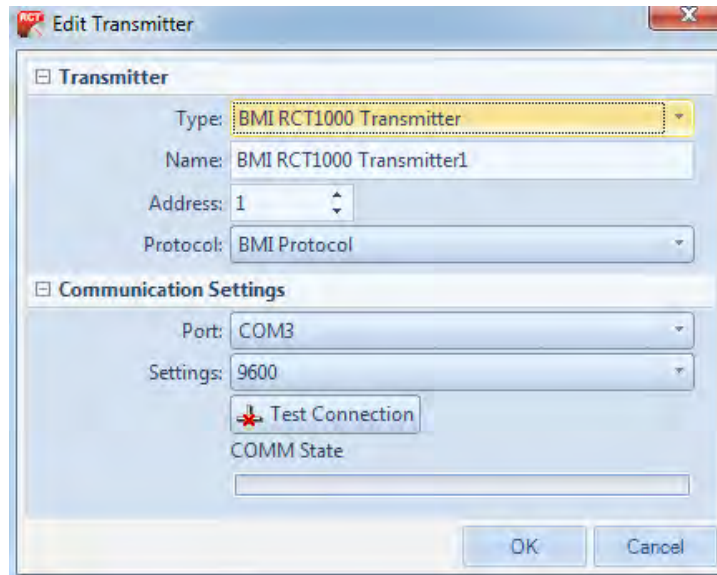

Figure 71: Edit transmitter

5. Under *Type*, make sure the *BMI RCT1000 Transmitter* is selected.
6. Under *Name*, give this configuration a name that applies to the location of the transmitter. This helps when there could possibly be multiple meters in one location. RCT Console will save the configuration for each Transmitter.
7. Under *Address*, select the address that is indicated in the transmitter. To find the address, go to *Main Menu > SETUP > SYSTEM IO > COM PORTS > ComAdd*. The value located on the right of this parameter is the address to be entered into the software.
8. Under *Protocol*, select **BMI Protocol**.
9. Click **Test Connection** to check all available COM Ports at all Baud Rates to find the transmitter. A prompt will appear indicating that the transmitter was found. Click **OK** and exit the Transmitter Manager.

The program should now be communicating with the connected transmitter.

## Changing the Language on the RCT Console

1. On the *Tools* tab, select **Options**.

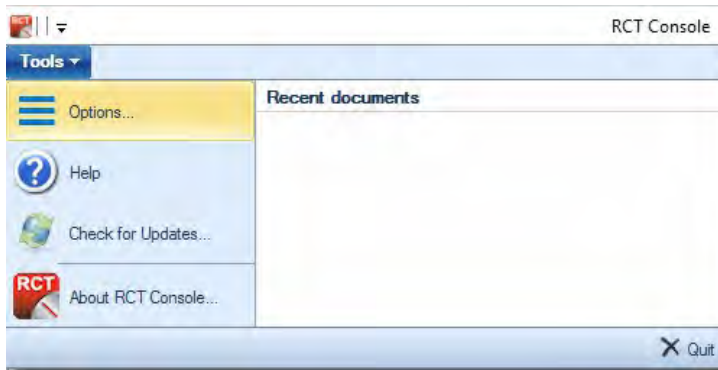

Figure 72: Select tools > options

2. Select the drop-down menu from the *Appearance > Language* dropbox.

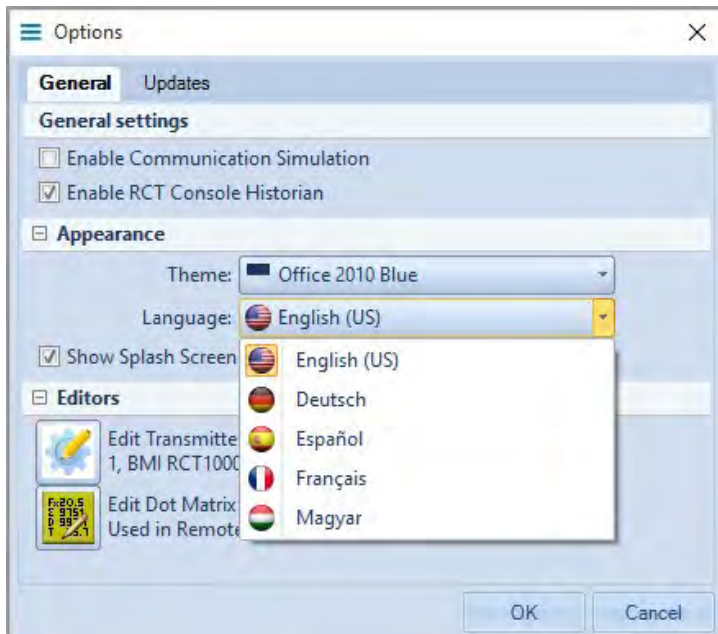

Figure 73: Select a language

3. After selecting the language, the text will change. Click **OK** to accept the new language.



Figure 74: Accept the new language

## GLOSSARY

**Batching:** A manufacturing process where exact amounts of product are dosed into a vessel based on a recipe ingredient list.

**Brix:** A unit representation of the sugar content of an aqueous solution.

**Baume:** A unit representation of the sugar concentration in juice or wine

**Cavitation:** A sudden appearance of gaseous phase in a liquid due to a pressure drop below its vapor pressure, which can occur as fluids exit an orifice plate, control valve or on suction of a pump.

**Class 1 Div 1:** An area classification that indicates the area is in the presence of flammable gases or vapors in the air and is normally explosive or hazardous.

**Class 1 Div 2:** An area classification that indicates the area is in the presence of flammable gases or vapors in the air and is not normally present in an explosive concentration, but may accidentally exist.

**Condensate:** Formed by the condensation reaction making a liquid.

**Density:** Density is a physical property, constant at a given temperature. Density can help to identify a substance.

**Feedback:** Feedback control of a system is done by comparing the output with a reference and generating a correcting signal.

**Frequency Response:** The amount the oscillating frequency of the Coriolis sensor tubes changes due to a change in Density of the fluid being measured.

**HART:** A communication protocol that has been used in industrial applications for the configuration and reading of legacy like devices.

**Homogenous Liquid:** A liquid that is composed of parts or elements that are all of the same kind, or single phase.

**Integral:** A term used within the flow meter industry that means the electronics used to read and display flow meter output is directly mounted to the flow meter housing.

**Intrinsically Safe (I.S.):** A protection technique for the safe operation of electronic equipment in explosive or hazardous areas.

**Laminar Flow:** Reynolds number below 2000. Fluid molecules do not mix with each other and flow in straight lines within the pipe. This causes variations in velocity due to pipe wall friction as compared to the center of the pipe where no friction takes place.

**Mass:** A measure of the amount of material in an object, being directly related to the number and type of atoms present in the object. An objects Mass does not change with a body's position, movement or alteration of its shape, unless material is added or removed.

**Modbus:** A communication protocol used for the communication and configuration of devices connected to different types of buses or networks.

**NEMA 4:** A standard from the National Electrical Manufacturers Association which defines enclosure ratings. Type 4 is constructed and rated for either indoor or outdoor use and provides a degree of protection against access to hazardous parts, ingress of solid foreign objects, ingress of water and remain undamaged by the external formation of ice.

**NEMA 4X:** A standard from the National Electrical Manufacturers Association which defines enclosure ratings. Type 4X is constructed and rated to be the same as type 4, but with the addition of a level of protection against corrosion.

**Percent Solids:** The measurement of a solid material that has virtually no density change relative to temperature suspended in a liquid carrier. Titanium dioxide and calcium carbonate are examples of slurry applications.

**Percent Soluble:** The measurement of two liquids in a flow stream. Coriolis meters can determine percent concentration of each component in a two component stream by its density value.

**Phase Shift:** The difference between two sinusoidal wave signals, at which point they cross a zero reference point from positive to negative values.

**PID:** Proportional, Integral and Derivative; terms in the algorithm for automated process control loops or PID loops.

**Pressure Drop:** The process line pressure loss across a barrier in the flow stream as a fluid passes through it.

**Ratio Control:** Is a control scheme that sets the flow rate in one flow loop to a certain value, based upon an input signal from a second flow loop and a ratio multiplier. This can be a liquid : liquid or a liquid : solid ratio system.

**Repeatability:** Similar to uncertainty, this is a percentage within a specification that indicates at any point within the flow range of a meter, the actual output will be the same if that point is selected again at a different time.

**Resonance Error:** Indicates the Coriolis meters resonant frequency is not vibrating within a predetermined range.



**Reynolds Number:** A unit-less number that represents the flow regime within a pipe denoting laminar or turbulent flow conditions.

**Sensor Warning:** An alarm message displayed when the feedback coils of a Coriolis meter are not maintaining the desired set point level. Typically caused by imbalance within the meter due to gas bubbles in a liquid application or settling solids of a slurry application.

**Slug Flow:** A process condition where sections of the pipeline will have large amount of gas bubbles accumulated and travel with the liquid during flow conditions

**Slurry:** A semi-liquid mixture.

**Specific Gravity:** SG of a liquid is a dimensionless unit defined as the ratio of density of the liquid to the density of water at a specified temperature. It is common to use the density of water at 39° F (4° C) as reference. At this point the density of water is at the highest (1000 kg/m<sup>3</sup> or 62.4 lb/ft<sup>3</sup>).

**Temperature Compensation:** To adjust a measurement for thermal changes in a process. Typically used for expansion or spring constant characteristics of a metal component.

**Thixotropic:** The property of certain fluids whereby they become less viscous when agitated and return to being high viscosity when allowed to stand. Ketchup is a good example of this as its property in a normal state is thick and when pressure is applied to it its molecules “sheer” against each other causing it to flow easily.

**Transition Flow:** Reynolds Number between 2000...4000 where both laminar and turbulent conditions can occur within the pipe.

**Turbulent Flow:** Reynolds Number above 4000. Fluid molecules do interact in random motion throughout the pipe and causes virtually the same velocity from the wall to the center of the pipe.

**Uncertainty:** A percentage based number within a specification that is an indication of a meter’s flow output is within a certain percentage. This can also be defined as the accuracy of the measurement from the reading, of full scale or of actual flow rate.

**Viscosity:** A measure of a fluids ability to resist external influences attempting to change its form. High viscosity fluids are thick and resist movement when a pressure is applied to them where as low viscosity fluids tend to more quite easily with little pressure applied to them.

**Weight:** The gravitational force acting on the mass of a body.

**Wetted Material:** Parts within a measuring system that come in contact with the fluid being metered/measured.

**Zero Stability:** Refers to the stability of the phase shift measurement in the Coriolis meter with no flow conditions. Directly related to the balance of the sensing tubes.

**INTENTIONAL BLANK PAGE**

**INTENTIONAL BLANK PAGE**

## Control. Manage. Optimize.

Trademarks appearing in this document are the property of their respective entities. Due to continuous research, product improvements and enhancements, Badger Meter reserves the right to change product or system specifications without notice, except to the extent an outstanding contractual obligation exists. © 2017 Badger Meter, Inc. All rights reserved.

**[www.badgermeter.com](http://www.badgermeter.com)**

---

**The Americas | Badger Meter** | 4545 West Brown Deer Rd | PO Box 245036 | Milwaukee, WI 53224-9536 | 800-876-3837 | 414-355-0400  
**México | Badger Meter de las Americas, S.A. de C.V.** | Pedro Luis Ogazón N°32 | Esq. Angelina N°24 | Colonia Guadalupe Inn | CP 01050 | México, DF | México | +52-55-5662-0882  
**Europe, Middle East and Africa | Badger Meter Europa GmbH** | Nurtinger Str 76 | 72639 Neuffen | Germany | +49-7025-9208-0  
**Europe, Middle East Branch Office | Badger Meter Europe** | PO Box 341442 | Dubai Silicon Oasis, Head Quarter Building, Wing C, Office #C209 | Dubai / UAE | +971-4-371 2503  
**Czech Republic | Badger Meter Czech Republic s.r.o.** | Mařikova 2082/26 | 621 00 Brno, Czech Republic | +420-5-41420411  
**Slovakia | Badger Meter Slovakia s.r.o.** | Racianska 109/B | 831 02 Bratislava, Slovakia | +421-2-44 63 83 01  
**Asia Pacific | Badger Meter** | 80 Marine Parade Rd | 21-06 Parkway Parade | Singapore 449269 | +65-63464836  
**China | Badger Meter** | 7-1202 | 99 Hangzhong Road | Minhang District | Shanghai | China 201101 | +86-21-5763 5412  
**Switzerland | Badger Meter Swiss AG** | Mittelholzerstrasse 8 | 3006 Bern | Switzerland | +41-31-932 01 11