



TWO-WIRE TRANSMITTERS FOR pH, ORP, CONDUCTIVITY, OXYGEN, OZONE, AND CHLORINE

Model Xmt™¹ Family of Two-wire Transmitters

- CHOICE OF COMMUNICATION PROTOCOLS: **HART**  or **FOUNDATION**  Fieldbus
- CLEAR, EASY-TO-READ two-line display shows commissioning menus and process measurement displays in English
- SIMPLE TO USE MENU STRUCTURE
- CHOICE OF PANEL OR PIPE/SURFACE MOUNTING
- NON-VOLATILE MEMORY retains program settings and calibration data during power failures
- SIX LOCAL LANGUAGES — English, French, German, Italian, Spanish and Portuguese



FEATURES AND APPLICATIONS

The Solu Comp®⁴ Model Xmt™ family of transmitters can be used to measure pH, ORP, conductivity (using either contacting or toroidal sensors), resistivity, oxygen (ppm and ppb level), free chlorine, total chlorine, monochloramine and ozone in a variety of process liquids. The Xmt is compatible with most Rosemount Analytical sensors. See the Specification sections for details.

The transmitter has a rugged, weatherproof, corrosion-resistant enclosure (NEMA 4X and IP65). The panel mount version fits standard ½ DIN panel cutouts, and its shallow depth is ideally suited for easy mounting in cabinet-type enclosures. A panel mount gasket is included to maintain the weather rating of the panel. Surface/pipe mount enclosure includes self-tapping screws for surface mounting. A pipe mounting accessory kit is available for mounting to a 2-inch pipe.

The transmitter has a two-line 16-character display. Menu screens for calibrating and registering choices are simple and intuitive. Plain language prompts guide

the user through the procedures. There are no service codes to enter before gaining access to menus.

Two digital communication protocols are available: HART® (model option -HT) and FOUNDATION® fieldbus (model option -FF or FI). Digital communications allow access to AMS (Asset Management Solutions). Use AMS to set up and configure the transmitter, read process variables, and troubleshoot problems from a personal computer or host anywhere in the plant.

The seven-button membrane-type keypad allows local programming and calibrating of the transmitter. The HART® and FOUNDATION® fieldbus Model 375 communicator can also be used for programming and calibrating transmitters.

¹ Xmt is a trademark of Rosemount Analytical.

² HART is a registered trademark of the HART Communication Foundation.

³ FOUNDATION is a registered trademark of Fieldbus Foundation.

⁴ Solu Comp is a registered trademark of Rosemount Analytical.

Model Xmt-P pH/ORP Transmitter

- CHANGING FROM pH TO ORP operation takes only seconds.
- AUTOMATIC TWO-POINT BUFFER CALIBRATION reduces errors.
- SOLUTION TEMPERATURE COMPENSATION converts measured pH to the pH at 25°C.
- CONTINUOUS DIAGNOSTICS monitor sensor performance and warn the user of failure (FAULT) or approaching failure (WARNING).

Model Xmt-C Contacting Conductivity Transmitter

- MEASURES CONDUCTIVITY, RESISTIVITY, TOTAL DISSOLVED SOLIDS, OR CUSTOM CURVE VARIABLE.
- AUTOMATIC TEMPERATURE SENSOR RECOGNITION simplifies start up.
- AUTOMATIC COMPENSATION FOR SENSOR CABLE RESISTANCE improves accuracy of high conductivity/ low resistivity measurements.*
- TEMPERATURE COMPENSATION ALGORITHMS include percent slope, ultra-pure water, cation conductivity, and no compensation.

Model Xmt-T Toroidal Conductivity Transmitter

- MEASURES CONDUCTIVITY, PERCENT CONCENTRATION, TOTAL DISSOLVED SOLIDS, OR CUSTOM CURVE VARIABLE.
- AUTOMATIC TEMPERATURE SENSOR RECOGNITION simplifies start up.
- AUTOMATIC/MANUAL TEMPERATURE COMPENSATION ensures accurate monitoring and control.
- BUILT-IN CONCENTRATION CURVES FOR 0-12% NaOH, 0-15% HCl, 0-20% NaCl, and 0-25% H₂SO₄, and 96.0-99.7% H₂SO₄.
- PROGRAMMABLE REFERENCE TEMPERATURE enables temperature compensation to temperatures other than 25 degrees Celsius.
- AUTOMATIC COMPENSATION FOR SENSOR CABLE RESISTANCE improves accuracy of high conductivity measurements.*

Model Xmt-A Amperometric Transmitter

- MEASURES dissolved oxygen (ppm and ppb level), free chlorine, total chlorine, monochloramine, and ozone.
- SECOND INPUT FOR A pH SENSOR ALLOWS AUTOMATIC pH CORRECTION for free chlorine measurement. No expensive, messy reagents needed.
- AUTOMATIC BUFFER RECOGNITION FOR pH CALIBRATION.

**Patent pending*

SPECIFICATIONS - GENERAL

Case: Polycarbonate (panel and surface/pipe mount).
NEMA 4X/CSA 4 (IP65)

Dimensions

Panel (code -10): 6.10 x 6.10 x 3.72 in.
(155 x 155 x 94.5 mm)

Surface/Pipe (code -11): 6.23 x 6.23 x 3.23 in.
(158 x 158 x 82 mm); see page 15 for dimensions of pipe mounting bracket.

Conduit openings: Accepts PG13.5 or 1/2 in. conduit fittings

Ambient Temperature: 32 to 122°F (0 to 50°C).
Some degradation of display above 50°C.

Storage Temperature: -4 to 158°F (-20 to 70°C)

Relative Humidity: 10 to 90% (non-condensing)

Weight/Shipping Weight: 2 lb/3 lb (1 kg/1.5 kg)

Display: Two line, 16-character display. Character height: 4.8 mm; first line shows process variable (pH, ORP, conductivity, % concentration, oxygen, ozone, chlorine, or monochloramine), second line shows process temperature and output current. For pH/chlorine combination, pH may also be displayed. Fault and warning messages, when triggered, alternate with temperature and output readings.

During calibration and programming, messages, prompts, and editable values appear on the two-line display.

Temperature resolution: 0.1°C ($\leq 99.9^\circ\text{C}$);
1°C ($\geq 100^\circ\text{C}$)

Hazardous Location Approval: For details, see specifications for the measurement of interest.

RFI/EMI: EN-61326 

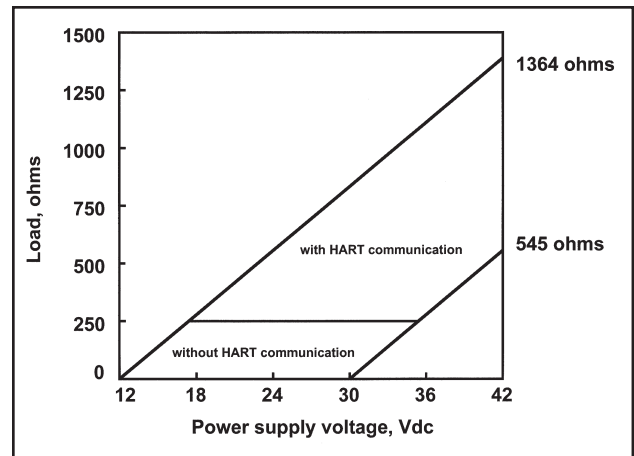

DIGITAL COMMUNICATIONS:

HART —

Power & Load Requirements: Supply voltage at the transmitter terminals should be at least 12 Vdc. Power supply voltage should cover the voltage drop on the cable plus the external load resistor required for HART communications (250 Ω minimum). Minimum power supply voltage is 12 Vdc. Maximum power supply voltage is 42.4 Vdc. The graph shows the supply voltage required to maintain 12 Vdc (upper line) and 30 Vdc (lower line) at the transmitter terminals when the current is 22 mA.

Analog Output: Two-wire, 4-20 mA output with superimposed HART^{®3} digital signal. Fully scalable over the operating range of the sensor.

Output accuracy: ± 0.05 mA

FOUNDATION FIELDBUS —

Power & Load Requirements: A power supply voltage of 9-32 Vdc at 13 mA is required.

Fieldbus Intrinsically Safe **CO**ncept/FISCO-compliant versions of Model Xmt Foundation Fieldbus transmitters are available.

MODEL Xmt-A AMPEROMETRIC TRANSMITTER

FEATURES

The Model Xmt-A Transmitter with the appropriate sensor measures dissolved oxygen (ppm and ppb level), free chlorine, total chlorine, monochloramine, and ozone in water and aqueous solutions. The transmitter is compatible with Rosemount Analytical 499A amperometric sensors for oxygen, chlorine, monochloramine, and ozone; and with Hx438, Bx438, and Gx448 steam-sterilizable oxygen sensors.

For free chlorine measurements, both automatic and manual pH correction are available. pH correction is necessary because amperometric free chlorine sensors respond only to hypochlorous acid, not free chlorine, which is the sum of hypochlorous acid and hypochlorite ion. To measure free chlorine, most competing instruments require an acidified sample. Acid lowers the pH and converts hypochlorite ion to hypochlorous acid. The Model Xmt-A eliminates the need for messy and expensive sample conditioning by

measuring the sample pH and using it to correct the chlorine sensor signal. If the pH is relatively constant, a fixed pH correction can be used, and the pH measurement is not necessary. If the pH is greater than 7.0 and fluctuates more than about 0.2 units, continuous measurement of pH and automatic pH correction is necessary. See Specifications section for recommended pH sensors. Corrections are valid to pH 9.5.

The transmitter fully compensates oxygen, ozone, free chlorine, total chlorine, and monochloramine readings for changes in membrane permeability caused by temperature changes.

For pH measurements — pH is available with free chlorine only — the Xmt-A features automatic buffer recognition and stabilization check. Buffer pH and temperature data for commonly used buffers are stored in the transmitter. Glass impedance diagnostics warn the user of an aging or failed pH sensor.

GENERAL SPECIFICATIONS FOR Xmt-A

Input ranges: 0-330 nA, 0.3-4µA, 3.7-30 µA, 27-100 µA

Repeatability (input): ±0.1% of range

Linearity (input): ±0.3% of range

Temperature range: -10 to 100°C (-10 to 150°C for steam sterilizable sensors)

Temperature accuracy using RTD: ±0.5°C between 0 and 50°C, ±1°C above 50°C

Temperature accuracy using 22k NTC: ±0.5°C between 0 and 50°C, ±2°C above 50°C

Digital Communications:

HART: PV, SV, TV, and 4V assignable to measurement (oxygen, ozone, chlorine, or monochloramine), temperature, pH, and sensor current.

Fieldbus: Four (4) AI blocks assignable to measurement (oxygen, ozone, or chlorine), temperature, pH, and sensor current; execution time 75 msec. One PID block; execution time 150 msec. Device type: 4086. Device revision: 1. Certified to ITK 4.6.

HAZARDOUS LOCATION APPROVALS

Intrinsic Safety (with appropriate safety barrier):



Class I, II, III, Div. 1
Groups A-G
T4 Tamb = 50°C



Class I, II, III, Div. 1
Groups A-G
T4 Tamb = 50°C

ATEX



CE 1180 II 1 G
Baseefa04ATEX0213X
EEx ia IIC T4
Tamb = 0°C to 50°C

Non-Incendive:



Class I, Div. 2, Groups A-D
Dust Ignition Proof
Class II & III, Div. 1, Groups E-G
NEMA 4/4X Enclosure



Class I, Div. 2, Groups A-D
Dust Ignition Proof
Class II & III, Div. 1, Groups E-G
NEMA 4/4X Enclosure
T4 Tamb = 50°C

MODEL Xmt-A AMPEROMETRIC TRANSMITTER

SPECIFICATIONS — OXYGEN

Measurement Range: 0-20 ppm (mg/L),
or equivalent partial pressure or % saturation
(limited by sensor)

Units: ppm, ppb, % saturation, partial pressure
(mmHg, inHg, atm, mbar, bar, kPa)

Resolution: 4 digits. Position of decimal point
depends on units selected

for partial pressure (x.xxx to xxxx)

for % saturation (fixed at xxx.x%)

for ppm (fixed at xx.xx ppm) =,

for ppb (fixed at xxx.x ppb, changes to 1.00 ppm
when ppb reading exceeds 999.9 ppb) =,xxxxppm

Temperature correction for membrane permeability:
automatic between 0 and 50°C (can be disabled)

Calibration: air calibration (user must enter baromet-
ric pressure) or calibration against a standard
instrument

SENSORS — OXYGEN:

Model 499A DO-54, 499A DO-54-VP for ppm level

Model 499A TrDO-54, 499A TrDO-54-VP for ppb level

Hx438, Bx438, and Gx448 steam-sterilizable oxygen
sensors

SPECIFICATIONS — FREE CHLORINE

Measurement Range: 0-20 ppm (mg/L) as Cl₂
(limited by sensor)

Resolution: 0.001 ppm (Autoranges at 0.999 to 1.00
and 9.99 to 10.0)

Temperature correction for membrane permeability:
automatic between 0 and 50°C (can be disabled)

pH Correction: Automatic between pH 6.0 and 9.5.
Manual pH correction is also available.

Calibration: against grab sample analyzed using
portable test kit.

SENSORS — FREE CHLORINE:

Model 499A CL-01-54, 499A CL-01-54-VP

SPECIFICATIONS — TOTAL CHLORINE

Measurement Range: 0-20 ppm (mg/L) as Cl₂
(limited by sensor)

Resolution: 0.001 ppm (Autoranges at 0.999 to 1.00
and 9.99 to 10.0)

Temperature correction for membrane permeability:
automatic between 5 and 35°C (can be disabled)

Calibration: against grab sample analyzed using
portable test kit.

SENSOR — TOTAL CHLORINE:

Model 499A CL-02-54 (must be used with SCS 921A)

SPECIFICATIONS — pH

Application: pH measurement available with free
chlorine only

Measurement Range: 0-14 pH

Resolution: 0.01 pH

Sensor Diagnostics: Glass impedance (for broken
or aging electrode) and reference offset.

Reference impedance (for fouled reference junc-
tion) is not available.

Repeatability: ±0.01 pH at 25°C

SENSORS — pH:

Use Model 399-09-62, 399-14, or 399VP-09.

SPECIFICATIONS — MONOCHLORAMINE

Measurement Range: 0-20 ppm (mg/L) as Cl₂
(limited by sensor)

Resolution: 0.001 ppm (Autoranges at 0.999 to 1.00
and 9.99 to 10.0)

Temperature correction for membrane permeability:
automatic between 5 and 35°C (can be disabled)

Calibration: against grab sample analyzed using
portable test kit.

SENSORS — MONOCHLORAMINE:

Model 499A CL-03-54, 499A CL-03-54-VP

SPECIFICATIONS — OZONE

Measurement Range: 0-10 ppm (mg/L) (limited by
sensor)

Units: ppm and ppb

Resolution:

for ppm: x.xxx to xxxx

for ppb: xxx.x to xxxx

Temperature correction for membrane permeability:
automatic between 5 and 35°C (can be disabled)

Calibration: against grab sample analyzed using
portable test kit.

SENSORS — OZONE:

Model 499A OZ-54, 499A OZ-54-VP

MODEL Xmt-P pH/ORP TRANSMITTER

FEATURES

The Model Xmt-P Transmitter with the appropriate sensor can be configured for either pH or ORP (oxidation reduction potential) measurement of aqueous solutions. Housed in a NEMA 4X case, the Model Xmt can be located close to the sensor even in the harshest environments, including process, water or wastewater monitoring. Advanced features include automatic 2-point buffer calibration routine, automatic recognition of Pt 100 or Pt 1000 RTD, and menu-selected internal preamplifier. Predictive sensor diagnostic capability is possible through the impedance measurement of the pH glass membrane and reference electrode, fully supported by AMS. Solution temperature calibration allows the instrument to calculate and display the pH at 25°C when the temperature coefficient of the measured liquid is provided.

FUNCTIONAL SPECIFICATIONS

pH Range: 0 to 14

ORP Range: -1400 to +1400mV

Calibrations/standardization: The automatic buffer recognition uses stored buffer values and their temperature curves for the most common buffer standards available worldwide. The transmitter also performs a stabilization check on the sensor in each buffer.

A manual two-point calibration is made by immersing the sensor in two different buffer solutions and entering the pH values. The microprocessor automatically calculates the slope which is used for self-diagnostics. An error message will be displayed if the pH sensor is faulty. This slope can be read on the display and/or manually adjusted if desired.

An on-line one-point process standardization is accomplished by entering the pH or ORP value of a grab sample.

Preamplifier Location: A preamplifier must be used to convert the high impedance pH electrode signal to a low impedance signal for transmitter use. The integral preamplifier of the Model Xmt-P may be used when the sensor to transmitter distance is less than 15 ft (4.5 m). Locate the preamplifier in the sensor or junction box for longer distances.

Automatic Temperature Compensation: External 3-wire Pt100 RTD or Pt1000 RTD located in the sensor, compensates the pH reading for temperature fluctuations. Compensation covers the range -15 to 130°C (5 to 270°F). Manual temperature compensation is also selectable.

Accuracy: ±1 mV @ 25°C ±0.01 pH

Repeatability: ±1 mV @ 25°C ±0.01 pH

Diagnostics: The internal diagnostics can detect:

Calibration Error	Sensor Failure
High Temperature Warning	CPU Failure
Low Temperature Warning	Input Warning
ROM Failure	Glass Warning
Glass Failure	Reference Warning
Reference Failure	

Once one of the above is diagnosed, the display will show a message describing the problem.

DIGITAL COMMUNICATIONS:

HART (pH): PV assigned to pH. SV, TV, and 4V assignable to pH, temperature, mV, glass impedance, reference impedance, or RTD resistance.

HART (ORP): PV assigned to ORP. SV, TV, and 4V assignable to ORP, temperature, reference impedance, or RTD resistance.

Fieldbus (pH): Four AI blocks assigned to pH, temperature, reference impedance, and glass impedance.

Fieldbus (ORP): Three AI blocks assigned to ORP, temperature, and reference impedance.

Fieldbus (pH and ORP): Execution time 75 msec. One PID block; execution time 150 msec. Device type 4088. Device revision 1. Certified to ITK 4.6.

HAZARDOUS LOCATION APPROVALS

Intrinsic Safety (with appropriate safety barrier):



Class I, II, III, Div. 1
Groups A-G
T4 Tamb = 50°C



Class I, II, III, Div. 1
Groups A-G
T4 Tamb = 50°C

ATEX



CE 1180 II 1 G
Baseefa04ATEX0213X
EEx ia IIC T4
Tamb = 0°C to 50°C

Non-Incendive:



Class I, Div. 2, Groups A-D
Dust Ignition Proof
Class II & III, Div. 1, Groups E-G
NEMA 4/4X Enclosure



Class I, Div. 2, Groups A-D
Dust Ignition Proof
Class II & III, Div. 1, Groups E-G
NEMA 4/4X Enclosure
T4 Tamb = 50°C

MODEL Xmt-P pH/ORP TRANSMITTER

SENSOR COMPATIBILITY CHART	
pH/ORP SENSOR	DIAGNOSTIC CAPABILITY
320HP-58	Glass only
328A	Glass only
370	Glass only
371	Glass only
372	Glass only
381 pHE-31-41-52	Glass only
381+	Glass and Reference
385+	Glass and Reference
389-02-54 / 389VP-54	Glass only
396-54-62 / 396VP	Glass only
396P-55 / 396PVP-55	Glass and Reference
396R / 396RVP-54	Glass and Reference
397-54-62	Glass only
398-54-62 / 398VP-54	Glass only
398R-54-62 / 398RVP-54	Glass only
399-09-62 / 399VP-09 / 399-14	Glass only
Hx338	Glass only
Hx348	Glass only
TF396	none

MODEL Xmt-C CONTACTING CONDUCTIVITY TRANSMITTER

FEATURES

The Model Xmt-C measures conductivity, resistivity, total dissolved solids, or % concentration. It can also be configured, using the "Custom Curve" feature, to measure ppm, %, or a no unit variable according to a programmable conductivity vs. variable curve. The transmitter automatically recognizes the type of RTD (Pt100 or Pt1000) being used. Measurements are automatically corrected for the resistance of the sensor cable to improve accuracy of high conductivity readings. The Xmt-C provides several temperature compensation algorithms: linear slope, ultra-pure water (neutral salt), or cation conductivity. Alternatively, temperature compensation feature can be turned off to provide display of raw conductivity.

FUNCTIONAL SPECIFICATIONS

Automatic Temperature Compensation:

- 3-wire Pt 100 or Pt 1000 RTD
- Conductivity: 0 to 200°C (32 to 392°F)
- Resistivity: 0 to 100°C (32 to 212°F)
- Low Conductivity: 0 to 100°C (32 to 212°F)

Diagnostics: The internal diagnostics can detect:

- Calibration Error
- Temperature Slope Error
- High Temperature Warning
- Low Temperature Warning
- ROM Failure
- Zero Error
- CPU Failure
- Input Warning

Once one of the above is diagnosed, the Xmt-C will display a message describing the problem.

Digital Communications:

HART: PV, SV, and TV assignable to measurement (conductivity, resistivity, or concentration), temperature, and raw conductivity. Raw conductivity is measured conductivity before temperature correction.

Fieldbus: Three AI blocks assignable to measurement (conductivity, resistivity, or concentration), temperature, and raw conductivity. Raw conductivity is measured conductivity before temperature correction. Execution time 75 msec. One PID block; execution time 150 msec. Device type: 4087. Device revision: 1. Certified to ITK 4.6.

TRANSMITTER SPECIFICATIONS @ 25°C

Measured Range: 0-20,000 µS/cm

Accuracy: ± 0.7% of reading and ± 0.002 µS/cm

Repeatability: ± 0.25% of reading

Temperature Accuracy: ± 0.2°C between 0 and 50°C; ± 0.5°C above 50°C (excludes inaccuracies in sensor)

Temperature Compensation: Slope 0-5%/°C, ultra-pure water, cation conductivity, or raw (uncompensated) conductivity.

Compatible RTD: 100Ω or 1000Ω with automatic recognition

Ambient Temperature Coefficient:
± 0.05% of reading/°C

Maximum Cable Length: 200 ft (61 m)

LOOP SPECIFICATIONS

Accuracy: under controlled laboratory conditions at 25°C (77°F) with perfectly calibrated ENDURANCE sensor of appropriate cell constant:

Cell Constant	Range	Loop accuracy
0.01/cm	up to 50 µS/cm	±0.7% of reading ±0.002 µS/cm
0.1/cm	0.4 to 50 µS/cm 50 to 200 µS/cm	±0.7% of reading ±2% of reading
1.0/cm	4 to 5000 µS/cm 5000 to 20,000 µS/cm	±0.7% of reading ±2% of reading

Calibration: Calibrate against previously calibrated standard sensor and analyzer, or calibrate against solution of known conductivity.

Cell Constant	Suggested Conductivity Range
0.01/cm	up to 50 µS/cm
0.1/cm	0.4 to 500 µS/cm
1.0/cm	4 to 20,000 µS/cm

SENSOR SELECTION GUIDELINES

Note: The conductivity values shown in the above chart are for UNCOMPENSATED (or RAW) conductivity at 25°C. Maximum range values will vary due to temperature compensation selection, process temperature, and other process conditions.

RECOMMENDED SENSORS:

- Model 140 Retractable Conductivity
- Model 141 Insertion High Conductivity
- Model 142 Insertion Low Conductivity
- Model 150 Insertion/Submersion Conductivity
- Model 400/VP Screw-In Low Conductivity
- Model 401 Screw-In High Conductivity
- Model 402/VP Retractable Conductivity
- Model 403/VP Sanitary Conductivity
- Model 404 Low Flow Conductivity

HAZARDOUS LOCATION APPROVALS

Intrinsic Safety(with appropriate safety barrier):



Class I, II, III, Div. 1
Groups A-G
T4 Tamb = 50°C



Class I, II, III, Div. 1
Groups A-G
T4 Tamb = 50°C

ATEX

CE 1180
II 1 G



Baseefa04ATEX0214X
EEx ia IIC T4
Tamb = 0°C to 50°C

Non-Incendive:



Class I, Div. 2, Groups A-D
Dust Ignition Proof
Class II & III, Div. 1, Groups E-G
NEMA 4/4X Enclosure



Class I, Div. 2, Groups A-D
Dust Ignition Proof
Class II & III, Div. 1, Groups E-G
NEMA 4/4X Enclosure
T4 Tamb = 50°C

MODEL Xmt-T TOROIDAL CONDUCTIVITY TRANSMITTER

FEATURES

The Model Xmt-T measures conductivity or % concentration in the harshest environments. Transmitter can also be configured, using the "Custom Curve" feature, to measure ppm, %, or a no unit variable according to a programmable conductivity vs. variable curve. The transmitter recognizes the type of RTD (Pt100 or Pt1000) being used. Measurements are automatically corrected for the resistance of the sensor cable to improve accuracy of high conductivity readings. The Xmt-T is preprogrammed with several concentration curves: 0-12% NaOH, 0-15% HCl, 0-20% NaCl, and 0-25% and 96-99.7% H₂SO₄. Temperature compensation choices are linear slope correction or none (to provide display of raw conductivity).

FUNCTIONAL SPECIFICATIONS

Automatic Temperature Compensation:

- 3-wire Pt 100 RTD or Pt 1000 RTD
- Conductivity: 0 to 200°C (32 to 392°F)
- % Concentration: 0 to 100°C (32 to 212°F)

Diagnostics: The internal diagnostics can detect:

- | | |
|--------------------------|---------------|
| Calibration Error | ROM Failure |
| Temperature Slope Error | Zero Error |
| High Temperature Warning | CPU Failure |
| Low Temperature Warning | Input Warning |

Once one of the above is diagnosed, the LCD will display a message describing the problem.

Digital Communications:

HART: PV, SV, and TV assignable to measurement (conductivity, resistivity, or concentration), temperature, and raw conductivity. Raw conductivity is measured conductivity before temperature correction.

Fieldbus: Three AI blocks assignable to measurement (conductivity, resistivity, or concentration), temperature, and raw conductivity. Raw conductivity is measured conductivity before temperature correction. Execution time 75 msec. One PID block; execution time 150 msec. Device type: 4087. Device revision: 1. Certified to ITK 4.6.

TRANSMITTER SPECIFICATIONS @ 25°C

Measured Range: 50 to 2,000,000 µS/cm (see chart)

Repeatability: ± 0.25% of reading

Temperature Accuracy:

- ± 0.2°C between 0 and 50°C
- ± 0.5°C above 50°C
- (excludes inaccuracies in sensor)

Temperature Slope Adjustment: 0-5%/° C

% Concentration Ranges:

- Sodium Hydroxide: 0 to 12%
- Hydrochloric Acid: 0 to 15%
- Sulfuric Acid: 0 to 25% and 96.0 to 99.7%
- Sodium Chloride: 0 to 20%

Ambient Temperature Coefficient:

± 0.1% of reading ±2µS/cm per °C

Maximum Cable Length: 100 ft (30 m)

LOOP SPECIFICATIONS

Loop Accuracy: With a standard Model 228 or 225 sensor with 20' cable, following a single point calibration, laboratory accuracy at 25°C can be as good as ±2% of reading and ±50 µS/cm.

For optimum performance, standardize the sensor in the process at the conductivity and temperature of interest.

Results under real process conditions, at different temperatures, or using other sensors may differ from above.

Calibration: Calibrate against previously calibrated standard sensor and analyzer, or calibrate against solution of known conductivity.

RECOMMENDED SENSORS:

- | | |
|-----------|----------------------------------|
| Model 222 | Flow-Through |
| Model 225 | Clean-In-Place (CIP) |
| Model 226 | Submersion/Insertion |
| Model 228 | Submersion/Insertion/Retractable |
| Model 242 | Flow-Through |
| Model 245 | Sanitary Flow-Through |
| Model 247 | Submersion/Flow-Tee |

HAZARDOUS LOCATION APPROVALS

Intrinsic Safety (with appropriate safety barrier):



Class I, II, III, Div. 1
Groups A-G
T4 Tamb = 50°C



Class I, II, III, Div. 1
Groups A-G
T4 Tamb = 50°C

ATEX



CE 1180
II 1 G
Baseefa04ATEX0215X
EEx ia IIC T4
Tamb = 0°C to 50°C

Non-Incendive:



Class I, Div. 2, Groups A-D
Dust Ignition Proof
Class II & III, Div. 1, Groups E-G
NEMA 4/4X Enclosure



Class I, Div. 2, Groups A-D
Dust Ignition Proof
Class II & III, Div. 1, Groups E-G
NEMA 4/4X Enclosure
T4 Tamb = 50°C

RECOMMENDED RANGES FOR TOROIDAL SENSORS

Conductivity Sensor Model	226	228	225	222 (1in.)	222 (2 in.)	242	245	247
Nominal Cell Constant	1.0	3.0	3.0	6.0	4.0	*	*	3.5
Minimum Conductivity (µS/cm)	50	200	200	500	500	100*	100*	500
Maximum Conductivity (µS/cm)	1,000,000	2,000,000	2,000,000	2,000,000	2,000,000	2,000,000*	2,000,000	2,000,000

* Model 242 values depend on sensor configuration and wiring.

Values shown are for 25°C conductivity with a temperature slope of 2% per degree C. The maximum range value will be lower for solutions with a higher temperature slope. Minimum conductivity depends on sensor.

TYPICAL MAIN SCREEN DISPLAYS:

Xmt-P

pH

12.34	pH
26.3°C	16.78mA

to show impedance:

12.34	pH	26.3°C
G: 1234MΩ	R: 123kΩ	

Xmt-C

Conductivity

12.34	µS/cm
26.3°C	16.78mA

Xmt-T:

Percent Concentration

12.34	%
26.3°C	16.78mA

Xmt-A

Free chlorine with pH correction

1.234	PPM
26.3°C	16.78mA

Easy-to-use menus guide you through every step of the programming. Here's how easy it is to calibrate a chlorine sensor:

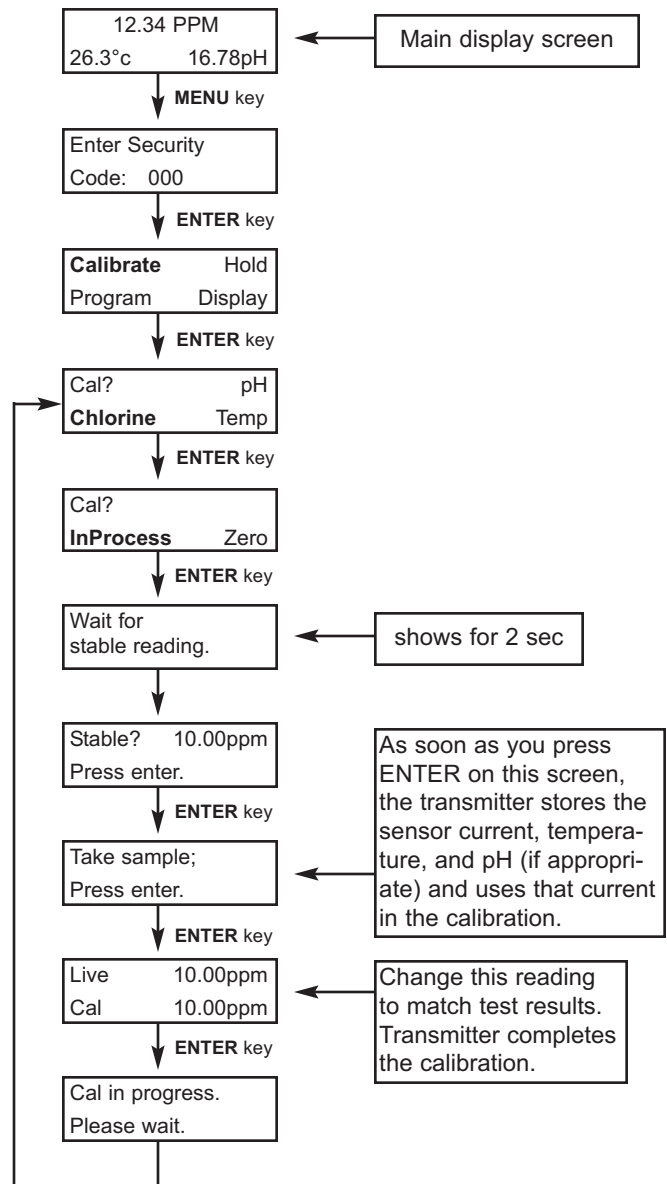

FOUNDATION FIELDBUS (FIGURE 1)

Figure 1 shows a Xmt-A-FF being used to measure and control pH and chlorine levels in drinking water. The figure also shows three ways in which fieldbus communication can be used to read process variables and configure the transmitter.

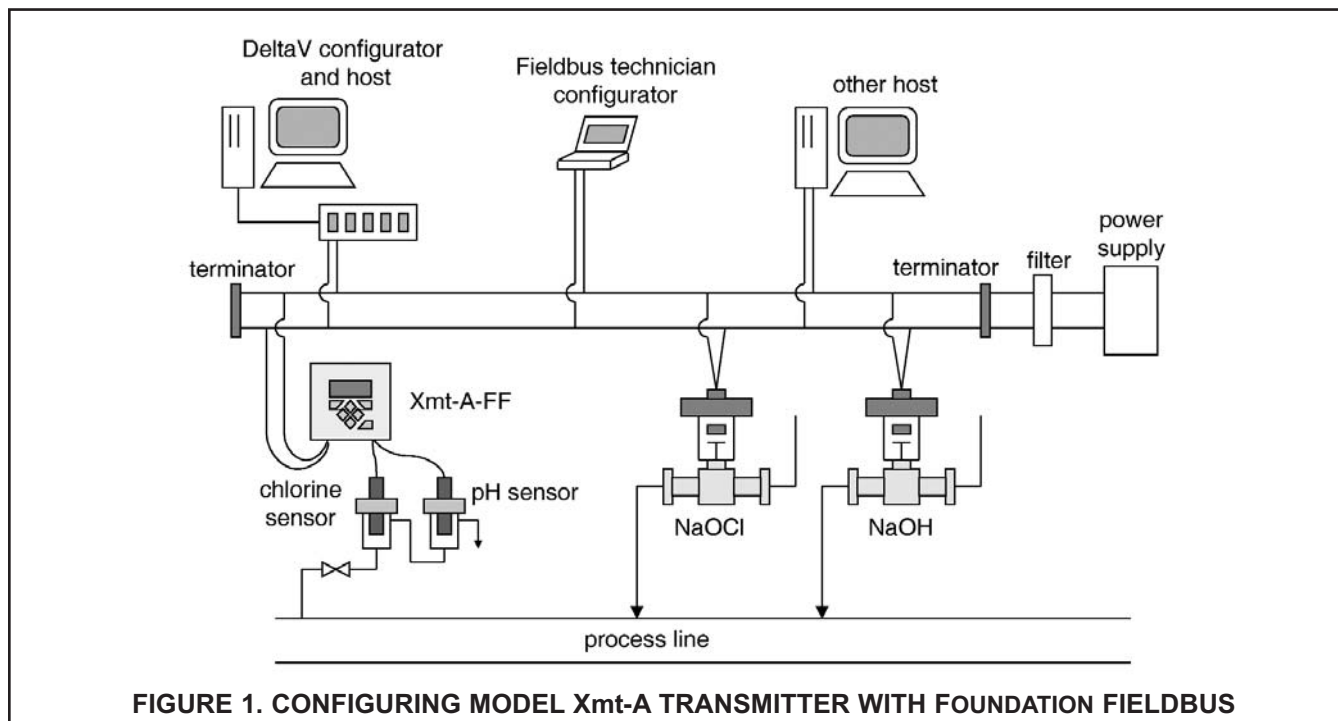

FIGURE 1. CONFIGURING MODEL Xmt-A TRANSMITTER WITH FOUNDATION FIELDBUS

ASSET MANAGEMENT SOLUTIONS (AMS) (FIGURES 2, 3, & 4)

Rosemount Analytical AMS windows provide access to all transmitter measurement and configuration variables. The user can read raw data, final data, and program settings and can reconfigure the transmitter from anywhere in the plant. Figures 2 and 3 show two of the many configuration and measurement screens available using HART AMS. Figure 4 shows a configuration screen available through AMS Inside using FOUNDATION fieldbus.

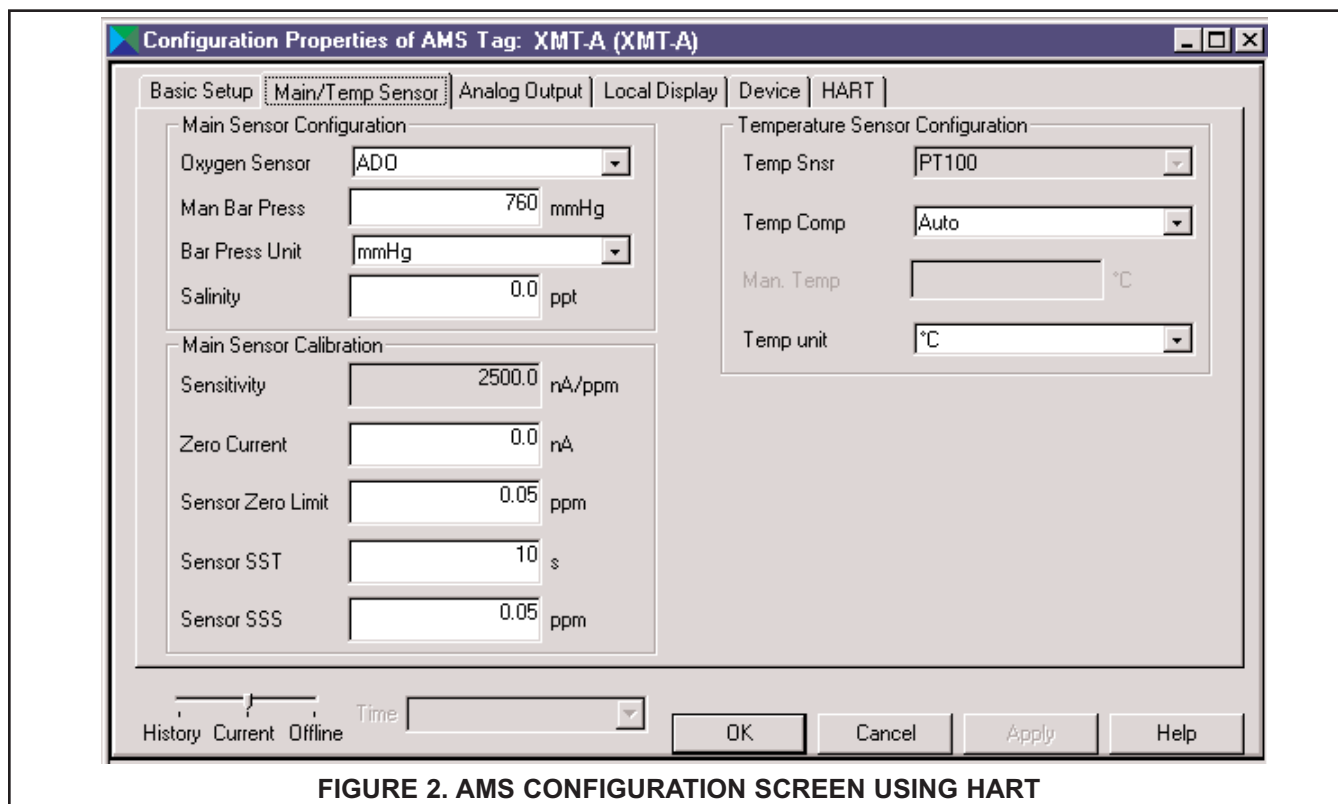

FIGURE 2. AMS CONFIGURATION SCREEN USING HART

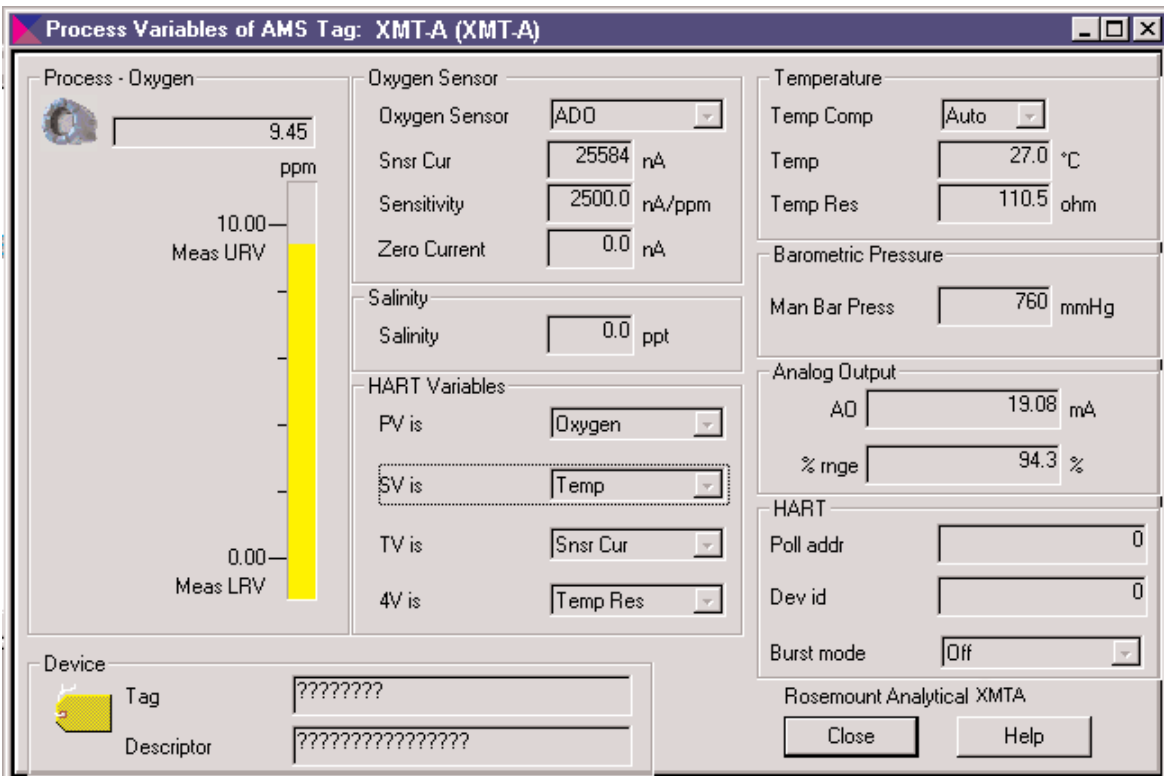

FIGURE 3. AMS MEASUREMENT SCREEN USING HART

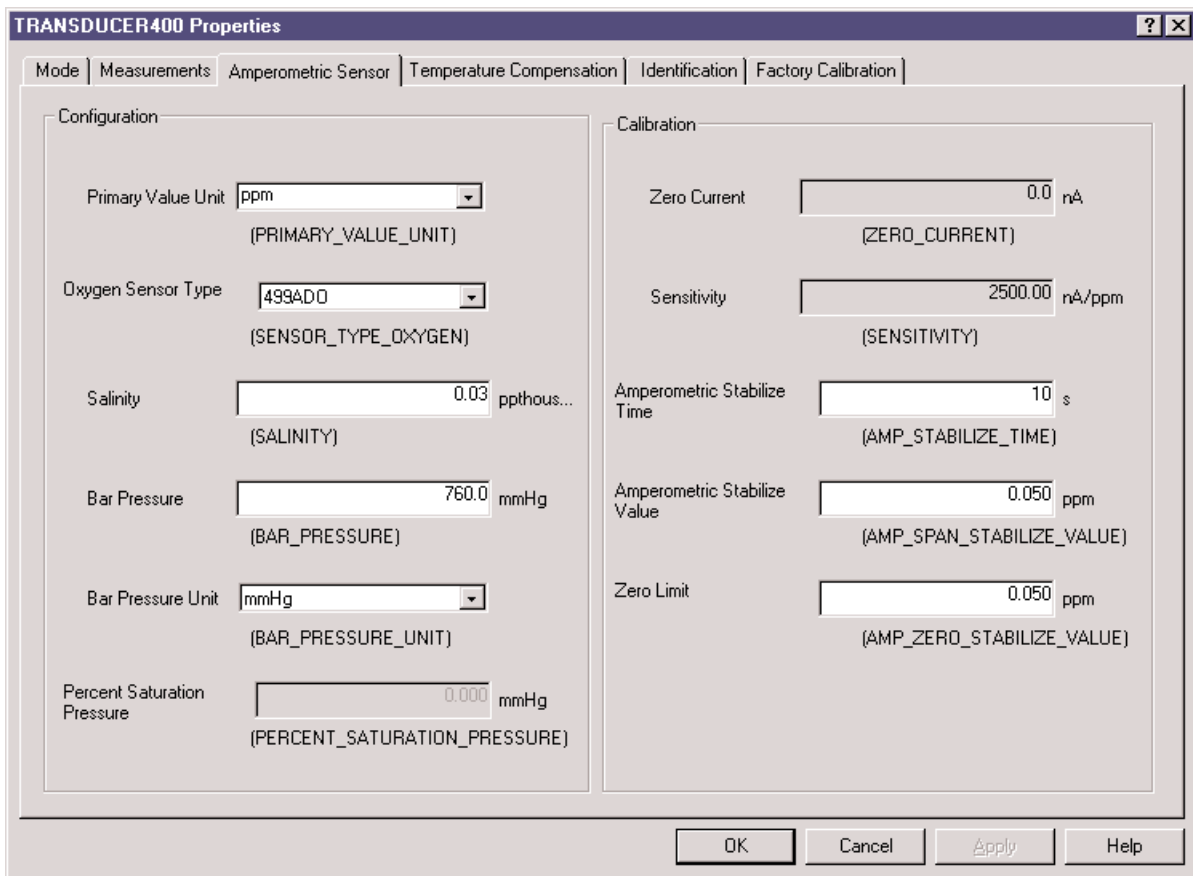
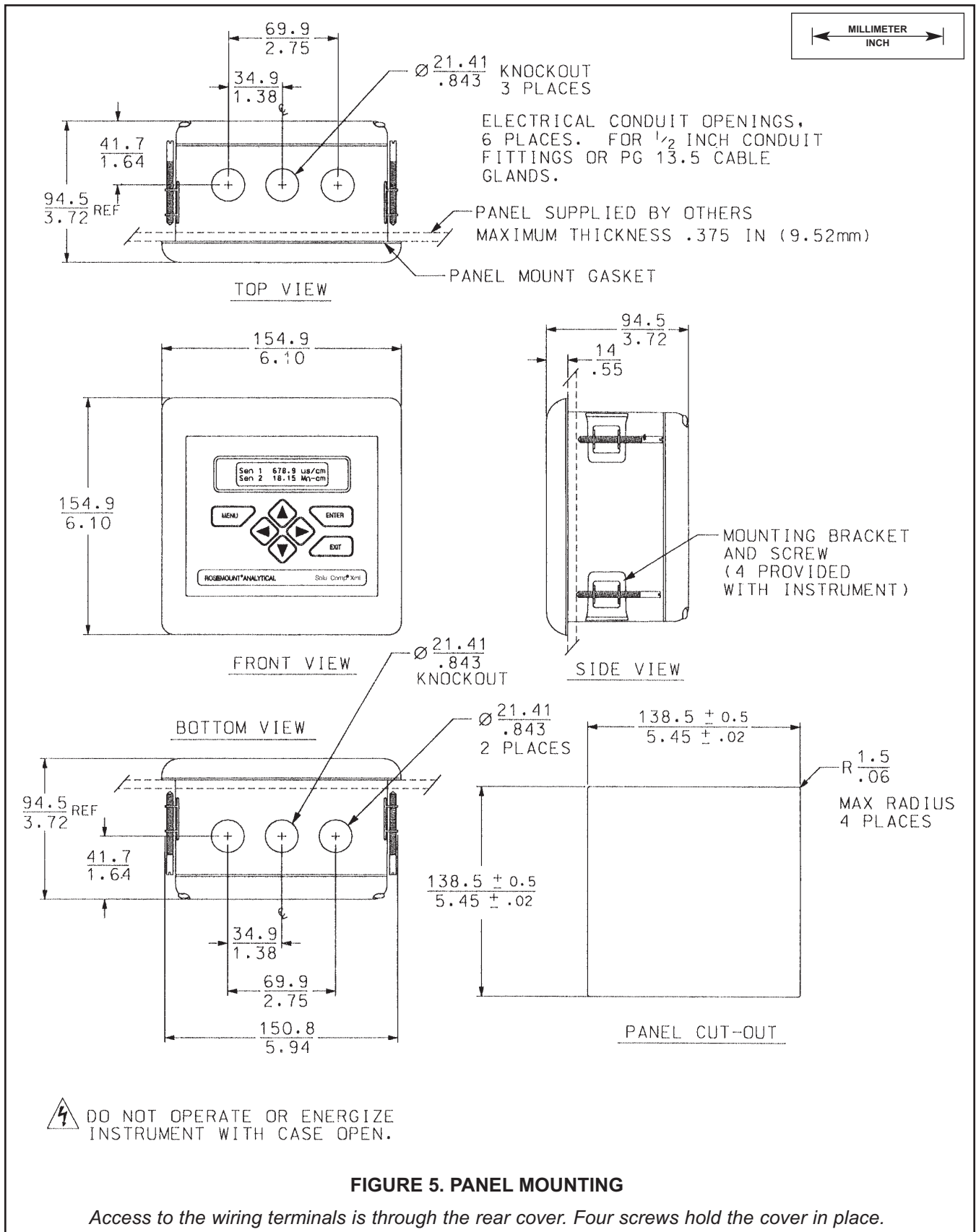

FIGURE 4. AMS INSIDE CONFIGURATION SCREEN USING FOUNDATION FIELDBUS



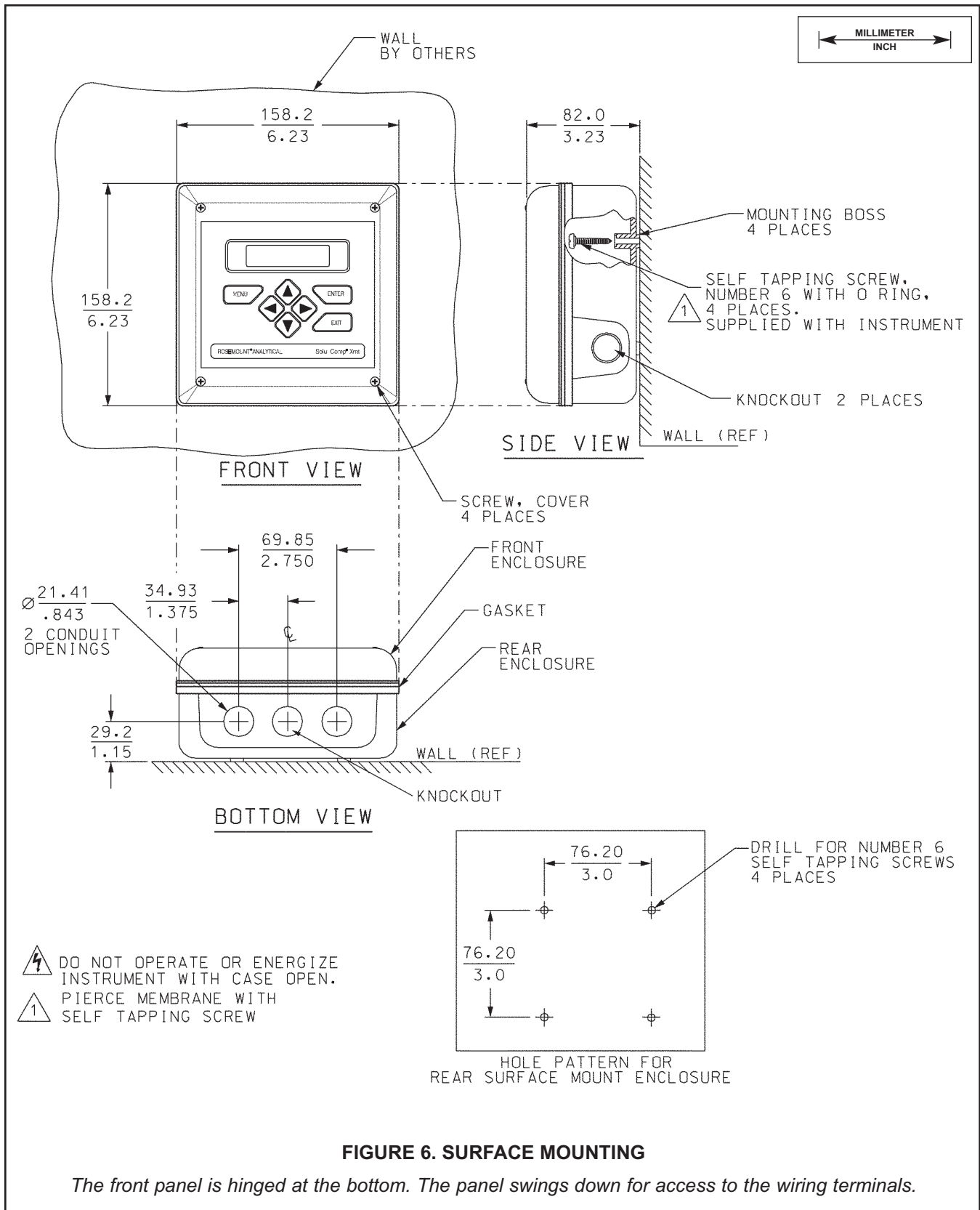
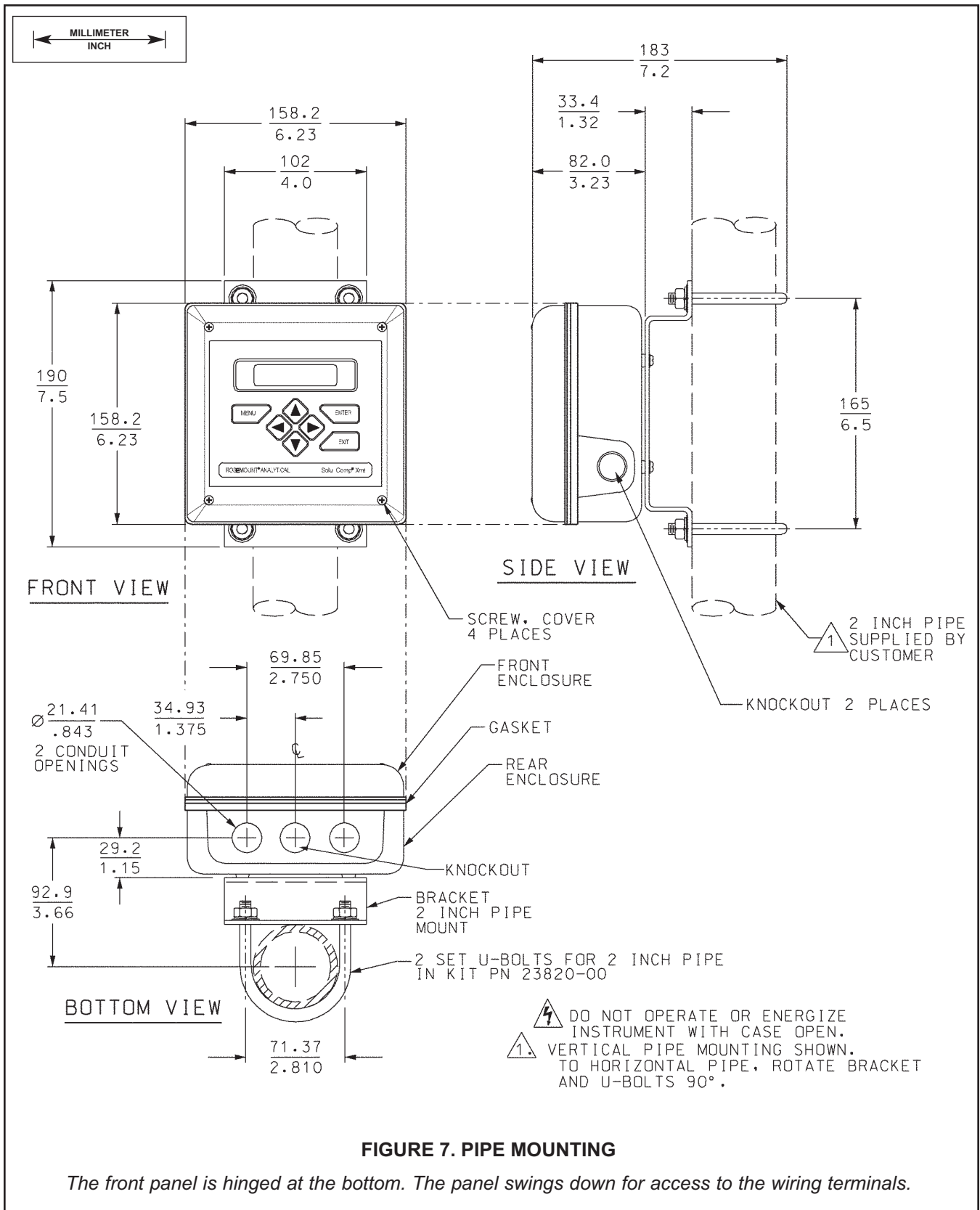

FIGURE 6. SURFACE MOUNTING

The front panel is hinged at the bottom. The panel swings down for access to the wiring terminals.



ORDERING INFORMATION

The **Solu Comp Model Xmt Two-Wire Transmitter** is intended for the determination of pH/ORP, conductivity (both contacting and toroidal), and for measurements using membrane-covered amperometric sensors (oxygen, ozone, free and total chlorine, and monochloramine). For free chlorine measurements, which often require continuous pH correction, a second input for a pH sensor is standard.

MODEL Xmt SMART TWO-WIRE MICROPROCESSOR TRANSMITTER	
CODE	REQUIRED SELECTION
P	pH/ORP
C	Contacting conductivity
T	Toroidal conductivity
A	Amperometric (oxygen, ozone, and chlorine)
CODE	REQUIRED SELECTION
HT	Analog 4-20 mA output with superimposed HART digital signal
FF	Foundation fieldbus digital output
FI	Foundation fieldbus digital output with FISCO
CODE	REQUIRED SELECTION
10	Panel mounting enclosure
11	Pipe/Surface mounting enclosure (pipe mounting requires accessory kit PN 23820-00)
CODE	AGENCY APPROVALS
60	No approval
67	FM approved intrinsically safe and non-incendive (when used with appropriate sensor and safety barrier)
69	CSA approved intrinsically safe and non-incendive (when used with appropriate sensor and safety barrier)
73	ATEX approved intrinsically safe (when used with appropriate sensor and safety barrier)
Xmt-P-HT-10-67 EXAMPLE	

ACCESSORIES

MODEL/PN	DESCRIPTION
515	DC loop power supply (see product data sheet 71-515)
230A	Alarm module (see product data sheet 71-230A)
23820-00	2-in. pipe mounting kit
9240048-00	Stainless steel tag, specify marking
23554-00	Gland fittings PG 13.5, 5 per package



*The right people,
the right answers,
right now.*

**ROSEMOUNT ANALYTICAL
CUSTOMER SUPPORT CENTER
1-800-854-8257**



ON-LINE ORDERING NOW AVAILABLE ON OUR WEB SITE
<http://www.raihome.com>

Specifications subject to change without notice.



Credit Cards for U.S. Purchases Only.



Emerson Process Management

Liquid Division

2400 Barranca Parkway
Irvine, CA 92606 USA
Tel: (949) 757-8500
Fax: (949) 474-7250

<http://www.raihome.com>