

Solid State Relays Industrial, 1-Phase ZS (IO) w. LED Types RAM1A, RAM1B

CARLO GAVAZZI



- Zero switching (RAM1A) or instant-on switching (RAM1B) AC Solid State Relay
- Direct copper bonding (DCB) technology
- LED indication
- Clip-on IP 20 protection cover
- Self-lifting terminals
- Housing free of moulding mass
- 2 input ranges: 3-32 VDC* and 20-280 VAC/22-48 VDC
- Operational ratings up to 125 AACrms and 600 VACrms
- Non-repetitive voltage: Up to 1200 V_p
- Opto-insulation: > 4000 VACrms
- Integrated overvoltage protection by self switching (suffix "Z" option)

Product Description

The industrial, 1-phase relay with antiparallel thyristor output is the most widely used industrial SSR due to its multiple application possibilities. The relay can be used for resistive, inductive and capacitive loads. The zero switching relay switches ON when the sinusoidal curve crosses zero and switches OFF when the current cross-

es zero. The instant-on relay with DC control input can be used for phase angle control. The built-in snubber secures transient protection. The LED indicates the status of the control input. The clip-on cover secures touch protection (IP 20). Protected output terminals can handle cables up to 16 mm².

Ordering Key

RAM 1 A 60 D 125 Z

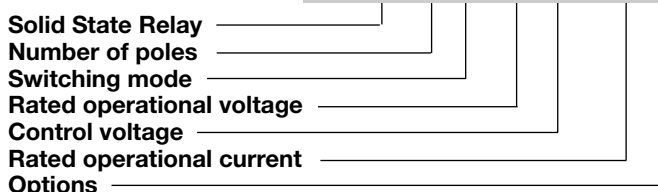

Type Selection

Switching mode	Rated operational voltage	Control voltage	Rated operational current	Options
A: Zero Switching B: Instant-on switching	23: 230 VACrms 60: 600 VACrms	A: 20-280 VAC/22-48 VDC D: 3 - 32 VDC* * 4 to 32 VDC for 600 VAC types	25 : 25 AACrms 50 : 50 AACrms 75 : 75 AACrms 100:100 AACrms 125:125 AACrms	Z: Overvoltage protection (self-switching)

Selection Guide

Rated operational voltage	Non-rep. voltage	Control voltage	Rated operational current				
			25 A	50 A	75 A	100 A	125 A
230 VACrms	650 V _p	3 - 32 VDC 20-280 VAC/22-48 VDC	RAM1A23D25	RAM1A23D50	RAM1A23D75	RAM1A23D100	RAM1A23D125
			RAM1A23A25	RAM1A23A50	RAM1A23A75	RAM1A23A100	RAM1A23A125
600 VACrms	1200 V _p	4 - 32 VDC 20-280 VAC/22-48 VDC	RAM1A60D25	RAM1A60D50	RAM1A60D75	RAM1A60D100	RAM1A60D125
			RAM1A60A25	RAM1A60A50	RAM1A60A75	RAM1A60A100	RAM1A60A125

Options

- 1 Overvoltage protection by self-switching: add suffix Z to include. Example: RAM1A60D25Z
- 2 690 VACrms rated operational voltage available on request for 75A, 100A and 125A types. Example: RAM1A69D75

General Specifications

	RAM1.23..	RAM1.60..
Operational voltage range	24 to 265 VACrms	24 to 660 VACrms
Non-rep. peak voltage	$\geq 650 V_p$	$\geq 1200 V_p$
Zero voltage turn-on	$\leq 10 V$	$\leq 10 V$
Operational frequency range	45 to 65 Hz	45 to 65 Hz
Power factor	$> 0.5 @ 230 VACrms$	$> 0.5 @ 600 VACrms$
Approvals	UL, cUL, CSA*, VDE**	UL, cUL, CSA*, VDE**
CE-marking	Yes	Yes

* Approval pending ** VDE0805

Input Specifications

	RAM1...D..	RAM1...A..
Control voltage range		
RAM1.23.	3-32 VDC	20-280VAC, 22-48 VDC
RAM1.60.	4-32 VDC	20-280VAC, 22-48 VDC
Pick-up voltage		
RAM1.23.	2.5 VDC	18 VAC/DC
RAM1.60.	3.5 VDC	18 VAC/DC
Reverse voltage	$\leq 32 VDC$	-
Drop out voltage	$\leq 1.2 VDC$	$\leq 6 VAC/DC$
Input current @ max input voltage	$\leq 12 mA$	$\leq 20 mA$
Response time pick-up		$\leq 12ms$
RAM1A	$\leq 1/2$ cycle	
RAM1B	$\leq 0.1 ms$	
Response time drop-out	$\leq 1/2$ cycle	$\leq 40ms$

Output Specifications

	RAM1...25	RAM...50	RAM1...75	RAM1...100	RAM...125
Rated operational current					
AC51 @ Ta=25°C	25 Arms	50 Arms	75 Arms	100 Arms	125 Arms
AC53a @ Ta=25°C	5 Arms	15 Arms	17 Arms	20 Arms	30 Arms
Min. operational current	150 mA	150 mA	150 mA	150 mA	150mA
Rep. overload current t=1 s	$< 55 AACrms$	$< 125 AACrms$	$< 130 AACrms$	$< 150 AACrms$	$< 200 AACrms$
Non-rep. surge current t=10 ms	250 A _p	600 A _p	800 A _p	1000 A _p	1500A _p
Off-state leakage current @ rated voltage and frequency	$< 3 mArms$	$< 3 mArms$	$< 3 mArms$	$< 3 mArms$	$< 3 mArms$
I _t for fusing t= 1-10 ms	$< 310 A^2s$	$< 1800 A^2s$	$< 3200 A^2s$	$< 6600 A^2s$	$< 18000 A^2s$
Critical di/dt	$\geq 100 A/\mu s$	$\geq 100 A/\mu s$	$\geq 100 A/\mu s$	$\geq 100 A/\mu s$	$\geq 100 A/\mu s$
On-state voltage drop	$\leq 1.6 Vrms$	$\leq 1.6 Vrms$	$\leq 1.6 Vrms$	$\leq 1.6 Vrms$	$\leq 1.6 Vrms$
Critical dV/dt off-state min.	1000 V/ μs	1000 V/ μs	1000 V/ μs	1000 V/ μs	1000 V/ μs

Thermal Specifications

Operating temperature	-40° to +80°C (-40° to +176°F)
Storage temperature	-40° to +100°C (-40° to +212°F)
Junction temperature	$\leq 125^\circ C$ (257°F)

Insulation

Rated insulation voltage	
Input to output	$\geq 4000 VACrms$
Output to case	$\geq 4000 VACrms$

Housing Specifications

Weight 25 A, 50 A 75 A, 100 A, 125 A	Approx. 60 g Approx. 100 g	Relay Mounting screws Mounting torque	M5 1.5-2.0 Nm
Housing material	Noryl, black	Control terminal Mounting screws Mounting torque	M3 x 9 0.5 Nm
Baseplate 25 A, 50 A 75 A, 100 A, 125 A	Aluminium Copper, nickel-plated	Power terminal Mounting screws Mounting torque	M5 x 9 2.4 Nm

Functional Diagram

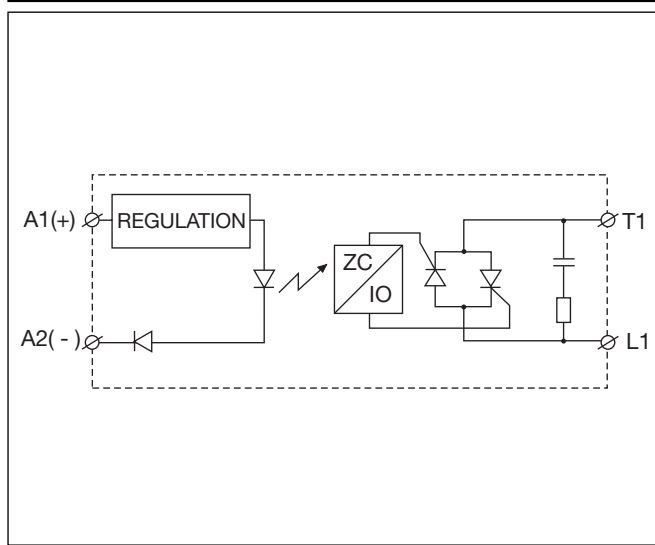

Dimensions

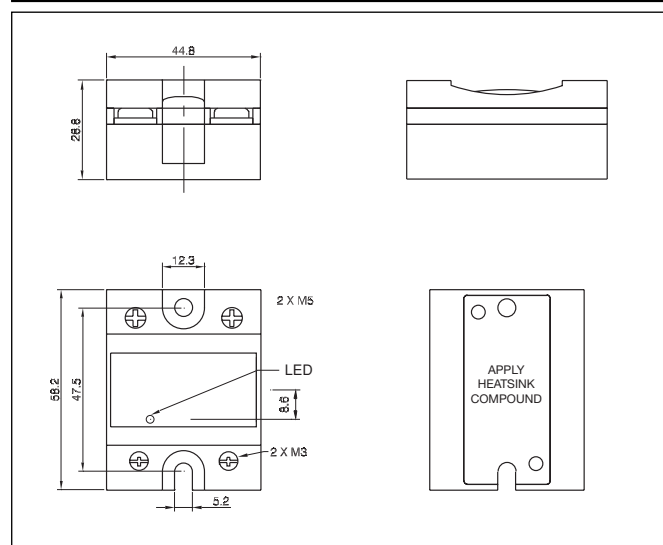

Heatsink Dimensions (load current versus ambient temperature)

RAM..25

Load current [A]	Thermal resistance [K/W]						Power dissipation [W]
	20	30	40	50	60	70	
25.0	3.23	2.80	2.37	1.94	1.51	1.09	23
22.5	3.70	3.21	2.73	2.24	1.75	1.26	21
20.0	4.30	3.74	3.17	2.61	2.05	1.49	18
17.5	5.07	4.41	3.76	3.10	2.44	1.78	15
15.0	6.12	5.33	4.54	3.75	2.96	2.17	13
12.5	7.58	6.61	5.64	4.66	3.69	2.72	10
10.0	9.80	8.55	7.30	6.05	4.80	3.55	8
7.5	13.5	11.80	10.09	8.37	6.66	4.94	6
5.0	-	18.3	15.7	13.04	10.39	7.74	4
2.5	-	-	-	-	-	16.2	2

Ambient temp. [°C]

RAM..50

Load current [A]	Thermal resistance [K/W]						Power dissipation [W]
	20	30	40	50	60	70	
50.0	1.25	1.07	0.88	0.70	0.52	0.34	55
45.0	1.46	1.25	1.04	0.84	0.63	0.42	48
40.0	1.73	1.49	1.25	1.01	0.77	0.52	41
35.0	2.08	1.80	1.51	1.23	0.94	0.66	35
30.0	2.56	2.22	1.87	1.53	1.18	0.84	29
25.0	3.24	2.81	2.38	1.95	1.52	1.09	23
20.0	4.26	3.71	3.15	2.59	2.03	1.47	18
15.0	5.99	5.22	4.45	3.67	2.90	2.12	13
10.0	9.49	8.27	7.06	5.85	4.64	3.43	8
5.0	-	17.5	15.0	12.4	9.91	7.39	4

Ambient temp. [°C]



Heatsink Dimensions (cont.)

RAM..75

Load current [A]	Thermal resistance [K/W]						Power dissipation [W]
	20	30	40	50	60	75	
75.0	0.94	0.82	0.70	0.58	0.47	0.29	85
67.5	1.10	0.96	0.82	0.69	0.55	0.34	73
60.0	1.30	1.14	0.98	0.81	0.65	0.41	61
52.5	1.57	1.38	1.18	0.98	0.79	0.49	51
45.0	1.95	1.70	1.46	1.22	0.97	0.61	41
37.5	2.48	2.17	1.86	1.55	1.24	0.78	32
30.0	3.32	2.90	2.49	2.07	1.66	1.04	24
22.5	4.75	4.15	3.56	2.97	2.37	1.48	17
15.0	7.68	6.72	5.76	4.80	3.84	2.40	10
7.5	-	14.59	12.50	10.42	8.34	5.21	5

Ambient temp. [°C]

RAM..100

Load current [A]	Thermal resistance [K/W]						Power dissipation [W]
	20	30	40	50	60	70	
100.0	0.60	0.52	0.43	0.34	0.26	0.17	117
90.0	0.74	0.64	0.54	0.44	0.34	0.24	101
80.0	0.91	0.79	0.68	0.56	0.45	0.33	87
70.0	1.09	0.96	0.82	0.68	0.55	0.41	73
60.0	1.33	1.16	1.00	0.83	0.66	0.50	60
50.0	1.66	1.45	1.24	1.04	0.83	0.62	48
40.0	2.16	1.89	1.62	1.35	1.08	0.81	37
30.0	3.01	2.64	2.26	1.88	1.51	1.13	27
20.0	4.73	4.14	3.55	2.96	2.37	1.78	17
10.0	9.94	8.70	7.45	6.21	4.97	3.73	8

Ambient temp. [°C]

RAM..125

Load current [A]	Thermal resistance [K/W]						Power dissipation [W]
	20	30	40	50	60	70	
125.0	0.63	0.55	0.47	0.40	0.32	0.24	126
112.5	0.73	0.64	0.54	0.45	0.36	0.27	110
100.0	0.84	0.74	0.63	0.53	0.42	0.32	95
87.5	0.99	0.87	0.74	0.62	0.50	0.37	81
75.0	1.20	1.05	0.90	0.75	0.60	0.45	67
62.5	1.48	1.30	1.11	0.93	0.74	0.56	54
50.0	1.92	1.68	1.44	1.20	0.96	0.72	42
37.5	2.65	2.32	1.98	1.65	1.32	0.99	30
25.0	4.12	3.60	3.09	2.57	2.06	1.54	19
12.5	8.55	7.48	6.41	5.34	4.27	3.21	9

Ambient temp. [°C]

Heatsink Selection

Carlo Gavazzi Heatsink (see Accessories)	Thermal resistance...	for power dissipation
No heatsink required	---	N/A
RHS 300	5.00 K/W	> 0 W
RHS 100	3.00 K/W	> 25 W
RHS 45A	2.70 K/W	> 55 W
RHS 45B	2.00 K/W	> 60 W
RHS 90	1.35 K/W	> 60 W
RHS 45A plus fan	1.25 K/W	> 0 W
RHS 45B plus fan	1.20 K/W	> 0 W
RHS 112	1.10 K/W	> 100 W
RHS 301	0.80 K/W	> 80 W
RHS 90 plus fan	0.45 K/W	> 0 W
RHS 112 plus fan	0.40 K/W	> 0 W
RHS 301 plus fa	0.25 K/W	> 0 W
Consult your distribution	> 0.25 K/W	N/A
Infinite heatsink - No solution	---	N/A