

Rosemount™ 499ATrDO

Trace Dissolved Oxygen Sensor



Safety information

CAUTION!

SENSOR/PROCESS APPLICATION COMPATIBILITY

The wetted sensor material may not be compatible with process composition and operating conditions. Application compatibility is entirely your responsibility.

CAUTION!

EQUIPMENT DAMAGE

Do not exceed pressure and temperature specifications.

Pressure: 65 psig (549 kPa abs) max. Temperature: 32 to 122 °F (0 to 50 °C)

Contents

Chapter 1	Plan	1
	1.1 Unpacking and inspection	1
	1.2 Product description	1
	1.3 Specifications	1
Chapter 2	Install	5
Chapter 3	Wire	7
Chapter 4	Calibrate	15
	4.1 Zero point calibration	15
	4.2 Full scale	15
Chapter 5	Maintenance	17
	5.1 Cleaning the membrane	17
	5.2 Replacing the electrolyte solution and membrane	17
	5.3 Storage	19
Chapter 6	Accessories	21

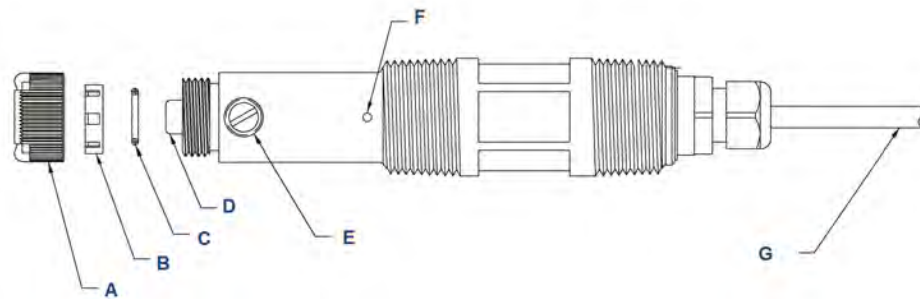
1 Plan

1.1 Unpacking and inspection

1. Inspect the shipping container. If it is damaged, contact the shipper immediately for instructions.
2. Save the box.
3. If there is no apparent damage, unpack the container. Be sure all items shown on the packing list are present. If items are missing, notify Rosemount immediately.

1.2 Product description

Figure 1-1: Rosemount 499ATrDO Sensor Parts



- A. Membrane retainer
- B. Membrane assembly
- C. O-ring
- D. Cathode
- E. Electrolyte fill plug (wrap with pipe tape)
- F. Pressure equalizing port
- G. Sensor cable (integral cable shown)

1.3 Specifications

Table 1-1: Sensor specifications

Physical characteristics	Specifications
Range	0.1 ppb to 20 ppm
Pressure	0 to 65 psig (101 to 549 kPa abs)
Temperature (operating)	0 to 50 °C (32 to 122 °F)

Table 1-1: Sensor specifications (continued)

Physical characteristics	Specifications				
Process connection	1 in. MNPT				
Wetted parts	Noryl ^{®(1)} , Viton, EPDM, Teflon ^{®(2)} , and silicone				
Cathode	Gold (not normally wetted)				
Accuracy	Accuracy depends on the accuracy of the chemical test used to calibrate the sensor.				
Linearity	±5% of reading or ±3 ppb (whichever is greater) at 77 °F (25 °C)				
Repeatability	±2% of reading at constant temperature				
Response time	< 20 sec to 90% of final reading at 25 °C (77 °F) (0 to 200 ppb oxygen)				
Membrane permeability connection	Defined between 41 and 95 °F (0 and 50 °C)				
Process connection	1 in. MNPT				
Electrolyte volume	25 mL (approx.)				
Electrolyte life	4 to 6 months (approx.)				
Sensor life	2 years (approx.)				
Accuracy at 77 °F (25 °C) following air calibration	<table border="1"> <tbody> <tr> <td><20 ppb</td> <td>±1 ppb</td> </tr> <tr> <td>>20 ppb</td> <td>±5% of reading</td> </tr> </tbody> </table>	<20 ppb	±1 ppb	>20 ppb	±5% of reading
<20 ppb	±1 ppb				
>20 ppb	±5% of reading				
Cable length (standard integral cable)	25 ft (7.6 m)				
Cable length (maximum)	300 ft (91 m)				
Drift	<4% over 60 days				
Sample flow	1.6-6.3 gph (100-400 mL/min) recommended. Response changes less than 2% when flow is maintained at recommended range. At 0.8 gph (50 mL/min), sensor response is about 90% of value at 100 mL/min.				
Process connections	Sensor must be used in flow cell PN 24091-01				
Comedown time to 1 ppb	New sensor: < 5 hours Following membrane change: < 1 hour Following air calibration: < 1 hour				
Shelf life	3 months. If the shelf life has been exceeded, the sensor can still be used. The comedown time will be longer.				
Weight/shipping weight	1 lb/3 lb (0.5kg /1.5 kg)				

(1) Noryl is a registered trademark of General Electric.

(2) Viton and Teflon are registered trademarks of E.I. duPont de Nemours & Co.

Table 1-2: Other specifications

Type	PN	Wetted materials	Process connection	Maximum temperature	Maximum pressure
Low flow cell ⁽¹⁾	24091-00	Polycarbonate/polyester, 316 stainless steel, and silicone	Compression fitting for 1/4 in. O.D. tubing or 1/4 in. FNPT	158 °F (70 °C)	90 psig (722 kPa abs)

(1) Temperature and pressure specifications for the low flow cell exceed the temperature and pressure specifications for the sensor.

2 Install

The gray PVC cap contains a solution of sodium sulfite. Remove the cap before installing the sensor.

⚠ WARNING!

POISONOUS SUBSTANCE

The cap contains sodium sulfite solution. Avoid contact with skin or eyes. Do not swallow!

Figure 2-1: Sensor Orientation

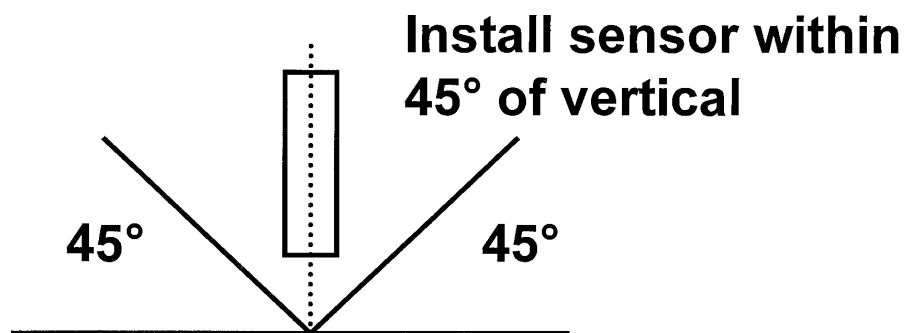
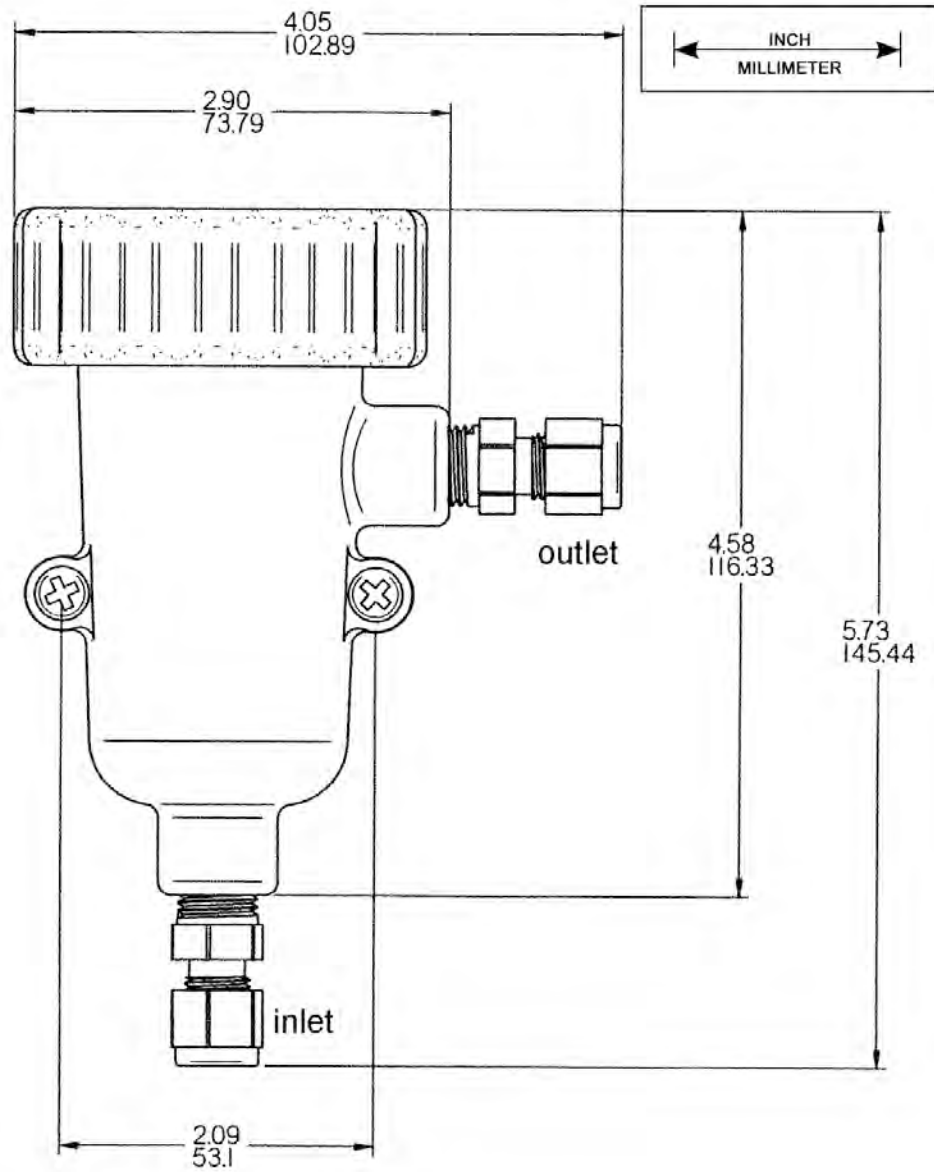


Figure 2-2: Low Flow Cell (PN 24091-00)



3 Wire

NOTICE

For additional wiring information on this product, including sensor combinations not shown here, please refer to the [Liquid Transmitter Wiring Diagrams](#).

Figure 3-1: Rosemount 499ATrDO-54 Sensor Wiring to Rosemount 1056 and 56 Transmitters

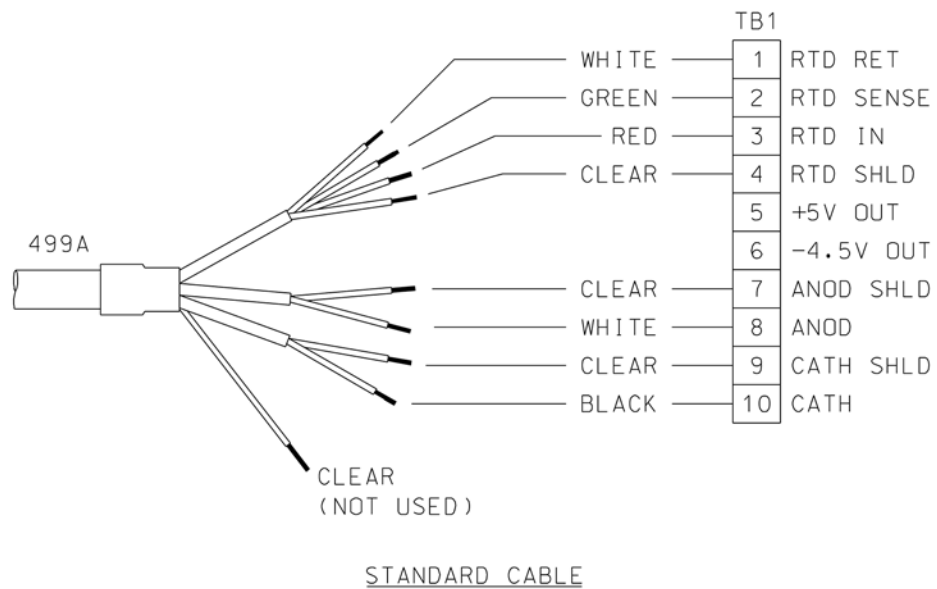
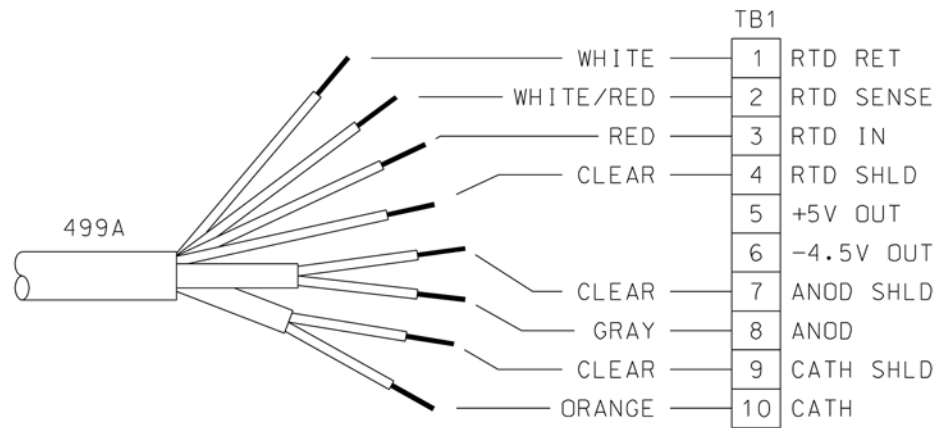


Figure 3-2: Rosemount 499ATrDO-54-60 and 499ATrDO-54-VP Sensor Wiring to Rosemount 1056 and 56 Transmitters



VARIOPOL AND EMI/RFI CABLE

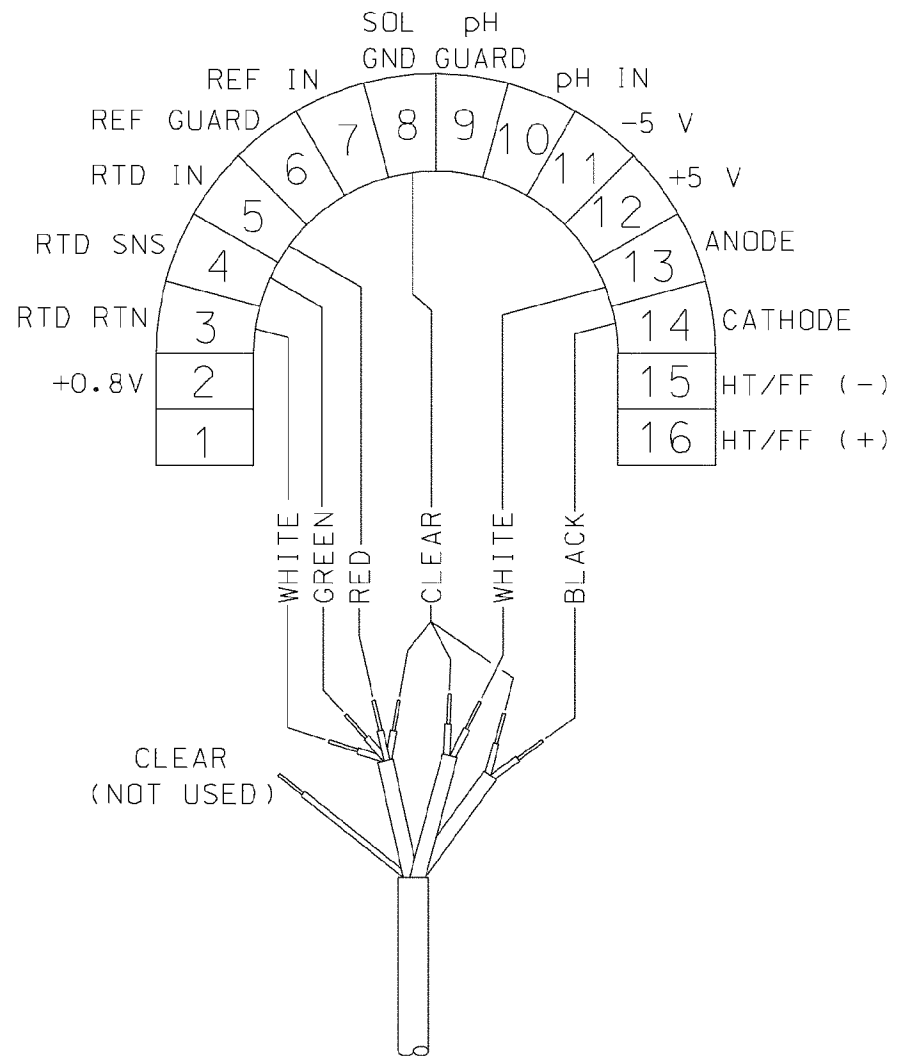
Figure 3-3: Rosemount 499ATrDO-54 Sensor Wiring to Rosemount 5081 transmitter

Figure 3-4: Rosemount 499ATrDO-54-60 and 499ATrDO-54-VP Sensor Wiring to Rosemount 5081 Transmitter

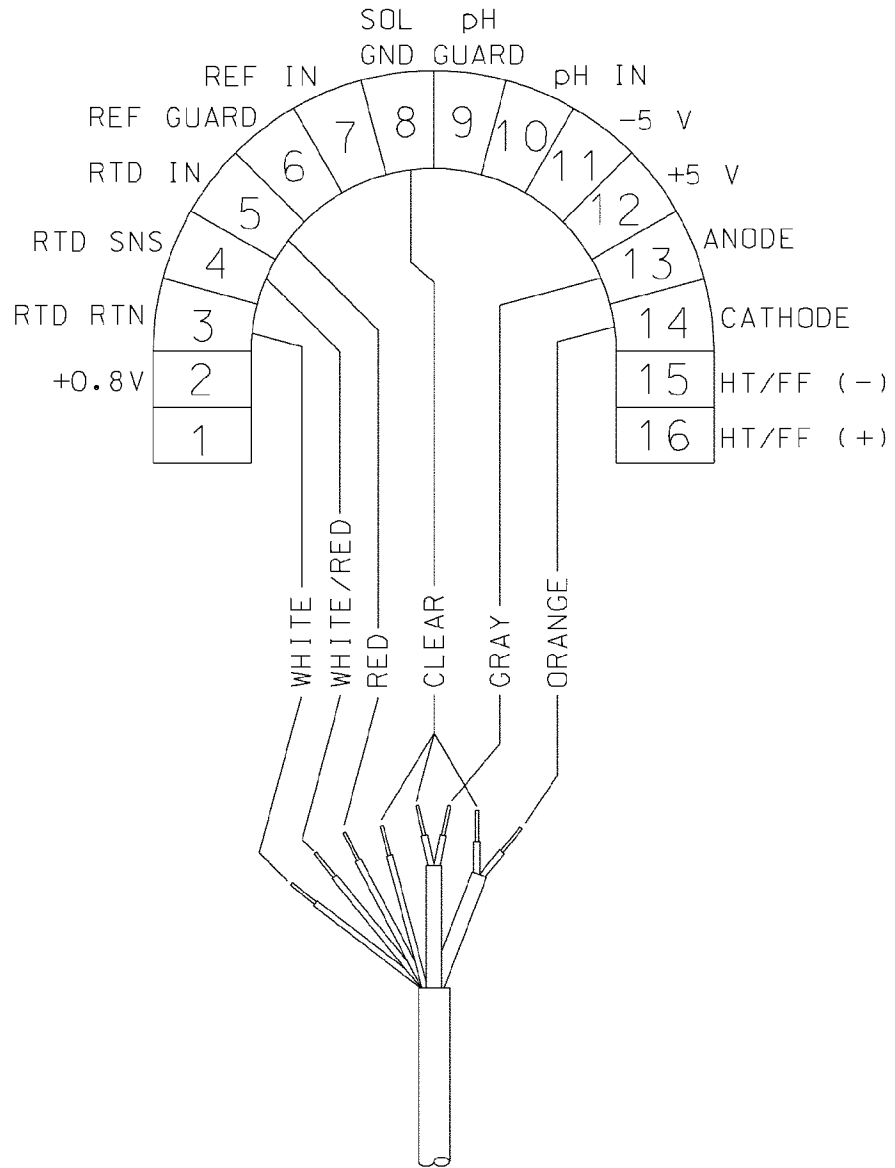
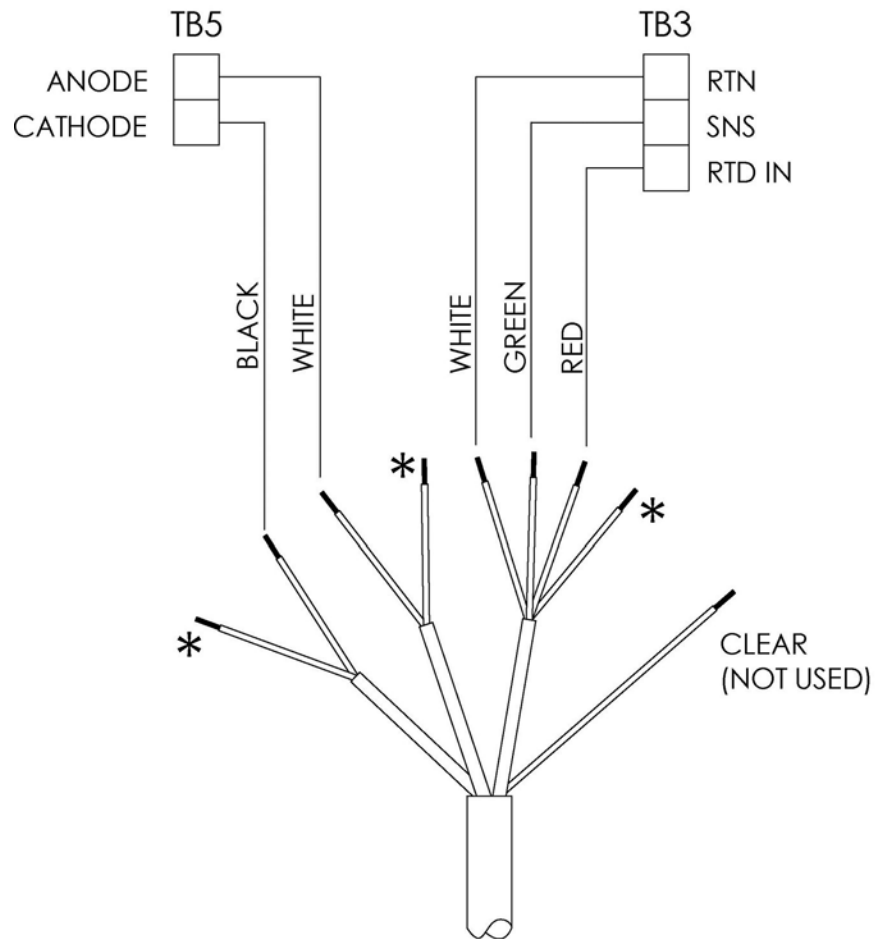
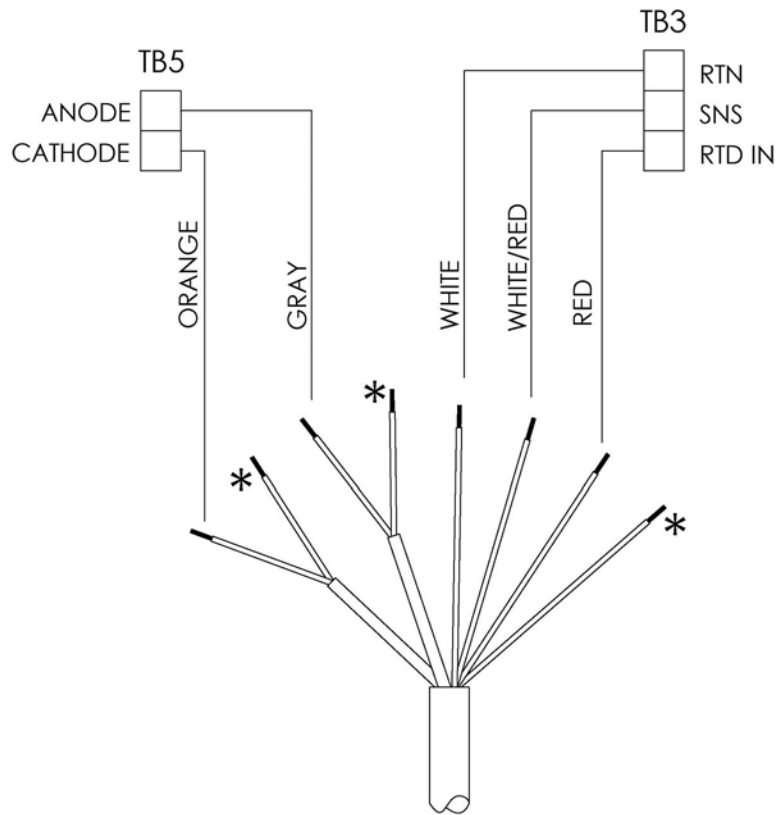


Figure 3-5: Rosemount 499ATrDO-54 Sensor Wiring to Rosemount 1066 Transmitter

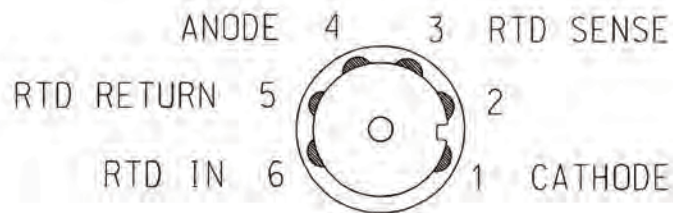
* CONNECT CLEAR SHIELD WIRES TO SOL GND TERMINAL ON TB 2. USE WIRE NUT AND PIGTAIL IF NECESSARY.

Figure 3-6: Rosemount 499ATrDO-54-60 and 499ATrDO-54-VP Sensor Wiring to Rosemount 1066 Transmitter



* CONNECT CLEAR SHIELD WIRES TO SOL GND TERMINAL ON TB 2. USE WIRE NUT AND PIGTAIL IF NECESSARY.

Figure 3-7: Rosemount 499ATrDO Sensor Pin-out Diagram (Top View of Connector End of Sensor)



When making a connection through a junction box (PN 23550-00), wire point-to-point.

NOTICE

Use a wire nut and pigtail (included) when connecting several wires to the same terminal.

4 Calibrate

4.1 Zero point calibration

Even in the absence of oxygen, the Rosemount 499ATrDO sensor generates a small signal called the zero current. Normally, the zero current is less than 5 nA, which introduces no more than a 0.5 ppb error in measurement. Zero the sensor when it is first placed in service and every time the fill solution is changed.

To zero the sensor:

Procedure

1. Pour a cup of deionized or bottled water.
2. Add a teaspoon of sodium sulfite to the water.
3. Place the sensor in the water.
4. Wait until the sensor current has reached a stable low value (at least two hours).
5. Measure the current.
 - a. If it is less than 5 nA, do not zero the sensor.
 - b. If it is between 5 and 10 nA, allow the sensor to run overnight. Zero the sensor if the reading is still between 5 and 10 nA and is stable.
 - c. If it is greater than 10 nA, call the factory.

4.2 Full scale

The Rosemount 499ATrDO sensor is best calibrated by exposing the sensor to water-saturated air.

1. Pour a small amount of water into a cup.
2. Suspend the sensor, keeping the membrane dry, about 1/4 in. (6 mm) above the surface of the water.
3. Once readings are stable, which should take no longer than 20 minutes, follow the analyzer prompts to complete the calibration.

The analyzer automatically calculates the equilibrium solubility of atmospheric oxygen in water under the prevailing temperature and barometric pressure.

4. After calibration, go to the Diagnostics menu and check the sensitivity.

The sensitivity should be between 3,600 and 6,100 nA/ppm.

For more information, refer to the transmitter manual.

Prolonged exposure to air may affect the linearity of the sensor. If the cumulative exposure to air is less than about five hours per year, sensor linearity should be within specification. If cumulative exposure exceeds five hours per year, restore linear response of the sensor by draining the electrolyte solution and replacing it with fresh.

5 Maintenance

Periodic maintenance and cleaning are required for best performance of the sensor. Generally, the membrane and fill solution should be replaced every four to six months. The optimum maintenance frequency is best determined by experience. Periodically check the zero current and sensitivity. If the zero current is less than about 5 nA, and the current in the air is between 30 and 45 nA with a variability of less than 2%, the sensor does not need maintenance.

⚠ WARNING!

PRESSURIZED SPRAY INJURY

Before removing the sensor, be absolutely certain that the process pressure is reduced to 0 psig and the process temperature is lowered to a safe level!

5.1 Cleaning the membrane

Keep the membrane clean and free from solid corrosion products. Clean the membrane with water sprayed from a wash bottle or gently wipe the sensor with a soft, clean tissue.

5.2 Replacing the electrolyte solution and membrane

⚠ WARNING!

HARMFUL SUBSTANCE

Fill solution may cause irritation. May be harmful if swallowed. Read and follow manual.

Procedure

1. Unscrew the membrane retainer.
2. Remove the membrane assembly and O-ring.
See [Figure 1-1](#).
3. Hold the sensor over a container with the cathode pointing down.
4. Remove the fill plug.
5. Allow the electrolyte solution to drain out.
6. Inspect the cathode.
 - a. If it is tarnished, clean it by gently rubbing in the direction of the existing scratches (do not use a circular motion) with 400-600 grit silicon carbide finishing paper.

7. Remove the old pipe tape from the plug.
8. Wrap the plug with one or two turns of pipe tape.
9. Prepare a new membrane.
 - a. Hold the membrane assembly with the cup formed by the membrane and membrane holder pointing up.
 - b. Place a drop of isopropyl alcohol in the cup.
 - c. Slowly add about 20 drops of electrolyte solution to the cup.

This step is important, because alcohol wets the inside surface of the membrane and ensures that no air bubbles will be trapped when the membrane assembly is placed over the cathode.

- d. Fill the cup with electrolyte solution.
 - e. Leave the membrane assembly filled with electrolyte solution and set it aside.
10. Hold the sensor at about a 45° angle with the cathode end pointing up.
11. Add electrolyte solution through the fill hole until the liquid overflows.
12. Tap the sensor near the threads to release trapped air bubbles.
13. Add more electrolyte solution if necessary.
14. Place the fill plug in the electrolyte port and begin screwing it in.
15. After several threads have engaged, rotate the sensor so that the cathode is pointing up and continue tightening the fill plug.

Do not overtighten.

16. Place a new O-ring in the groove around the cathode post.
17. Cover the holes at the base of the cathode stem with several drops of electrolyte solution.
18. Insert a small blunt probe, like a toothpick with the end cut off, through the pressure equalizing port.

See [Figure 1-1](#).

⚠ CAUTION!

EQUIPMENT DAMAGE

Do not use a sharp probe. It will puncture the bladder and destroy the sensor.

19. Gently press the probe against the bladder several times to force liquid through the holes at the base of the cathode stem. Keep pressing the bladder until no air bubbles can be seen leaving the holes. Be sure the holes remain covered with electrolyte solution.
20. Place a drop of electrolyte solution on the cathode; then place the membrane assembly over the cathode.
21. Screw the membrane retainer in place.

The sensor may require several hours operating at the polarizing voltage to equilibrate after the electrolyte solution has been replenished.

5.3 Storage

Store the sensor with the membrane immersed in a fresh solution of saturated sodium sulfite. You can use the PVC cap shipped with the sensor. Leave the power to the transmitter turned on.

6 Accessories

Part number	Description
23747-06	Interconnecting cable, VP 6, 2.5 ft (0.8 m)
23747-04	Interconnecting cable, VP 6, 4 ft (1.2 m)
23747-02	Interconnecting cable, VP 6, 10 ft (3.0 m)
23747-07	Interconnecting cable, VP 6, 15 ft (4.6 m)
23747-08	Interconnecting cable, VP 6, 20 ft (6.1 m)
23747-09	Interconnecting cable, VP 6, 25 ft (7.6 m)
23747-10	Interconnecting cable, VP 6, 30 ft (9.1 m)
23747-03	Interconnecting cable, VP 6, 50 ft (15.2 m)
23747-11	Interconnecting cable, VP 6, 100 ft (30.5 m)
24091-00	Low flow cell with 1/4 in. OD tubing compression fittings
9390004	Rotameter: 0.5 - 5.0 gph
22550-00	Junction box, 12 terminals
9200266	Extension cable, standard, unprepped
9200275	Extension cable for optimum EMI/RFI cable, unprepped
23747-00	Extension cable for optimum EMI/RFI cable, prepped
23501-04	Trace dissolved oxygen membrane kit: includes 1 membrane assembly and 1 O-ring
25302-04	Trace dissolved oxygen membrane kit: includes 3 membrane assemblies and 3 O-rings
9210264	Dissolved oxygen sensor fill solution, 4 oz (125 mL)
33521-02	Membrane retainer
33523-03	Electrolyte fill plug
9390094	O-ring, Viton 2-014

www.Emerson.com/RosemountLiquidAnalysis

Emerson Automation Solutions

8200 Market Blvd

Chanhassen, MN 55317

Toll Free +1 800 999 9307

F +1 952 949 7001

liquid.csc@emerson.com**www.Emerson.com/RosemountLiquidAnalysis****EUROPE**

Emerson Automation Solutions

Neuhofstrasse 19a P.O. Box 1046

CH-6340 Baar

Switzerland

T + 41 (0) 41 768 6111

F + 41 (0) 41 768 6300

liquid.csc@emerson.com**www.Emerson.com/RosemountLiquidAnalysis****MIDDLE EAST AND AFRICA**

Emerson Automation Solutions

Emerson FZE

Jebel Ali Free Zone

Dubai, United Arab Emirates, P.O. Box 17033

T +971 4 811 8100

F +971 4 886 5465

liquid.csc@emerson.com**www.Emerson.com/RosemountLiquidAnalysis****ASIA-PACIFIC**

Emerson Automation Solutions

1 Pandan Crescent

Singapore 128461

Singapore

T +65 777 8211

F +65 777 0947

liquid.csc@emerson.com**www.Emerson.com/RosemountLiquidAnalysis**

©2017 Emerson Automation Solutions. All rights reserved.

The Emerson logo is a trademark and service mark of Emerson Electric Co. Rosemount is a mark of one of the Emerson family of companies. All other marks are the property of their respective owners. The contents of this publication are presented for information purposes only, and while effort has been made to ensure their accuracy, they are not to be construed as warranties or guarantees, expressed or implied, regarding the products or services described herein or their use or applicability. All sales are governed by our terms and conditions, which are available on request. We reserve the right to modify or improve the designs or specifications of our products at any time without notice.