

Rosemount™ 499AOZ

Dissolved Ozone Sensor



Safety information

CAUTION!

SENSOR/PROCESS APPLICATION COMPATIBILITY

The wetted sensor material may not be compatible with process composition and operating conditions. Application compatibility is entirely your responsibility.

CAUTION!

EQUIPMENT DAMAGE

Do not exceed pressure and temperature specifications.

Pressure: 65 psig (549 kPa abs) max. Temperature: 32 to 122 °F (0 to 50 °C)

Contents

Chapter 1	Plan	1
	1.1 Unpacking and inspection	1
	1.2 Product description	1
	1.3 Specifications	1
Chapter 2	Install	5
Chapter 3	Wire	9
Chapter 4	Calibrate	17
	4.1 Zero point calibration	17
	4.2 Full scale calibration	17
Chapter 5	Maintenance	19
	5.1 Cleaning the membrane	19
	5.2 Replacing the electrolyte solution and membrane	19
Chapter 6	Accessories	21

1 Plan

1.1 Unpacking and inspection

1. Inspect the shipping container. If it is damaged, contact the shipper immediately for instructions.
2. Save the box.
3. If there is no apparent damage, unpack the container. Be sure all items shown on the packing list are present. If items are missing, notify Rosemount immediately.

1.2 Product description

Figure 1-1: Rosemount 499AOZ Sensor Parts

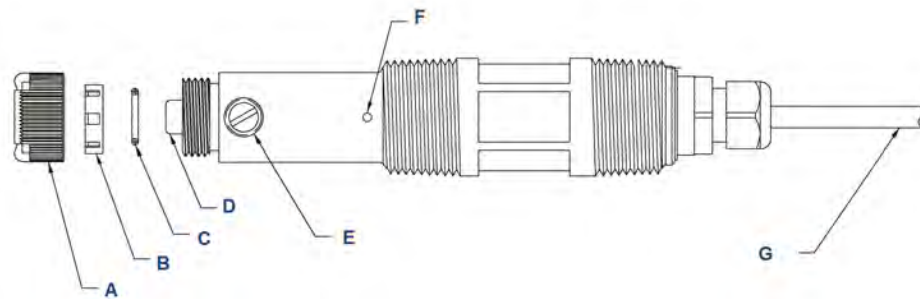

- A. Membrane retainer
- B. Membrane assembly
- C. O-ring
- D. Cathode
- E. Electrolyte fill plug (wrap with pipe tape)
- F. Pressure equalizing port
- G. Sensor cable (integral cable shown)

1.3 Specifications

Table 1-1: Sensor specifications

Physical characteristics	Specifications
Range	0 to 3 ppm (mg/L) as O ₃
Pressure	0 to 65 psig (101 to 549 kPa abs)
Temperature (operating)	0 to 50 °C (32 to 122 °F)

Table 1-1: Sensor specifications (continued)

Physical characteristics	Specifications	
Process connection	1 in. MNPT	
Wetted parts	Polysulfone, Viton [®] , Teflon [®] , ⁽¹⁾ and silicone	
Cathode	Gold (not normally wetted)	
Accuracy	Accuracy depends on the accuracy of the chemical test used to calibrate the sensor.	
Linearity	±5% of reading or ±3 ppb (whichever is greater) at 77 °F (25 °C)	
Repeatability	±2% of reading at constant temperature	
Response time	30< 20 sec to 90% of final reading at 25 °C (77 °F)	
Membrane permeability connection	Defined between 41 and 95 °F (0 and 50 °C)	
Process connection	1 in. MNPT	
Electrolyte volume	25 mL (approx.)	
Electrolyte life	3 months (approx.); for best results, replace electrolyte monthly.	
Cable length (standard integral cable)	25 ft (7.6 m)	
Cable length (maximum)	300 ft (91 m)	
Sample flow		
	Flow through	1 to 5 gpm (3.8 to 19 L/min)
	Open channel	1 ft/sec (0.3 m/sec)
	Low flow cell	2 to 5 gph (7.6 to 19 L/hr)
Process connections	Sensor must be used in flow cell PN 24091-01	
Weight/shipping weight ⁽²⁾	1 lb/3 lb (0.5kg /1.5 kg)	

(1) Viton and Teflon are registered trademarks of E.I. duPont de Nemours & Co.

(2) Weights and shipping weights are rounded up to the nearest whole pound or 0.5 kg.

Table 1-2: Other specifications

Type	PN	Wetted materials	Process connection	Maximum temperature	Maximum pressure
2 in. tee	915240-03	PVC and Buna N; body is schedule 80 PVC	3/4 in. NFPT	120 °F (49 °C)	60 psig (515 kPa abs)
	915240-04		1 in. NFPT		
	915240-05		1-1/2 in. NFPT		
Low flow cell ⁽¹⁾	24091-00	Polycarbonate/polyester, 316 stainless steel, and silicone	Compression fitting for 1/4 in. O.D. tubing or 1/4 in. FNPT	158 °F (70 °C)	90 psig (722 kPa abs)

Table 1-2: Other specifications (continued)

Type	PN	Wetted materials	Process connection	Maximum temperature	Maximum pressure
Valved rotameter	9390004 for use with low flow cell	Acrylic, 316 stainless steel, and Viton	1/4 in. NFPT (316 stainless steel)	150 °F (65 °C)	100 psig (858 kPa abs)

(1) Temperature and pressure specifications for the low flow cell exceed the temperature and pressure specifications for the sensor.

2 Install

Install the sensor in a flowing sample. Keep the sample flow as constant as possible at a value within the following limits:

Sample flow unit	Flow limits
Flow through	1 to 5 gpm (3.8 to 19 L/min)
Open channel	1 ft/sec (0.3 m/sec)
Low flow cell	2 to 5 gph (7.6 to 19 L/hr)

Figure 2-1: Sensor Orientation

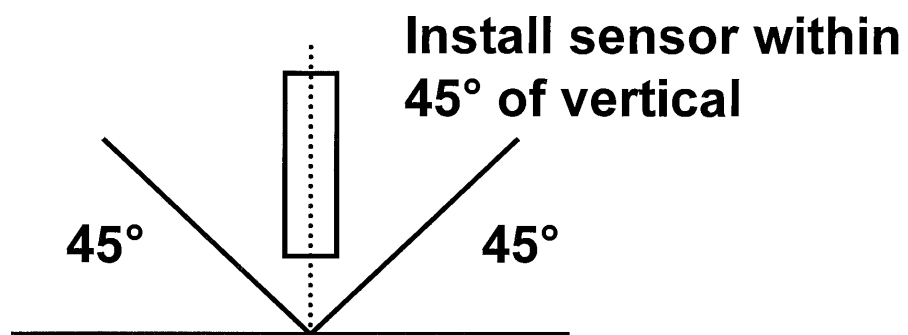

Figure 2-2: Flow through 1-1/2 in. Tee

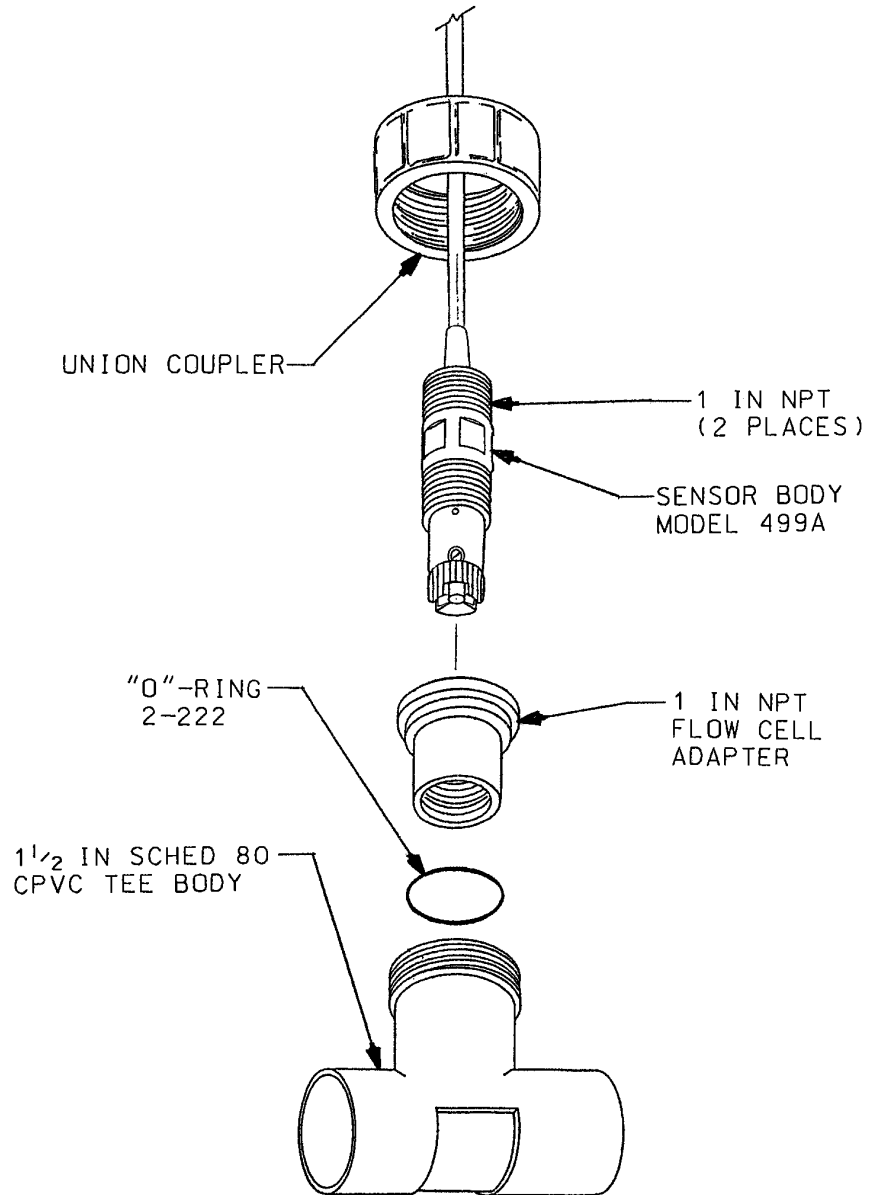

Figure 2-3: Flow through 2 in. Tee

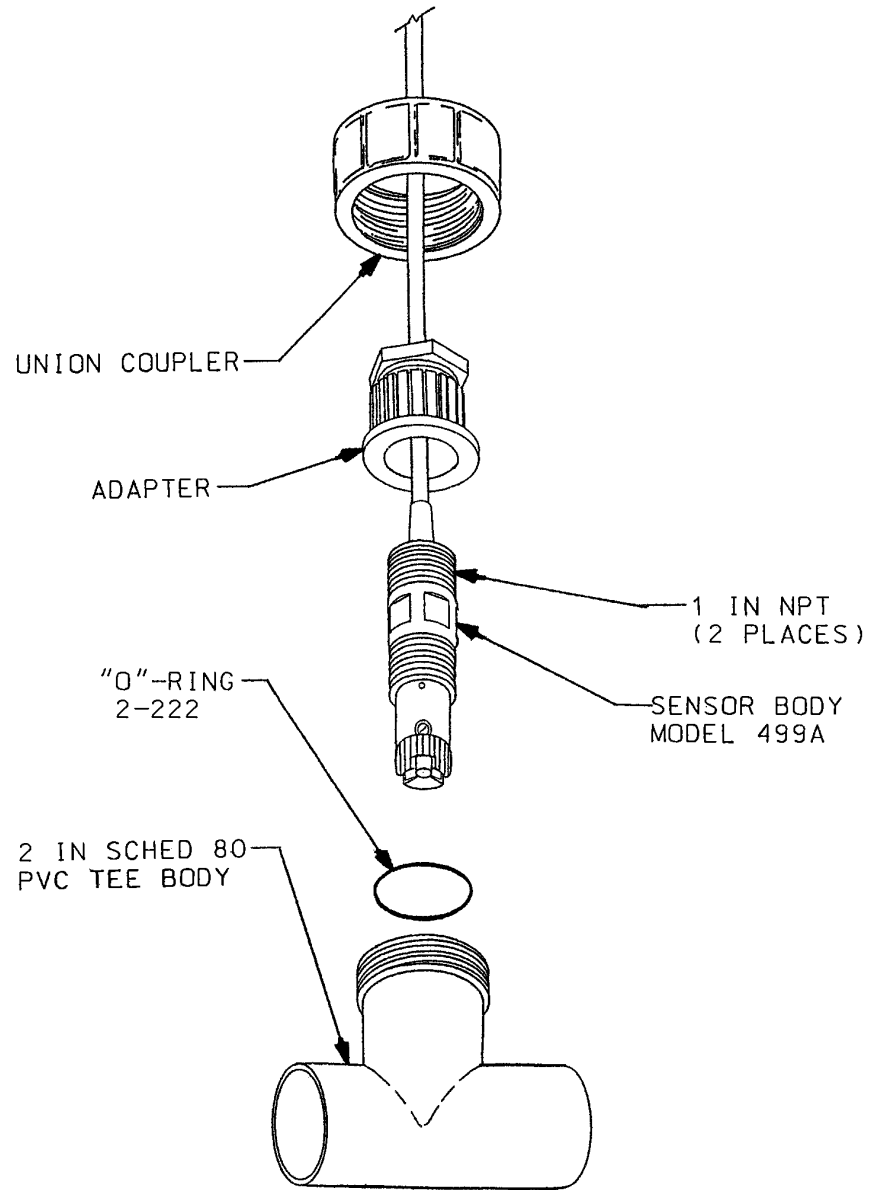
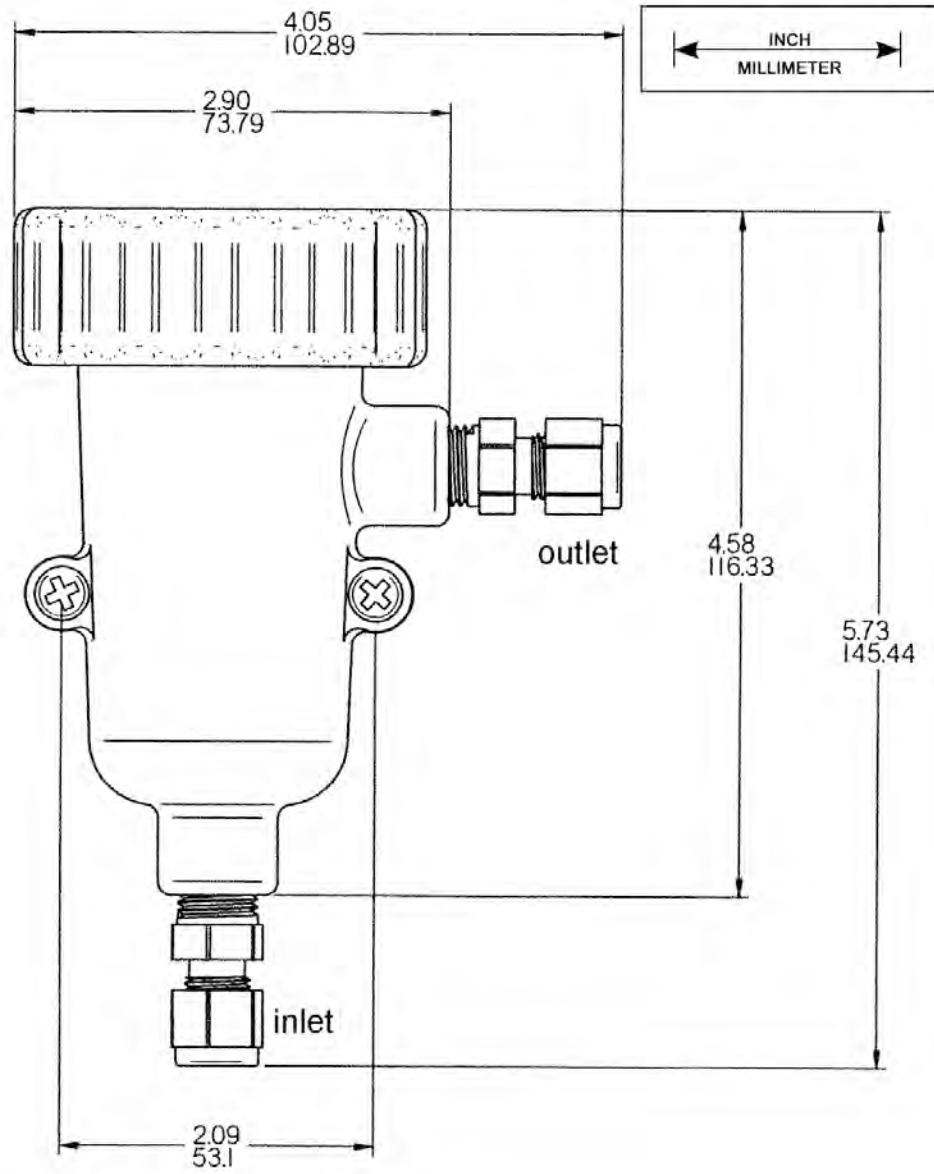

Figure 2-4: Low Flow Cell (PN 24091-00)



3 Wire

NOTICE

For additional wiring information on this product, including sensor combinations not shown here, please refer to the [Liquid Transmitter Wiring Diagrams](#).

Figure 3-1: Rosemount 499AOZ-54 Sensor Wiring to Rosemount 1056 and 56 Transmitters

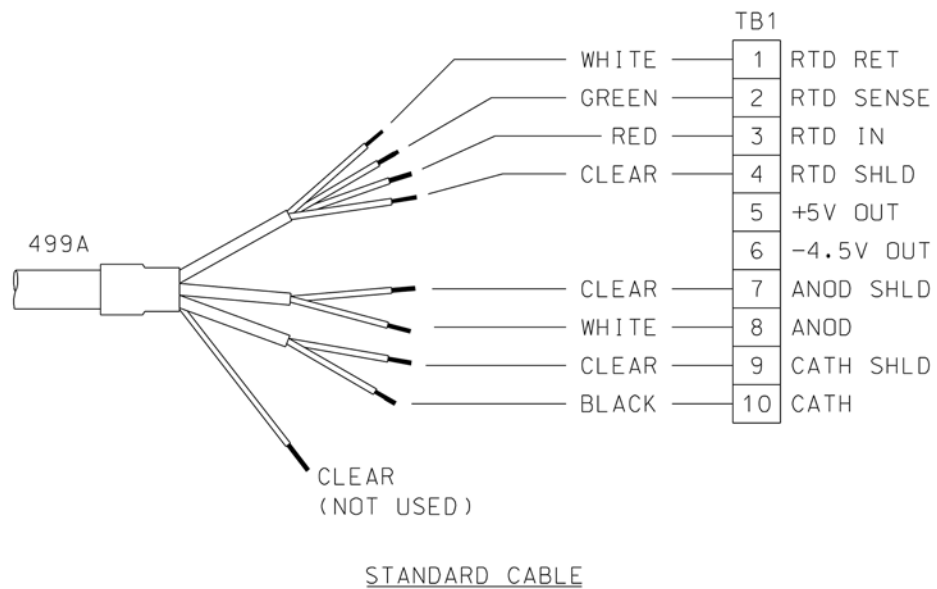
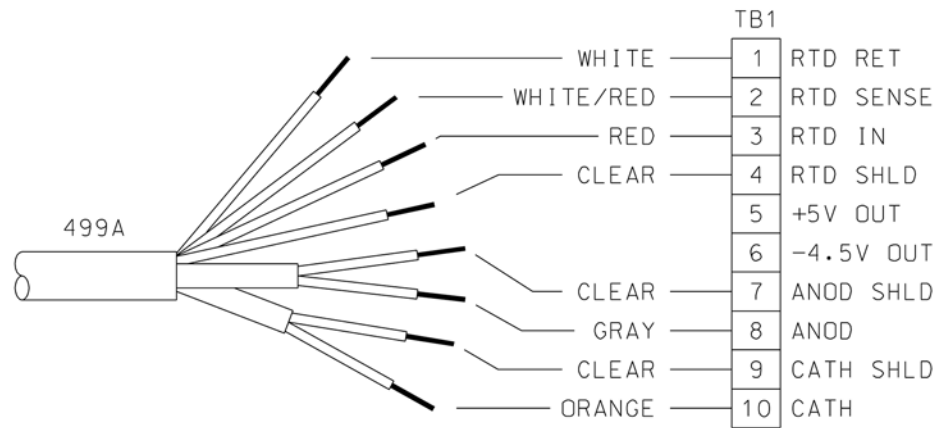

Figure 3-2: Rosemount 499AOZ-54-60 and Rosemount 499AOZ-54-VP Sensor Wiring to Rosemount 1056 and 56 Transmitters



VARIOPOL AND EMI/RFI CABLE

Figure 3-3: Rosemount 499AOZ-54 Sensor Wiring to Rosemount 5081 transmitter

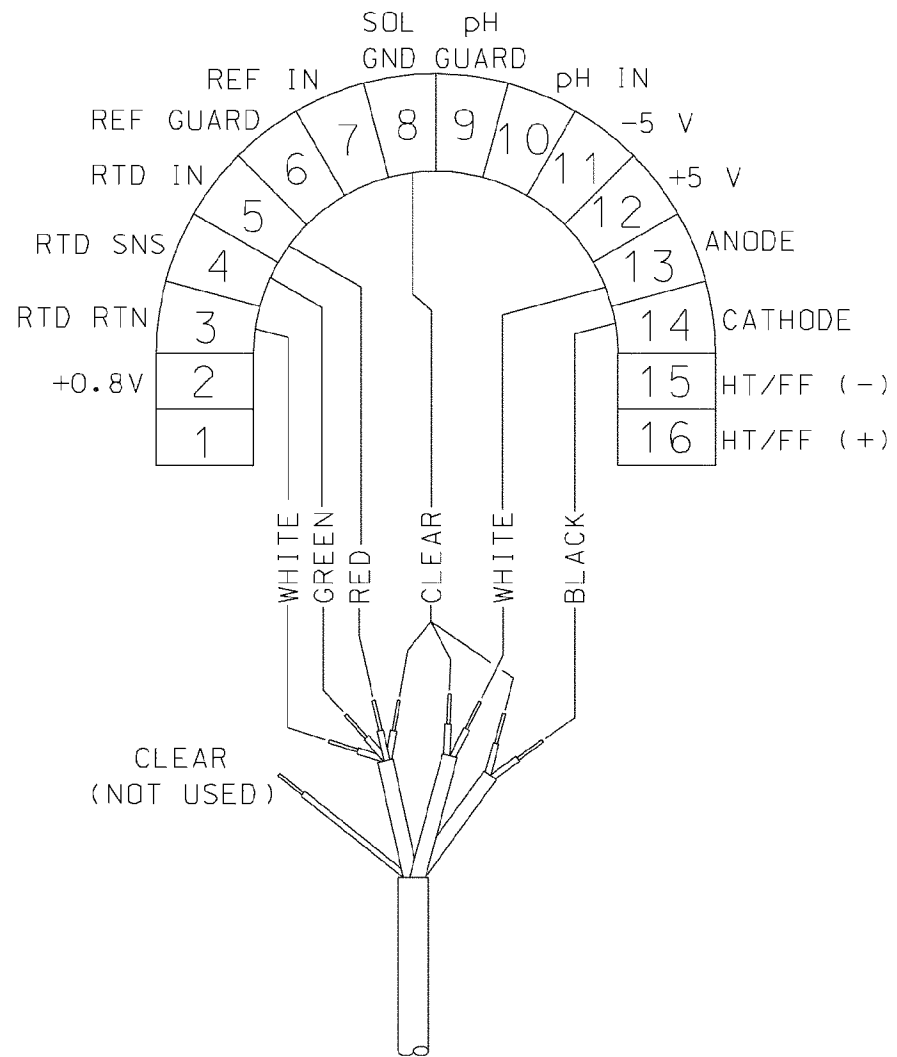

Figure 3-4: Rosemount 499AOZ-54-60 and 499AOZ-54-VP Sensor Wiring to Rosemount 5081 Transmitter

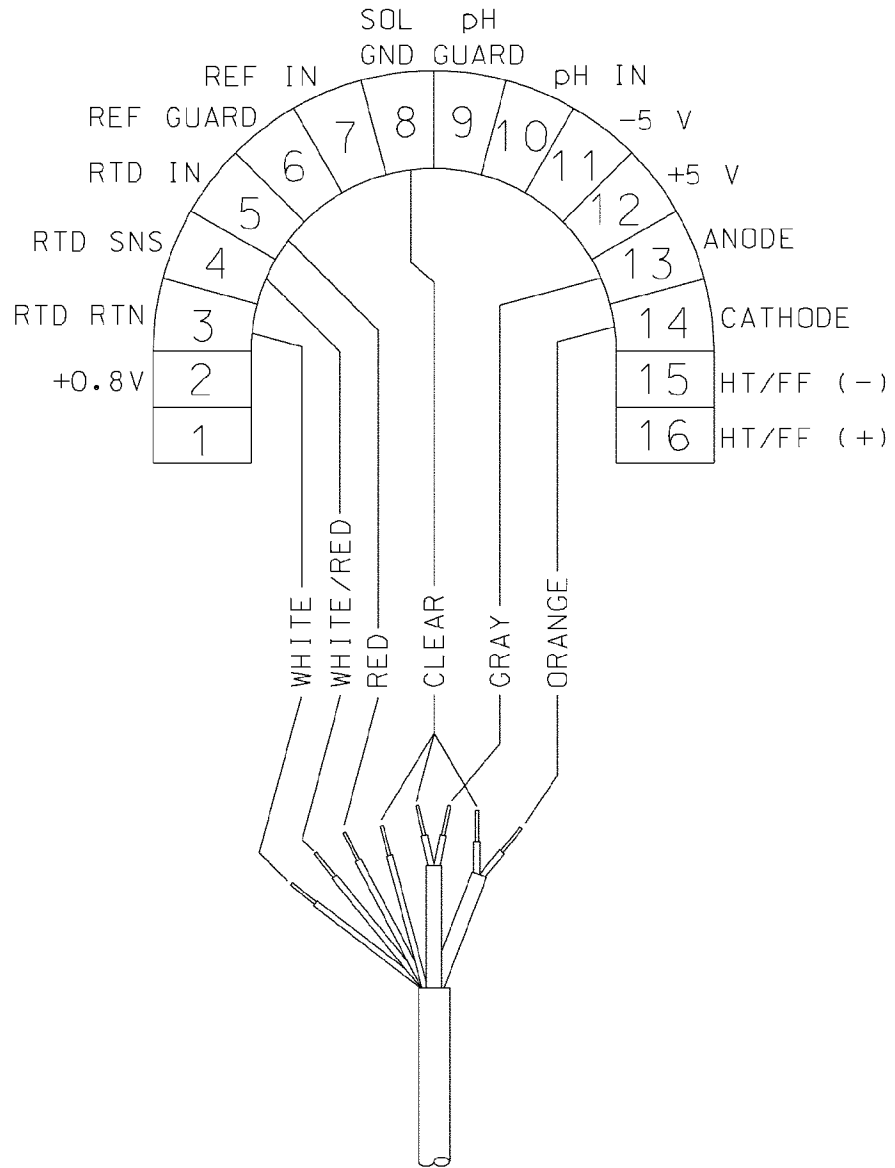
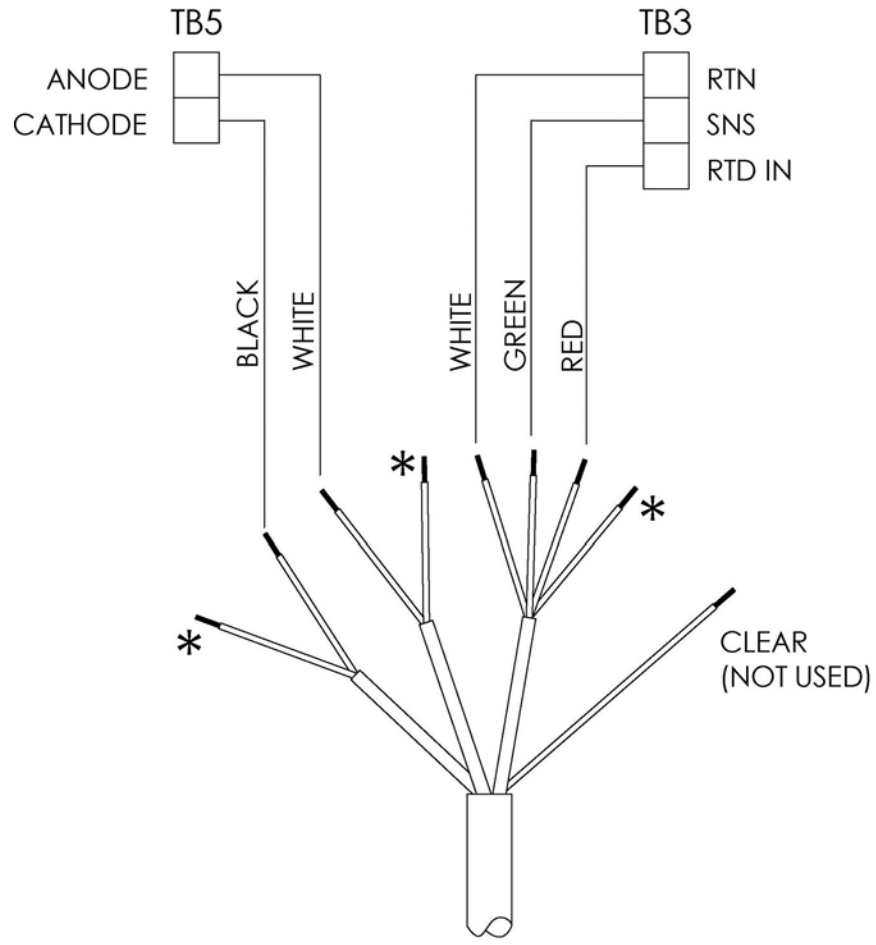
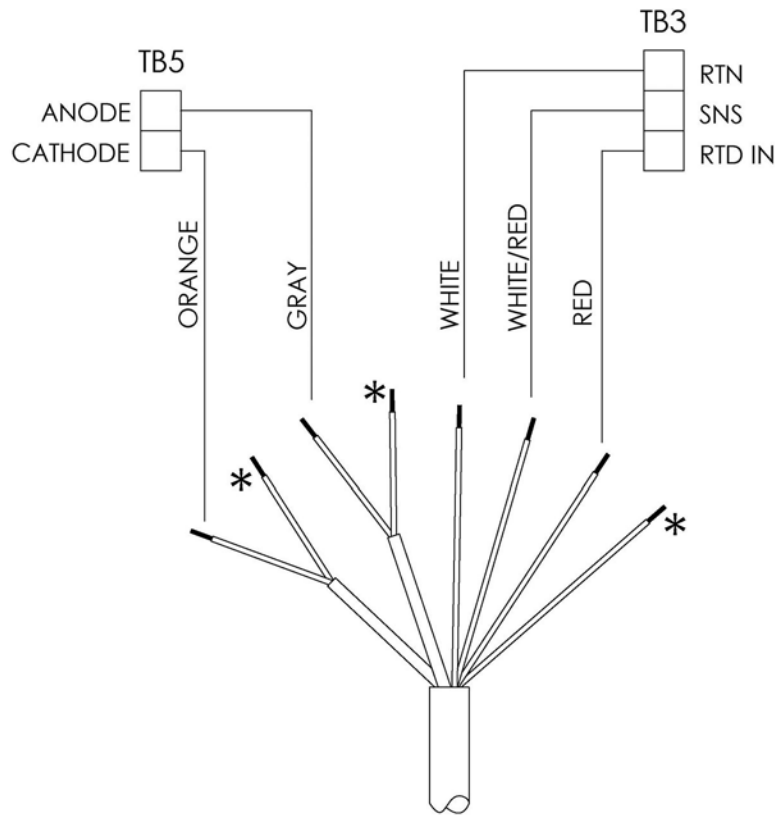

Figure 3-5: Rosemount 499AOZ-54 Sensor Wiring to Rosemount 1066 Transmitter

* CONNECT CLEAR SHIELD WIRES TO SOL GND TERMINAL ON TB 2. USE WIRE NUT AND PIGTAIL IF NECESSARY.

Figure 3-6: Rosemount 499AOZ-54-60 and 499AOZ-54-VP Sensor Wiring to Rosemount 1066 Transmitter



* CONNECT CLEAR SHIELD WIRES TO SOL GND TERMINAL ON TB 2. USE WIRE NUT AND PIGTAIL IF NECESSARY.

Figure 3-7: Rosemount 499AOZ-54-VP Sensor Pin-out Diagram (Top View of Connector End of Sensor)

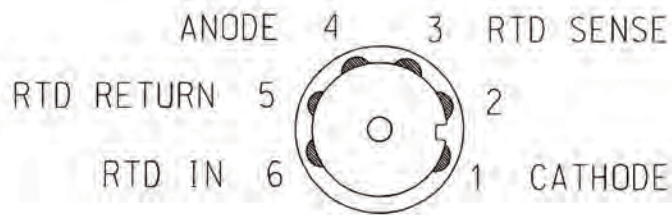

When making a connection through a junction box (PN 23550-00), wire point-to-point.

NOTICE

Use a wire nut and pigtail (included) when connecting several wires to the same terminal.

4 Calibrate

4.1 Zero point calibration

Even in the absence of ozone, the Rosemount 499AOZ sensor generates a small signal called the zero current. Failing to correct for the zero current can introduce a bias, particularly if the ozone concentration is small (<0.4 ppm). Zero the sensor when it is first placed in service and every time the fill solution is changed.

To zero the sensor:

Procedure

1. Pour a cup of deionized or bottled water.
2. Place the sensor in the water.
3. Wait until the sensor current has reached a stable low value (at least two hours).
4. Follow the transmitter prompts for zeroing the sensor.

Note

Refer to the manual for the transmitter you are using (56, 1056, 5081, or 1066).

The zero current should be between -10 and +10 nA.

4.2 Full scale calibration

Because stable dilute ozone standards are not available, the sensor must be calibrated against the results of a laboratory test run on a grab sample of the process liquid.

1. Place the sensor in the flow cell.
2. Start the sample and reagent flow.
3. Adjust the sample flow to the correct range.
4. Adjust the concentration so that it is near the upper end of the operating range.
5. Wait for the readings to stabilize.
6. Follow the transmitter prompts to complete the calibration.

Note

Refer to the manual for the transmitter you are using (56, 1056, 5081, or 1066).

7. After calibration, go to the Diagnostics menu and check the sensitivity.

The sensitivity should be between 250 and 450 nA/ppm. For more information, refer to the transmitter manual.

5 Maintenance

Periodic maintenance and cleaning are required for best performance of the sensor. Generally, the membrane and fill solution should be replaced every four to six months. Sensors installed in harsh or dirty environments require more frequent maintenance. The optimum maintenance frequency is best determined by experience.

⚠ WARNING!

PRESSURIZED SPRAY INJURY

Before removing the sensor, be absolutely certain that the process pressure is reduced to 0 psig and the process temperature is lowered to a safe level!

5.1 Cleaning the membrane

Keep the membrane and sensor tip clean and free from dirt. Clean the membrane with water sprayed from a wash bottle. Use a soft tissue to gently wipe the membrane.

5.2 Replacing the electrolyte solution and membrane

⚠ WARNING!

HARMFUL SUBSTANCE

Fill solution may cause irritation. May be harmful if swallowed. Read and follow manual.

Procedure

1. Unscrew the membrane retainer.
2. Remove the membrane assembly and O-ring.
See [Figure 1-1](#).
3. Hold the sensor over a container with the cathode pointing down.
4. Remove the fill plug.
5. Allow the electrolyte solution to drain out.
6. Inspect the cathode.
 - a. If it is tarnished, clean it by gently rubbing in the direction of the existing scratches (do not use a circular motion) with 400-600 grit silicon carbide finishing paper.
 - b. Rinse thoroughly with water.
7. Remove the old pipe tape from the plug.

8. Wrap the plug with one or two turns of pipe tape.
9. Prepare a new membrane.
 - a. Hold the membrane assembly with the cup formed by the membrane and membrane holder pointing up.
 - b. Fill the cup with electrolyte solution.
 - c. Leave the membrane assembly filled with electrolyte solution and set it aside.
10. Hold the sensor at about a 45° angle with the cathode end pointing up.
11. Add electrolyte solution through the fill hole until the liquid overflows.
12. Tap the sensor near the threads to release trapped air bubbles.
13. Add more electrolyte solution if necessary.
14. Place the fill plug in the electrolyte port and begin screwing it in.
15. After several threads have engaged, rotate the sensor so that the cathode is pointing up and continue tightening the fill plug.

Do not overtighten.
16. Place a new O-ring in the groove around the cathode post.
17. Cover the holes at the base of the cathode stem with several drops of electrolyte solution.
18. Insert a small blunt probe, like a toothpick with the end cut off, through the pressure equalizing port.

See [Figure 1-1](#).

⚠ CAUTION!

EQUIPMENT DAMAGE

Do not use a sharp probe. It will puncture the bladder and destroy the sensor.

19. Gently press the probe against the bladder several times to force liquid through the holes at the base of the cathode stem. Keep pressing the bladder until no air bubbles can be seen leaving the holes. Be sure the holes remain covered with electrolyte solution.
20. Place a drop of electrolyte solution on the cathode; then place the membrane assembly over the cathode.
21. Screw the membrane retainer in place.

The sensor may require several hours operating at the polarizing voltage to equilibrate after the electrolyte solution has been replenished.

6 Accessories

Part number	Description
23747-06	Interconnecting cable, VP 6, 2.5 ft (0.8 m)
23747-04	Interconnecting cable, VP 6, 4 ft (1.2 m)
23747-02	Interconnecting cable, VP 6, 10 ft (3.0 m)
23747-07	Interconnecting cable, VP 6, 15 ft (4.6 m)
23747-08	Interconnecting cable, VP 6, 20 ft (6.1 m)
23747-09	Interconnecting cable, VP 6, 25 ft (7.6 m)
23747-10	Interconnecting cable, VP 6, 30 ft (9.1 m)
23747-03	Interconnecting cable, VP 6, 50 ft (15.2 m)
23747-11	Interconnecting cable, VP 6, 100 ft (30.5 m)
23567-00	1-1/2 in. flow through tee with 1-1/2 in. socket connections
915240-03	2 in. flow through tee with 3/4 in. FNPT connections
915240-04	2 in. flow through tee with 1 in. FNPT connections
915240-05	2 in. flow through tee with 1-1/2 in. FNPT connections
24091-00	Low flow cell with 1/4 in. OD tubing compression fittings
9390004	Rotameter: 0.5 - 5.0 gph
22550-00	Junction box, 12 terminals
9200266	Extension cable for option -54, unterminated (specify length)
9200275	Extension cable for optimum EMI/RFI cable, unterminated (specify length)
23747-00	Extension cable for optimum EMI/RFI cable, terminated (specify length)
2001492	Stainless steel tag
23501-11	Dissolved ozone membrane assembly; includes 1 membrane assembly and 1 O-ring
23502-11	Dissolved ozone membrane assembly; includes 3 membrane assemblies and 3 O-rings
9210299	#3 Dissolved ozone sensor fill solution, 4 oz (125 ml)
33521-02	Membrane retainer
33523-03	Fill plug

www.Emerson.com/RosemountLiquidAnalysis

Emerson Automation Solutions

8200 Market Blvd

Chanhassen, MN 55317

Toll Free +1 800 999 9307

F +1 952 949 7001

liquid.csc@emerson.com**www.Emerson.com/RosemountLiquidAnalysis****EUROPE**

Emerson Automation Solutions

Neuhofstrasse 19a P.O. Box 1046

CH-6340 Baar

Switzerland

T + 41 (0) 41 768 6111

F + 41 (0) 41 768 6300

liquid.csc@emerson.com**www.Emerson.com/RosemountLiquidAnalysis****MIDDLE EAST AND AFRICA**

Emerson Automation Solutions

Emerson FZE

Jebel Ali Free Zone

Dubai, United Arab Emirates, P.O. Box 17033

T +971 4 811 8100

F +971 4 886 5465

liquid.csc@emerson.com**www.Emerson.com/RosemountLiquidAnalysis****ASIA-PACIFIC**

Emerson Automation Solutions

1 Pandan Crescent

Singapore 128461

Singapore

T +65 777 8211

F +65 777 0947

liquid.csc@emerson.com**www.Emerson.com/RosemountLiquidAnalysis**

©2017 Emerson Automation Solutions. All rights reserved.

The Emerson logo is a trademark and service mark of Emerson Electric Co. Rosemount is a mark of one of the Emerson family of companies. All other marks are the property of their respective owners. The contents of this publication are presented for information purposes only, and, while effort has been made to ensure their accuracy, they are not to be construed as warranties or guarantees, expressed or implied, regarding the products or services described herein or their use or applicability. All sales are governed by our terms and conditions, which are available on request. We reserve the right to modify or improve the designs or specifications of our products at any time without notice.