



PanaFlow™ MV84

In-line multivariable flow meters for mass, temperature and pressure

PanaFlow MV84 In-line Multivariable Mass Vortex flow meter is the next generation vortex meter. PanaFlow MV84's multivariable design consists of a vortex shedding velocity sensor, an RTD temperature sensor and a solid state pressure transducer that measures the mass flow rate of steam, gases and liquids. Other meter types use external process measurements to calculate mass flow. The temperature and pressure devices are typically not installed in the same location as the flowmeter. Process conditions can vary greatly between the two locations, causing inaccurate mass flow readings. PanaFlow MV84 measures velocity, temperature and pressure at the same location, which provides more accurate process measurement.

Portfolio of flow meter solutions

Panametrics is committed to providing customers with the best technologies for their flow measurement needs. PanaFlow MV84 is the newest addition to the PanaFlow family of flow meters, providing effective solutions for smaller pipe sizes for a variety of applications. Panametrics offers the PanaFlow MV84 in a number of configurations to best suit your application measurement needs.

Field service solutions

Panametrics has a global field service team ready to assist in the start-up and commissioning of the PanaFlow MV84 flow meters. This service includes validating the proper installation and programming of the meter, and can include customized training for theory, operation and maintenance. Regularly scheduled preventative maintenance visits will provide peace of mind, ensuring that the meters work to specification and your expectation for years.

Mass flow measurement—true multivariable

The MV84 offers flow computer functionality in a compact field device. The VTP option incorporates temperature and pressure sensors to provide an instantaneous reading of compensated mass flow rate of gases, liquids and steam. In addition to outputs for totalized mass and alarm settings, the field configurable electronics deliver up to three analog 4-20 mA outputs of five process measurements, including volumetric flow rate, mass flow rate, pressure, temperature and density. Alternate configurations for mass flow include a temperature only compensation (VT), best used when in saturated steam applications, and an integrated RTD with an external pressure transmitter (VT-EP) when a full function pressure transmitter is desired.

Energy measurement in liquids and steam

The VT-EM energy monitoring option enables real time-of-flight diffraction calculation of energy consumption for a facility or process. The meter can be programmed to measure steam, hot water or chilled water. This option uses the MV84 flow meter to monitor one side of the process, either sent or return, and uses the input from a second separate temperature sensor on the opposite leg of the process to calculate the change in energy. Selectable energy units include BTU, joules, calories, Watt-hours, Megawatt-hours and Horsepower-hours. The local or remote electronics indicate two temperatures, delta T, mass total and energy total. For energy measurement in steam, the VTP-EM option adds a pressure transmitter to offer better accuracy.

Volumetric flow for most gases and liquids

The base model MV84 delivers a direct reading of volumetric flow rate—generally the most cost-effective solution for liquid flow monitoring—in applications ranging from general water flows to hydrocarbon fuel flow measurement.

Key benefits

- Multivariable vortex flow meter with built-in flow computer for measuring volumetric flow, temperature, pressure, density, energy, and mass flow using a single meter
- Measures most gases, liquids and steam without the need to recalibrate
- Advanced design and digital signal processing for vibration isolation
- Cost effective, accurate and reliable meter for volumetric and mass flow measurement
- Energy management through accurate measurement of both temperature and mass flow simultaneously
- Remote monitoring and integration to DCS using HART®, Modbus®, and BACnet® communication protocols
- Significant cost savings through reduced installation costs, wiring runs and services support using MV meter with no moving parts
- Reducing meter option for increasing the lower measurement range

Applications

- Ideal for high temperature and high velocity steam
- Power Generation—fuel and steam applications
- Industrial—HVAC, district energy management
- Commercial—building, campus and facility energy management
- Oil & Gas—allocation of natural gas
- Petrochemical—mass balancing, reaction processes heating

Model	Configuration	Volumetric flow	Mass flow	Integrated RTD	Integrated pressure	External temperature	External pressure	Typical application	Pipe size*
MV84-V	Volumetric flow for liquid and gas	X						Liquid volumetric flow	1/2" to 12" (15 to 300 mm)
MV84-VT	Mass flow with temperature and assumed saturated steam	X	X	X				Saturated steam and liquid mass flow	1/2" to 12" (15 to 300 mm)
MV84-VTP	Mass flow with integrated temperature and pressure in one device	X	X	X	X			Steam and gases mass flow	1/2" to 12" (15 to 300 mm)
MV84-VT-EP	Mass flow with integrated temperature and analog input for an external pressure transmitter	X	X	X			X	Steam and gases mass flow (special material, high pressure)	1/2" to 12" (15 to 300 mm)
MV84-VT-EM	Energy using integrated temperature and one input for an RTD transmitter	X		X		X		Saturated steam and liquid energy	1/2" to 12" (15 to 300 mm)
MV84-VTP-EM	Energy for steam with integrated pressure and temperature and one input for an RTD transmitter	X	X	X	X	X		Steam energy	1/2" to 12" (15 to 300 mm)

Technical Specifications

Performance

Accuracy Mass flow rate accuracy for gas and steam based on 50–100% of pressure range.

PanaFlow MV82 flow meter accuracy		
Process variable	Liquids	Gas and steam
Volumetric flow rate	± 0.7% of rate	± 1% of rate
Mass flow rate	± 1% of rate	± 1.5% of rate
Temperature	± 2°F (± 1°C)	± 2°F (± 1°C)
Pressure	± 0.3% of full scale	± 0.3% of full scale
Density	± 0.3% of reading	± 0.5% of reading

Repeatability

- Mass flow rate: ±0.2% of rate
- Volumetric flow rate: ±0.1% of rate
- Temperature: ±0.2°F (± 0.1°C)
- Pressure: ±0.05% of full scale
- Density: ±0.1% of reading

Stability over 12 months

- Mass flow rate: ±0.2% of rate
- Volumetric flow rate: negligible
- Temperature: ±0.9°F (± 0.5°C)
- Pressure: ±0.1% of full scale
- Density: ±0.1% of reading

Response time Adjustable from 1 to 100 seconds

Operating

Process and ambient temperature

- Process standard temperature (code st): -40 to 500°F (-40 to 260°C)
- Process high temperature (code ht): up to 750°F (400°C)
- Ambient operating: -40 to 140°F (-40 to 60°C)
- Ambient storage: -40 to 185°F (-40 to 85°C)

Pressure transducer ratings			
Full scale operating pressure		Max. over-range pressure	
psia	bara	psia	bara
30	2	60	4
100	7	200	14
300	20	600	40
500	35	1000	70
1500	100	2500	175

Power requirements

- DC2 option: 12–36 VDC loop powered, 25mA, 1W max, loop powered (single output)
- DC4 option: 12–36 VDC, 300 mA max, 9W max, (multiple outputs)
- DC4POE option: 12–28 VDC or power over Ethernet, 5W max, (multiple outputs)
- AC option: 100–240 VAC, 50/60 Hz, 5 Watt (multiple outputs)

Display Alphanumeric 2 line x 16 character LCD Digital Display: six pushbuttons for full field configuration. Pushbuttons can be operated with magnetic wand without removal of enclosure covers. Display can be mounted in 90° intervals for better viewing.

Output signals

- Analog: 4–20 mA, loop powered for volumetric meters
- Alarm: Solid state relay, 40 VDC
- Totalizer pulse: 50 millisecond, 40 VDC
- DC2 option: One analog, one totalizer pulse, HART
- DC4, DC4POE, and AC option: Up to three analog signals, three alarms, one totalizer pulse, HART, Modbus, BACnet

Physical

Wetted materials 316L stainless steel standard, plus:

- PTFE based thread sealant on models with pressure transducer
- PTFE packing on standard temperature models with packing gland
- Graphite-based packing on high temperature models with packing gland
- Carbon steel and Hastelloy C meter bodies optional

Certifications

- FM/FMC Class I, Division 1, Groups B, C and D, Class II, III, Division 1, Groups E, F & G
- Type 4x and IP66, T6, Ta = -40°C - +60°C
- ATEX II 2 G Ex d IIB + H2 T6, II 2 D Ex tD A21 IP66 T85°C, Ta = -40°C - +60°C
- IECEx Ex d IIB + H2 T6, Ex tD A21 IP66 T85°C, Ta = -40°C - +60°C

Sizing considerations

Condition	Pipe diameters, D	
	Upstream	Downstream
One 90° elbow before meter	10D	5D
Two 90° elbows before meter	15D	5D
Two 90° elbows before meter, out of plane	25D	5D
Reduction before meter	10D	5D
Expansion before meter	20D	5D
Partially open valve	25D	5D

Velocity and flow rate ranges

Velocity range

- Maximum for liquids: 30 ft/s (9 m/s)
- Minimum for liquids: 1 ft/s (0.3 m/sec)
- Maximum for gases or steam: 300 ft/s (90 m/s)
- Minimum for gases or steam: see equations below

$$ft/s = \sqrt{\frac{5}{\text{density (lb/ft}^3)}} \quad m/s = \sqrt{\frac{6.1}{\text{density (kg/m}^3)}}$$

Turndown ratio

The turndown ratio is application-dependent, and it can exceed 100:1. Consult the PanaFlow MV Sizing Program for exact values.

Flow rate ranges for water

Refer to the table below for minimum and maximum flow rate ranges, or use the PanaFlow MV Sizing Program to calculate your flow rate range.

Minimum and maximum flow rates for water									
Rate	Nominal pipe size (in.)								
	0.5	0.75	1	1.5	2	3	4	6	8
GPM min.	0.9	1.4	2.2	5.5	9.2	21	36	81	142
GPM max.	22	40	67	166	276	618	1076	2437	4270
Rate	Nominal pipe size (mm)								
	15	20	25	40	50	80	100	150	200
m ³ /hr min.	0.2	0.3	0.5	1.3	2.3	4.7	8.1	18	32
m ³ /hr max.	5	9	15	38	63	140	244	554	970

Upon the recommendation of a Panametrics application engineer, a concentric reducer inline flow body may be requested.

Flow rate ranges for saturated steam

Refer to the tables below for minimum and maximum flow rate ranges, or use the PanaFlow MV Sizing Program to calculate your flow rate range.

Minimum and maximum flow rates for saturated steam (lb/hr)											
Press. (psig)	Nominal pipe size (in.)										
	0.5	0.75	1	1.5	2	3	4	6	8	10	12
5	6.5	12	20	49	82	183	318	722	1264	1988	2813
	52	122	265	650	1087	2431	4231	9594	16806	26429	37395
100	15	27	46	112	187	419	728	1652	2893	4550	6438
	271	639	1386	3405	5690	12729	22156	50233	87998	138386	195803
200	20	37	62	151	253	565	983	2229	3905	6141	8689
	493	1163	2525	6203	10365	23184	40354	91494	160279	252055	356635
300	24	45	74	182	304	680	1184	2685	4704	7397	10466
	716	1688	3664	9000	15040	33642	58556	132763	232575	365747	517499
400	28	51	85	209	349	780	1358	3079	5393	8481	12000
	941	2220	4816	11831	19770	44222	76971	174516	305717	480771	680247
500	31	57	95	233	389	870	1514	3433	6014	9457	13381
	1170	2760	5988	14711	24582	54987	95710	217001	380148	597812	845850

Minimum and maximum flow rates for saturated steam (kg/hr)											
Press. (barg)	Nominal pipe size (in.)										
	15	20	25	40	50	80	100	150	200	250	300
0	3	5	8	19	32	72	126	286	500	786	1113
	18	42	91	274	375	838	1459	3309	5797	9116	12898
5	6	11	18	45	75	167	290	658	1153	1813	2565
	95	224	485	1192	1992	4455	7754	17581	30799	48434	68530
10	8	15	24	59	99	222	387	877	1537	2417	3419
	168	397	862	2118	3539	7915	13777	31237	54720	86053	121758
15	9	17	29	71	119	266	463	1050	1840	2893	4094
	241	569	1236	3036	5073	11347	19750	44779	78444	123360	174543
20	11	20	33	81	136	304	529	1199	2100	3303	4673
	314	742	1610	3956	6611	14787	25738	58355	102226	160761	227463
30	13	24	40	99	165	369	642	1455	2548	4007	5669
	463	1092	2370	5822	9729	21763	37880	85884	150451	236599	334766

Flow rate ranges for air

Refer to the tables below for minimum and maximum flow rate ranges, or use the PanaFlow MV Sizing Program to calculate your flow rate range.

Minimum and maximum flow rates for air @70°F (SCFM)											
Press. (psig)	Nominal pipe size (in.)										
	0.5	0.75	1	1.5	2	3	4	6	8	10	12
0	1.8	3	5	13	22	50	87	198	347	546	773
	18	41	90	221	369	826	1437	3258	5708	8976	12701
100	5	9	15	38	63	141	245	555	972	1529	2163
	138	325	704	1730	2890	6466	11254	25515	44698	70292	99456
200	7	13	21	52	86	193	335	761	1332	2095	2965
	258	609	1322	3248	5427	12140	21131	47911	83931	131895	186752
300	8	15	25	63	104	234	407	922	1615	2540	3594
	380	896	1944	4775	7978	17847	31064	70431	123375	194025	274529
400	10	18	29	72	120	269	467	1060	1857	2920	4132
	502	1183	2568	6309	10542	23580	41043	93057	163000	256358	362724
500	1	20	33	80	134	300	521	1182	2071	3257	4608
	624	1472	3195	7849	13115	28034	51063	115775	203000	318941	451272

Minimum and maximum flow rates for air at 20°C (nm ³ /hr)											
Press. (barg)	Nominal pipe size (in.)										
	15	20	25	40	50	80	100	150	200	250	300
0	3	5	9	21	36	79	138	313	549	863	1221
	28	66	142	350	584	1307	2275	5157	9034	14207	20102
5	7	13	21	52	87	194	337	764	1339	2105	2979
	165	390	847	2080	3476	7775	13533	30682	53749	84525	119596
10	9	17	29	70	117	262	457	1035	1914	2853	4036
	304	716	1554	3819	6381	14273	24844	56329	98676	155178	219563
15	11	21	34	85	142	317	551	1250	2190	3444	4873
	442	1044	2265	5565	9299	20801	36205	82087	143801	297386	319968
20	13	24	40	97	162	363	632	1434	2511	3949	5588
	582	1373	2979	7318	12229	27354	47612	107949	189105	297386	420775
30	16	29	48	118	198	442	770	1745	3057	4807	6801
	862	2034	4414	10843	18119	40529	70544	159942	280187	440621	623439

Dimensional outlines

Remote electronics option - drawing

This option is available on all models. See the drawing below for the dimensions.

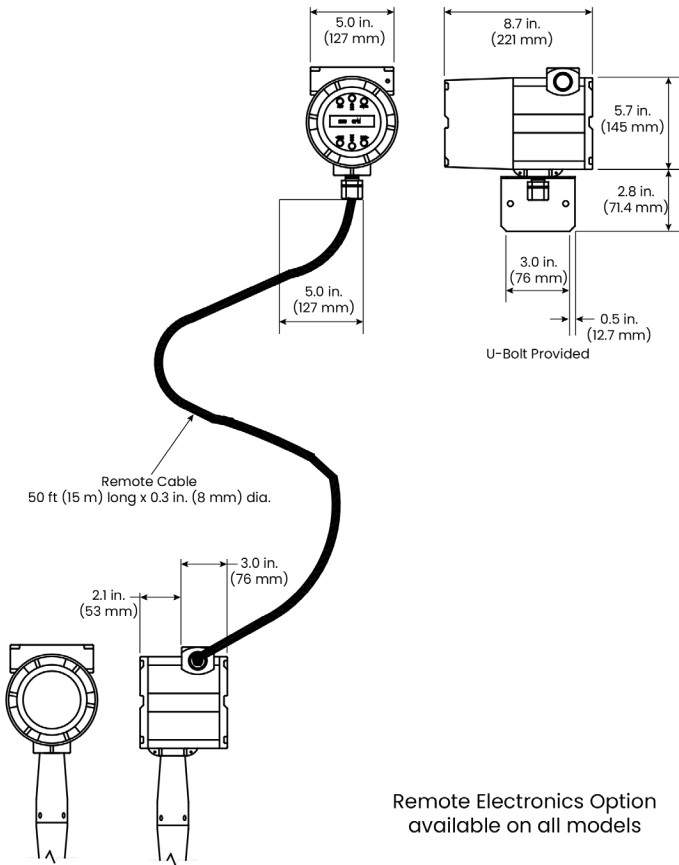

In-line flanged models - table

Flow meter (nominal size)	L	L (ANSI 900)	H	Weight* ANSI 150 (PN 16)	Weight* ANSI 300 (PN 40)	Weight* ANSI 600 (PN 63)	Weight* ANSI 900 (PN 160)
1/2 in. (15 mm)	7.9 in. (200 mm)	7.9 in. (201 mm)	13.5 in. (343 mm)	12.0 lb (5.5 kg)	12.5 lb (5.7 kg)	13.4 lb (6.1 kg)	17.6 lb (8 kg)
3/4 in. (20 mm)	7.9 in. (200 mm)	9.7 in. (247 mm)	13.5 in. (343 mm)	13.0 lb (5.9 kg)	14.6 lb (6.6 kg)	15.6 lb (7.1 kg)	21.0 lb (9.5 kg)
1.0 in. (25 mm)	7.9 in. (200 mm)	10.8 in. (274 mm)	13.5 in. (343 mm)	13.5 lb (6.1 kg)	16.3 lb (7.4 kg)	16.4 lb (7.5 kg)	26.3 lb (11.9 kg)
1.5 in. (40 mm)	7.9 in. (200 mm)	12.0 in. (305 mm)	13.8 in. (351 mm)	16.3 lb (7.4 kg)	23.3 lb (10.6 kg)	24.6 lb (11.2 kg)	37.2 lb (16.9 kg)
2.0 in. (50 mm)	7.9 in. (200 mm)	14.1 in. (357 mm)	14.0 in. (356 mm)	21.2 lb (9.6 kg)	26.8 lb (12.2 kg)	33.2 lb (15.1 kg)	60.5 lb (27.4 kg)
3.0 in. (80 mm)	7.9 in. (200 mm)	14.8 in. (375 mm)	14.6 in. (371 mm)	33 lb (15 kg)	41.0 lb (18.6 kg)	56.1 lb (25.5 kg)	76.5 lb (34.7 kg)
4.0 in. (100 mm)	9.84 in. (250 mm)	16.9 in. (429 mm)	15.1 in. (384 mm)	45.8 lb (20.8 kg)	66.8 lb (30.3 kg)	96.0 lb (43.6 kg)	121.2 lb (55 kg)
6.0 in. (150 mm)	11.81 in. (300 mm)	19.5 in. (495 mm)	16.2 in. (411 mm)	68.3 lb (31.0 kg)	106.3 lb (48.2 kg)	194.3 lb (88.2 kg)	254.4 lb (115.4 kg)
8.0 in. (200 mm)	11.81 in. (300 mm)	22.8 in. (579 mm)	17.2 in. (437 mm)	112.4 lb (51 kg)	168 lb (76.5 kg)	299 lb (136 kg)	433.0 lb (196.4 kg)
10.0 in. (250 mm)	15.0 in. (381 mm)	29.0 in. (737 mm)	18.2 in. (462 mm)	188.3 lb (85.5 kg)	262.3 lb (119.1 kg)	462.3 lb (209.9 kg)	665.9 lb (302.0 kg)
12.0 in. (300 mm)	-	-	-	-	-	-	-

In-line flanged models - drawing

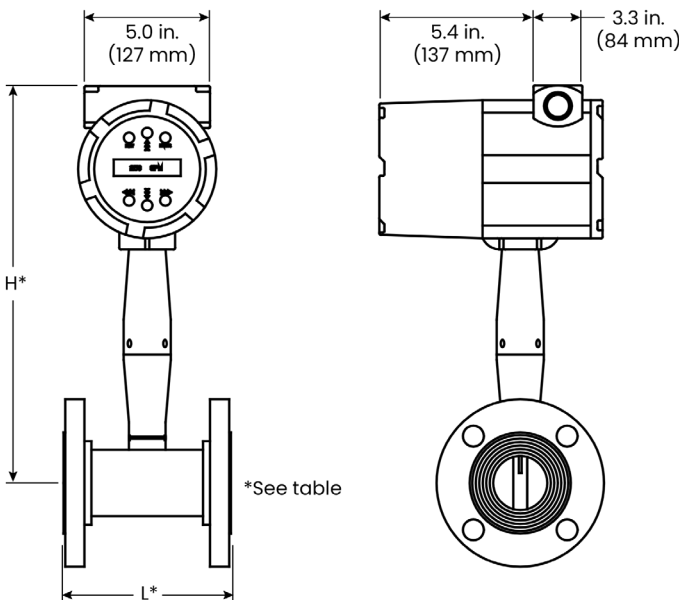

*Add 11 lb (5 kg) for remote electronics

In-line reducing flanged models - table

Flow meter (nominal size)	L	H	Weight* ANSI 150 (PN 16)	Weight* ANSI 300 (PN 40)	Weight* ANSI 600 (PN 64)
3/4 in. (20 mm) x 1/2 in. (15 mm)	7.9 in. (200 mm)	13.5 in. (343 mm)	12.0 lb (5.5 kg)	12.5 lb (5.7 kg)	13.4 lb (6.1 kg)
1 in. (25 mm) x 1/2 in. (15 mm)	7.9 in. (200 mm)	13.5 in. (343 mm)	13.0 lb (5.9 kg)	16.3 lb (7.4 kg)	16.4 lb (7.5 kg)
1-1/2 in. (40 mm) x 1 in. (25 mm)	7.9 in. (200 mm)	13.0 in. (351 mm)	13.4 lb (6.1 kg)	23.3 lb (10.6 kg)	24.6 lb (11.2 kg)
2 in. (50 mm) x 1-1/2 in. (40 mm)	7.9 in. (200 mm)	14.0 in. (356 mm)	16.3 lb (7.4 kg)	26.8 lb (12.2 kg)	33.2 lb (15.1 kg)
3 in. (80 mm) x 2 in. (50 mm)	7.9 in. (200 mm)	14.6 in. (371 mm)	21.2 lb (9.6 kg)	41.0 lb (18.6 kg)	56.1 lb (25.5 kg)
4 in. (100 mm) x 3 in. (80 mm)	9.84 in. (250 mm)	15.1 in. (384 mm)	33 lb (15.0 kg)	66.8 lb (30.3 kg)	96.0 lb (43.6 kg)
6 in. (150 mm) x 4 in. (100 mm)	11.81 in. (300 mm)	16.2 in. (411 mm)	45.8 lb (20.8 kg)	106.3 lb (48.2 kg)	194.3 lb (88.2 kg)
8 in. (200 mm) x 6 in. (150 mm)	11.81 in. (300 mm)	17.2 in. (437 mm)	68.3 lb (31.0 kg)	168 lb (76.5 kg)	299 lb (136 kg)
10 in. (250 mm) x 8 in. (200 mm)	15.0 in. (381 mm)	18.2 in. (462 mm)	188.3 lb (85.5 kg)	262.3 lb (119.1 kg)	462.3 lb (209.9 kg)
12 in. (300 mm) x 10 in. (250 mm)	17.7 in. (450 mm)	19.2 in. (488 mm)	298.6 lb (135.6 kg)	402.6 lb (182.8 kg)	606.6 lb (275.4 kg)

*Add 11 lb (5 kg) for remote electronics

Wafer models - drawing and table

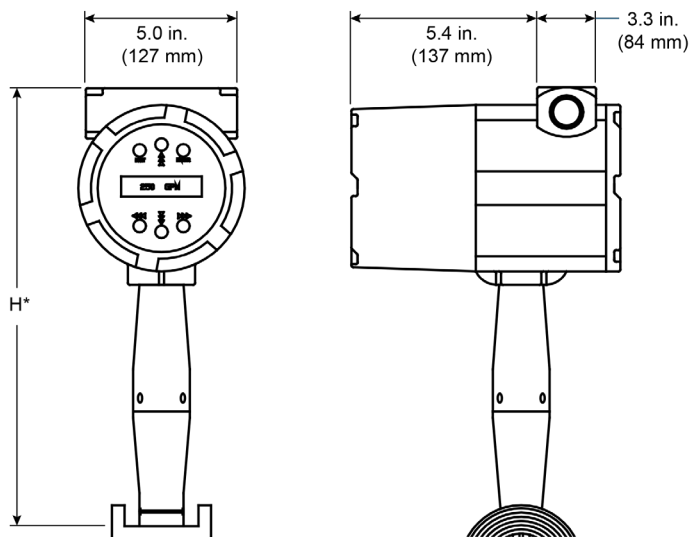

In-line wafer model dimension - table

Flow meter (nominal size)	L	H	Diameter	Weight*
1/2 in. (15 mm)	2.56 in. (65 mm)	13.5 in. (343 mm)	1.38 in. (35 mm)	9.2 lb (4.2 kg)
3/4 in. (20 mm)	2.56 in. (65 mm)	13.5 in. (343 mm)	1.69 in. (43 mm)	9.5 lb (4.3 kg)
1 in. (25 mm)	2.56 in. (65 mm)	13.5 in. (343 mm)	2.0 in. (51 mm)	10.3 lb (4.7 kg)
1-1/2 in. (40 mm)	2.56 in. (65 mm)	13.8 in. (351 mm)	2.88 in. (73 mm)	12.1 lb (5.5 kg)
2 in. (50 mm)	2.56 in. (65 mm)	14 in. (356 mm)	3.62 in. (92 mm)	14.1 lb (6.4 kg)
3 in. (80 mm)	2.56 in. (65 mm)	14.6 in. (371 mm)	5.0 in. (127 mm)	18.7 lb (8.5 kg)
4 in. (100 mm)	2.56 in. (65 mm)	15.1 in. (384 mm)	6.19 in. (157 mm)	23.9 lb (10.8 kg)

*Add 11 lb (5 kg) for remote electronics

In-line reducing wafer model dimension - table

Flow meter (nominal size)	L	H	Diameter	Weight*
3/4 in. (20 mm) x 1 in. (25 mm)	2.56 in. (65 mm)	13.5 in. (343 mm)	1.38 in. (35 mm)	9.2 lb (4.2 kg)
1 in. (25 mm) x 3/4 in. (20 mm)	2.56 in. (65 mm)	13.5 in. (343 mm)	1.69 in. (43 mm)	9.5 lb (4.3 kg)
1-1/2 in. (40 mm) x 1 in. (25 mm)	2.56 in. (65 mm)	13.8 in. (343 mm)	2.0 in. (51 mm)	10.3 lb (4.7 kg)
2 in. (50 mm) x 1-1/2 in. (40 mm)	2.56 in. (65 mm)	13.8 in. (343 mm)	2.88 in. (73 mm)	12.1 lb (5.5 kg)
3 in. (80 mm) x 2 in. (50 mm)	3.9 in. (100 mm)	14.6 in. (371 mm)	5.0 in. (127 mm)	23.9 lb (8.5 kg)
4 in. (100 mm) x 3 in. (80 mm)	4.7 in. (120 mm)	15.1 in. (384 mm)	6.19 in. (157 mm)	35.2 lb (10.6 kg)

*Add 11 lb (5 kg) for remote electronics

PanaFlow MV84 ordering information

Parent Number Code:

- MV84 In-line Multivariable Mass Vortex Flow Meter
- MV84R In-Line Reducing Flange Multivariable Mass Vortex Flow Meter

Feature 1: Multivariable Options

- V Volumetric flow meter for liquid, gas and steam
- VT Velocity and temperature sensors
- VTP Velocity, temperature and pressure sensors
- VT-EM Energy output options
- VTP-EM Energy options with pressure sensor
- VT-EP Velocity and temperature sensors with analog input for pressure
- VTEP-EM Energy option with external pressure sensor

Feature 2: Flow Body

- 04 1/2-inch Nominal Bore (15 mm)¹
- 06 3/4-inch Nominal Bore (20 mm)¹
- 08 1-inch Nominal Bore (25 mm)¹
- 12 1.5-inch Nominal Bore (40 mm)
- 16 2-inch Nominal Bore (50 mm)
- 24 3-inch Nominal Bore (80 mm)
- 32 4-inch Nominal Bore (100 mm)
- 48 6-inch Nominal Bore (150 mm)
- 64 8-inch Nominal Bore (200 mm)
- 80 10-inch Nominal Bore (250mm)
- 96 12-inch Nominal Bore (300mm)

Feature 3: Meter Body Material

- C Carbon Steel
- S 316 Stainless Steel
- H Hastelloy

Feature 4: Process Connection

- 150 ANSI 150# Flange
- 300 ANSI 300# Flange
- 600 ANSI 600# Flange
- W Wafer ANSI 600#
- 16 PN 16
- 40 PN 40
- 63 PN 63
- 150R ANSI 150# Reducing Flange²
- 300R ANSI 300# Reducing Flange²
- 600R ANSI 600# Reducing Flange²

Feature 5: Electronics Enclosure

- L Type 4X enclosure
- R (25) Remote electronics Type 4X, 25 ft (8 m) cable
- R (50) Remote electronics Type 4X, 50 ft (8 m) cable

Feature 6: Display Options

- DD Digital Display and Programming Buttons

Feature 7: Input Power

- DC2 12 to 36 VDC required on 2-wire (loop powered) meters with 1AHL only
- DC4 12 to 36 VDC standard volumetric meter on 4-wire
- AC 100-240 VAC, 50/60 Hz
- DC4POE 12-28 VDC or Power over Ethernet (5 Watts maximum), Requires TCP/IP option

(continued on next page)

¹ 1/2", 3/4", and 1" vortex meters are only available in stainless steel

² reducing flanges are only available in stainless steel

*See on the next page

Feature 8: Output

- 1AHL Loop powered option - one analog output (4-20mA), one pulse, one frequency, HART (DC2 option only)
- 1AH 1AH One analog output (4-20mA), one alarm, one pulse, one frequency, HART (DC4 or AC option only)
- 1AM One analog output (4-20mA), one alarm, one pulse, one frequency, Modbus/RTU (DC4 or AC option only)
- 1AMIP One analog output (4-20mA), one alarm, one pulse, one frequency, Modbus TCP/IP (DC4POE option only)
- 1AB One analog output (4-20mA), one alarm, one pulse, one frequency, BACnet/MSTP (DC4 or AC option only)
- 1ABIP One analog output (4-20mA), one alarm, one pulse, one frequency, BACnet TCP/IP (DC4POE option only)
- 3AH Three analog output (4-20mA), three alarm, one pulse, one frequency, HART (DC4 or AC option only)
- 3AM Three analog output (4-20mA), three alarm, one pulse, one frequency, Modbus RTU (DC4 or AC option only)
- 3AMIP Three analog output (4-20mA), three alarms, one pulse, one frequency, Modbus TCP/IP (DC4POE option only)
- 3AB Three analog output (4-20mA), three alarm, one pulse, one frequency, BACnet/MSTP (DC4 or AC option only)
- 3ABIP Three analog output (4-20mA), three alarms, one pulse, one frequency, BACnet TCP/IP (DC4POE option only)

Feature 9: Process Temperature Options

- ST Standard Process Temperature -40° to 500°F (-40° to 260°C)
- HT High Process Temperature up to 750°F (400°C)

Feature 10: Process Pressure

- P0 No pressure sensor
- P1 Maximum 30 psia (2 bara), Proof 60 psia (4 bara)
- P2 Maximum 100 psia (7 bara), Proof 200 psia (14 bara)
- P3 Maximum 300 psia (20 bara), Proof 600 psia (41 bara)
- P4 Maximum 500 psia (34 bara), Proof 1000 psia (64 bara)
- P5 Maximum 1500 psia (100 bara), Proof 2500 psia (175 bara)

MV84 - V - 08 - C - 150 - L - DD - DC2 - 1AHL - ST - P0 (example part number string)

Accessories

The following accessories are available for the PanaFlow MV84 and may be ordered by adding the suffix listed in the table to the order string.

Suffix	Description
PED	PED compliant system (available in stainless steel only)
MC	Material Certifications, US Mil certs on all wetted parts
PT	Pressure Test certificate
CC	Certificate of Conformance
NC	NACE Certification
O2	Oxygen cleaning
ARM25V	Armored remote 25 ft cable (V meter, R25 selected)
ARM50V	Armored remote 50 ft cable (V meter, R50 selected)
ARM25VTP	Armored remote 25 ft cable (VTP meter, R25 selected)
ARM50VTP	Armored remote 50 ft cable (VTP meter, R50 selected)

Join the conversation and follow us on LinkedIn
[linkedin.com/company/panametricscompany](https://www.linkedin.com/company/panametricscompany)

Copyright 2023 by Panametrics LLC. All rights reserved.

PANA030DS2_R8 (07/2023)