

# Optica™

## Operator's Manual





# Optica™

## General Eastern Dew Point Analyzer

### Operator's Manual

A40238752 G  
April 2022

[panametrics.com](http://panametrics.com)

Copyright 2022 Baker Hughes company.

This material contains one or more registered trademarks of Baker Hughes Company and its subsidiaries in one or more countries. All third-party product and company names are trademarks of their respective holders.

[no content intended for this page]

**Chapter 1. Features and Capabilities**

1.1 Introduction .....1

1.2 Electronics Enclosure .....1

    1.2.1 Front Panel ..... 2

    1.2.2 Input/Output Capability ..... 2

1.3 The System ..... 3

    1.3.1 System Components ..... 3

    1.3.2 System Planning ..... 3

1.4 Sensors ..... 3

    1.4.1 Dew Point Sensors ..... 3

    1.4.2 Temperature Sensor ..... 3

    1.4.3 Pressure Sensor ..... 3

1.5 Theory of Operation ..... 4

    1.5.1 Hygrometer Function ..... 4

    1.5.2 Hygrometer Calibration ..... 5

    1.5.3 Other Hygrometer Applications ..... 5

1.6 The PACER Cycle ..... 6

**Chapter 2. Installation**

2.1 Introduction ..... 7

2.2 Benchtop Optica Installation ..... 7

    2.2.1 Mounting the Benchtop Optica ..... 7

    2.2.2 Using the Rack Mounting Option ..... 8

    2.2.3 Wiring the Benchtop Optica ..... 11

2.3 Wall-Mount Optica Installation ..... 12

    2.3.1 Mounting the Wall-Mount Optica ..... 12

    2.3.2 Wiring the Wall-Mount Optica ..... 13

2.4 Output Wiring ..... 14

    2.4.1 Analog Outputs ..... 15

    2.4.2 Alarm Outputs ..... 16

    2.4.3 Serial Output ..... 18

2.5 Sensor Information ..... 19

    2.5.1 Sampling Lines ..... 19

    2.5.2 Ensuring Heat Transfer ..... 20

    2.5.3 High Dew Point Measurements ..... 20

2.6 Sensor Installation ..... 21

    2.6.1 Model 1111H Sensor ..... 21

    2.6.2 Model D-2 Sensor ..... 21

    2.6.3 Model 1211H Sensor ..... 22

    2.6.4 Model 1311DR Sensor ..... 22

    2.6.5 Model 1311XR Sensor ..... 23

    2.6.6 Model SIM-12H Heated Sensor and Components ..... 25

    2.6.7 Connecting the Sensors ..... 25

**Chapter 3. Operation**

3.1 Introduction ..... 27

3.2 Normal Operation ..... 27

3.3 Operating the VGA Optica ..... 27

3.4 Operating the 4x40 Optica ..... 28

3.5 Network Operation ..... 28

3.6 Process Pressure ..... 29

    3.6.1 Actively Measuring Process Pressure ..... 29

    3.6.2 Manually Entering Pressure ..... 29

    3.6.3 Measuring at a Different Pressure ..... 29

    3.6.4 Scenario 1: Measurement Without Enabling the Process Pressure Feature ..... 30

    3.6.5 Measuring Dew Point ..... 30

    3.6.6 Scenario 2: Measurement Requiring the Process Pressure Feature ..... 31

3.7	Status Line Indications .....	32
3.7.1	Factory Default Settings .....	33
3.8	Sensor Balancing .....	34
3.9	Helpful Hints For Operating the Unit .....	34
3.9.1	Supercooled Dew Points .....	34
3.9.2	Contamination .....	34
3.9.3	Mirror Flooding .....	35
3.9.4	Sample Line Maintenance .....	35
3.9.5	Pressure Effects .....	35

## Chapter 4. Programming the VGA Optica

4.1	Introduction .....	37
4.2	Programming Fundamentals .....	37
4.2.1	The Keys .....	37
4.2.2	Data Entry Fields .....	37
4.3	Units of Measure .....	39
4.4	User Equations .....	39
4.5	Menu 1 .....	41
4.5.1	Analog Outputs .....	41
4.5.2	Pressure Input .....	42
4.5.3	Alarms .....	42
4.5.4	Automatic Cleaning and Balance Function .....	43
4.5.5	Data Fields .....	44
4.5.6	Buzzer/Sound .....	44
4.5.7	Network Menu .....	45
4.5.8	Datalog .....	46
4.6	Menu 2 .....	48
4.6.1	General .....	48
4.6.2	Special .....	49
4.6.3	User Equation .....	49
4.6.4	Communication Parameters .....	49
4.6.5	Serial Output Data .....	50
4.6.6	Set Time & Date .....	51
4.6.7	Restore Defaults .....	51
4.7	Saving Configuration Files .....	52

## Chapter 5. Programming the 4x40 Optica

5.1	Introduction .....	53
5.2	Programming Technique .....	54
5.3	Programmable Functions .....	56
5.3.1	Analog Outputs .....	56
5.3.2	Communication Parameters .....	56
5.3.3	Serial Output Units .....	57
5.3.4	Serial Output Setup .....	57
5.3.5	Alarms .....	58
5.3.6	Data Fields .....	59
5.3.7	Pressure Input .....	59
5.3.8	Automatic Cleaning and Balance Function .....	60
5.3.9	Buzzer and Sounds .....	62
5.3.10	General Settings .....	62
5.3.11	User Equations .....	62
5.3.12	Set Time and Date .....	62
5.3.13	Special .....	63
5.3.14	User Default Settings .....	63
5.3.15	Factory Calibrations .....	63

## Chapter 6. Network-Based Programming

6.1	Introduction .....	65
6.2	Programming Screens .....	65

**Chapter 7. Maintenance**

7.1 Minor Maintenance of Sensor Optics ..... 69  
 7.1.1 Cleaning and Balancing the Sensor Mirror ..... 69  
 7.1.2 Procedure for Cleaning and Balancing the Sensor Mirror ..... 70  
 7.2 Field Replacement of Sensor Mirrors ..... 73  
 7.2.1 Replacing the Sensor Mirror ..... 73  
 7.3 Test and Calibration ..... 74  
 7.4 Troubleshooting ..... 74  
 7.4.1 The Display Doesn't Light Up ..... 74  
 7.4.2 "Service" Appears on the STATUS Display Line ..... 74  
 7.4.3 Incorrect Dew Point Display ..... 75  
 7.4.4 "Balance" Remains on the Status Line ..... 76  
 7.4.5 No Analog Output ..... 76  
 7.4.6 No Serial Output ..... 76

**Appendix A. Specifications**

A.1 Performance ..... 77  
 A.1.1 Accuracy [complete system at 25°C (77°F)] ..... 77  
 A.1.2 Measurement Ranges ..... 77  
 A.1.3 Response Time ..... 77  
 A.2 Functionality ..... 78  
 A.2.1 Analog Outputs ..... 78  
 A.2.2 Digital Output ..... 78  
 A.2.3 Alarms ..... 78  
 A.2.4 Displays ..... 78  
 A.2.5 Power ..... 78  
 A.2.6 Operating Ranges ..... 78  
 A.3 Physical (Bench Mount) ..... 79  
 A.3.1 Dimensions ..... 79  
 A.3.2 Weight ..... 79  
 A.3.3 Shipping Weight ..... 79  
 A.3.4 Environmental ..... 79  
 A.4 Physical (Wall Mount) ..... 79  
 A.4.1 Dimensions ..... 79  
 A.4.2 Weight ..... 79  
 A.4.3 Shipping Weight ..... 79  
 A.4.4 Environmental ..... 79  
 A.5 Optional Accessories ..... 79  
 A.5.1 T-100E ..... 79  
 A.5.2 PT-30A ..... 79  
 A.5.3 PT-300A ..... 79  
 A.6 European Compliance ..... 79

**Appendix B. Humidity Equations and Conversion Chart**

B.1 Introduction ..... 81  
 B.2 Vapor Pressure ..... 81  
 B.3 Humidity ..... 82

**Appendix C. Configuring the Serial Interface**

C.1 Wiring to a Personal Computer ..... 85

**Appendix D. Chilled Mirror Sensors**

D.1 Introduction ..... 87  
 D.2 Depression ..... 87  
 D.3 Measurement Range ..... 88  
 D.4 Comparing Optica Sensor Models ..... 89

**Appendix E. Glossary**

**Appendix F. Automatic Balance (for earlier software versions)**

F.1 Programming Automatic Balance for a VGA Optica ..... 93  
F.2 Programming Automatic Balance for a 4x40 Optica..... 93

**Appendix G. Communicating with the OPTICA Using Ethernet**

G.1 Direct Communication ..... 95  
G.2 Computer Communication..... 95  
    G.2.1 Determining the Available Commands ..... 95  
    G.2.2 Retrieving the Alarm Settings..... 96  
    G.2.3 Retrieving the Alarm Types..... 97  
    G.2.4 Retrieving Supported Units ..... 97  
    G.2.5 Retrieving Labels and Functions..... 98  
    G.2.6 Retrieving Analog Output Information..... 100  
    G.2.7 Retrieving the Measured and Calculated Values ..... 100  
    G.2.8 4X40 Optica Configuration..... 101



## Information Paragraphs

**Note:** *These paragraphs provide information that provides a deeper understanding of the situation, but is not essential to the proper completion of the instructions.*

**IMPORTANT:** These paragraphs provide information that emphasizes instructions that are essential to proper setup of the equipment. Failure to follow these instructions carefully may cause unreliable performance.



**CAUTION!** This symbol indicates a risk of potential minor personal injury and/or severe damage to the equipment, unless these instructions are followed carefully.



**WARNING!** This symbol indicates a risk of potential serious personal injury, unless these instructions are followed carefully.

## Safety Issues



**WARNING!** It is the responsibility of the user to make sure all local, county, state and national codes, regulations, rules and laws related to safety and safe operating conditions are met for each installation.

## Auxiliary Equipment

### Local Safety Standards

The user must make sure that he operates all auxiliary equipment in accordance with local codes, standards, regulations, or laws applicable to safety.

### Working Area



**WARNING!** Make sure that power to the auxiliary equipment is turned OFF and locked out before you perform maintenance procedures on the equipment.

### Qualification of Personnel

Make sure that all personnel have manufacturer-approved training applicable to the auxiliary equipment.

### Personal Safety Equipment

Make sure that operators and maintenance personnel have all safety equipment applicable to the auxiliary equipment. Examples include safety glasses, protective headgear, safety shoes, etc.

### Unauthorized Operation

Make sure that unauthorized personnel cannot gain access to the operation of the equipment.

## Environmental Compliance

### Waste Electrical and Electronic Equipment (WEEE) Directive

Baker Hughes is an active participant in Europe's Waste Electrical and Electronic Equipment (WEEE) take-back initiative, directive 2012/19/EU.

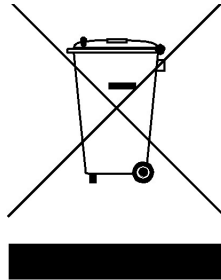

The equipment that you bought has required the extraction and use of natural resources for its production. It may contain hazardous substances that could impact health and the environment.

In order to avoid the dissemination of those substances in our environment and to diminish the pressure on the natural resources, we encourage you to use the appropriate take-back systems. Those systems will reuse or recycle most of the materials of your end life equipment in a sound way.

The crossed-out wheeled bin symbol invites you to use those systems.

If you need more information on the collection, reuse and recycling systems, please contact your local or regional waste administration.

Visit [www.bakerhughesds.com/health-safety-and-environment-hse](http://www.bakerhughesds.com/health-safety-and-environment-hse) for take-back instructions and more information about this initiative.

# Chapter 1. Features and Capabilities

## 1.1 Introduction

The Panametrics *Optica* is a multi-purpose chilled-mirror hygrometer, suitable for use in a wide variety of applications. The *Optica* can function with any Panametrics chilled-mirror sensor to provide the following measurement ranges (depending on the sensor selected):

- Dew/frost point from  $-80^{\circ}\text{C}$  to  $+85^{\circ}\text{C}$  ( $-112^{\circ}\text{F}$  to  $+185^{\circ}\text{F}$ )
- Relative humidity from 0.002% to 100%
- Moisture content from 500 ppb<sub>v</sub> to over  $5.71 \times 10^5$  ppm<sub>v</sub>
- Temperature from  $-100^{\circ}\text{C}$  to  $+100^{\circ}\text{C}$  ( $-212^{\circ}\text{F}$  to  $+212^{\circ}\text{F}$ )

The *Optica* also measures and displays gas pressure using a Panametrics *PT-30A* or *PT-300A* pressure sensor, or a user-supplied 4–20 mA or 0–5 VDC pressure sensor.

**Note:** *If the pressure is known to be constant, a fixed pressure can be programmed, eliminating the need for a pressure sensor.*

Using the *Optica*, you can simultaneously measure and display dew point, temperature and pressure, with a wide variety of units of measure. The *Optica* is Ethernet-ready, so you can access the unit using the Internet for remote monitoring applications. You can use the data logging function to record and upload weeks of data.

## 1.2 Electronics Enclosure

The *Optica* is available in two configurations:

- A benchtop model, with an optional rack-mount adapter available
- A wall-mount unit, housed in a Type 4 enclosure, suitable for industrial environments

See *Chapter 2, Installation*, for details on how to mount the *Optica*.

## 1.2.1 Front Panel

The Optica front panel is shown in *Figure 1* below. The panel includes: a display, an alphanumeric keypad for data entry, ENTER and TAB keys, and four softkeys to the right of the display screen.

Two display options are available:

- A high-resolution, full-color, liquid crystal display (LCD) with data graphing and on-screen programming capability (referred to as the "VGA" unit). See *Figure 1* below.
- A 4-line by 40-character alphanumeric display (referred to as the "4x40" unit).

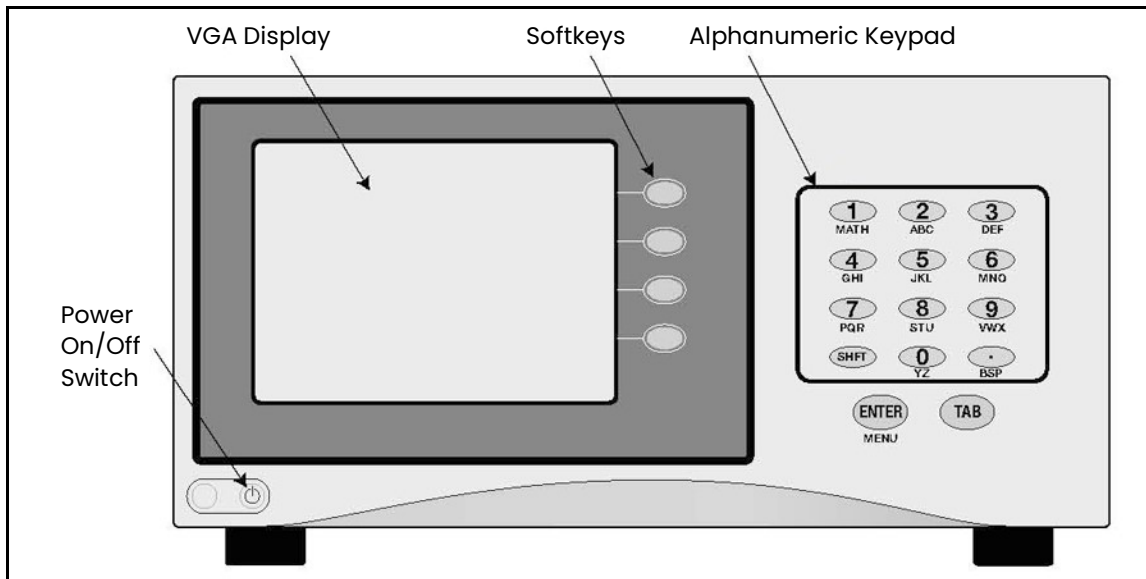

Figure 1: Optica Benchtop Version with VGA Display

## 1.2.2 Input/Output Capability

Available inputs and outputs include the following:

- 4-wire Resistance Temperature Detector (RTD) input
- 4–20 mA and 0–5 VDC Pressure Sensor inputs
- Two simultaneous analog outputs, each with 4–20 mA and 0–5 VDC capability
- Two independent alarm relays (Form C, 5 Amp)
- Serial communications port
- Ethernet 10BaseT (on VGA Optica only)

The *Optica* uses the Panametrics patented *Programmable Automatic Contaminant Error Reduction (PACER)* system for automated self-cleaning and optics rebalancing. Detailed specifications for the *Optica* are given in *Appendix A, "Specifications"*.

## 1.3 The System

### 1.3.1 System Components

A complete *Optica* system consists of the following items:

- Electronic monitor
- Dew point sensor
- Interconnecting sensor cable
- AC line cord
- Certification that the unit is traceable to the National Institute of Standards and Technology (Certificate of Conformance)
- Temperature sensor (optional)
- Pressure sensor (optional)
- Maintenance kit
- User's Manual

### 1.3.2 System Planning

The *Optica* can be used for a wide variety of measurement applications, including the measurement of dew points of gases that are at pressures that exceed the measurement range of Panametrics sensors. In this situation be sure to check "*Process Pressure*" on page 29 for installation planning.

## 1.4 Sensors

The *Optica* can be configured with a chilled-mirror dew point sensor. The specific sensor is chosen according to the expected dew point range and the environment in which the dew point is to be determined. In addition, the *Optica* can be configured with a temperature and/or pressure sensor.

### 1.4.1 Dew Point Sensors

Panametrics offers the following sensors for various applications:

- Model 1111H - Single-stage sensor
- Model 1211H - Two-stage sensor; high pressure and temperature
- Model D-2 - Two-stage sensor
- Model SIM-12H - Two-stage heated sensor
- Model 1311DR - Four-stage, liquid or air cooled sensor
- Model 1311XR - Five-stage, liquid cooled sensor

### 1.4.2 Temperature Sensor

- Model T-100E

### 1.4.3 Pressure Sensor

- Model PT-30A or PT-300A

## 1.5 Theory of Operation

Optical condensation hygrometry is a precise technique for determining the water vapor content in gases by directly measuring dew point or frost temperatures. Using this technique, a metal mirror is cooled until it reaches a temperature at which a thin layer of condensation begins to form on it. The dew layer is detected optically, and the mirror is held at that temperature. The mirror temperature, measured with a platinum resistance thermometer, is an accurate indicator of the dew or frost point. Because these hygrometers are so accurate, they are widely used as a standard in many of the world's metrology laboratories.

### 1.5.1 Hygrometer Function

Figure 2 below illustrates how Panametrics hygrometers detect and measure dew point. The condensate mirror is illuminated with a solid state, infrared emitter (IR). A photodetector monitors the IR light reflected from the mirror. The photodetector is fully illuminated when the mirror is clear of dew, and it receives less light as dew forms. A separate LED and photodetector pair are used as a known reference to compensate for any thermally induced changes in the optical components. The photodetectors are arranged in an electrical bridge circuit, the output current of which is proportional to the light reflected from the mirror. The bridge output controls the electrical current to the thermoelectric cooler.

A large bridge current develops when the mirror is dry, causing the mirror to cool toward the dew point. As dew begins to form on the mirror, less light is reflected, and the bridge output decreases. This, in turn, causes a decrease in cooling current. A rate feedback loop within the amplifier ensures critical response, causing the mirror to stabilize quickly at a temperature that maintains a thin dew or frost layer on the mirror surface. A precision thermometer element embedded within the mirror directly monitors this dew point temperature.

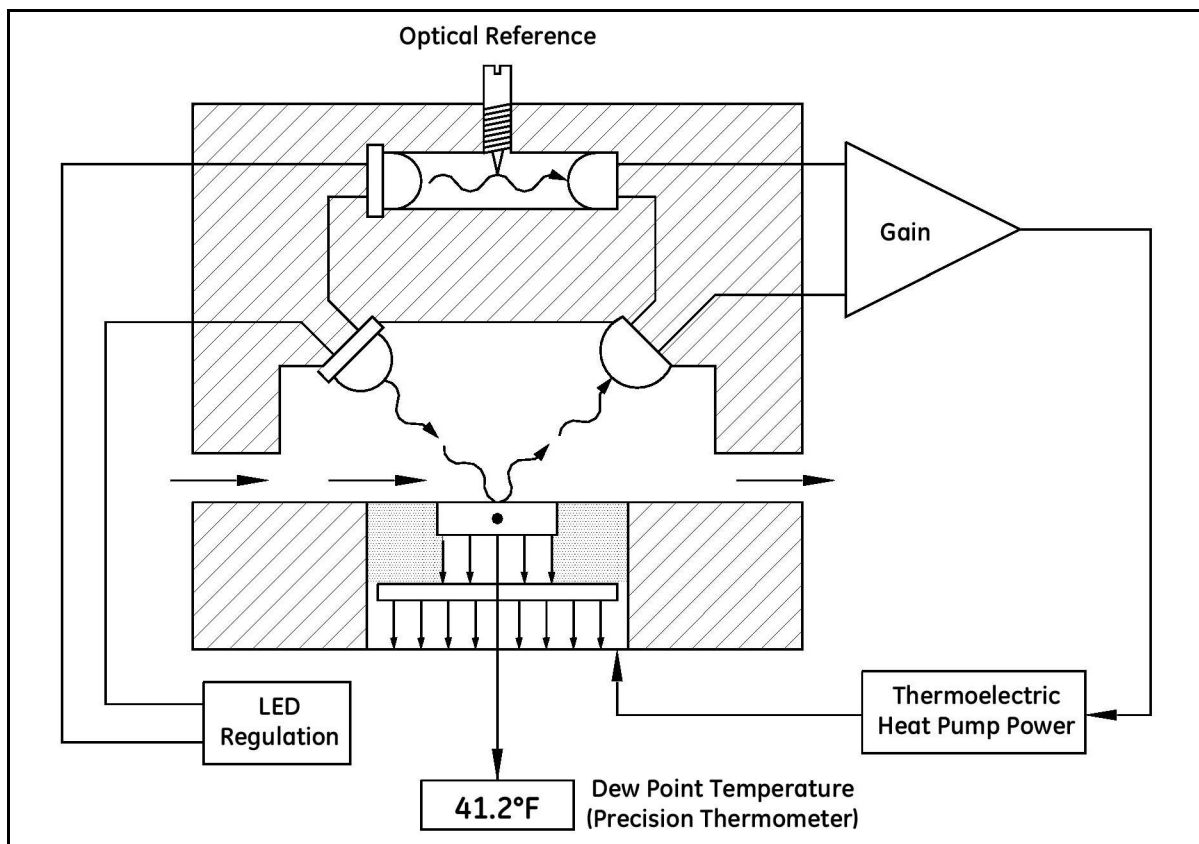

Figure 2: Chilled-Mirror Hygrometer Diagram

### 1.5.2 Hygrometer Calibration

The *Optica* unit can be sent to the *National Institute of Standards and Technology (NIST)* in Gaithersburg, Maryland for certification or to any *National Standards* lab for calibration against their primary humidity standards. A calibrated instrument can then be used as a transfer standard in local laboratories to calibrate lower echelon instruments.



**CAUTION! Field calibration of the Optica is not recommended.**

Hygrometers used as calibration standards must have the following characteristics:

- The mirror thermometer must have suitable long-term accuracy (such as that obtained with a platinum resistance thermometer).

### 1.5.3 Other Hygrometer Applications

Many Panametrics Chilled Mirror Hygrometers are used in industrial applications in addition to metrology. The optical condensation hygrometer is not readily damaged or contaminated by industrial process gases that can degrade other secondary measurement schemes such as saturated salt and polymer-based sensors. If the sensor or sampling components should become contaminated with oils, salts, etc., they can be cleaned without harm to the sensor or impairment to the system accuracy. The performance of the hygrometer can be checked at any time by heating the mirror above the dew point, causing the dew deposit to evaporate, then reclosing the servoloop and checking to see that the system cools and returns to the same dew point.

The Panametrics optical condensation sensors cover a wide range of applications limited only by the heat pumping capabilities of the thermoelectrically-cooled mirror.

At high dew points (up to 100°C), the sensor is limited by the thermal properties of the solid state optical components as well as the thermoelectric heat pump capacity.

In a typical application measuring sub-ambient dew points, a two-stage thermoelectrically-cooled mirror can reach a temperature approximately 65°C lower than an ambient (heat sink) temperature of +25°C. The thermoelectric cooler pumps heat from the mirror into the heat sink. By reducing the temperature of the heat sink with a coolant such as chilled water, or by applying the sensor in a low-temperature condition such as monitoring of a test chamber, even lower dew points can be measured. In meteorological applications where the heat sink temperature is considerably lower, frost points down to -75°C can be monitored.

Four- and five-stage sensors are available for measuring the lowest dew/frost points.

## 1.6 The PACER Cycle

Panametrics has developed and patented a compensation technique called **PACER** (*Programmable Automatic Contaminant Error Reduction*) that is very effective in reducing the *Raoult Effect* error associated with soluble contaminants, particularly for near-ambient dew points. The Optica is equipped with the **PACER** cycle as well as **AUTO** balance as found on earlier models. The user can choose which self-cleaning and balancing routine to run depending on the severity of the contamination.

The **PACER** cycle, diagrammed in *Figure 3* below, begins with a coalescence period, during which the mirror is cooled well below the dew point of the sample gas, condensing out a large amount of water.

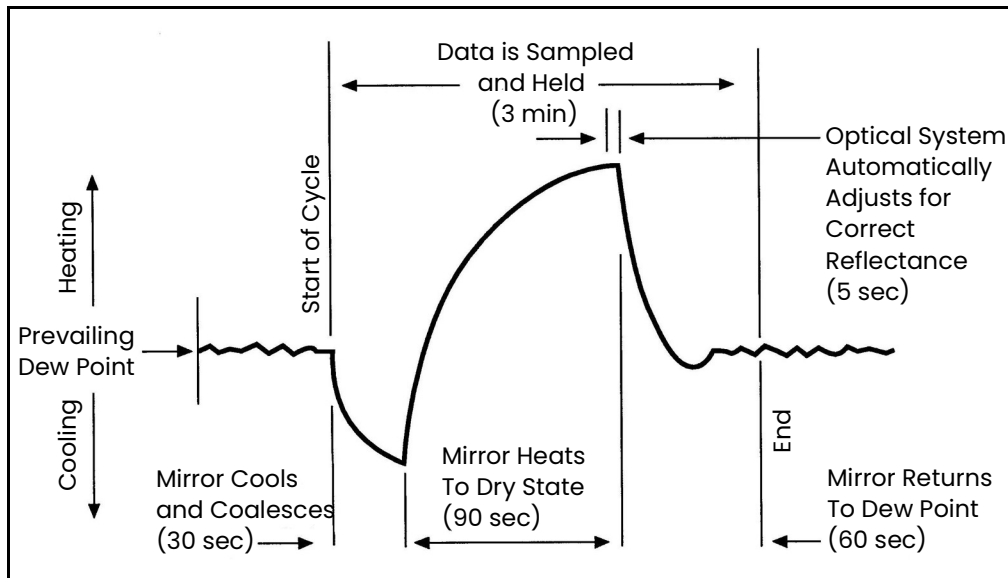

**Figure 3: A Typical PACER Cycle**

This excess water easily dissolves any water-soluble contaminants. The mirror is then heated. During the heating phase, the large puddles of water gradually evaporate, carrying increasingly heavy concentrations of salts as the puddles become smaller. Finally, when all the puddles have evaporated, dry "islands" of crystallized salt are left on the mirror. The area between the islands (80-85% of the mirror surface) is now clean and shiny, whereas before the **PACER** cycle it may have been completely covered. The total amount of contamination has not been reduced, but instead, redistributed as shown in *Figure 4* below, with more clean mirror surface available for dew formation. The reflected light signal is then electronically balanced against the reference.

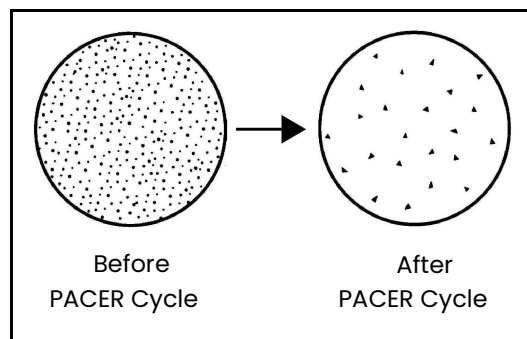

**Figure 4: Results of the PACER Cycle**



## Chapter 2. Installation

### 2.1 Introduction

This chapter explains the installation of the benchtop and wall-mount versions of the *Optica*, the various sensors used with the system and the I/O and power wiring. To install your *Optica*, refer to the instructions and drawings for your specific configuration:

- **Benchtop** - see "*Benchtop Optica Installation*" on page 7
- **Wall-Mount** - see "*Wall-Mount Optica Installation*" on page 12



**WARNING!** To ensure the safe operation of this unit, you must install and operate the *Optica* as described in this manual. In addition, be sure to follow all applicable safety codes and regulations for installing electrical equipment in your area.

### 2.2 Benchtop Optica Installation

#### 2.2.1 Mounting the Benchtop Optica

The *Optica* benchtop dimensions are shown in *Figure 5* below. Two feet on the bottom of the case can be unfolded to raise up the front for easier viewing, if desired.

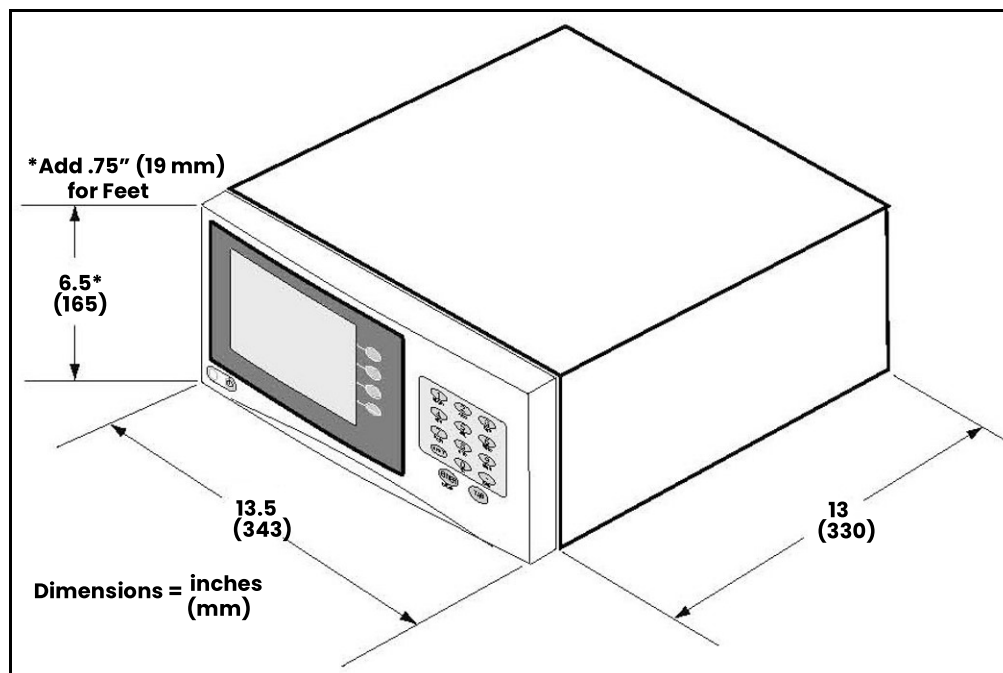
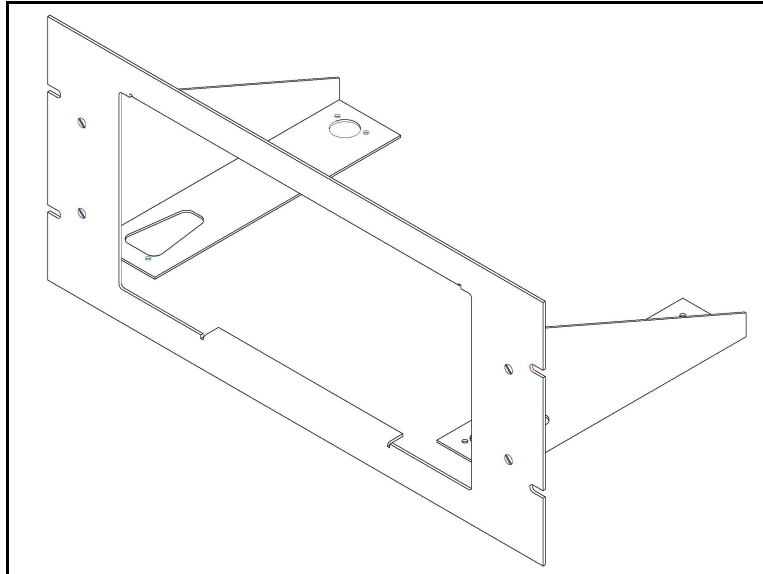

Figure 5: Optica Benchtop Dimensions

## 2.2.2 Using the Rack Mounting Option

There is an optional kit for mounting the benchtop unit in a standard 19-inch rack (see *Figure 6* below, *Figure 7* on page 9, and *Figure 8* on page 10). The two brackets are attached to the front panel using four #8 screws. The *Optica* is mounted to the brackets using the eight mounting holes located just in front of and behind the unit's feet.



**Figure 6: Optica Rack-Mount Adapter**

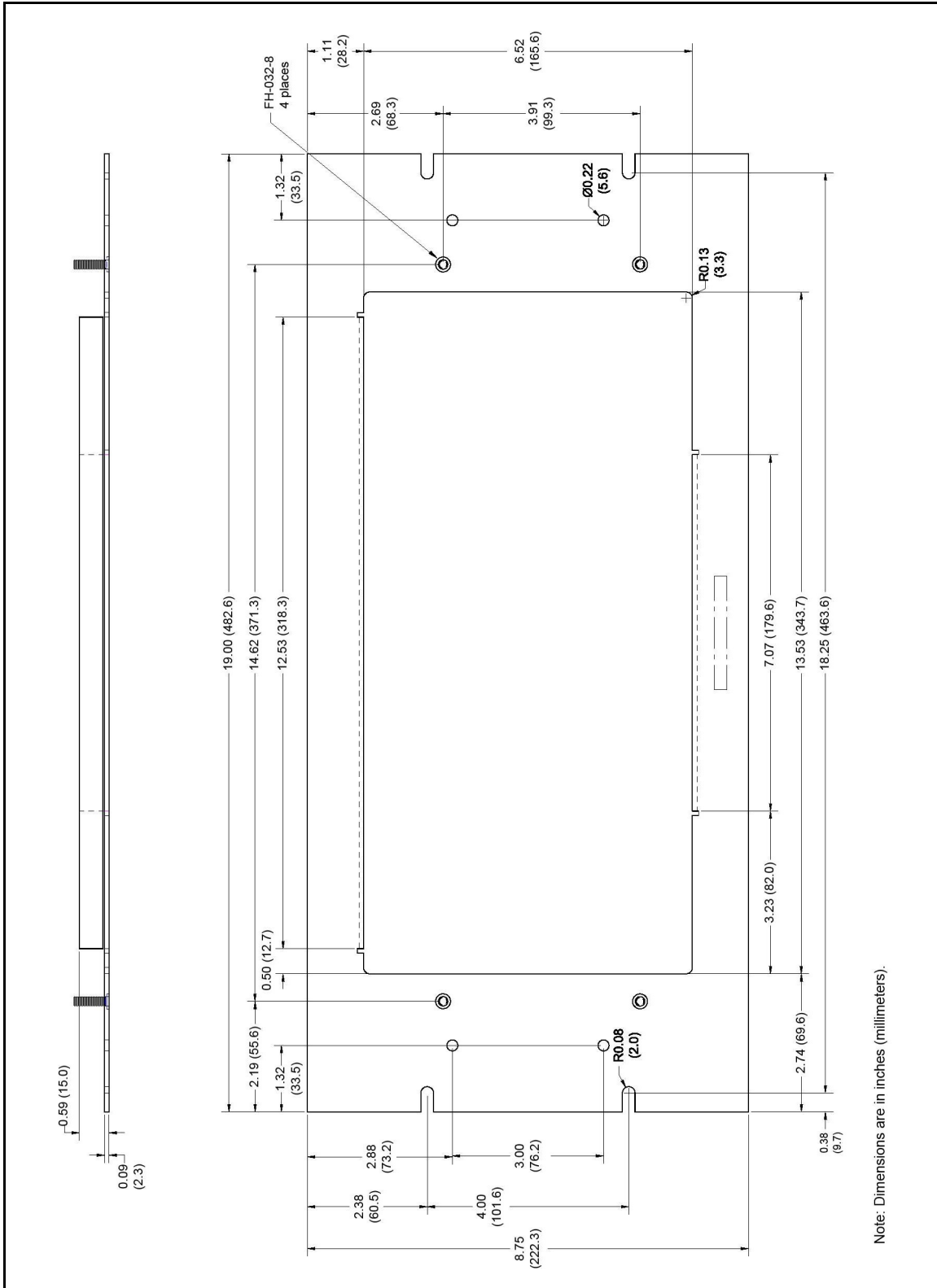

Figure 7: Optica Rack-Mount Adapter - Front Panel

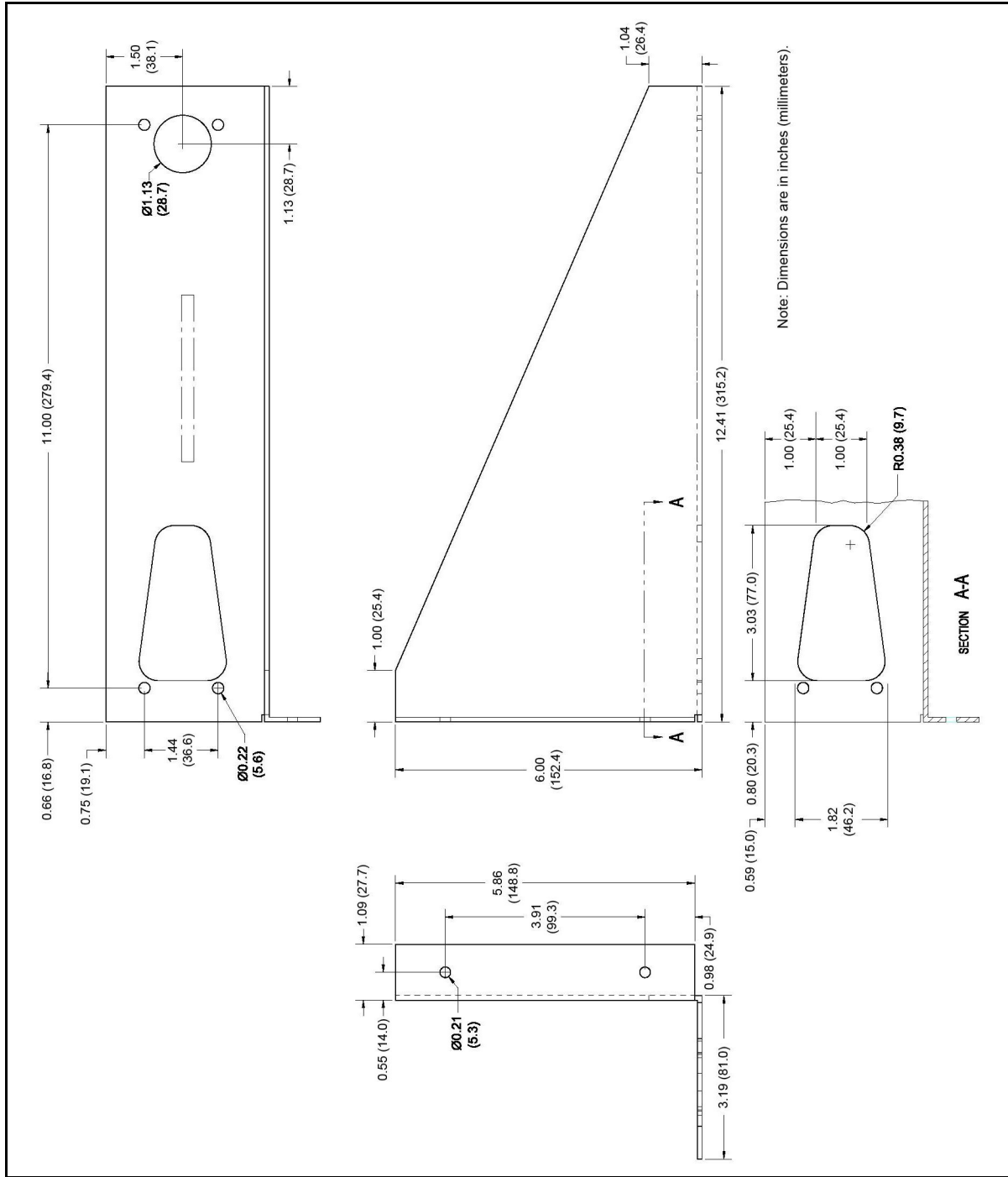

Figure 8: Optica Rack-Mount Adapter - Bracket

## 2.2.3 Wiring the Benchtop Optica

### 2.2.3.1 Input Power

The *Optica* operates with input power from 100 to 120 VAC at 4 amps, or from 200 to 240 VAC at 2.5 amps. It is designed for a nominal 100, 115 or 230 VAC source. A switch on the rear panel selects the appropriate voltage range (see *Figure 9* below).

- The 115 VAC setting operates over a range of 100 to 120 VAC
- The 230 VAC setting operates over a range of 200 to 240 VAC

The *Optica*'s voltage and frequency rating are listed on the rear panel.

### 2.2.3.2 Sensors

Connect the dew point sensor cable to the 25-pin connector in **Slot B** on the *Optica*'s rear panel (see *Figure 9* below). Connect the optional temperature sensor cable to the 9-pin connector in **Slot B** on the rear panel. The optional pressure sensor and other I/O wiring connects to the terminal block in **Slot A**.

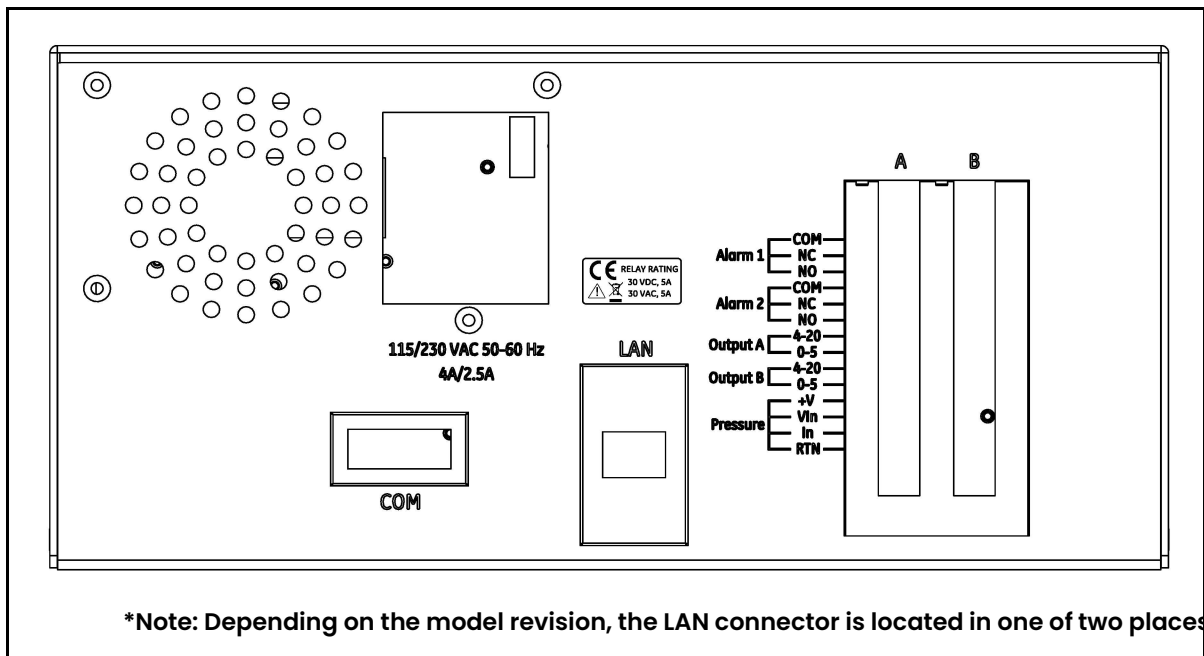

Figure 9: Optica Benchtop Rear Panel

## 2.3 Wall-Mount Optica Installation

The Optica *Wall-Mount* unit is designed to mount on a flat, vertical surface, such as a wall or panel. To mount the wall-mount version, see *Figure 10* and *Figure 11* below.

### 2.3.1 Mounting the Wall-Mount Optica

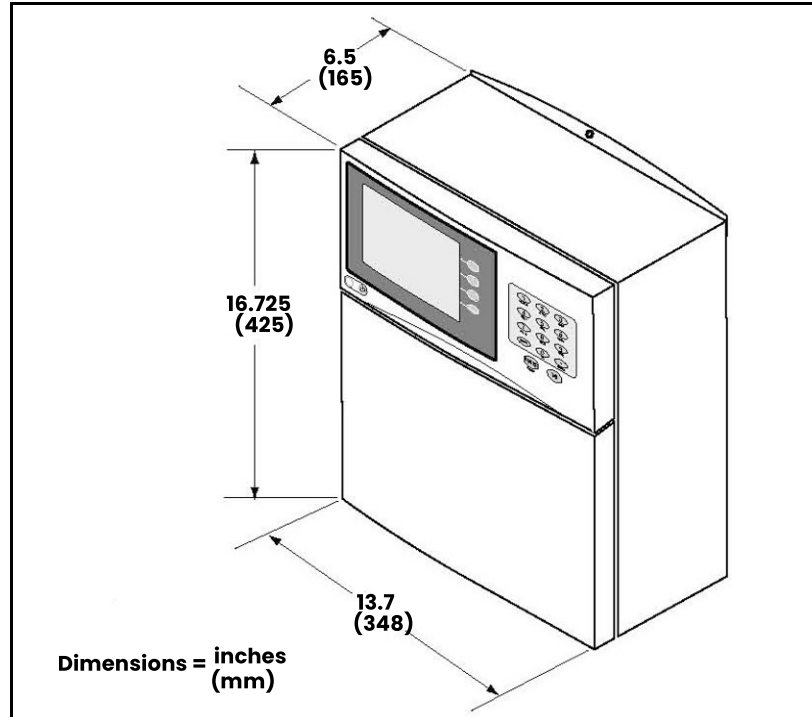

Figure 10: Optica Wall-Mount Unit Dimensions

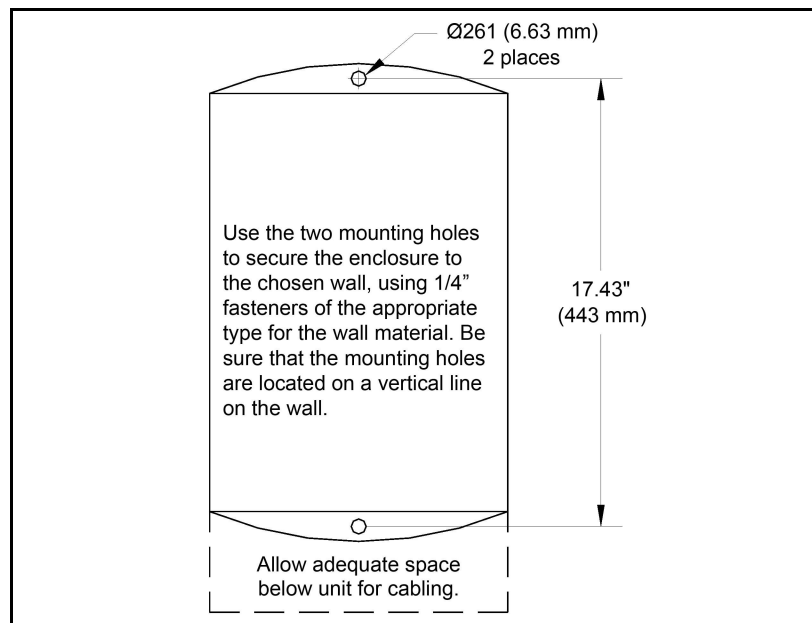
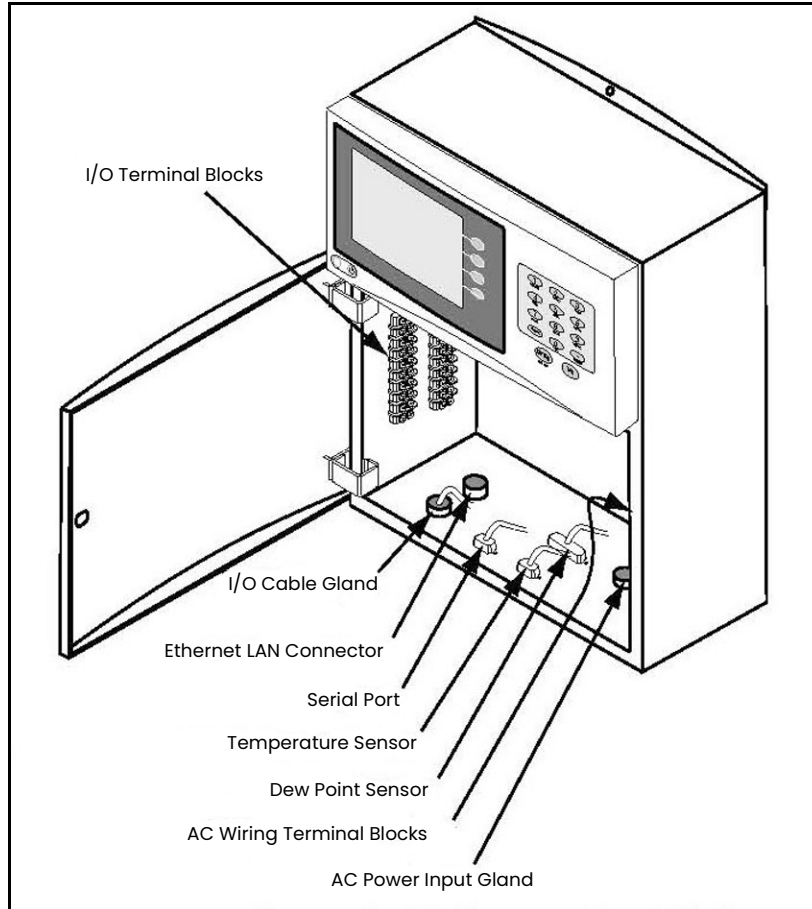

Figure 11: Optica Wall-Mount Unit Mounting Hole Locations

### 2.3.2 Wiring the Wall-Mount Optica

All connections to the wall-mount unit are made through the panel at the bottom of the case as shown in *Figure 12* and *Figure 13* below. Any I/O cabling is brought into the unit through a gland at the lower left of the case and connects to the terminal blocks on the left side of the case. Wiring for these connections is shown in *Figure 15* on page 14. The dew point sensor and temperature sensor cable connectors are located near the center of this panel.



**Figure 12: Wall-Mount Wiring Entrance Locations**

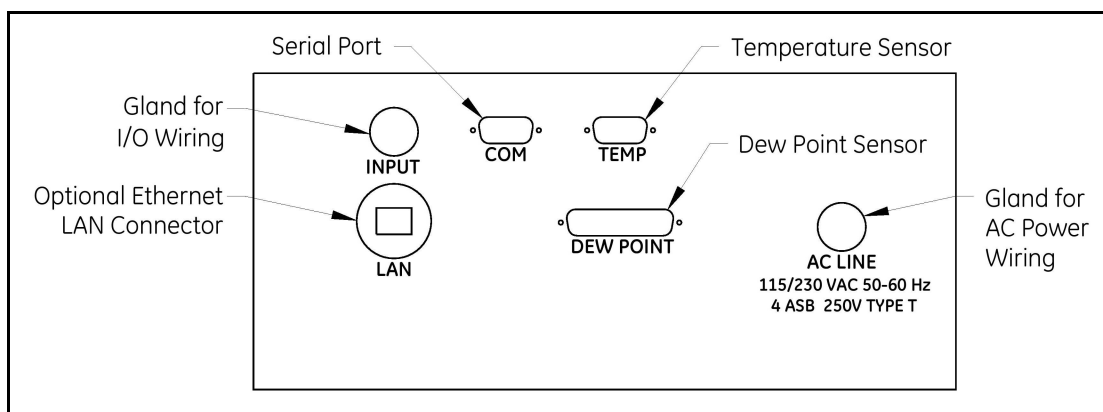

**Figure 13: Wall-Mount Bottom Panel (viewed from bottom of Case)**

### 2.3.2.1 Input Power

Power wiring enters the case through a gland fitting at the lower right of the unit and connects to a screw terminal block mounted on the right side of the case. Wiring of this terminal block is shown in Figure 14 below. The voltage and frequency rating and tolerances, as well as fusing data, are listed on the bottom of the unit.



**WARNING!** There is a potential shock hazard at this location. Disconnect and lock out the main power prior to any service procedures.

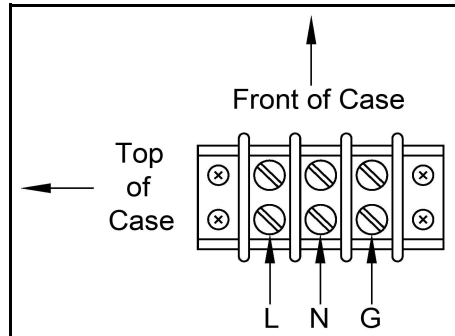

Figure 14: Wall-Mount AC Power Wiring

## 2.4 Output Wiring

The benchtop Optica outputs are connected to removable terminal blocks on the rear panel. *Figure 9 on page 11* shows the location of the benchtop unit terminal blocks and *Figure 15* below shows the **Slot A** connections.

The *Wall-Mount* Optica input/output terminal blocks are located inside the front door as shown in *Figure 12 on page 13*. Cabling is brought in through the gland on the bottom of the unit and wired to the terminal blocks shown in *Figure 15* below.

**Note:** Output programming is described in Chapters 4, 5 and 6.

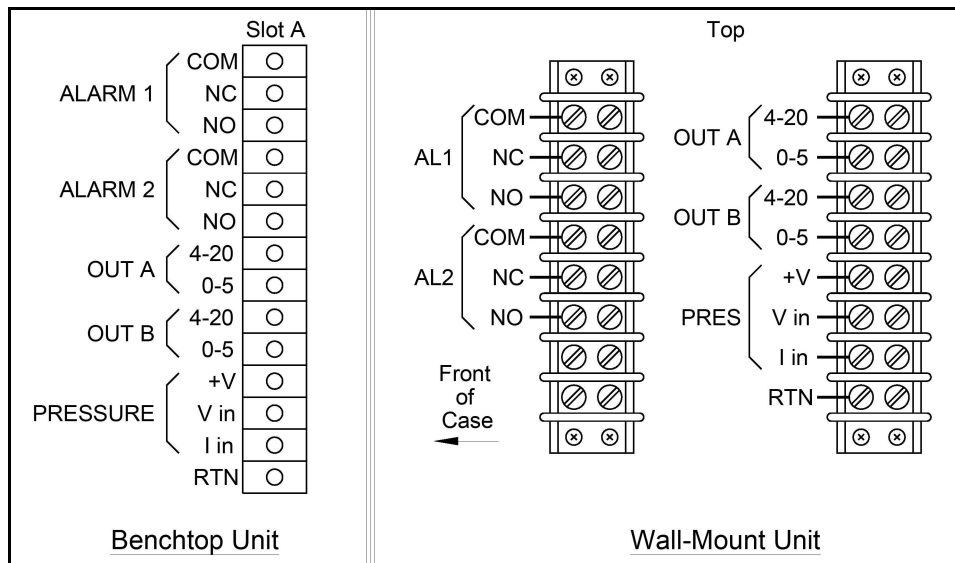

Figure 15: Benchtop and Wall-Mount Input/Output Terminal Blocks



### 2.4.1 Analog Outputs

**Note:** When the Optica is being programmed, the analog outputs provide 4–20 mA and 0–5 VDC signals representing the designated parameters.

- For 4–20mA output, connect to terminals labelled **4–20 (+)** and **RTN (-)**.

**Note:** The maximum load allowed for current output is 500 Ohms.

- For 0–5 VDC output, connect to terminals labelled **0–5 (+)** and **RTN (-)**.

**Note:** The maximum current allowed for voltage output is 5 mA.

#### Example:

Assume a temperature output, scaled to range from 0°C ( $T_{\text{lower}}$ ) to 100°C ( $T_{\text{upper}}$ ), with a measured actual temperature of 23°C ( $T_{\text{actual}}$ ):

The voltage output is calculated by:

$$V_{\text{out}} = \left[ \frac{(T_{\text{actual}} - T_{\text{lower}})}{(T_{\text{upper}} - T_{\text{lower}})} \times 5 \right]$$

yielding an output voltage of 1.15V.

$$\left[ \frac{(23 - 0)}{(100 - 0)} \times 5 \right] = 1.15\text{V}$$

The current output is calculated by:

$$I_{\text{out}}(\text{mA}) = \left[ \frac{(T_{\text{actual}} - T_{\text{lower}})}{(T_{\text{upper}} - T_{\text{lower}})} \times (20 - 4) \right] + 4$$

yielding an output current of 7.68 mA.

$$\left[ \frac{(23 - 0)}{(100 - 0)} \times (16) \right] + 4 = 7.68\text{mA}$$

### 2.4.1.1 Additional Voltage Outputs

It is possible to use either analog current output as an additional voltage output by connecting a precision resistor from the current output to its return. A voltage will be produced equal to the output current times the load resistance. To produce a voltage output range of 1 to 5 volts, connect a 250 ohm resistor (0.1% tolerance recommended).

Using a 250 ohm resistor, the voltage output is calculated by:

$$V_{\text{out}} = \left[ \frac{(T_{\text{actual}} - T_{\text{lower}})}{(T_{\text{upper}} - T_{\text{lower}})} \times (5 - 1) \right] + 1$$

yielding an output voltage of 1.92V for this example.

$$\left[ \frac{(23 - 0)}{(100 - 0)} \times 4 \right] + 1 = 1.92\text{V}$$

### 2.4.2 Alarm Outputs

Each alarm output connects to the contacts of a 5-Amp, Form C (SPDT) relay.

Make connections as follows:

- For normally open contacts, connect to NO and COM.
- For normally closed contacts, connect to NC and COM.

Any available parameter can be used to control an alarm relay by programming the parameter name and its threshold values. An alarm can also be programmed to monitor the state of the Control, **PACER** Balance, or Service indicators. See Chapter 4, 5 or 6 for programming instructions.

Both *Upper* and *Lower* threshold values are programmed for each parameter. These values designate an alarm band. How they are used depends on the programmed alarm type. Details are shown in *"Inner Band Alarm"* on page 17 and *"Outer Band Alarm"* on page 17.

### 2.4.2.1 Set Point Alarm

For the **Set Point** alarm type, the alarm band provides hysteresis to prevent frequent operation of the alarm relay when the parameter is near the specified value. The relay is **activated** when the parameter **exceeds** the upper limit, and **deactivated** when the parameter goes **below** the lower limit.

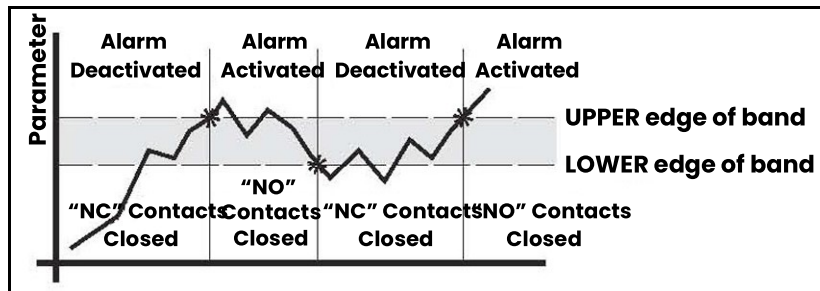

Figure 16: Set Point Alarm

### 2.4.2.2 Inner Band Alarm

For the **Inner Band** alarm type, the alarm relay activates whenever the parameter value is **between** the lower and upper limits.

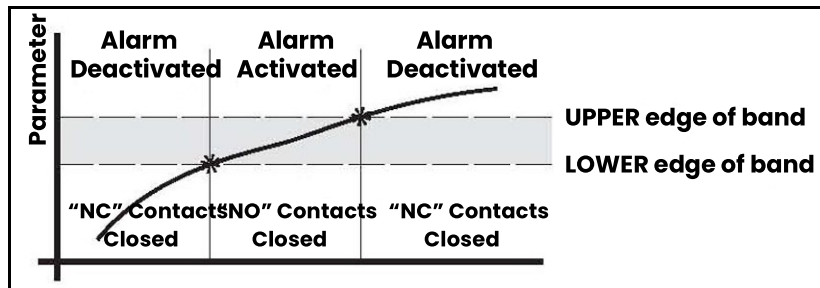

Figure 17: Inner Band Alarm

### 2.4.2.3 Outer Band Alarm

For the **Outer Band** alarm type, the alarm relay activates whenever the parameter value is **greater** than the upper limit or **less** than the lower limit.

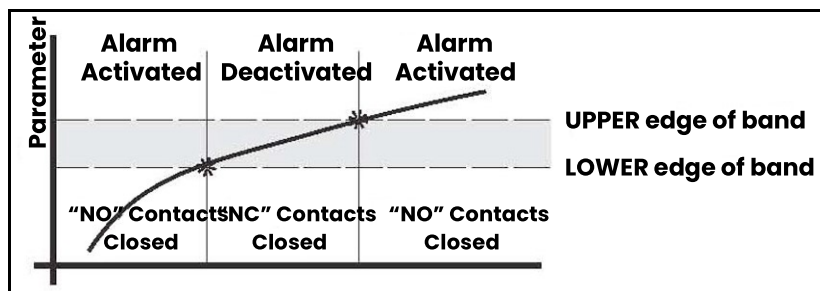

Figure 18: Outer Band Alarm

### 2.4.3 Serial Output

The *Serial Output* connector is located at the lower left of the rear panel of the bench-mount unit, and the bottom panel of the wall-mount unit. The output provides RS-232 serial communications between the unit and a terminal or a PC running in terminal emulation mode.

The connector is a standard 9-pin D connector. For connection to another serial device, the cable is wired as shown in *Table 1* below. For a basic interface without handshaking, only pins 2, 3 and 5 (RX, TX and GND) on the Optica connector are needed. Pin connections are given for both 25-pin and 9-pin devices.

**Table 1: Serial Output Wiring Connections**

Optica Connector		25-Pin Device		9-Pin Device	
Pin	Connection	Pin	Connection	Pin	Connection
2	(RX)	3	(TX)	3	(TX)
3	(TX)	2	(RX)	2	(RX)
4	(DTE)	6	(DSR)	6	(DSR)
5	(GND)	7	(GND)	5	(GND)
6	(DSR)	20	(DTE)	4	(DTE)
7	(RTS)	4	(CTS)	8	(CTS)
8	(CTS)	5	(RTS)	7	(RTS)

The baud rate, format of the data, number of stop bits, number of data bits, and parity can all be programmed using the menus.

## 2.5 Sensor Information

Panametrics produces a variety of sensors compatible with the Optica, ranging from one to five stages of thermoelectric cooling. A comparison chart listing specifications of each sensor is given in *Appendix D. "Chilled Mirror Sensors"*. The following sections provide information on installing the following Panametrics dew point sensors:

- Model 1111H — Single-stage sensor
- Model 1211H — Two-stage sensor; for high pressure and temp.
- Model D-2 — Two-stage sensor
- Model SIM-12H — Two-stage heated sensor
- Model 1311DR — Four-stage heated sensor
- Model 1311XR — Five-stage water-cooled sensor

When selecting a location for installing a sensor, consider the following criteria:

- Locate the sensor as close as is practical to the source of the gas to be measured, to keep the sampling lines as short as possible. This minimizes the system response time and reduces the error rate at low frost points due to sample line outgassing.
- Choose a sensor location that provides access to the dewpoint sample cavity cover, to facilitate periodic mirror cleaning.



### **CAUTION!**

**Never place the sensor in a location where temperatures rise above the maximum rated temperature for the device. See Appendix D. "Chilled Mirror Sensors" for complete sensor specifications.**

### 2.5.1 Sampling Lines

Keep the length of sample tubing between the source and the sensor short, for quick response and highest accuracy. All sampling line compression fittings provided with the sensor are for ¼-inch diameter tubing, unless otherwise specified at the time of order. The material used for the inlet lines can have an important effect on the validity of the readings. Do not use rubber hose or plastic tubing such as PVC or Tygon, because of their hygroscopic nature.

When measuring frost points below  $-30^{\circ}\text{C}$ , sample gas leaving the sensor outlet should be vented through an additional line three to six feet long, since backflow of ambient moisture into the sensor can take place even under positive pressure. Use stainless steel tubing and fittings, and ensure that all plumbing is completely free from leaks.

At dew/frost points above  $-20^{\circ}\text{C}$ , tubing material is not as critical. Copper, PTFE, polypropylene, aluminum or brass tubing and fittings may be used. The sampling system should allow for periodic cleaning. It may be helpful to install a tee and closing valve on the inlet side, to permit the sensor to be shut off while the sampling lines are flushed. At very low humidities, even a trace amount of contamination can alter measured frost point, so cleanliness is particularly important.

## 2.5.2 Ensuring Heat Transfer

Be sure the sensor has an adequate heat sink when operating in hot environments. The sensor must never be allowed to reach a temperature above its rated limit. It is not sufficient merely to ensure that the sensor is in an environment whose temperature is below the rated limit; a means must be supplied to remove heat from the sensor.

When the Model 1111H or D-2 sensors are used at ambient temperatures of 20° to 24°C, full rated depression can be achieved by mounting the sensor on a smooth, thermally conductive surface (such as metal), which tends to remain at the ambient temperature.

If possible, do not operate the sensor continuously at or near full depression. Doing so may decrease the anticipated life of the thermoelectric heat pump.

## 2.5.3 High Dew Point Measurements

### 2.5.3.1 Using Heated Sensors

When measuring dew points at or above the ambient temperature, the sensor must be heated to a temperature of at least 5 to 10°C above the highest anticipated dew point (but not higher than the sensor temperature rating). Some sensors can be mounted on a liquid heat exchanger, or a temperature-controlled electric hot plate, or installed in a heated enclosure. Panametrics recommends closed-loop active control of the elevated sensor body temperature.

The sensor base should be coated with zinc-oxide-filled silicone thermal grease and securely anchored to the heat sink with suitable fasteners. Allow ½ hour for the sensor to reach thermal equilibrium after adjusting the temperature of the heat sink.

The Panametrics **SIM-12H** high temperature sensor is designed for high-temperature applications. It measures dew points above ambient temperature without condensation problems.

### 2.5.3.2 Sample Lines for High Dew Point Measurements

Sampling lines carrying gas to the sensor must be heated and insulated when the dew point of the gas is above the sample line's ambient temperature. The simplest way to achieve this is to use heater tape (either thermostatically controlled, or continuously operating, and sized to provide the required temperature rise). At high temperatures, use stainless steel tubing with adequate insulation to avoid hot and cold sections in the line and to avoid water absorption/desorption cycling as the heater is thermostatically controlled. Heated sampling lines (HSL) are available from Panametrics.

### 2.5.3.3 Filter Requirements

If the gas to be monitored is free from particulates and hydrocarbon liquids or vapor, filtering is not necessary. However, most sample gas streams contain some particulates, and using a filter reduces the need for frequent mirror cleaning. On the other hand, filtering tends to slow the system's response, particularly at low frost points.

The *Series 912* filters manufactured by *Balston Company* (or equivalent) are effective for most applications. For particulates and liquid hydrocarbons, use a Balston *Type DX* filter element.

To filter out very fine particles, the *Type DX* filter can be followed by a *Type BX* filter. A *Type C1* filter can be used to remove hydrocarbon vapors.

If the sample gas is heavily and routinely contaminated, we recommend using a quick-change filter element. Avoid using glass wool, cellulose, and other hygroscopic materials as a filter medium.

### 2.5.3.4 Flow Rate

It is important to have adequate flow through the sensor. Too little flow can slow the response (particularly at very low frost points). Too much flow can cause instability of the control system at high dew points and can reduce the depression capability of the thermoelectric cooler at very low dew points. Too much flow also accelerates the rate of system contamination. A flow rate of 2 to 2.5 ft<sup>3</sup>/h (a little over 1 liter/min) is ideal for most applications. In many cases, flow rates between 0.2 and 5 ft<sup>3</sup>/h (0.1 and 2.5 liter/min) may be used.

## 2.6 Sensor Installation

This section provides installation details for the Panametrics line of chilled-mirror humidity sensors.

### 2.6.1 Model 1111H Sensor

The Model 1111H is an open-type sensor (see *Figure 19* below). It can be threaded into standard pipe fittings or mounted in a type 0111D pressure boss, which encloses it and adapts it for ¼-inch compression fittings. When installing the sensor in the pressure boss, remove the black aluminum sensor cover.

For maximum thermal conductivity, the base of the Model 0111D pressure boss should be coated with heat-conducting grease. When so installed on a surface suitable for dissipating heat, the sensor will achieve its maximum rated depression. See the *Chilled Mirror Sensor Comparison Chart* in *Appendix D. "Chilled Mirror Sensors"*.

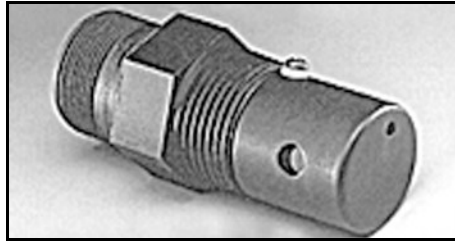

Figure 19: Model 1111H Sensor

### 2.6.2 Model D-2 Sensor

The Model D-2 is a general purpose, two-stage sensor with 65°C (117°F) of depression capability. It features wetted parts of stainless steel and glass, for durability in demanding industrial applications. The Model D-2 can be used as a benchtop sensor, mounted to a heat sink, or mounted to a cooling fan for maximum operating range. Advanced features include field-replaceable optics and cooler assemblies, and auxiliary visible light optics with a viewing window for inspecting the mirror during operation (see *Figure 20* below).

For maximum thermal conductivity, the base of the Model D-2 sensor should be coated with heat-conducting grease. When so installed on a surface suitable for dissipating heat, the sensor will achieve its maximum rated depression. See the *Chilled Mirror Sensor Comparison Chart* in *Appendix D. "Chilled Mirror Sensors"*.

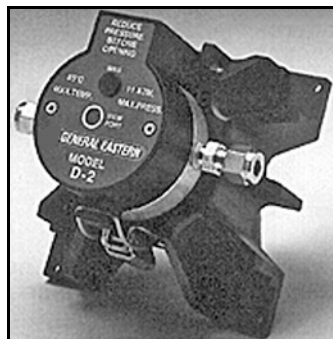

Figure 20: Model D-2 Sensor

### 2.6.3 Model 1211H Sensor

The Model 1211H is a two-stage sensor with 65°C (117°F) of depression capability. It features wetted parts of stainless steel and may be used at higher temperature and pressure than the D2 sensor. The Model 1211H can be used as a benchtop sensor, mounted to a heat sink. Features include a field-replaceable mirror, optics and cooler assembly. See the *Chilled Mirror Sensor Comparison Chart* in *Appendix D. "Chilled Mirror Sensors"*.

### 2.6.4 Model 1311DR Sensor

The 1311DR is a stainless steel, liquid cooled, four-stage sensor suitable for measuring dew points between -75°C and +25°C.

Mount the 1311DR sensor so that the air inlet and exhaust openings are free from obstruction (see *Figure 21* below). If the sensor is liquid cooled, vertical wall mounting is recommended, observing the "UP" arrow on the case. This ensures that condensation forming on cold portions of the 1311DR will drain from the enclosure.

At room temperatures (25°C) with air cooling, dew points from -65°C to +25°C can be measured. When operating it without liquid cooling, switch on the built-in fan. For lower frost point measurements, a chilled-water coolant loop can be used for cooling. Make sure the fan switch is off when using liquid cooling.

Sample flow rates from 0.5 to 5 SCFH (0.25 to 2.5 L/min) should be used.



**CAUTION!** If it can be avoided, do not operate the sensor continuously at or near full depression. Doing so may decrease the life of the thermoelectric heat pump.

Liquid cooling is required for measuring frost points below -65°C (at 25°C ambient), and may be used to create faster response at higher dew point temperatures. If a recirculating chiller is used, it should have a capacity of at least 300 watts at the coolant temperature. Switch the internal fan ON if air cooling is used; leave it OFF for liquid cooling. Install the gas sampling lines according to the instructions listed in *"Sampling Lines"* on page 19.



Figure 21: Model 1311DR Sensor



## 2.6.5 Model 1311XR Sensor

The 1311XR is a stainless steel, water cooled, five-stage sensor (see *Figure 22* below) that can measure frost points as low as  $-80^{\circ}\text{C}$ . The sample gas flow rate should be between 1 and  $5\text{ ft}^3/\text{h}$ . The maximum permissible coolant temperature is  $+50^{\circ}\text{C}$ ; the minimum is  $-10^{\circ}\text{C}$ . A minimum coolant flow rate of 0.1 gallons per minute must be maintained for most dew point measurements. If the fourth stage power supply control is set below  $-65^{\circ}\text{C}$ , the minimum coolant flow rate is 0.25 gal/min. The coolant temperature affects the maximum dew/frost point depression. For frost points of  $-80^{\circ}\text{C}$ , coolant temperature should be below  $20^{\circ}\text{C}$ .



Figure 22: Model 1311XR Sensor

### 2.6.5.1 Electrical Connections

All the electrical connectors on the Model 1311XR dew/frost point sensor are unique. The cables supplied with the sensor can only interconnect the system in one way. Connect the cables as follows:

1. Plug the instrument into a 115/230 VAC power outlet.
2. Connect the 37-pin round black connector on the back of the instrument to the 19-pin military-style connector on the back of the 1311XR sensor.
3. Connect the 17-pin military style connector on the back of the 1311XR sensor to the 24-pin round connector on the back of the heat pump controller module.
4. Connect the 9-pin round connector on the back of the heat pump controller module to the 8-pin rectangular connector on the back of the fourth stage heat pump power supply.
5. Plug the heat pump power supply into a 115/230 VAC outlet.

### 2.6.5.2 Coolant

Connect the two  $3/8$ -inch brass compression fittings on the back of the 1311XR sensor to the coolant lines. Do not run the instrument without sufficient coolant flow.

Suitable coolants include water, glycol and other noncorrosive liquids. The coolant can be recirculated liquid or tap water that is cooled or chilled. If a recirculating chiller is used, it should have a capacity of at least 600 watts at the coolant temperature.

### 2.6.5.3 Sample Gas Fittings

The 1311XR sensor has  $1/4$ " stainless steel compression fittings for sample gas inlet and outlet at the back of the sensor chassis.

### 2.6.5.4 Heat Pump Controller Settings

The 1311XR's heat pump controller module has the following settings:

**Table 2: Model 1311XR Heat Pump Controller Settings**

Setting	Function
AUTO	When set to <b>AUTO</b> , the system operates fully automatically, controlling the heat pump in response to any dew/frost point within its operating range. In <b>AUTO</b> mode, the controller senses the current supplied by the Optica to the top two stages of the thermoelectric coolers. The controller switches on the fourth stage power supply, as required to maintain the mirror temperature at the dew/frost point.  The <b>AUTO</b> setting is recommended for most applications.
Below $-55^{\circ}\text{C}$	If the frost point is known to be below $-55^{\circ}\text{C}$ , the switch can be set to this position to provide slightly faster response than the <b>AUTO</b> setting. However, depression is limited at this setting. If frost points approaching $-80^{\circ}\text{C}$ are to be measured, use the <b>AUTO</b> setting.
$-65^{\circ}\text{C}$ to $-10^{\circ}\text{C}$	If the dew/frost point is known to be between $-65^{\circ}\text{C}$ and $-10^{\circ}\text{C}$ , the switch can be set to this position to reduce overshoot and settling time.
Above $-25^{\circ}\text{C}$	If the dew/frost point is known to be above $-25^{\circ}\text{C}$ , the switch can be set to this position to reduce overshoot and settling time.

**Note:** *The third-stage power indicator may blink in any setting. This is normal.*

### 2.6.5.5 Fourth-Stage Power Supply Control Knob

The control knob on the 1311XR's fourth-stage power supply sets the power consumption limit and the coolant requirement when measuring dew/frost points using the **AUTO** or **BELOW**  $-55^{\circ}\text{C}$  settings. Set this knob to the lowest anticipated dew/frost point.

If the control is set lower than necessary, the system dissipates excess power and requires additional cooling to remove the extra heat generated. If the setting is too high, the system may not be able to reach the true dew/frost point.

To allow the 1311XR sensor to act as a turnkey system (whereby it will cover its entire range automatically), set the switch to **AUTO** and the power supply control knob to the  $-80^{\circ}\text{C}$  position.

### 2.6.5.6 Heat Pump Controller Error Indicators

The heat pump controller module has two overheat indicators connected to thermal shutdown switches. If either indicator comes on, check for and correct any problems before continuing operation. Check the cable connections, coolant flow and coolant temperature.

### 2.6.5.7 Purging the Sensor



#### **CAUTION!**

**The 1311XR must be purged after each use, either with the sample gas after measuring it, or with another dry gas source. Otherwise, condensation inside the sensor housing may cause corrosion and eventual failure of the thermoelectric coolers.**

For extremely dry gas measurements, the 1311XR sensor enclosure must be purged with a gas having a frost point lower than  $-20^{\circ}\text{C}$ . For intermediate temperatures, any gas having a frost point at least as low as the sample gas can be used. The sample gas outflow from the sensor can be used for this purpose, if it is suitable (non-explosive, non-lethal, etc.). Introduce the purge gas to the enclosure via the purge fitting on the rear of the sensor. The simplest method for purging is to run the sample gas outflow through the U-tube supplied with the sensor.

## 2.6.6 Model SIM-12H Heated Sensor and Components

The SIM-12H heated sensor module is suitable for measuring dew/frost points between  $-10^{\circ}\text{C}$  and  $+85^{\circ}\text{C}$ . It contains precision heating, as well as cooling, capability. Three separate heaters are located in the sensor walls, 120 degrees apart. Three temperature sensors measure the body temperature at those points, and three control circuits precisely adjust the temperature of each heater. Any detected temperature gradient across the sensor cavity is immediately eliminated, resulting in very even control. All three heaters are controlled by the temperature set by the front panel selector knob. The sensor is a two-stage unit, providing  $65^{\circ}\text{C}$  of depression capability, and  $60^{\circ}\text{C}$  actual measurement range.

### 2.6.6.1 Type SIM-HFT Heated Filter Module

The SIM-HFT heated filter module allows the sample gas to be purged of particulate contaminants prior to entering the sensor. The incoming gas is first passed through a 90-micron prefilter, then a 15-micron final filter. All parts in contact with the sample are heated to a constant  $105^{\circ}\text{C}$ , eliminating any possibility of condensation. The sintered filters are easily removed for cleaning or replacing if required.

### 2.6.6.2 Type SIM-HFM Heated Flow Meter

The SIM-HFM heated flow meter module allows the sample gas flow rate to be both measured and controlled at a rate that is optimum for the sensor. A metering valve mounted on the front panel allows control over a range of 0 to  $2\text{ ft}^3/\text{h}$ . All parts in contact with the sample gas are heated to a constant  $105^{\circ}\text{C}$ , so that no condensation occurs. The flow meter is normally mounted downstream from the heated sensor.

### 2.6.6.3 Type SIM-HSL Heated Sampling Line

The SIM-HSL heated sampling line is self-regulated at a temperature high enough to ensure that no condensation occurs. The line is made of  $\frac{1}{4}$ -inch outside diameter PTFE, with stainless steel fittings.

### 2.6.6.4 Type SIM-MPL Mounting Plate

The SIM-MPL mounting plate is designed to accept one, two or three heated modules: the heated sensor, the heated filter, and the heated flow meter. The mounting plate provides a convenient method of wall-mounting the entire heated sampling system. When ordered with one or more modules, the factory performs all mounting, plumbing and wiring work, thus providing a complete system ready for installation.

## 2.6.7 Connecting the Sensors

Dew point, temperature and pressure sensors provided by Panametrics for the Optica monitor are pre-wired with connectors installed. Plug these connectors into their corresponding sockets as shown in *Figure 9 on page 11* for the benchtop unit, or *Figure 12 on page 13* for the wall-mount unit.

[no content intended for this page]

## Chapter 3. Operation

### 3.1 Introduction

Operating instructions fall into three categories:

- Normal Operation - Using the unit's controls.
- Setup and Programming - Customizing the unit for specialized applications (not required for many conventional applications).

**Note:** *The unit is shipped pre-programmed to meet typical requirements. The factory default settings are listed in Table 4 on page 33. Complete programming instructions are given in Chapters 4, 5, and 6.*

- Maintenance - Manually testing the unit's cooling capacity, cleaning the mirror, and other operations that might be required on a regular basis, or when a problem is suspected, depending on the application. Details are given in Chapter 7. "Maintenance".

### 3.2 Normal Operation

Normal operation of the Optica is very simple. To turn the unit on, check that the main power switch on the rear of the benchtop unit is set to ON (—), then press the right-hand side of the power switch (located at the lower left corner on the front of the unit).

The Optica begins its power-up sequence, which lasts about a minute. The unit's software version is displayed on the initial screen. The status line displays Initializing. Next, the Optica performs a PACER balance. The PACER balance typically requires five to fifteen minutes, depending on the sensor chosen and the humidity of the sample gas during the balance cycle. The status line displays Balance Acquiring.

Once the balance cycle is completed and the unit reaches steady state, Control is displayed in the status bar at the bottom of the screen.

The sensor can be controlled using the softkeys to the right of the display, shown on the screen in *Figure 23 on page 27*. The operator can manually heat or cool the sensor, or initiate a PACER balance cycle.

### 3.3 Operating the VGA Optica

The parameters chosen during programming are displayed numerically in the top half of the screen, and graphically at the bottom (see *Figure 23* below). To program the unit, see *Chapter 4. "Programming the VGA Optica"*.

A balance indicator is shown as a vertical bar on the right side of the screen. It shows the state of the feedback control loop controlling the mirror temperature. When the system reaches steady-state (the Control status indicator is displayed), the balance indicator should be near the center of its range. If the balance indicator is near the top or bottom of its range, the dew point sensor may need to have its optics signal level adjusted (see *"Minor Maintenance of Sensor Optics"* on page 69).

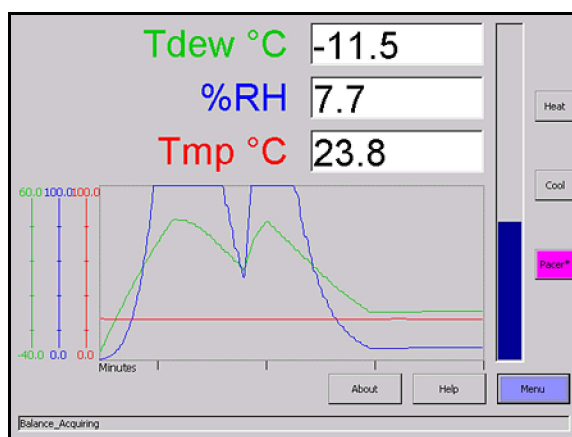

Figure 23: Typical VGA Display Screen

### 3.4 Operating the 4x40 Optica

The parameters chosen during programming are displayed numerically on the top three lines of the display. For programming, see *Chapter 5. "Programming the 4x40 Optica"*. A typical 4x40 display screen is shown below. The system status is shown at the lower left, and the balance indicator is shown at the lower right.

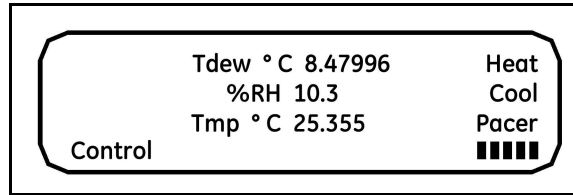

Figure 24: Typical 4x40 Display Screen

### 3.5 Network Operation

The VGA Optica can be operated and programmed remotely over a network. Networked operation is very similar to operation using the front panel. For programming from a network, see *Chapter 6. "Network-Based Programming"*. A typical network screen is shown in *Figure 25* below.

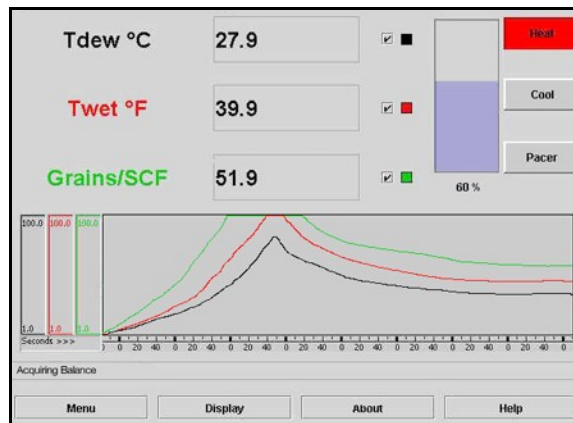

Figure 25: Typical Network Screen

## 3.6 Process Pressure

The Optica provides several ways of measuring or specifying sample gas pressure (needed for pressurized humidity measurements). You can do one of the following:

- Actively measure the pressure at the dew point sensor
- Manually enter the pressure, if it is known and stable
- “Sample-off” a high-pressure gas sample for measurement at a lower pressure (usually atmospheric) and let the Optica calculate dew point at the process pressure.

**For example:** a sensor with a maximum pressure rating of 300 psi cannot be subjected to a process pressure of 500 psi. A sampling system can be arranged to allow the measurement to be made at atmospheric pressure. The Optica can then calculate and display the dew point at the process pressure (see “*Scenario 2: Measurement Requiring the Process Pressure Feature*” on page 31).

### 3.6.1 Actively Measuring Process Pressure

Use this method when the process pressure is within the specifications of the dew point sensor and can be measured directly. In the *Pressure Input* menu, set the Pressure Input to V or I as appropriate for the pressure sensor. Set the *Process Pressure Status* to Disabled.

**Note:** *The pressure measured by the pressure sensor will be used to compute the vapor pressure.*

### 3.6.2 Manually Entering Pressure

Use this method when the process pressure is a known and fixed value, and will not be actively measured. In the *Pressure Input* menu, set the Pressure Input to Use Default. Enter the pressure into the *Default* field. Set the *Process Pressure Status* to Disabled.

**Note:** *The default pressure entered will be used to compute the vapor pressure.*

### 3.6.3 Measuring at a Different Pressure

Use this method when the humidity must be measured at a pressure that is lower or higher than the process pressure, but the reported value must represent the humidity at the process pressure. “*Scenario 2: Measurement Requiring the Process Pressure Feature*” on page 31 gives examples of programming the Optica for this situation.

**Note:** *The process pressure is entered manually and the humidity sensor pressure may be measured or manually entered.*

Examples of the use of the *Process Pressure* menu are shown in the following sections.

### 3.6.4 Scenario 1: Measurement Without Enabling the Process Pressure Feature

Process pressure is 100 psi, within the range of a typical Panametrics chilled mirror sensor. Since vapor pressure and dew point are pressure-dependent, a flow meter is installed downstream of the sensor to assure that the sensor cavity is at the process pressure (see *Figure 26* below).

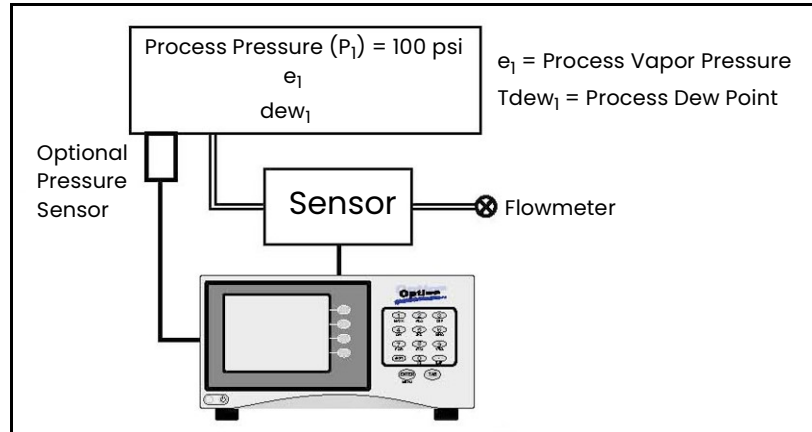

Figure 26: Measurement Scenario 1

#### 3.6.4.1 Measuring Vapor Pressure Without a Pressure Sensor

To measure vapor pressure without a pressure sensor, make the following entries in the *Pressure Input* menu section for this example:

- Input: Use Default
- Units: psia
- Default: 100
- Process Status: Disabled

#### 3.6.4.2 Measuring Vapor Pressure With a Pressure Sensor

To measure vapor pressure with a 4–20 mA, 0–30 psia pressure sensor, connect the sensor to the Optica's terminal block and make the following entries in the *Pressure Input* menu:

- Input: In 4–20
- Units: psia
- Upper: 30.00
- Lower: 0.00
- Process Status: Disabled

### 3.6.5 Measuring Dew Point

In this scenario, dew point can be measured without knowledge of the gas pressure. Connect the equipment as shown in *Figure 26* above, with or without a pressure sensor, and follow the normal operating procedures.



### 3.6.6 Scenario 2: Measurement Requiring the Process Pressure Feature

Process pressure is 500 psi, above the measurement range of a typical Panametrics chilled mirror sensor. A flowmeter is installed upstream of the sensor cavity to expand the gas to be within the measurable range of the dew point sensor. Since we wish to measure the dew point of the process gas and dew point is pressure dependent, an accurate dew point measurement at the process pressure requires accommodating the expansion to the sensor cavity pressure by using the Optica's *Process Pressure* feature (see *Figure 27* below).

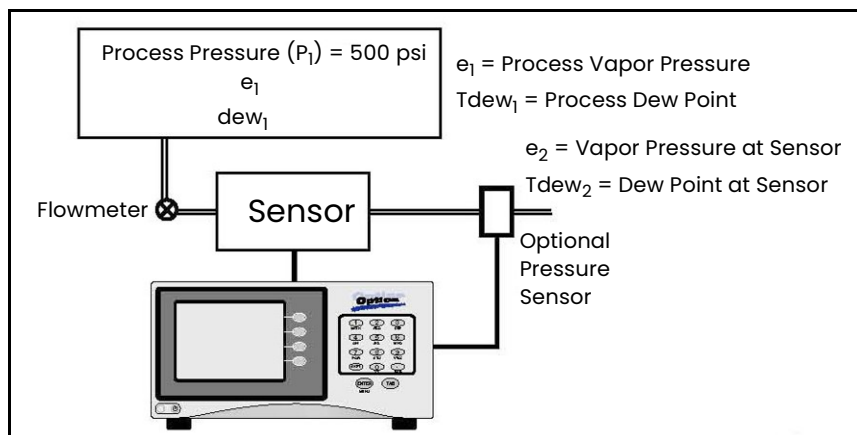

Figure 27: Measurement Scenario 2

#### 3.6.6.1 Measuring Vapor Pressure Without a Pressure Sensor

To measure vapor pressure without a pressure sensor, make the following entries in the *Pressure Input* menu section for this example:

- Input: Use default
- Units: psia
- Default: 14.7 (the pressure at the dew point sensor)

In addition, to accommodate the pressure expansion, the following entries are required in the *Process* section:

- Status: enabled
- Pressure: 500 (specify the process pressure with the same units as the default pressure specified above)

#### 3.6.6.2 Measuring Vapor Pressure With a Pressure Sensor

To measure vapor pressure with a 4–20 mA, 0–30 psia pressure sensor, connect the equipment as shown above and make the following entries in the *Pressure Input* menu section:

- Input: In 4–20
- Units: psia
- Upper: 30.00
- Lower: 0.00

In addition, to accommodate the pressure expansion, the following entries are required in the *Process* section:

- Status: enabled
- Pressure: 500 (specify the process pressure with the same units as the default pressure specified above)

### 3.6.6.3 Measuring Dew Point With or Without a Pressure Sensor

In Scenario 2, the dew point measurement requires both the sensor pressure and the process pressure to be known. Sensor pressure can be entered as a default value, or measured as above, and the process pressure must be entered in the *Process Pressure* field.

**Example** (using standard atmospheric conditions at 25°C):  $P_1 = 500$  psia, and  $P_2 = 14.7$  psia

- As measured by the Panametrics chilled mirror dew point sensor:  $T_{dew_2} = -40^\circ\text{C}$  @  $P_2$ , and  $e_2 = 0.1283$  mbar
- Per Dalton's Law of Partial Pressure:  $e_1 = (P_2/P_1) \times e_2 = (500/14.7) \times 0.1283 = 4.36$  mbar
- Using standard vapor pressure equations, the actual pressurized dew point is calculated by the Optica to be:

$T_{dew_1} = -4.022^\circ\text{C}$

## 3.7 Status Line Indications

The status line at the bottom of the display shows whether the unit is ready for normal operation, is still in its start-up phase or needs service. The following is a complete list of status indications:

**Table 3: Status Indications**

Indication	Meaning
Initializing	The unit is initializing.
Balance	The unit is performing a PACER balance to clear the mirror.
Acquiring	The unit is acquiring stable mirror temperature.
Service	The sensor optics require service, cleaning or adjustment.
Control	The unit is actively controlling the mirror temperature at a stable dew point.
Alarm 1	Alarm 1 has activated.
Alarm 2	Alarm 2 has activated.
Lockout	Heat, Cool, and PACER front panel controls are disabled.
Heat	Sensor Heating is active.
Cool	Sensor Cooling is active.

### 3.7.1 Factory Default Settings

As shipped from the factory, the Optica is normally programmed with the configuration listed in *Table 4* below.

**Table 4: Factory Default Values**

Function	Setting
Analog Output A Analog Output B	Humidity, <i>Units:</i> Tdew °C, <i>Range:</i> -40°C to +60°C Temperature, <i>Units:</i> Tmp °C, <i>Range:</i> 0 to 100°C
Pressure Input 1	<i>Units:</i> psia, <i>Range:</i> 0-30, <i>Default pressure:</i> 14.70, <i>Process pressure:</i> disabled, 14.70
Alarm 1 Alarm 2	Disabled, Humidity, <i>Units:</i> Tdew °C, <i>Set Point:</i> 100.00 Disabled, Temperature, <i>Units:</i> Tmp °C, <i>Set Point:</i> 100.00
Auto Balance	<i>Interval:</i> 720 minutes, Automatic, Disabled, Hold
Data Field 1 Data Field 2 Data Field 3 Data Field 4 Data Field 5 Data Field 6	Humidity, <i>Units:</i> Tdew °C, <i>Range:</i> -40.000 to +60.000°C, <i>Color:</i> green, 1 decimal Humidity, <i>Units:</i> %RH, <i>Range:</i> 0 to 100, <i>Color:</i> blue, 1 decimal Temperature, <i>Units:</i> Tmp °C, <i>Range:</i> 0 to 100, <i>Color:</i> red, 1 decimal Pressure, <i>Units:</i> psia, <i>Range:</i> 0 to 100, <i>Color:</i> yellow, 1 decimal Humidity, <i>Units:</i> ppmv, <i>Range:</i> 0 to 1,000,000, <i>Color:</i> brown, 1 decimal Humidity, <i>Units:</i> ppmw, <i>Range:</i> 0 to 100, <i>Color:</i> violet, 1 decimal
Buzzer	15 msec
General	<i>Data Fields:</i> 3, <i>Lockout:</i> disabled, <i>Offsets and filters:</i> 0
Special	<i>Molecular Weight of Gas:</i> 28.9645
User Equation	None entered
Communication Parameters	<i>Mode:</i> All, <i>Baud rate:</i> 9600, <i>Parity:</i> none, <i>Data bits:</i> 8, <i>Stop bits:</i> 1, <i>Flow control:</i> none
Serial Outputs	<b>Humidity:</b> <i>Units:</i> Tdew °C, <i>Format:</i> DP=##.#, <i>Separator:</i> CR-LF, <i>Terminator:</i> CR-LF, <i>Interval:</i> 1 second, <i>Time Stamp:</i> Enabled, <i>Show Status:</i> Enabled <b>Temperature:</b> <i>Units:</i> Tmp °C, <i>Format:</i> DP=##.#, <i>Separator:</i> CR-LF, <i>Terminator:</i> CR-LF, <i>Interval:</i> 1 second, <i>Time Stamp:</i> Enabled, <i>Show Status:</i> Enabled <b>Pressure:</b> <i>Units:</i> psia, <i>Format:</i> DP=##.#, <i>Separator:</i> CR-LF, <i>Terminator:</i> CR-LF, <i>Interval:</i> 1 second, <i>Time Stamp:</i> Enabled, <i>Show Status:</i> Enabled
Selected Outputs	Humidity, <i>Units:</i> Tdew °C Humidity, <i>Units:</i> % RH Temperature, <i>Units:</i> Tmp °C
Data Log	<i>Status:</i> Disabled, <i>Interval:</i> 1 second, <i>Separator:</i> comma, <i>Terminator:</i> CR-LF, <i>Parameters:</i> humidity, <i>Units:</i> Tdew °C

## 3.8 Sensor Balancing

During normal operation, the sensor mirror surface may become partially obscured with salts or other contaminants from the sample gas. The balance indicator displayed on the screen shows whether the system is operating near the center of its normal range, or has been forced away from the center by mirror contamination. In general, it is recommended to start with an **AUTO** balance cycle provided relatively clean gases are being used. If the Service status indicator is displayed after an **AUTO** cycle, the mirror is likely still dirty and may require use of a **PACER** cycle (described in detail in *"The PACER Cycle" on page 6*). In most applications, it is desirable to perform a balance operation periodically to maintain optimum performance. The interval and type of balance are configurable as described in the Optica programming chapters.

If the Service indicator is displayed after a balance operation, the sensor may need to be adjusted (see *"Minor Maintenance of Sensor Optics" on page 69*).

## 3.9 Helpful Hints For Operating the Unit

**Time response:** At dew points above 0°C, the system stabilizes within a few minutes at a consistent dew layer. The status Control is displayed when the system is stable and readings are valid.

When the system is operating at low frost points (below -40°C), extra care may be required when interpreting readings because of the longer response times of the system. Time response depends on a number of factors including dew/frost point, slew rate, upstream filtering, and flow rate.

- As the dew/frost point becomes lower, water molecules in the air sample become scarcer, and it takes longer to condense a frost layer on the mirror thick enough to establish an equilibrium condition.
- Mirror temperature slew rate depends on dew point and depression (the temperature difference between the mirror and the sensor body); at higher dew points and moderate depressions, it is typically 1.5°C/second. At lower dew points and/or larger depressions, the slew rate is slower.
- Flow rate affects response by determining the rate at which water vapor is supplied or carried off.

There is, of course, a trade-off between response time, control system stability, and sensitivity to contamination.

### 3.9.1 Supercooled Dew Points

Slightly below the freezing point, water can exist in a supercooled liquid state for extended periods of time. Extra care may be needed when making measurements in the frost point region of 0 to -20°C, because the mirror temperature may temporarily stabilize at the supercooled dew point, 0.5 to 1°C below the actual frost point.

To assure that the unit is operating in the ice phase within this temperature range, allow the instrument to operate continuously. Before manually clearing a frost layer, take a reading, and afterwards allow sufficient time to reform a stable frost layer before taking further readings.

### 3.9.2 Contamination

#### 3.9.2.1 Mirror Cleanliness

Proper operation of a condensation hygrometer depends on the condition of the mirror surface. In general, accuracy is reduced when contaminants accumulate on the mirror.

However, the mirror does not have to be microscopically clean. In fact, the mirror performs best a few hours after cleaning, when nucleation sites have formed. On an unscratched, freshly cleaned mirror, there are relatively few nucleation sites on which dew or frost deposits can form, and more time is required to collect a condensation layer at low frost points. Also, overshoot may occur, which can cause oscillations as the temperature stabilizes.

#### 3.9.2.2 Particulate Contaminants

Particulate matter that is insoluble in water may accumulate on the mirror surface, but does not affect the instrument accuracy until the mirror reflectance is reduced substantially. In many cases, particulates improve instrument response by providing condensation sites.

#### 3.9.2.3 Water-Soluble Contaminants

Contaminants which readily dissolve in water, such as naturally occurring salts, are detrimental to accurate vapor concentration measurement by any condensation method. These materials readily go into solution with the water condensate on the mirror surface, and then reduce the vapor pressure in accordance with *Raoult's Law*. As the concentration increases with time, the saturation vapor pressure of the liquid solution decreases.

The unit responds to this lower vapor pressure by elevating the mirror temperature in order to maintain a vapor pressure that is in equilibrium with the partial pressure of atmospheric water vapor. The displayed dew point, therefore, drifts upward above the true dew point. Because the measurement error increases gradually, it often goes undetected.

To determine whether dissolved contaminants are affecting dew point measurement, perform the following steps:

1. Note the indicated dew point.
2. Clean the mirror.
3. Balance the detector by initiating a **PACER** cycle.
4. Measure the dew point again.

If the new reading is lower than the first reading, it is likely that soluble material was present in sufficient quantity to cause a measurement error.

#### 3.9.2.4 Gaseous Contaminants

When a gaseous material that has a higher condensation temperature than that of water is present (even in very low concentrations), the unit will eventually control on that material, rather than on water. The system then displays the condensation temperature of the contaminant, not of water. Such material accumulates on the mirror only when chilled. In the normal atmosphere, gaseous contaminants do not have a detectable effect.

#### 3.9.2.5 Minimizing the Effects of Contaminants

The following steps are suggested for maintaining optimum performance:

- Use the **PACER** feature to reduce the effect of contaminants on the unit's performance (see *"The PACER Cycle" on page 6*).
- Reduce the gas flow rate to reduce the rate of accumulation of contaminants on the mirror.
- Clean the mirror according to the recommended optics cleaning procedure (see *"Cleaning and Balancing the Sensor Mirror" on page 69*). To determine the proper cleaning interval for a given set of conditions, take a dew point reading before and after the cleaning. Any appreciable shift indicates that under these conditions, the mirror should be cleaned more often.

#### 3.9.3 Mirror Flooding

If there is an abrupt transition from dry to moist conditions (particularly when accompanied by a transition from cold to warm temperatures), the mirror may accumulate an overload of moisture. It then may take several minutes before the sensor dries out and valid readings can be obtained. The drying process can be accelerated by heating the sensor.

#### 3.9.4 Sample Line Maintenance

Contaminated sample lines slow the unit's response time and can cause erroneous readings, usually on the high side. Clean the sample lines as often as necessary. To determine the required cleaning frequency, take dew point readings before and after cleaning the lines, sensor cavity, and mirror. If the two readings differ appreciably, the sampling lines should be cleaned more often. To reduce the rate of contamination, reduce flow and/or install a filter upstream.

#### 3.9.5 Pressure Effects

If the pressure of the gas is increased or reduced from atmospheric pressure, but the mixing ratio (moisture content) stays constant, the dew point is correspondingly increased or decreased. The Optica displays the dew/frost point at the pressure to which the sensor chamber is exposed. The sensor location and hookup arrangement can influence the pressure.

When the pressure at the sensor is different from the process pressure, the Optica can perform a conversion from the measured pressure to the desired process pressure (see *"Process Pressure" on page 29* for details).

Alternatively, the dew point change due to pressure change can be calculated by using *Dalton's Law* and the *Smithsonian Tables* or a proper nomograph. *Appendix B. "Humidity Equations and Conversion Chart"* contains basic data for these calculations.

[no content intended for this page]

## Chapter 4. Programming the VGA Optica

### 4.1 Introduction

The Optica is programmed at the factory to display and output the data required for many applications (see *Table 4 on page 33*). In these cases, no further programming is required.

By programming the Optica, the following categories of data can be customized for your application:

the front panel display (up to six parameters displayed numerically and, on the VGA screen, a graphical display)

- Pressure input
- Analog outputs
- Serial output
- Built-in alarms
- Datalogging
- Miscellaneous functions

A built-in help system is included to answer questions you may have while operating the unit. Select the **HELP** button and press **ENTER** to access it.

### 4.2 Programming Fundamentals

Programming is accomplished using two main menu screens and several secondary screens. Each screen displays data fields and control buttons. Use the **TAB** key to step through both the data fields and the control buttons on each screen.

- When a data field is selected, you can change the value of the field as described in *“Data Entry Fields” on page 37*.
- When a control button is selected, pressing **ENTER** performs the button’s function.
  - The **MORE** control button accesses the next programming menu.
  - The **OK** control button returns to the previous menu level.
  - The **HELP** button accesses the unit’s built-in help system.

#### 4.2.1 The Keys

The following keys on the Optica’s front panel are used for programming:

- **ENTER** performs the function shown on a selected control button.
- **TAB** moves cursor to the next field or control button to select it.
- **SHIFT** is an alternate action key. Each press toggles **SHIFT-KEY** mode on or off. When **SHIFT-KEY** mode is on, a green annunciator is displayed in the lower left corner of the screen. **SHIFT-KEY** mode does the following:
  - Accesses the alphabetic characters below the keys on the alphanumeric keyboard.
  - Causes the **TAB** key to move the cursor **backwards** through the fields.
- **Ten alphanumeric keys** are used for entering numbers, letters and math functions.
- **BSP** (Backspace) is used during direct data entry to delete the character to the left of the cursor.
- **Four softkeys** are used as follows:
  - During normal operation, to control the sensor heating and cooling, and balance functions.
  - During programming, to move the cursor on the screen and select specific characters for each key on the alphanumeric keyboard.

#### 4.2.2 Data Entry Fields

There are two types of data entry fields:

- Direct entry
- Drop-down list boxes

### 4.2.2.1 Direct-Entry Fields

Direct-entry fields allow new values to be entered directly from the alphanumeric keyboard. Use the left and right softkeys to move the flashing cursor on the screen to the desired character.

- To enter **numeric** data, just press the appropriate key.
- To enter **alphanumeric** data, first press **SHIFT** to access the letters on the keypad, and then press the appropriate key containing the desired letter. Finally, press the **UP** or **DOWN** arrow softkeys to step through the letters available for that key, both upper and lower case.

**Note:** *It is NOT necessary to press ENTER after setting each value in its field.*

Figure 28 below shows a typical direct-entry field, with the **GrphMin** (Graph Minimum) field selected and ready for numeric input from the keypad.

Units	Tdew °C
GrphMax	60.0000
GrphMin	-40.0000
GrphColor	Green
Decimals	1

Figure 28: Typical Direct-Entry Field

### 4.2.2.2 Drop-Down Boxes

Most programming is done using drop-down boxes that allow the user to select from a list of possible choices for the field.

First, select the field with the **TAB** key. A drop-down list showing the available options opens immediately below the selected field. Be careful not to confuse this drop-down list with other fields below the selected one, which look similar. Use the **UP** and **DOWN** arrow softkeys to select the desired value for the field. When finished, press **TAB** to move to the next field.

Figure 29 below shows a drop-down entry box, with the **GrphColor** (Graph Color) field selected and ready for choosing the desired color using the **UP** and **DOWN** arrow softkeys.

GrphMin	-40.0000
GrphColor	Green
Decimals	1
Buzzer/Sound	15

- Green
- Orange
- Blue
- Violet
- Yellow

Figure 29: Typical Drop-Down Box



### 4.3 Units of Measure

Table 5 below shows the units of measure available for each parameter:

**Table 5: Available Units of Measure**

Parameter	Available Units
Humidity	Tdew °C, Tdew °F, %RH, Twet °C, Twet °F, ppmv, ppmw, Grains/lb, Grains/SCF, g/kg, g/m <sup>3</sup> , lb/mft <sup>3</sup> , kj/kg(0), kj/kg(32), BTU/lb(0), BTU/lb(32), pw (mbar)
Temperature	Tmp °C, Tmp °F, Tmp °K, Tmp °R
Pressure	psia, mbar, bar, Pa, kPa, mmHg, inHg, kg/Cm <sup>2</sup> , Dyne/Cm <sup>2</sup>

### 4.4 User Equations

In some applications an output may be needed that is not a simple function of a single parameter, but a combination of two or three parameters. One or more user equations can be defined within the Optica to calculate new parameters that meet the application requirements. The equation can be formed from following elements:

- The identifiers for the measured or derived parameter units (listed in *Table 6 on page 40*).
- The math operators +, -, ×, /, (,) and ^ (accessed through the math key in **SHIFT** mode)
- The math functions **LOG** and **LN**
- Constants
- Other user equations

The new parameter defined by this equation is given a name and can be displayed or output just like any other parameter.

User *Equations* are entered from Menu 2 (see "*Menu 2*" on page 48). A list of parameters and other elements is displayed. Each element is specified by an identifier such as **A1**. Use these identifiers to form the equation. In addition, another user equation can be used as an equation element by entering its identifier.

Table 6: User Equation Parameters

Identifier	Units	Identifier	Units
Humidity Units:		Temperature Units:	
A0	Tdew °C	A17	Tmp °C
A1	Tdew °F	A18	Tmp °F
A2	%RH	A19	Tmp °K
A3	Twet °C	A20	Tmp °R
A4	Twet °F	Pressure Units:	
A5	ppmv	A21	PSIA
A6	ppmw	A22	mbar
A7	grains/lb	A23	bar
A8	grains/scf	A24	Pa
A9	g/kg	A25	kPa
A10	g/m <sup>3</sup>	A26	mmHg
A11	lb/mft <sup>3</sup>	A27	inHg
A12	kJ/kg(0)	A28	kg/cm <sup>2</sup>
A13	kJ/kg(32)	A29	Dynes/cm <sup>2</sup>
A14	BTU/lb(0)	A31	User Equation 1
A15	BTU/lb(32)	A32	User Equation 2
A16	pw(mbar)	A33	User Equation 3

**Example:** The equation  $2 \times \text{Tdew } ^\circ\text{F} + (\%RH/\text{Twet}^\circ\text{C})$  would be entered as  $2 \times A1 + (A2/A3)$ .

## 4.5 Menu 1

**Menu 1** is shown in *Figure 30* below. This menu is accessed by selecting the **Menu** control button on the main screen and pressing **ENTER**.

The screenshot shows the 'Menu 1' configuration interface. It is organized into several panels:

- Analog Outputs:** Output (A), Parameter (Humidity), Units (Tdew °C), Upper (60.00), Lower (-40.00).
- Pressure Input:** Input (Iin (4-20)), Units (psia), Upper (30.00), Lower (0.00), Default (14.70).
- Process:** Status (Disable), Pressure (14.70).
- Alarms:** Alarm (1), Status (Disabled), Parameter (Humidity), Units (Tdew °C), Type (SetPoint), Upper (100.00), Lower (100.00).
- Automatic Balance:** Interval (min) (720), Type (Auto), Status (Disabled), Track/Hold (Hold).
- Data Fields:** Field (1), Parameter (Humidity), Units (Tdew °C), GrphMax (60.0000), GrphMin (-40.0000), GrphColor (Green), Decimals (1).
- Buzzer/Sound:** (15).

Navigation buttons (up, down, left, right arrows) are on the right side. At the bottom are 'Help', 'More ...', and 'OK' buttons.

Figure 30: Menu 1

**Menu 1** allows programming of the items in the following sub-sections.

### 4.5.1 Analog Outputs

For more information on using the analog outputs, see *"Analog Outputs" on page 15*.

Table 7: Analog Output Options

Item	Function	Available Options
Output	Choose which output channel is being programmed	A and/or B
Parameter	Choose which parameter will be output on the selected channel	Humidity, Temperature, Pressure or User Equation
Units	Choose the units for this parameter	(See <i>Table 5 on page 39</i> for the parameter chosen.)
Upper Limit	Set the parameter value that will produce full-scale output	(Enter a number)
Lower Limit	Set the parameter value that will produce zero output	(Enter a number)

## 4.5.2 Pressure Input

For more information on using these items, see *“Process Pressure” on page 29*.

**Table 8: Pressure Input Options**

Item	Function	Available Options
Input	Choose which pressure input channel is in use, or disable this input.	V in (0-5), I in (4-20), or Use Default
Units	Choose the units for the pressure input.	(See <i>Table 5 on page 39</i> for parameter chosen.)
Upper Limit	Set the pressure that corresponds to full-scale input.	(Enter a number.)
Lower Limit	Set the pressure that corresponds to zero volts or 4 mA input.	(Enter a number.)
Default	Pressure value to be used if the measured input is disabled.	(Enter a number.)
Process	Enter a process pressure when it is different from the pressure at the dew point sensor (see <i>“Process Pressure” on page 29</i> ).	
Status	Set whether the process pressure is active (enabled).	Enable/Disable
Pressure	Enter the process pressure, if this feature is enabled.	(Enter a number.)

## 4.5.3 Alarms

For more information on using the alarms, see *“Alarm Outputs” on page 16*.

**Table 9: Alarm Options**

Item	Function	Available Options
Alarm	Choose which alarm relay is being programmed.	1 and/or 2
Status	Set whether or not the alarm is enabled.	Enabled or Disabled
Parameter*	Set the parameter that can activate this alarm.	Humidity, Temperature, Pressure or User Equation
Units*	Set the units for this parameter.	(See <i>Table 5 on page 39</i> for parameter chosen.)
Type	Set the type of condition that will activate the alarm	SetPoint, Inner Band, Outer Band, Control, Service, PACER
Upper*	The upper side of the alarm band	Enter a number.
Lower*	The lower side of the alarm band	Enter a number.

\* These fields are ignored if the alarm is set to Control, Service, or PACER.

The **Upper** and **Lower** limits set the alarm thresholds as described below for each alarm type (see details in *“Alarm Outputs” on page 16*):

- **SetPoint:** alarm activates when parameter exceeds upper limit, and deactivates when parameter is less than lower limit.
- **Inner Band:** alarm activates when parameter is between upper and lower limits.
- **Outer Band:** alarm activates when parameter is outside upper and lower limits.
- **Control:** alarm activates when Optica is actively controlling mirror temperature.
- **Service:** alarm activates when *Service* indicator is activated.
- **PACER:** alarm activates when **PACER** balance is active.

#### 4.5.4 Automatic Cleaning and Balance Function

**Note:** *For Optica Analyzers with earlier versions of software, see Appendix F. "Automatic Balance (for earlier software versions)".*

Optica Analyzers with version 1.4.1a software have been upgraded to include the ability to program the **PACER** self-cleaning and rebalancing cycle to run once per day at a preset time. This is referred to as a *Clock Time Interval*. When the unit is programmed in this manner, the front panel **PACER** softkey is disabled. The *Elapsed Time Interval* initiates the **PACER** at a preset time after the last **PACER** was run. The automatic balance cycle will always run upon power up of the analyzer.

To program the *Automatic Cleaning & Balance Function* on the Optica VGA monitor:

1. Make sure the internal clock of the Optica has the correct time.
  - a. From the main screen enter **Menu**, then **More**, then **Set Time and Date**.
  - b. Highlight the **Date** and **Time** fields and use the *Keypad* and *Softkeys* to set the correct time.
2. Set the *Time Programmed Balance Cycle*.
  - a. Enter **Menu** and go to the **Automatic Balance Section**.
  - b. Open the **Type** pull down menu and choose one of the four selections (see *Table 10* below).

**Table 10: Automatic Cleaning and Balance Functions**

Item	Function	Type
AUTO	Heats the mirror and balances the optics.	Elapsed Time Interval
PACER	First cools the mirror to develop a thick dew/frost layer, then heats and balances the optics.	Elapsed Time Interval
AUTO-D	Heats the mirror and balances the optics.	Clock Time Interval
PACER-D	First cools the mirror to develop a thick dew/frost layer, then heats and balances the optics.	Clock Time Interval

**Note:** *The **PACER** function will provide more thorough cleaning than the **AUTO** function because it first develops a thick dew/frost layer into which soluble contaminants dissolve. When heated, some of the contaminants are flash-evaporated and the remaining residue accumulates in clusters, resulting in an approximately 85% cleaner surface. The **PACER** cycle generally takes longer to complete.*

3. Manually clean the mirror as required.

**Note:** *Manual cleaning provides the most thorough cleaning.*

4. After manual cleaning, initiate the *Automatic Cleaning & Balancing*.
5. To program a specific time of day at which to initiate the *Automatic Cleaning and Balancing*:

- a. Highlight either **Auto-D** or **Pacer-D**.
- b. In the **Enter Time** dialog box, input the time of day that you would like to initiate the balance cycle in a 24-hour format (e.g., 13:30 would be 1:30 PM).

**Note:** *In this mode the front panel **PACER** initiation function is disabled. Powering down and restarting the unit will have no effect on the time programmed; however, the **PACER** will run on startup as is the normal function.*

6. To program an elapsed time to initialize the *Automatic Cleaning and Balancing*:

- a. Highlight either **Auto** or **Pacer**.
- b. In the **Interval** dialog box, input the elapsed time in minutes (e.g., 720 would enable the balance cycle to run every 12 hours).

**Note:** *If the unit is powered down and restarted, or the Automatic Balance is initiated from the front or by using a LAN, the elapsed time will reset.*

**Note:** **Show Status** should read **Enabled**.

7. Select either **Track** or **Hold** for the analog outputs (4-20 mA/0-5 VDC).

**Note:** *If **Track** is selected, the actual temperature of the mirror will be transmitted. If **Hold** is selected, the last prevailing dew point, measured before the balance cycle was initiated, will be transmitted during the time that the balance cycle is running.*

**IMPORTANT:** For environments or a gas sample where the mirror accumulates contamination rapidly, the use of an inline filter is recommended. Lower flow rates will also reduce the accumulation of contaminants.

#### 4.5.5 Data Fields

**Table 11: Data Field Options**

Item	Function	Available Options
Field	Graph line number and numeric display number to be programmed	1, 2, 3, 4, 5 or 6
Parameter	For the field selected above, choose which parameter will be output.	Humidity, Temperature, Pressure or User Equation
Units	Choose the units for this parameter	See <i>Table 5 on page 39</i> for the parameter chosen.
GrphMax	Set the parameter value that will produce full-scale on the graph.	(enter a number)
GrphMin	Set the parameter value that will produce zero on the graph.	(Enter a number.)
GrphColor	Set the color for the selected graph line.	Black, Red, Green, Orange, Blue, Violet, Yellow or Brown
Decimals	The number of decimal places for the numeric display	Enter a number (6 maximum).

#### 4.5.6 Buzzer/Sound

**Table 12: Buzzer/Sound Option**

Item	Function	Available Options
Buzzer/Sound	Sets the length (apparent loudness) of keyclick sounds.	Enter length of keyclick sound in msec (150 msec maximum).

### 4.5.7 Network Menu

Networking settings including *IP Address*, *Subnet Mask* and *Default Gateway*. Generally, you will obtain these settings from your network administrator. This menu is accessed by selecting the **Network** control button on **Menu 1** and pressing **ENTER**.

The screenshot shows a network configuration menu with the following elements:

- Host Name: Optica
- Domain: (empty)
- Radio buttons:  Get IP from Server,  Specify an IP Address
- IP Address: 192, 168, 0, 7
- Subnet Mask: 255, 255, 255, 0
- Default Gateway: 0, 0, 0, 0
- Buttons: Help, OK

Figure 31: Network Menu

Table 13: Network Settings Options

Item	Function	Available Options
Host Name	Enter the host name for the Optica unit of the LAN.	
Domain	Enter the Domain name for the local network.	
IP Address Type*	Use the left and right arrow keys to select between DHCP and Static IP.	Get the IP from the Server, or Specify an IP Address.
IP Address*	If you choose to specify an IP address, you must enter it here.	Enter four decimal integers between 0 and 255.
Subnet Mask*	If you choose to specify an IP address, you must enter a Subnet Mask.	Enter four decimal integers between 0 and 255.
Default Gateway*	If you choose to specify an IP address, you must enter a Default gateway.	Enter four decimal integers between 0 and 255.
OK button	Save changes and return to the previous screen.	Enter a number (6 maximum).
Help button	Display help for the network screen.	
*You may need to contact your local network administrator for this information.		

### 4.5.8 Datalog

Enter parameters for automatically logging data within the Optica. This menu is accessed by selecting the **Data Log** control button on **Menu 1** and pressing **ENTER**.

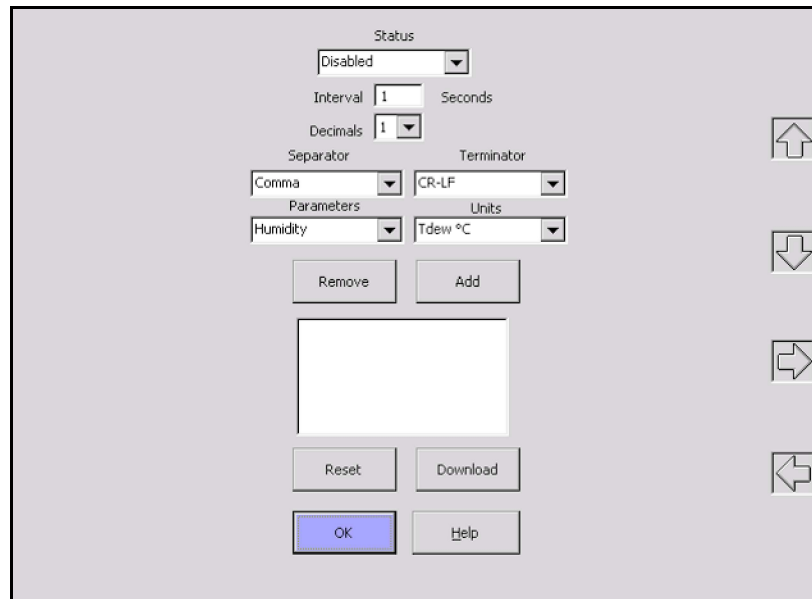

**Figure 32: Datalog Menu**

The large window below the center of the screen shows a list of parameters chosen for logging.

**Table 14: Datalog Options**

Item	Function	Available Options
Status*	Enable or disable datalog.	Enabled/Disabled
Interval*	Enter the logging interval in seconds.	Enter a number.
Decimals	Enter the number of decimal places for logged data.	Enter a number (6 maximum).
Separator*	Choose separator to be used between parameters.	Space, Comma, Tab
Terminator*	Choose the terminator(s) for each group of data.	CR, CR-LF, LF
Parameters	Set the parameter to be programmed (below).	Humidity, Temperature, Pressure, or User Equation
Units	Set the units for the selected parameter.	See <i>Table 5 on page 39</i> .
REMOVE	Control button to remove selected item from the list.	Select button and press <b>ENTER</b> .
ADD	Control button to add the selected unit to the list.	Select button and press <b>ENTER</b> .
RESET	Delete datalog files.	Select button and press <b>ENTER</b> .
DOWNLOAD	Control button to display the logged data on the Download screen (see below).	Select button and press <b>ENTER</b> .

\*Indicated items apply to the entire datalog file.

Use the **UP** and **DOWN** arrow keys to select items in the center window.

Logged data are stored in a file, named with the file's creation time and date. If logging is in progress at midnight, a new file is automatically started at that time. To view or output the logged data, select the **Download** control button and press **ENTER**. The Optica will display the Download screen, described below.



#### 4.5.8.1 Download Screen

The *Download Screen* is accessed by pressing **Download** on the **Datalog** screen. It contains the following elements:

- A list of any saved files containing logged data (upper left)
- An area for displaying logged data (center)
- **View** button: displays the contents of the selected file name
- **OK** button: returns to the previous screen
- **Download** button: sends the selected file to the serial port
- **HELP** button: displays help system
- **Up** arrow button: scrolls the displayed data upwards
- **Down** arrow button: scrolls the displayed data downwards

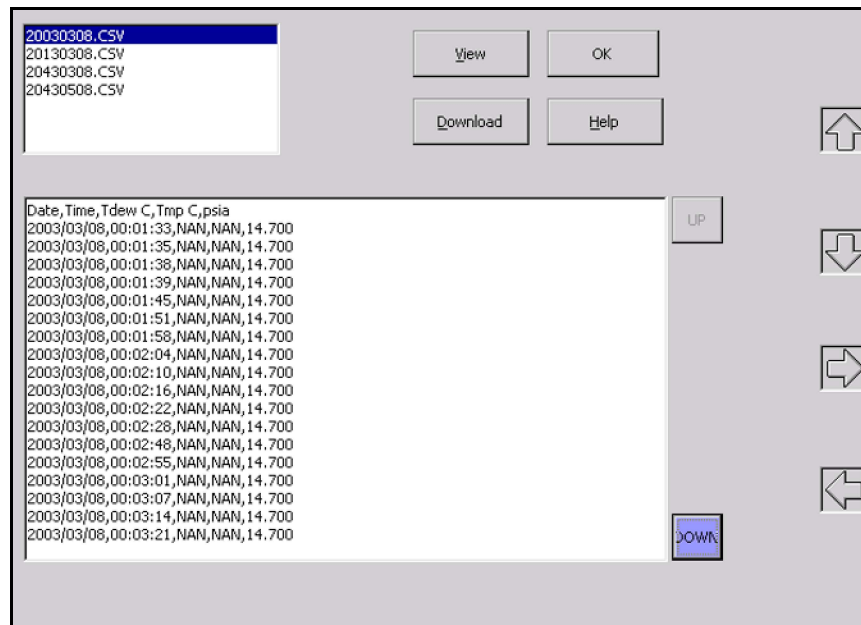

Figure 33: Download Screen

## 4.6 Menu 2

Menu 2 is shown in *Figure 34* below. This menu is accessed by selecting **More** on **Menu 1**, and pressing **ENTER**.

Figure 34: Menu 2

### 4.6.1 General

Table 15: General Options

Item	Function	Available Options
Number of Data Fields	Set the number of parameters to be displayed.	1, 2, 3, 4, 5, 6
Lockout	Set whether or not Heat, Cool, and PACER functions can be activated by the softkeys on the front panel.	Disabled/Enabled
Dew Point Offset	Enter offset value for Dew Point parameter in °C.	Enter value by which the Dew Point parameter will be offset.
Dew Point Filter	Enter filter value for Dew Point parameter.	Enter number of readings to be averaged to create filtered Dew Point.
Temperature Offset	Enter offset value for Temperature parameter in °C.	Enter the value by which the Temperature parameter will be offset.
Temperature Filter	Enter filter value for Temperature parameter.	Enter number of readings to be averaged to create filtered Temperature.
Pressure Offset	Enter offset value for Pressure parameter in psia.	Enter value by which Pressure parameter will be offset.
Pressure Filter	Enter filter value for Pressure parameter.	Enter number of readings to be averaged to create filtered Pressure.

## 4.6.2 Special

Table 16: Special Option

Item	Function	Available Options
Mol. Wt. Gas:	The molecular weight of the gas being analyzed (Default value is molecular weight of dry air: 28.9645)	Enter a number.

## 4.6.3 User Equation

Table 17: User Equation Options

Item	Function	Available Options
Selection	Select which equation to enter or edit.	1, 2, 3
Label:	Enter the test label for the selected equation.	Enter an alphanumeric name.
Equation	Enter the user equation (see <i>"User Equations"</i> on page 39).	Using the keypad, enter the alphanumeric codes for the equation elements, shown in Table 6 on page 40.

## 4.6.4 Communication Parameters

Table 18: Communication Parameter Options

Item	Function	Available Options
Mode	Set the method for sending data.	<b>All</b> (Data is sent continuously.); <b>Query</b> (Data is sent when requested by receiving device.) <i>Query mode is described in "Query Mode Format:" on page 50.</i>
Baud	Set the baud rate as required by the receiving device.	300, 600, 1200, 2400, 4800, 9600, 19200, 38400, 57600
Parity	Set the parity as required by the receiving device.	None, Odd or Even
Data Bits	Set the number of data bits as required by the receiving device.	7 or 8
Stop Bits	Set the number of stop bits as required by the receiving device	1, 1.5 or 2
Flow Control	Set the Flow Control mode as required by the receiving device.	None, X-OFF, RTS/CTS

## 4.6.4.1 Query Mode Format:

Table 19: Query Mode Format

Command:	Returns . . .
\$HELP < >	Help string
\$GETDATA 0 <item> <item> <item>... <item>	Requested data items
\$GETSTATUS 0 < >	Status string
Query mode examples:	
\$GETDATA 0 0 1 < >	returns the Dew Point °C, Dew Point °F
\$GETSTATUS < >	Returns a string of 1s and 0s corresponding to PACER, Service, Control, Heat, Cool, Alarm 1, Alarm 2
<b>Note:</b> <i>The symbol &lt; &gt; indicates a carriage return.</i>	
<b>Note:</b> <i>The 0 and 1 above, following the "GETDATA 0" command, reference the numeric suffix of the parameter identifier from Table 6 on page 40. For example A0 has units Tdew °C, so the 0 requests Tdew °C.</i>	

## 4.6.5 Serial Output Data

Table 20: Serial Output Data Options

Item	Function	Available Options
Selected Outputs	The units of currently selected parameters are shown, along with the number of decimals for each unit.	Units of selected output are displayed. Select one with the UP/DOWN keys to change it or delete it using <b>REMOVE</b> .
Time Stamp*	Output date and time with each data string.	Enabled/Disabled
Show Status*	Output dew point sensor status with each data string (Heat, Cool, Balance, PACER, Service, Alarm 1, Alarm 2).	Enabled/Disabled
Parameter	Select a parameter to configure.	Humidity, Temperature, Pressure or User Equation
Units	Set the units for the selected parameter.	See Table 5 on page 39 for available units.
Format*	Choose output format for the selected parameter.	Dp=##.#, ###.#(Dp), No Label
Separator*	Choose separator to be used between parameters.	Space, Comma, TAB, CR, CR-LF
Terminator*	Choose the terminator(s) for each group of data.	Comma, CR, CR-LF
Interval (sec)*	Enter the output interval in seconds.	Enter a number.
Decimals	Enter the number of decimal places for the selected parameter.	Enter a number (6 maximum).
ADD button	Control button to add the configured parameter to the output list, using the units and number of decimals designated.	Select button and press <b>ENTER</b> .
REMOVE button	Control button to remove from the output list the parameter selected at the top of the serial output menu.	Select button and press <b>ENTER</b>

#### 4.6.6 Set Time & Date

The *Time and Date* menu is accessed by selecting **Set Time and Date** on **Menu 2**, and pressing **ENTER**.

To set the Optica's internal clock, press **TAB** to select each field of the date and time, and press the up and down softkeys to set each field. When the settings are correct, tab to the **OK** button and press **ENTER**.

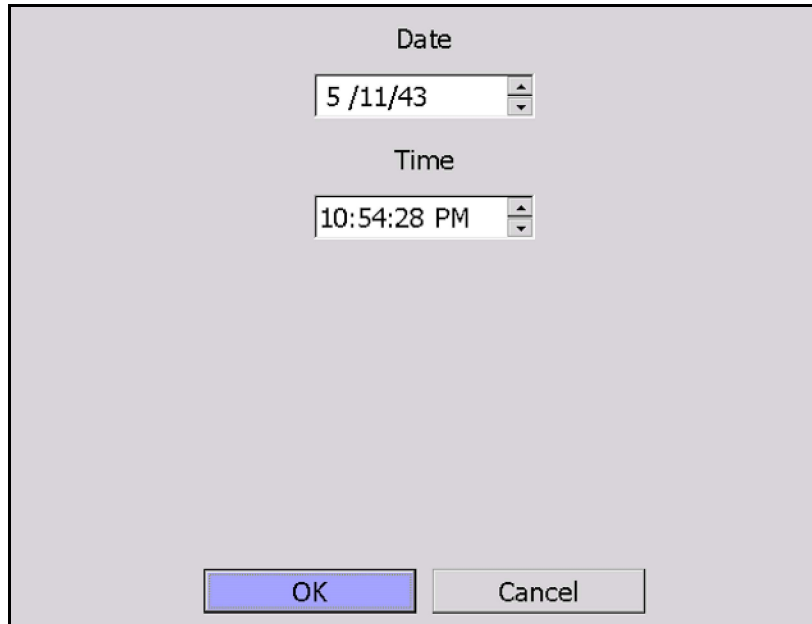

Figure 35: Time and Date

#### 4.6.7 Restore Defaults

To access this choice, select the **Restore Defaults** button on **Menu 2**, and press **ENTER**.

This screen resets all programmable items to the factory defaults shown in *Table 4 on page 33*. Press **TAB** to select **Yes**, and press the **ENTER** key.

## 4.7 Saving Configuration Files

This option allows the user to save a configuration file and then load it onto the system for future use.

**Note:** *To activate the selected configuration, the system must be reset.*

To save the current configuration file:

1. Select **Configuration** on the *Main Screen*. A screen similar to the one shown in *Figure 36* below appears.
2. Type a file name under **Save Configuration File** and click **SAVE**. The name will appear under **Load Configuration File**.
3. To load or delete an existing configuration file, highlight the name under **Load Configuration File** and click **LOAD** or **DELETE** as desired.
4. To exit the *Configuration* screen, click **OK**.

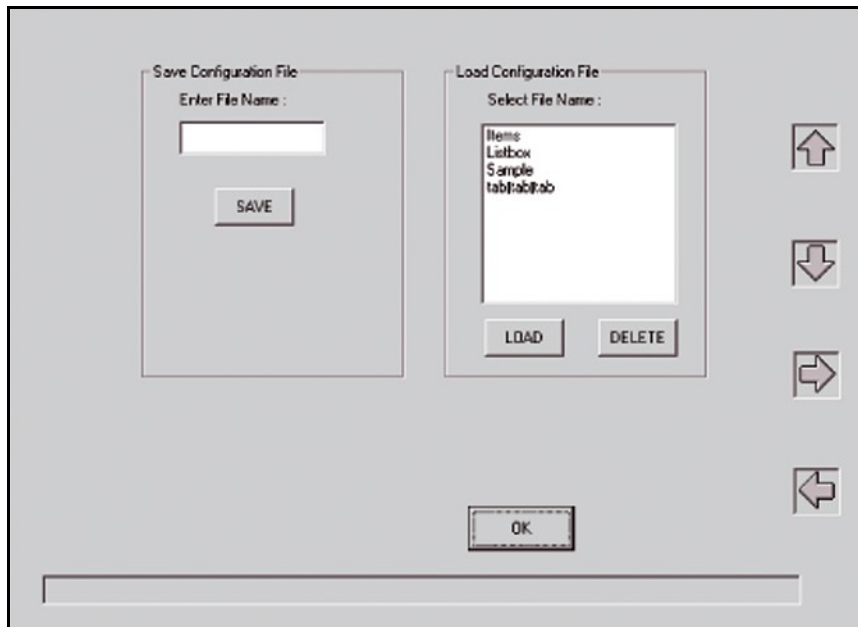

Figure 36: Configuration Screen

## Chapter 5. Programming the 4x40 Optica

### 5.1 Introduction

The 4x40 Optica can be easily programmed to choose the data to be displayed, the data to be output on the analog or serial outputs, and the alarm settings. A typical data display is shown in *Figure 37* below:

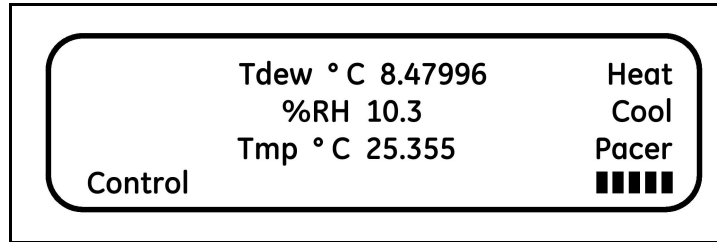

Figure 37: 4x40 Optica Typical Data Display

Table 21 below lists the 4x40 Optica's programmable functions. Each function has a number of settings (discussed in detail in the following sections). Values for some settings are selected from a list of choices; others are entered as numeric or alphanumeric data using the keypad.

Table 21: Programming Functions

Function	Settings
About	Displays software version
Analog Outputs	Parameter choice, units and scaling
Communication Parameters	Baud rate, parity, # data bits, etc.
Serial Output Units	Parameter choice, units/data format
Serial Output Setup	Serial data string format
Alarms	Parameter choice and alarm limits
Data Fields	Parameters & units for displayed data
Pressure Input	Units, scaling and default values
Automatic Balance	Frequency and type of balance
Buzzer and Sounds	Keyclick loudness
General Settings	Offsets, filters, lockout
User Equations	Set user defined calculated values.
Set Time and Date	Enter the current time and date.
Special	Set molecular weight of sample gas.
User Default Settings	Restore default settings.
Factory Calibration	For factory use only.

## 5.2 Programming Technique

The functions of the four softkeys to the right of the display change according to the current state of the unit. These functions, if any, are displayed at the right edge of the screen. While programming, these keys are labelled **UP**, **DOWN**, **LEFT** (displayed as <<<<) and **RIGHT** (displayed as >>>>).

The general method for programming the unit is as follows:

1. To access the programming menus, press the **ENTER/MENU** key.
  2. Press the **DOWN** key to step through the functions that can be programmed (shown in *Table 21 on page 53*).
  3. For a particular function, press the **RIGHT** key to display the first setting for the function. Press the **DOWN** key to step through its available settings.
  4. For a particular setting, press the **RIGHT** key to open the setting for editing.
    - If the setting uses a list of specific choices, the **DOWN** key and/or **UP** key are shown. Press them to step through the choices.
    - If the setting requires a numeric or alphanumeric entry, use the keypad to enter the data:
      - *To enter numeric data, just press the appropriate key.*
      - *To enter alphanumeric data, first press **SHIFT** to access the letters on the keypad, and then press the appropriate key containing the desired letter. Finally, press the up or down arrow softkeys to step through the letters available for that key, both upper and lower case.*
- Note:** *Certain settings have numeric values that are restricted to certain choices. For example, the number of stop bits for serial output may be 1, 1.5, or 2, and may have no other allowable values. This entry is selected from a list of choices, not entered as a numeric value.*
5. After choosing a value for a setting, either press **ENTER** to lock it in or press the **LEFT** key to cancel the entry (restoring the original value) and return to choose another setting.

To return to the function choice, press the **LEFT** arrow key.

A typical programming screen (for setting the *Analog Outputs*) is shown in *Figure 38* below.

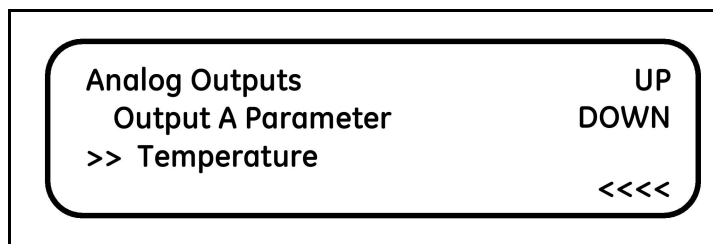
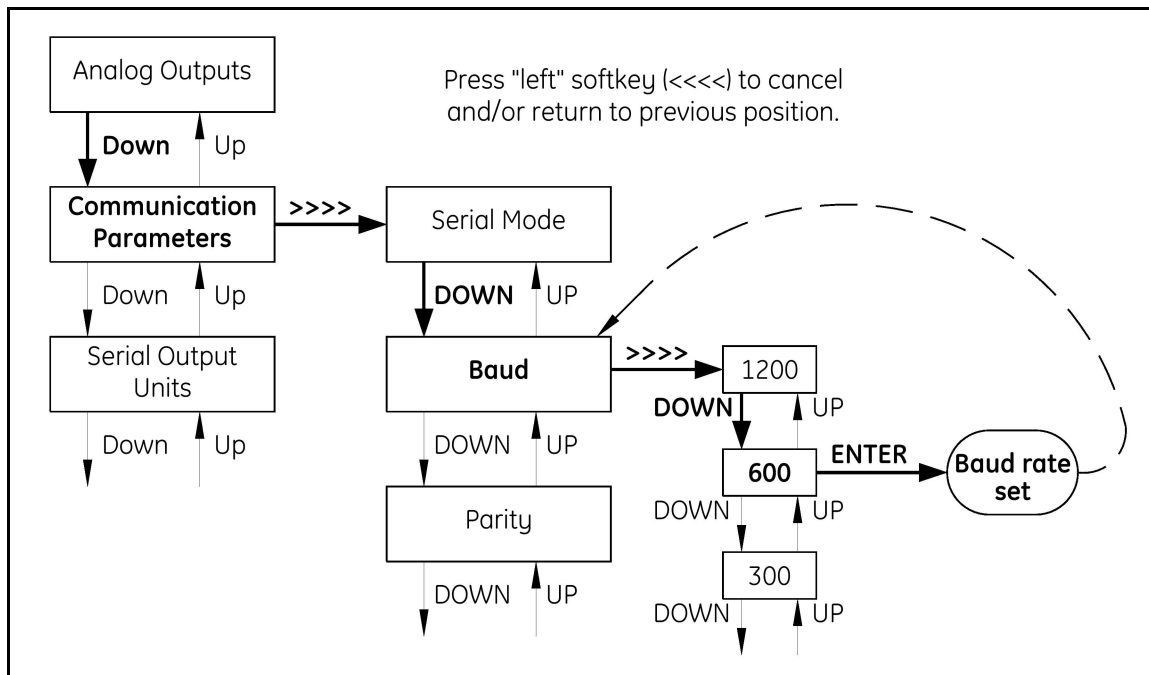

Figure 38: Typical Analog Outputs Programming Screen



An example of programming the *Serial Baud Rate* is shown in *Figure 39* below. Press the **DOWN** and **RIGHT (>>>>)** softkeys as shown to select the parameter to be programmed, choose the value using the **UP** and **DOWN** softkeys, and press **ENTER**.



**Figure 39: Programming the Serial Baud Rate**

## 5.3 Programmable Functions

### 5.3.1 Analog Outputs

**Table 22: Analog Output Options**

Setting	Description	Available Options
Output A Parameter	Choose which parameter will be output on analog channel A.	Humidity, Temperature, Pressure or User Equation
Output A Units	Choose the units for scaling this parameter.	See <i>Table 5 on page 39</i> for the parameter chosen.
Output A Upper	Set the parameter value that will produce full-scale output.	Enter a number.
Output A Lower	Set the parameter value that will produce zero output.	Enter a number.
Output B Parameter	Choose which parameter will be output on analog channel A.	Humidity, Temperature, Pressure or User Equation
Output B Units	Choose the units for scaling this parameter.	See <i>Table 5 on page 39</i> for the parameter chosen.
Output B Upper	Set the parameter value that will produce full-scale output.	Enter a number.
Output B Lower	Set the parameter value that will produce zero output.	Enter a number.

### 5.3.2 Communication Parameters

**Table 23: Communication Parameter Options**

Setting	Description	Available Options
Serial Mode	Set whether data is transmitted continuously or on demand.	All, Query (see <i>"Query Mode Format:" on page 50</i> )
Baud	Set the baud rate to be compatible with the receiving device.	300, 1200, 2400, 4800, 9600, 19200, 38400, 57600
Parity	Set the parity as required by the receiving device.	None, Odd, Even, Mark or Space
Number of Data Bits	Set the number of data bits as required by the receiving device.	7 or 8
Number of Stop Bits	Set the number of stop bits as required by the receiving device.	1, 1.5 or 2
Serial Flow Control	Set the flow control as required by the receiving device.	None, Software, Hardware

### 5.3.3 Serial Output Units

**Table 24: Serial Output Unit Options**

Setting	Description	Available Options
Humidity Units*	Set the units for humidity.	See <i>Table 5 on page 39</i> for the parameter chosen.
Temperature Units*	Set the units for temperature.	See <i>Table 5 on page 39</i> for the parameter chosen.
Pressure Units*	Set the units for pressure.	See <i>Table 5 on page 39</i> for the parameter chosen.
User Units*	Set the selected user equation.	Choose from any available User Equation.
*Note: The <b>TAB</b> key selects or deselects the desired output units. If selected, the number of decimals can be set using a keypad entry (0-6).		

### 5.3.4 Serial Output Setup

**Table 25: Serial Output Setup Options**

Setting	Description	Available Options
Format	Choose the output format for the selected parameter.	For humidity, e.g., Dp=###.#, ###.#(Dp), No Prompt
Field Separator	Choose the separator to be used between parameters.	Space, Comma, Tab, CR, CR-LF
Record Terminator	Choose the terminator(s) for each group of data.	Comma, CR, CR-LF
Interval in seconds	Enter the output interval in seconds (for Serial Mode: All).	Enter a number.
Show Status*	Output dew point sensor status with each data string (Heat, Cool, Balance, PACER, Service, Alarm 1, Alarm2).	Enabled/Disabled
Time Stamp	Output date and time with each data string.	Enabled/Disabled

### 5.3.5 Alarms

For more information on using the alarms, see “Alarm Outputs” on page 16.

**Table 26: Alarm Options**

Setting	Description	Available Options
Alarm #1	Enable or disable Alarm 1.	Enabled/Disabled
Alarm #1 Parameter	Choose the parameter to control Alarm 1.	Humidity, Temperature, Pressure or User Equation
Alarm #1 Units	Set the units for this parameter.	See <i>Table 5 on page 39</i> for the parameter chosen.
Alarm #1 Type	Set the type of condition that will activate Alarm 1.	Set Point, Inner Band, Outer Band, Control, Service, PACER
Alarm #1 Upper	The upper side of the alarm band.	Enter a number.
Alarm #1 Lower	The lower side of the alarm band.	Enter a number.
Alarm #2	Enable or disable Alarm 2.	Enabled/Disabled
Alarm #2 Parameter	Choose the parameter to control Alarm 2.	Humidity, Temperature, Pressure or User Equation
Alarm #2 Units	Set the units for this parameter.	See <i>Table 5 on page 39</i> for the parameter chosen.
Alarm #2 Type	Set the type of condition that will activate Alarm 2.	Set Point, Inner Band, Outer Band, Control, Service, PACER
Alarm #2 Upper	The upper side of the alarm band.	Enter a number.
Alarm #2 Lower	The lower side of the alarm band.	Enter a number.

The **UPPER** and **LOWER** limits set the alarm thresholds. Alarm types are listed below (see details in “Alarm Outputs” on page 16):

- **SetPoint:** Alarm activates when the parameter exceeds the upper limit and deactivates when the parameter is less than the lower limit.
- **Inner Band:** Alarm activates when the parameter is between the upper and lower limits.
- **Outer Band:** Alarm activates when the parameter is outside the upper and lower limits.
- **Control:** Alarm activates when the Optica is actively controlling the mirror temperature.
- **Service:** Alarm activates when the *Service* indicator is activated.
- **PACER:** Alarm activates when the **PACER** balance is active.

### 5.3.6 Data Fields

**Table 27: Data Field Options**

Setting	Description	Available Options
Line 1 Parameter	Choose which parameter will be output on Line 1.	Humidity, Temperature, Pressure or User
Line 1 Units	Set the units for the selected parameter.	See <i>Table 5 on page 39</i> for the parameter chosen.
Line 1 Decimals	Enter the number of decimal places for displayed data.	Enter a number (0-6).
Line 2 Parameter	Choose which parameter will be output on Line 2.	Humidity, Temperature, Pressure or User
Line 2 Units	Set the units for the selected parameter.	See <i>Table 5 on page 39</i> for the parameter chosen.
Line 2 Decimals	Enter the number of decimal places for displayed data.	Enter a number (0-6).
Line 3 Parameter	Choose which parameter will be output on Line 3.	Humidity, Temperature, Pressure or User
Line 3 Units	Set the units for the selected parameter.	See <i>Table 5 on page 39</i> for the parameter chosen.
Line 3 Decimals	Enter the number of decimal places for displayed data.	Enter a number (0-6).

### 5.3.7 Pressure Input

**Table 28: Pressure Input Options**

Setting	Description	Available Options
Analog Input #	Choose which pressure input channel is in use, or disable this input.	4-20 mA, 0-5 volt, User Default
Input Units	Choose the units for pressure units.	See <i>Table 5 on page 39</i> for units.
Input Upper	Set the pressure that corresponds to full-scale input.	Enter a number.
Input Lower	Set the pressure that corresponds to zero volts or 4 mA input.	Enter a number.
Input Default	Pressure value to be used if a measured input is disabled.	Enter a number.
Process Pressure Default	Set whether the process pressure is active (enabled) (see <i>"Process Pressure" on page 29</i> ).	Enabled/Disabled
Process Pressure	Enter the process pressure (if this feature is enabled).	Enabled/Disabled

### 5.3.8 Automatic Cleaning and Balance Function

**Note:** *For Optica Analyzers with earlier versions of software, see Appendix F. "Automatic Balance (for earlier software versions)".*

Optica Analyzers with **Version 1.4.1a** software have been upgraded to include the ability to program the **PACER** self-cleaning and rebalancing cycle to run once per day at a preset time. This is referred to as a *Clock Time Interval*. When the unit is programmed in this manner, the front panel **PACER** softkey is disabled. The *Elapsed Time Interval* initiates the **PACER** at a preset time after the last **PACER** was run. The automatic balance cycle will always run upon power up of the analyzer.

To program the *Automatic Cleaning & Balance Function* on the Optica 4X40 monitor:

1. Make sure the internal clock of the Optica has the correct time. From the main screen:
  - a. Press the **ENTER** key.
  - b. Press the **DOWN** soft key until **Set Time and Date** is displayed.
  - c. Press the **>>>>** soft key.
  - d. Press the **>>>>** soft key.
  - e. Highlight the **Date** and **Time** fields using the tab key. Use the keypad and softkeys to set the correct time.
2. Set the *Time Programmed Balance Cycle*:
  - a. Press the **ENTER** key to access the Main menu.
  - b. Press the **DOWN** soft key until **Auto Balance** is shown.
  - c. Press the **>>>>** soft key.
  - d. Press the **>>>>** to set the interval. Use the soft keys and the key pad.
  - e. Press the **ENTER** key when done.
  - f. Press the **DOWN** soft key to select the pacer type.
  - g. Press the **>>>>** to enter selection mode.
  - h. Press the **DOWN** soft key until the desired pacer type is displayed.
  - i. Press the **ENTER** key to select.
  - j. Press the **DOWN** soft key to enable the **PACER** status.
  - k. Press the **>>>>** soft key to enter selection mode.
  - l. Press the **UP** or **DOWN** soft key until the *enabled* status is displayed.
  - m. Press the **ENTER** key to save the selection.
  - n. Press the **<<<<** key several times to exit the menu.
  - o. Under the **Type** pull down menu there will be four selections (see *Table 29 on page 61*)

Table 29: Automatic Cleaning and Balance Functions

Item	Function	Type
AUTO	Heats the mirror and balances the optics.	Elapsed Time Interval
PACER	First cools the mirror to develop a thick dew/frost layer, then heats and balances the optics.	Elapsed Time Interval
AUTO-D	Heats the mirror and balances the optics.	Clock Time Interval
PACER-D	First cools the mirror to develop a thick dew/frost layer, then heats and balances the optics.	Clock Time Interval

**Note:** *The PACER function will provide more thorough cleaning than the AUTO function because it first develops a thick dew/frost layer into which soluble contaminants dissolve. When heated, some of the contaminants are flash evaporated and the remaining residue accumulates in clusters, resulting in the cleaning of much of the mirror's surface. The PACER cycle generally takes longer to complete.*

3. Manually clean the mirror as required.

**Note:** *Manual cleaning provides the most thorough cleaning.*

4. After manual cleaning, initiate the *Automatic Cleaning & Balancing* cycle. This can be done by powering the analyzer off then on again, if the front panel softkey is disabled.

5. To program a specific time of day at which to initiate the *Automatic Cleaning and Balancing*:

a. Highlight either **Auto-D** or **Pacer-D**.

b. In the **Set Time** section, input the time of day that you would like to initiate the balance cycle in a 24-hour format (e.g., 13:30 will be 1:30 PM).

**Note:** *In this mode the front panel PACER initiation function is disabled. Powering down and restarting the unit will have no effect on the time programmed, but the PACER will run on startup as is the normal function.*

6. To program an elapsed time to initialize the *Automatic Cleaning and Balancing*:

a. Highlight either **AUTO** or **PACER**.

b. In the set time section, input the elapsed time in minutes. (e.g., an elapsed time of 720 minutes would enable the balance cycle to run every 12 hours).

**Note:** *If the unit is powered down and restarted, or the **Automatic Balance** is initiated from the front panel or using a LAN, the elapsed time will reset. **Show Status** should read **Enabled**.*

7. Select either **Track** or **Hold** for the analog outputs (4-20mA/0-5VDC).

**Note:** *If **Track** is selected, the actual temperature of the mirror will be transmitted. If **Hold** is selected, the last prevailing dew point, measured before the balance cycle was initiated, will be transmitted during the time that the balance cycle is running.*

8. Power down and restart the Optica 4x40 display analyzer for the settings to take effect.

**IMPORTANT:** For environments or a gas sample where the mirror accumulates contamination rapidly, the use of an inline filter is recommended. Lower flow rates will also reduce the accumulation of contaminants

### 5.3.9 Buzzer and Sounds

**Table 30: Buzzer and Sounds Option**

Setting	Description	Available Options
Buzzer Timing	Sets the length (apparent loudness) of keyclick sounds.	Enter length of keyclick sound in msec (150 msec maximum).

### 5.3.10 General Settings

**Table 31: General Setting Options**

Setting	Description	Available Options
Dew Point Offset	Enter the offset value for the Dew Point parameter.	Enter the value by which the Dew Point parameter will be offset.
Dew Point Filter	Enter the filter value for the Dew Point parameter.	Enter the number of readings to be averaged to create filtered Dew Point.
Temperature Offset	Enter the offset value for the Temperature parameter.	Enter the value by which the Temperature parameter will be offset.
Temperature Filter	Enter the filter value for the Temperature parameter.	Enter the number of readings to be averaged to create filtered Temp.
Pressure Offset	Enter the offset value for the Pressure parameter.	Enter the value by which the Pressure parameter will be offset.
Pressure Filter	Enter the filter value for the Pressure parameter.	Enter the number of readings to be averaged to create filtered Pressure.
Lockout	Set whether or not the Heat, Cool, and PACER functions can be activated by the softkeys on the front panel.	OFF / ON

### 5.3.11 User Equations

See “User Equations” on page 39 for programming information.

**Table 32: User Equation Options**

Setting	Description	Available Options
Select Equation	Choose an equation to enter or edit.	1, 2, or 3
Edit Label #1*	Enter or edit the label identifying equation 1.	Alphanumeric
Edit Equation #1*	Enter or edit equation 1 using the equation elements shown in <i>Table 6 on page 40</i> .	See <i>Table 6 on page 40</i> .
*The equation number shown is the one chosen in “Select Equation.”		

### 5.3.12 Set Time and Date

**Table 33: Set Time and Date Options**

Setting	Description	Available Options
Set Time	Sets the time.	Enter digits, one at a time, pressing <b>TAB</b> to move to the next digit.
Set Date	Sets the date.	



### 5.3.13 Special

**Table 34: Special Options**

Setting	Description	Available Options
Gas Mole Weight	The molecular weight of the gas being analyzed. (The default value is the molecular weight of air: 28.9645)	Enter a number.

### 5.3.14 User Default Settings

**Table 35: User Default Setting Options**

Setting	Description	Available Options
Restore Defaults	Restore settings to factory defaults shown in <i>Table 4 on page 33</i> .	NO, YES

### 5.3.15 Factory Calibrations

**Table 36: Factory Calibration Options**

Setting	Description	Available Options
For factory use only.		

[no content intended for this page]

## Chapter 6. Network-Based Programming

### 6.1 Introduction

The VGA Optica can also be programmed remotely from a computer over a network, using a browser program such as *Internet Explorer*.

It may be necessary to download and install the **Sun Java Runtime Environment (JRE)**, which may be obtained from either the Panametrics distribution CD or Sun's website. If the Sun **JRE** is not installed on a machine that connects to Optica via Ethernet, a web page will direct the user to Sun's website.

To set up the Optica's networking configuration, see *Chapter 4. "Programming the VGA Optica"* for programming using the Optica's VGA programming method, and follow the instructions listed in *"Network Menu" on page 45*.

### 6.2 Programming Screens

Detailed information on using the Optica Web interface is available via the **Help** buttons. Programming is very similar to programming of the VGA unit described in *Chapter 4. "Programming the VGA Optica"*. Of course, you may also use the mouse to click directly on fields and control buttons instead of selecting items with the **TAB** key.

A typical **Main Data** screen is shown in *Figure 40* below.

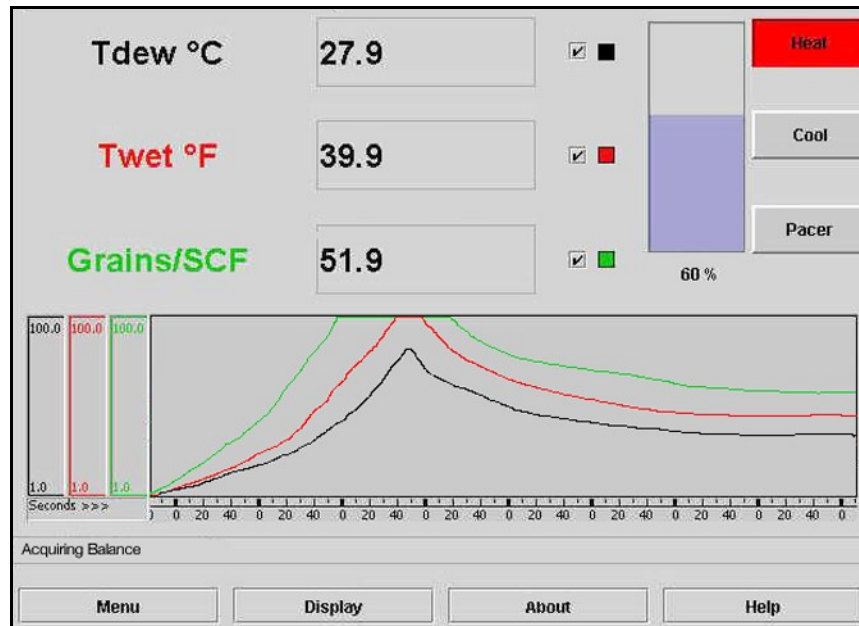

Figure 40: Typical Main Data Screen

Click on **Menu** to display the **Data** programming screen shown in *Figure 41* below.

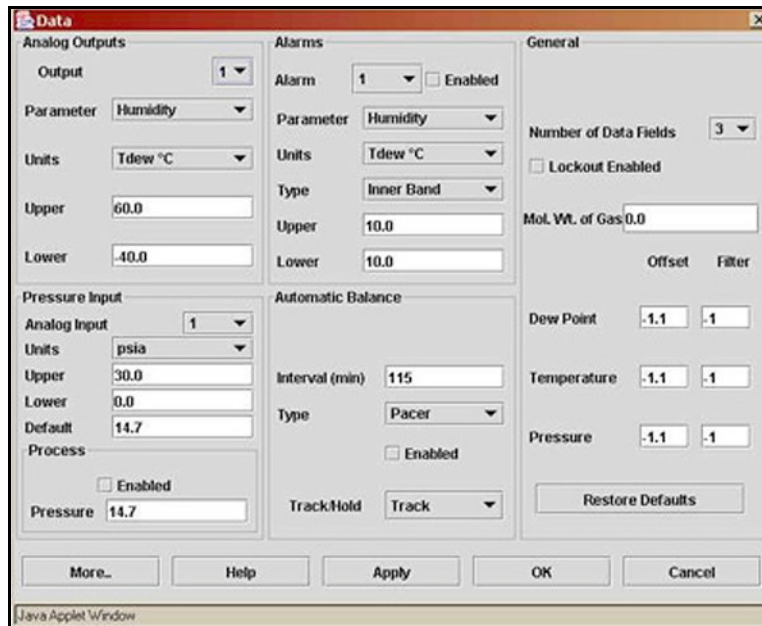

Figure 41: Data Programming Screen

Press **More...** to display the **Other Options** screen shown in *Figure 42* below.

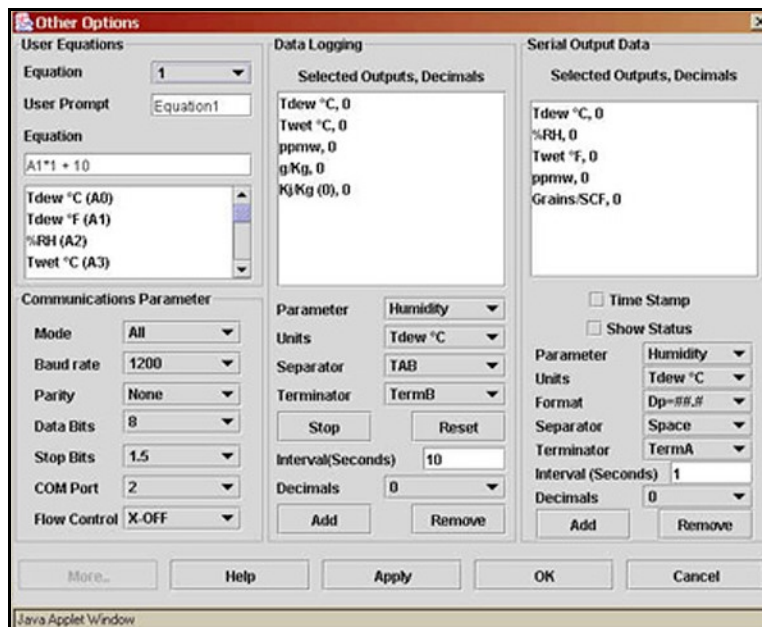
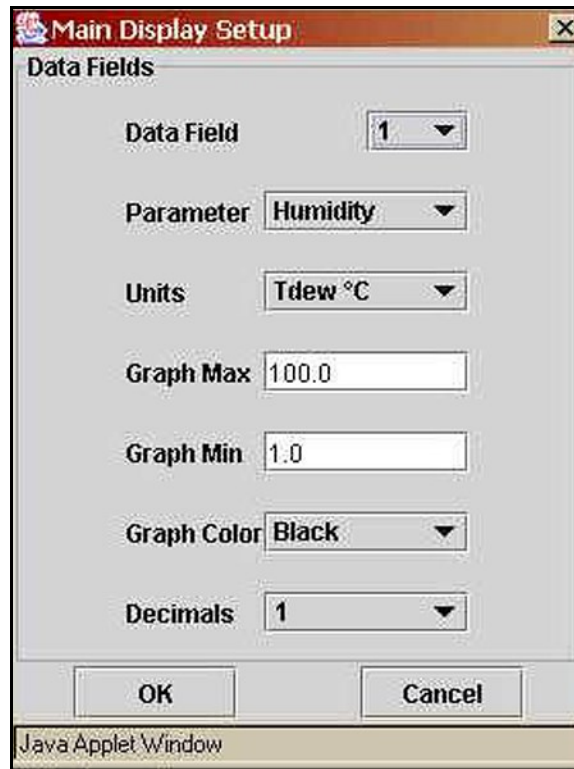

Figure 42: Typical Other Options Screen

Press **Display** from the **Main Data** screen to configure the **Main Display Setup** screen shown in *Figure 43* below.



The screenshot shows a dialog box titled "Main Display Setup" with a close button (X) in the top right corner. The dialog is divided into a "Data Fields" section and a bottom section with "OK" and "Cancel" buttons. The "Data Fields" section contains the following settings:

Field	Value
Data Field	1
Parameter	Humidity
Units	Tdew °C
Graph Max	100.0
Graph Min	1.0
Graph Color	Black
Decimals	1

At the bottom of the dialog, there are two buttons: "OK" and "Cancel". Below the dialog box, the text "Java Applet Window" is visible.

Figure 43: Main Display Setup Screen

[no content intended for this page]

## Chapter 7. Maintenance

### 7.1 Minor Maintenance of Sensor Optics

Periodically inspect and maintain the sensor optics as described in this chapter. These procedures can be performed at any time, but are only necessary when the **Service** indicator appears on the status display, indicating that service is required.

#### 7.1.1 Cleaning and Balancing the Sensor Mirror

Under normal conditions, the system is self-checking and self-balancing. However, there are occasions when particulate matter and water-soluble contaminants reduce sensor mirror reflectance and system accuracy (see *"Contamination" on page 34*). Three features of the Optica system allow users to monitor and adjust the mirror:

- The *balance indicator* (shown in *Figure 44* below) provides a graphic display of how much light is received by the mirror's photodetector. It is also an indicator of the dew layer thickness. This indicator increases and decreases in digital steps.
- The *bias screw* adjusts the light signal received by the reference photodetector and is used as a *"coarse adjustment."*
- The automatic balance, or **PACER** cycle (discussed in *"The PACER Cycle" on page 6*), electronically fine tunes the optical balance between the IR emitters and reference photodetectors.

In operation, the position of the balance indicator will depend on the level of humidity and the sensor used. As the humidity changes, the chilled mirror system will seek to establish control.

As contaminants deposit on the mirror, the optical balance indicator will increase, as will the dew point readings. The **PACER** cycle or manual cleaning and balancing (followed by the **PACER** cycle) will mitigate the contamination.

**Note:** *If the mirror is severely scratch or pitted, you may not be able to balance it. It may be replaced in the field, as discussed in "Field Replacement of Sensor Mirrors" on page 73. For industrial applications, Panametrics recommends the solid platinum mirror.*

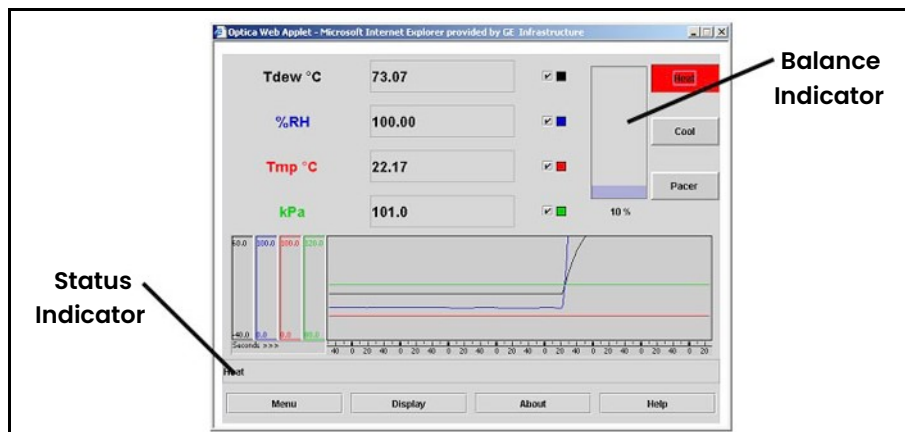

Figure 44: Balance and Status Indicator on Optica Display

## 7.1.2 Procedure for Cleaning and Balancing the Sensor Mirror

When necessary, use the procedure below to clean and balance the sensor mirror. To clean the mirror, you will require the *MSK Kit*, which includes the following essential supplies:

- Cotton swabs
  - Screwdriver or hex driver for some sensors
  - Cleaning solution
1. From the Optica analyzer, press the soft-key next to the **HEAT** button, or, from the *Optica Java* applet running on your PC, move your mouse pointer over the **HEAT** button and click. The button will turn red, as shown in *Figure 44* on page 69.
  2. Allow the dew point temperature (mirror temperature) to attain the maximum value.
  3. To clean the mirror:
    - a. Remove the cap or open the cover of the chilled mirror sensor.
    - b. Put one drop of cleaning solution on a cotton swab.
    - c. Gently rub the cotton swab on the mirror in a circular motion (spiral outwards) to clean the mirror.
    - d. Use a dry swab to dry and buff the mirror. The mirror should be bright and shiny.
    - e. Discard the used swabs.
- IMPORTANT:** If the contamination is severe, then solvents such as alcohol, acetone or hexane may be used, followed by a rinse of the cleaning solution then distilled water. Be sure to dry and buff the mirror with a dry swab.
4. Observe the balance indicator. It should have only one bar segment illuminated. *Figure 45* below shows the possible variations for the indicator while the mirror is heated.

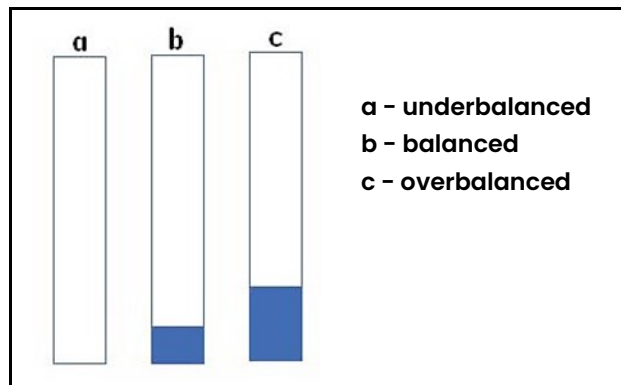
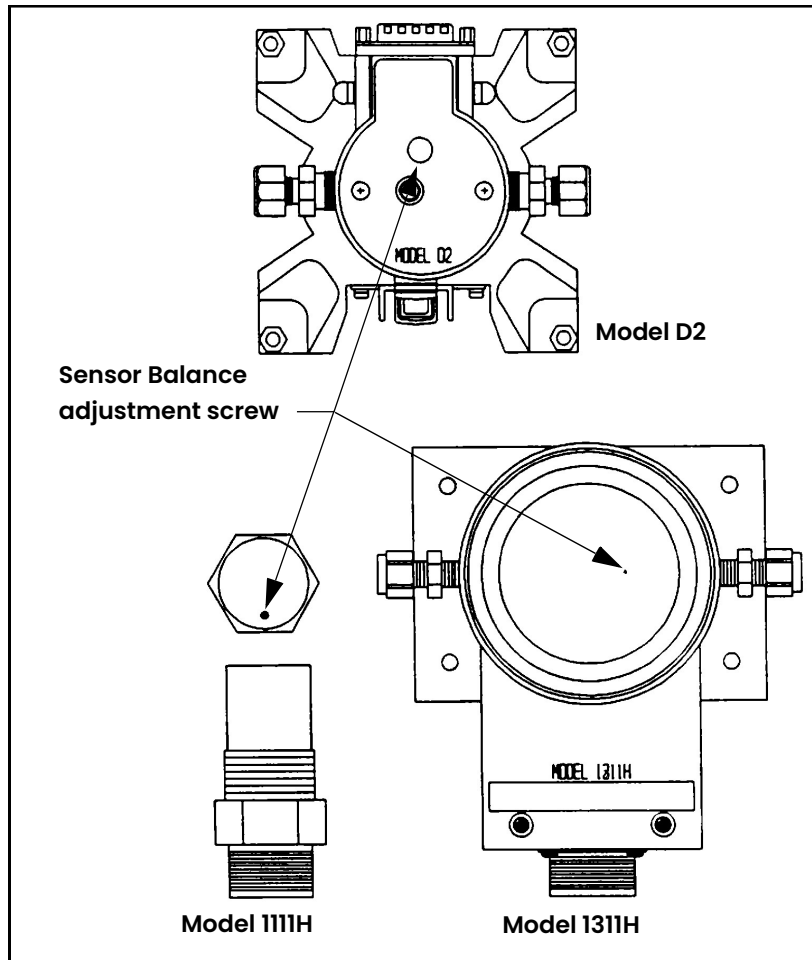

Figure 45: Coarse Adjust Balance Indicator While Mirror is Heated



5. If more than one bar segment or no bars are illuminated, use the screw or hex driver to adjust the optical bias screw (shown in *Figure 46* below) on the sensor until only one bar is illuminated. You are performing a coarse balance adjustment.

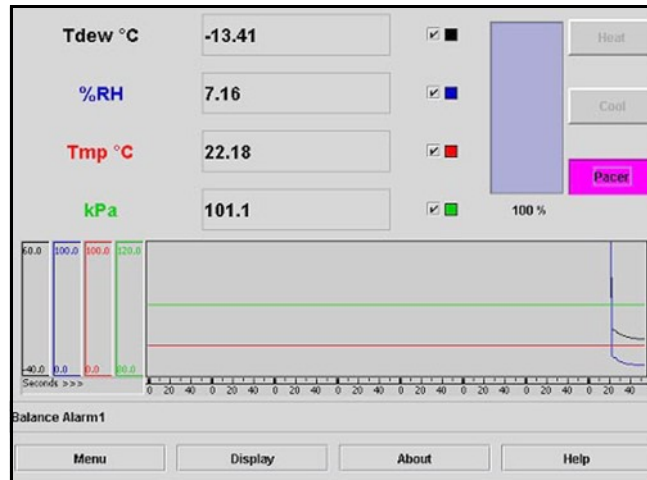

**Figure 46: Balance Adjustment Screw Locations**

**IMPORTANT:** This adjustment is made while the cap or cover is on the 1111H & D2 sensors. For the 1211H, SIM-12H, 1311-DR & 1311-XR, the adjustment is made with the cap removed. In these cases the adjustment should not be made in sunlight, bright incandescent or infrared light. It might be useful to shade the sensor cavity with your hand or place a coin over the sensor cavity.

6. Once balanced, replace the sensor cap and make sure the balance indicator does not change.

7. From the Optica analyzer press the soft-key next to the **PACER** button, or, from *Optica Java* applet running on your PC, move your mouse pointer over the **PACER** button and click. The button will turn magenta, as shown in *Figure 47* below.



**Figure 47: Display with PACER Button Activated**

If the “Automatic Balance” is set for **Pacer**, the system will first cool, then heat. If the unit is set for “Auto,” it will only heat. The system will then automatically fine tune the optical balance. The word **Balance** will appear in the lower left of the display, followed by the phrase **Balance\_acquiring**.

The unit will then cool to the dew point and the balance indicator will increase when dew or frost condenses on the mirror. The dew point reading might overshoot, then it will stabilize (assuming the sensor is exposed to constant humidity). *Figure 48* below shows the possible stages of the balance indicator.

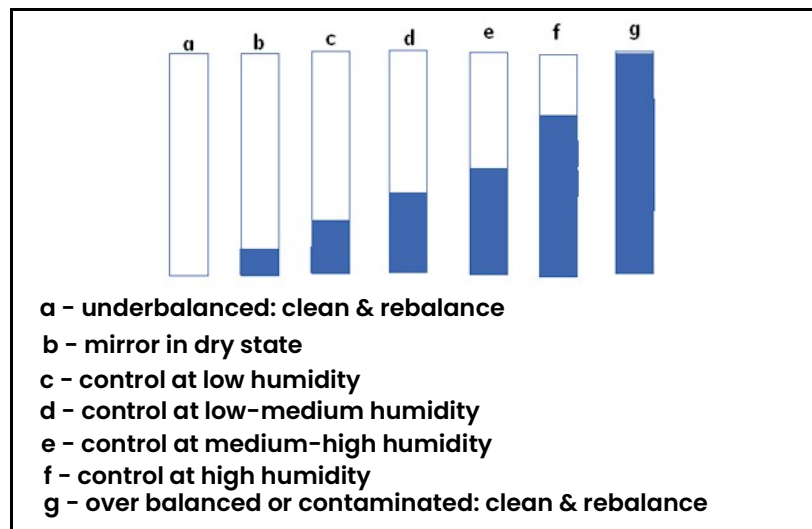

**Figure 48: Stages of Balance Indicator**

When a stable dew or frost layer is attained, you will see the word **Control** in the lower left. The Optica is now reading the correct dew/frost point and a stable dew or frost layer has been established. When the Optica is exposed to typical room humidity, this process takes 5-6 minutes. For very dry conditions, the unit may not display **Control** for several hours. However, the **PACER** indicator will go out. The sensor must first accumulate a dew or frost layer on the mirror before it can display **Control**.

8. If you see the word **Service** displayed in the lower left, repeat steps 1-7.

## 7.2 Field Replacement of Sensor Mirrors

One advantage of using a Panametrics chilled mirror dew point sensor is that the mirror is user-replaceable. The sensor does not have to be returned to the factory for replacement of the reflective surface, unless that is desired.

A mirror may require replacement for any of the following reasons:

- The mirror is constructed of silver/rhodium plated copper. Copper provides excellent thermal conductivity to the platinum thermometer. However, some gas constituents, such as sulfur dioxide (SO<sub>2</sub>) may react with the copper and eventually pit the surface or form a copper sulfate coating.
- The reflective surface may be gradually abraded by sharp dirt particles in the gas being measured.
- The mirror surface may be accidentally scratched or gouged during use or cleaning.

If the sensor mirror has reacted with a corrosive material in the gas sample, such as an acid or sulfur compound, it should be replaced with a solid platinum mirror to remove any possibility of copper corrosion.

In extreme cases, a solid platinum mirror can make possible a successful application of chilled mirror technology. For example, measurements in tobacco factories and malting houses have drastically improved after this change, since both locations have sample gas constituents that attack copper.

### 7.2.1 Replacing the Sensor Mirror

**Required equipment:** torque driver, set to 20–30 inch-ounces of torque. Panametrics type **TW-1** is recommended.

The kit supplied by Panametrics contains the replacement mirror, a container of white thermal compound for proper heat transfer, and (in some models) a mylar washer that is to be placed under the mirror. To install the replacement mirror, complete the following steps:

1. Deactivate the sensor cooler, using one of the following actions:
  - Turn the sensor power off
  - Place the sensor switch to heat
  - Disconnect the sensor cable
2. Turn off the sample gas. Make sure the sensor cavity is depressurized before continuing with the next step.
3. Open the sensor by removing the sensor cover.
4. Unscrew and discard the old mirror, using a 3/16-inch (0.187) hex socket.
5. Use a toothpick or similar tool to place a small amount of thermal compound in the hole supporting the mirror.



#### **CAUTION!**

**Do not apply thermal compound to the mirror stem.  
Do not use an amount large enough to leak out when the mirror is tightened.  
Do not allow any compound to get on the mirror surface, as it is very difficult to remove completely.**

6. Carefully screw in the new mirror and tighten to the proper torque as specified for the particular sensor.
7. Carefully clean the mirror surface, using a cotton swab and the Panametrics cleaning solution supplied with the maintenance kit. Distilled alcohol or diluted alcohol is also acceptable.
8. Replace the cover and return the sensor to normal operation. Under some circumstances, a new mirror may operate in a somewhat unstable manner for the first hour or two.

## 7.3 Test and Calibration

The procedures in this section effectively test and/or calibrate the following aspects of the Optica:

- Startup and power supply voltage
- Normal sensor operation
- Front panel display
- Digital and analog outputs.

The unit has been completely tested and calibrated at the factory, and is ready to plug in and operate. As shipped, it meets all of our published specifications.

When ordered as a complete hygrometer system with a chilled mirror sensor and cable, it is verified at a number of points against a dew point system that has been certified by the U.S. *National Institute of Standards and Technology (NIST)*. A *Certificate of Compliance* is supplied with the unit to indicate traceability.

## 7.4 Troubleshooting

### 7.4.1 The Display Doesn't Light Up

1. Check the **POWER** switch on the rear panel. Make sure it is **ON**.
2. Check the line cord. Make sure both ends are plugged in and that it is plugged into a proper source of AC voltage.
3. Check the power supply. Make sure it is connected and has the proper output voltage.
4. Check the fuse. Make sure the proper fuse size is installed. Make sure the fuse is not open.

### 7.4.2 "Service" Appears on the STATUS Display Line

The text **Service** displayed on the **STATUS** line means service is required. The most frequent problem requiring service is that the mirror surface is contaminated and should be cleaned.

Clean and balance the sensor mirror (refer to *"Cleaning and Balancing the Sensor Mirror" on page 69*). Next, run the instrument through a **PACER** cycle. If, at the end of the cycle, the **Service** status appears again, repeat the cleaning and balancing procedure, or contact Panametrics.

### 7.4.3 Incorrect Dew Point Display

If the dew/frost point reads incorrectly, first check the standard preventive maintenance items:

- Clean and balance the sensor mirror (refer to *"Cleaning and Balancing the Sensor Mirror"* on page 69).

An alternative method for checking the accuracy of the unit's electronics is to use a precision resistance decade box in place of the platinum thermometer. Wire the decade box to the unit's sensor connector as shown in *Figure 49* below, and verify that the resistance settings shown in the table produce the temperatures shown.

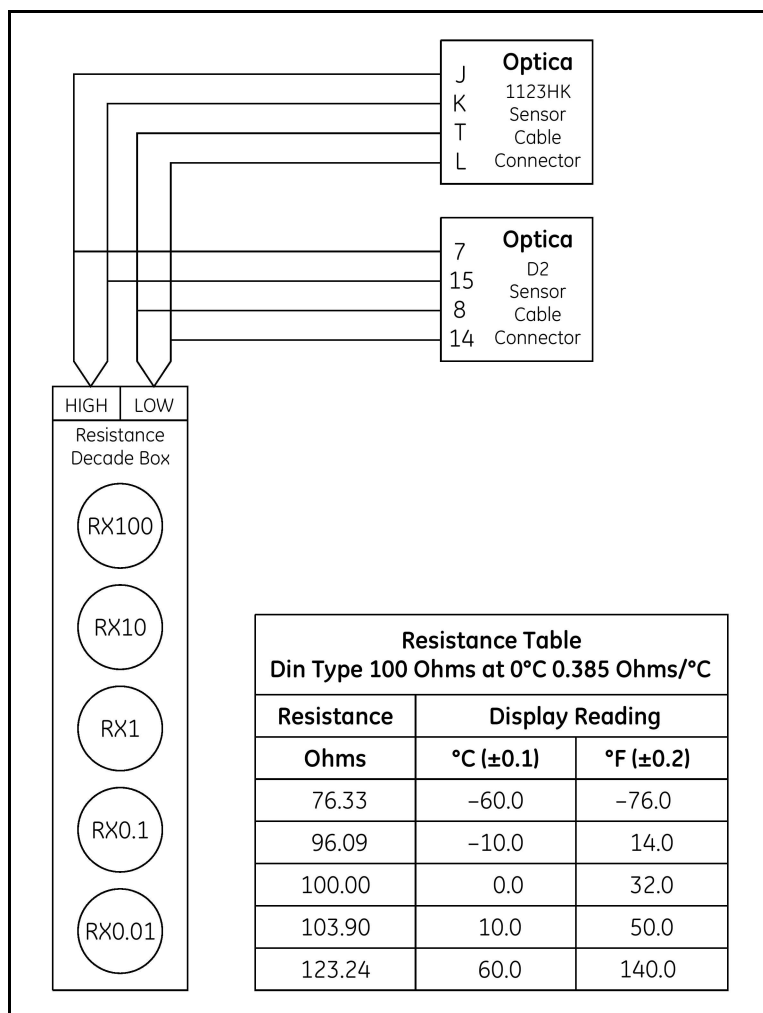

**Figure 49: Using a Resistance Decade Box**

#### 7.4.4 “Balance” Remains on the Status Line

When the word **Balance** remains displayed on the front panel for more than 15 minutes, the instrument has not recovered from a **PACER** cycle.

- Check that the sensor and sensor cable are connected. If necessary, connect them, and the unit will complete the **PACER** cycle after a short time (5 to 15 minutes).
- The sensor optical bridge may be out of balance. Refer to *“Cleaning and Balancing the Sensor Mirror”* on page 69 for instructions.

#### 7.4.5 No Analog Output

If there is no analog output, but the digital display indicates correctly, check the analog output scaling. For the **VGA** unit, see *“Analog Outputs”* on page 41. For the 4x40 unit, see *Function 1* in *“Analog Outputs”* on page 56.

#### 7.4.6 No Serial Output

Check the serial port programming for proper settings. For the **VGA** unit, see the instructions in *“Serial Output Data”* on page 50. For the **4x40** unit, see the instructions in *“Serial Output Setup”* on page 57.

## Appendix A. Specifications

### A.1 Performance

#### A.1.1 Accuracy [complete system at 25°C (77°F)]

##### A.1.1a Dew/Frost Point:

±0.2°C (±0.36°F)

##### A.1.1b Temperature (optional):

±0.15°C (±0.27°F)

##### A.1.1c Pressure (optional):

±0.5% of full scale

##### A.1.1e Relative Humidity (optional):

Governed by accuracy of dew point and temperature sensors

##### A.1.1f Other Humidity Parameters: (optional)

Governed by accuracy of dew point, temperature and pressure sensors

##### A.1.1g Sensitivity

> 0.05°C (0.09°F)

##### A.1.1h Repeatability

± 0.05°C (±0.09°F)

##### A.1.1i Hysteresis

Negligible

### A.1.2 Measurement Ranges

#### A.1.2a Chilled Mirror Sensors: (available)

1111H, 1211H, D-2, SIM-12H, 1311DR, 1311XR

##### A.1.2b Range:

-80°C to +85°C (-112°F to +185°F)  
dew/frost point, depending on sensor used

#### A.1.2c Temperature Sensor: (optional)

T-100E: -100°C to +100°C (-148°F to +212°F)

#### A.1.2d Pressure Sensors (optional):

PT-30A: 0 – 30 psia (0 to 2 bar)  
PT-300A: 0 to 300 psia (0 to 21 bar)  
User supplied 4-20mA or 0-5 volt signal

#### A.1.2e Recommended Sample Flow

0.5 to 5.0 SCFH (0.25 to 2.5 L/min)

### A.1.3 Response Time

#### A.1.3a Dew/Frost Point Cooling Rate:

1.5°C (2.7° F)/sec [typical, above 0°C (32°F)]

### **A.1.3b Temperature Response: (optional)**

< 7 sec for step change within +25°C to +70°C (+77°F to +158°F)

### **A.1.3c Pressure Response (optional):**

1 sec to 90% of steady state (10% to 90% change)

### **A.1.3d Update Time**

1 sec

## **A.2 Functionality**

### **A.2.1 Analog Outputs**

4–20mA DC, 500 Ohm maximum load, 0–5 VDC, 5mA maximum

### **A.2.2 Digital Output**

Serial port

### **A.2.3 Alarms**

#### **A.2.3a Relay (optional):**

Form C (SPDT) 2A, 240 VAC or 30 VDC (resistive load)

### **A.2.4 Displays**

640 X 480 pixel color LCD or 4-line X 40-char LCD

### **A.2.5 Power**

100 to 120 VAC or 200 to 240 VAC ( $\pm 10\%$ ), 50–60 Hz, 200 W

### **A.2.6 Operating Ranges**

#### **A.2.6a Dew Point Sensors**

##### **Ambient Temperature:**

–15°C to +80°C (+5°F to +176°F), depending on sensor

##### **Pressure:**

0 to 300 psig (0 to 22 bar), depending on sensor)

#### **A.2.6b Electronics**

##### **Ambient Temperature:**

0°C to +50°C (+32°F to +122°F)

##### **Relative Humidity:**

85% maximum



## A.3 Physical (Bench Mount)

### A.3.1 Dimensions

13.5"W x 7.25"H x 13.5"D (343 x 184 x 343 mm)

### A.3.2 Weight

12.75 lb (5.78 kg)

### A.3.3 Shipping Weight

17.75 lb (8 kg)

### A.3.4 Environmental

General purpose bench-, panel-, or rack-mount

## A.4 Physical (Wall Mount)

### A.4.1 Dimensions

13.70"W x 16.725"H x 6.5"D (348 x 425 x 165 mm)

### A.4.2 Weight

15.5 lb (7 kg)

### A.4.3 Shipping Weight

22.5 lb (10.2 kg)

### A.4.4 Environmental

Surface-mount, industrial environment (Type 4)

## A.5 Optional Accessories

19" rack mount adapter

### A.5.1 T-100E

Temperature sensor

### A.5.2 PT-30A

Pressure transducer (0 – 30 psia)

### A.5.3 PT-300A

Pressure transducer (0 – 300 psia)

## A.6 European Compliance

Complies with EMC Directive 2004/108/EC and 2006/95/EC Low Voltage Directive (Installation Category II, Pollution Degree II)

**Note:** *Product has reduced limits for Radiated immunity between 88 and 108 MHz and conducted immunity between 11 and 32 MHz.*

[Specifications subject to change without notice]

[no content intended for this page]

## Appendix B. Humidity Equations and Conversion Chart

### B.1 Introduction

The following symbols appear in the equations below:

$e$  = Vapor Pressure, millibars

$e_i$  = Vapor Pressure with respect to ice, millibars

$e_w$  = Vapor Pressure with respect to water, millibars

$e_{is}$  = Saturation vapor pressure, ice, millibars

$e_{ws}$  = Saturation vapor pressure, water, millibars

$P$  = Total Pressure, millibars

$T$  = Temperature, °C

$T_a$  = Ambient temperature, °C

$T_d$  = Dew point temperature, °C

$T_f$  = Frost point temperature, °C

### B.2 Vapor Pressure

Saturation vapor pressure with respect to water is a function of temperature only and is given by the following:

$$E_{WS} = 6.1121 \text{EXP} \left[ \frac{17.502T}{240.97 + T} \right]$$

Saturation vapor pressure with respect to ice requires a minor adjustment of the constants as given by the following:

$$E_{IS} = 6.1115 \text{EXP} \left[ \frac{22.452T}{272.55 + T} \right]$$

In addition to yielding saturation vapor pressure as a function of ambient temperature, the above equations also yield ambient vapor pressure as a function of dew/frost point.

The total pressure of a gas mixture is equal to the sum of the partial pressure each gas would exert, were it to occupy the same total volume, according to Dalton's law.

### B.3 Humidity

*Relative Humidity* is defined as the ratio of the water vapor pressure ( $e$ ) to the saturation vapor pressure ( $e_s$ ) at the prevailing ambient or dry bulb temperature ( $T_a$ ):

$$\%RH = 100\left(\frac{E}{E_S}\right) = 100\left[\frac{E_W(T_D)}{E_{WS}(T_A)}\right]$$

Absolute humidity is expressed as water vapor density: water vapor mass per unit volume of dry air, according to the following:

$$\frac{G}{M^3} = \frac{216.7E(T_D)}{T + 273.16}$$

Water vapor content expressed as parts per million by volume is given by the following:

$$PPM_V = 10^6 \frac{E(T_D)}{P - E(T_D)}$$

Expressing water vapor content as parts per million by weight (or mixing ratio) requires multiplication of the above by the ratio of the molecular weight of water to that of air as given by the following:

$$PPM_W = (0.622 \times 10^6) \frac{E}{P - E}$$

See *Figure 50 on page 83* for a graphical humidity conversion chart.

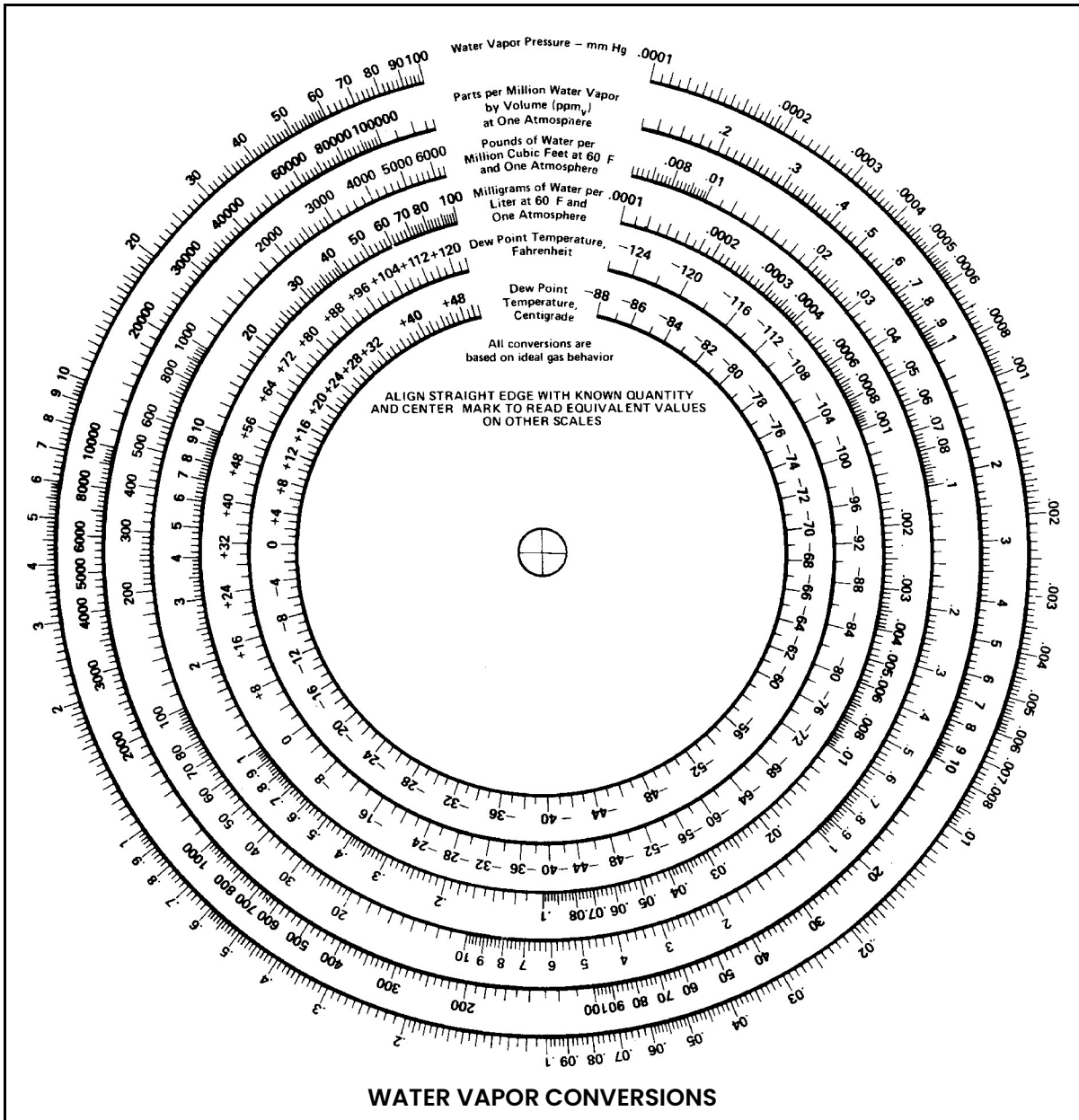

Figure 50: Graphical Humidity Conversion Chart

[no content intended for this page]

## Appendix C. Configuring the Serial Interface

### C.1 Wiring to a Personal Computer

The Optica is configured as *Data Terminal Equipment (DTE)*. The following pins are used on the Serial interface:

- Pin 2 – Transmitted data (**TXD**)
- Pin 3 – Received data (**RXD**)
- Pin 5 – Signal ground (**GND**)

To send the output of the Optica to a personal computer, use the cable arrangement shown in *Figure 51* below.

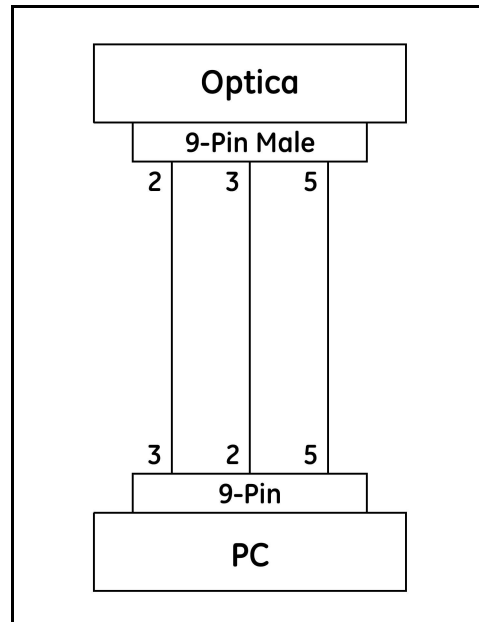

Figure 51: Wiring Diagram – Optica to Personal Computer

[no content intended for this page]



## Appendix D. Chilled Mirror Sensors

### D.1 Introduction

Panametrics offers a choice of six, fully interchangeable, chilled mirror sensors which differ primarily in their depression (cooling) capability. Depression capacity determines the minimum dew point that can be measured. All of the sensors feature low-noise, infrared optics, a field-replaceable mirror, and can be located up to 300 ft (91 m) from the electronics. Other advanced features, depending on the sensor selected, include heating capability, four- or five-stage thermoelectric cooling, air and water cooling for additional depression, and modular, field-replaceable optics and cooling assemblies.

Many of these features were pioneered by Panametrics, and are available only on Panametrics products.

A chilled mirror sensor is generally selected so that its depression capability will allow it to measure the lowest dew/frost point anticipated for the application.

### D.2 Depression

A Peltier device is a solid-state heat pump. It has one surface thermally bonded to the body (base) of a dew point sensor and the other surface bonded to the mirror block. When current is supplied to the Peltier device, heat is "pumped" from the mirror block to the sensor body where it is dissipated. With full cooling current, the mirror block will eventually cool to its minimum temperature. The difference between the temperatures of the mirror block and the sensor body when the mirror block is at this minimum temperature is defined as the depression capability of the sensor.

Depression capability is a function of how many "stages" the Peltier device has stacked in series. Thus, a two-stage sensor typically has 60°C to 65°C (108°F to 117°F) of depression capability, and can measure lower dew/frost points than a one-stage sensor which has 45°C (81°F) of depression capability. Depression is normally specified at 25°C (77°F) ambient temperature. For liquid-cooled sensors, it is specified at the coolant temperature. As ambient temperature (and, therefore, sensor body temperature) is decreased, depression capability also decreases, due to the drop-off in efficiency of the thermoelectric cooler.

Therefore, there are limitations to using liquid-cooled sensors to increase low-end measurement range. At nominal dew/frost points, approximately one third of the additional cooling is lost due to cooler inefficiency, and does not result in additional measurement range. At low dew/frost points, as much as one half may be lost. As ambient temperature is increased, depression capability increases, resulting in a wider measurement range.

### D.3 Measurement Range

The measurement range of a chilled mirror sensor is defined as the temperature range over which a stable dew or frost layer can be maintained on the mirror. Note that in order to acquire a dew or frost layer on the mirror, the depression capability of a sensor must extend below its measurement range. The minimum required differential between depression range and measurement range is 5°C (9°F) at nominal dew/frost points, and increases to 10°C to 12°C (18°F to 22°F) at very low frost points.

Measurement range is normally specified at 25°C (77°F) ambient temperature in air at atmospheric pressure. For sensor body temperatures other than 25°C (77°F), measurement range can be estimated by first estimating depression capability, and then decreasing this range according to the minimum required differential. For most gases other than air, the effect on measurement range is negligible. However, gases such as hydrogen or helium, which are more thermally conductive than air, will result in a decrease of several degrees in the measurement range. Measurement range will decrease as gas pressure is increased, because the increased density (and, therefore, increased thermal conductivity) of the gas results in an increased heat load. For air or nitrogen, each 50 psi (3 bar) increase above atmospheric pressure will result in a loss of approximately 2°C (4°F) of depression capability. Conversely, operating under vacuum may result in a small increase.

Other factors influencing sensor selection include temperature and pressure ratings, and whether anticipated dew points will be higher than ambient temperature.

## D.4 Comparing Optica Sensor Models

See *Table 37* below for a comparison of the various Optica chilled mirror sensors.

**Table 37: Chilled Mirror Sensor Comparison Chart**

Parameter	Model 1111H	Model D-2	Model 1211H	Model SIM-12H	Model 1311DR	Model 1311XR
<b>System Performance</b>						
Standard Accuracy*	0.2°C	0.2°C	0.2°C	0.2°C	0.2°C	0.15°C
Optical Accuracy*	0.15°C	0.15°C	0.15°C	0.15°C	0.15°C	
Cooling Stages	1	2	2	2	4	5
Depression (at 25°C (77°F), 1 atm, in air)	45°C	65°C	65°C	65°C	air: 95°C w/15°C coolant: 105°C	112°C with 15°C coolant
Typical Measurement Range (at given ambient, 1 atm)	@25°C ambient	@ 25°C ambient	@ 25°C ambient	@ 85°C ambient	@ 25°C ambient	@ 25°C ambient
Dew/Frost Point	-15° to +25°C	-35° to +25°C	-35° to +25°C	-10° to +85°C	air: -60° to +25°C, liquid: -70°C to +25°C	-80° to +25°C
RH (equivalent)	6% to 100%	1.5% to 100%	1.5% to 100%	1% to 100%	air: 0.03% to 100%, liquid: 0.007% to 100%	0.0003% to 100%
<b>Functional Characteristics</b>						
Power	From Optica	From Optica	From Optica	115/230VAC 75 watts	115/230VAC 300 watts	115/230VAC 700 watts
Ambient Temperature Range	-15° to +80°C	-25° to +85°C	-15° to +100°C	-15° to +50°C	0° to +35°C	0° to +35°C
Pressure Range (psig)	-3 to +200	-14.7 to +150	0 to +300	-3 to +50	0 to +300	0 to +100
Auxiliary Cooling	No	No	No	No	Standard: air or liquid	Standard: liquid
Sensor Cavity Material	Epoxy-coated Aluminum	Stainless Steel	Stainless Steel	Anodized Aluminum	Stainless Steel	Stainless Steel
*Complete system at 25°C (77°F)						

[no content intended for this page]

## Appendix E. Glossary

### Depression Capability

The temperature difference by which the chilled mirror can be lowered from the ambient temperature.

### Network

A Local Area computer Network (LAN) or Wide Area Network (WAN) such as the Internet. The Optica can be operated or programmed remotely over a network.

### PACER

Panametrics patented *Programmable Automatic Contaminant Error Reduction* system, which consolidates soluble contaminants to reduce their effect on system accuracy (see *"The PACER Cycle"* on page 6).

### Parameter

A measured quantity available for display by the unit, such as Dew Point in °C, Humidity in Grams/Kilograms, or Pressure in Bar.

### Process Pressure

The gas pressure of the system under test. In some applications, humidity of this gas may be measured at a lower pressure.

### Scaling

The process of selecting the maximum and minimum output values of a chosen parameter.

### SHIFT

Pressing the **SHIFT** key enters *Shift Key* mode, reversing the direction of the cursor motion when pressing **TAB**, and accessing the non-numeric characters on the keypad.

### Softkeys

The four keys to the right of the display. The functions of these keys change depending on the context, and the current function is displayed to the left of each key.

### VGA

*Video Graphics Array*: Generic description of a 640 by 480 pixel display. Used to identify the *large-screen* Optica.

### 4x40

A display with four lines by 40 characters per line. Used to identify the *small-screen* Optica.

[no content intended for this page]

## Appendix F. Automatic Balance (for earlier software versions)

### F.1 Programming Automatic Balance for a VGA Optica

**Note:** For Optica Analyzers with software version 1.4.1a or later, see “Automatic Cleaning and Balance Function” on page 43.

**Table 38: Automatic Balancing Options**

Item	Function	Available Options
Interval	Set how often the automatic balance takes place.	Enter the interval in minutes (60 minutes minimum).
Type	Set the type of balance (see “Sensor Balancing” on page 34).	Auto, PACER
Status	Set whether the balance will take place.	Enabled, Disabled
Track/Hold	Set whether the display, analog outputs, and alarms will track the sensor condition during a cleaning cycle, or hold the last process reading. (Serial outputs always hold the process reading).	Track, Hold

### F.2 Programming Automatic Balance for a 4x40 Optica

**Note:** For Optica Analyzers with software version 1.4.1a or later, see “Automatic Cleaning and Balance Function” on page 43.

**Table 39: Automatic Balancing Options**

Setting	Description	Available Options
Interval	Set how often the balance takes place.	Enter the interval in minutes (60 minutes minimum).
Type	Set the type of balance (see “Sensor Balancing” on page 34).	Auto, PACER
Enable	Set whether the balance will take place.	Enabled, Disabled
Analog Output Tracking	Set whether display, analog outputs and alarms will track the sensor condition during a cleaning cycle, or hold the last process reading. (Serial output will always track the process reading.)	Track, Hold

[no content intended for this page]



## Appendix G. Communicating with the OPTICA Using Ethernet

### G.1 Direct Communication

The networking configuration for an **OPTICA VGA** model can be done using the front panel. The networking configuration for a **4x40 Optica** model with Ethernet capability can be configured using the RS-232 port and the following commands:

**Note:** <> means carriage return.

`$SetIPAddress <IPADDRESS><>` (i.e 127 0 0 0)\r\n

Example: `$SetIpAddress 127 0 0 0 0 <>`

`$SetSubnetMask <SubNetMask>` (i.e 255 255 255 0)\r\n

Example: `$SetSubnetMask 255 255 255 0 <>`

`$SetDefaultGateway <Gateway>` (i.e 0 0 0 0)\r\n

`$SetHostName <HostName><>` (i.e Optica)\r\n

`$SetIPSource <STATIC><>` (STATIC IP)\r\n

`$SetIPSource <DHCP><>` (DHCP IP)\r\n

`$GetNetworkSettings<>` Displays the network settings\r\n

`$SaveNetworkSettings<>`  
(Write Network settings to the registry)\r\n

`$DeleteNetworkSettings<>`  
(Deletes registry entries - removes .FDF & .CRC File)\r\n

`$SaveAllSettings<>`  
(Write all settings to non-volatile memory)\r\n

### G.2 Computer Communication

The Optica communicates over port 28005. The general format for accessing the Optica is:

<IP address>:28005/Command

The command set of the Optica is broken into two categories: Those used to *set* parameters and those used to *retrieve* parameters from the Optica. Commands that are used to retrieve information from the Optica are preceded with the prefix **Get**, and those that are used to set parameters at the Optica are preceded with the prefix **Set**. Only the commands that enable the user to retrieve information from the Optica are detailed in this document. The examples below assume that a web browser is being used.

#### G.2.1 Determining the Available Commands

The available commands can be determined by entering the line below in the address line of the browser. This command returns a list of API commands supported by the Optica.

`http://3.112.160.36:28005/OpticaAPI.xml`

```
<?xml version="1.0" encoding="UTF-8" standalone="yes" ?>
<OpticaAPIInfo>

  <help>---- OpticaAPI.xml?FunctionName+channel ----</help>
  <OpticaAPI>GetAlarmData</OpticaAPI>
  <OpticaAPI>GetAlarmTypes</OpticaAPI>
  <OpticaAPI>GetAllGraphingData</OpticaAPI>
  <OpticaAPI>GetAllLabels</OpticaAPI>
```

```

<OpticaAPI>GetAnalogOutData</OpticaAPI>
<OpticaAPI>GetAutoBalanceTypes</OpticaAPI>
<OpticaAPI>GetChannelInfo</OpticaAPI>
<OpticaAPI>GetCurrentData</OpticaAPI>
<OpticaAPI>GetDataFields</OpticaAPI>
<OpticaAPI>GetDataLogSettings</OpticaAPI>
<OpticaAPI>GetHTPLLabels</OpticaAPI>
<OpticaAPI>GetHTPPParam</OpticaAPI>
<OpticaAPI>GetPressureData</OpticaAPI>
<OpticaAPI>GetOpticalInfo</OpticaAPI>
<OpticaAPI>GetSerialCommData</OpticaAPI>
<OpticaAPI>GetSerialData</OpticaAPI>
<OpticaAPI>GetSupportedBaudRate</OpticaAPI>
<OpticaAPI>GetSupportedDataBits</OpticaAPI>
<OpticaAPI>GetSupportedSerialDataFormat</OpticaAPI>
<OpticaAPI>GetSupportedDataLogDataFormat</OpticaAPI>
<OpticaAPI>GetUserDefinedEquations</OpticaAPI>
<OpticaAPI>UpdateGraphingData</OpticaAPI>
<help>---- Set functions are not accessible with GET ----</help>
<OpticaAPI>SetAlarmData</OpticaAPI>
<OpticaAPI>SetAlarmTypes</OpticaAPI>
<OpticaAPI>SetAnalogOutData</OpticaAPI>

<OpticaAPI>SetAutoBalanceTypes</OpticaAPI>
<OpticaAPI>SetChannelInfo</OpticaAPI>
<OpticaAPI>SetCoolState</OpticaAPI>
<OpticaAPI>SetCurrentData</OpticaAPI>
<OpticaAPI>SetDataFields</OpticaAPI>
<OpticaAPI>SetDataLogSettings</OpticaAPI>
<OpticaAPI>SetHeatState</OpticaAPI>
<OpticaAPI>SetHTPLLabels</OpticaAPI>
<OpticaAPI>SetHTPPParam</OpticaAPI>
<OpticaAPI>SetPacerOn</OpticaAPI>
<OpticaAPI>SetPressureData</OpticaAPI>
<OpticaAPI>SetOpticalInfo</OpticaAPI>
<OpticaAPI>SetSerialCommData</OpticaAPI>
<OpticaAPI>SetSerialData</OpticaAPI>
<OpticaAPI>SetSupportedBaudRate</OpticaAPI>
<OpticaAPI>SetSupportedDataBits</OpticaAPI>
<OpticaAPI>SetSupportedSerialDataFormat</OpticaAPI>
<OpticaAPI>SetUserDefinedEquations</OpticaAPI>
</OpticaAPIInfo>

```

## G.2.2 Retrieving the Alarm Settings

Command: <http://3.112.160.36:28005/OpticaAPI.xml?GetAlarmData+0>

Function Name: GetAlarmData

Channel: 0

Response:

```

<?xml version="1.0" encoding="UTF-8" standalone="yes" ?>
<OpticaAPIReturn Function="GetAlarmData">
<channel>0</channel>

<AlarmType>2</AlarmType>
<Enabled>true</Enabled>
<UnitOffset>2</UnitOffset>
<type>2</type>
<LowerLimit>30.000000</LowerLimit>
<UpperLimit>60.000000</UpperLimit>

<AlarmType>2</AlarmType>
<Enabled>true</Enabled>
<UnitOffset>17</UnitOffset>
<type>17</type>

```

```
<LowerLimit>18.000000</LowerLimit>
<UpperLimit>26.000000</UpperLimit>
<retval>GEIAPI_SUCCESS</retval>
</OpticaAPIReturn
```

The Optica supports two alarm set points: The above response shows the settings for alarm 1 and alarm 2 in that order. (Note that the index is referenced from 0 , not 1). Alarm 1 parameters are described below.

### Alarm 1 Settings:

Alarm type = **2**  
 (SetPoint, InnerBand, Outerband, Control, Service, Pacer)  
**2** here indicates Outerband

Enabled = **True** (Alarm 1 is enabled.)

Unit Offset = **2** (% RH)  
 See the Optica manual or use the GetHTPLabels for the list of available units and the order.

Type = **2** ( ignore this value)

LowerLimit = **18.000000** (the Lower limit is 18 %RH)

UpperLimit = **26.000000** (The Upper limit is 26 %RH)

### G.2.3 Retrieving the Alarm Types

This command enables the user to retrieve different alarm types that are supported by the Optica, and the order in which they are referenced.

Command: <http://3.112.160.36:28005/OpticaAPI.xml?GetAlarmTypes>

Function Name: GetAlarmTypes

Channel: 0

Response:

```
<?xml version="1.0" encoding="UTF-8" standalone="yes" ?>
<OpticaAPIReturn Function="GetAlarmTypes">
  <NumAlarmTypes>6</NumAlarmTypes>
  <AlarmType>SetPoint</AlarmType>
  <AlarmType>Inner Band</AlarmType>
  <AlarmType>Outer Band</AlarmType>
  <AlarmType>Control</AlarmType>
  <AlarmType>Service</AlarmType>
  <AlarmType>Pacer</AlarmType>
  <retval>GEIAPI_SUCCESS</retval>
</OpticaAPIReturn>
```

This Response indicates that 6 alarm types are supported. They are listed in order, with the reference being 0.

### G.2.4 Retrieving Supported Units

This command enables the user to retrieve different units that are supported by the Optica and the order in which they are referenced.

Command: <http://3.112.160.36:28005/OpticaAPI.xml?GetAllLabels>

Function Name: GetAlarmTypes

Channel: 0

Response:

```
<?xml version="1.0" encoding="UTF-8" standalone="yes" ?>
<OpticaAPIReturn Function="GetAllLabels">
  <channel>0</channel>
  <sLabels>Tdew °C</sLabels>
  <sLabels>Tdew °F</sLabels>
```

```

<sLabels>%RH</sLabels>
<sLabels>Twet °C</sLabels>
<sLabels>Twet °F</sLabels>
<sLabels>ppmv</sLabels>
<sLabels>ppmw</sLabels>
<sLabels>Grains/lb</sLabels>
<sLabels>Grains/SCF</sLabels>
<sLabels>g/kg</sLabels>
<sLabels>g/m3</sLabels>
<sLabels>lb/Mft3</sLabels>
<sLabels>Kj/Kg (0)</sLabels>
<sLabels>Kj/Kg (32)</sLabels>
<sLabels>Btu/lb (0)</sLabels>
<sLabels>Btu/lb (32)</sLabels>
<sLabels>pw(mbar)</sLabels>
<sLabels>Tmp °C</sLabels>
<sLabels>Tmp °F</sLabels>
<sLabels>Tmp °K</sLabels>
<sLabels>Tmp °R</sLabels>
<sLabels>psia</sLabels>
<sLabels>mbar</sLabels>
<sLabels>bar</sLabels>
<sLabels>Pa</sLabels>
<sLabels>kPa</sLabels>
<sLabels>mmHg</sLabels>
<sLabels>inHg</sLabels>
<sLabels>KgCm2</sLabels>
<sLabels>DyneCm2</sLabels>
<sLabels />
<sLabels>UserEquation2</sLabels>
<sLabels>UserEquation3</sLabels>
<retval>GEIAPI_SUCCESS</retval>
</OpticaAPIReturn>

```

## G.2.5 Retrieving Labels and Functions

This command enables the user to retrieve different units that are supported by the Optica, and the order in which they are referenced. It also indicates which labels are humidity labels, temperature labels and pressure labels.

Command: <http://3.112.160.36:28005/OpticaAPI.xml?GetHTPLabels+0>

Function Name: GetHTPLables

Channel: 0

Response:

```

<?xml version="1.0" encoding="UTF-8" standalone="yes" ?>
<OpticaAPIReturn Function="GetHTPLabels">
<channel>0</channel>
<iHumidityLabels>17</iHumidityLabels>
<sHumidityLabels>Tdew °C</sHumidityLabels>
<sHumidityLabels>Tdew °F</sHumidityLabels>
<sHumidityLabels>%RH</sHumidityLabels>
<sHumidityLabels>Twet °C</sHumidityLabels>
<sHumidityLabels>Twet °F</sHumidityLabels>
<sHumidityLabels>ppmv</sHumidityLabels>
<sHumidityLabels>ppmw</sHumidityLabels>
<sHumidityLabels>Grains/lb</sHumidityLabels>
<sHumidityLabels>Grains/SCF</sHumidityLabels>
<sHumidityLabels>g/kg</sHumidityLabels>
<sHumidityLabels>g/m3</sHumidityLabels>
<sHumidityLabels>lb/Mft3</sHumidityLabels>
<sHumidityLabels>kj/kg (0)</sHumidityLabels>
<sHumidityLabels>kj/kg (32)</sHumidityLabels>
<sHumidityLabels>Btu/lb (0)</sHumidityLabels>
<sHumidityLabels>Btu/lb (32)</sHumidityLabels>
<sHumidityLabels>pw(mbar)</sHumidityLabels>

```

```

<iTemperatureLabels>4</iTemperatureLabels>
<sTemperatureLabels>Tmp °C</sTemperatureLabels>
<sTemperatureLabels>Tmp °F</sTemperatureLabels>
<sTemperatureLabels>Tmp °K</sTemperatureLabels>
<sTemperatureLabels>Tmp °R</sTemperatureLabels>
<iPressureLabels>9</iPressureLabels>
<sPressureLabels>psia</sPressureLabels>
<sPressureLabels>mbar</sPressureLabels>
<sPressureLabels>bar</sPressureLabels>
<sPressureLabels>Pa</sPressureLabels>
<sPressureLabels>kPa</sPressureLabels>
<sPressureLabels>mmHg</sPressureLabels>
<sPressureLabels>inHg</sPressureLabels>
<sPressureLabels>kg/cm2</sPressureLabels>
<sPressureLabels>DyneCm2</sPressureLabels>
<iUserLabels>3</iUserLabels>
<sUserLabels />

<sUserLabels>UserEquation2</sUserLabels>
<sUserLabels>UserEquation3</sUserLabels>
<iLabels>33</iLabels>
<sLabels>Tdew °C</sLabels>
<sLabels>Tdew °F</sLabels>
<sLabels>%RH</sLabels>
<sLabels>Twet °C</sLabels>
<sLabels>Twet °F</sLabels>
<sLabels>ppmv</sLabels>
<sLabels>ppmw</sLabels>
<sLabels>Grains/lb</sLabels>
<sLabels>Grains/SCF</sLabels>
<sLabels>g/kg</sLabels>
<sLabels>g/m3</sLabels>
<sLabels>lb/Mft3</sLabels>
<sLabels>Kj/Kg (0)</sLabels>
<sLabels>Kj/Kg (32)</sLabels>
<sLabels>Btu/lb (0)</sLabels>
<sLabels>Btu/lb (32)</sLabels>
<sLabels>pw(mbar)</sLabels>
<sLabels>Tmp °C</sLabels>
<sLabels>Tmp °F</sLabels>
<sLabels>Tmp °K</sLabels>
<sLabels>Tmp °R</sLabels>
<sLabels>psia</sLabels>
<sLabels>mbar</sLabels>
<sLabels>bar</sLabels>
<sLabels>Pa</sLabels>
<sLabels>kPa</sLabels>
<sLabels>mmHg</sLabels>
<sLabels>inHg</sLabels>
<sLabels>KgCm2</sLabels>
<sLabels>DyneCm2</sLabels>
<sLabels />
<sLabels>UserEquation2</sLabels>
<sLabels>UserEquation3</sLabels>
<HumidityUnitsBaseIndex>0</HumidityUnitsBaseIndex>
<TemperatureUnitsBaseIndex>17</TemperatureUnitsBaseIndex>
<PressureUnitsBaseIndex>21</PressureUnitsBaseIndex>
<UserUnitsBaseIndex>30</UserUnitsBaseIndex>
<retval>GEIAPI_SUCCESS</retval>
</OpticaAPIReturn>

```

This response indicates how many humidity labels (iHumidityLabels), temperature labels (iTemperatureLabels), pressure labels (iPressureLabels) and UserLabels there are. The iLabels value indicates how many labels there are all together (33).

## G.2.6 Retrieving Analog Output Information

This command enables the user to retrieve settings for the two analog outputs.

Command: <http://3.112.160.36:28005/OpticaAPI.xml?GetAnalogOutData+0>

Function Name: GetAnalogOutData

Channel: 0

Response:

```
<?xml version="1.0" encoding="UTF-8" standalone="yes" ?>
<OpticaAPIReturn Function="GetAnalogOutData">
  <channel>0</channel>
  <UnitOffset>0</UnitOffset>
  <LowerLimit>-40.000000</LowerLimit>
  <UpperLimit>60.000000</UpperLimit>
  <UnitOffset>17</UnitOffset>
  <LowerLimit>0.000000</LowerLimit>
  <UpperLimit>100.000000</UpperLimit>
  <retval>GEIAPI_SUCCESS</retval>
</OpticaAPIReturn>
```

UnitOffset is an index to the list of labels. In this case **0** refers to **Tdew °C**

## G.2.7 Retrieving the Measured and Calculated Values

This command enables the user to retrieve measured and calculated values for all supported units. The status information is also returned.

Command: [http://3.112.160.36:28005/OpticaAPI.xml?GetCurrentData+0\\_](http://3.112.160.36:28005/OpticaAPI.xml?GetCurrentData+0_)

Function Name: GetCurrentData

Channel: 0

Response:

```
<?xml version="1.0" encoding="UTF-8" standalone="yes" ?>
<OpticaAPIReturn Function="GetCurrentData">
  <channel>0</channel>
  <channelName />
```

**Note:** *iNumber is the number of data values returned.*

This number is the same as "iLabels" of GetHTPLabels and those labels coincide with these values.

```
<iNumber>33</iNumber>
<fAllData>-4.892536</fAllData>
<fAllData>23.193436</fAllData>
<fAllData>16.158667</fAllData>
<fAllData>9.333572</fAllData>

<fAllData>48.800430</fAllData>
<fAllData>4014.087158</fAllData>
<fAllData>2496.681885</fAllData>
<fAllData>17.476774</fAllData>
<fAllData>6.832514</fAllData>
<fAllData>2.496682</fAllData>
<fAllData>2.985780</fAllData>
<fAllData>186.449982</fAllData>
<fAllData>43.695812</fAllData>
<fAllData>26.523333</fAllData>
<fAllData>19.541956</fAllData>
<fAllData>11.861956</fAllData>
<fAllData>4.055074</fAllData>
<fAllData>21.146547</fAllData>
<fAllData>70.100189</fAllData>
<fAllData>294.306549</fAllData>
<fAllData>529.753784</fAllData>
```

```

<fAllData>14.710732</fAllData>
<fAllData>1014.265686</fAllData>
<fAllData>1.014266</fAllData>
<fAllData>101426.570313</fAllData>
<fAllData>101.426567</fAllData>
<fAllData>760.761841</fAllData>
<fAllData>29.239281</fAllData>
<fAllData>1.034267</fAllData>
<fAllData>1014265.687500</fAllData>
<fAllData>0.401409</fAllData>
<fAllData>0.000000</fAllData>
<fAllData>0.000000</fAllData>
<iBarGraphMin>0</iBarGraphMin>
<iBarGraphMax>10</iBarGraphMax>
<iBarGraphValue>6</iBarGraphValue>
<bHeatState>false</bHeatState>
<bCoolState>false</bCoolState>
<bPacerState>false</bPacerState>
<sStatus>Control Alarm1</sStatus>
<retval>GEIAPI_SUCCESS</retval>
</OpticaAPIReturn>

```

bHeatState, bCoolState and bPacerState indicate whether the unit is in MaxHeat, MaxCool, or Pacer, respectively.

## G.2.8 4X40 Optica Configuration

Using an RS-232 communication link, the user can set the network settings. To see the set of supported commands, type "\$Help<>"

1. **\$SetIPAddress <IP ADDRESS><>**  
(i.e., \$SetIPAddress 3 112 60 36)
2. **\$SetIPSource <STATIC><>** (Assuming STATIC IP)
3. **\$SaveNetworkSettings<>**
4. **\$GetNetworkSettings<>** (Displays the current network settings)

It takes time to execute the "SaveNetworkSettings" command. Wait until the display updates to determine when to reset the unit. In order for the settings to take effect, power to the unit must be cycled.

[no content intended for this page]



<b>A</b>		<b>D</b>	
Accessory Specifications .....	79	Data Fields	
Alarm Outputs		4x40 Optica .....	59
Inner Band Alarm .....	17	VGA Optica .....	44
Outer Band Alarm .....	17	Default Settings .....	33
Set Point Alarm .....	17	Definitions .....	91
Wiring .....	16	Depression Capability .....	87, 91
Alarms		Dew Point	
4x40 Optica .....	58	High Measurements .....	20
Retrieving Settings with Ethernet .....	96	Sampling Lines .....	20
Retrieving Types with Ethernet .....	97	Supercooled .....	34
VGA Optica .....	42	Direct Communication with Ethernet .....	95
Analog Outputs		Display	
4x40 Optica .....	56	"Balance" Displayed .....	76
Retrieving Information with Ethernet .....	100	Incorrect Dew Point .....	75
Troubleshooting .....	76	Troubleshooting .....	74
VGA Optica .....	41	VGA .....	91
Wiring .....	15	Document Number .....	i
Automatic Balance		<b>E</b>	
4x40 Optica (earlier software) .....	93	Electronics Enclosure	
VGA Optica (earlier software) .....	93	Benchtop .....	1
Automatic Cleaning and Balancing		Wall-Mount .....	1
4x40 Optica .....	60	Enclosure	
VGA Optica .....	43	Benchtop, Installation .....	7
<b>B</b>		Benchtop, Wiring .....	11
Balancing a Sensor .....	34	Rack Mount, Installation .....	8
Balancing, Automatic		Equipment, Auxiliary .....	vii
4x40 Optica .....	60	Ethernet	
4x40 Optica (earlier software) .....	93	4x40 Optica Configuration .....	101
VGA Optica .....	43	Alarm Settings .....	96
VGA Optica (earlier software) .....	93	Alarm Types .....	97
Benchtop		Analog Output Information .....	100
Specifications .....	79	Available Commands .....	95
Wiring Input Power .....	11	Direct Communication .....	95
Wiring Outputs .....	14	Labels and Functions .....	98
Wiring Sensors .....	11	Measured and Calculated Values .....	100
<b>C</b>		Supported Units .....	97
Calibration .....	74	Using a Computer .....	95
Chilled Mirror Sensors .....	87	<b>F</b>	
Cleaning Sensor Mirror .....	69	Filters .....	20
Cleaning, Automatic		Flow Rate .....	20
4x40 Optica .....	60	Functional Specifications .....	78
VGA Optica .....	43	Functions	
Communication Parameters		Retrieving with Ethernet .....	98
4x40 Optica .....	56	<b>G</b>	
Setting with Ethernet .....	95	Gaseous Contaminants .....	35
Computer Communication with Ethernet .....	95	General Settings	
Configuration Files, Saving .....	52	4x40 Optica .....	62
Contamination		VGA Optica .....	48
Gaseous Contaminants .....	35	Glossary .....	91
Minimizing the Effects .....	35	<b>H</b>	
Mirror Cleanliness .....	34	Heat Pump Controller Settings .....	24
Particulate Matter .....	34	Humidity	
Water-Soluble Contaminants .....	34	Conversion Chart .....	83
Coolant		Equations .....	82
Model 1311XR Sensor .....	23	Symbols .....	81

Humidity Equations	
Vapor Pressure	81
Hygrometer	
Applications	5
Calibration	5
Diagram	4
Function	4
	<b>I</b>
Information Paragraphs	vii
Inner Band Alarm	17
Inputs	2
Installation	
Benchtop	7
Rack Mount	8
Sampling Lines	19
Sensors	21
Wall-Mount	12
Wall-Mount Wiring	13
	<b>M</b>
Maintenance	
Calibration	74
Cleaning the Sensor Mirror	69
Replacing Sensor Mirrors	73
Sample Line	35
Sensor Optics	69
Testing	74
Troubleshooting	74
Measurement	
At a Different Pressure	29
Dew Point	30, 32
High Dew Point	20
Process Pressure	29, 30, 31
Range	88
Ranges	1
Retrieving Values with Ethernet	100
Units of Measure	39
Vapor Pressure with a Sensor	30, 31
Vapor Pressure without a Sensor	30, 31
Mirror	
Cleaning	69
Flooding	35
Mirror, Cleaning and Balancing	69
Model 1311XR Sensor	23
Control Knob	24
Coolant	23
Electrical Connections	23
Error Indicators	24
Heat Pump Controller Settings	24
Purging the Sensor	24
Sample Gas Fittings	23
Model SIM-12H Sensor	25
	<b>N</b>
Network	
Definition	91
Menu	45
Operation	28
Screen	28
Network-Based Programming	65
	<b>O</b>
Operation	
4x40 Optica	28
Helpful Hints	34
Network	28
Normal	27
Theory of	4
VGA Optica	27
Optica 4x40	
Alarms	58
Analog Outputs	56
Automatic Balance	93
Buzzer and Sounds	62
Communication Parameters	56
Configuration with Ethernet	101
Data Fields	59
Definition	91
Display Screen	28
Factory Calibrations	63
General Settings	62
Operation	28
Pressure Input	59
Programmable Functions	56
Programming	53
Serial Output Setup	57
Serial Outputs	57
Setting Time and Date	62
Special Options	63
User Default Settings	63
User Equations	62
Outer Band Alarm	17
Outputs	2
	<b>P</b>
PACER	
Cycle	6
Definition	91
Parameter Definition	91
Particulate Contaminants	34
Performance	77
Pressure	
Effects	35
Manually Entering	29
Measuring	29
Process	29
Vapor	81
Pressure Input	
4x40 Optica	59
VGA Optica	42
Process Pressure	29
Definition	91
Measuring	29
Programming	
4x40 Optica	53
Network-Based	65
VGA Optica	37
	<b>R</b>
Return Policy	107
	<b>S</b>
Safety Equipment, Personal	vii
Sample Gas Fittings	
Model 1311XR Sensor	23



[no content intended for this page]

---

## Warranty

Each instrument manufactured by Panametrics is warranted to be free from defects in material and workmanship. Liability under this warranty is limited to restoring the instrument to normal operation or replacing the instrument, at the sole discretion of Panametrics. Fuses and batteries are specifically excluded from any liability. This warranty is effective from the date of delivery to the original purchaser. If Panametrics determines that the equipment was defective, the warranty period is:

- one year from delivery for electronic or mechanical failures
- one year from delivery for sensor shelf life

If Panametrics determines that the equipment was damaged by misuse, improper installation, the use of unauthorized replacement parts, or operating conditions outside the guidelines specified by Panametrics, the repairs are not covered under this warranty.

---

**The warranties set forth herein are exclusive and are in lieu of all other warranties whether statutory, express or implied (including warranties or merchantability and fitness for a particular purpose, and warranties arising from course of dealing or usage or trade).**

---

## Return Policy

If a Panametrics instrument malfunctions within the warranty period, the following procedure must be completed:

1. Notify Panametrics, giving full details of the problem, and provide the model number and serial number of the instrument. If the nature of the problem indicates the need for factory service, Panametrics will issue a RETURN AUTHORIZATION NUMBER (RAN), and shipping instructions for the return of the instrument to a service center will be provided.
2. If Panametrics instructs you to send your instrument to a service center, it must be shipped prepaid to the authorized repair station indicated in the shipping instructions.
3. Upon receipt, Panametrics will evaluate the instrument to determine the cause of the malfunction.

Then, one of the following courses of action will then be taken:

- If the damage is covered under the terms of the warranty, the instrument will be repaired at no cost to the owner and returned.
- If Panametrics determines that the damage is not covered under the terms of the warranty, or if the warranty has expired, an estimate for the cost of the repairs at standard rates will be provided. Upon receipt of the owner's approval to proceed, the instrument will be repaired and returned.

[no content intended for this page]

We,

**Panametrics  
1100 Technology Park Drive  
Billerica, MA 01821  
USA**

declare under our sole responsibility that the

**Optica® Dew Point Analyzer**

to which this declaration relates, is in conformity with the following standards:

- EN 61326-1: 2013, Group 1, Class A, Table 1, Basic EM Environments  
(For EN 61000-4-3 and EN 610004-6, the Optica meets performance criteria A and, in a limited number of frequencies, performance criteria B per EN 61326)
- EN 61326-2-3: 2006
- EN 61010-1: 2012, Overvoltage Category II

following the provisions of the 2004/108/EC EMC and 2006/95/EC Low Voltage Directives.

The unit listed above and any ancillary equipment supplied with it do not bear CE marking for the Pressure Equipment Directive, as they are supplied in accordance with Article 3, Section 3 (sound engineering practices and codes of good workmanship) of the Pressure Equipment Directive 97/23/EC for DN<25.

Billerica - September 1, 2015

Issued



Mr. Gary Kozinski  
Certification & Standards, Lead Engineer

[no content intended for this page]





## Customer Support Centers

### U.S.A.

The Boston Center  
1100 Technology Park Drive  
Billerica, MA 01821

U.S.A.

Tel: 800 833 9438 (toll-free)  
978 437 1000

E-mail: [mstechsupport@bakerhughes.com](mailto:mstechsupport@bakerhughes.com)

### Ireland

Sensing House  
Shannon Free Zone East  
Shannon, County Clare  
Ireland

Tel: +353 (0)61 470200

E-mail: [mstechsupport@bakerhughes.com](mailto:mstechsupport@bakerhughes.com)

Copyright 2022 Baker Hughes company.

This material contains one or more registered trademarks of Baker Hughes Company and its subsidiaries in one or more countries. All third-party product and company names are trademarks of their respective holders.

A40238752 G

**Baker Hughes** 