

DewPro[®] MMR31

Installation & Operation Manual



DewPro[®] MMR31

*Moisture Transmitter
(Mid-Range, 1 or 2 Current Loops)*

Installation & Operation Manual

A40251532 Rev. C
December 2015



gmeasurement.com

©2015 General Electric Company. All rights reserved.
Technical content subject to change without notice.

[no content intended for this page]

Information Paragraphs

Note: *These paragraphs provide information that provides a deeper understanding of the situation, but is not essential to the proper completion of the instructions.*

IMPORTANT: *These paragraphs provide information that emphasizes instructions that are essential to proper setup of the equipment. Failure to follow these instructions carefully may cause unreliable performance.*



CAUTION! This symbol indicates a risk of potential minor personal injury and/or severe damage to the equipment, unless these instructions are followed carefully.



WARNING! This symbol indicates a risk of potential serious personal injury, unless these instructions are followed carefully.

Safety Issues



WARNING! It is the responsibility of the user to make sure all local, county, state and national codes, regulations, rules and laws related to safety and safe operating conditions are met for each installation. The safety of any system incorporating the equipment is the responsibility of the assembler of the system.

Auxiliary Equipment

Local Safety Standards

The user must make sure that he operates all auxiliary equipment in accordance with local codes, standards, regulations, or laws applicable to safety.

Working Area



WARNING! Auxiliary equipment may have both manual and automatic modes of operation. As equipment can move suddenly and without warning, do not enter the work cell of this equipment during automatic operation, and do not enter the work envelope of this equipment during manual operation. If you do, serious injury can result.



WARNING! Make sure that power to the auxiliary equipment is turned OFF and locked out before you perform maintenance procedures on the equipment.



WARNING! It is the responsibility of the user to make sure the PWR, Hart, Modbus and I/O cable can meet the cable specification, which is described in Appendix A.

Qualification of Personnel

Make sure that all personnel have manufacturer-approved training applicable to the auxiliary equipment.

Personal Safety Equipment

Make sure that operators and maintenance personnel have all safety equipment applicable to the auxiliary equipment. Examples include safety glasses, protective headgear, safety shoes, etc.

Unauthorized Operation

Make sure that unauthorized personnel cannot gain access to the operation of the equipment.

Environmental Compliance

Waste Electrical and Electronic Equipment (WEEE) Directive

GE Measurement & Control is an active participant in Europe's *Waste Electrical and Electronic Equipment (WEEE)* take-back initiative, directive 2012/19/EU.



The equipment that you bought has required the extraction and use of natural resources for its production. It may contain hazardous substances that could impact health and the environment.

In order to avoid the dissemination of those substances in our environment and to diminish the pressure on the natural resources, we encourage you to use the appropriate take-back systems. Those systems will reuse or recycle most of the materials of your end life equipment in a sound way.

The crossed-out wheeled bin symbol invites you to use those systems.

If you need more information on the collection, reuse and recycling systems, please contact your local or regional waste administration.

Visit <https://www.gemeasurement.com/environmental-health-safety-ehs> for take-back instructions and more information about this initiative.

Chapter 1. General Information

1.1 Unpacking and Inspection 1

1.2 Model Number 1

1.3 Version Descriptions 3

1.4 Theory of Operation. 4

 1.4.1 First 4-20 mA Loop. 4

 1.4.2 Second 4–20 mA Loop 4

 1.4.3 Polymer Sensor 4

 1.4.4 Calibration. 4

Chapter 2. Installation

2.1 Mounting the MMR31 5

 2.1.1 Using a Compression Fitting or a Flange 6

 2.1.2 Using a Bracket. 7

2.2 Wiring Configurations with One Current Loop 8

 2.2.1 General Guidelines 8

 2.2.2 Normal Environments. 9

 2.2.3 Environments with Severe Electrical Noise 9

 2.2.4 General Wiring Instructions 10

2.3 Wiring Configurations with Two Current Loops 11

 2.3.1 General Guidelines 11

 2.3.2 Normal Environments. 12

 2.3.3 Environments with Severe Electrical Noise 12

 2.3.4 General Wiring Instructions 13

2.4 Selecting the Units of Measure 14

Chapter 3. Calibration and Troubleshooting

3.1 Calibration Using Two Saturated Salt Solutions 15

3.2 Calibration Steps 16

 3.2.1 Calibrating the Low RH Reading 17

 3.2.2 Calibrating the High RH Reading. 17

3.3 Troubleshooting 18

 3.3.1 Loop Current is Out of Range. 18

 3.3.2 No Loop Current. 18

 3.3.3 Slow Response Time. 18

 3.3.4 Frozen Output Current 18

Chapter 4. Optional Display/User Interface

4.1 Accessing the Programming Buttons19
 4.1.1 Removing the Display19
4.2 Programming the Matrix20
4.3 Matrix Buttons - Special Functions22
 4.3.1 Reset to “Normal” Display22
 4.3.2 Display Only22
 4.3.3 Default Values22
4.4 Matrix Functions.22
 4.4.1 System Administration Functions23
 4.4.2 Moisture Measurement Functions24
 4.4.3 4-20 mA Output Range Functions.25
 4.4.4 Temperature Measurement Functions26
 4.4.5 Error Codes27

Chapter 5. Specifications

5.1 Technical Specifications29
5.2 Optional Onboard Display with User Interface30
5.3 EMI/RFI Protection31
5.4 EMC Compliance31
5.5 Available Accessories31

Chapter 1. General Information

1.1 Unpacking and Inspection

Upon receipt of the DewPro MMR31, examine the shipping carton for broken or open packing, distortion, or any other evidence of mishandling. If your inspection indicates damage to the unit or any of its components may have occurred, notify the carrier within 15 days of delivery and request an inspection.

If no shipping damage is suspected, move the carton to a clean work area and unpack the contents. The carton you received should contain:

- DewPro MMR31 Instrument
- Installation and Operation Manual
- Calibration Certificate

1.2 Model Number

Locate the product label on your MMR31, and compare the last five characters of the model number with the product numbering structure shown on the next page. This will confirm that your MMR31 has been configured to your specifications. In the example shown in *Figure 1* below, the characters **R8A2A** indicate: *standard certification* (not certified), *G1/2 compression fitting* (male thread) with gasket and SS ferrule, protective cap with standard *100 micron sintered filter*, *enclosure conduit M20 x 1.5-F* with 1/2" NPT-F adapter and plug, and *one selectable 4-20 mA output* (RH 0-100% or dew point -15°C to $+85^{\circ}\text{C}$, absolute humidity, mixing ratio, no display, fault status 22 mA).

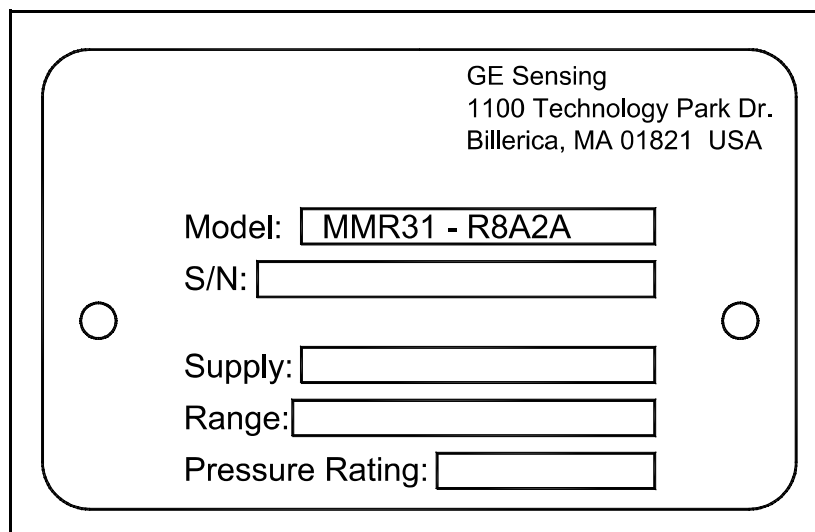
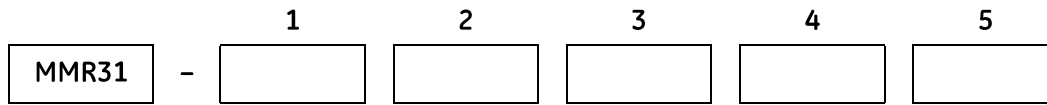

Figure 1: DewPro MMR31 Product Label

1.2 Model Number (cont.)



1 - Certification

- R. Standard Certification (not certified)
- S. Other

2 - Process Connection

- 1. 3" diameter galvanized floor flange with 12.7 mm (1/2" NPT-M) compression fitting
- 2. 3/4" NPT-M compression fitting
- 3. 1/2" NPT-M compression fitting
- 4. 3/4" x 16 "O" ring compression fitting (UNF thread)
- 6. No mounting hardware
- 8. G1/2 compression fitting (Male thread), gasket, SS ferrule
- S. Other

3 - Protective Cap

- A. Standard, with 100 micron sintered filter
- S. Other

4 - Enclosure Conduit

- 1. Enclosure Conduit M20 x 1.5-F with cable gland and plug
- 2. Enclosure Conduit M20 x 1.5-F with 1/2" FNPT adapter and plug
- S. Other

5 - Output Configuration/Dewpoint Range

- A. One output 4-20 mA selectable: RH 0-100% or dewpoint 15 to +85°C (5 to 185°F), absolute humidity, mixing ratio, no display, fault status 22 mA
- B. Two 4-20 mA DC output loops: 1st loop Moisture, 2nd loop temperature -15 to +85°C (5 to 185°F), no display, fault status 22 mA
- C. As A, fault status hold
- D. As A, fault status 3.6 mA
- E. As B, fault status hold
- F. As B, fault status 3.6 mA
- G. As A, with integral display, user interface
- H. As B, with integral display, user interface
- S. Other

1.3 Version Descriptions

The DewPro MMR31 mid-range moisture transmitter is available in two versions:

- *One isolated 4-20 mA current loop:* The loop current represents the selected *moisture* unit (see “*Selecting the Units of Measure*” on page 14).
- *Two isolated 4-20 mA loops:* The second loop current represents *temperature*. A unique patented feature of this version is that both loops can be powered by a single supply.

The MMR31 transmitter includes:

- Sensor element
- Stainless steel probe
- Weather-proof enclosure
- Microprocessor electronics

It is designed to be inserted directly into the process. Various mounting hardware, such as flange and compression fittings are available for mounting into a duct, process chamber, wall, etc. The DewPro MMR31 measures relative humidity in %, dew point temperature in °F or °C, absolute humidity in g/m³, or mixing ratio in g/kg. An optional display with user interface allows the user to configure the MMR31 (see Chapter 4, “*Optional Display/User Interface*” on page 19).

1.4 Theory of Operation

1.4.1 First 4-20 mA Loop

The MMR31 microcontroller-operated electronics operates with a voltage supply of 12 to 28 VDC. At the nominal 24 VDC supply, the maximum loop resistance is 600 ohms. The signal is represented by the 4 to 20 mA loop current and is directly proportional to 0 to 100% relative humidity, or, if selected, the dew point temperature range of 5 to 185°F (-15 to +85°C), the absolute humidity in a range of 1 to 350 g/m³, or the mixing ratio in a range of 1 to 830 g/kg.

1.4.2 Second 4-20 mA Loop

The specifications for the first loop current are also valid for the second loop current, except that the 4 to 20mA signal always corresponds to the temperature range of 5 to 185°F (-15 to +85°C).

1.4.3 Polymer Sensor

The sensing element in the MMR31 is a silicon-based polymer that uses the capacitance principle for the moisture measurement. The IC chip includes the moisture sensor and appropriate integrated circuitry. A platinum RTD temperature sensor is built in to provide temperature compensation for maximum accuracy. The sensor element is protected from condensation using a hydrophobic sintered filter. An additional removable filter cap serves as a pre-filter.

1.4.4 Calibration

Each MMR31 is factory-calibrated against precise NIST certified moisture references. Field calibration is possible with the use of saturated salt solutions (refer to Chapter 3, “*Calibration and Troubleshooting*” on page 15).

Chapter 2. Installation

To properly install your MMR31, carefully follow the instructions in this chapter.

2.1 Mounting the MMR31

To select a suitable mounting location, refer to the dimensions shown in *Figure 2* below.

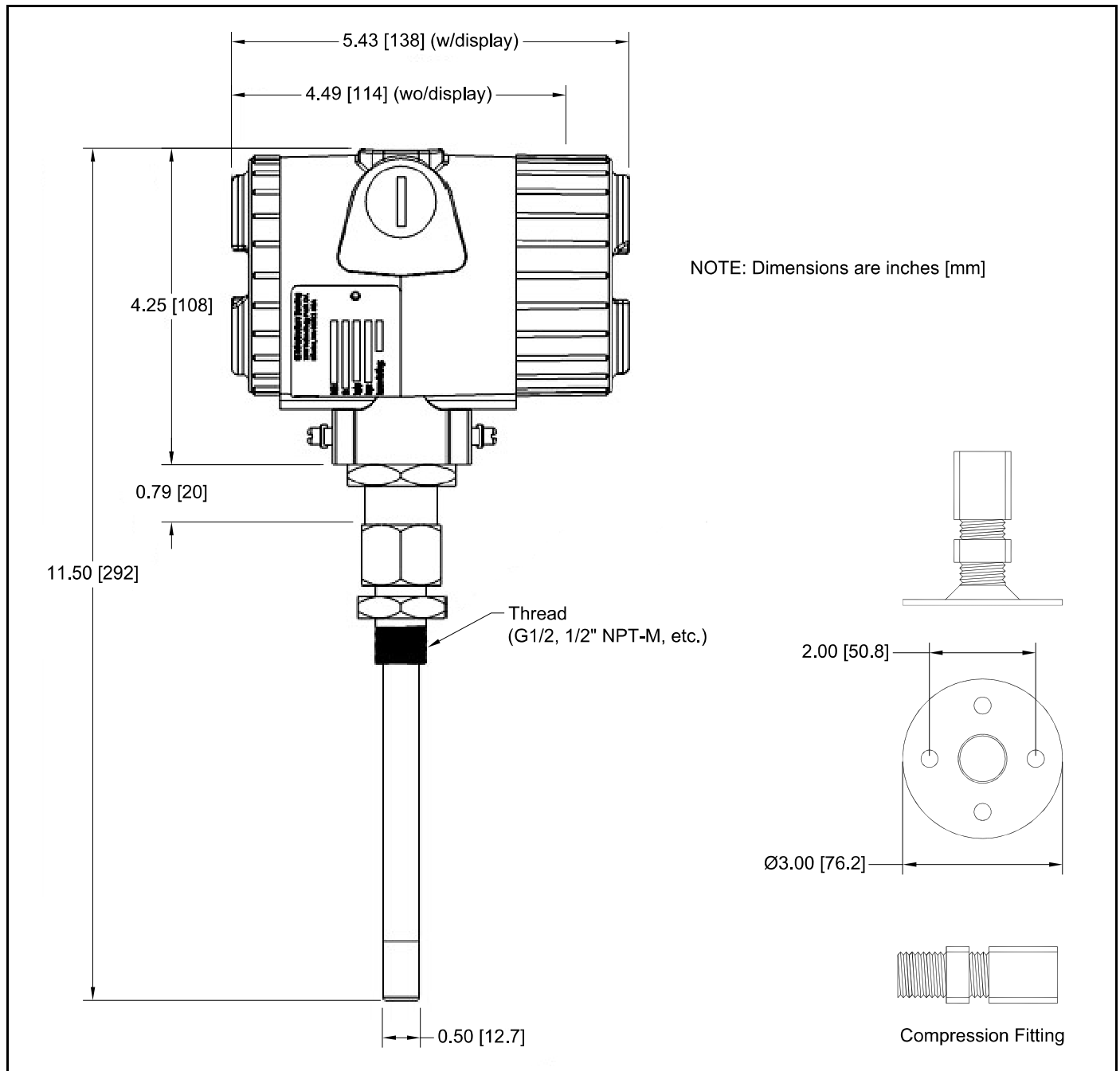

Figure 2: MMR31 and Compression Fitting Dimensions

2.1.1 Using a Compression Fitting or a Flange

IMPORTANT: *Be certain that the tip of the probe does not touch the inside wall of the pipe or container.*

IMPORTANT: *A 1.4571 stainless steel ferrule is required for use in pressurized systems. Ensure that your probe has the appropriate fitting for your application.*

To monitor moisture inside a pipe or container, mount the probe using a compression fitting connection or a flange (see *Figure 3* below). Adjust the ferrule for a probe insertion length of at least 1 in. (25 mm) and tighten the compression fitting as follows:

1. Hand-tighten the nut.
2. Use a wrench to tighten the nut 1-1/2 turns. When tightened in this manner, the fitting with a stainless steel ferrule can withstand pressures up to 17 bar (250 psi).

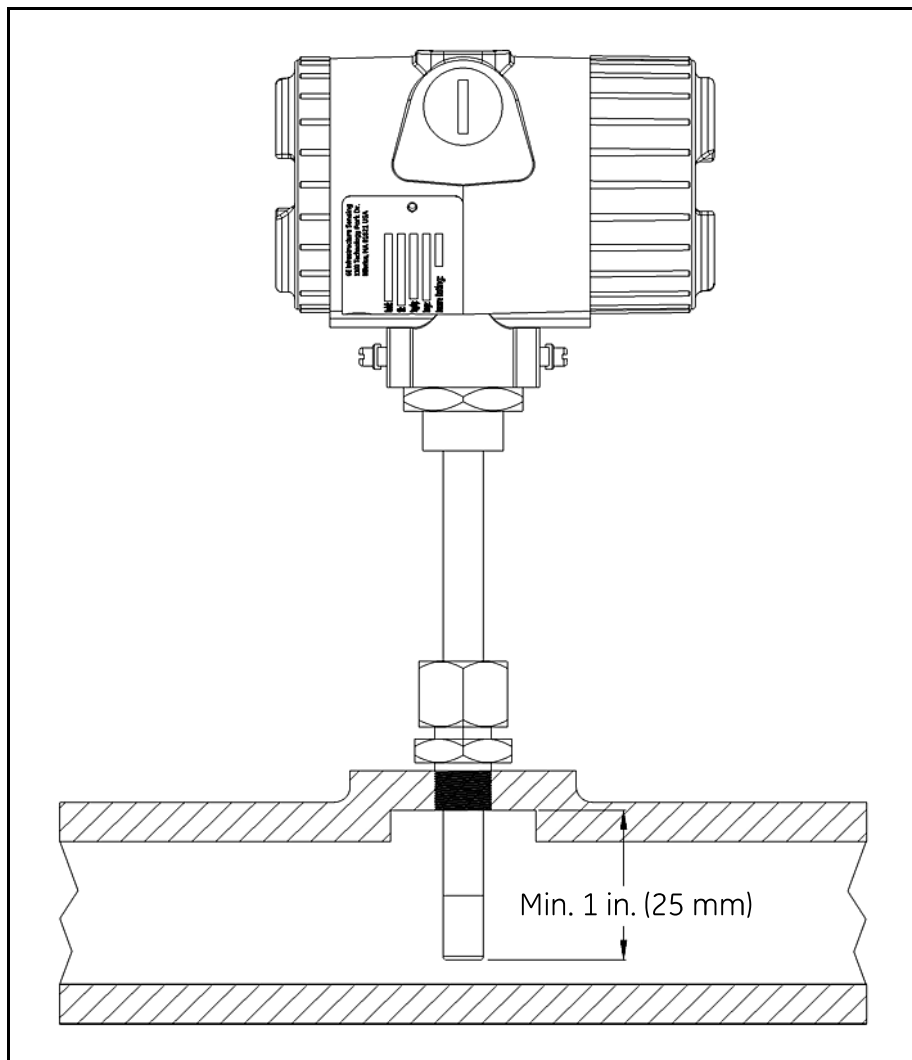

Figure 3: Mounting the Probe in a Pipe

2.1.2 Using a Bracket

The MMR31 can be used to monitor the air in a room or other such area, by using the available mounting kits shown in *Figure 4* below.

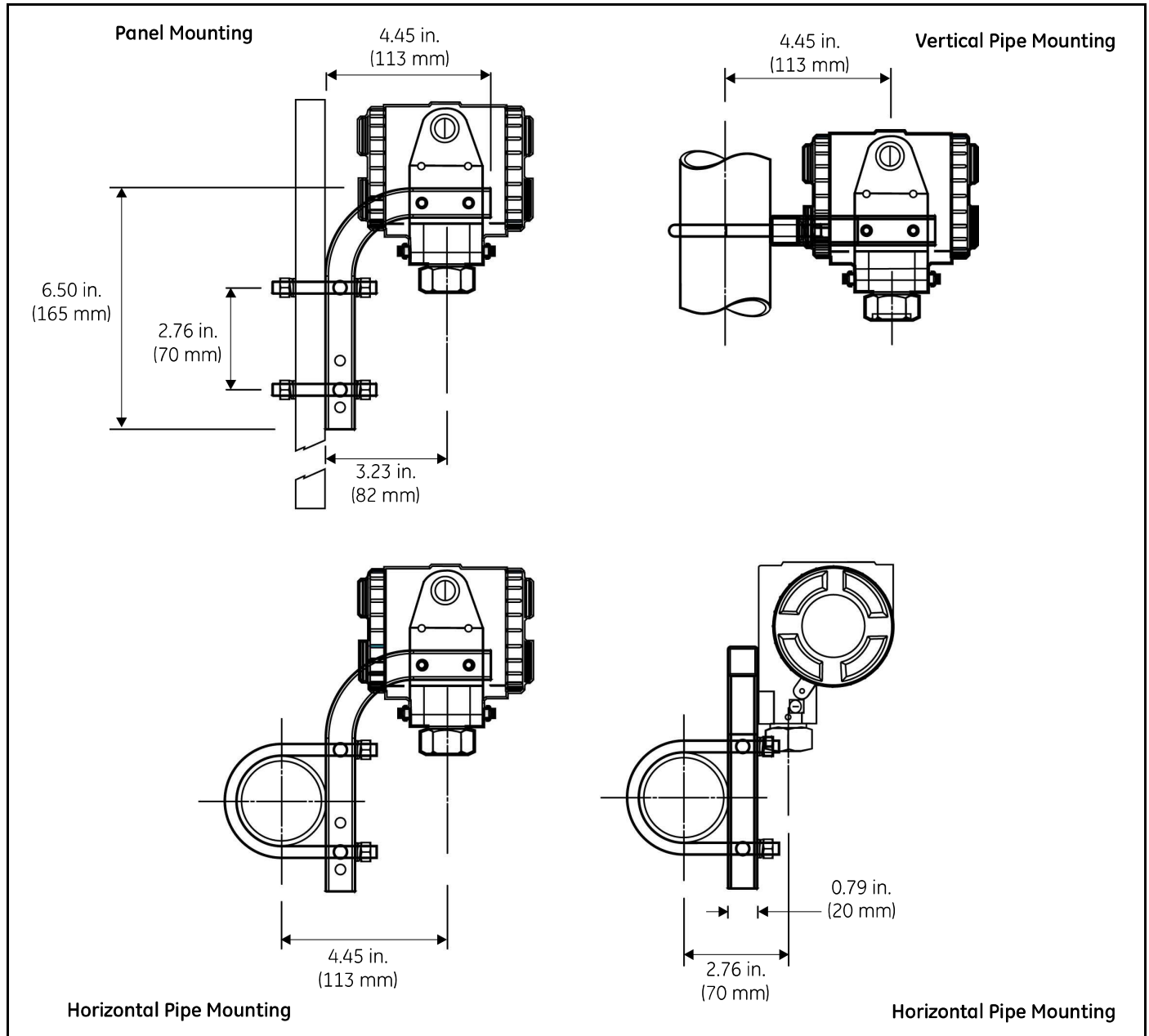

Figure 4: Mounting Kit Configurations

2.2 Wiring Configurations with One Current Loop



CAUTION! The MMR31 system contains electronic components that are susceptible to damage by static electricity. Proper handling procedures must be observed during the removal, installation, or other handling of internal circuit boards.

2.2.1 General Guidelines

The maximum loop resistance is an important parameter for selection of the supply voltage, because each device connected to the loop causes a voltage drop. For instance, using a loop-powered display with an input impedance of 50 ohms will cause a voltage drop of 1 VDC at 20 mA, per Ohm's law ($V = R \times I = 50 \times 0.020 = 1$). Similarly, connecting the loop to a Programmable Logic Controller (PLC) will cause a voltage drop across its input.

When designing your loop, add up all voltage drops across the devices connected to the loop and then add 12 V. This sum is the minimum supply voltage required for the circuit. To ensure reliable operation, it is recommended that a 20% safety factor be added to the calculated voltage requirement.

IMPORTANT: *The voltage across the + and - terminals of the MMR31 should not fall below 12 VDC.*

If an external display is used, configure it to the proper range: 0-100% RH, 5 to 185°F (–15 to +85°C) dew point, 1 to 350 g/m³ absolute humidity, 1 to 830 g/kg mixing ratio, or custom range corresponding to 4–20 mA. *Figure 5* below illustrates some common system configuration options.

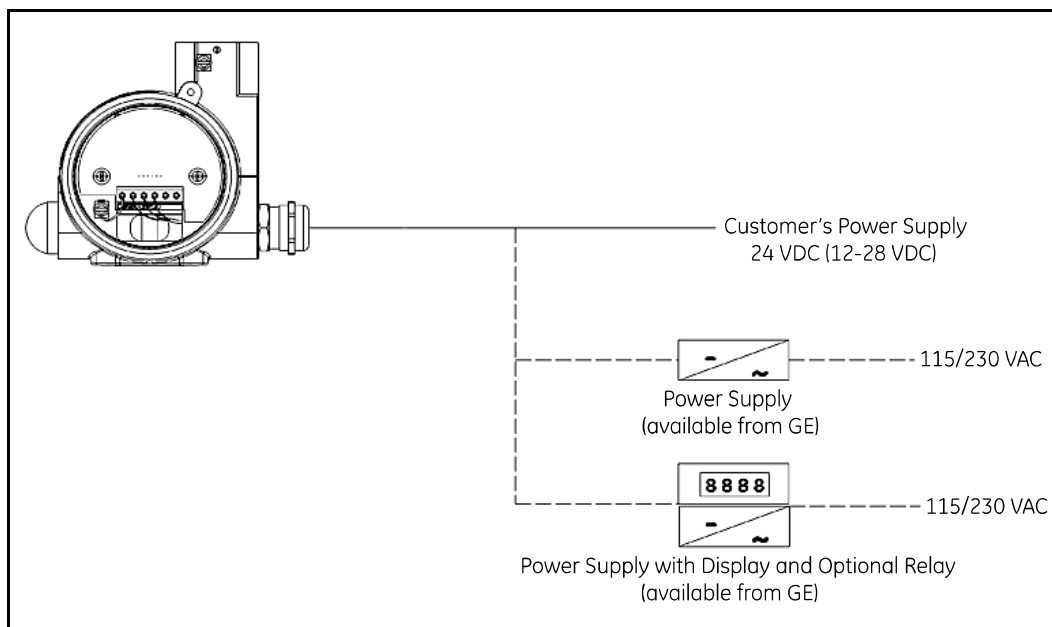

Figure 5: System Configuration Options

2.2.2 Normal Environments

A standard two-wire, stranded cable can be used in a normal environment to interconnect the MMR31 with its loop power source.

2.2.3 Environments with Severe Electrical Noise

When the MMR31 is installed in environments with severe electrical noise, wiring must be done with shielded and grounded cable, as shown in *Figure 6* below. Details of the MMR31 testing and certifications in such environments can be found in Chapter 5, “*Specifications*” on page 29, and the *CE Declaration of Conformity* at the end of this manual.

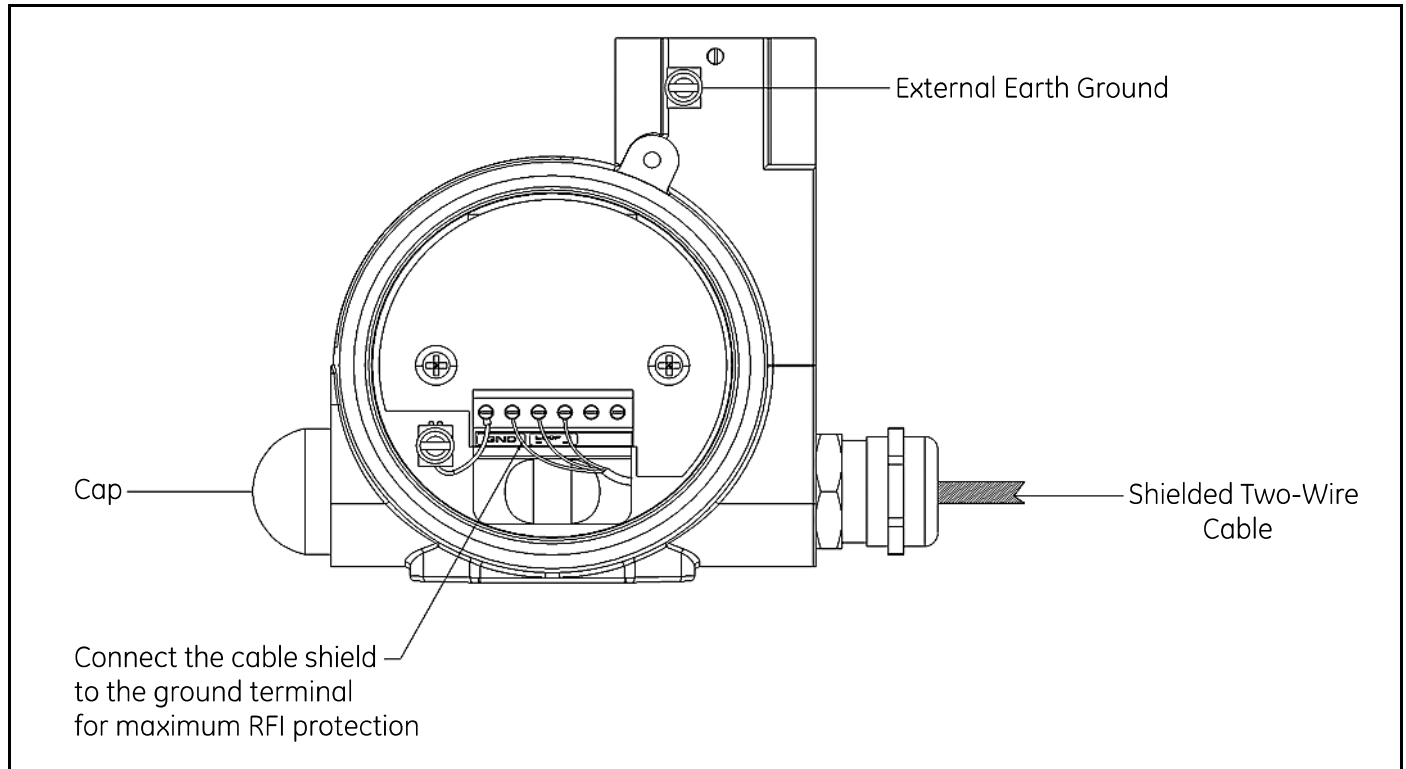

Figure 6: Shielded Cable Wiring Diagram

2.2.4 General Wiring Instructions

To wire the MMR31, refer to *Figure 7* below and complete the following steps:

1. Unscrew the cap on the terminal side of the unit.
2. Loosen the cable gland located on the side of the unit.
3. Feed the cable through the conduit opening.

Note: Use a standard signal cable size.

4. Retighten the metal cable gland to meet IP 67 and to relieve any stress on the wire.
5. Connect the wires to the MMR31 terminals as shown in *Figure 7* below.
6. Verify that a voltage between 12 and 28 VDC is present across the terminals marked + and –.

Note: This is the voltage that is actually measured across the MMR31 terminals. It is not necessarily exactly the same as the power supply voltage, due to voltage loss in the wires, displays, indicators, etc.

7. To meet EMI/RFI immunity requirements, a two-wire shielded cable with a common foil shield layer is used to power the MMR31. To clamp the shield foil in the metal cable gland, remove 3 in. (75 mm) of the insulation and fold back the foil. The ground wire must be connected to the internal grounding screw.

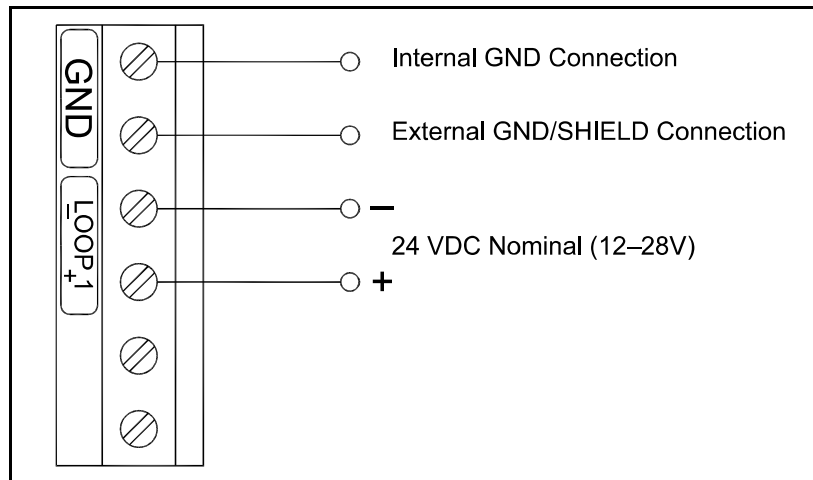

Figure 7: Electrical Connections - One Current Loop

2.3 Wiring Configurations with Two Current Loops



CAUTION! The MMR31 system contains electronic components that are susceptible to damage by static electricity. Proper handling procedures must be observed during the removal, installation, or other handling of internal circuit boards.

2.3.1 General Guidelines

The maximum loop resistance is an important parameter for selection of the supply voltage, because each device connected to the loop causes a voltage drop. For instance, using a loop-powered display with an input impedance of 50 ohms will cause a voltage drop of 1 VDC at 20 mA, per Ohm's law ($V = R \times I = 50 \times 0.020 = 1$). Similarly, connecting the loop to a Programmable Logic Controller (PLC) will cause a voltage drop across its input.

When designing your loop, add up all voltage drops across the devices connected to the loop and then add 12 V. This sum is the minimum supply voltage required for the circuit. To ensure reliable operation, it is recommended that a 20% safety factor be added to the calculated voltage requirement.

IMPORTANT: *The voltage across the + and - terminals of the MMR31 should not fall below 12 VDC.*

If an external display is used, configure it to the proper range: 0-100% RH, 5 to 185°F (–15 to +85°C) dew point, 1 to 350 g/m³ absolute humidity, 1 to 830 g/kg mixing ratio, or custom range corresponding to 4–20 mA. *Figure 8* below illustrates a typical configuration.

The same general specifications apply to the second current loop. However, the range for the second current loop is always 5 to 185°F (–15 to +85°C), corresponding to temperature, unless an optional display/user interface is used for a custom range.

IMPORTANT: *Be sure that the two current loops are connected independently. DO NOT install a jumper at the MMR31 + and - terminals to power both current loops from a single power supply.*

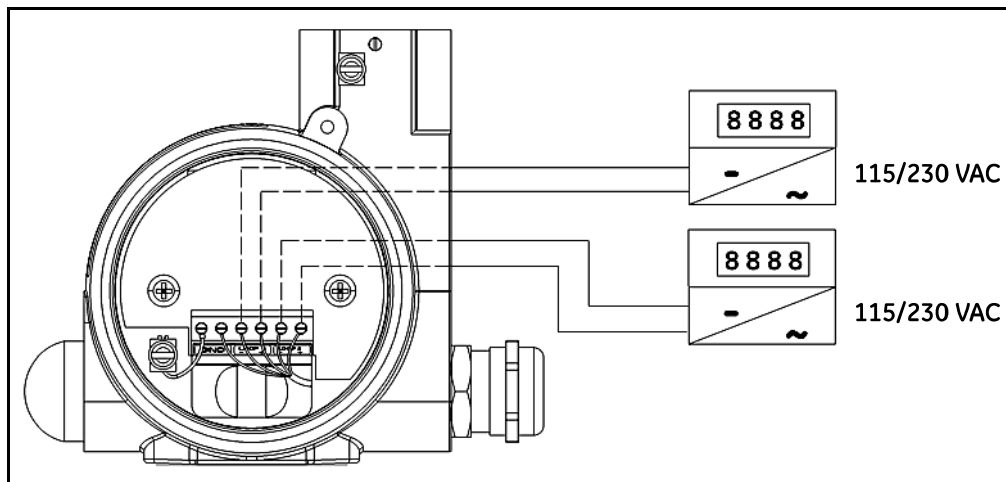

Figure 8: System Configuration with Display and Power Supply

2.3.2 Normal Environments

A standard two-wire, stranded cable can be used in a normal environment to interconnect the MMR31 with its loop power sources.

2.3.3 Environments with Severe Electrical Noise

When the MMR31 is installed in environments with severe electrical noise, wiring must be done with shielded and grounded cable, as shown in *Figure 9* below. Details of the MMR31 testing and certifications in such environments can be found in Chapter 5, “*Specifications*” on page 29, and the *CE Declaration of Conformity* at the end of this manual.

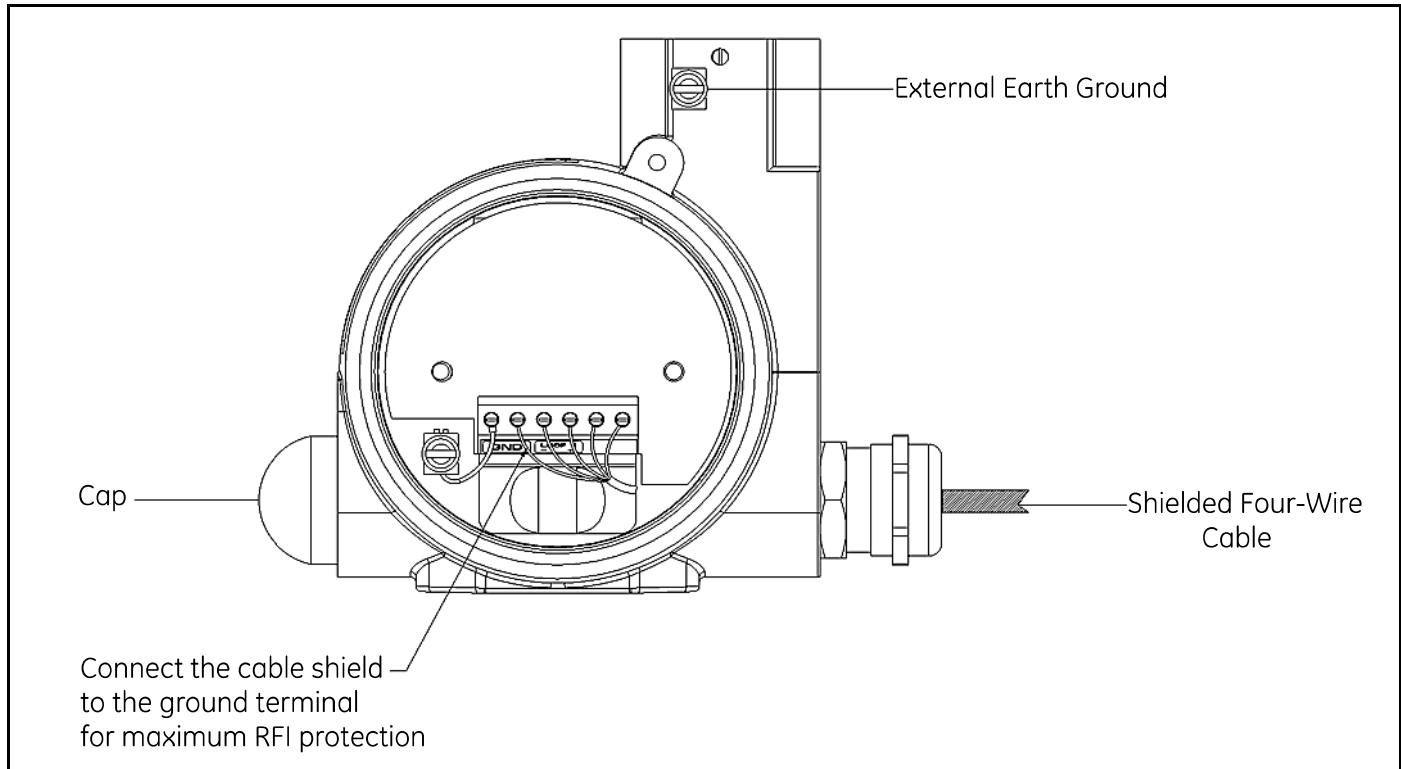

Figure 9: Shielded Cable Wiring Diagram

2.3.4 General Wiring Instructions

To wire the MMR31, refer to *Figure 10* below and complete the following steps:

1. Unscrew the cap on the terminal side of the unit.
2. Loosen the cable gland located on the side of the unit.
3. Feed the cable through the conduit opening.

Note: Use a standard signal cable size.

4. Retighten the metal cable gland to meet IP 67 and to relieve any stress on the wire.
5. Connect the wires to the MMR31 terminals as shown in *Figure 10* below.
6. Verify that a voltage between 12 and 28 VDC is present across the terminals marked + and –.

Note: This is the voltage that is actually measured across the MMR31 terminals. It is not necessarily exactly the same as the power supply voltage, due to voltage loss in the wires, displays, indicators, etc.

7. To meet EMI/RFI immunity requirements, a four-wire shielded cable with a common foil shield layer is used to power the MMR31. To clamp the shield foil in the metal cable gland, remove 3 in. (75 mm) of the insulation and fold back the foil. The ground wire must be connected to the internal grounding screw.

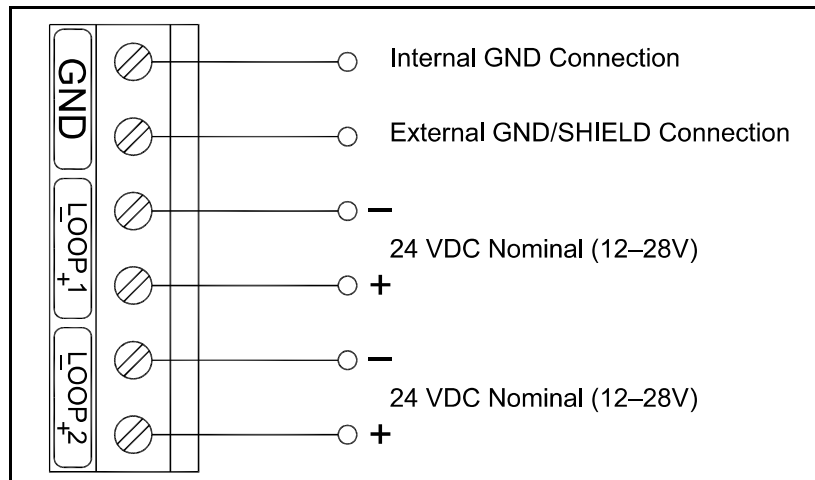

Figure 10: Electrical Connections - Two Current Loops

2.4 Selecting the Units of Measure

Unless otherwise specified, the MMR31 is shipped with a standard range of 0-100% relative humidity. To select other units of measure, complete the following steps:

1. Remove the cover opposite to the wiring compartment to access *Switch S3* (see *Figure 11* below).

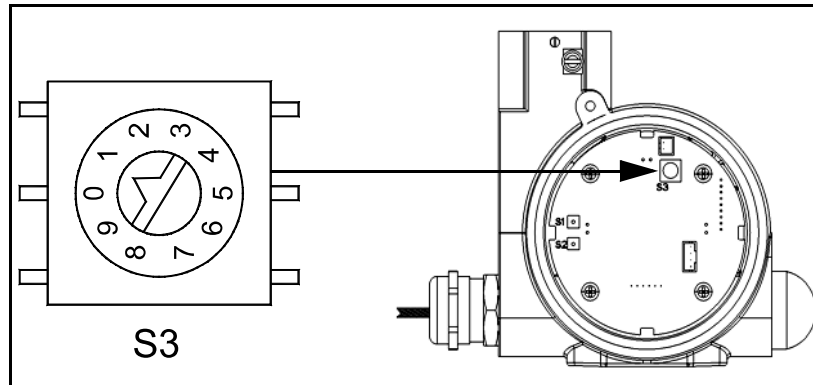

Figure 11: Switch S3 Location

2. Using a 2-mm screwdriver, turn *Switch S3* to the position corresponding to your desired units of measure. The available options are listed in *Table 1* below:

Table 1: Units of Measure Options

Switch S3 Position	Mode	Range
0	% RH	0 to 100%
1	Dew point	5 to 185°F (-15 to +85°C)
2	Mixing Ratio	1 to 830 g/kg
3	Absolute Humidity	1 to 350 g/m ³
8	Dew point	Custom
9	% RH Calibration with Salt Bottles (75.4 and 11.3%)	0 to 100%

For example, if *Switch S3* is set to *position 1* to select *dew point mode*, the current output represents a 5 to 185°F (-15 to +85°C) dew point temperature range. Any attached indicators need to be rescaled from their original RH (0–100%) range to the new dew point range.

Chapter 3. Calibration and Troubleshooting

3.1 Calibration Using Two Saturated Salt Solutions



CAUTION! Be certain that the system is depressurized. The MMR31 must be removed from the process prior to calibration.

Utilizing saturated salt solutions is one of many methods available to calibrate a relative humidity sensor. Depending on the salt used (lithium chloride and sodium chloride are recommended), a defined relative humidity will occur above the solution at a given temperature. The accuracy of this method is dependent on the stability of the temperature during the calibration. It is important that the temperature of the salt solution and the temperature of the enclosed atmosphere above the solution are the same.

Note: *To achieve optimum results, it is recommended that calibration be performed at 77.5°F (25.3°C) because the temperature compensation correction is zero at this temperature. Deviating from this value by ±9°F (±5°C) will introduce an error of approximately 1%.*

To complete the following procedure, you will need:

- Two salt calibration bottles (11.3% and 75.4%) of the type available from GE for RH field calibration
- Screwdriver, 2-mm wide
- An ammeter or current display with a range of 0-100 mA

3.2 Calibration Steps

Note: *The following steps describe the use of an ammeter for calibration. If the current loop already contains a current display to indicate the moisture values, an additional ammeter is unnecessary.*

1. Remove both covers from the MMR31 enclosure.
2. Disconnect the negative (–) lead of moisture loop 1.
3. Connect the ammeter into the loop as shown in *Figure 12* below.
4. Choose the 20 mA range on the ammeter.

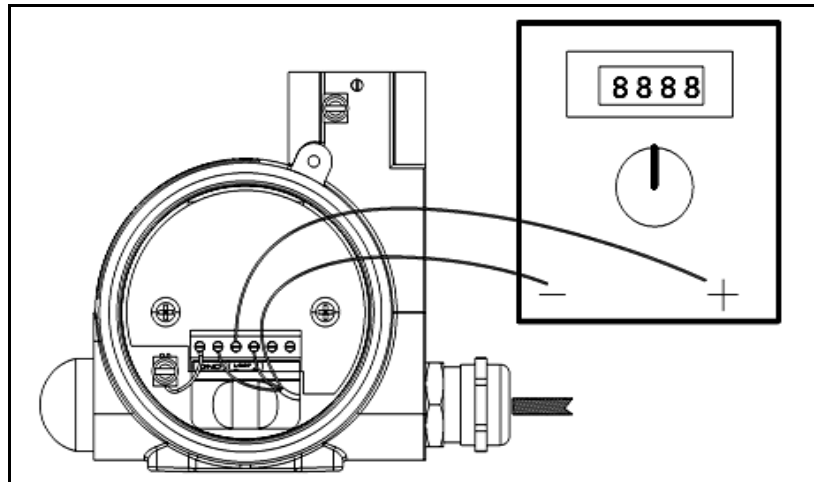

Figure 12: Ammeter Connections

Two buttons (**S1** and **S2**) and one rotary switch (**S3**) are located on the circuit board. Button **S1** is used to calibrate the 11.3% RH value with a lithium chloride salt solution, while button **S2** is used to calibrate the 75.4% RH value with a sodium chloride salt solution. Switch **S3** is set to position 9 for calibration mode (see *Figure 13* below).

Note: *If the unit is equipped with a display, the buttons on the display are used instead (see Chapter 4, “Optional Display/User Interface” on page 19 for detailed instructions).*

5. Use a 2-mm screwdriver to turn Switch 3 to position 9.

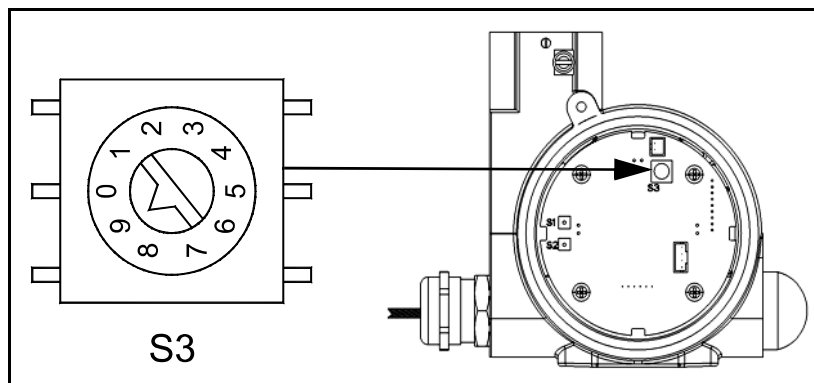

Figure 13: Setting Switch S3

3.2.1 Calibrating the Low RH Reading

Note: *For the low RH reading, a saturated salt solution of lithium chloride is used to provide an 11.3% relative humidity reference.*

1. Insert the probe into the calibration bottle, almost to the bottom.
2. Observe the ammeter. The reading will change toward 5.8 mA (or 11.3% on a display) after insertion of the probe.

Note: *For successful calibration, it is important that the temperature in the salt solution and in the enclosed atmosphere above the solution reach equilibrium at the same value. After waiting for approximately two hours, the ammeter reading should stabilize.*

3. If the meter reading is stable at 5.80 mA (or 11.3% on a display), press **SI** for at least one second. This assigns the 11.3% RH value. If only the low RH calibration will be performed, return *Switch S3* to position 0 (see *Figure 13 on page 16*). Otherwise, continue to the next section to calibrate the high RH reading.

3.2.2 Calibrating the High RH Reading

Note: *For the high RH reading, a saturated salt solution of sodium chloride is used to provide an 75.4% relative humidity reference.*

1. Insert the probe into the calibration bottle, almost to the bottom.
2. Observe the ammeter. The reading will change toward 16 mA (or 75.4% on a display) after insertion of the probe.

Note: *For successful calibration, it is important that the temperature in the salt solution and in the enclosed atmosphere above the solution reach equilibrium at the same value. After waiting for approximately two hours, the ammeter reading should stabilize.*

3. If the meter reading is stable at 16 mA (or 75.4% on a display), press **S2** for at least one second. This assigns the 75.4% RH value. Return *Switch S3* to position 0 (see *Figure 13 on page 16*).
4. After successful calibration, remove the ammeter, reconnect the negative (-) lead and reinstall the cover.

Note: *During calibration, if the wrong key is pressed, the value will not be accepted due to a plausibility check*

3.3 Troubleshooting

3.3.1 Loop Current is Out of Range

3.3.1a Unit of Measure is RH

Note: *0% and 100% relative humidity are absolute limits. However, a defective sensor or a malfunction of the sensor electronics could generate sensor signal values which are outside the 0-100% range. If the sensor signal value is above 100% or below 0%, the current will go to the fault current specified on the order or in the matrix field VH 07.*

Solution: Expose the sensor to ambient air which normally has a relative humidity between 10% and 90%. If the current returns the 4–20 mA range, check the sensor calibration (see “*Calibration Steps*” on page 16). However, if the current remains in error mode contact GE for assistance.

3.3.1b Unit of Measure is Dew Point

Solution 1: The process dew point is out of range. If the dew point is above 185°F (85°C), the current will go to the fault current specified on the order or in the matrix field VH 07. Apply dry air for a few minutes. If the current remains in error mode contact GE for assistance.

Solution 2: If the dew point is below 5°F (–15°C), the current will go to the fault current specified on the order or in the matrix field VH 07. Move the sensor into a wetter environment for a few minutes. If the dew point doesn't increase, the cause may be a defective sensor assembly or an electronics malfunction. Contact GE for assistance.

Note: *The same approach is valid for the other available units of measure and for the second loop (temperature).*

3.3.2 No Loop Current

Solution: Check the voltage and polarity across the positive (+) and negative (-) terminals of the MMR31 with a DC voltmeter. If the voltage is within the 12-28 VDC range, contact GE for assistance.

3.3.3 Slow Response Time

Solution: Remove the protective filter cap by turning it counter-clockwise, and clean it with air flow or a solvent. If the sensor filter is contaminated, clean it with hot water using a brush.

3.3.4 Frozen Output Current

Solution: Check *Switch S3*, which should be in position 0, 1, 2, 3, 8 or 9.

Chapter 4. Optional Display/User Interface

4.1 Accessing the Programming Buttons

If your MMR31 is equipped with an optional display/user interface, follow the procedure below to access the programming buttons.

4.1.1 Removing the Display

To remove the display/user interface, refer to *Figure 14* below and complete the following steps:

1. Unscrew and remove the protective cover from the top of the MMR31, exposing the display module. The four buttons **V**, **H**, **+** and **-** are now accessible.
2. The display unit snaps onto the printed circuit board and rests on four posts. When removing the display, push one post to the outside, using a small screwdriver, and pull the display out.
3. Then, unplug the display cable.

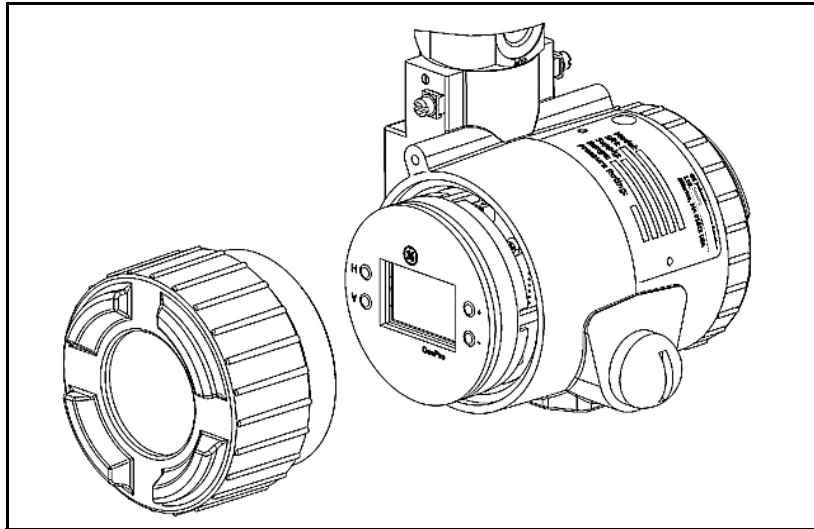

Figure 14: MMR31 with Display

4.2 Programming the Matrix

In the MMR31 with the display option, a matrix-style input is used for programming the units of measure, measuring range, error status of output, and output adjustment.

Note: *For users of other GE Sensing equipment, this matrix format may be familiar. However, this section describes the features and usage of the various matrix locations only as they apply to the MMR31.*

The MMR31 display (see *Figure 15* below) continuously shows the current matrix location using the vertical (**V**) and horizontal (**H**) coordinates to designate the row and column, respectively. The bar graph represents the output current in an analog fashion.

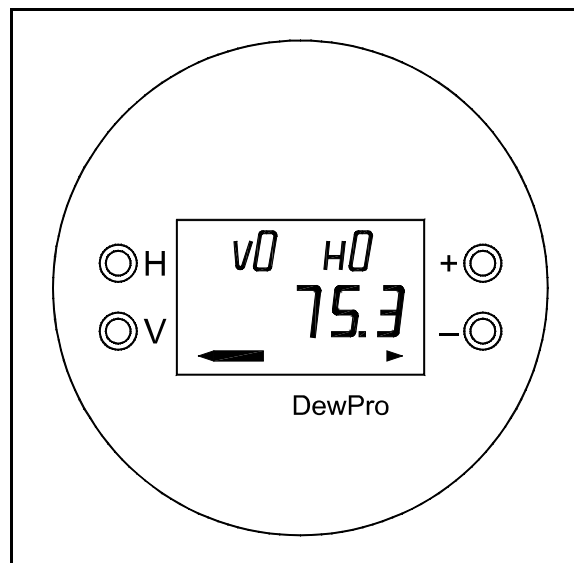

Figure 15: MMR31 Display

The **V** and **H** buttons are used to move to another row or column in the matrix (see *Table 3 on page 21*). For example, to select location **VH 45** from a starting location of **VH 00**, press **V** four times and then press **H** five times to arrive at **VH 45** (i.e., row 4 and column 5).

At any matrix location where the matrix value may be changed by the user, the digit to be changed is flashing, and the desired value is programmed using the **+** and **-** buttons. For example, at matrix location **VH 01**, the desired moisture units are selected by choosing from the matrix values listed in *Table 2* below.

Table 2: Moisture Unit Options

Matrix	Moisture Unit
0	% RH
1	Td °C
2	Td °F
3	g/m ³
4	g/kg

Table 3: Matrix Options

MMR31	Row	H0	H1	H2	H3	H4	H5	H6	H7	H8	H9
Moisture Unit	V0	Display Moisture Value	Select Moisture Unit (see Table 2)							Loop 1 Raw Reading	
Loop Range	V1	% RH 4 mA	% RH 20 mA	Dewpoint °C 4 mA	Dewpoint °C 20 mA	Dewpoint °F 4 mA	Dewpoint °F 20 mA	g/m ³ 4 mA	g/m ³ 20 mA	g/kg 4 mA	g/kg 20 mA
	V2										
Constant; Loop Hardware Calibration	V3	Pressure Constant in mmHg								Loop 1 D/A Calibration Low	Loop 1 D/A Calibration High
Temp. Unit; Loop 1 Hardware Calibration	V4	Display Temp. Value	Select Unit of Temp. 0 = °C; 1 = °F				Temp. 4 mA	Temp. 20 mA	Loop 2 at Fault 0 = -10% 1 = 110% 2 = Hold	Loop 2 Raw Reading	
	V5										
RH Calibration	V6								Enable Calibration; enter digit other than 0	Enter Low RH (%)	Enter High RH (%)
Loop 2 Hardware Calibration	V7									Loop 2 D/A Calibration Low	Loop 2 D/A Calibration High
Access Key	V8										Input Locking 50 = Unlock
Misc. Setup	V9	Display Present Error	Previous Error	Unit ID	Software Version		Reset to Defaults 50 = Reset				System Reset 50 = Reset

4.3 Matrix Buttons - Special Functions

4.3.1 Reset to “Normal” Display

Pressing the **V** and **H** buttons simultaneously returns the user to **VH 00** (normal display).

4.3.2 Display Only

Eight (8) matrix locations are for display only and may not be changed by the user (see *Table 3 on page 21*). The “display only” fields are as follows:

Table 4: “Display Only” Matrix Locations

Location	Display Description
VH 00	Normal display (in dewpoint, % RH, mixing ratio or absolute humidity as selected in VH 01)
VH 08	Indicates digitized moisture signal
VH 40	Displays temperature
VH 48	Indicates digitized temperature signal
VH 90	During a system alarm, displays the error code for the fault encountered
VH 91	During normal operation, displays the previous error code for reference
VH 92	Displays the factory issued identification number
VH 93	Displays the factory-issued reference number designating the device type and software version

4.3.3 Default Values

A default value is assigned to each programmable matrix field. These values are loaded after a reset to factory programmed data has been executed (see **VH 95**).

4.4 Matrix Functions

This section describes the functions available to the user through the matrix, grouped by common function areas (see *Table 3 on page 21*). Each function is accessed by moving to its specified location within the matrix.

4.4.1 System Administration Functions

Table 5: System Administration Functions

Function	Location	Description
Locking/ Unlocking the Matrix	VH 89	This location allows the user to lock and unlock the matrix input functions. When the matrix is locked, the V and H keys are still functional but the + and - keys are disabled. This prevents unauthorized modification of any of the user input functions, such as output ranging or units selection. Entering the value 50 in this location unlocks the matrix. Any other value locks the matrix. (Default: 0)
System Reset	VH 99	This location allows the user to reset the system electronics in a manner similar to removing and re-applying power. No system parameter settings are modified. Entering the value 50 in this location initiates the reset, and after approximately five (5) seconds the reset is executed. After the reset, normal operation is resumed at location VH 00 .
Transmitter Identification	VH 92	This location displays the identification number of the transmitter. The display should read 200 .
Software Version	VH93	This location displays the version number of the instrument software.
Two-Point Calibration Using Any Low and High RH Value	VH67	In this location, the calibration using VH 68 and VH 69 is enabled by entering any digit other than 0 . Follow the steps described in “ <i>Calibration Steps</i> ” on page 16. Enter 11.3 in VH 68 and 75.4 in VH 69 . If a different moisture source is being used (e.g., a variable moisture generator or other saturated salt solutions), any low value can be entered in VH 68 and any high value in VH 69 . Be sure the high and low values differ by at least 20%. The hardware buttons on the printed circuit board are still active, performing an 11.3 and 75.4 calibration. As described in “ <i>Calibration Steps</i> ” on page 16, location VH 68 would reset to 11.3 and location VH 69 to 75.4 .
Low RH Point Calibration	VH68	Enter the low RH value in % when the reading is stable. VH 67 has to have a value other than 0 . Be sure the high and low values differ by at least 20%.
High RH Point Calibration	VH 69	Enter the high RH value in % when reading is stable. VH 67 has to have a value other than 0 . Be sure the high and low values differ by at least 20%.

4.4.2 Moisture Measurement Functions

Table 6: Moisture Measurement Functions

Function	Location	Description
Display Current Process Value	VH 00	This location displays the current process humidity value measured by the instrument. The units of measure for the displayed value (i.e., % RH, dew point or units selected under VH 01) is selected in position VH 01 . The bar graph beneath the numeric display represents the position of the current value within the range programmed for the selected units of measure.
Select Units of Measure for Display	VH 01	This location selects the units of measure to be used for the humidity value display. The available options are: 0 = % relative humidity (Default) 1 = °C dew point 2 = °F dew point 3 = grams/m ³ 4 = grams/kg dry air.
Loop #1 at Fault	VH 07	This location specifies the state of current output #1, corresponding to the detection of a fault with either the humidity sensor or the measurement circuitry. The available options are: 0 = -10% (3.6 mA) 1 = 110% (22 mA) (Default) 2 = Hold at previous level
Display the Moisture Frequency	VH 08	When this location is selected, the A/D counts from the moisture measurement circuit are displayed.

4.4.3 4-20 mA Output Range Functions

Table 7: Setting Output Ranges for Humidity 4-20mA Output

Function	Location	Description
Range of Humidity Values	VH 10	% RH 4mA (Default: 0)
	VH 11	% RH 20mA (Default: 100)
	VH 12	°C dew point 4mA (Default: -15)
	VH13	°C dew point 20mA (Default: +85)
	VH 14	°F dew point 4mA (Default: 5)
	VH 15	°F dew point 20mA (Default: 185)
	VH 16	grams/m ³ 4mA (Default: 1)
	VH 17	grams/m ³ 20mA (Default: 350)
	VH 18	grams/kg dry air 4mA (Default: 1)
VH 19	grams/kg dry air 20mA (Default: 830)	
Pressure Constant Adjustment	VH 30	This location allows the user to enter a value for the process pressure. The value is entered in mmHg. This value is used only for the calculation of the unit grams/kg dry air. (Default: 760)
Calibrating the Current Output	VH 38	<p>These locations are used to calibrate the 4 mA and 20 mA hardware settings of the humidity output current loop. This output comes calibrated from the factory and should not normally need adjustment. To check the setting, connect an ammeter in series with the negative (-) power terminal for loop #1 (see <i>“Wiring Configurations with One Current Loop”</i> on page 8). Move to matrix location VH 38. The output will automatically change to the 4 mA setting. Adjust as necessary using the + and - keys. Move to location VH 39. The output will automatically change to the 20 mA setting. Adjust as necessary. Move to any other matrix location to return the output to normal operation.</p> <p>If the matrix input is locked (VH 89), the calibration values are displayed, but the current output is unaffected.</p>
	VH 39	

4.4.4 Temperature Measurement Functions

Table 8: Temperature Measurement Functions

Function	Location	Description
Displaying the Measured Temperature	VH 40	Selecting this location displays the present process temperature. The unit of measure (°F/°C) is the unit selected in location VH41 (see below).
Selecting the Temperature Unit	VH 41	This allows the user to select either °F or °C as the temperature measurement unit to be displayed in location VH 40 . Setting this location to 0 selects °C, and setting to 1 selects °F. (Default: 0)
Setting the Temperature Output Range	VH 45 VH 46	These locations specify the range of temperatures corresponding to the 4–20 mA range of current output #2. The range of values for both locations is from -15 and +85 . The output range is always specified in °C, regardless of the display units selected.
Loop #2 at Fault	VH 47	This location specifies the condition for current output #2 when a fault is detected in the temperature measurement circuitry. The available options are: 0 = -10% (3.6 mA) 1 = 110% (22 mA) (Default) 2 = Hold at previous level
Calibrating the Current Output	VH 78 VH 79	These locations are used to calibrate the 4 mA and 20 mA hardware settings of the temperature output current loop. This output comes calibrated from the factory and should not normally need adjustment. To check the setting, connect an ammeter in series with the negative (-) power terminal for loop #2. Move to matrix location VH 78 . The output will automatically change to the 4 mA setting. Adjust as necessary using the + and - keys. Move to location VH 79 . The output will automatically change to the 20 mA setting. Again, adjust as necessary. Move to any other matrix location to return the output to normal operation. If the matrix input is locked (VH 89), the calibration values are displayed, but the current output is unaffected.

4.4.5 Error Codes

During normal MMR31 operation, it is possible for the temperature channel to be in error, while the RH channel still reads correctly. It is also possible for the RH channel to be in error, while the temperature channel still reads correctly. If a moisture unit that depends on both the RH and temperature values (e.g., dewpoint) is selected, the error conditions for both $RH < 0\%$ and $RH > 100\%$ will be set. MMR31 errors are indicated in the matrix (see *Table 3 on page 21*), as shown in *Table 9* below.

Table 9: Error Code Display

Function	Location	Description
Display the Present Error Code	VH 90	This location displays a number associated with an error code. If no error condition exists, the location displays 0 . Use the instructions in this section to properly interpret the error code.

The procedure for interpreting the **VH 90** error codes involves the conversion of numbers from decimal format into binary format. To perform these conversions, refer to *Table 10* below.

Table 10: Decimal to Binary Conversions

Decimal Value	Binary Equivalent
0	0000
1	0001
2	0010
3	0011
4	0100
5	0101
6	0110
7	0111
8	1000
9	1001
10	1010
11	1011
12	1100
13	1101
14	1110
15	1111

4.4.5 Error Codes (cont.)

When a value other than **0** is displayed in matrix location **VH 90**, complete the following steps to determine the cause of the error (a value of **39** is used as an example in the steps below):

1. Divide the error code displayed in matrix location **VH 90** by 16.
[**Example:** $39/16 = 2.4375$]
2. Determine the *temperature channel* error code by converting the integer portion of the result in step 1 to binary format (see *Table 10 on page 27*).
[**Example:** integer portion of $2.4375 = 2 = 0010$ binary]
3. Determine the *moisture channel* error code by multiplying the decimal portion of the result in step 1 by 16 and then converting the result to binary format (see *Table 10 on page 27*).
[**Example:** $16 \times$ decimal portion of $2.4375 = 16 \times 0.4375 = 7 = 0111$ binary]
4. Each **"1"** in the binary values calculated in steps 2 and 3 above corresponds to a particular MMR31 error. Identify these errors by referring to *Table 11* below.
[**Example:** The **"1"** in the third position of the *temperature channel* error code (see step 2 above) means that the temperature reading is **> 85°C**. The **"1"** in the second, third and fourth positions of the *moisture channel* error code (see step 3 above) means that Output 1 is **< 4 mA** and that the moisture unit selected depends on the temperature.

Table 11: Error Code Identifications

Temperature Channel 4-Digit Code				Moisture Channel 4-Digit Code			
X	X	X	X	X	X	X*	X*
CH2 Output > 20 mA	CH2 Output < 4 mA	Temp. > +85°C	Temp. < -15°C	CH1 Output > 20 mA	CH1 Output < 4 mA	RH > 100%	RH < 0%
* If both of these positions are set to "1" , the selected moisture unit depends on the temperature.							

To further illustrate the process, let's try one more example. If the **VH 90** matrix location displays an error code of **1**:

Step 1: $1/16 = 0.0625$

Step 2: *temperature channel* error code = integer portion of $0.0625 = 0 = 0000$ binary

Step 3: *moisture channel* error code = $16 \times$ decimal portion of $0.0625 = 16 \times 0.0625 = 1 = 0001$ binary

Step 4: There are no temperature errors. The moisture error indicates that $RH < 0\%$

Chapter 5. Specifications

5.1 Technical Specifications

Sensing Element:

Silicon-based polymer, capacitance principle, IC electronics

RH Range:

0 to 100%

RH Accuracy:

±2% in the range of 0% to 90% at 25°C

±3% in the range of 90% to 100% at 25°C

Dew Point Range:

5 to 185°F (-15 to +85°C)

Dew Point Accuracy:

±1.8°F (±1°C) above 32°F (0°C), T <86°F (<30°C) and RH >30%

Operating Temperature Range:

5 to 185°F (-15 to +85°C); temperature signal available with second loop

Operating Temperature of Electronics:

-40 to +185°F (-40 to +85°C)

Temperature Accuracy:

±0.9°F (±0.5°C)

Absolute Humidity Range:

1 to 350 g/m³

Mixing Ratio Range:

1 to 830 g/kg

Maximum Operating Pressure:

250 psig (17 bar)

Outputs:

Loop current 4 to 20 mA, 16 µA resolution, optional output for temperature

5.1 Technical Specifications (cont.)

Electronics:

Microcontroller operation

EM I/RFI Protection:

See “*EMI/RFI Protection*” on page 31

Moisture Units:

% RH, dew point temperature in °F or °C, absolute humidity in g/m³, or mixing ratio in g/kg, hardware selectable

Power Supply:

24 VDC nominal, 12 to 28 VDC range

Protection:

Type 4X (IP67)

Probe Tube:

316 stainless steel, 1/2 in. (12.7 mm) diameter, insertion length 3.0 in. (75 mm) to 5.9 in. (150 mm), adjustable

Typical Probe Mounting:

1/2 in. (12.7 mm) tube x 1/2 in. (12.7 mm) NPT-M or

1/2 in. (12.7 mm) tube x G 1/2 compression fitting.

Weight:

3.3 lb (1.5 kg)

5.2 Optional Onboard Display with User Interface

The optional onboard display with user interface uses a matrix configurator for:

- Range changes
- Unit of measure selection
- Current loop adjustment
- Error diagnostics
- Current value selection for fault conditions

5.3 EMI/RFI Protection

IEC 61000-4, Performance Criterion A test results for the MMR31 were as follows:

- Conducted Emission Test as per CISPR 11 Class A, 2004
- Radiated Emission Test as per CISPR 11 Class A, 2004
- Radiated Susceptibility Test as per IEC 61000-4-3, 2002
- Electrostatic Discharge Test as per IEC 61000-4-2, 2001
- Electrical Fast Transient Test as per IEC 61000-4-4, 2004
- High Energy Surge Immunity Test as per IEC 61000-4-5, 2001
- Power Frequency Magnetic Field Test as per IEC 61000-4-8, 2001

5.4 EMC Compliance

The MMR31 meets the EMC requirements of IEC 61326 for equipment used in industrial locations

5.5 Available Accessories

The following optional accessories are available for the MMR31:

- Single power supply
- Panel mount display, power supply, no relays
- Panel mount display, power supply, two alarms
- Panel mount display, power supply, two alarms, 4-20 mA repeating output

Note: *For other requirements, contact GE for assistance.*

[no content intended for this page]

A		Environmental Compliance	iv
Accessories, Available	31	Error Codes	
Ammeter, Calibration	15	Examples	28
B		Interpreting	28
Binary Conversion Table	27	Matrix Location	27
Bracket, Mounting with	7	Examples, Error Codes	28
Buttons		F	
Calibration	16	Flange, Mounting with	6
Matrix Programming	20	Functions	
Programming, Accessing	19	4-20 mA Output Range	25
Special Functions	22	Matrix	22
C		Moisture Measurement	24
Cable, Shielded	9	System Administration	23
Calibration		Temperature Measurement	26
Ammeter	15	G	
Buttons	16	Guidelines, Wiring	8, 11
High RH Reading	17	I	
Low RH Reading	17	Information Paragraphs	iii
NIST Reference	4	Installation	
Steps Required	16	Compression Fitting	6
Switch	16	Flange	6
Using Saturated Salt Solutions	15	In Pipe or Container	6
Components, Transmitter	3	In Room	7
Compression Fitting, Mounting with	6	Mounting Dimensions	5
Conversion, Decimal to Binary Table	27	With Bracket	7
D		L	
Date of Publication	i	Label, Product	1
Default Values, Matrix	22	Loop	
Dimensions, Mounting	5	Current Out of Range	18
Display		First, Description	4
Matrix Locations	22	Frozen Output Current	18
Removing	19	No Current	18
Display/User Interface		One, Electrical Connections	10
Programming Buttons	20	Second, Description	4
Specifications	30	Two, Electrical Connections	13
Document Number	i	Wiring	8, 11
E			
Electrical Connections			
One Current Loop	10		
Two Current Loops	13		
Electrical Noise	9, 12		
EMC Compliance	31		
EMI/RFI Protection	31		

M	S
Matrix	Safety
"Display Only" Locations 22	Auxiliary Equipment iii
4-20 mA Output Range Functions 25	General Issues iii
Default Values 22	Personal Equipment iv
Error Codes 27	Salt Solutions, Saturated for Calibration 15
Functions 22	Sensor, Description 4
Moisture Measurement Functions 24	Shielded Cable 9
Programming 20	Shipping Damage 1
System Administration Functions 23	Special Functions, Buttons 22
Table of Options 21	Specifications
Temperature Measurement Functions 26	Display/User Interface 30
Model Number 1, 2	Power Supply 30
Moisture Units, List of Options 20	Technical 29
Mounting Dimensions 5	Switch, Calibration 16
N	T
NIST, Calibration Reference 4	Technical Specifications 29
Noise, Electrical 9, 12	Terminals, Wiring 10, 13
Normal Environments, Wiring 9, 12	Theory of Operation 4
	Troubleshooting 18
O	Frozen Output Current 18
Operation, Theory 4	Loop Current Out of Range 18
Options, Available 31	No Loop Current 18
	Slow Response Time 18
P	
Pipe, Mounting in 6	U
Power Supply, Specifications 30	Units of Measure
Product Label 1	Selecting 14
Programming	Table of Values 14
Buttons 20	Unpacking 1
Matrix 20	
Programming Buttons, Accessing 19	V
	Version Descriptions 3
R	W
Removing the Display 19	Warranty 35
Response Time, Slow 18	WEEE Directive iv
Return Policy 35	Weight, Transmitter 30
RH	Wiring
Calibrating High Reading 17	Electrical Noise 9, 12
Calibrating Low Reading 17	General Guidelines 8, 11
Room, Mounting in 7	General Instructions 10, 13
	Normal Environments 9, 12
	One Current Loop 8
	Terminals 10, 13
	Two Current Loops 11

Warranty

Each instrument manufactured by GE Sensing is warranted to be free from defects in material and workmanship. Liability under this warranty is limited to restoring the instrument to normal operation or replacing the instrument, at the sole discretion of GE Sensing. Fuses and batteries are specifically excluded from any liability. This warranty is effective from the date of delivery to the original purchaser. If GE Sensing determines that the equipment was defective, the warranty period is:

- One year from delivery for electronic or mechanical failures
- One year from delivery for sensor shelf life

If GE Sensing determines that the equipment was damaged by misuse, improper installation, the use of unauthorized replacement parts, or operating conditions outside the guidelines specified by GE Sensing, the repairs are not covered under this warranty.

The warranties set forth herein are exclusive and are in lieu of all other warranties whether statutory, express or implied (including warranties or merchantability and fitness for a particular purpose, and warranties arising from course of dealing or usage or trade).

Return Policy

If a GE Sensing instrument malfunctions within the warranty period, the following procedure must be completed:

1. Notify GE Sensing, giving full details of the problem, and provide the model number and serial number of the instrument. If the nature of the problem indicates the need for factory service, GE Sensing will issue a RETURN AUTHORIZATION NUMBER (RAN), and shipping instructions for the return of the instrument to a service center will be provided.
2. If GE Sensing instructs you to send your instrument to a service center, it must be shipped prepaid to the authorized repair station indicated in the shipping instructions.
3. Upon receipt, GE Sensing will evaluate the instrument to determine the cause of the malfunction.

Then, one of the following courses of action will then be taken:

- If the damage is covered under the terms of the warranty, the instrument will be repaired at no cost to the owner and returned.
- If GE Sensing determines that the damage is not covered under the terms of the warranty, or if the warranty has expired, an estimate for the cost of the repairs at standard rates will be provided. Upon receipt of the owner's approval to proceed, the instrument will be repaired and returned.

[no content intended for this page]

We,

GE Sensing
1100 Technology Park Drive
Billerica, MA 01821
USA

declare under our sole responsibility that the

DewPro[®] MMR30 Moisture Transmitter Probe
DewPro[®] MMR31 Moisture Analyzer
DewPro[®] MMY30 and MMY31 Dew Point Transmitters
DewPro[®] MMR101 High-Temperature Moisture Transmitter

to which this declaration relates, are in conformity with the following standards:

- EN 61326-1: 2006, Class A, Group 1, Table 2, Industrial Locations
- EN 61326-2-3: 2006

following the provisions of the 2004/108/EC EMC Directive.

The unit listed above and any ancillary equipment supplied with them do not bear CE marking for the Pressure Equipment Directive, as they are supplied in accordance with Article 3, Section 3 (sound engineering practices and codes of good workmanship) of the Pressure Equipment Directive 97/23/EC for DN<25.

Billerica - November 21, 2014

Issued



Mr. Gary Kozinski
Certification & Standards, Lead Engineer



[no content intended for this page]

Customer Support Centers

U.S.A.

The Boston Center
1100 Technology Park Drive
Billerica, MA 01821
U.S.A.
Tel: 800 833 9438 (toll-free)
978 437 1000
E-mail: sensing@ge.com

Ireland

Sensing House
Shannon Free Zone East
Shannon, County Clare
Ireland
Tel: +353 (0)61 470200
E-mail: gesensingsnnservices@ge.com

An ISO 9001:2008 Certified Company

www.gemeasurement.com/quality-certifications

www.gemeasurement.com

©2015 General Electric Company. All rights reserved.
Technical content subject to change without notice.