

Technical Information

Cerabar PMP23

Process pressure measurement



Pressure transducer with hygienic, flush mount metal sensors

Application

The Cerabar is a pressure transducer for the measurement of absolute and gauge pressure in gases, vapors, liquids and dust for applications with hygienic requirements. The Cerabar can be used internationally thanks to a wide range of approvals and process connections.

Your benefits

- High reproducibility and long-term stability
- Reference accuracy: up to 0.3%
- Customized measuring ranges
 - Turn down up to 5:1
 - Sensor for measuring ranges up to 40 bar (600 psi)
- Housing and process isolating diaphragm made of 316L
- IP69 protection
- Fully-welded process connections
- Suitable for CIP/SIP cleaning
- Optionally available with IO-Link

Table of contents

About this document	4	Environment	19
Document function	4	Ambient temperature range	19
Symbols used	4	Storage temperature range	19
Documentation	5	Climate class	19
Terms and abbreviations	6	Degree of protection	19
Turn down calculation	7	Vibration resistance	19
		Electromagnetic compatibility	19
Function and system design	8	Process	20
Measuring principle - process pressure measurement	8	Process temperature range for devices with metallic process isolating diaphragm	20
Measuring system	8	Pressure specifications	20
Device features	8		
Product design	10	Mechanical construction	21
System integration	10	Design, dimensions	21
		Electrical connection	21
Input	11	Housing	22
Measured variable	11	Process connections with flush mount, metal process isolating diaphragm	23
Measuring range	11	Materials in contact with process	28
		Materials not in contact with process	29
Output	12	Cleaning	29
Output signal	12		
Switching capacity	12	Operability	30
Signal range 4 to 20 mA	12	IO-Link (optional)	30
Load (for 4 to 20 mA devices)	12	Switch output	31
Signal on alarm 4 to 20 mA	13	Plug-on display PHX20 (optional)	31
Dead time, time constant	13	Device Search (IO-Link)	32
Dynamic behavior	13		
Dynamic behavior of switch output	13	Certificates and approvals	33
		CE mark	33
Power supply	14	RoHS	33
Terminal assignment	14	RCM-Tick marking	33
Supply voltage	14	EAC conformity	33
Current consumption and alarm signal	14	Approval	33
Power supply fault	14	Safety Instructions (XA)	33
Electrical connection	15	Suitability for hygienic processes	33
Cable specification	15	Pressure Equipment Directive 2014/68/EU (PED)	34
Residual ripple	15	Manufacturer declarations	34
Influence of power supply	15	Other standards and guidelines	34
Overvoltage protection	15	CRN approval	35
		Calibration unit	35
Performance characteristics of metal process isolating diaphragm	16	Calibration	35
Reference operating conditions	16	Inspection certificates	35
Measuring uncertainty for small absolute pressure measuring ranges	16	Additional approval	36
Influence of the installation position	16		
Resolution	16	Ordering information	36
Reference accuracy	16	Scope of delivery	36
Thermal change of the zero output and the output span	16		
Long-term stability	16	Accessories	37
Switch-on time	16	Weld-in adapter	37
		Process adapter M24	37
Installation	17	Plug-on display PHX20	37
Installation conditions	17	M12 plug connectors	38
Influence of the installation position	17		
Mounting location	17	Supplementary documentation	39
		Field of Activities	39

Technical Information	39
Operating Instructions	39
Brief Operating Instructions	39
Safety Instructions (XA)	39
Registered trademarks	39





About this document

Document function



The document contains all the technical data on the device and provides an overview of the accessories and other products that can be ordered for the device.

Symbols used







Safety symbols

Symbol	Meaning
	DANGER! This symbol alerts you to a dangerous situation. Failure to avoid this situation will result in serious or fatal injury.
	WARNING! This symbol alerts you to a dangerous situation. Failure to avoid this situation can result in serious or fatal injury.
	CAUTION! This symbol alerts you to a dangerous situation. Failure to avoid this situation can result in minor or medium injury.
	NOTICE! This symbol contains information on procedures and other facts which do not result in personal injury.

Electrical symbols

Symbol	Meaning	Symbol	Meaning
	Protective ground connection A terminal which must be connected to ground prior to establishing any other connections.		Ground connection A grounded terminal which, as far as the operator is concerned, is grounded via a grounding system.

Symbols for certain types of information

Symbol	Meaning
	Permitted Procedures, processes or actions that are permitted.
	Forbidden Procedures, processes or actions that are forbidden.
	Tip Indicates additional information.
	Reference to documentation
	Reference to page
	Reference to graphic
	Visual inspection

Symbols in graphics

Symbol	Meaning
1, 2, 3 ...	Item numbers
1. 2. 3. ...	Series of steps
A, B, C, ...	Views

Documentation



The document types listed are available:
 In the Download Area of the Endress+Hauser Internet site: www.endress.com → Download

Brief Operating Instructions (KA): getting the 1st measured value quickly

These instructions contain all the essential information from incoming acceptance to initial commissioning (not for devices with IO-Link).

Operating Instructions (BA): your comprehensive reference

These Operating Instructions contain all the information that is required in various phases of the life cycle of the device: from product identification, incoming acceptance and storage, to mounting, connection, operation and commissioning through to troubleshooting, maintenance and disposal.

Safety Instructions (XA)

Depending on the approval, the following Safety Instructions (XA) are supplied with the device. They are an integral part of the Operating Instructions.

Device	Directive	Documentation	Option ¹⁾
PMP23	ATEX II 1/2G Ex ia IIC T4 Ga/Gb	XA01271P	BA
PMP23	FM IS Cl. I, Div.1 Gr. A-D T4	XA01321P	FA
PMP23	CSA C/US IS Cl. I Div. 1 Gr. A-D	XA01322P	CB
PMP23	EAC Ex ia IIC T4 Ga/Gb	XA01540P	GA
PMP23	IEC Ex ia IIC T4 Ga/Gb	XA01271P	IA
PMP23	NEPSI Ex ia IIC T4	XA01363P	NA
PMP23	JPN Ex ia IIC T4	In preparation	TA

1) Product Configurator, order code for "Approval"



The nameplate indicates the Safety Instructions (XA) that are relevant to the device.

Terms and abbreviations

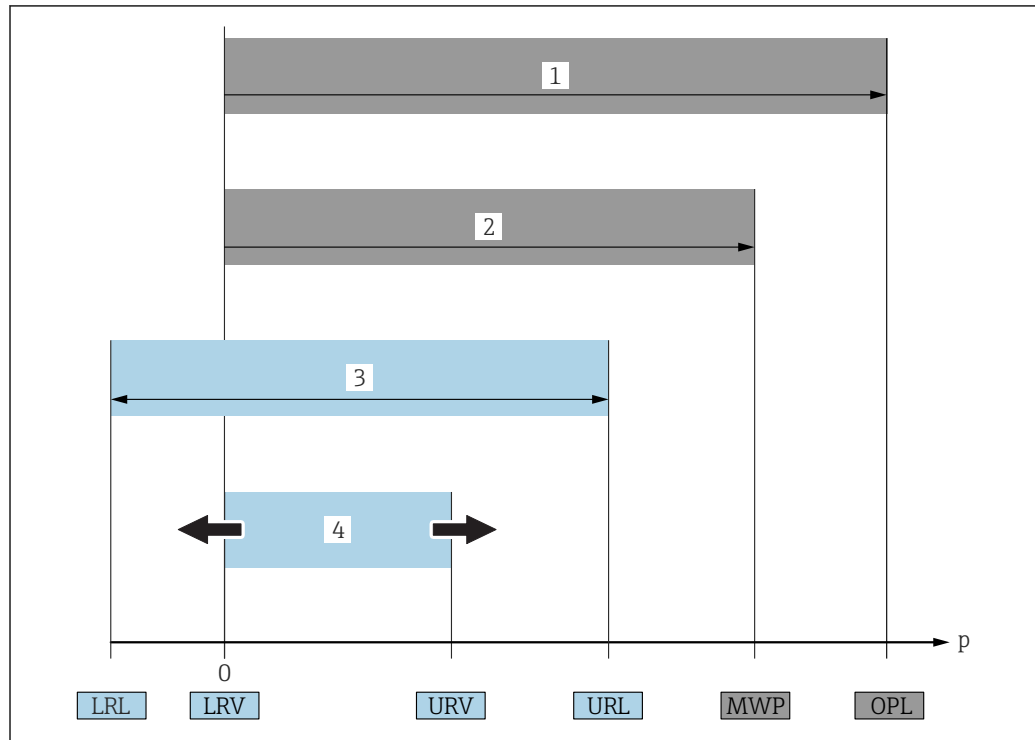

A0029505

Item	Term/ abbreviation	Explanation
1	OPL	The OPL (over pressure limit = sensor overload limit) for the measuring device depends on the lowest-rated element, with regard to pressure, of the selected components, i.e. the process connection has to be taken into consideration in addition to the measuring cell. Also observe pressure-temperature dependency. For the relevant standards and additional notes, see the "Pressure specifications" section → 20 . The OPL may only be applied for a limited period of time.
2	MWP	The MWP (maximum working pressure) for the sensors depends on the lowest-rated element, with regard to pressure, of the selected components, i.e. the process connection has to be taken into consideration in addition to the measuring cell. Also observe pressure-temperature dependency. For the relevant standards and additional notes, see the "Pressure specifications" section → 20 . The MWP may be applied at the device for an unlimited period. The MWP can also be found on the nameplate.
3	Maximum sensor measuring range	Span between LRL and URL This sensor measuring range is equivalent to the maximum calibratable/adjustable span.
4	Calibrated/ adjusted span	Span between LRV and URV Factory setting: 0 to URL Other calibrated spans can be ordered as customized spans.
p	-	Pressure
-	LRL	Lower range limit
-	URL	Upper range limit
-	LRV	Lower range value
-	URV	Upper range value
-	TD (turn down)	Turn down The turn down is preset at the factory and cannot be changed. Example - see the following section.

Turn down calculation

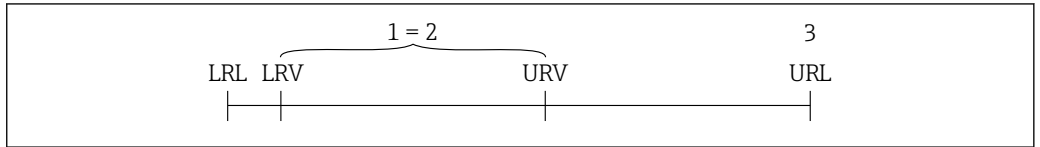

A0029545

- 1 Calibrated/adjusted span
- 2 Zero point-based span
- 3 URL sensor

Example

- Sensor: 10 bar (150 psi)
- Upper range value (URL) = 10 bar (150 psi)
- Calibrated/adjusted span: 0 to 5 bar (0 to 75 psi)
- Lower range value (LRV) = 0 bar (0 psi)
- Upper range value (URV) = 5 bar (75 psi)

Turn down (TD):

$$TD = \frac{URL}{|URV - LRV|}$$

$$TD = \frac{10 \text{ bar (150 psi)}}{|5 \text{ bar (75 psi)} - 0 \text{ bar (0 psi)}|} = 2$$

In this example, the TD is 2:1.
This span is based on the zero point.

Function and system design

Measuring principle - process pressure measurement

Devices with metallic process isolating diaphragm

The process pressure deflects the metal process isolating diaphragm of the sensor and a fill fluid transfers the pressure to a Wheatstone bridge (semiconductor technology). The pressure-dependent change in the bridge output voltage is measured and evaluated.

Advantages:

- Can be used for high process pressures
- Fully welded sensor
- Slim, flush-mounted process connections available

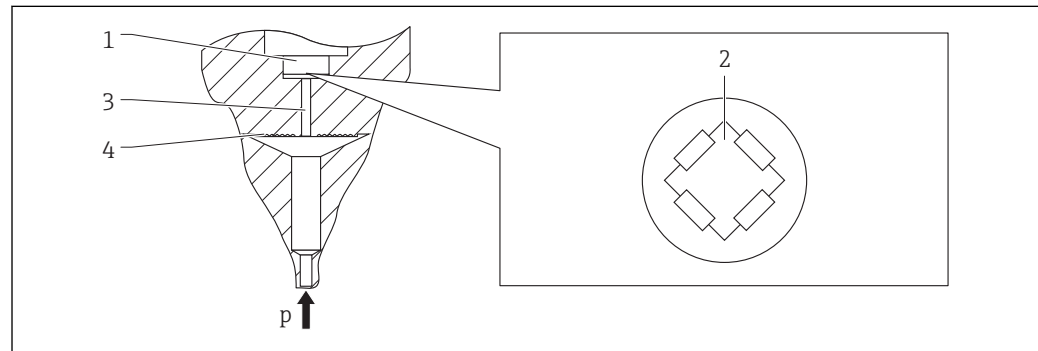

A0016448

- 1 Silicon measuring element, substrate
- 2 Wheatstone bridge
- 3 Channel with fill fluid
- 4 Metal process isolating diaphragm

Measuring system

A complete measuring system comprises:

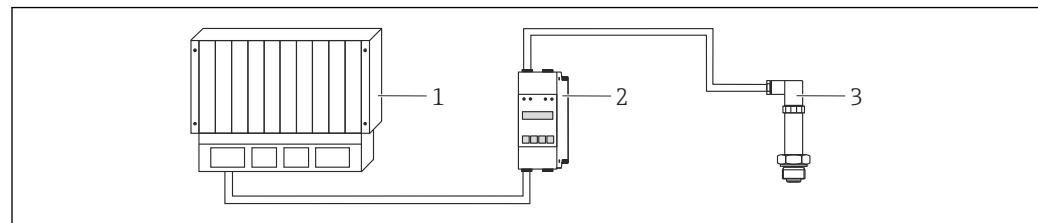

A0021926

- 1 PLC (programmable logic control)
- 2 e.g. RN221N / RMA42 (if required)
- 3 Pressure transducer

Device features

Field of application

PMP23: Gauge and absolute pressure and hygienic applications

Process connections

PMP23:

- Thread ISO 228
- Clamp/Tri-Clamp
- DIN 11851
- Thread M24 x 1.5
- Universal adapter
- SMS
- Varivent

Measuring ranges

PMP23: from -400 to +400 mbar (-6 to +6 psi) to -1 to +40 bar (-15 to +600 psi)

OPL (depends on the measuring range)

PMP23: max. 0 to +160 bar (0 to +2 400 psi)

MWP

PMP23: max. 0 to +160 bar (0 to +2 400 psi)

Process temperature range (temperature at process connection)

PMP23: -10 to +100 °C (+14 to +212 °F)
(+135 °C (+275 °F) for one hour maximum)

Ambient temperature range

PMP23:

- -40 to +85 °C (-40 to +185 °F)
- Devices for hazardous areas: -40 to +70 °C (-40 to +158 °F)

Devices with IO-Link:

-40 to +70 °C (-40 to +158 °F)

Reference accuracy

PMP23: up to 0.3 %, TD 5:1

Supply voltage

PMP23:

10 to 30 V DC

Output

PMP23:

4 to 20 mA

Devices with IO-Link:

c/Q output for communication (SIO mode (switch output))

Material

PMP23:

- Housing made from 316L (1.4404)
- Process connections made from 316L (1.4435)
- Process isolating diaphragm made from 316L (1.4435)

Options

PMP23:

- Ex approvals
- Min. alarm current setting
- 3.1 Material certificates
- EHEDG/3A approvals
- Certificate of calibration
- Weld-in adapter
- IP69
- IO-Link

Product design

Overview	Item	Description
	A	Valve plug
	B	Cable
	C- 1	M12 plug Housing cap made of plastic
	C- 2	M12 plug For Ex ec and IP69: metal housing cap Metal housing cap can also be ordered as an option.
	D E	Housing Process connection (sample illustration)

System integration

The device can be given a tag name (max. 32 alphanumeric characters).

Designation	Option ¹⁾
Measuring point (TAG), see additional specifications	Z1

1) Product Configurator order code for "Marking"

For devices with IO-Link, an IO-DD is available in the Downloads area of the Endress+Hauser website → 30.

Input

Measured variable	Measured process variable PMP23: Gauge pressure or absolute pressure
	Calculated process variable Pressure

Measuring range **Metal process isolating diaphragm**

Sensor	Device	Maximum Sensor measuring range		Lowest calibratable span ¹⁾	MWP	OPL	Factory settings ²⁾	Option ³⁾
		lower (LRL)	upper (URL)					
		[bar (psi)]	[bar (psi)]					
Devices for gauge pressure measurement								
400 mbar (6 psi) ⁴⁾	PMP23	-0.4 (-6)	+0.4 (+6)	0.4 (6)	1 (15)	1.6 (24)	0 to 400 mbar (0 to 6 psi)	1F
1 bar (15 psi) ⁴⁾	PMP23	-1 (-15)	+1 (+15)	0.4 (6)	2.7 (40.5)	4 (60)	0 to 1 bar (0 to 15 psi)	1H
2 bar (30 psi) ⁴⁾	PMP23	-1 (-15)	+2 (+30)	0.4 (6)	6.7 (100.5)	10 (150)	0 to 2 bar (0 to 30 psi)	1K
4 bar (60 psi) ⁴⁾	PMP23	-1 (-15)	+4 (+60)	0.8 (12)	10.7 (160.5)	16 (240)	0 to 4 bar (0 to 60 psi)	1M
6 bar (90 psi) ⁴⁾	PMP23	-1 (-15)	+6 (+90)	2.4 (36)	16 (240)	24 (360)	0 to 6 bar (0 to 90 psi)	1N
10 bar (150 psi) ⁴⁾	PMP23	-1 (-15)	+10 (+150)	2 (30)	25 (375)	40 (600)	0 to 10 bar (0 to 150 psi)	1P
16 bar (240 psi) ⁴⁾	PMP23	-1 (-15)	+16 (+240)	5 (75)	25 (375)	64 (960)	0 to 16 bar (0 to 240 psi)	1Q
25 bar (375 psi) ⁴⁾	PMP23	-1 (-15)	+25 (+375)	5 (75)	25 (375)	100 (1500)	0 to 25 bar (0 to 375 psi)	1R
40 bar (600 psi) ⁴⁾	PMP23	-1 (-15)	+40 (+600)	8 (120)	100 (1500)	160 (2400)	0 to 40 bar (0 to 600 psi)	1S
Devices for absolute pressure measurement								
400 mbar (6 psi) ⁴⁾	PMP23	0 (0)	0.4 (+6)	0.4 (6)	1 (15)	1.6 (24)	0 to 400 mbar (0 to 6 psi)	2F
1 bar (15 psi) ⁴⁾	PMP23	0 (0)	1 (+15)	0.4 (6)	2.7 (40.5)	4 (60)	0 to 1 bar (0 to 15 psi)	2H
2 bar (30 psi) ⁴⁾	PMP23	0 (0)	2 (+30)	0.4 (6)	6.7 (100.5)	10 (150)	0 to 2 bar (0 to 30 psi)	2K
4 bar (60 psi) ⁴⁾	PMP23	0 (0)	4 (+60)	0.8 (12)	10.7 (160.5)	16 (240)	0 to 4 bar (0 to 60 psi)	2M
10 bar (150 psi) ⁴⁾	PMP23	0 (0)	10 (+150)	2 (30)	25 (375)	40 (600)	0 to 10 bar (0 to 150 psi)	2P
40 bar (600 psi) ⁴⁾	PMP23	0 (0)	+40 (+600)	8 (120)	100 (1500)	160 (2400)	0 to 40 bar (0 to 600 psi)	2S

- 1) Highest turn down that can be set at the factory: 5:1. The turn down is preset and cannot be changed.
- 2) Other measuring ranges (e.g. -1 to +5 bar (-15 to 75 psi)) can be ordered with customer-specific settings (see the Product Configurator, order code for "Calibration; Unit" option "J"). It is possible to invert the output signal (LRV = 20 mA; URV = 4 mA). Prerequisite: URV < LRV
- 3) Product Configurator, order code for "Sensor range"
- 4) Vacuum resistance: 0.01 bar (0.145 psi) abs

Maximum turn down which can be ordered for absolute pressure and gauge pressure sensors

Device	Range	400 mbar (6 psi)	1 bar (15 psi) 6 bar (90 psi) 16 bar (240 psi)	2 bar (30 psi) 4 bar (60 psi) 10 bar (150 psi) 25 to 40 bar (375 to 600 psi)
PMP23	0.3%	TD 1:1	TD 1:1 to TD 2.5:1	TD 1:1 to TD 5:1

Output

Output signal	Designation	Option ¹⁾
	4 to 20 mA (2-wire)	1
	IO-Link 4 to 20 mA (3-wire or 4-wire)	7

1) Product Configurator, order code for "Output"

Switching capacity	
	<ul style="list-style-type: none"> ■ Devices with IO-Link: Switch status ON: $I_a \leq 200 \text{ mA}$ ^{1) 2)}; switch status OFF: $I_a \leq 1 \text{ mA}$ ■ Switch cycles: >10,000,000 ■ Voltage drop PNP: $\leq 2 \text{ V}$ ■ Overload protection: Automatic load testing of switching current; <ul style="list-style-type: none"> ■ Max. capacitive load: 14 μF at max. supply voltage (without resistive load) ■ Devices with IO-Link: Max. capacitive load: 1 μF at max. supply voltage (without resistive load) ■ Max. cycle duration: 0.5 s; min. t_{on}: 4 ms ■ Max. cycle duration: 0.5 s; min. t_{on}: 40 μs ■ Periodic disconnection from protective circuit in the event of overcurrent ($f = 2 \text{ Hz}$) and "F804" displayed

Signal range 4 to 20 mA	3.8 mA to 20.5 mA
-------------------------	-------------------

Load (for 4 to 20 mA devices)	In order to guarantee sufficient terminal voltage in two-wire devices, a maximum load resistance R_L (including line resistance) must not be exceeded depending on the supply voltage U_B of the supply unit.
--------------------------------	---

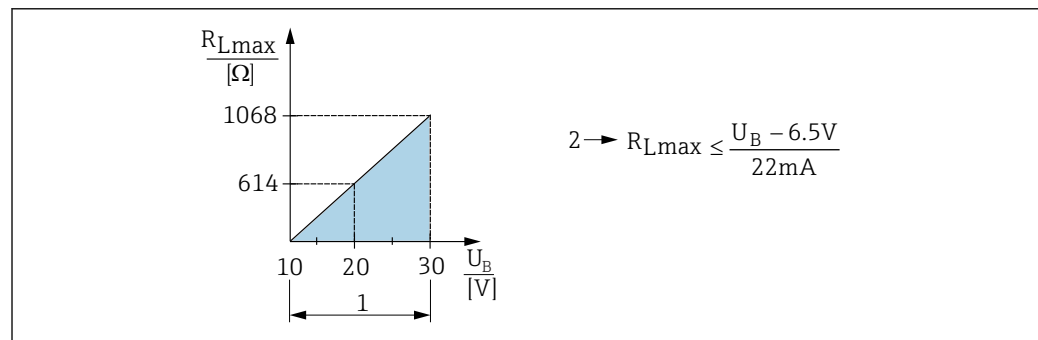

A0029452

- 1 Power supply 10 to 30 VDC
 2 $R_{L\text{max}}$ Maximum load resistance
 U_B Supply voltage

Devices with IO-Link

In order to guarantee sufficient terminal voltage, a maximum load resistance R_L (including line resistance) must not be exceeded depending on the supply voltage U_B of the supply unit.

- 1) 100 mA can be guaranteed over the entire temperature range for the switch output 1 x PNP + 4 to 20 mA output. For lower ambient temperatures, higher currents are possible but cannot be guaranteed. Typical value at 20 °C (68 °F) approx. 200 mA. 200 mA can be guaranteed over the entire temperature range for the "1 x PNP" switch output.
- 2) Larger currents are supported, thus deviating from the IO-Link standard.

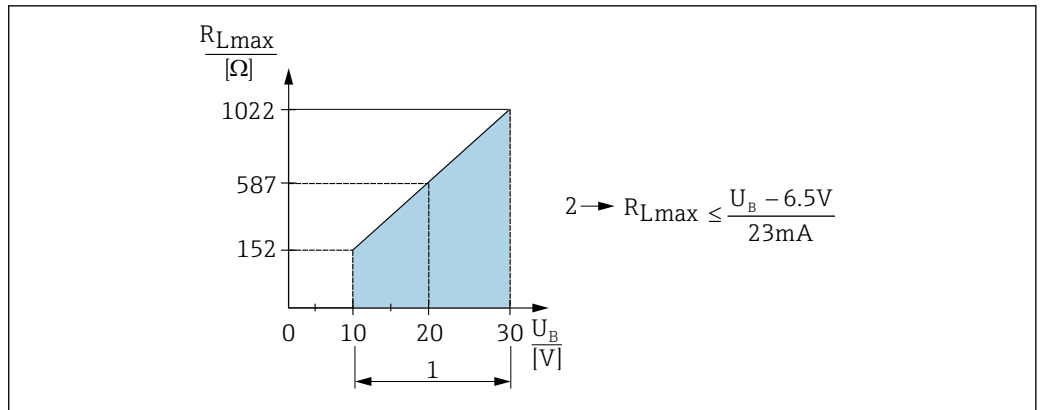

A0031107

- 1 Power supply 10 to 30 V DC
- 2 R_{Lmax} Maximum load resistance
- U_B Supply voltage

- Error current is output and "S803" displayed (output: MIN alarm current)
- Periodic checking to establish if it is possible to quit fault state

Signal on alarm 4 to 20 mA

The response of the output to error is regulated in accordance with NAMUR NE43.
 Factory setting MAX alarm: >21 mA

alarm current

Device	Description	Option
PMP23	Adjusted min. alarm current	IA ¹⁾

1) Product Configurator order code for "Service"

Dead time, time constant

Presentation of the dead time and the time constant:

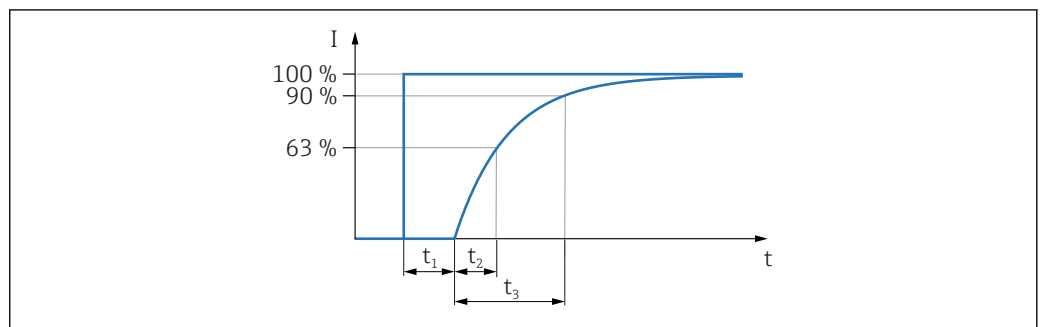

A0019786

Dynamic behavior

Dead time (t_1) [ms]	Time constant (T63), t_2 [ms]	Time constant (T90), t_3 [ms]
6 ms	10 ms	15 ms

Devices with IO-Link:

Dead time (t_1) [ms]	Time constant (T63), t_2 [ms]	Time constant (T90), t_3 [ms]
7 ms	11 ms	16 ms

Dynamic behavior of switch output

Response time ≤ 20 ms

Power supply

⚠ WARNING

Electrical safety is compromised by an incorrect connection!

- ▶ In accordance with IEC/EN61010 a suitable circuit breaker must be provided for the device .
- ▶ When using the measuring device in hazardous areas, installation must comply with the corresponding national standards and regulations and the Safety Instructions or Installation or Control Drawings.
- ▶ All explosion protection data are given in separate documentation which is available upon request. The Ex documentation is supplied as standard with all devices approved for use in explosion hazardous areas.
- ▶ Protective circuits against reverse polarity, HF influences and overvoltage peaks are integrated.
- ▶ The device must be operated with a 500 mA fine-wire fuse (slow-blow).

Terminal assignment

4 to 20 mA output

Device	M12 plug	Valve plug	Cable
PMP23	<p>A0023487</p>	<p>A0022823</p>	<p>A0023783</p> <p>1 brown = L+ 2 blue = L- 3 green/yellow = ground connection (a) reference air hose</p>

Devices with IO-Link

Device	M12 plug
PMP23	<p>A0034006</p> <p>1 Supply voltage + 2 4-20 mA 3 Supply voltage - 4 C/Q (IO-Link communication or SIO mode)</p>

Supply voltage

Electronic version	Device	Supply voltage
4 to 20 mA output	PMP23	10 to 30 V DC
IO-Link	PMP23	10 to 30 V DC IO-Link communication is guaranteed only if the supply voltage is at least 18 V.

Current consumption and alarm signal

Electronic version	Device	Current consumption	Alarm signal ¹⁾
4 to 20 mA output	PMP23	≤ 26 mA	> 21 mA
IO-Link	PMP23 with IO-Link	Maximum current consumption: ≤ 300 mA	

1) For MAX alarm (factory setting)

Power supply fault

- Behavior in the event of overvoltage (>30 V):
The device works continuously up to 34 V DC without damage. If the supply voltage is exceeded, the specified characteristics are no longer guaranteed.
- Behavior in the event of undervoltage:
If the supply voltage falls below the minimum value, the device switches off in a defined manner.

Electrical connection

Degree of protection

Device	Connection	Degree of protection	Option ¹⁾
PMP23	Cable 5 m (16 ft)	IP66/68 ²⁾ NEMA type 4X/6P enclosure	A
PMP23	Cable 10 m (33 ft)	IP66/68 ²⁾ NEMA type 4X/6P enclosure	B
PMP23	Cable 25 m (82 ft)	IP66/68 ²⁾ NEMA type 4X/6P enclosure	C
PMP23	M12 plug	IP65/67 NEMA type 4X enclosure	M
PMP23	M12 plug made of metal	IP66/69 ³⁾ NEMA type 4X enclosure	N
PMP23	Valve plug ISO4400 M16	IP65 NEMA type 4X enclosure	U
PMP23	Valve plug ISO4400 NPT ½	IP65 NEMA type 4X enclosure	V

- 1) Product Configurator order code for "Electrical connection"
- 2) IP 68 (1.83m H2O for 24 h)
- 3) Designation of the IP protection class according to DIN EN 60529. Previous designation "IP69K" according to DIN 40050 Part 9 is no longer valid (standard withdrawn on November 1, 2012). The tests required by both standards are identical.

Cable specification

For valve plug: < 1.5 mm² (16 AWG) and Ø4.5 to 10 mm (0.18 to 0.39 in)

Residual ripple

The device operates within the reference accuracy up to ±5 % of the residual ripple of the supply voltage, within the permitted voltage range.

Influence of power supply

≤0.005 % of URV/1 V

Overvoltage protection

The device does not contain any special elements to protect against overvoltage ("wire to ground"). Nevertheless the requirements of the applicable EMC standard EN 61000-4-5 (testing voltage 1kV EMC wire/ground) are met.

Performance characteristics of metal process isolating diaphragm

Reference operating conditions

- As per IEC 60770
- Ambient temperature T_A = constant, in the range: +21 to +33 °C (+70 to +91 °F)
- Humidity φ = constant, in the range: 5 to 80 % rH
- Ambient pressure p_A = constant, in the range: 860 to 1060 mbar (12.47 to 15.37 psi)
- Position of measuring cell = constant, in the range: horizontal $\pm 1^\circ$ (see also "Influence of the installation position" section → [17](#))
- Zero based span
- Process isolating diaphragm material: AISI 316L (1.4435)
- Filling oil: synthetic oil polyalphaolefin FDA 21 CFR 178.3620, NSF H1
- Supply voltage: 24 V DC ± 3 V DC
- Load: 320 Ω (at 4 to 20 mA output)

Measuring uncertainty for small absolute pressure measuring ranges

- The smallest extended uncertainty of measurement that can be delivered by our standards is:**
- in the range 1 to 30 mbar (0.0145 to 0.435 psi): 0.4 % of reading
 - in the range < 1 mbar (0.0145 psi): 1 % of reading.

Influence of the installation position

→ [17](#)

Resolution

Current output: min. 1.6 μ A

Reference accuracy

The reference accuracy contains the non-linearity [DIN EN 61298-2 3.11] including the pressure hysteresis [DIN EN 61298-23.13] and non-repeatability [DIN EN 61298-2 3.11] in accordance with the limit point method as per [DIN EN 60770].

Device	% of the calibrated span to the maximum turn down		
	Reference accuracy	Non-linearity	Non-repeatability
PMP23	± 0.3	± 0.1	± 0.1

Overview of the turn down ranges → [11](#)

Thermal change of the zero output and the output span

Measuring cell	-20 to +85 °C (-4 to +185 °F)		-40 to -20 °C (-40 to -4 °F) +85 to +100 °C (+185 to +212 °F)	
	% of the calibrated span for TD 1:1			
<1 bar (15 psi)	<1		<1.2	
≥ 1 bar (15 psi)	<0.8		<1	

Long-term stability

Device	1 year	5 years	8 years
	% of URL		
PMP23	± 0.2	± 0.4	± 0.45
Devices with IO-Link	± 0.2	± 0.4	± 0.45

Switch-on time

≤ 2 s

The following applies for IO-Link: For small measuring ranges, pay attention to the thermal compensation effects.

Installation

Installation conditions

- Moisture must not penetrate the housing when mounting the device, establishing the electrical connection and during operation.
- Point the cable and connector downwards where possible to prevent moisture from entering (e.g. rain or condensation water).

Influence of the installation position

Any orientation is possible. However, the orientation may cause a zero point shift i.e. the measured value does not show zero when the vessel is empty or partially full.

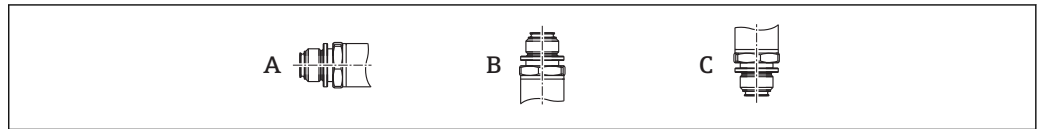

A0024708

Type	Process isolating diaphragm axis is horizontal (A)	Process isolating diaphragm pointing upwards (B)	Process isolating diaphragm pointing downwards (C)
PMP23	Calibration position, no effect	Up to +4 mbar (+0.058 psi)	Up to -4 mbar (-0.058 psi)

Mounting location

Pressure measurement

Pressure measurement in gases

Mount the device with shutoff device above the tapping point so that any condensate can flow into the process.

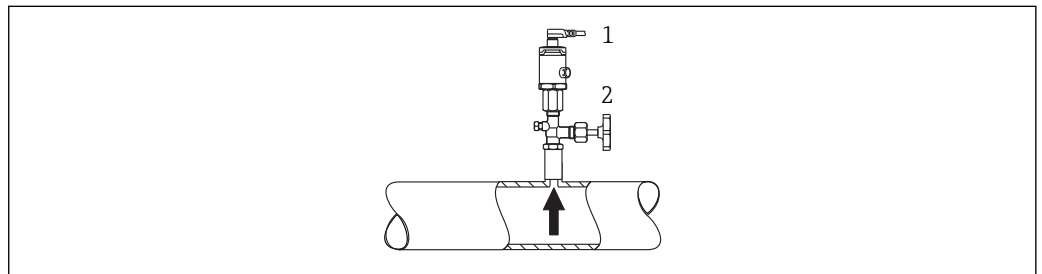

A0021904

- Device
- Shutoff device

Pressure measurement in vapors

For pressure measurement in vapors, use a siphon. The siphon reduces the temperature to almost ambient temperature. Mount the device with a shutoff device at the same height as the tapping point.

Advantage:
only minor/negligible heat effects on the device.

Note the max. permitted ambient temperature of the transmitter!

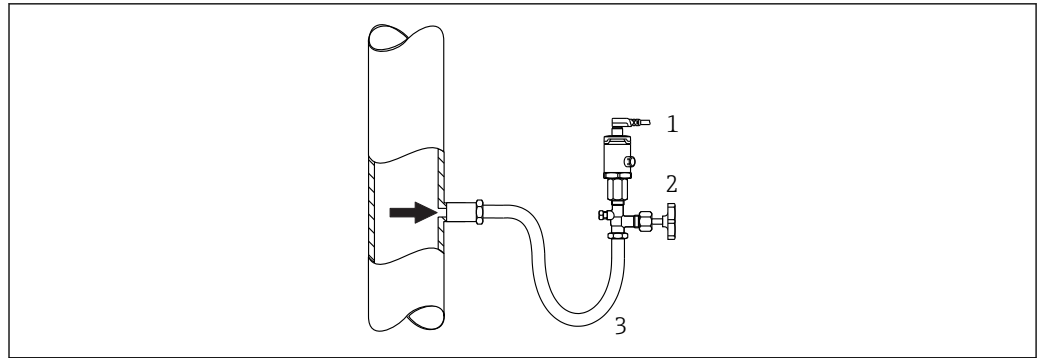

A0024395

- 1 Device
- 2 Shutoff device
- 3 Siphon

Pressure measurement in liquids

Mount the device with a shutoff device at the same height as the tapping point.

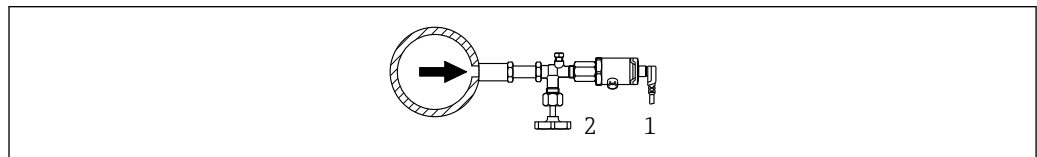

A0024399

- 1 Device
- 2 Shutoff device

Level measurement

- Always install the device below the lowest measuring point.
- Do not install the device at the following positions:
 - In the filling curtain
 - In the tank outlet
 - in the suction area of a pump
 - Or at a point in the tank which could be affected by pressure pulses from the agitator.

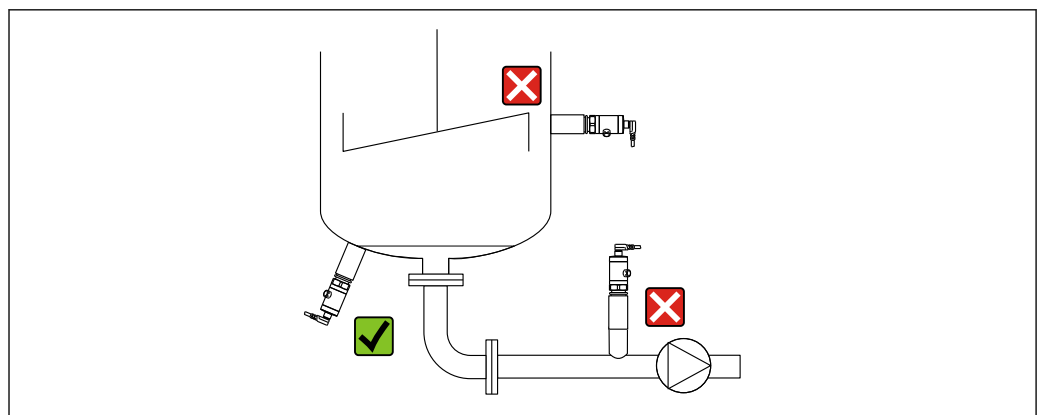

A0024405

Environment

Ambient temperature range	Device	Ambient temperature range ¹⁾
	PMP23	-40 to +85 °C (-40 to +185 °F)
	PMP23 with IO-Link	-40 to +70 °C (-40 to +158 °F)
	PMP23	Devices for hazardous areas: -40 to +70 °C (-40 to +158 °F)

- 1) Exception: the following cable is designed for an ambient temperature range of -25 to +70 °C (-13 to +158 °F): Product Configurator order code for "Enclosed accessories" option "RZ".

Storage temperature range -40 to +85 °C (-40 to +185 °F)

Climate class	Device	Climate class	Note
	PMP23	Class 4K4H	Air temperature: -20 to +55 °C (-4 to +131 °F), relative humidity: 4 to 100 % satisfied according to DIN EN 60721-3-4 (condensation is possible)

Degree of protection	Device	Connection	Degree of protection	Option ¹⁾
	PMP23	Cable 5 m (16 ft)	IP66/68 ²⁾ NEMA type 4X/6P enclosure	A
	PMP23	Cable 10 m (33 ft)	IP66/68 ²⁾ NEMA type 4X/6P enclosure	B
	PMP23	Cable 25 m (82 ft)	IP66/68 ²⁾ NEMA type 4X/6P enclosure	C
	PMP23	M12 plug	IP65/67 NEMA type 4X enclosure	M
	PMP23	M12 plug made of metal	IP66/69 ³⁾ NEMA type 4X enclosure	N
	PMP23	Valve plug ISO4400 M16	IP65 NEMA type 4X enclosure	U
	PMP23	Valve plug ISO4400 NPT ½	IP65 NEMA type 4X enclosure	V

- 1) Product Configurator order code for "Electrical connection"
 2) IP 68 (1.83m H₂O for 24 h)
 3) Designation of the IP protection class according to DIN EN 60529. Previous designation "IP69K" according to DIN 40050 Part 9 is no longer valid (standard withdrawn on November 1, 2012). The tests required by both standards are identical.

Vibration resistance	Test standard	Vibration resistance
	IEC 60068-2-64:2008	Guaranteed for 5 to 2000Hz: 0.05g ² /Hz

Electromagnetic compatibility

- Interference emission as per EN 61326-1 equipment B
- Interference immunity as per EN 61326-1 (industrial environment)
 Devices with IO-Link: For intended use, the switch output can switch to the communication mode for 0.2 s in the event of transient faults (only for devices with IO-Link).
- NAMUR recommendation EMC (NE21) (not for devices with IO-Link)
- Maximum deviation: 1.5% with TD 1:1

For more details please refer to the Declaration of Conformity (devices without IO-Link).

Process

Process temperature range for devices with metallic process isolating diaphragm

Device	Process temperature range
PMP23	-10 to +100 °C (+14 to +212 °F)
PMP23 Sterilization in place (SIP)	At +135°C (+275 °F) for a maximum of one hour (device in operation but not within measuring specification)

Applications with changes in temperature

Frequent extreme changes in temperatures can temporarily cause measuring errors. Internal temperature compensation is faster the smaller the change in temperature and the longer the time interval.

For further information please contact your local Endress+Hauser Sales Center.

Pressure specifications

WARNING

The maximum pressure for the measuring device depends on the lowest-rated element with regard to pressure.

- ▶ For pressure specifications, see the "Measuring range" section and the "Mechanical construction" section.
- ▶ The Pressure Equipment Directive (2014/68/EU) uses the abbreviation "PS". The abbreviation "PS" corresponds to the MWP (maximum working pressure) of the measuring device.
- ▶ MWP (maximum working pressure): The MWP (maximum working pressure) is specified on the nameplate. This value is based on a reference temperature of +20 °C (+68 °F) and may be applied to the device for an unlimited period of time. Observe the temperature dependency of the MWP.
- ▶ OPL (over pressure limit): The test pressure corresponds to the over pressure limit of the sensor and may only be applied temporarily to ensure that the measurement is within the specifications and no permanent damage develops. In the case of sensor range and process connections where the over pressure limit (OPL) of the process connection is smaller than the nominal value of the sensor, the device is set at the factory, at the very maximum, to the OPL value of the process connection. If you want to use the entire sensor range, select a process connection with a higher OPL value.

Mechanical construction



For the dimensions, see the Product Configurator: www.endress.com

Search for product → click "Configuration" to the right of the product image → after configuration click "CAD"

The following dimensions are rounded values. For this reason, they may deviate slightly from the dimensions given on www.endress.com.

Design, dimensions

Device height

The device height is calculated from

- the height of the electrical connection
- the height of the housing and
- the height of the individual process connection.

The individual heights of the components are listed in the following sections. To calculate the device height simply add up the individual heights of the components. Where applicable also take into consideration the installation distance (space that is used to install the device). You can use the following table for this purpose:

Section	Page	Height	Example
Electrical connection	→ 21	(A)	
Housing height	→ 22	(B)	
Process connection height	→ 23	(C)	
Installation distance	-	(D)	

Electrical connection

Engineering unit mm (in)			

Item	Designation	Material	Weight kg (lbs)	Device	Option ¹⁾
A	M12 plug IP65/67 (Additional dimensions → 38)	Housing cap made of plastic	0.012 (0.03)	PMP23	M Plug connector with cable can be ordered as an accessory → 38
B	M12 plug IP66/69	Housing cap made of metal	0.030 (0.07)	PMP23	In the case of Ex ec type of protection, the housing cap is made of metal. Can be ordered separately via option "N".
C	M16 valve plug	Plastic PPSU	0.060 (0.14)	PMP23	U
C	NPT ½ valve plug	Plastic PPSU	0.060 (0.14)	PMP23	V

Item	Designation	Material	Weight kg (lbs)	Device	Option ¹⁾
D	Cable5 m (16 ft)	PUR (UL94V0)	0.280 (0.62)	PMP23	A
D	Cable10 m (33 ft)	PUR (UL94V0)	0.570 (1.26)	PMP23	B
D	Cable25 m (82 ft)	PUR (UL94V0)	1.400 (3.09)	PMP23	C

1) Product Configurator, order code for "Electrical connection"

Housing

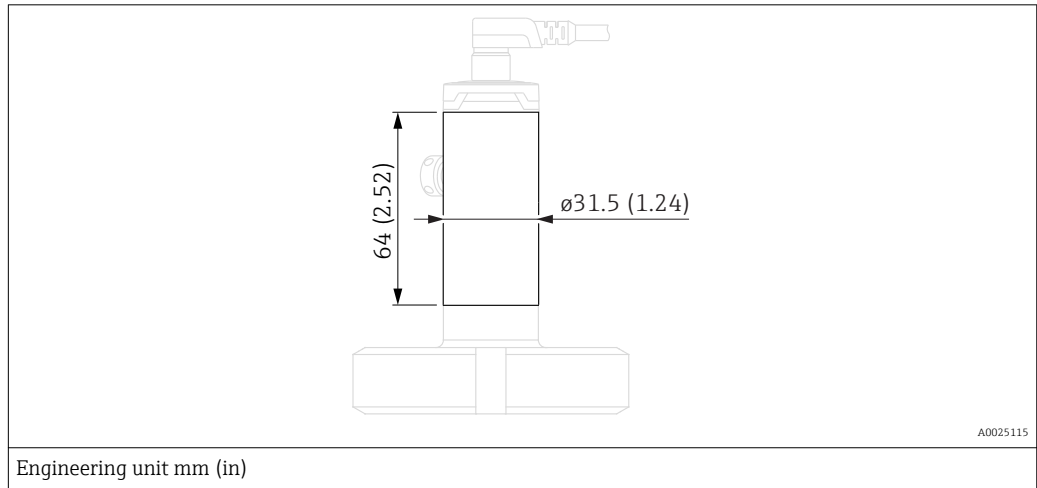

Device	Material	Weight kg (lbs)
PMP23	Stainless steel 316L	0.100 (0.22)

Process connections with
flush mount, metal process
isolating diaphragm

Thread ISO 228 G

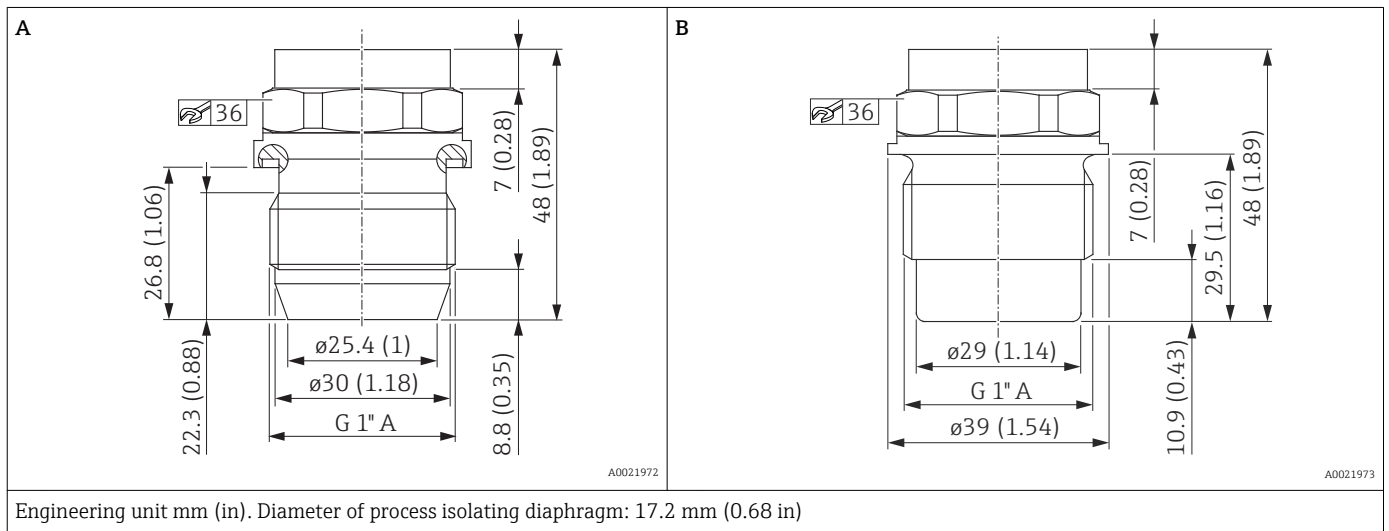

Item	Description	Seal	Material	Weight	Approval	Option ¹⁾
				kg (lbs)		
A	Thread ISO 228 G 1" A	Metal joint	316L	0.270 (0.60)	CRN	WQJ
B	Thread ISO 228 G 1" A	Seal established via O-ring. VMQ O-ring is enclosed with QJ and QK accessories.	316L	0.270 (0.60)	EHEDG, 3A ²⁾ , CRN	WSJ

- 1) Product Configurator, order code for "Process connection"
- 2) EHEDG and 3A only in conjunction with weld-in adapter → 37

Thread M24 x 1.5

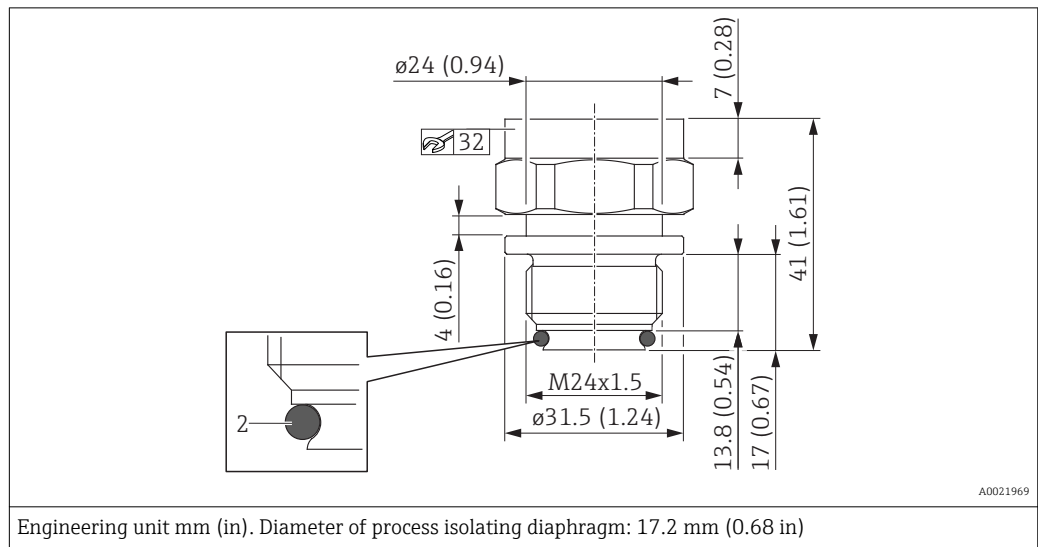

Designation	Seal	Material	Weight	Approval	Option ¹⁾
			kg (lbs)		
M24 x 1.5 ²⁾	EPDM O-ring (2), pre-mounted	316L	0.150 (0.33)	EHEDG, 3A, CRN	X2J
M24 x 1.5 ²⁾	FKM O-ring (2), pre-mounted	316L	0.150 (0.33)	EHEDG, 3A, CRN	X3J

- 1) Product Configurator, order code for "Process connection"
- 2) torque 65 Nm (48 lbf ft)

Hygienic connections

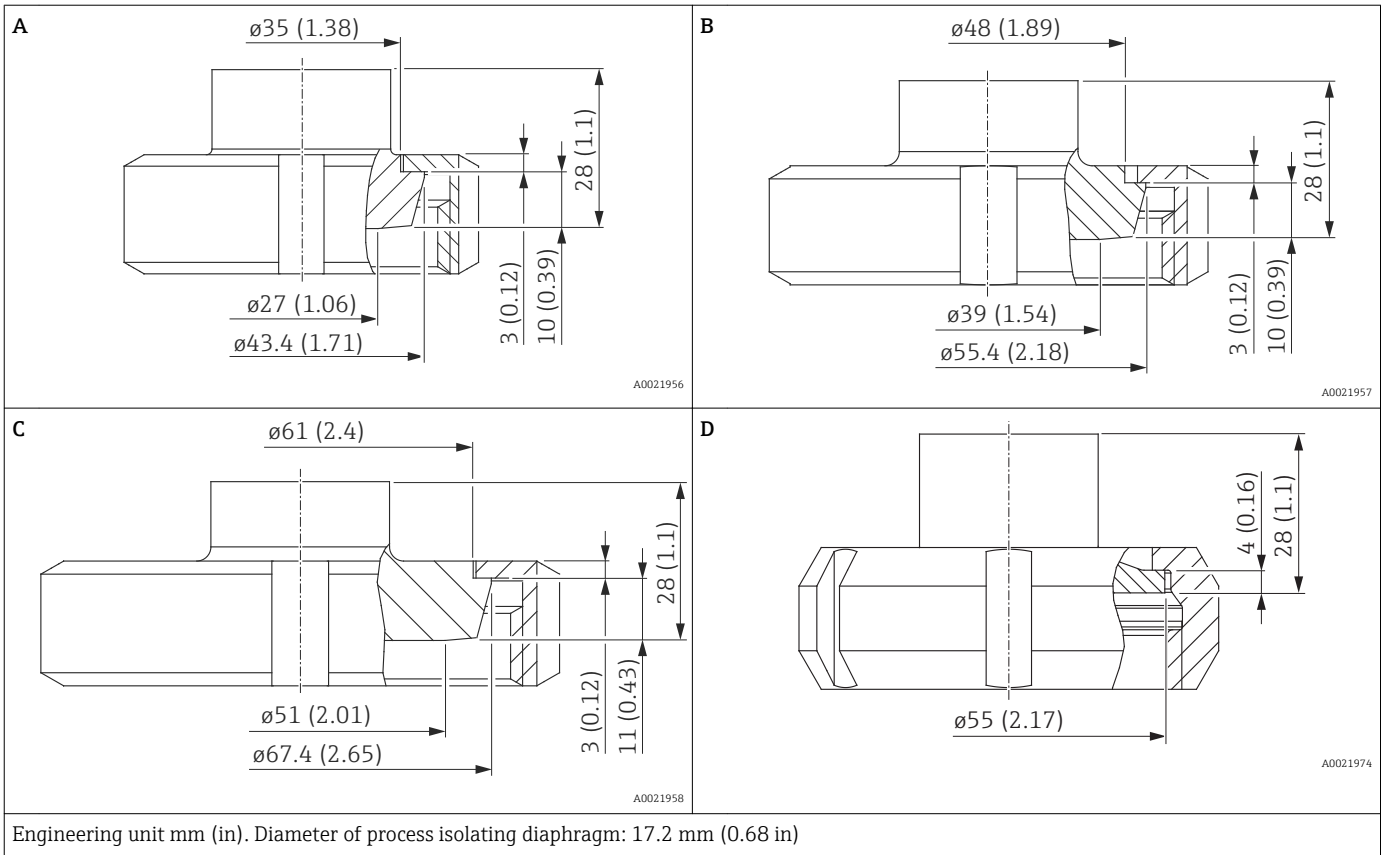

Position	Designation	Nominal pressure	Material ¹⁾	Weight	Approval	Option ²⁾
		PN		kg (lbs)		
A	DIN 11851 DN 25	40	316L	0.360 (0.79)	3A, EHEDG, CRN	1GJ
B	DIN 11851 DN 40	40	316L	0.520 (1.15)	3A, EHEDG, CRN	1JJ
C	DIN 11851 DN 50	25	316L	0.760 (1.68)	3A, EHEDG, CRN	1DJ
D	SMS 1 ½"	25	316L	0.440 (0.97)	3A, CRN	4QJ

- 1) Roughness of wetted surfaces Ra ≤ 0.76 µm (29.9 µin).
- 2) Product Configurator, order code for "Process connection"

Hygienic connections

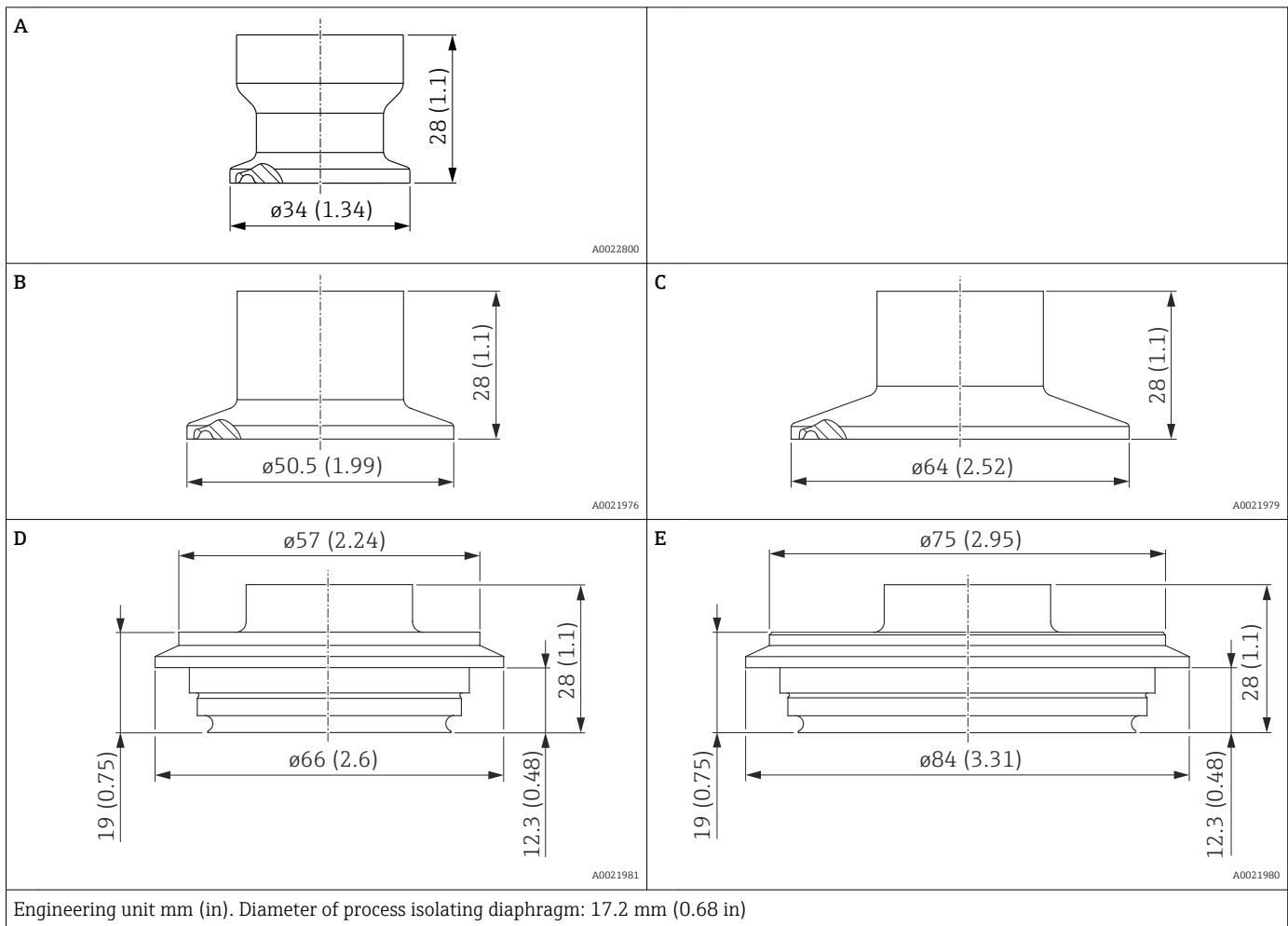

Item	Designation	Approval	Nominal pressure	Material ¹⁾	Weight	Option ²⁾
			PN		kg (lbs)	
A	Clamp ISO 2852 DN22	3A, EHEDG, CRN	40	316L	0.090 (0.20)	3AJ
B	Tri-Clamp ISO 2852 DN 25 – DN 38 (1" - 1 ½"), DIN32676 DN25-38	3A, EHEDG, CRN	40	316L	0.160 (0.35)	3CJ
C	Tri-Clamp ISO 2852 DN 40 – DN 51 (2"), DIN32676 DN50, EHEDG, 3A	3A, EHEDG, CRN	40	316L	0.230 (0.51)	3EJ
D	Varivent F pipe DN25-32	3A, EHEDG, CRN	40	316L	0.350 (0.77)	41J
E	Varivent N pipe DN40-162	3A, EHEDG, CRN	40	316L	0.630 (1.39)	42J

- 1) Roughness of wetted surfaces $R_a \leq 0.76 \mu\text{m}$ (29.9 μin).
- 2) Product Configurator, order code for "Process connection"

Hygienic connections

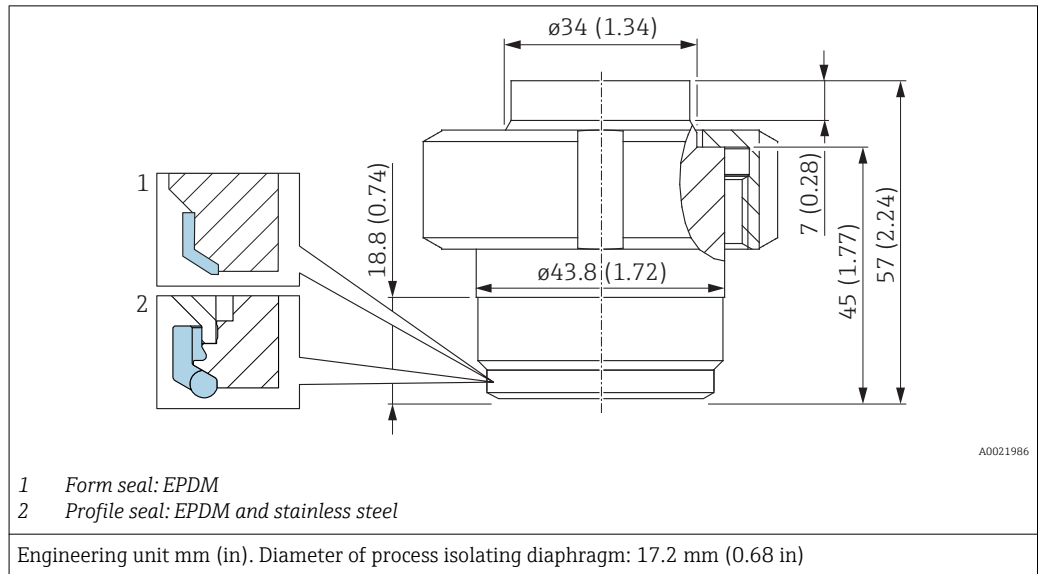

EPDM form seal: FDA, USP Class VI; 5 pcs, order number: 71100719

EPDM and stainless steel profile seal: FDA, USP Class VI; 1 pc, order number: 71431380

Material ¹⁾	Designation	Nominal pressure	Weight	Approval ²⁾	Option ³⁾
		bar (psi)	kg (lb)		
316L	Universal process adapter Form seal made of <ul style="list-style-type: none"> ■ EPDM (1) or ■ EPDM and stainless steel (2) 	10 (145)	0.730 (1.61)	CRN For more, see Product Configurator	52J

- 1) Roughness of wetted surface Ra ≤ 0.76 μm (29.9 μin).
- 2) CSA approval: Product Configurator, order code for "Approval"
- 3) Product Configurator, order code for "Process connection"

Materials in contact with process**NOTICE**

- ▶ Device components in contact with the process are listed in the "Mechanical construction" and "Ordering information" sections.

TSE Certificate of Suitability

The following applies to all device components in contact with the process:

- They do not contain any materials derived from animals.
- No additives or operating materials derived from animals are used in production or processing.

Process connections

- Endress+Hauser supplies a threaded connection made of stainless steel in accordance with AISI 316L (DIN/ EN material number 1.4404 or 1.4435). With regard to their stability-temperature property, the materials 1.4404 and 1.4435 are grouped together under 13E0 in EN 1092-1: 2001 Tab. 18. The chemical composition of the two materials can be identical.
- "Clamp connections" and "Hygienic process connections": AISI 316L (DIN/EN material number 1.4435)

Process isolating diaphragm

Description	Material
Metal process isolating diaphragm	AISI 316L (DIN/EN material number 1.4435)

Seals

See the specific process connection.

Materials not in contact with process **Housing**

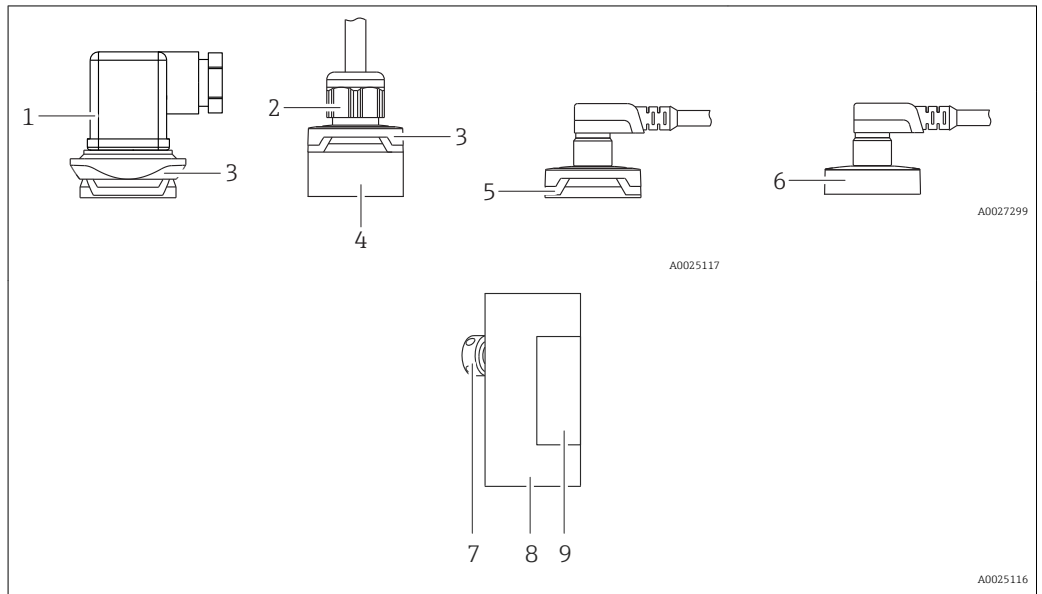

Item number	Component part	Material
1	Valve plug	<ul style="list-style-type: none"> ■ Seal: NBR ■ Plug: PA ■ Screw: V2A
2	Cable	<ul style="list-style-type: none"> ■ Pressure screw: PVDF ■ Seal: TPE-V ■ Cable: PUR (UL 94 V0)
3	Design element	PBT/PC
4	Connection	PPSU
5	M12 plug	Plastic: PPSU
6	M12 plug	316L (1.4404) Metal housing cap can be ordered as an option. For Ex ec: metal housing cap
7	Pressure compensation element	316L (1.4404)
8	Housing	316L (1.4404)
9	Nameplates	Lasered directly onto the housing

Filling oil

Device	Filling oil
PMP23	Synthetic oil polyalphaolefin FDA 21 CFR 178.3620, NSF H1

Cleaning

Device	Description	Option ¹⁾
PMP23	Cleaned from oil+grease	HA

1) Product Configurator, order code for "Service"

Operability

IO-Link (optional)

Operating concept for devices with IO-Link

Operator-oriented menu structure for user-specific tasks

Quick and safe commissioning

Guided menus for applications

Reliable operation

Operation in the following languages:

Via IO-Link: English

Efficient diagnostics increase measurement availability

- Remedial measures
- Simulation options

IO-Link information

IO-Link is a point-to-point connection for communication between the measuring device and an IO-Link master. The measuring device features an IO-Link communication interface type 2 with a second IO function on pin 4. This requires an IO-Link-compatible assembly (IO-Link master) for operation. The IO-Link communication interface enables direct access to the process and diagnostic data. It also provides the option of configuring the measuring device while in operation.

Physical layer, the measuring device supports the following features:

- IO-Link specification: version 1.1
- IO-Link Smart Sensor Profile 2nd Edition (supports minimum scope of IdentClass)
- SIO mode: Yes
- Speed: COM2; 38.4 kBaud
- Minimum cycle time: 2.5 msec.
- Process data width: 32 bit
- IO-Link data storage: Yes
- Block configuration: Yes

IO-Link download

<http://www.endress.com/download>

- Select "Software" as the media type.
- Select "Device Driver" as the software type.
Select IO-Link (IODD).
- In the "Text Search" field enter the device name.

<https://ioddfinder.io-link.com/>

Search by

- Manufacturer
- Article number
- Product type

Switch output

Behavior of switch output

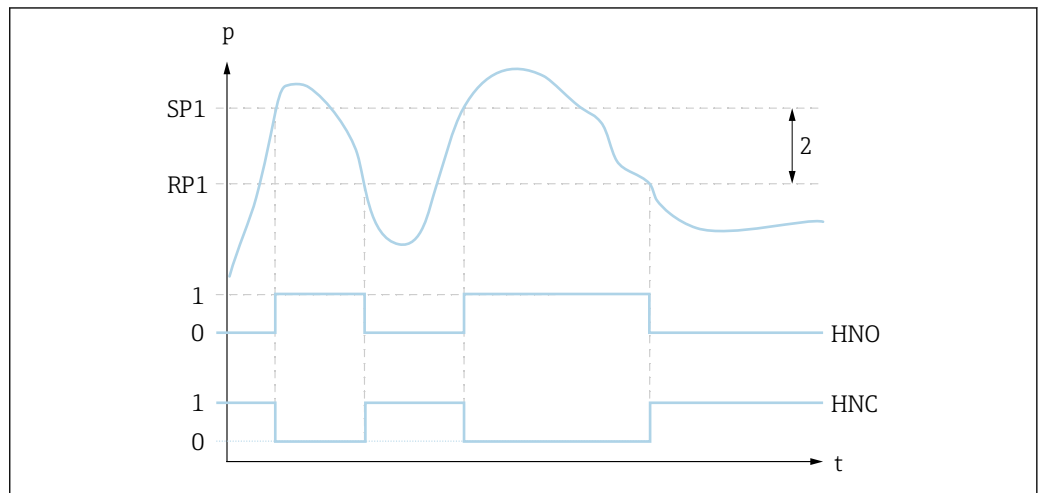

- 0 0-signal. Output open in quiescent state
- 1 1-signal. Output closed in quiescent state
- 2 Hysteresis
- SP1 Switch point
- RP1 Switchback point
- HNO NO contact
- HNC NC contact

A0034025

Plug-on display PHX20 (optional)

Devices with valve plug can be fitted with the optional local display PHX20.

Designation	Option ¹⁾
Plug-on display PHX20, IP65	RU

1) Product Configurator, order code for "Accessories"

A 1-line liquid crystal display (LCD) is used. The local display shows measured values, fault messages and information messages. The device display can be turned in 90° steps. Depending on the orientation of the device, it is therefore easy to read the measured values.

Technical data

Display:	4-digit, red LED display
Digit height:	7.62 mm; programmable decimal point setting
Display range:	-1999...9999
Accuracy:	0.2% of span ±1 digit
Electrical connection:	to transmitter with 4 to 20 mA output and elbow plug DIN 43 650, with reverse polarity protection
Power supply for display:	not required, self-powered by the current loop
Voltage drop:	≤ 5 V (corresponds to load: max. 250 Ω)
Conversion rate:	3 measurements per second
Damping:	0.3 to 20 s (configurable)
Data backup:	non-volatile EEPROM
Error message:	<ul style="list-style-type: none"> ■ HI: Overranging ■ LO: Underranging
Programming:	via 2 buttons, menu-guided, scaling of display range, decimal point, damping, error message
Degree of protection:	IP 65

Effect of temperature on display:	0.1% / 10 K
Electromagnetic compatibility (EMC):	Interference emission as per EN 50081, interference immunity as per EN 50082
Permitted current load:	max. 60 mA
Ambient temperature:	0 to +60 °C (+32 to +140 °F)
Housing material:	Plastic Pa6 GF30, blue Front screen made of PMMA, red
Order number:	52022914

Device Search (IO-Link)

The Device Search parameter is used to uniquely identify the device during installation.

Certificates and approvals

CE mark The device meets the legal requirements of the relevant EC directives. Endress+Hauser confirms that the device has been successfully tested by applying the CE mark.

RoHS The measuring system complies with the substance restrictions of the Restriction on Hazardous Substances Directive 2011/65/EU (RoHS 2).

RCM-Tick marking The supplied product or measuring system meets the ACMA (Australian Communications and Media Authority) requirements for network integrity, interoperability, performance characteristics as well as health and safety regulations. Here, especially the regulatory arrangements for electromagnetic compatibility are met. The products are labelled with the RCM- Tick marking on the name plate.



A0029561

EAC conformity The PMP21 and PMP23 devices meet the legal requirements of the applicable EAC directives. These are listed in the corresponding EAC Declaration of Conformity along with the standards applied. Endress+Hauser confirms successful testing of the device by affixing to it the EAC mark.

Approval CSA C/US General Purpose

Safety Instructions (XA) Depending on the approval, the following Safety Instructions (XA) are supplied with the device. They are an integral part of the Operating Instructions.

Device	Directive	Documentation	Option ¹⁾
PMP23	ATEX II 1/2G Ex ia IIC T4 Ga/Gb	XA01271P	BA
PMP23	FM IS Cl. I, Div.1 Gr. A-D T4	XA01321P	FA
PMP23	CSA C/US IS Cl. I Div. 1 Gr. A-D	XA01322P	CB
PMP23	EAC Ex ia IIC T4 Ga/Gb	XA01540P	GA
PMP23	IEC Ex ia IIC T4 Ga/Gb	XA01271P	IA
PMP23	NEPSI Ex ia IIC T4	XA01363P	NA
PMP23	JPN Ex ia IIC T4	In preparation	TA

1) Product Configurator, order code for "Approval"

 The nameplate indicates the Safety Instructions (XA) that are relevant to the device.

Suitability for hygienic processes All materials in contact with foodstuffs comply with framework regulation (EC) 1935/2004. The device is available with hygienic process connections (overview: see order code).

⚠ CAUTION**Contamination in the process!**

Risk of contamination if incorrect seals and parts are used!

- ▶ To avoid the risk of contamination, when installing the device comply with the design principles of EHEDG, Guideline 37 "Hygienic Design and Application of Sensors" and Guideline 16 "Hygienic Pipe Couplings".
- ▶ Suitable assemblies and seals must be used to ensure hygienic design in accordance with 3-A SSI and EHEDG specifications.
- ▶ The leak-proof connections can be cleaned with the cleaning methods typical of this industry (CIP and SIP). Attention must be paid to the pressure and temperature specifications of the sensor and process connections for CIP and SIP processes (clean in place/sterilize in place).

i The seamless connections can be cleaned of all residue using any of the typical cleaning methods within this industry.

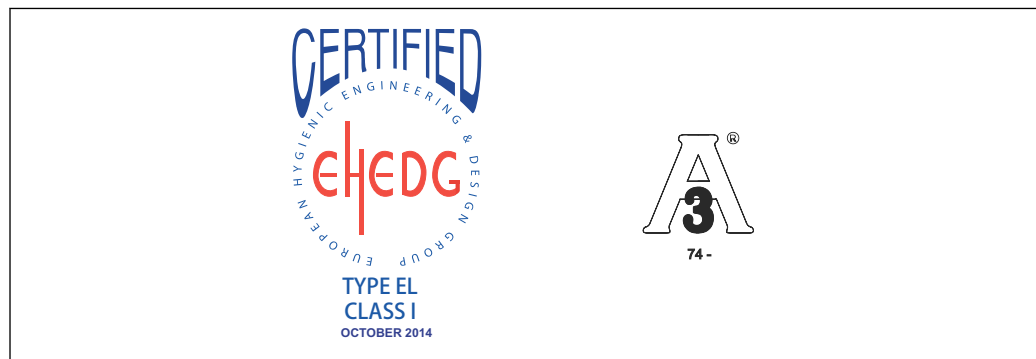

A0025304

Pressure Equipment Directive 2014/68/EU (PED)
Pressure equipment with allowable pressure ≤ 200 bar (2 900 psi)

Pressure equipment (with a maximum allowable pressure $PS \leq 200$ bar (2 900 psi)) can be classified as pressure accessories in accordance with Pressure Equipment Directive 2014/68/EU. If the maximum allowable pressure is ≤ 200 bar (2 900 psi) and the pressurized volume of the pressure equipment is ≤ 0.1 l, the pressure equipment is subject to the Pressure Equipment Directive (cf. Pressure Equipment Directive 2014/68/EU, Article 4, point 3). The Pressure Equipment Directive only requires that the pressure equipment shall be designed and manufactured in accordance with the "sound engineering practice of a Member State".

Reasons:

- Pressure Equipment Directive (PED) 2014/68/EU Article 4, point 3
- Pressure equipment directive 2014/68/EU, Commission's Working Group "Pressure", Guideline A-05 + A-06

Note:

A partial examination shall be performed for pressure instruments that are part of safety equipment for the protection of a pipe or vessel from exceeding allowable limits (safety accessory in accordance with Pressure Equipment Directive 2014/68/EU, Article 2, point 4).

Manufacturer declarations

Depending on the desired configuration, the following documents can be ordered additionally with the device:

- FDA conformity
- TSE-free: materials free from animal origin
- Regulation (EC) No. 2023/2006 (GMP)
- Regulation (EC) No. 1935/2004 on materials and articles intended to come into contact with food

Downloading the Declaration of Conformity

www.endress.com → Download

Other standards and guidelines

The applicable European guidelines and standards can be found in the relevant EU Declarations of Conformity. The following standards were also applied:

DIN EN 60770 (IEC 60770):

Transmitters for use in industrial process control systems Part 1: Methods for performance evaluation

Methods for evaluating the performance of transmitters for control and regulation in industrial process control systems.

DIN 16086:

Electrical pressure measuring instruments, pressure sensors, pressure transmitters, pressure measuring instruments, concepts, specifications on data sheets

Procedure for writing specifications in data sheets for electrical pressure measuring instruments, pressure sensors and pressure transmitters.

EN 61326-X:

EMC product family standard for electrical equipment for measurement, control and laboratory use.

EN 60529:

Degrees of protection provided by enclosures (IP code)

NAMUR - User association of automation technology in process industries.

NE21 - Electromagnetic Compatibility (EMC) of Industrial Process and Laboratory Control Equipment.

NE43 - Standardization of the Signal Level for the Failure Information of Digital Transmitters.

NE44 - Standardization of Status Indicators on PCT Instruments with the Help of Light Emitting Diodes

NE53 - Software of Field Devices and Signal-processing Devices with Digital Electronics

CRN approval

A CRN approval is available for some device versions. A CRN-approved process connection with a CSA approval must be ordered for a CRN-approved device. The CRN-approved devices are assigned the registration number OF18141.5C.

Ordering information: Product Configurator, order code for "Process connection" (the CRN process connections are indicated appropriately in the "Mechanical construction" section.)

Calibration unit

Designation	Option ¹⁾
Sensor range; %	A
Sensor range; mbar/bar	B
Sensor range; kPa/MPa	C
Sensor range; psi	F
Customer-specific; see additional spec.	J

1) Product Configurator, order code for "Calibration; unit"

Calibration

Designation	Option ¹⁾
3-point calibration certificate ²⁾	F3

1) Product Configurator, order code for "Calibration"

2) No final test report for PNP outputs.

Inspection certificates

Device	Designation	Option ¹⁾
PMP23	3.1 Material documentation, wetted metal parts, EN10204-3.1 inspection certificate	JA
PMP23	Surface finish measurement ISO4287/Ra, wetted metal parts, inspection certificate	KB

1) Product Configurator, order code for "Test, Certificate"

Additional approval

Device	Designation	Option ¹⁾
PMP23	EHEDG, certificate copy	L1
PMP23	3A, certificate copy	L2
PMP23	Declaration of Conformity EC1935/2004, wetted parts	L3

1) Product Configurator, order code for "Additional approval"

Ordering information

Detailed ordering information is available from the following sources:

- In the Product Configurator on the Endress+Hauser website: www.endress.com -> Click "Corporate" -> Select your country -> Click "Products" -> Select the product using the filters and search field -> Open product page -> The "Configure" button to the right of the product image opens the Product Configurator.
- From your Endress+Hauser Sales Center: www.addresses.endress.com



Product Configurator - the tool for individual product configuration

- Up-to-the-minute configuration data
- Depending on the device: Direct input of measuring point-specific information such as measuring range or operating language
- Automatic verification of exclusion criteria
- Automatic creation of the order code and its breakdown in PDF or Excel output format
- Ability to order directly in the Endress+Hauser Online Shop

Scope of delivery

- Measuring device
- Optional accessories
- Brief Operating Instructions
- Certificates

Accessories

Weld-in adapter

Various weld-in adapters are available for installation in vessels or pipes.

Device	Description	Option ¹⁾	Order number
PMP23	Weld-in adapter M24, d=65, 316L	PM	71041381
PMP23	Weld-in adapter M24, d=65, 316L 3.1 EN10204-3.1 material, inspection certificate	PN	71041383
PMP23	Weld-in adapter G1, 316L, conical metal joint	QE	52005087
PMP23	Weld-in adapter G1, 316L, 3.1, conical metal joint, EN10204-3.1 material, inspection certificate	QF	52010171
PMP23	Weld-in tool adapter G1, brass	QG	52005272
PMP23	Weld-in adapter G1, 316L, silicone O-ring seal	QJ	52001051
PMP23	Weld-in adapter G1, 316L, 3.1, silicone O-ring seal, EN10204-3.1 material, inspection certificate	QK	52011896
PMP23	Weld-in adapter Uni D65, 316L	QL	214880-0002
PMP23	Weld-in adapter Uni D65, 316L 3.1 EN10204-3.1 material, inspection certificate	QM	52010174
PMP23	Weld-in tool adapter Uni D65/D85, brass	QN	71114210
PMP23	Weld-in adapter Uni D85, 316L	QP	52006262
PMP23	Weld-in adapter Uni D85, 316L 3.1 EN10204-3.1 material, inspection certificate	QR	52010173

1) Product Configurator, order code for "Enclosed accessories"

If installed horizontally and weld-in adapters with a leakage hole are used, ensure that the leakage hole is pointing down. This allows leaks to be detected as quickly as possible.

Process adapter M24

The following process adapters can be ordered for the process connections with order option X2J and X3J:

Device	Description	Order number	Order number with inspection certificate 3.1 EN10204
PMP23	Varivent F DN32 PN40	52023996	52024003
PMP23	Varivent N DN50 PN40	52023997	52024004
PMP23	DIN11851 DN40	52023999	52024006
PMP23	DIN11851 DN50	52023998	52024005
PMP23	SMS 1½"	52026997	52026999
PMP23	Clamp 1½"	52023994	52024001
PMP23	Clamp 2"	52023995	52024002

Plug-on display PHX20

→  31

M12 plug connectors

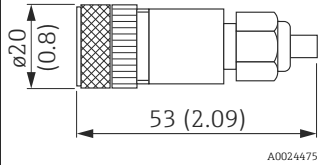
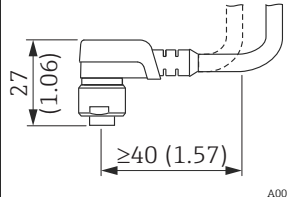
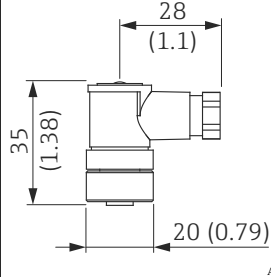
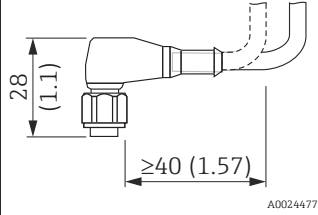
Connector	Degree of protection	Material	Option ¹⁾	Order number
M12 (self-terminated connection at M12 plug) 	IP67	<ul style="list-style-type: none"> ▪ Union nut: Cu Sn/Ni ▪ Body: PBT ▪ Seal: NBR 	R1	52006263
M12 90 degrees with 5m (16 ft) cable 	IP67	<ul style="list-style-type: none"> ▪ Union nut: GD Zn/Ni ▪ Body: PUR ▪ Cable: PVC Cable colors <ul style="list-style-type: none"> ▪ 1 = BN = brown ▪ 2 = WT = white ▪ 3 = BU = blue ▪ 4 = BK = black 	RZ	52010285
M12 90 degrees (self-terminated connection at M12 plug) 	IP67	<ul style="list-style-type: none"> ▪ Union nut: GD Zn/Ni ▪ Body: PBT ▪ Seal: NBR 	RM	71114212
M12 90 degrees with 5m (16 ft) cable (terminated at one end) 	IP69 ²⁾	<ul style="list-style-type: none"> ▪ Union nut: 316L (1.4435) ▪ Body and cable: PVC and PUR 	RW	52024216

- 1) Product Configurator, order code for "Enclosed accessories"
- 2) Designation of the IP protection class according to DIN EN 60529. Previous designation "IP69K" according to DIN 40050 Part 9 is no longer valid (standard withdrawn on November 1, 2012). The tests required by both standards are identical.

Supplementary documentation

Field of Activities	Pressure measurement, powerful instruments for process pressure, differential pressure, level and flow: FA00004P
Technical Information	<ul style="list-style-type: none"> ■ TI00241F: EMC Test Procedures ■ TI00426F: Weld-in adapters, process adapters and flanges (overview)
Operating Instructions	BA01271P BA01784P (devices with IO-Link)
Brief Operating Instructions	KA01164P (not for devices with IO-Link)
Safety Instructions (XA)	Depending on the approval, the following Safety Instructions (XA) are supplied with the device. They are an integral part of the Operating Instructions.

Device	Directive	Documentation	Option ¹⁾
PMP23	ATEX II 1/2G Ex ia IIC T4 Ga/Gb	XA01271P	BA
PMP23	FM IS Cl. I, Div.1 Gr. A-D T4	XA01321P	FA
PMP23	CSA C/US IS Cl. I Div. 1 Gr. A-D	XA01322P	CB
PMP23	EAC Ex ia IIC T4 Ga/Gb	XA01540P	GA
PMP23	IEC Ex ia IIC T4 Ga/Gb	XA01271P	IA
PMP23	NEPSI Ex ia IIC T4	XA01363P	NA
PMP23	JPN Ex ia IIC T4	In preparation	TA

1) Product Configurator, order code for "Approval"



The nameplate indicates the Safety Instructions (XA) that are relevant to the device.

Registered trademarks

 **IO-Link**

is a registered trademark of the IO-Link company group.



www.addresses.endress.com
