

# Brief Operating Instructions

## Deltabar S

### PMD75, FMD77, FMD78

Differential pressure measurement

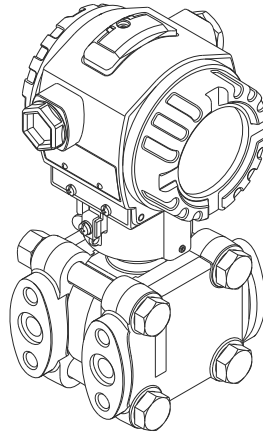

These Instructions are Brief Operating Instructions; they are not a substitute for the Operating Instructions pertaining to the device.

Detailed information about the device can be found in the Operating Instructions and the other documentation:

Available for all device versions via:

- Internet: [www.endress.com/deviceviewer](http://www.endress.com/deviceviewer)
- Smart phone/tablet: *Endress+Hauser Operations App*

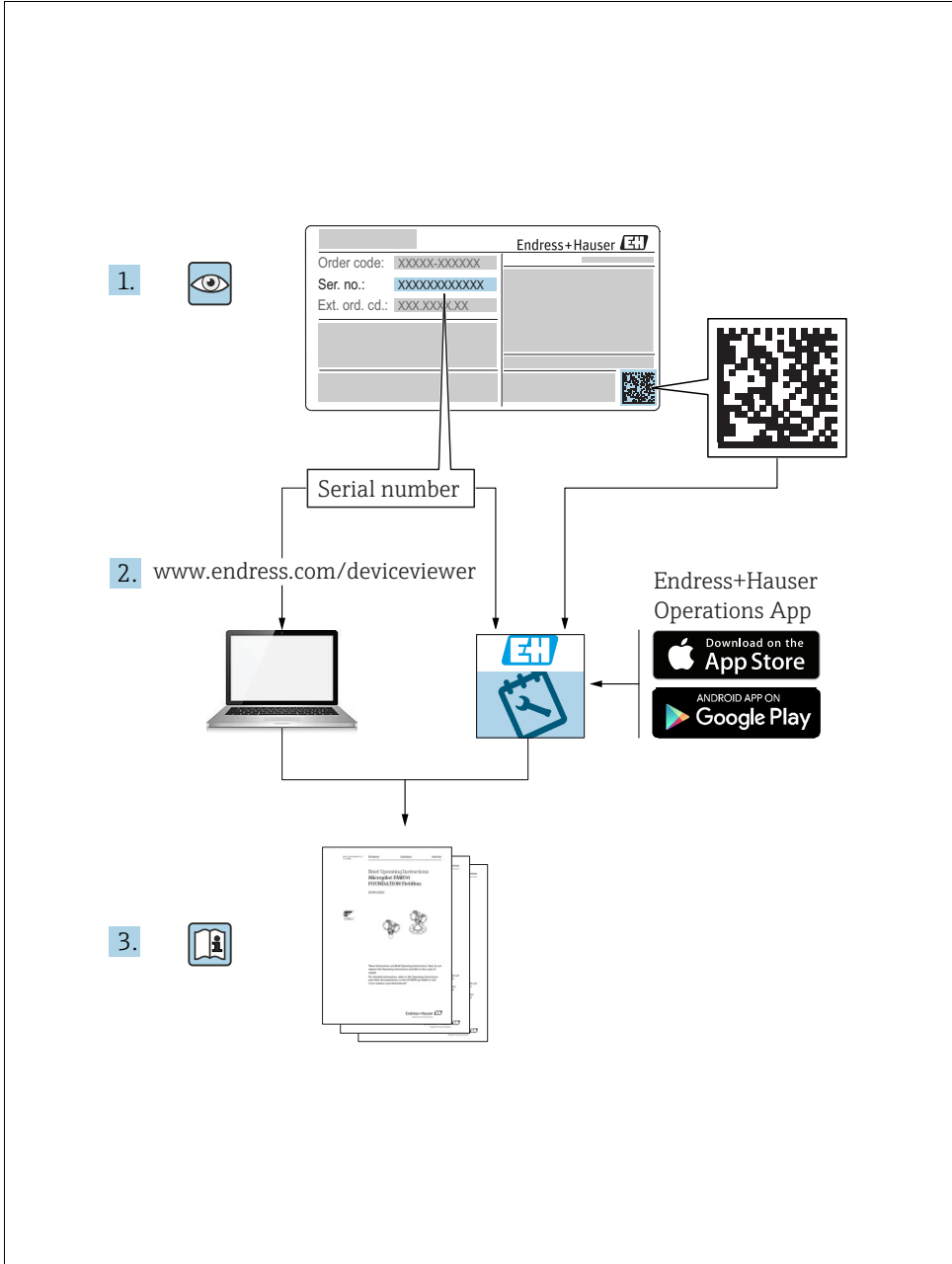

# Table of contents

1	Document information	4
1.1	Document function	4
1.2	Symbols used	4
1.3	Registered trademarks	6
1.4	Terms and abbreviations	7
1.5	Turn down calculation	8
2	Basic safety instructions	9
2.1	Requirements concerning the staff	9
2.2	Designated use	9
2.3	Workplace safety	9
2.4	Operational safety	9
2.5	Hazardous area	10
2.6	Product safety	10
3	Identification	10
3.1	Product identification	10
3.2	Device designation	11
3.3	Scope of delivery	11
3.4	CE mark, Declaration of Conformity	12
3.5	Registered trademarks	12
4	Installation	13
4.1	Incoming acceptance and storage	13
4.2	Installation conditions	14
4.3	Installation instructions	14
4.4	Post-installation check	21
5	Wiring	22
5.1	Connecting the device	22
5.2	Connecting the measuring unit	23
5.3	Overvoltage protection (optional)	24
5.4	Post-connection check	24
6	Operation	25
6.1	Onsite display (optional)	25
6.2	Operating elements	27
6.3	FOUNDATION Fieldbus interface	30
6.4	Local operation – onsite display connected	31
6.5	HistoROM®/M-DAT (optional)	35
6.6	FieldCare	35
6.7	Locking/unlocking operation	35
6.8	Simulation	36
6.9	Factory setting (reset)	36
7	Commissioning	36
7.1	Configuring messages	36
7.2	Function check	36
7.3	Commissioning via an FF configuration program	37
7.4	Selecting the language and measuring mode	37
7.5	Position adjustment	37
7.6	Flow measurement	38
7.7	Level measurement	42
7.8	Differential pressure measurement	48
7.9	Scaling the OUT parameter	51





# 1 Document information

## 1.1 Document function







These Operating Instructions contain all the information that is required in various phases of the life cycle of the device: from product identification, incoming acceptance and storage, to mounting, connection, operation and commissioning through to troubleshooting, maintenance and disposal.

## 1.2 Symbols used



### 1.2.1 Safety symbols

Symbol	Meaning
 A0011189-DE	<b>DANGER!</b> This symbol alerts you to a dangerous situation. Failure to avoid this situation will result in serious or fatal injury.
 A0011190-DE	<b>WARNING!</b> This symbol alerts you to a dangerous situation. Failure to avoid this situation can result in serious or fatal injury.
 A0011191-DE	<b>CAUTION!</b> This symbol alerts you to a dangerous situation. Failure to avoid this situation can result in minor or medium injury.
 A0011192-DE	<b>NOTICE!</b> This symbol contains information on procedures and other facts which do not result in personal injury.









### 1.2.2 Electrical symbols

Symbol	Meaning	Symbol	Meaning
	Direct current		Alternating current
	Direct current and alternating current		<b>Ground connection</b> A grounded terminal which, as far as the operator is concerned, is grounded via a grounding system.
	<b>Protective ground connection</b> A terminal which must be connected to ground prior to establishing any other connections.		<b>Equipotential connection</b> A connection that has to be connected to the plant grounding system. This may be a potential equalization line or a star grounding system depending on national or company codes of practice.

### 1.2.3 Tool symbols

Symbol	Meaning
 A0011221	Allen key
 A0011222	Hexagon wrench

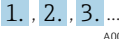
### 1.2.4 Symbols for certain types of information

Symbol	Meaning
 A0011182	<b>Permitted</b> Indicates procedures, processes or actions that are permitted.
 A0011184	<b>Forbidden</b> Indicates procedures, processes or actions that are forbidden.
 A0011193	<b>Tip</b> Indicates additional information.
 A0015482	Reference to documentation
 A0015484	Reference to page
 A0015487	Reference to graphic
 A0031595	Series of steps
 A0018343	Result of a sequence of actions
 A0015502	Visual inspection

### 1.2.5 Symbols in graphics

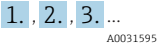
Symbol	Meaning
1, 2, 3, 4, ...	Item numbers
	Series of steps
A, B, C, D, ...	Views

### 1.2.6 Symbols at the device

Symbol	Meaning
	<b>Safety instructions</b> Observe the safety instructions contained in the associated Operating Instructions.

## 1.3 Registered trademarks

KALREZ, VITON, TEFLON

Registered trademarks of E.I. Du Pont de Nemours & Co., Wilmington, USA

TRI-CLAMP

Registered trademark of Ladish & Co., Inc., Kenosha, USA

FOUNDATION™ Fieldbus

Registered trademark of the FieldComm Group, Austin, USA

GORE-TEX®

Registered trademarks of W.L. Gore & Associates, Inc., USA

## 1.4 Terms and abbreviations

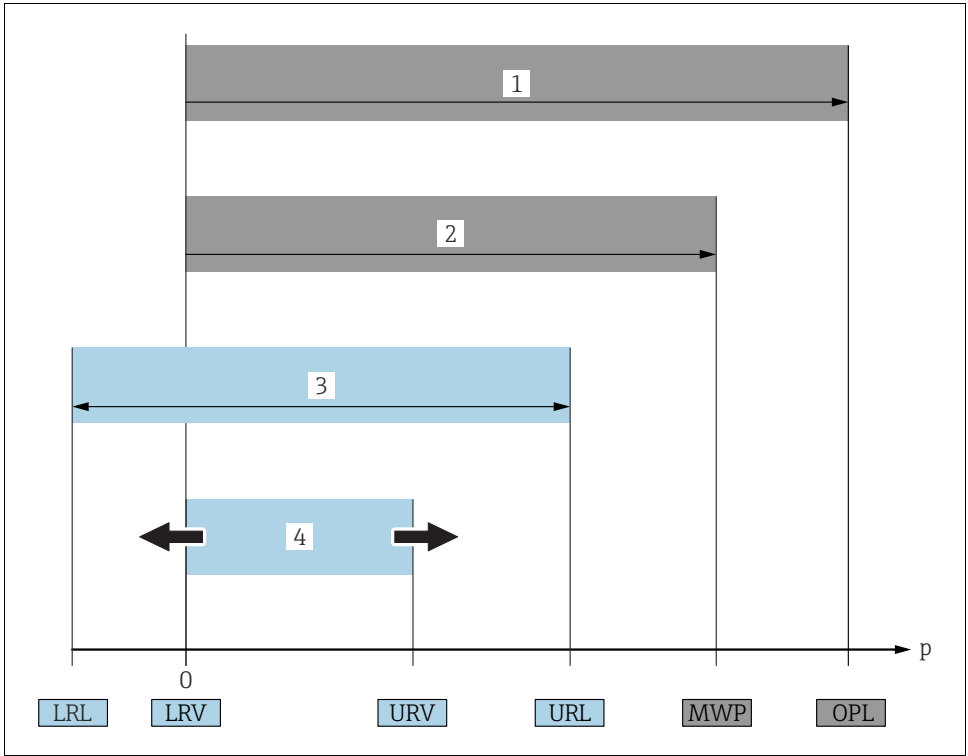

A0029505

Position	Term/Abbreviation	Explanation
1	OPL	The OPL (over pressure limit = sensor overload limit) for the sensors depends on the lowest-rated element, with regard to pressure, of the selected components, i.e. the process connection must be taken into consideration in addition to the measuring cell. Also observe pressure-temperature dependency. For the relevant standards and additional notes, see technical information. The OPL may be applied for a limited time period.
2	MWP	The MWP (maximum working pressure) for the sensors depends on the lowest-rated element, with regard to pressure, of the selected components, i.e. the process connection has to be taken into consideration in addition to the measuring cell. Also observe pressure-temperature dependency. For the relevant standards and additional notes, see technical information. The MWP may be applied for an unlimited time.
3	Maximum sensor measuring range	Range between LRL and URL. This span is the maximum calibratable/adjustable measuring span.

Position	Term/Abbreviation	Explanation
4	Calibrated/Adjusted measuring span	Range between LRV and URV Factory setting: 0...URL Other calibrated spans can be ordered with customised settings.
p	-	Pressure
-	LRL	Lower range limit
-	URL	Upper range limit
-	LRV	Lower range value
-	URV	Upper range value
-	TD	Turn down

### 1.5 Turn down calculation

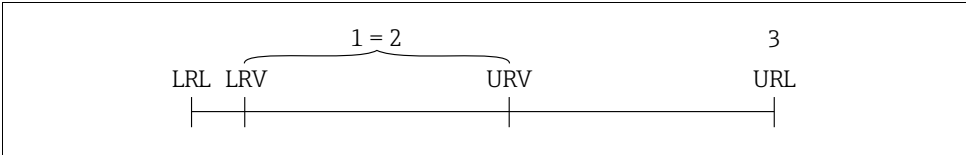

A0029545

Fig. 1:

- 1 Calibrated/Adjusted measuring span
- 2 Zero-based span
- 3 Upper range limit

Example	
<ul style="list-style-type: none"> <li>▪ Sensor: 10 bar (150 psi)</li> <li>▪ Upper range limit (URL) = 10 bar (150 psi)</li> </ul> <p>Turn down (TD):</p> $TD = \frac{URL}{ URV - LRV }$ $TD = \frac{10 \text{ bar (150 psi)}}{ 5 \text{ bar (75 psi)} - 0 \text{ bar (0 psi)} } = 2$ <p>In this example, the TD is thus 2:1. This span is based on the zero point.</p>	<ul style="list-style-type: none"> <li>▪ Calibrated/Adjusted measuring span: 0...5 bar (0...75 psi)</li> <li>▪ Lower range value (LRV) = 0 bar</li> <li>▪ Upper range value (URV) = 5 bar (75 psi)</li> </ul>



## 2 Basic safety instructions

### 2.1 Requirements concerning the staff

The personnel for installation, commissioning, diagnostics and maintenance must fulfill the following requirements:

- Trained, qualified specialists: must have a relevant qualification for this specific function and task
- Are authorized by the plant owner/operator
- Are familiar with federal/national regulations
- Before beginning work, the specialist staff must have read and understood the instructions in the Operating Instructions and supplementary documentation as well as in the certificates (depending on the application)
- Following instructions and basic conditions

The operating personnel must fulfill the following requirements:

- Being instructed and authorized according to the requirements of the task by the facility's owner-operator
- Following the instructions in these Operating Instructions

### 2.2 Designated use

The Deltabar S is a differential pressure transmitter for measuring differential pressure, flow and level.

#### 2.2.1 Incorrect use

The manufacturer is not liable for damage caused by improper or non-designated use.

Verification for borderline cases:

For special fluids and fluids for cleaning, Endress+Hauser is glad to provide assistance in verifying the corrosion resistance of fluid-wetted materials, but does not accept any warranty or liability.

### 2.3 Workplace safety

For work on and with the device:

- Wear the required personal protective equipment according to federal/national regulations.
- Switch off the supply voltage before connecting the device.

### 2.4 Operational safety

Risk of injury!

- ▶ Operate the device in proper technical condition and fail-safe condition only.
- ▶ The operator is responsible for interference-free operation of the device.

## Conversions to the device

Unauthorized modifications to the device are not permitted and can lead to unforeseeable dangers:

- ▶ If, despite this, modifications are required, consult with Endress+Hauser.

## Repair

To ensure continued operational safety and reliability,

- ▶ Carry out repairs on the device only if they are expressly permitted.
- ▶ Observe federal/national regulations pertaining to repair of an electrical device.
- ▶ Use original spare parts and accessories from Endress+Hauser only.

## 2.5 Hazardous area

To eliminate a danger for persons or for the facility when the device is used in the hazardous area (e.g. explosion protection, pressure vessel safety):

- Based on the nameplate, check whether the ordered device is permitted for the intended use in the hazardous area.
- Observe the specifications in the separate supplementary documentation that is an integral part of these Instructions.

## 2.6 Product safety

This measuring device is designed in accordance with good engineering practice to meet state-of-the-art safety requirements, has been tested, and left the factory in a condition in which they are safe to operate. It fulfills general safety requirements and legal requirements. It also conforms to the EC directives listed in the device-specific EC declaration of conformity. Endress+Hauser confirms this fact by applying the CE mark.

# 3 Identification

## 3.1 Product identification

The following options are available for identification of the measuring device:

- Nameplate specifications
- Order code with breakdown of the device features on the delivery note
- Enter serial numbers from nameplates in W@M Device Viewer ([www.endress.com/deviceviewer](http://www.endress.com/deviceviewer)): All information about the measuring device is displayed.

For an overview of the technical documentation provided, enter the serial number from the nameplates in the W@M Device Viewer ([www.endress.com/deviceviewer](http://www.endress.com/deviceviewer)).

## 3.2 Device designation

### 3.2.1 Nameplates

- The MWP (maximum working pressure) is specified on the nameplate. This value refers to a reference temperature of +20 °C (68°F) and may be applied to the device for an unlimited time. Observe temperature dependency of the MWP. The pressure values permitted at higher temperatures can be found in the standards EN 1092-1: 2001 Tab. 18 (With regard to their stability-temperature property, the materials 1.4435 and 1.4404 are grouped together under 13EO in EN 1092-1 Tab. 18. The chemical composition of the two materials can be identical.), ASME B 16.5a – 1998 Tab. 2-2.2 F316, ASME B 16.5a – 1998 Tab. 2.3.8 N10276, JIS B 2220.
- For PMD75, the MWP applies for the temperature ranges specified in the Technical Information TI00382P in the "Ambient temperature range" and "Process temperature limits" sections.
- The test pressure corresponds to the over pressure limit (OPL) of the device = MWP x 1.5.
- The Pressure Equipment Directive (2014/68/EU) uses the abbreviation "PS". The abbreviation "PS" corresponds to the MWP (maximum working pressure) of the measuring device.

### 3.2.2 Identifying the sensor type

See parameter "Sensor Meas.Type" in Operating Instruction BA00303P.

## 3.3 Scope of delivery

The scope of delivery comprises:

- Deltabar S differential pressure transmitter
- For PMD75 with side flanges made of AISI 316L or C22.8: additionally 2 vent valves, AISI 316L
- PMD75 with side flanges made of AISI 316L or C22.8 and side vent: additionally 4 locking screws, AISI 316L
- For devices with the "HistoROM/M-DAT" option: CD-ROM with Endress+Hauser operating program
- Optional accessories

Documentation supplied:

- Operating Instructions BA00301P and BA00303P are available via the Internet.  
→ See: [www.endress.com](http://www.endress.com) → Download.
- Brief Operating Instructions KA01024P
- Fold-out brochure KA00252P
- Final inspection report
- Additional Safety Instructions with ATEX, IECEx and NEPSI devices
- Optional: factory calibration form, test certificates

### **3.4 CE mark, Declaration of Conformity**

The devices are designed to meet state-of-the-art safety requirements, have been tested and left the factory in a condition in which they are safe to operate. The devices comply with the applicable standards and regulations as listed in the EC Declaration of Conformity and thus comply with the statutory requirements of the EC Directives. Endress+Hauser confirms the conformity of the device by affixing to it the CE mark.

### **3.5 Registered trademarks**

KALREZ, VITON, TEFLON

Registered trademarks of E.I. Du Pont de Nemours & Co., Wilmington, USA

TRI-CLAMP

Registered trademark of Ladish & Co., Inc., Kenosha, USA

FOUNDATION™ Fieldbus

Registered trademark of the Fieldbus Foundation Austin, Texas, USA

## 4 Installation

### NOTICE

#### Incorrect handling!

Damage of the device!

- ▶ Disassembly of the screws with item number (1) is not permissible under any circumstances and will result in loss of warranty.

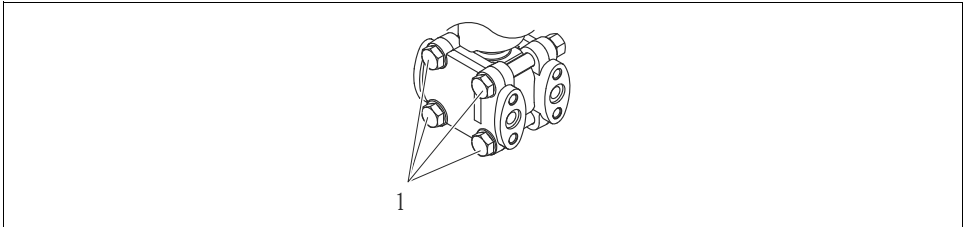

A0025336

### 4.1 Incoming acceptance and storage

#### 4.1.1 Incoming acceptance

- Check the packaging and the contents for damage.
- Check the shipment, make sure nothing is missing and that the scope of supply matches your order.

#### 4.1.2 Transport

### ▲ WARNING

#### Incorrect transport

Housing and diaphragm may be damaged and there is a risk of injury!

- ▶ Transport the measuring device to the measuring point in its original packaging or by the process connection (with secure transport protection for the diaphragm).
- ▶ Follow the safety instructions and transport conditions for devices of more than 18 kg (39.69 lbs).
- ▶ Do not use capillaries as a carrying aid for the diaphragm seals.

#### 4.1.3 Storage

The device must be stored in a dry, clean area and protected against impact (EN 837-2).

Storage temperature range:

- -40 to +90°C (-40 to +194 °F)
- Onsite display: -40 to +85°C (-40 to +185°F)
- Separate housing: -40 to +60°C (-40 to +140°F)

## 4.2 Installation conditions

### 4.2.1 Dimensions

→ For dimensions, please refer to the Technical Information for Deltabar S TI00382P, "Mechanical construction" section.

## 4.3 Installation instructions

- Due to the orientation of the Deltabar S, there may be a shift in the measured value, i.e. when the container is empty or partially full, the measured value does not display zero. You can correct this zero point shift using the "Zero" key on the electronic insert or externally on the device or via the onsite display. → [Figure 27](#), Section 6.2.1 "Position of the operating elements", → [Figure 29](#), Section 6.2.3 "Function of the operating elements – onsite display connected" and → [Figure 37](#), Section 7.5 "Position adjustment"..
- For FMD77 and FMD78, please refer to Section 4.3.4 "Installation instructions for devices with diaphragm seals (FMD78)", → [Figure 16](#).
- General recommendations for routing the pressure piping can be found in DIN 19210 "Methods for measurement of fluid flow; differential piping for flow measurement devices" or the corresponding national or international standards.
- Using a three-way or five-way valve manifold allows for easy commissioning, installation and maintenance without interrupting the process.
- When routing the pressure piping outdoors, ensure that sufficient antifreeze protection is used, e.g. by using pipe heat tracing.
- Install the pressure piping with a monotonic gradient of at least 10%.
- To ensure optimal readability of the onsite display, it is possible to rotate the housing up to 380°. → [Figure 20](#), Section 4.3.9 "Rotating the housing".
- Endress+Hauser offers a mounting bracket for installing on pipes or walls. → [Figure 18](#), Section 4.3.7 "Wall and pipe-mounting (optional)".

### 4.3.1 Installation for flow measurement

#### Flow measurement in gases with PMD75

- Mount the Deltabar S above the measuring point so that the condensate can run off into the process piping.

#### Flow measurement in steam with PMD75

- Mount the Deltabar S below the measuring point.
- Mount the condensate traps at the same level as the tapping points and at the same distance to the Deltabar S.
- Prior to commissioning, fill the pressure piping to the level of the condensate traps.

#### Flow measurement in liquids with PMD75

- Mount the Deltabar S below the measuring point so that the pressure piping is always filled with liquid and gas bubbles can run back into the process piping.

- When measuring in media with solid parts, such as dirty liquids, installing separators and drain valves is useful for capturing and removing sediment.

### 4.3.2 Installation for level measurement

#### Level measurement in an open container with PMD75

- Mount the Deltabar S below the lower measuring connection so that the pressure piping is always filled with liquid.
- The negative side is open to atmospheric pressure.
- When measuring in media with solid parts, such as dirty liquids, installing separators and drain valves is useful for capturing and removing sediment.

#### Level measurement in an open container with FMD77

- Mount the Deltabar S directly on the container. →  18, Section 4.3.5 "Seal for flange mounting".
- The negative side is open to atmospheric pressure.

#### Level measurement in a closed container with PMD75

- Mount the Deltabar S below the lower measuring connection so that the pressure piping is always filled with liquid.
- Always connect the impulse piping of negative side above the maximum level.
- When measuring in media with solid parts, such as dirty liquids, installing separators and drain valves is useful for capturing and removing sediment.

#### Level measurement in a closed container with FMD77

- Mount the Deltabar S directly on the container. →  18, Section 4.3.5 "Seal for flange mounting".
- Always connect the impulse piping of negative side above the maximum level.
- When measuring in media with solid parts, such as dirty liquids, installing separators and drain valves is useful for capturing and removing sediment.

#### Level measurement in a closed container with FMD78

- Mount the Deltabar S below the lower diaphragm seal. →  16, Section 4.3.4 "Installation instructions for devices with diaphragm seals (FMD78)".
- The ambient temperature should be the same for both capillaries.

Level measurement is only ensured between the upper edge of the lower diaphragm seal and the lower edge of the upper diaphragm seal.

#### Level measurement in a closed container with superimposed steam with PMD75

- Mount the Deltabar S below the lower measuring connection so that the pressure piping is always filled with liquid.
- Always connect the impulse piping of negative side above the maximum level.

- A condensate trap ensures constant pressure on the negative side.
- When measuring in media with solid parts, such as dirty liquids, installing separators and drain valves is useful for capturing and removing sediment.

### Level measurement in a closed container with superimposed steam with FMD77

- Mount the Deltabar S directly on the container. →  18, Section 4.3.5 "Seal for flange mounting".
- Always connect the impulse piping of negative side above the maximum level.
- A condensate trap ensures constant pressure on the negative side.
- When measuring in media with solid parts, such as dirty liquids, installing separators and drain valves is useful for capturing and removing sediment.

### 4.3.3 Installation for differential pressure measurement

#### Differential pressure measurement in gases and steam with PMD75

- Mount the Deltabar S above the measuring point so that the condensate can run off into the process piping.

#### Differential pressure measurement in liquids with PMD75

- Mount the Deltabar S below the measuring point so that the pressure piping is always filled with liquid and gas bubbles can run back into the process piping.
- When measuring in media with solid parts, such as dirty liquids, installing separators and drain valves is useful for capturing and removing sediment.

#### Differential pressure measurement in gases, steam and liquids with FMD78

- Mount the diaphragm seal with capillaries at the top or on the side on the piping.
- For vacuum applications: mount the Deltabar S below the measuring point. →  17, Section 4.3.4, "Vacuum application (FMD78)".
- The ambient temperature should be the same for both capillaries.

### 4.3.4 Installation instructions for devices with diaphragm seals (FMD78)

- Please note that the hydrostatic pressure of the liquid columns in the capillaries can cause zero point shift. The zero point shift can be corrected.
- Do not clean or touch the process isolating diaphragm of the diaphragm seal with hard or pointed objects.
- Do not remove process isolating diaphragm protection until shortly before installation.

#### **NOTICE**

##### **Improper handling!**

Damage to the device!

- ▶ A diaphragm seal and the pressure transmitter together form a closed, oil-filled calibrated system. The fill fluid hole is sealed and may not be opened.



- ▶ When using a mounting bracket, sufficient strain relief must be ensured for the capillaries in order to prevent the capillary bending down (bending radius  $\geq 100$  (3.94 in)).
- ▶ Please observe the application limits of the diaphragm seal filling oil as detailed in the Technical Information for Deltabar S TI00382P, "Planning instructions for diaphragm seal systems" section.

### NOTICE

**In order to obtain more precise measurement results and to avoid a defect in the device, mount the capillaries as follows:**

- ▶ Vibration-free (in order to avoid additional pressure fluctuations)
- ▶ Not in the vicinity of heating or cooling lines
- ▶ Insulate if the ambient temperature is below or above the reference temperature
- ▶ With a bending radius of  $\geq 100$  mm (3.94 in).
- ▶ Do not use the capillaries as a carrying aid for the diaphragm seals!
- ▶ The ambient temperature and length of both capillaries should be the same when using two-sided diaphragm seal systems.
- ▶ Two diaphragm seals which are the same (e.g. with regard to diameter, material, etc.) should always be used for the negative and positive side (standard delivery).

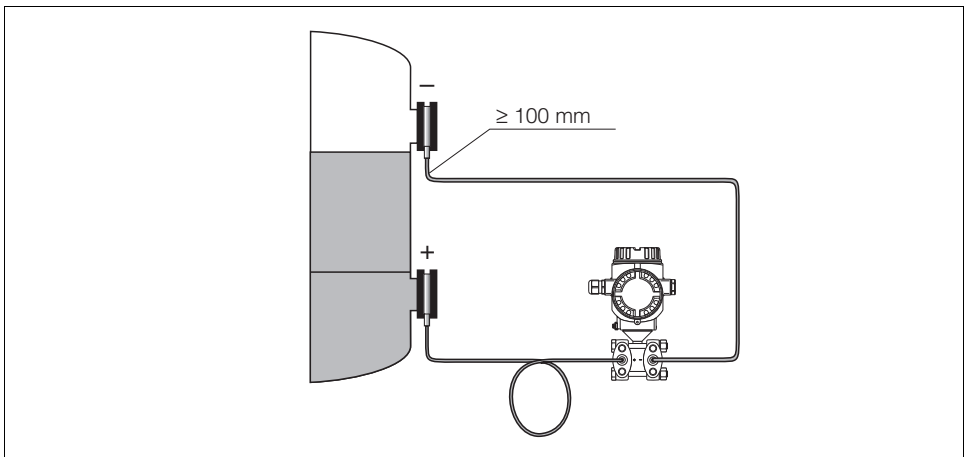

P01-FMD78xxxx-11-xx-xx-xx-005

Fig. 2: Mounting Deltabar S, FMD78 with diaphragm seals and capillaries, recommended mounting for vacuum applications: mount pressure transmitter below the lowest diaphragm seal!

### Vacuum application (FMD78)

See operating instructions.

### 4.3.5 Seal for flange mounting

#### NOTICE

#### Distorted measurement results.

The seal is not allowed to press on the process isolating diaphragm as this could affect the measurement result.

- Ensure that the seal is not touching the process isolating diaphragm.

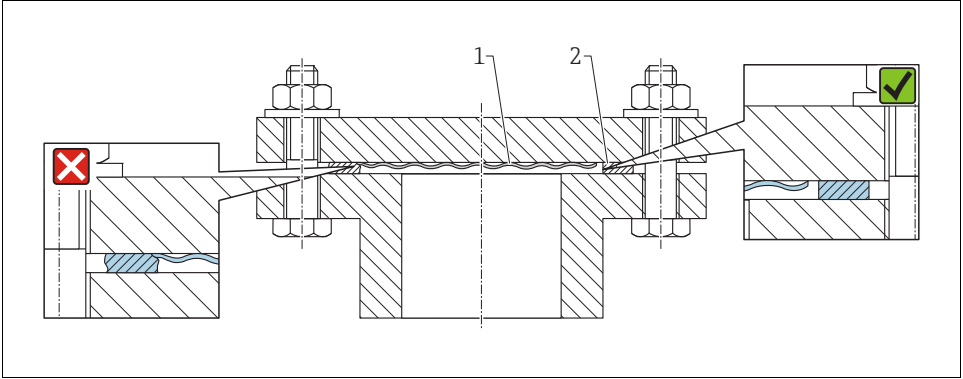

A0017743

Fig. 3:

- 1 Process isolating diaphragm  
2 Seal

### 4.3.6 Heat insulation – FMD77

See operating instructions.

### 4.3.7 Wall and pipe-mounting (optional)

Endress+Hauser offers the following mounting brackets for installing the device on pipes or walls:

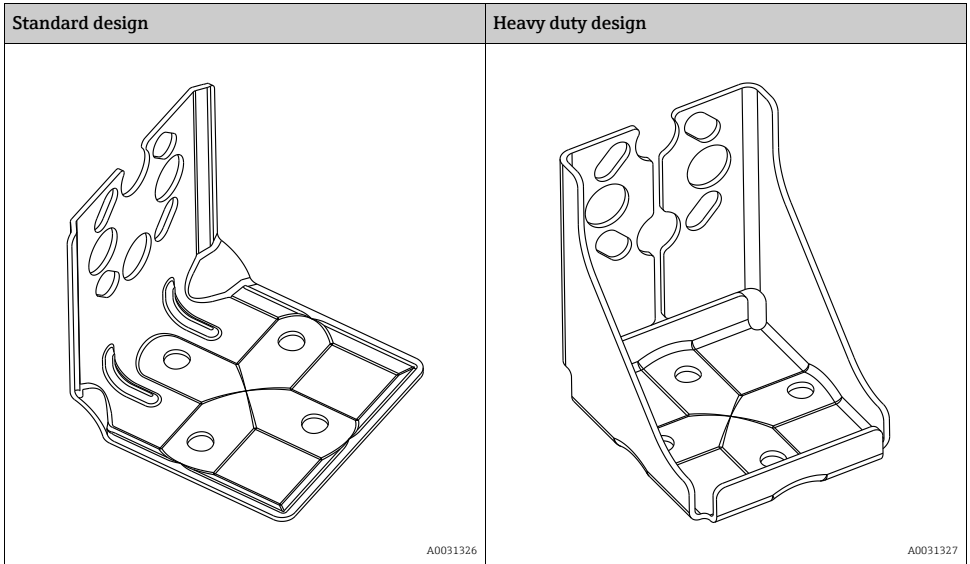

The standard mounting bracket version is not suitable for use in an application subject to vibrations.

The vibration resistance of the reinforced version of the mounting bracket has been tested according to IEC 61298-3, see the "Vibration resistance" section in the technical documentation TI00382P.



When using a valve block, the block's dimensions must be taken into account.

Bracket for wall and pipe mounting including retaining bracket for pipe mounting and two nuts. Material of the screws used to secure the device depend on the order code.

Technical data (e.g. dimensions or order numbers for screws) see accessory document SD01553P/00/EN.

### NOTICE

#### Incorrect handling!

Damage of the device!

- ▶ Disassembly of the screws with item number (1) is not permissible under any circumstances and will result in loss of warranty.

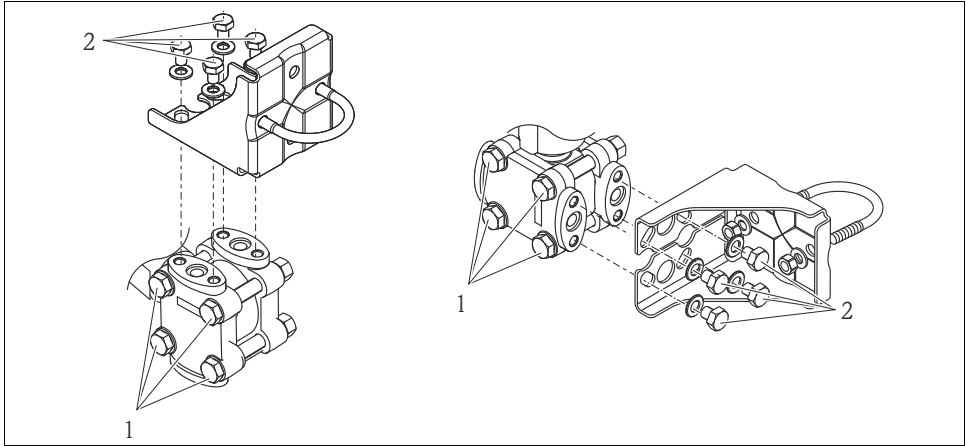

A0025335

#### 4.3.8 Assembling and mounting the "separate housing" version

See operating instructions.

#### 4.3.9 Rotating the housing

The housing can be rotated up to 380° by loosening the Allen screw.

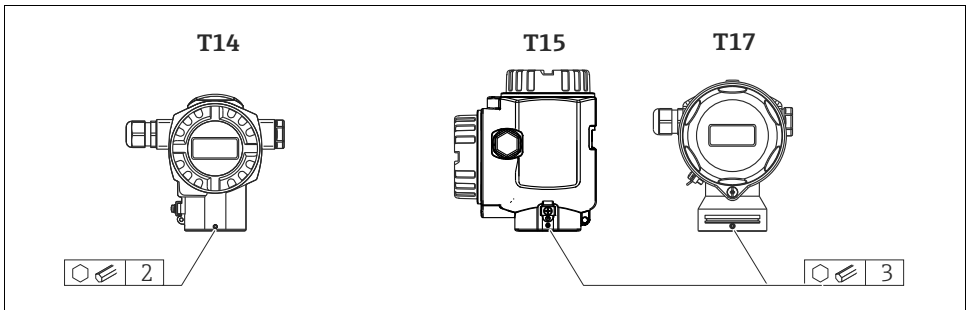

A0019996

1. T14 housing: Loosen setscrew with a 2 mm (0.08 in) Allen key.  
T15 and T17 housing: Loosen setscrew with a 3 mm (0.12 in) Allen key.
2. Rotate housing (max. up to 380°).
3. Retighten setscrew with 1 Nm (0,74 lbf ft).

### 4.3.10 Closing the housing cover

#### NOTICE

#### Devices with EPDM cover seal - transmitter leakiness!

Mineral-based, animal-based or vegetable-based lubricants cause the EPDM cover seal to swell and the transmitter to become leaky.

- ▶ The thread is coated at the factory and therefore does not require any lubrication.

#### NOTICE

#### The housing cover can no longer be closed.

Damaged thread!

- ▶ When closing the housing cover, please ensure that the thread of the cover and housing are free from dirt, e.g. sand. If you feel any resistance when closing the cover, check the thread on both again to ensure that they are free from dirt.

### Closing the covers on the hygienic stainless steel housing (T17)

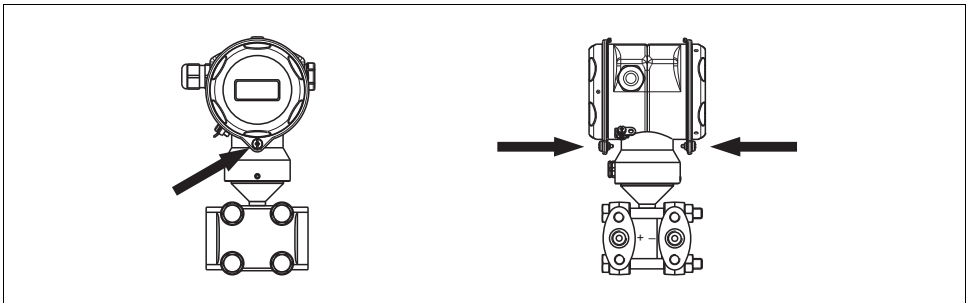

Fig. 4: Closing the covers

P01-PMD75xxx-17-xx-xx-xx-000

The covers for the terminal and electronics compartment are hooked into the housing and closed with a screw. These screws should be tightened handtight (2 Nm (1.48 lbf ft)) to the stop to ensure that the covers sit tightly.

## 4.4 Post-installation check

After installing the device, carry out the following checks:

- Are all screws firmly tightened?
- Are the housing covers screwed down tight?
- Are all locking screws and vent valves firmly tightened?

## 5 Wiring

### 5.1 Connecting the device

#### **⚠ WARNING**



##### **Risk of electric shock!**

If the operating voltage is  $> 35$  VDC: Dangerous contact voltage at terminals.

- ▶ In a wet environment, do not open the cover if voltage is present.

#### **⚠ WARNING**

##### **Limitation of electrical safety due to incorrect connection!**

- Risk of electric shock and/or explosion in hazardous areas! In a wet environment, do not open the cover if voltage is present.
- When using the measuring device in hazardous areas, installation must comply with the corresponding national standards and regulations and the Safety Instructions or Installation or Control Drawings.
- Devices with integrated overvoltage protection must be grounded.
- Protective circuits against reverse polarity, HF influences and overvoltage peaks are installed.
- The supply voltage must match the power supply on the nameplate. (→  11, Section 3.2.1 "Nameplates".)
- Switch off the supply voltage before connecting the device.
- Remove the housing cover of the terminal compartment.
- Guide the cable through the gland. → For cable specifications, →  24, Section 5.2.4.
- Connect the device in accordance with the following diagram.
- Screw down the housing cover.
- Switch on the supply voltage.

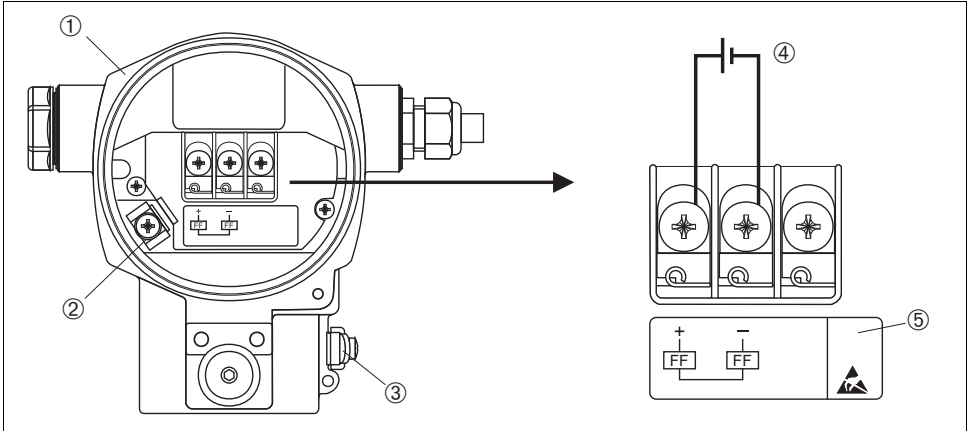

P01-xMx7/xxxx-04-xx-xx-xx-009

Fig. 5: Electrical connection of FOUNDATION Fieldbus  
 → Please refer also to Section 5.2.1 "Supply voltage", → 24.

- 1 Housing
- 2 Internal ground terminal
- 3 External ground terminal
- 4 Supply voltage, for version in non-hazardous area = 9 to 32 V DC
- 5 Devices with integrated overvoltage protection are labeled OVP (overvoltage protection) here.

### 5.1.1 Connecting devices with 7/8" plug

PIN assignment for 7/8" connector	PIN	Meaning
	PIN	Meaning
	1	Signal -
	2	Signal +
	3	Shield
	4	Not assigned

A0011176

## 5.2 Connecting the measuring unit

For further information on the network structure and grounding and for further bus system components such as bus cables, see the relevant documentation, e.g. Operating Instructions BA00013S "FOUNDATION Fieldbus Overview" and the FOUNDATION Fieldbus Guideline.

### 5.2.1 Supply voltage

- Version for non-hazardous area: 9 to 32 V DC

#### **⚠ WARNING**

#### **Supply voltage might be connected!**

Risk of electric shock and/or explosion!

- ▶ When using the measuring device in hazardous areas, installation must comply with the corresponding national standards and regulations and the Safety Instructions or Installation or Control Drawings.
- ▶ All explosion protection data are given in separate documentation which is available upon request. The Ex documentation is supplied as standard with all devices approved for use in explosion hazardous areas.

### 5.2.2 Current consumption

15.5 mA  $\pm$  1 mA, switch-on current corresponds to IEC 61158-2, Clause 21.

### 5.2.3 Terminals

- Supply voltage and internal ground terminal: 0.5 to 2.5 mm<sup>2</sup> (20 to 14 AWG)
- External ground terminal: 0.5 to 4 mm<sup>2</sup> (20 to 12 AWG)

### 5.2.4 Cable specification

- Use a twisted, shielded two-wire cable, preferably cable type A.
- Outer cable diameter: 5 to 9 mm (0.2 to 0.35 in)

For further information on the cable specifications, see Operating Instructions BA00013S "FOUNDATION Fieldbus Overview", FOUNDATION Fieldbus Guideline and IEC 61158-2 (MBP).

### 5.2.5 Grounding and shielding

Deltabar S must be grounded, for example by means of the external ground terminal.

Different grounding and shielding installation methods are available for FOUNDATION Fieldbus networks such as:

- Isolated installation (see also IEC 61158-2)
- Installation with multiple grounding
- Capacitive installation

## 5.3 Overvoltage protection (optional)

See operating instructions.

## 5.4 Post-connection check

Perform the following checks after completing electrical installation of the device:

- Does the supply voltage match the specifications on the nameplate?
- Is the device connected as per Section 5.1?



- Are all screws firmly tightened?
- Are the housing covers screwed down tight?

As soon as voltage is applied to the device, the green LED on the electronic insert lights up for a few seconds or the connected onsite display lights up.

## 6 Operation

Feature 20 "Output; operation" in the order code provides you with information on the operating options available to you.

Versions in the order code		Operation
P	FOUNDATION Fieldbus; external operation, LCD	Via onsite display and 1 key on the exterior of the device
Q	FOUNDATION Fieldbus; internal operation, LCD	Via onsite display and 1 key on the inside of the device
R	FOUNDATION Fieldbus; internal operation	Without onsite display, 1 key on the inside of the device

### 6.1 Onsite display (optional)

A 4-line liquid crystal display (LCD) is used for display and operation. The onsite display shows measured values, fault messages and notice messages. The display of the device can be turned in 90° steps. Depending on the orientation of the device, this makes it easy to operate the device and read the measured value.

Functions:





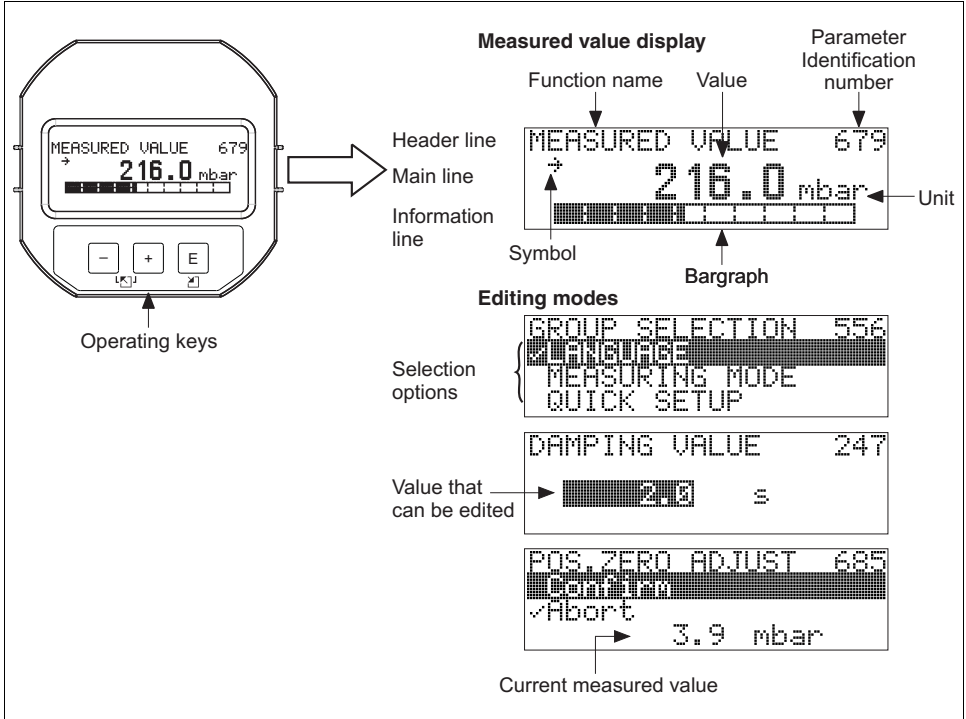



- 8-digit measured value display including sign and decimal point, unit display
- Bar graph as graphic display of the current pressure measured value in relation to the set pressure range in the Pressure Transducer Block. The pressure range is set by means of the SCALE\_IN parameter.
- Easy and complete menu guidance by dividing the parameters into several levels and groups
- Menu guidance
 

The onsite display is available in English. Needless to say, the device can also be operated in 6 languages (de, en, fr, es, jp, ch) via the DTM or EDD. The FieldCare program is an E+H DTM operating tool and can be acquired from [endress.com](http://endress.com).
- Each parameter has a 3-digit ID to aid navigation
- Option of configuring the display according to individual requirements and preferences, such as alternating display, contrast setting, display of other measured values such as sensor temperature
- Comprehensive diagnostic functions (fault and warning message, maximum indicator, etc.)
- Rapid and safe commissioning using Quick Setup menus



P01-xxxxxxx-07-xx-xx-en-011

The following table illustrates the symbols that can appear on the onsite display. Four symbols can occur at one time.

Symbol	Meaning
	<b>Alarm symbol</b> - Symbol flashing: warning, device continues measuring. - Symbol permanently lit: error, device does not continue measuring.  <i>Note:</i> The alarm symbol may overlie the tendency symbol.
	<b>Lock symbol</b> The operation of the device is locked. Unlock device, → <a href="#">35</a> , Section 6.7 "Locking/unlocking operation".
	<b>Communication symbol</b> Data transfer via communication
	<b>Square root symbol</b> Active measuring mode "Flow measurement"
	<b>Simulation symbol</b> Simulation mode is activated. DIP switch 2 for simulation is set to "On". → See also Section 6.2.1 "Position of the operating elements" and → <a href="#">36</a> , Section 6.8 "Simulation".
	<b>Tendency symbol (increasing)</b> The primary value of the Pressure Transducer Block is increasing.
	<b>Tendency symbol (decreasing)</b> The primary value of the Pressure Transducer Block is decreasing.
	<b>Tendency symbol (constant)</b> The primary value of the Pressure Transducer Block has remained constant over the past few minutes.

## 6.2 Operating elements

### 6.2.1 Position of the operating elements

On the aluminum housing (T14/T15), the operating key is located either under the protective flap on the exterior of the device or inside on the electronic insert. In the case of the hygienic stainless steel housing (T17), the operating key is always inside on the electronic insert. In addition, there are three operating keys on the optional onsite display.

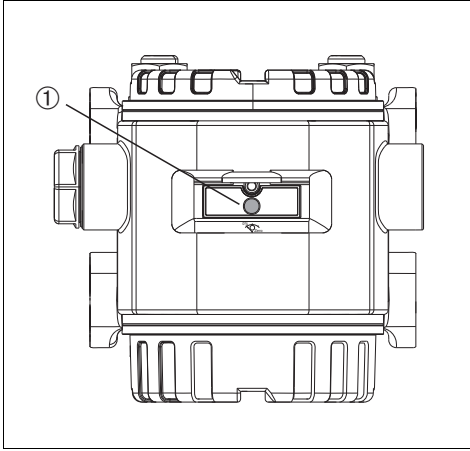

P01-xMD7xxxx-19-xx-xx-xx-074

Fig. 6: Operating key external, under the protective flap

- 1 Operating key for position adjustment (zero point correction) and total reset

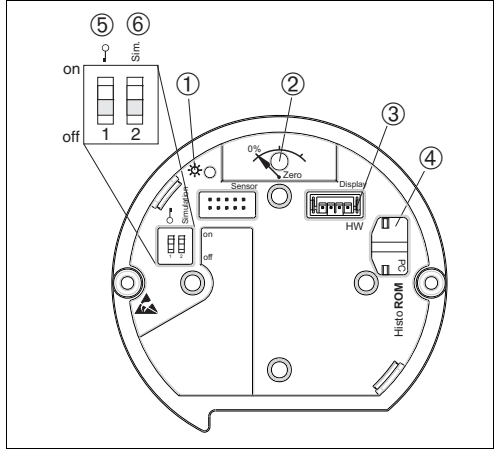

P01-xxxxxxxx-19-xx-xx-xx-106

Fig. 7: Operating keys, internal

- 1 Green LED to indicate value is accepted
- 2 Operating key for position adjustment (zero point correction) and total reset
- 3 Slot for optional display
- 4 Slot for optional HistoROM®/M-DAT
- 5 DIP switch for locking/unlocking parameters relevant to the measured value
- 6 DIP switch for simulation mode

### 6.2.2 Function of operating elements

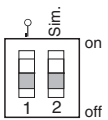
Key(s)	Meaning
 <p>P02-xxxxxxxx-19-xx-xx-xx-107</p>	<ul style="list-style-type: none"> <li>- Position adjustment (zero point correction): press key for at least 3 seconds. The LED on the electronic insert lights up briefly if the pressure applied has been accepted for position adjustment. → See also the following section "Performing position adjustment on site".</li> <li>- Total reset: press key for at least 12 seconds. The LED on the electronic insert lights up briefly if a reset is being carried out.</li> </ul>
 <p>P01-xxxxxxxx-19-xx-xx-xx-134</p>	<ul style="list-style-type: none"> <li>- DIP switch 1: for locking/unlocking parameters relevant to the measured value. Factory setting: off (unlocked) → 35, Section 6.7 "Locking/unlocking operation".</li> <li>- DIP switch 2: for simulation mode. Factory setting: off (simulation mode off) → 36, Section 6.8 "Simulation"</li> </ul>

### Performing position adjustment on site











- Operation must be unlocked. → 35, Section 6.7 "Locking/unlocking operation".

- The device is configured for the Pressure measuring mode as standard.
  - Operation via FF configuration program: In the Pressure Transducer Block, change the measuring mode by means of the PRIMARY\_VALUE\_TYPE and LINEARIZATION parameters.
  - Operation via digital communication: change the measuring mode by means of the MEASURING MODE parameter.
  - You can change the measuring mode by means of the MEASURING MODE parameter.
    -  37, Section 7.4 "Selecting the language and measuring mode".
- The pressure applied must be within the nominal pressure limits of the sensor. See information on the nameplate.

Perform position adjustment:

1. Pressure is present at device.
2. Press key for at least 3 seconds.
3. If the LED on the electronic insert lights up briefly, the pressure applied has been accepted for position adjustment.  
If the LED does not light up, the pressure applied was not accepted. Observe the input limits. For error messages see operating instructions..

### 6.2.3 Function of the operating elements – onsite display connected

Key(s)	Meaning
	<ul style="list-style-type: none"> <li>– Navigate upwards in the picklist</li> <li>– Edit numerical values or characters within a function</li> </ul>
	<ul style="list-style-type: none"> <li>– Navigate downwards in the picklist</li> <li>– Edit numerical values or characters within a function</li> </ul>
	<ul style="list-style-type: none"> <li>– Confirm entry</li> <li>– Go to next item</li> </ul>
 and 	Contrast setting of onsite display: increase
 and 	Contrast setting of onsite display: reduce
 and 	<p>ESC functions:</p> <ul style="list-style-type: none"> <li>– Exit the editing mode without saving the altered value</li> <li>– You are in the menu within a function group: the first time you press the keys simultaneously, you go back one parameter in the function group. Every subsequent time you press the keys simultaneously, you go up one level in the menu.</li> <li>– You are in the menu on a selection level: every time you press the keys simultaneously, you go up one level in the menu.</li> </ul> <p>Note: For the terms function group, level, selection level, →  31, Section 6.4.1</p>

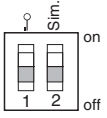
Key(s)	Meaning
 <p>P01-xxxxxxxx-19-xx-xx-xx-134</p>	<ul style="list-style-type: none"> <li>- DIP switch 1: for locking/unlocking parameters relevant to the measured value. Factory setting: off (unlocked)</li> <li>- DIP switch 2: for the simulation mode Factory setting: off (simulation mode off)</li> </ul>

## 6.3 FOUNDATION Fieldbus interface

See operating instructions.

### 6.3.1 Device identification and addressing

FOUNDATION Fieldbus identifies the device using its ID code and automatically assigns it a suitable field address. The identity code cannot be changed.

The device appears in the network display once you have started the FF configuration program and integrated the device into the network. The blocks available are displayed under the device name.

If the device description has not yet been loaded, the blocks report "Unknown" or "(UNK)".

Deltabar S reports as follows:

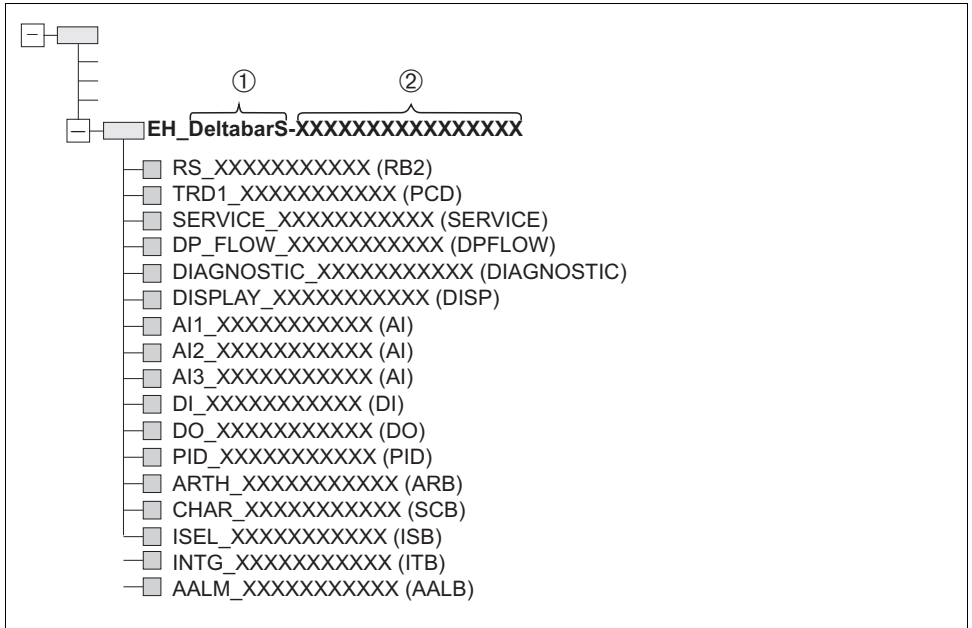

P01-xMx/xxxx-05-xx-xx-xx-005

Fig. 8: Typical Deltabar S display in a configuration program after the connection has been established

- 1 Device name
- 2 Serial number

## 6.4 Local operation – onsite display connected

If the onsite display is connected, the three operating keys are used to navigate through the operating menu, → 29, Section 6.2.3 "Function of the operating elements – onsite display connected".

### 6.4.1 Menu structure

The menu is split into four levels. The three upper levels are used to navigate while you use the lowest level to enter numerical values, and select and save options.

The structure of the MEASURING MENU depends on the measuring mode selected, e.g. if "Pressure" is selected as the measuring mode, only the functions needed for this measuring mode are displayed.

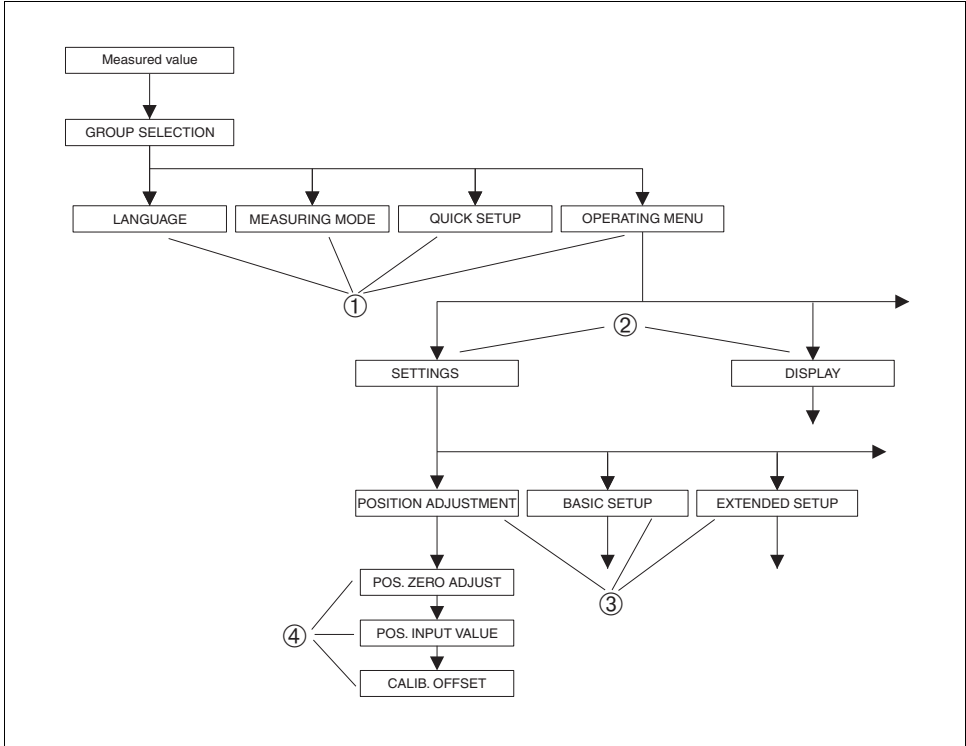

P01-xxxxxxxx-19-xx-xx-xx-145

Fig. 9: Menu structure

- 1 1st selection level
- 2 2nd selection level
- 3 Function groups
- 4 Parameters

The MEASURING MODE parameter is only displayed via the onsite display on the 1st selection level. In FieldCare, the LANGUAGE parameter is displayed in the DISPLAY group and the parameters for configuring the measuring mode are displayed in the Measuring Mode menu.



### 6.4.2 Selecting an option

Example: Selecting the "Pressure" measuring mode.

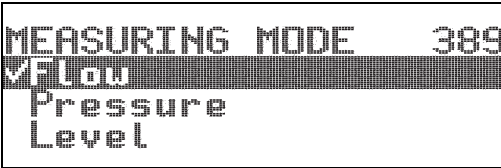
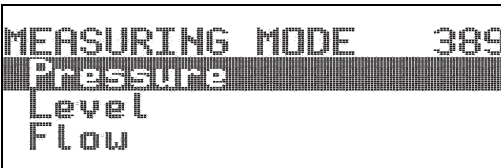
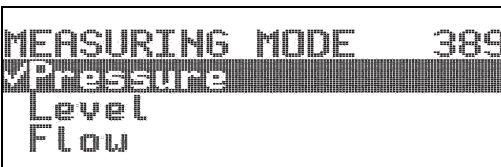
Onsite display	Operation
 <p>MEASURING MODE 389 3 Flow Pressure Level</p> <p style="text-align: right; font-size: small;">MEASURINGMODE_Flow</p>	<p>"Flow" has been selected as the measuring mode. The option currently active is indicated by a 3 in front of the menu text.</p>
 <p>MEASURING MODE 389 3 Pressure Level Flow</p> <p style="text-align: right; font-size: small;">MEASURINGMODE_Press</p>	<p>Use "+" or "-" to select "Pressure" as the operating mode.</p>
 <p>MEASURING MODE 389 3 Pressure Level Flow</p> <p style="text-align: right; font-size: small;">MEASURINGMODE_Press-1</p>	<ol style="list-style-type: none"> <li>1. Press "E" to confirm your choice. The option currently active is indicated by a 3 in front of the menu text. (The "Pressure" measuring mode is selected.)</li> <li>2. Go to the next menu item with "E" .</li> </ol>

### 6.4.3 Editing a value

Example: changing the DAMPING VALUE function from 2.0 s to 30.0 s. → 29, Section 6.2.3 "Function of the operating elements – onsite display connected".

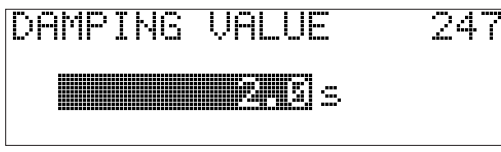
Onsite display	Operation
 <p>DAMPING VALUE 247 2.0 s</p> <p style="text-align: right; font-size: small;">P01-xxxxxxxx-19-xx-xx-ent-023</p>	<p>The onsite display indicates the parameter to be modified. The value highlighted in black can be modified. The unit "s" is prespecified and cannot be changed.</p>

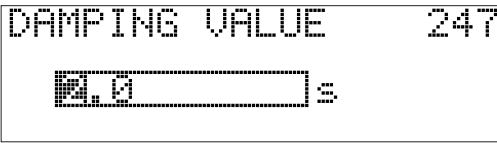
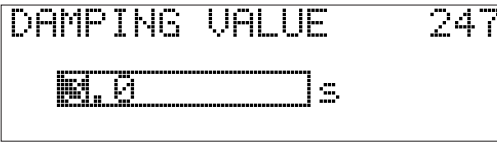
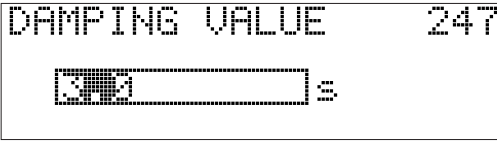
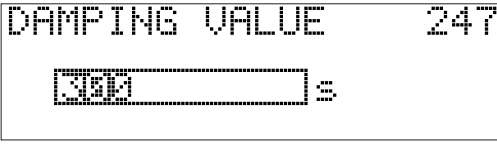
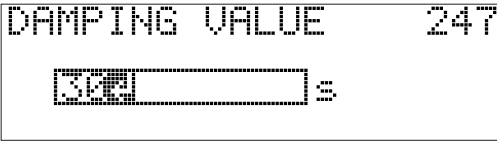
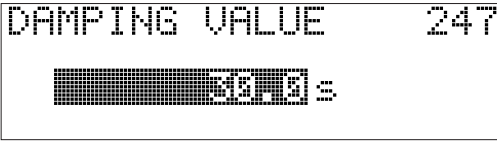
Onsite display	Operation
 <p style="text-align: right; font-size: small;">P01-xxxxxxx-19-xx-xx-en-027</p>	<ol style="list-style-type: none"> <li>1. Press "+" or "-" to enter the editing mode.</li> <li>2. The first digit is highlighted in black.</li> </ol>
 <p style="text-align: right; font-size: small;">P01-xxxxxxx-19-xx-xx-en-028</p>	<ol style="list-style-type: none"> <li>1. Use the "+" key to change the digit "2" to "3".</li> <li>2. Press the "E" key to confirm "3". The cursor goes to the next position (highlighted in black).</li> </ol>
 <p style="text-align: right; font-size: small;">P01-xxxxxxx-19-xx-xx-en-029</p>	<p>The decimal point is highlighted in black. This means you can now edit this digit.</p>
 <p style="text-align: right; font-size: small;">P01-xxxxxxx-19-xx-xx-en-030</p>	<ol style="list-style-type: none"> <li>1. Press "+" or "-" until "0" is displayed.</li> <li>2. Press the "E" key to confirm "0". The cursor goes to the next position. .1 is displayed and highlighted in black. → See next graphic.</li> </ol>
 <p style="text-align: right; font-size: small;">P01-xxxxxxx-19-xx-xx-en-031</p>	<p>Press "E" to save the new value and exit the editing mode. → See next graphic.</p>
 <p style="text-align: right; font-size: small;">P01-xxxxxxx-19-xx-xx-en-032</p>	<p>The new value for the damping is 30.0 s.</p> <ul style="list-style-type: none"> <li>- Go to the next parameter with "E".</li> <li>- Press "+" or "-" to go back to the editing mode.</li> </ul>

### 6.4.4 Accepting pressure present at device as value

Example: performing position adjustment.

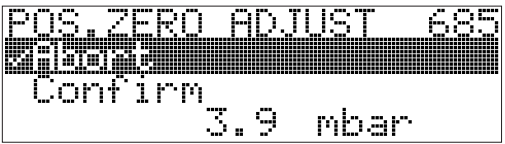
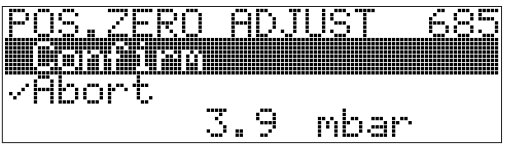
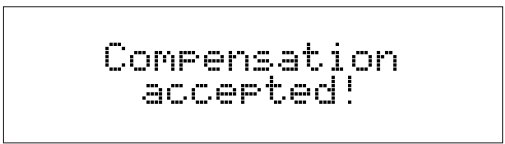
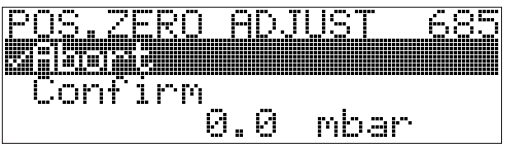
Onsite display	Operation
 <p style="text-align: center; font-size: small;">P01-xxxxxxxx-19-xx-xx-en-158</p>	<p>The bottom line on the onsite display displays the pressure present, 3.9 mbar in this example.</p>
 <p style="text-align: center; font-size: small;">P01-xxxxxxxx-19-xx-xx-en-159</p>	<p>Use "+" or "-" to switch to the "Confirm" option. The active option is highlighted in black.</p>
 <p style="text-align: center; font-size: small;">P01-xxxxxxxx-19-xx-xx-en-037</p>	<p>Using the "E" key, assign the value (3.9 mbar) to the POS. ZERO ADJUST parameter. The device confirms the adjustment and goes back to the parameter, here POS. ZERO ADJUST (see next graphic).</p>
 <p style="text-align: center; font-size: small;">P01-xxxxxxxx-19-xx-xx-en-160</p>	<p>Go to the next parameter with "E".</p>

### 6.5 HistoROM<sup>®</sup>/M-DAT (optional)

See operating instructions.

### 6.6 FieldCare

See operating instructions.

### 6.7 Locking/unlocking operation

See operating instructions.

## 6.8 Simulation

See operating instructions.

## 6.9 Factory setting (reset)

See operating instructions.

# 7 Commissioning

The device is configured for the Pressure measuring mode as standard. The measuring range and the unit in which the measured value is transmitted correspond to the specifications on the nameplate.

### **⚠ WARNING**

#### **Exceeding the maximum allowable working pressure!**

Risk of injury due to bursting of parts! Warning messages are generated if pressure is too high.

- ▶ If a pressure greater than the maximum permitted pressure is present at the device, the messages "E115 Sensor overpressure" and "E727 Sensor pressure error - overrange" are output in succession! Use the device only within the sensor range limits

### **NOTICE**

#### **Shortfall of the allowable working pressure!**

Output of messages if pressure is too low.

- ▶ If a pressure smaller than the minimum permitted pressure is present at the device, the messages "E120 Sensor low pressure" and "E727 Sensor pressure error - overrange" are output in succession! Use the device only within the sensor range limits

## 7.1 Configuring messages

- The messages E727, E115 and E120 are "Error"-type messages and can be configured as a "Warning" or an "Alarm". The factory setting for these messages is "Warning". This setting prevents the BAD status from being transmitted in applications (e.g. cascade measurement) where the user is aware of the risk of the sensor range being overshoot.
- We recommend setting messages E727, E115 and E120 to "Alarm" in the following instances:
  - It is not necessary to violate the sensor range for the measuring application.
  - A position adjustment must be carried out that has to correct a large measured error as a result of the orientation of the device.

## 7.2 Function check

Carry out a post-installation and a post-connection check as per the checklist before commissioning the device.

- "Post-installation check" checklist → see Section 4.4

- "Post-connection check" checklist → see Section 5.4

### 7.3 Commissioning via an FF configuration program

See operating instructions.

### 7.4 Selecting the language and measuring mode

#### 7.4.1 Local operation

The MEASURING MODE parameter is on the 1st selection level. →  31, Section 6.4.1 "Menu structure".

The following measuring modes are available:

- Pressure
- Level
- Flow

#### 7.4.2 Selecting the language and measuring mode by means of the FieldCare operating program

See operating instructions.

### 7.5 Position adjustment

Due to the orientation of the device, there may be a shift in the measured value, i.e. when the container is empty or partly filled, the measured value parameter does not display zero. There are three options to choose from when performing position adjustment.

- Onsite display menu path: GROUP SELECTION → OPERATING MENU → SETTINGS → POSITION ADJUSTMENT
- FieldCare menu path: OPERATING MENU → SETTINGS → POSITION ADJUSTMENT

#### 7.5.1 Performing position adjustment via the onsite display or FieldCare

The parameters listed in the following table can be found in the POSITION ADJUSTMENT group (menu path: OPERATING MENU → SETTINGS → POSITION ADJUSTMENT).

Parameter name	Description
POS. ZERO ADJUST Entry	<p>Position adjustment – the pressure difference between zero (set point) and the measured pressure need not be known.</p> <p><b>Example:</b></p> <ul style="list-style-type: none"> <li>– MEASURED VALUE = 2.2 mbar (0.032 psi)</li> <li>– Correct the MEASURED VALUE via the POS. ZERO ADJUST parameter with the "Confirm" option. This means that you are assigning the value 0.0 to the pressure present.</li> <li>– MEASURED VALUE (after pos. zero adjust) = 0.0 mbar</li> </ul> <p>The CALIB. OFFSET parameter displays the resulting pressure difference (offset) by which the MEASURED VALUE was corrected.</p> <p><b>Factory setting:</b> 0.0</p>
POS. INPUT VALUE Input	<p>Position adjustment – the pressure difference between zero (set point) and the measured pressure need not be known. To correct the pressure difference, you need a reference measurement value (e. g. from a reference device).</p> <p><b>Example:</b></p> <ul style="list-style-type: none"> <li>– MEASURED VALUE = 0.5 mbar (0.0073 psi)</li> <li>– For the POS. INPUT VALUE parameter, specify the desired set point for the MEASURED VALUE, e.g. 2.0 mbar (0.029 psi). (The following applies: <math>MEASURED\ VALUE_{new} = POS.\ INPUT\ VALUE</math>)</li> <li>– MEASURED VALUE (after entry for POS. INPUT VALUE) = 2.0 mbar (0.029 psi)</li> <li>– The CALIB. OFFSET parameter displays the resulting pressure difference (offset) by which the MEASURED VALUE was corrected. The following applies: <math>CALIB.\ OFFSET = MEASURED\ VALUE_{old} - POS.\ INPUT\ VALUE</math>, here: <math>CALIB.\ OFFSET = 0.5\ mbar\ (0.0073\ psi) - 2.0\ mbar\ (0.029\ psi) = -1.5\ mbar\ (0.022\ psi)</math></li> </ul> <p><b>Factory setting:</b> 0.0</p>
CALIB. OFFSET Entry	<p>Position adjustment – the pressure difference between zero (set point) and the measured pressure is known. (A reference pressure is not present at the device.)</p> <p><b>Example:</b></p> <ul style="list-style-type: none"> <li>– MEASURED VALUE = 2.2 mbar (0.032 psi)</li> <li>– Via the CALIB. OFFSET parameter, enter the value by which the MEASURED VALUE should be corrected. To correct the MEASURED VALUE to 0.0 mbar, you must enter the value 2.2 here. (The following applies: <math>MEASURED\ VALUE_{new} = MEASURED\ VALUE_{old} - CALIB.\ OFFSET</math>)</li> <li>– MEASURED VALUE (after entry for calib. offset) = 0.0 mbar</li> </ul> <p><b>Factory setting:</b> 0.0</p>

## 7.6 Flow measurement

### 7.6.1 Preparatory steps

- The Deltabar S PMD75 is usually used for flow measurement.
- Before calibrating the Deltabar S, the pressure piping must be cleaned and the device filled with fluid. → See the following table.

	Valves	Meaning	Preferred installation	
1	Close 3.			
2	Fill measuring system with fluid. Open A, B, 2, 4.	Fluid flows in.		
3	Clean pressure piping if necessary <sup>1)</sup> : - by blowing out with compressed air in the case of gases - by rinsing out in the case of liquids. Close 2 and 4.	Block off device.		
	Open 1 and 5. <sup>1</sup>	Blow out/rinse out pressure piping.		
	Close 1 and 5. <sup>1</sup>	Close valves after cleaning.		
4	Vent device. Open 2 and 4.	Introduce fluid.		
	Close 4.	Close negative side.		
	Open 3.	Balance positive and negative side.		
	Open 6 and 7 briefly, then close them again.	Fill device completely with fluid and remove air.		
5	Carry out pos. zero adjustment if the following conditions are met. If the conditions are not met, then do not carry out the pos. zero adjustment until after step 6. → 41, Section 7.6.3 and → 37, Section 7.5. Conditions: - The process cannot be blocked off. - The tapping points (A and B) are at the same geodetic height.			
6	Set measuring point to operation. Close 3.	Shut off positive side from negative side.		
	Open 4.	Connect negative side.		
	Now - 1 <sup>1</sup> , 3, 5 <sup>1</sup> , 6 and 7 are closed. - 2 and 4 are open. - A and B are open (if present).			
7	Carry out pos. zero adjustment if the flow can be blocked off. In this case, step 5 is not applicable. → 41, Section 7.6.3 and → 37, Section 7.5.			
8	Carry out calibration. → 40, Section 7.6.2			

Fig. 10: Above: preferred installation for gases

Below: preferred installation for liquids

- I Deltabar S PMD75
- II Three-way valve manifold
- III Separator
- 1, 5 Drain valves
- 2, 4 Inlet valves
- 3 Equalizing valve
- 6, 7 Vent valves on Deltabar S
- A, B Shutoff valves

1) For arrangement with 5 valves

## 7.6.2 Information on flow measurement

In the "Flow" measuring mode, the device determines a volume or mass flow value from the differential pressure measured. The differential pressure is generated by means of primary devices such as Pitot tubes or orifice plates and depends on the volume flow or mass flow. Four flow measuring modes are available: volume flow, norm volume flow (European norm conditions), standard volume flow (American standard conditions) and mass flow.

In addition, the Deltabar S software is equipped with two totalizers as standard. The totalizers add up the volume or the mass flow. The counting function and the unit can be set separately for both totalizers. The first totalizer (totalizer 1) can be reset to zero at any time while the second (totalizer 2) totalizes the flow from commissioning onwards and cannot be reset.

- By means of the FieldCare operating program, a Quick Setup menu is available for each of the measuring modes pressure, level and flow which guides you through the most important basic functions. With the setting in the MEASURING MODE parameter, you specify which Quick Setup menu should be displayed. →  37, Section 7.4 "Selecting the language and measuring mode". No Quick Setup menus are available for the FF configuration programs.
- For a detailed description of the parameters, see Operating Instructions BA00303P "Cerabar S/Deltabar S/Deltapilot S, Description of Device Functions"
  - FF, Pressure Transducer Block Table
  - FF, DP Flow Block Table
  - FieldCare, POSITION ADJUSTMENT Table
  - FieldCare, BASIC SETUP Table
  - FieldCare, EXTENDED SETUP Table
  - FieldCare, TOTALIZER SETUP Table

### WARNING

#### Changing the measuring mode affects the span (URV)!

This situation can result in product overflow.

- ▶ If the measuring mode is changed, the span setting (URV) must be verified in the "Calibration" → "Basic Setup" operating menu and, if necessary, reconfigured!



### 7.6.3 Quick Setup menu for the Flow measuring mode (FieldCare)

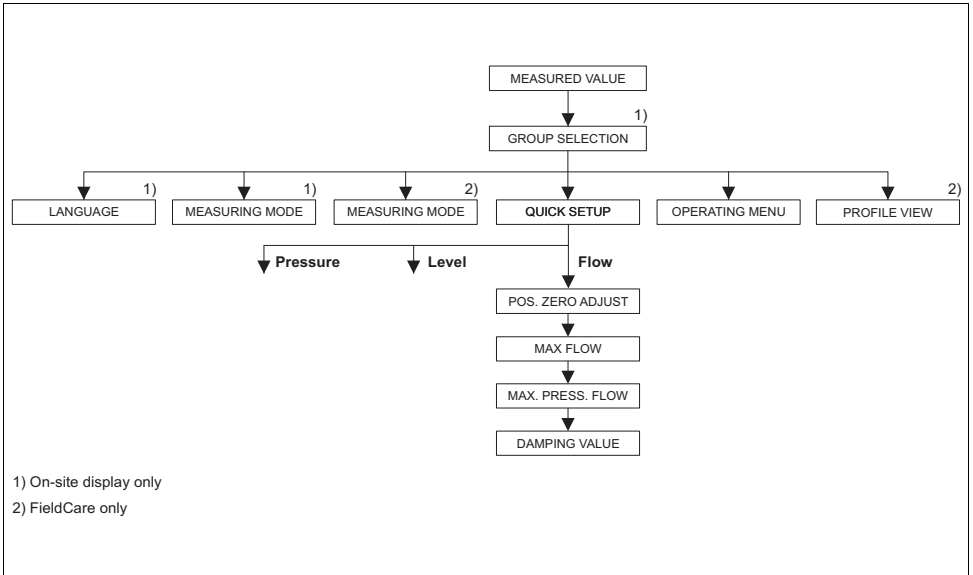



Fig. 11: Quick Setup menu for the "Flow" measuring mode

P01-xxxxxxx-19-xx-xx-en-166

Local operation	FieldCare
<b>Measured value display</b> Onsite display: Switch from the measured value display to GROUP SELECTION with F .	<b>Measured value display</b> Select QUICK SETUP menu.
<b>GROUP SELECTION</b> Select MEASURING MODE.	<b>Measuring Mode</b> Select the Primary Value Type parameter.
<b>MEASURING MODE</b> Select "Flow" option.	<b>Primary Value Type</b> Select "Flow" option.
<b>POS. ZERO ADJUST</b> Due to orientation of the device, there may be a shift in the measured value. You correct the MEASURED VALUE via the POS. ZERO ADJUST parameter with the "Confirm" option, i.e. you assign the value 0.0 to the pressure present.	<b>POS. ZERO ADJUST</b> Due to orientation of the device, there may be a shift in the measured value. You correct the MEASURED VALUE via the POS. ZERO ADJUST parameter with the "Confirm" option, i.e. you assign the value 0.0 to the pressure present.
<b>MAX. FLOW</b> Enter maximum flow of primary device. (→ See also layout sheet of primary device).	<b>MAX. FLOW</b> Enter maximum flow of primary device. (→ See also layout sheet of primary device).

Local operation	FieldCare
<p><b>MAX. PRESS. FLOW</b> Enter maximum pressure of primary device. (→ See also layout sheet of primary device).</p>	<p><b>MAX. PRESS. FLOW</b> Enter maximum pressure of primary device. (→ See also layout sheet of primary device).</p>
<p><b>DAMPING VALUE</b> Enter damping time (time constant <math>\tau</math>). The damping affects the speed at which all subsequent elements, such as the onsite display, measured value and the OUT Value of the Analog Input Block react to a change in the pressure.</p>	<p><b>DAMPING VALUE</b> Enter damping time (time constant <math>\tau</math>). The damping affects the speed at which all subsequent elements, such as the onsite display, measured value and the OUT Value of the Analog Input Block react to a change in the pressure.</p>

For onsite operation, see also →  29, Section 6.2.3 "Function of the operating elements – onsite display connected" and →  31, Section 6.4 "Local operation – onsite display connected".

## 7.7 Level measurement

### 7.7.1 Preparatory steps

#### Open container

- The Deltabar S PMD75, and FMD77 are usually suitable for level measurement in an open container.
- FMD77: the device is ready for calibration immediately after opening a shutoff valve (may or may not be present).
- PMD75: before calibrating the device, the pressure piping must be cleaned and filled with fluid. → See the following table.

	Valves	Meaning	Installation
1	Fill container to a level above the lower tap.		<p style="text-align: right; font-size: small;">P01-xMD7/xxxx-11-xx-xx-xx-003</p>
2	Fill measuring system with fluid.		
	Open A.	Open shutoff valve.	
3	Vent device.		
	Open 6 briefly, then close it again.	Fill device completely with fluid and remove air.	
4	Set measuring point to operation.		<p>Now</p> <ul style="list-style-type: none"> <li>- B and 6 are closed.</li> <li>- Axis open.</li> </ul>
5	Carry out calibration. → 46, Section 7.7.2.		

Fig. 12: Open container

- I Deltabar S PMD75
- II Separator
- 6 Vent valves on Deltabar S
- A Shutoff valve
- B Drain valve

### Closed container

- All Deltabar S versions are suitable for level measurement in closed containers.
- FMD77: the device is ready for calibration immediately after opening the shutoff valves (may or may not be present).
- FMD78: the device is ready for calibration immediately.
- PMD75: before calibrating the device, the pressure piping must be cleaned and filled with fluid. → See the following table.

	Valves	Meaning	Installation
1	Fill container to a level above the lower tap.		
2	Fill measuring system with fluid.		
	Close 3.	Shut off positive side from negative side.	
	Open A and B.	Open shutoff valves.	
3	Vent positive side (empty negative side if necessary).		
	Open 2 and 4.	Introduce fluid on positive side.	
	Open 6 and 7 briefly, then close them again.	Fill positive side completely with fluid and remove air.	
4	Set measuring point to operation.		
	Now		
	- 3, 6 and 7 are closed.		
	- 2, 4, A and B are open.		
5	Carry out calibration. → 46, Section 7.7.2.		

Fig. 13: Closed container

P01-xMD7xxxx-11-xx-xx-xx-004

- I Deltabar S PMD75
- II Three-way valve manifold
- III Separator
- 1, 2 Drain valves
- 2, 4 Inlet valves
- 3 Equalizing valve
- 6, 7 Vent valve on Deltabar S
- A, B Shutoff valve

### Closed container with superimposed steam

- All Deltabar S versions are suitable for level measurement in containers with superimposed steam.
- FMD77: the device is ready for calibration immediately after opening the shutoff valves (may or may not be present).
- FMD78: the device is ready for calibration immediately.
- PMD75: before calibrating the device, the pressure piping must be cleaned and filled with fluid. → See the following table.

	Valves	Meaning	Installation
1	Fill container to a level above the lower tap.		<p style="text-align: right; font-size: small;">P01-xMD7xxxx-11-xx-xx-xx-005</p>
2	Fill measuring system with fluid.		
	Open A and B.	Open shutoff valves.	
	Fill the negative pressure piping to the level of the condensate trap.		
3	Vent device.		
	Open 2 and 4.	Introduce fluid.	
	Close 4.	Close negative side.	
	Open 3.	Balance positive and negative side.	
	Open 6 and 7 briefly, then close them again.	Fill device completely with fluid and remove air.	
4	Set measuring point to operation.		
	Close 3.	Shut off positive side from negative side.	
	Open 4.	Connect negative side.	
	Now - 3, 6 and 7 are closed. - 2, 4, A and B are open.		
5	Carry out calibration. → 46, Section 7.7.2.		

Fig. 14: Closed container with superimposed steam

- I Deltabar S PMD75
- II Three-way valve manifold
- III Separator
- 1, 5 Drain valves
- 2, 4 Inlet valves
- 3 Equalizing valve
- 6, 7 Vent valves on Deltabar S
- A, B Shutoff valves

### 7.7.2 Information on level measurement

- A Quick Setup menu is available for each of the measuring modes Pressure and Level which guides you through the most important basic functions. → For the "Level" Quick Setup menu, →  47.
- Furthermore, three level modes are available for the level measurement, namely "Level easy pressure", "Level easy height" and "Level standard". For the "Level standard" level mode, you can choose between the "Linear", "Pressure linearized" and "Height linearized" level types. The table in the "Overview of level measurement" section that follows provides you with an overview of the various measuring tasks.
  - With regard to the "Level easy pressure" and "Level easy height" level modes, the values entered are not tested as extensively as in the "Level standard" level mode. In the "Level easy pressure" and "Level easy height" level modes, the values entered for EMPTY CALIBRATION/FULL CALIBRATION, EMPTY PRESSURE/FULL PRESSURE and EMPTY HEIGHT/FULL HEIGHT have to be at least 1% apart. The value will be rejected with a warning message if the values are too close together. Further limit values are not checked; i.e. the values entered must be appropriate for the sensor and the measuring task so that the measuring device can measure correctly.
  - The "Level easy pressure" and "Level easy height" level modes comprise fewer parameters than the "Level standard" mode and are not used to quickly and easily configure a level application.
  - Customer-specific units of level, volume and mass, or a linearization table, can only be entered in the "Level standard" level mode.
- For a detailed description of the parameters and configuration examples, see Operating Instructions BA00303P "Cerabar S/Deltabar S/ Deltapilot S, Description of Device Functions".

#### **WARNING**

#### **Changing the measuring mode affects the span (URV)!**

This situation can result in product overflow.

- ▶ If the measuring mode is changed, the span setting (URV) must be verified in the "Calibration" → "Basic Setup" operating menu and, if necessary, reconfigured!

### 7.7.3 Overview of level measurement

See operating instructions.

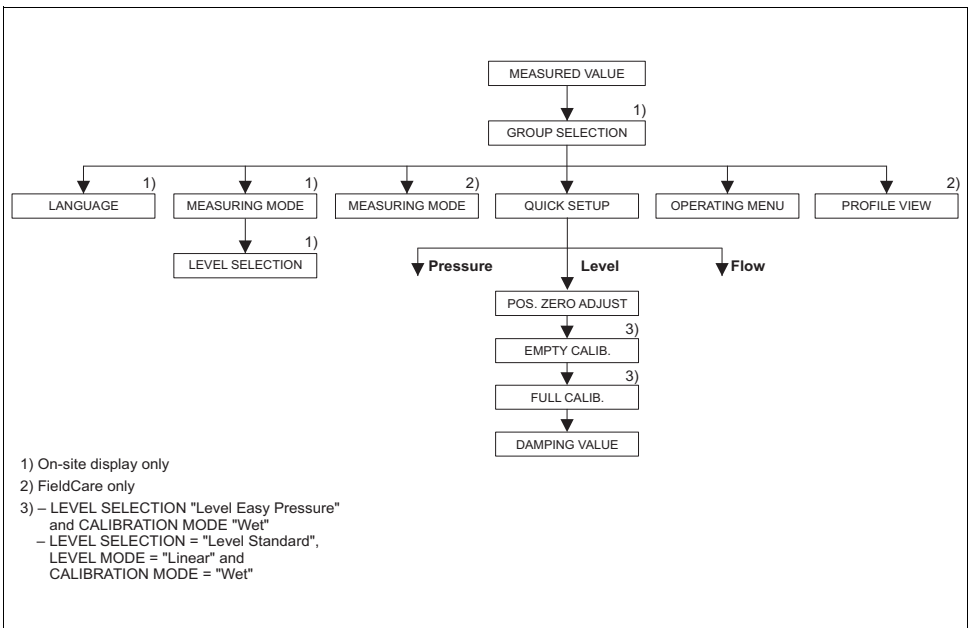

### 7.7.4 Quick Setup menu for Level measuring mode

- Some parameters are only displayed if other parameters are appropriately configured. For example, the EMPTY CALIB. parameter is only displayed in the following cases:
  - LEVEL SELECTION "Level Easy Pressure" and CALIBRATION MODE "Wet"
  - LEVEL SELECTION "Level Standard", LEVEL MODE "Linear" and CALIBRATION MODE "Wet"
 You can find the LEVEL MODE and the CALIBRATION MODE parameter in the BASIC SETTINGS function group.
- The following parameters are set to the following values in the factory:
  - LEVEL SELECTION: Level Easy Pressure
  - CALIBRATION MODE: Wet
  - OUTPUT UNIT or LIN. MEASURAND: %
  - EMPTY CALIB: 0.0
  - FULL CALIB: 100.0
- The quick setup is suitable for simple and quick commissioning. If you wish to make more complex settings, e.g. change the unit form "%" to "m", you will have to calibrate using the BASIC SETTINGS group. → See Operating Instructions BA00303P.





P01-xMD7xxxx-19-xx-xx-en-079

Fig. 15: Quick Setup menu for "Level" measuring mode

Local operation	FieldCare
<p><b>Measured value display</b> Onsite display: Switch from the measured value display to GROUP SELECTION with F .</p>	<p><b>Measured value display</b> Select QUICK SETUP menu.</p>
<p><b>GROUP SELECTION</b> Select MEASURING MODE.</p>	<p><b>Measuring Mode</b> Select the Primary Value Type parameter.</p>
<p><b>MEASURING MODE</b> Select "Level" option.</p>	<p><b>Primary Value Type</b> Select "Level" option.</p>
<p><b>LEVEL SELECTION</b> Select level mode. For an overview see →  46.</p>	<p><b>Level Selection</b> Select level mode. For an overview see →  46.</p>
<p><b>GROUP SELECTION</b> Select QUICK SETUP menu.</p>	
<p><b>POS. ZERO ADJUST</b> Due to orientation of the device, there may be a shift in the measured value. You correct the MEASURED VALUE via the POS. ZERO ADJUST parameter with the "Confirm" option, i.e. you assign the value 0.0 to the pressure present.</p>	<p><b>POS. ZERO ADJUST</b> Due to orientation of the device, there may be a shift in the measured value. You correct the MEASURED VALUE via the POS. ZERO ADJUST parameter with the "Confirm" option, i.e. you assign the value 0.0 to the pressure present.</p>
<p><b>EMPTY CALIB.</b> <sup>1)</sup> Enter level for the lower calibration point. For this parameter, enter a level value which is assigned to the pressure present at the device.</p>	<p><b>EMPTY CALIB.</b> <sup>1)</sup> Enter level for the lower calibration point. For this parameter, enter a level value which is assigned to the pressure present at the device.</p>
<p><b>FULL CALIB.</b> <sup>1)</sup> Enter level for the upper calibration point. For this parameter, enter a level value which is assigned to the pressure present at the device.</p>	<p><b>FULL CALIB.</b> <sup>1)</sup> Enter level for the upper calibration point. For this parameter, enter a level value which is assigned to the pressure present at the device.</p>
<p><b>DAMPING VALUE</b> Enter damping time (time constant <math>\tau</math>). The damping affects the speed at which all subsequent elements, such as the onsite display, measured value and the OUT Value of the Analog Input Block react to a change in the pressure.</p>	<p><b>DAMPING VALUE</b> Enter damping time (time constant <math>\tau</math>). The damping affects the speed at which all subsequent elements, such as the onsite display, measured value and the OUT Value of the Analog Input Block react to a change in the pressure.</p>

- 1) – LEVEL SELECTION "Level Easy Pressure" and CALIBRATION MODE "Wet"  
– LEVEL SELECTION "Level Standard", LEVEL MODE "Linear" and CALIBRATION MODE "Wet"

For onsite operation, see also →  29, Section 6.2.3 "Function of the operating elements – onsite display connected" and →  31, Section 6.4 "Local operation – onsite display connected".

## 7.8 Differential pressure measurement

### 7.8.1 Preparatory steps

- The Deltabar S PMD75 and FMD78 are usually used for differential pressure measurement.
- FMD78: the device is ready for calibration immediately.



- PMD75: before calibrating the device, the pressure piping must be cleaned and filled with fluid. → See the following table.

	Valves	Meaning	Preferred installation
1	Close 3.		
2	Fill measuring system with fluid. Open A, B, 2, 4.	Fluid flows in.	
3	Clean pressure piping if necessary: <sup>1)</sup> - by blowing out with compressed air in the case of gases - by rinsing out in the case of liquids. Close 2 and 4.	Block off device.	
	Open 1 and 5. <sup>1)</sup>	Blow out/rinse out pressure piping.	
	Close 1 and 5. <sup>1)</sup>	Close valves after cleaning.	
4	Vent device. Open 2 and 4. Close 4.	Introduce fluid. Close negative side.	
	Open 3.	Balance positive and negative side.	<p style="text-align: right; font-size: small;">P01-xMD7xxxx-11-xx-xx-xx-002</p>
	Open 6 and 7 briefly, then close them again.	Fill device completely with fluid and remove air.	
5	Set measuring point to operation. Close 3. Open 4.	Shut off positive side from negative side. Connect negative side.	<p>Fig. 16: Above: preferred installation for gases Below: preferred installation for liquids</p>
	Now - 1 <sup>1)</sup> , 3, 5 <sup>1)</sup> , 6 and 7 are closed. - 2 and 4 are open. - A and B are open (if present).		
6	Carry out calibration if necessary. → 50, Section 7.8.2.		<p>I Deltabar S PMD75 II Three-way valve manifold III Separator 1, 5 Drain valves 2, 4 Inlet valves 3 Equalizing valve 6, 7 Vent valves on Deltabar S A, B Shutoff valve</p>

1) For arrangement with 5 valves

### 7.8.2 Information on differential pressure measurement

- By means of the FieldCare operating program, a Quick Setup menu is available for each of the measuring modes pressure, level and flow which guides you through the most important basic functions. With the setting in the MEASURING MODE parameter, you specify which Quick Setup menu should be displayed. → 37, Section 7.4 "Selecting the language and measuring mode". No Quick Setup menus are available for the FF configuration programs.
- For a detailed description of the parameters, see Operating Instructions BA00303P "Cerabar S/Deltabar S/Deltapilot S, Description of Device Functions"
  - FF, Table, Pressure Transducer Block
  - FieldCare, Table, POSITION ADJUSTMENT
  - FieldCare, Table, BASIC SETUP
  - FieldCare, Table, EXTENDED SETUP

**⚠ WARNING**

#### Changing the measuring mode affects the span (URV)!

This situation can result in product overflow.

- ▶ If the measuring mode is changed, the span setting (URV) must be verified in the "Calibration" → "Basic Setup" operating menu and, if necessary, reconfigured!

### 7.8.3 Quick Setup menu for Pressure measuring mode

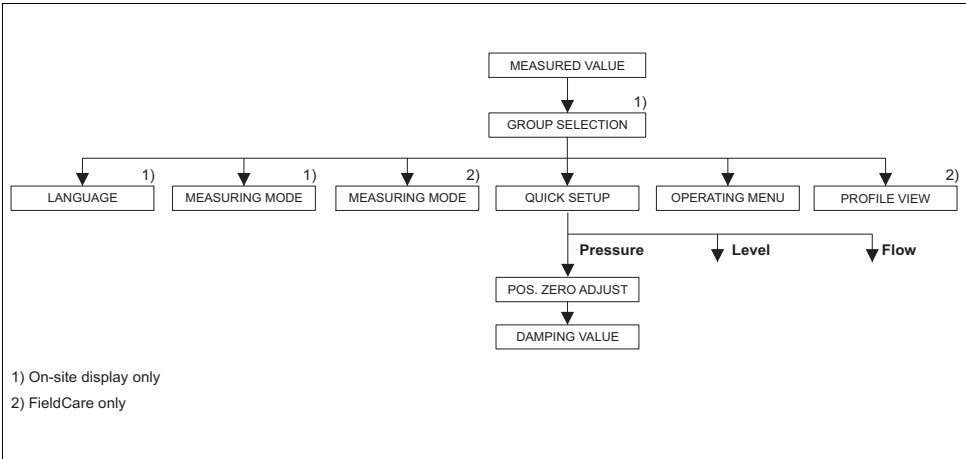

Fig. 17: Quick Setup menu for "Pressure" measuring mode

P01-xMD7:xxxx-19-xx-xx-en-080

Local operation	FieldCare
<b>Measured value display</b> Onsite display: Switch from the measured value display to GROUP SELECTION with F .	<b>Measured value display</b> Select QUICK SETUP menu.

Local operation	FieldCare
<b>GROUP SELECTION</b> Select MEASURING MODE.	<b>Measuring Mode</b> Select the Primary Value Type parameter.
<b>MEASURING MODE</b> Select "Pressure" option.	<b>Primary Value Type</b> Select "Pressure" option.
<b>GROUP SELECTION</b> Select QUICK SETUP menu.	
<b>POS. ZERO ADJUST</b> Due to orientation of the device, there may be a shift in the measured value. You correct the MEASURED VALUE via the POS. ZERO ADJUST parameter with the "Confirm" option, i.e. you assign the value 0.0 to the pressure present.	<b>POS. ZERO ADJUST</b> Due to orientation of the device, there may be a shift in the measured value. You correct the MEASURED VALUE via the POS. ZERO ADJUST parameter with the "Confirm" option, i.e. you assign the value 0.0 to the pressure present.
<b>DAMPING VALUE</b> Enter damping time (time constant $\tau$ ). The damping affects the speed at which all subsequent elements, such as the onsite display, measured value and the OUT Value of the Analog Input Block react to a change in the pressure.	<b>DAMPING VALUE</b> Enter damping time (time constant $\tau$ ). The damping affects the speed at which all subsequent elements, such as the onsite display, measured value and the OUT Value of the Analog Input Block react to a change in the pressure.

For onsite operation, see also → [29](#), Section 6.2.3 "Function of the operating elements – onsite display connected" and → [31](#), Section 6.4 "Local operation – onsite display connected".

## 7.9 Scaling the OUT parameter

See operating instructions.



71336239

[www.addresses.endress.com](http://www.addresses.endress.com)

---