

PM LEGACY™

PM3 PID Controller User Guide



For Configurations:

PM3__ [A,C,E,F,K] [A,C,J,K] - AAAN __



1241 Bundy Boulevard., Winona, Minnesota USA 55987
Phone: +1 (507) 454-5300, Fax: +1 (507) 452-4507
<http://www.watlow.com>



Warranty

The PM3 LEGACY™ PID is manufactured by ISO 9001-registered processes and is backed by a three-year warranty to the first purchaser for use, providing that the units have not been misapplied. Since Watlow has no control over their use, and sometimes misuse, we cannot guarantee against failure. Watlow's obligations hereunder, at Watlow's option, are limited to replacement, repair or refund of purchase price, and parts which upon examination prove to be defective within the warranty period specified. This warranty does not apply to damage resulting from transportation, alteration, misuse or abuse. The purchaser must use Watlow parts to maintain all listed ratings.

Technical Assistance

If you encounter a problem with your Watlow controller, review your configuration information to verify that your selections are consistent with your application: inputs, outputs, alarms, limits, etc. If the problem persists, you can get technical assistance from your local Watlow representative (see back cover), by e-mailing your questions to wintechsupport@watlow.com or by dialing +1 (507) 494-5656 between 7 a.m. and 5 p.m., Central Standard Time (CST). Ask for an Applications Engineer. Please have the following information available when calling:

- Complete model number
- All configuration information
- User's Guide
- Factory Page

Return Material Authorization (RMA)

1. If you are an End User, and this PM is installed in an OEM System, please contact the OEM to get the PM repaired. If you are an OEM or Watlow Distributor, please go to www.watlow.com/rma to start the RMA process. Watlow Customer Service will then respond back with the RMA number via an e-mail.
2. A Return Merchandise Authorization number from the Customer Service Department is required when returning any product for credit, repair or evaluation. Make sure the Return Merchandise Authorization number is on the outside of the carton and on all paperwork returned. Ship on a Freight Prepaid basis.
3. After we receive your return, we will examine it and try to verify the reason for returning it.
4. In cases of manufacturing defect, we will enter a repair order, replacement order or issue credit for material returned. In cases of customer misuse, we will provide repair costs and request a purchase order to proceed with the repair work.
5. To return products that are not defective, goods must be in new condition, in the original boxes and they must be returned within 60 days of receipt. A 35 percent restocking charge is applied for all returned stock controls and accessories.
6. If the unit cannot be repaired, you will receive a letter of explanation and be given the option to have the unit returned to you at your expense or to have us scrap the unit.
7. Watlow reserves the right to charge for no trouble found (NTF) returns.

Copyrights

This PM3 LEGACY™ PID User's Guide is copyrighted by Watlow Electric, Inc., © October 2020 with all rights reserved.



Table of Contents

Warranty	2
Technical Assistance	2
Return Material Authorization (RMA)	2
Table of Contents	3
Safety Information	7
Chapter 1: Overview	9
Available PM3 LEGACY™ PID Literature and Resources	9
Introduction	10
Getting Started Quickly	12
A Conceptual View of the PM	13
Inputs	13
Internal Functions	13
Outputs	14
Input Events and Output Events	14
What is a Profile	14
Chapter 2: Install and Wire	16
Installation	16
Dimensions	17
1/32 DIN	17
Wiring	18
PM3 LEGACY™ PID Isolation Blocks	20
Chapter 3: Keys and Displays	34
Responding to a Displayed Message	35
Chapter 4: Home Page	36
Default Home Page Parameters	36
Navigating the PM3 LEGACY™ PID Controller	37
Changing the Set Point	37
Starting a Profile from the Home Page	37
Modifying the Display Pairs	39
Conventions Used in the Menu Pages	41
Display	42
Range	42
Modbus RTU Protocols	42

Table of Contents (cont.)

Chapter 5: Operations Page	44
Analog Input Menu	46
Linearization Menu	47
Process Value Menu	48
Digital Input/Output Menu	48
Monitor Menu	49
Control Loop Menu	50
Alarm Menu	53
Timer Menu	54
Profile Status Menu	57
Chapter 6: Setup Page	59
Analog Input Menu	62
Linearization Menu	65
Process Value Menu	68
Digital Input/Output Menu	69
Control Loop Menu	72
Output Menu	78
Alarm Menu	81
Timer Menu	85
Global Menu	87
Communications Menu	89
Standard Bus	90
Modbus RTU	90
Chapter 7: Profiling Page	92
Profile Setup	92
Profiling Menu	97
Chapter 8: Factory Page	102
Custom	103
Lock Menu	104
Unlock Menu	106
Diagnostics Menu	107
Calibration Menu	108
Chapter 9: Features	110
Changing PM Model Number to PM Express	112
Saving and Restoring Settings	114
Programming the Home Page	114

Table of Contents (cont.)

Tuning the PID Parameters	114
Autotune	114
Manual Tuning	115
Autotuning with TRU-TUNE+®	116
Inputs	117
Calibration Offset	117
Calibration	117
Filter Time Constant	119
Sensor Selection	119
Set Point Minimum and Maximum	119
Scale High and Scale Low	120
Range High and Range Low	120
Ten Point Linearization	120
Outputs	121
Duplex	121
Retransmitting a Process Value or Set Point	121
Cool Output Curve	122
Control Methods	122
Output Configuration	122
Auto (closed loop) and Manual (open loop) Control	122
On-Off Control	123
Proportional and (P) Control	124
Proportional and Integral (PI) Control	124
Proportional, Integral and Derivative (PID) Control	125
Dead Band	125
Variable Time Base	125
Single Set Point Ramping	126
Timer Function	127
Setting Up the Timer Function	128
Alarms	130
Process and Deviation Alarms	130
Set Points	130
Hysteresis	130
Latching	130
Silencing	131
Blocking	131
Open Loop Detection	131



Table of Contents (cont.)

Using Lockout and Password Security	131
Using Lockout Method 1 (Read and Set Lock)	132
Using Lockout Method 2 (Password Enable)	134
Modbus - Using Programmable Memory Blocks	135
Software Configuration	136
Using PM3 LEGACY™ PID Configurator Software	136
Chapter 10: Appendix	140
Troubleshooting Alarms, Errors and Control Issues	140
Modbus - Programmable Memory Blocks	146
PM Specifications	149
Ordering Information for PID Controller Models	154
Declaration of Conformity	155
How to Reach Us.	156

Safety Information











We use note, caution and warning symbols throughout this book to draw your attention to important operational and safety information.



A “NOTE” marks a short message to alert you to an important detail.

A “CAUTION” safety alert appears with information that is important for protecting your equipment and performance. Be especially careful to read and follow all cautions that apply to your application.

A “WARNING” safety alert appears with information that is important for protecting you, others and equipment from damage. Pay very close attention to all warnings that apply to your application.

The electrical hazard symbol,  (a lightning bolt in a triangle) precedes an electric shock hazard CAUTION or WARNING safety statement.

Symbol	Explanation
	CAUTION – Warning or Hazard that needs further explanation than label on unit can provide. Consult User's Guide for further information.
	ESD Sensitive product, use proper grounding and handling techniques when installing or servicing product.
	Unit protected by double/reinforced insulation for shock hazard prevention.
	Do not throw in trash, use proper recycling techniques or consult manufacturer for proper disposal.
	Enclosure made of Polycarbonate material. Use proper recycling techniques or consult manufacturer for proper disposal.
	Unit can be powered with either alternating current (ac) voltage or direct current (dc) voltage.
	Unit is a Listed device per Underwriters Laboratories®. It has been evaluated to United States and Canadian requirements for Process Control Equipment. UL 61010 and CSA C22.2 No. 61010. File E185611 QUYX, QUYX7. See: www.ul.com
	Unit is a Listed device per Underwriters Laboratories®. It has been evaluated to United States and Canadian requirements for Hazardous Locations Class 1 Division II Groups A, B, C and D. ANSI/ISA 12.12.01-2007. File E184390 QUZW, QUZW7. See: www.ul.com
	Unit is compliant with European Union directives. See Declaration of Conformity for further details on Directives and Standards used for Compliance.
	Unit has been reviewed and approved by Factory Mutual as a Temperature Limit Device per FM Class 3545 standard. See: www.fmglobal.com

	<p>Unit has been reviewed and approved by CSA International for use as Temperature Indicating-Regulating Equipment per CSA C22.2 No. 24. See: www.csa-international.org</p>
	<p>Unit has been reviewed and approved by ODVA for compliance with DeviceNet communications protocol. See: www.odva.org</p>
	<p>Unit has been reviewed and approved by ODVA for compliance with Ethernet/IP communications protocol. See: www.odva.org</p>

1

Chapter 1: Overview

Available PM3 LEGACY™ PID Literature and Resources

Document Title and Part Number	Description
Contact Watlow Directly:	For technical assistance contact Watlow at: www.watlow.com Or call at: 1-800-WATLOW2 Or (1-800-928-5692) Or e-mail at: wintechsupport@watlow.com
PM3 LEGACY™ PID Controller Quick Start Guide Document No. 10-43056 Part No. 2152-6956	A Quick Start Guide to help you get your controller set up is available for download at https://www.watlow.com/resources-and-support/Technical-Library/ .
PM LEGACY™ Series Panel Mount Controller Specification Sheet	This Specifications Sheet describes the PM LEGACY™ Series hardware options, features, benefits and technical specifications. Available at: https://www.watlow.com/resources-and-support/Technical-Library/

All of the user documentation described above can be found on the Watlow website.

Click on the following link to find your document of choice:

<http://www.watlow.com/literature/index.cfm>. Once there, simply type in the desired part number (or name) into the search box and download free copies. Printed versions of all user documents can also be purchased here as well.

Your Comments are Appreciated

In an effort to continually improve our technical literature and ensure that we are providing information that is useful to you, we would very much appreciate your comments and suggestions. Please send any comments you may have to the following e-mail address:

TechlitComments@watlow.com

Introduction

The PM3 LEGACY™ PID takes the pain out of solving your thermal loop requirements. Watlow's PM3 LEGACY™ PID controllers offer options to reduce system complexity and the cost of control loop ownership. You can order the PM3 LEGACY™ PID as a PID controller.



Features and Benefits

PID auto-tune

- Provides auto-tune for fast, efficient start-up

Standard bus communications

- Allows easy product configuration via PC communications protocol and free software
- Saves time, simplifies programming process and improves reliability of controller setup

Touch-safe package

- Increases installer and operator safety
- Complies with IP2X requirements

EZ-LINK™ mobile application for iPhone® and Android™

- Expedites controller setup with intuitive navigation
- Simplifies setting parameters with plain text names and descriptions
- Connects quickly and easily via Bluetooth® wireless communications

Features and Benefits (Continued)

SMOOTH TOUCH™ keypad

- Eliminates contamination points on the front of the controller
- Prevents premature failure of mechanical components
- Creates a better seal on front panel
- Ensures an easy to clean surface

Agency approvals: UL® listed, CSA, CE, RoHS, W.E.E.E., FM, SEMI F47-0200, Class 1, Div. 2 rating on selected models

- Assures prompt product acceptance
- Reduces end product documentation costs

P3T armor sealing system

- Compiles to NEMA 4X, IP66 and IP67 specifications
- Allows controller to be cleaned and washed
- Certified UL® 50 independent to NEMA 4X specification

Consistent Termination Labeling (CTL) connection system





- Simplifies switching between products
- Speeds up user's system documentation

Three-year warranty

- Demonstrates Watlow's reliability and product support

Getting Started Quickly

The PM control has a page and menu structure that is listed below along with a brief description of its purpose.

<p>Setup Page Push and hold the up and down keys   for 6 seconds to enter. (See the Setup Page for further information)</p>	<p>Once received, a user would want to setup their control prior to operation. As an example, define the input type and set the output cycle time.</p>
<p>Operations Page Press and hold the up and down keys   for 3 seconds to enter. (See the Operations Page for further information)</p>	<p>After setting up the control to reflect your equipment, the Operations Page would be used to monitor or change runtime settings. As an example, the user may want to see how much time is left in a profile step or perhaps change the high set point of the limit.</p>
<p>Factory Page Press and hold the Infinity and the green Advance Keys for 6 seconds to enter. (See the Factory Page for further information)</p>	<p>For the most part the Factory Page has no bearing on the control when running. A user may want to enable password protection, view the control part number or perhaps create a custom Home Page.</p>
<p>Home Page The control is at the Home Page when initially powered up.</p>	<p>Pushing the green Advance Key  will allow the user to see and change such parameters as the control mode, enable autotune and idle set point, to name a few.</p>

The default PM loop configuration from the factory is shown below:

- Analog Input functions set to thermocouple, type J
- Heat algorithm set for PID, Cool set to off
- Output 1 set to Heat
- Control mode set to Auto
- Set point set to 75 °F

If you are using the input type shown above, simply connect to input and output devices the control. Power up the control and push the up arrow  on the face of the control to change the set point from the default value of 75°F to the desired value. As the Set Point increases above the Process Value, output 1 will come on and it will now begin driving your output device.

Note: The output cycle time will have a bearing on the life of mechanical relay outputs and can be different based on the type of output ordered. The output cycle time can be changed in the Setup Page under the Output Menu.

PM LEGACY™ PID Default Configuration

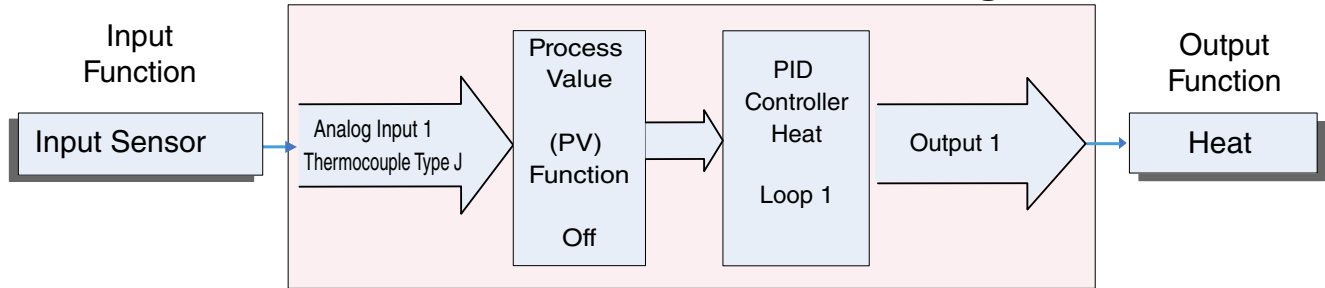

A Conceptual View of the PM

The flexibility of the PM's software and hardware allows a large range of configurations. Acquiring a better understanding of the controller's overall functionality and capabilities while at the same time planning out how the controller can be used will deliver maximum effectiveness in your application.

It is useful to think of the controller in three parts: inputs; procedures; and outputs. Information flows from an input to a procedure to an output when the controller is properly configured. A single PM controller can carry out several procedures at the same time, for instance closed-loop control, monitoring for several different alarm situations and operating switched devices, such as lights and motors. Each process needs to be thought out carefully and the controller's inputs, procedures and outputs set up properly.

Inputs

The inputs provide the information that any given programmed procedure can act upon. In a simple form, this information may come from an operator pushing a button or from a sensor monitoring the temperature of a part being heated or cooled.

Each analog input typically uses a thermocouple or RTD to read the process temperature. It can also read volts, current or resistance, allowing it to use various devices to read a wide array of values.

A PM with digital input/output (DIO) hardware includes two sets of terminals where each of which can be used as either an input or an output. Each pair of terminals must be configured to function as either an input or output with the direction parameter in the Digital Input/Output Menu (Setup Page). Each digital input reads whether a device is active or inactive.

Internal Functions

The controller will use input signals to calculate a value and then perform an operation. A sample of some functions may be as simple as:

- Compare an input value to the set point and calculate the optimal power for a heater
- Detect a failure of the primary sensing device and trip a contactor to remove power from the heating element
- Reading a digital input to set a state to true or false
- Evaluate an incoming temperature to determine an alarm state (on or off)

To set up a function, it's important to define the source, or instance, to use. For example, if the control is equipped with DIO they can be configured to respond to an alarm. If configured as such, the digital output must be tied to the desired alarm instance (1 to 4). Using this as an example, the Function for the digital output would be defined as an Alarm where the Instance would be selected as 1, 2, 3, or 4 corresponding to the alarm instance that will drive the output.

Keep in mind that a function is a user-programmed internal process that does not execute any action outside of the controller. To have any effect outside of the controller, an output must be configured to respond to a function.

Outputs

Outputs can perform various functions or actions in response to information provided by a function such as, removal of the control voltage to a contactor; operating a heater, turning a light on or off, unlocking a door, etc..

Assign a Function to any available output on the Setup Page within the Output Menu or Digital Input/Output Menu. Then select which instance of that function will drive the selected output. For example, you might assign an output to respond to alarm 4 (instance 4).

You can assign more than one output to respond to a single instance of a function. For example, alarm 2 could be used to trigger a light connected to output 1 and a siren connected to digital output 5.

Input Events and Output Events

Input and output events are internal states that are used exclusively by profiles. The source of an event input can come from a real-world digital input or an output from another function. Likewise, event outputs may control a physical output such as an output function block or be used as an input to another function.

What is a Profile

A profile is a set of instructions consisting of a sequence of steps. When a profile runs, the controller automatically executes its steps in sequence. The step type determines what action the controller performs. Steps can change temperatures and other process values gradually over time, maintain the temperatures and process values for specific periods, or repeat a sequence of steps numerous times. At each step the profile can activate or deactivate outputs that control other equipment. Also a step can have the controller wait for specific conditions before proceeding such as, waiting for a switch closure and/or a specific process value to be detected by a sensor.

PM LEGACY™ PID Model System Diagram

Universal Sensor Input, Configuration Communications,
Red/Green 7-Segment Display

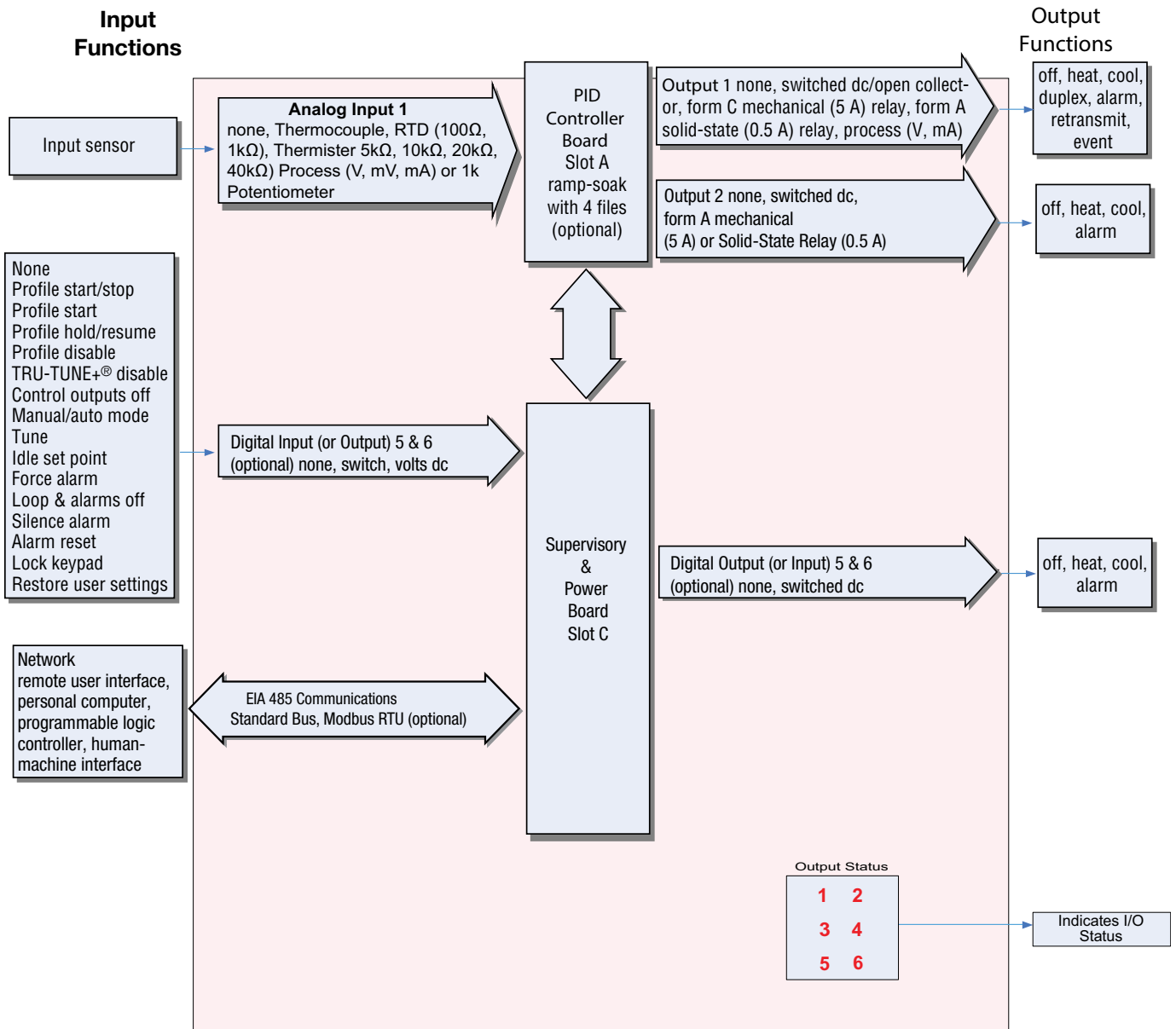

2

Chapter 2: Install and Wire

Installation

1. Make the panel cutout using the measurements in figure 1.
2. Remove the green terminal connectors and the mounting collar assembly.
3. Insert the controller into the panel cutout from the front.
4. Orient the collar base so the flat side faces front and the screw openings are on the sides (see figure 2), then slide the base over the back of the controller.
5. Slide the mounting bracket over the controller with the screws aligned to the collar base. Push the bracket gently but firmly until the hooks snap into the slots in the case.
6. Tighten the two #6-19 x 1.5 in. screws with a phillips screwdriver until the device is flush to the panel (3 to 4 in-lbs torque).
7. Reinstall the terminal connectors to their original locations. (Or first connect field wiring as indicated in this guide and then reinstall the connectors).

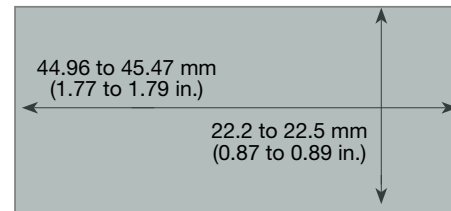

Figure 1

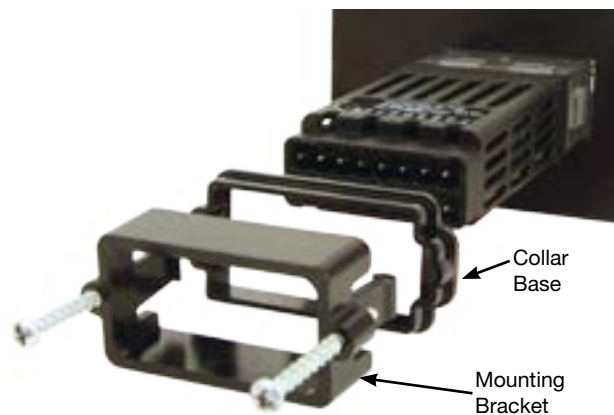

Figure 2

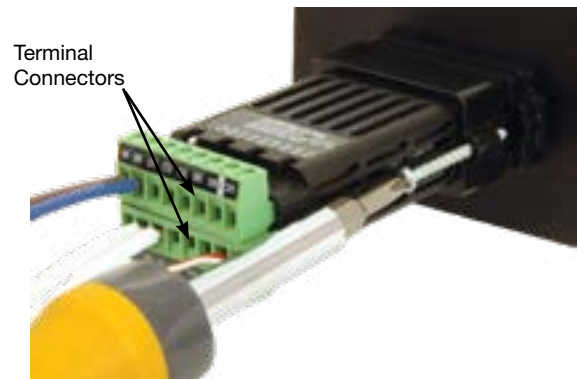

Figure 3

Chemical Compatibility

This product is compatible with acids, weak alkalis, alcohols, gamma radiation and ultra-violet radiation. This product is not compatible with strong alkalis, organic solvents, fuels, aromatic hydrocarbons, chlorinated hydrocarbons, esters and keytones.

WARNING!

All electrical power to the controller and controlled circuits must be disconnected before removing the controller from the front panel or disconnecting other wiring. Failure to follow these instructions may cause an electrical shock and/or sparks that could cause an explosion in class 1, div. 2 hazardous locations.

Dimensions 1/32 DIN

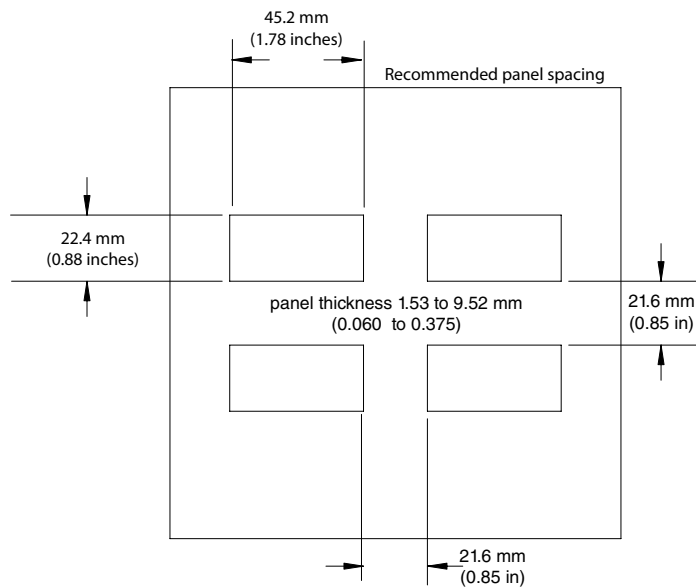
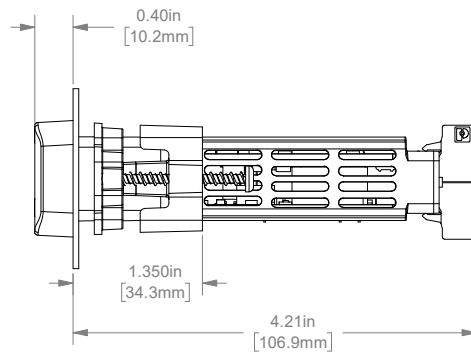
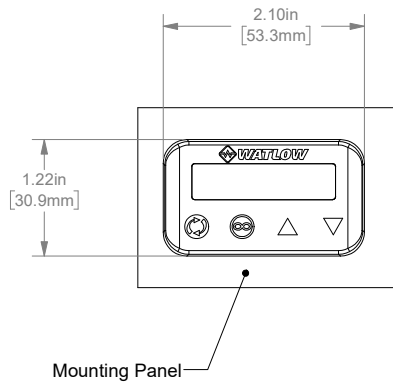
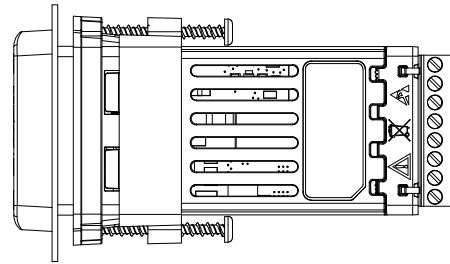

Wiring

Terminal Definitions for Slots A

Slot A		Terminal Function	Configuration
Inputs		Universal, RTD and Thermistor Inputs	
T1		S2 (RTD) or current +	Input 1: all configurations
S1		S3 (RTD), thermocouple -, current -, potentiometer wiper, thermistor or volts -	
R1		S1 (RTD), thermocouple +, volts +, potentiometer or thermistor	
Outputs		Switched dc/open collector	
1	2		
X1		common (Any switched dc output can use this common.)	PM3 __ [C] __ AAAN __
W1		dc- (open collector)	
Y1		dc+	
		Switched dc	
	W2	dc-	PM3 ___ [C] _ AAAN __
	Y2	dc+	
		Universal Process	
F1		voltage or current -	PM3 __ [F] __ AAAN __
G1		voltage +	
H1		current +	
		Mechanical Relay 5 A, Form C	
L1		normally open	PM3 __ [E] __ AAAN __
K1		common	
J1		normally closed	
		Mechanical Relay 5 A, Form A	
	L2	normally open	PM3 ___ [J] _ AAAN __
	K2	common	
		Solid-State Relay 0.5 A, Form A	
L1	L2	normally open	PM3 __ [K] __ AAAN __
K1	K2	common	PM3 ___ [K] _ AAAN __

Terminal Definitions for Slot C

Slot C	Terminal Function	Configuration
Power		
98	Power input: ac or dc+	all
99	Power input: ac or dc-	
Standard Bus		
CF	Standard Bus EIA-485 common	PM3 _ _ _ _ [A,B] AAAN _ _
CD	Standard Bus EIA-485 T-/R-	
CE	Standard Bus EIA-485 T+/R+	
Standard Bus or Modbus EIA-485		
CC	Standard Bus or Modbus RTU EIA-485 common	PM3 _ _ _ _ [1,E]AAAN _ _
CA	Standard Bus or Modbus RTU EIA-485 T-/R-	
CB	Standard Bus or Modbus RTU EIA-485 T+/R+	
Digital Input/Output		
B5	Digital input-output common	PM3 _ [2] _ _ _ AAAN _ _
D6	Digital input or output 6	
D5	Digital input or output 5	PM3 _ [4] _ _ _ AAAN _ _

Slot Orientation - Back View

1/32 DIN - (PM3)

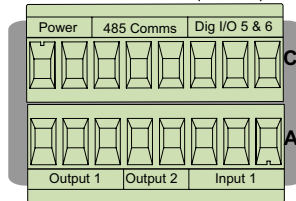

PM3 LEGACY™ PID PM Isolation Blocks

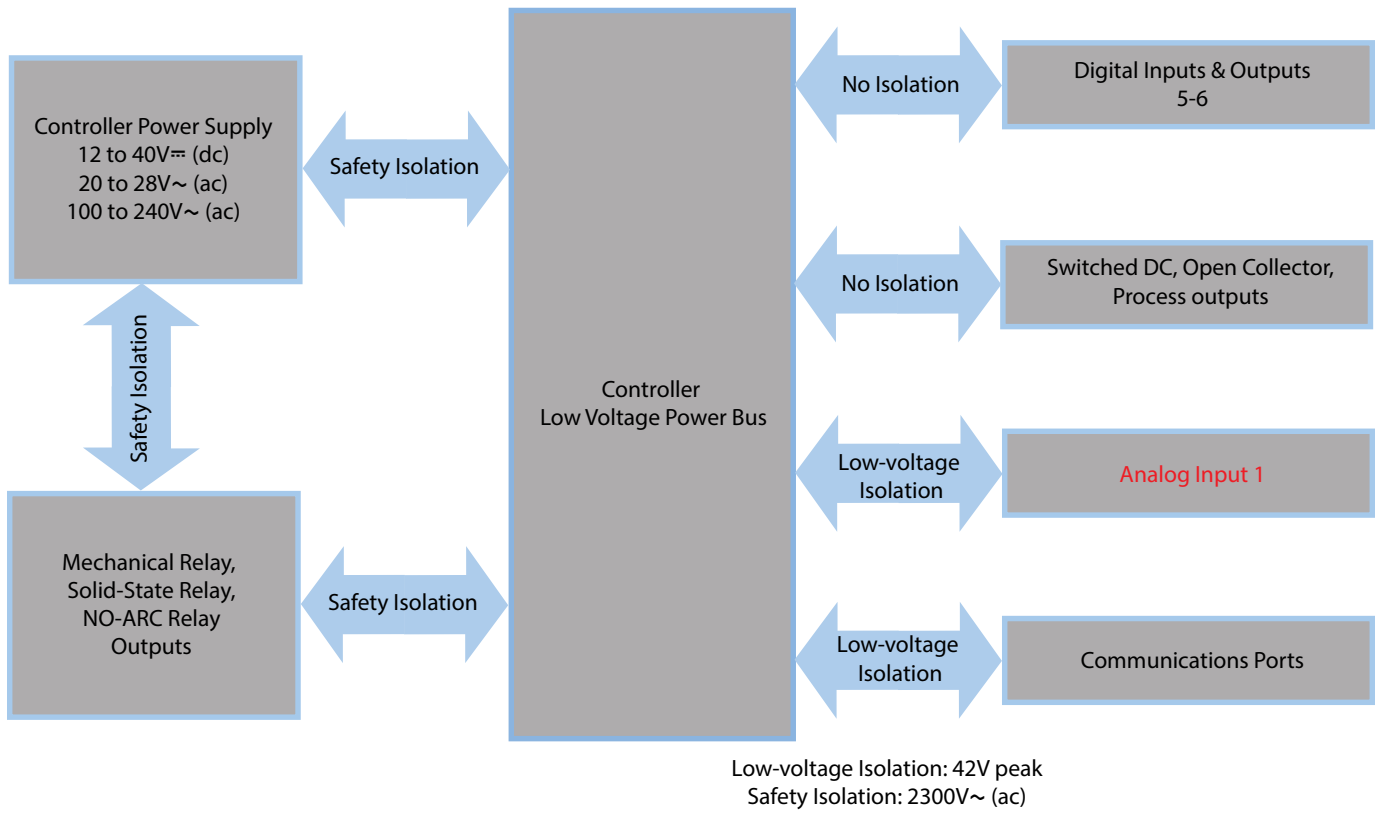

Warning: 

Use National Electric (NEC) or other country-specific standard wiring and safety practices when wiring and connecting this controller to a power source and to electrical sensors or peripheral devices. Failure to do so may result in damage to equipment and property, and/or injury or loss of life.

Note:

Maximum wire size termination and torque rating:

- 0.0507 to 3.30 mm² (30 to 12 AWG) single-wire termination or two 1.31 mm² (16 AWG)
- 0.56 Nm (5.0 in-lb.) torque

Note:

Adjacent terminals may be labeled differently, depending on the model number.

Note:

To prevent damage to the controller, do not connect wires to unused terminals.

Note:

Analog Input 1 is always isolated in this model.

Note:

This equipment is suitable for use in CLASS I, DIVISION 2, Groups A, B, C and D or Non-Hazardous locations only. Temperature Code T4A

Warning: 

Explosion Hazard - Dry contact closure Digital Inputs shall not be used in Class I Division 2 Hazardous Locations unless switch used is approved for this application.

Warning: 

Explosion Hazard – Substitution of component may impair suitability for CLASS I, DIVISION 2.

Warning: 

Explosion Hazard - Do not disconnect while the circuit is live or unless the area is known to be free of ignitable concentrations of flammable substances.

Low Power

PM3_ [3,4] _ _ _ AAAN _ _

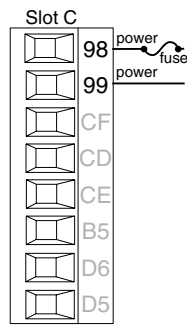

- Minimum/Maximum Ratings
- 12 to 40V $\overline{=}$ (dc)
- 20 to 28V \sim (ac) Semi Sig F47
- 47 to 63 Hz
- 10VA maximum power consumption (PM6)

High Power

PM3 _ [1,2] _ _ _ AAAN _ _

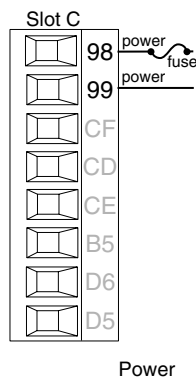

- Minimum/Maximum Ratings
- 85 to 264V \sim (ac)
- 100 to 240V \sim (ac) Semi Sig F47
- 47 to 63 Hz
- 10VA maximum power consumption

Digital Input 5, 6

PM3 _ [2,4] _ _ _ AAAN _ _

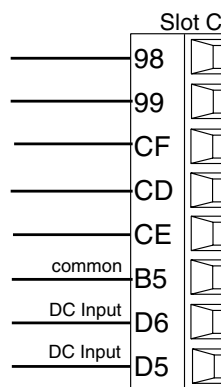

Digital Input

- Update rate 10 Hz
- Dry contact or dc voltage

DC Voltage

- Input not to exceed 36V $\overline{=}$ (dc) at 3mA
- Input active when > 3V $\overline{=}$ (dc) @ 0.25 mA

- Input inactive when < 2V

Dry Contact

- Input inactive when > 500 Ω
- Input active when < 100 Ω
- Maximum short circuit 13mA

Voltage Input

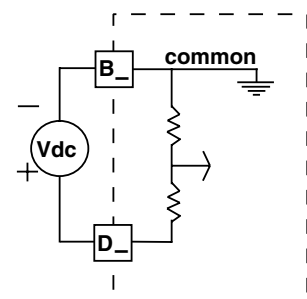

Dry Contact

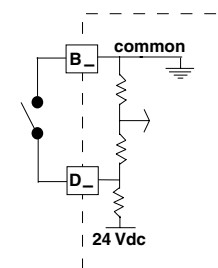

Warning: ⚠

Use National Electric (NEC) or other country-specific standard wiring and safety practices when wiring and connecting this controller to a power source and to electrical sensors or peripheral devices. Failure to do so may result in damage to equipment and property, and/or injury or loss of life.

Note:

Maximum wire size termination and torque rating:

- 0.0507 to 3.30 mm² (30 to 12 AWG) single-wire termination or two 1.31 mm² (16 AWG)
- 0.56 Nm (5.0 in-lb.) torque

Note:

Adjacent terminals may be labeled differently, depending on the model number.

Note:

To prevent damage to the controller, do not connect wires to unused terminals.

Note:

Analog Input 1 is always isolated in this model.

Note:

This equipment is suitable for use in CLASS I, DIVISION 2, Groups A, B, C and D or Non-Hazardous locations only. Temperature Code T4A

Warning: ⚠

Explosion Hazard - Dry contact closure Digital Inputs shall not be used in Class I Division 2 Hazardous Locations unless switch used is approved for this application.

Warning: ⚠

Explosion Hazard – Substitution of component may impair suitability for CLASS I, DIVISION 2.

Warning: ⚠

Explosion Hazard - Do not disconnect while the circuit is live or unless the area is known to be free of ignitable concentrations of flammable substances.

Input 1 Thermocouple

PM3 [C,R,T] _ _ _ _ _ AAAN _ _

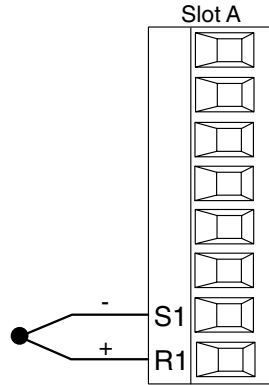

- 2kΩ maximum source resistance
- >20MΩ input impedance
- 3μA open-sensor detection
- Thermocouples are polarity sensitive. The negative lead (usually red) must be connected to S1.
- To reduce errors, the extension wire for thermocouples must be of the same alloy as the thermocouple.

Input 1 RTD

PM3 [C,R,T] _ _ _ _ _ AAAN _ _

2 Wire

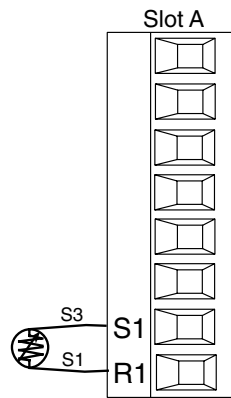

3 Wire

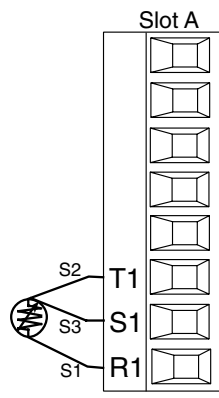

- Platinum, 100 and 1kΩ @ 0°C
- Calibration to DIN curve (0.00385 Ω/Ω/°C)
- 20Ω total lead resistance
- RTD excitation current of 0.09mA typical. Each ohm of lead resistance may affect the reading by 0.03°C.
- For 3-wire RTDs, the S1 lead (usually white) must be connected to R1.
- For best accuracy use a 3-wire RTD to compensate for lead-length resistance. All three lead wires must have the same resistance.

Input 1 Process

PM3 [C,R,T] _ _ _ _ _ AAAN _ _

Volts

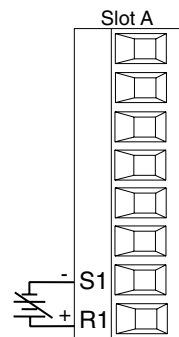

Amperes

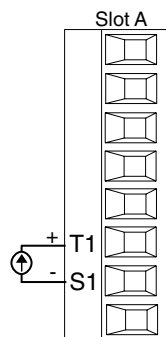

- 0 to 20mA @ 100Ω input impedance
- 0 to 10V_{DC} (dc) @ 20kΩ input impedance
- 0 to 50mV_{DC} (dc) @ 20kΩ input impedance
- Scalable

Warning: ⚠

Use National Electric (NEC) or other country-specific standard wiring and safety practices when wiring and connecting this controller to a power source and to electrical sensors or peripheral devices. Failure to do so may result in damage to equipment and property, and/or injury or loss of life.

Note:

Maximum wire size termination and torque rating:

- 0.0507 to 3.30 mm² (30 to 12 AWG) single-wire termination or two 1.31 mm² (16 AWG)
- 0.56 Nm (5.0 in-lb.) torque

Note:

Adjacent terminals may be labeled differently, depending on the model number.

Note:

To prevent damage to the controller, do not connect wires to unused terminals.

Note:

Analog Input 1 is always isolated in this model.

Note:

This equipment is suitable for use in CLASS I, DIVISION 2, Groups A, B, C and D or Non-Hazardous locations only. Temperature Code T4

Warning: ⚠

Explosion Hazard – Substitution of component may impair suitability for CLASS I, DIVISION 2.

Warning: ⚠

Explosion Hazard - Do not disconnect while the circuit is live or unless the area is known to be free of ignitable concentrations of flammable substances.

Quencharc Note:

Switching pilot duty inductive loads (relay coils, solenoids, etc.) with the mechanical relay, solid state relay or open collector output options requires use of an R.C. suppressor. Watlow Part # 0804-0147-0000.

Input 1 Potentiometer

PM3 [C,R,T] _ _ _ _ AAAN _ _

- Use a 1kΩ potentiometer

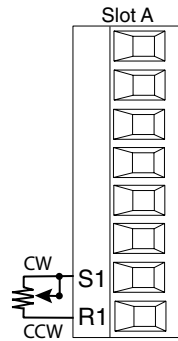

Input 1 Thermistor

PM3 [J,N] _ _ _ _ AAAN _

- >20MΩ input impedance
 - 3μA open-sensor detection
- *PM4,8 & 9 only

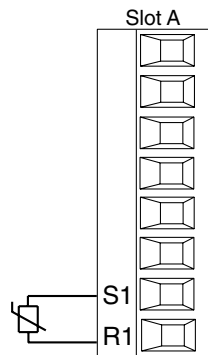

Digital Output 5, 6

PM3 _ [2,4] _ _ _ _ AAAN _ _

Digital Output

- SSR drive signal
- Update rate 10 Hz
- Maximum open circuit voltage is 22 to 25V_{DC} (dc)
- PNP transistor source
- Typical drive; 21mA @ 4.5V for DO5, and 11mA @ 4.5V for DO6
- Current limit 24mA for Output 5 and 12mA Output 6
- Output 5 capable of driving one 3-pole DIN-A-MITE
- Output 6 capable of driving one 1-pole DIN-A-MITE

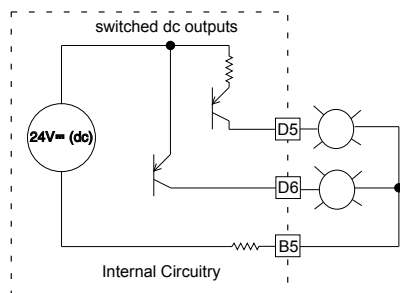
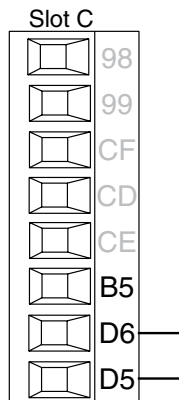

Note:

See output curves pg 24.

Warning: ⚠️

Use National Electric (NEC) or other country-specific standard wiring and safety practices when wiring and connecting this controller to a power source and to electrical sensors or peripheral devices. Failure to do so may result in damage to equipment and property, and/or injury or loss of life.

Note:

Maximum wire size termination and torque rating:

- 0.0507 to 3.30 mm² (30 to 12 AWG) single-wire termination or two 1.31 mm² (16 AWG)
- 0.56 Nm (5.0 in-lb.) torque

Note:

Adjacent terminals may be labeled differently, depending on the model number.

Note:

To prevent damage to the controller, do not connect wires to unused terminals.

Note:

Analog Input 1 is always isolated in this model.

Note:

This equipment is suitable for use in CLASS I, DIVISION 2, Groups A, B, C and D or Non-Hazardous locations only. Temperature Code T4

Warning: ⚠️

Explosion Hazard – Substitution of component may impair suitability for CLASS I, DIVISION 2.

Warning: ⚠️

Explosion Hazard - Do not disconnect while the circuit is live or unless the area is known to be free of ignitable concentrations of flammable substances.

Quencharc Note:

Switching pilot duty inductive loads (relay coils, solenoids, etc.) with the mechanical relay, solid state relay or open collector output options requires use of an R.C. suppressor. Watlow Part # 0804-0147-0000.

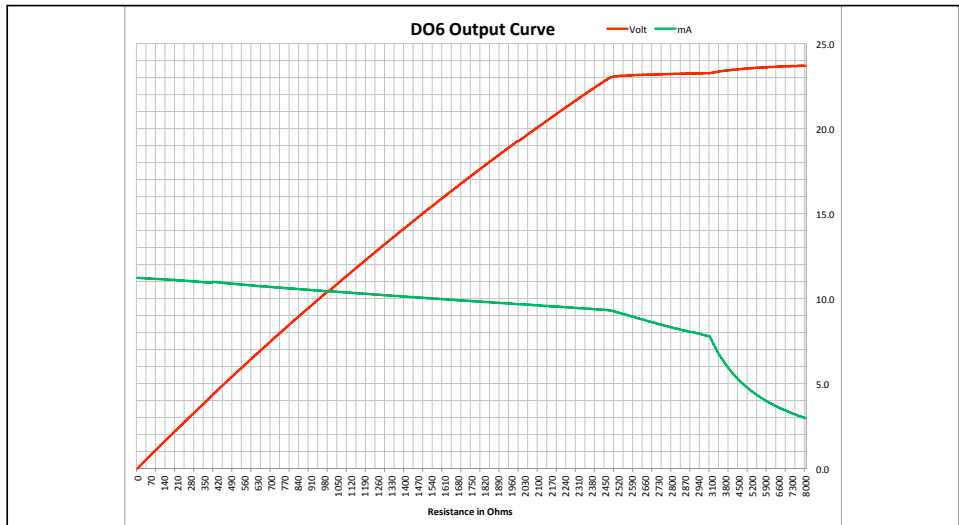
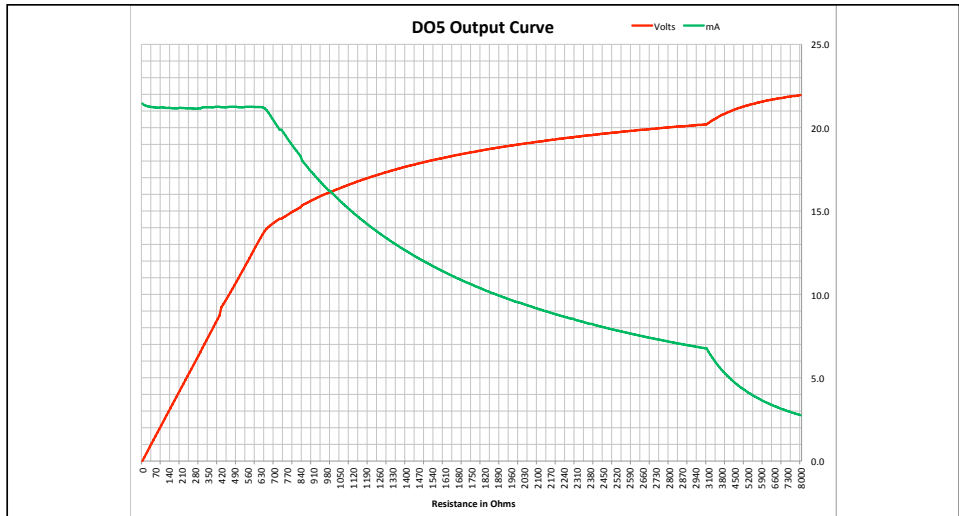

Switched DC Wiring Example Using DO 5 and 6

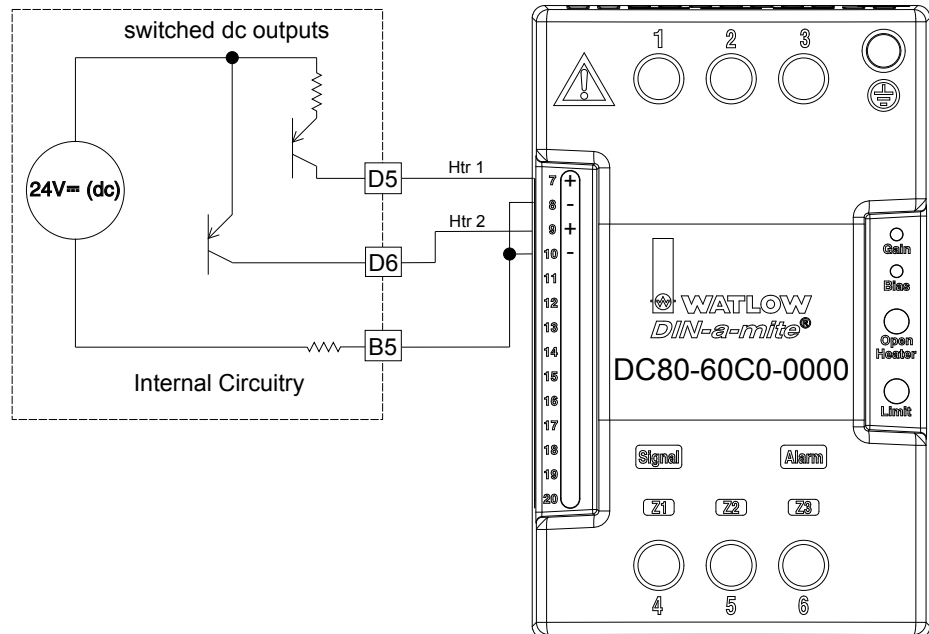

Warning: ⚠

Use National Electric (NEC) or other country-specific standard wiring and safety practices when wiring and connecting this controller to a power source and to electrical sensors or peripheral devices. Failure to do so may result in damage to equipment and property, and/or injury or loss of life.

Note:

Maximum wire size termination and torque rating:

- 0.0507 to 3.30 mm² (30 to 12 AWG) single-wire termination or two 1.31 mm² (16 AWG)
- 0.56 Nm (5.0 in-lb.) torque

Note:

Adjacent terminals may be labeled differently, depending on the model number.

Note:

To prevent damage to the controller, do not connect wires to unused terminals.

Note:

Analog Input 1 is always isolated in this model.

Note:

This equipment is suitable for use in CLASS I, DIVISION 2, Groups A, B, C and D or Non-Hazardous locations only. Temperature Code T4

Warning: ⚠

Explosion Hazard – Substitution of component may impair suitability for CLASS I, DIVISION 2.

Warning: ⚠

Explosion Hazard - Do not disconnect while the circuit is live or unless the area is known to be free of ignitable concentrations of flammable substances.

Quencharc Note:

Switching pilot duty inductive loads (relay coils, solenoids, etc.) with the mechanical relay, solid state relay or open collector output options requires use of an R.C. suppressor.

Watlow Part # 0804-0147-0000.

Output 1 Switched DC/Open Collector

PM3 _ _ [C] _ _ AAAN _ _

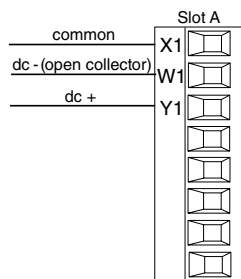

Switched DC

- Maximum open circuit voltage is 22 to 25V \approx (dc)
- 30mA max. per single output / 40mA max. total per paired outputs (1 & 2)
- Typical drive; 4.5V \approx (dc) @ 30mA
- Short circuit limited to <50mA
- NPN transistor sink
- Use dc- and dc+ to drive external solid-state relay
- 1-pole DIN-A-MITE: up to 4 in parallel or 4 in series
- 2-pole DIN-A-MITE: up to 2 in parallel or 2 in series
- 3-pole DIN-A-MITE: up to 2 in series

Open Collector

- 100mA maximum output current sink
- 30V \approx (dc) max. supply voltage
- Any switched dc output can use the common terminal.
- Use an external power supply to control a dc load, with the load positive to the positive of the power supply, the load negative to the open collector and common to the power supply negative.

See Quencharc note.

Switched DC

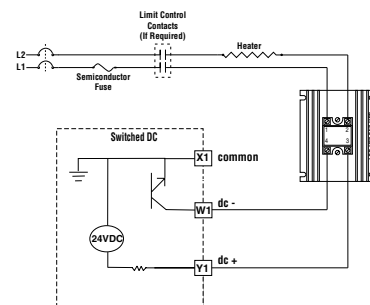

Open Collector

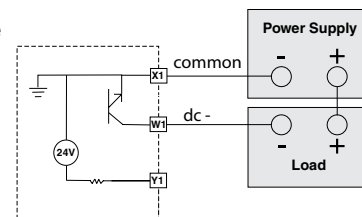

Warning: ⚠

Use National Electric (NEC) or other country-specific standard wiring and safety practices when wiring and connecting this controller to a power source and to electrical sensors or peripheral devices. Failure to do so may result in damage to equipment and property, and/or injury or loss of life.

Note:

Maximum wire size termination and torque rating:

- 0.0507 to 3.30 mm² (30 to 12 AWG) single-wire termination or two 1.31 mm² (16 AWG)
- 0.56 Nm (5.0 in-lb.) torque

Note:

Adjacent terminals may be labeled differently, depending on the model number.

Note:

To prevent damage to the controller, do not connect wires to unused terminals.

Note:

Analog Input 1 is always isolated in this model.

Note:

This equipment is suitable for use in CLASS I, DIVISION 2, Groups A, B, C and D or Non-Hazardous locations only. Temperature Code T4

Warning: ⚠

Explosion Hazard – Substitution of component may impair suitability for CLASS I, DIVISION 2.

Warning: ⚠

Explosion Hazard - Do not disconnect while the circuit is live or unless the area is known to be free of ignitable concentrations of flammable substances.

Quencharc Note:

Switching pilot duty inductive loads (relay coils, solenoids, etc.) with the mechanical relay, solid state relay or open collector output options requires use of an R.C. suppressor. Watlow Part # 0804-0147-0000.

Output 1 Mechanical Relay, Form C

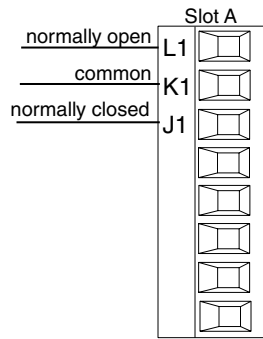

- 5A at 240V~ (ac) or 30V= (dc) maximum resistive load
- 20mA at 24V minimum load
- 125 VA pilot duty at 120/240V~ (ac), 25 VA at 24V~ (ac)
- 100,000 cycles at rated load
- Output does not supply power.
- For use with ac or dc

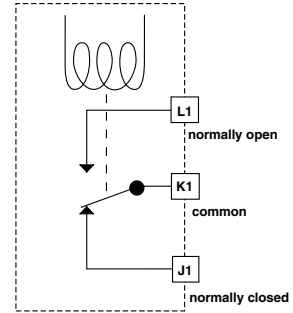

See Quencharc note.

PM3 __ [E] _ _ _
AAAN _ _

Output 1 Universal Process

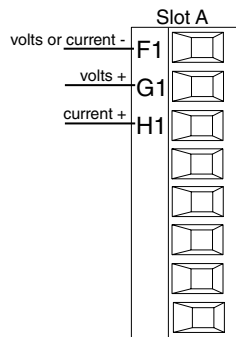

- 0 to 20mA into 800Ω maximum load
- 0 to 10V= (dc) into 1kΩ minimum load
- Scalable
- Output supplies power
- Cannot use voltage and current outputs at same time
- Output may be used as retransmit or control.

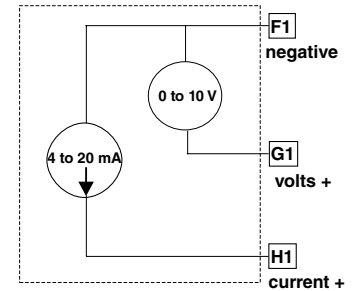

PM3 __ [F] _ _ _
AAAN _ _

Warning: ⚠

Use National Electric (NEC) or other country-specific standard wiring and safety practices when wiring and connecting this controller to a power source and to electrical sensors or peripheral devices. Failure to do so may result in damage to equipment and property, and/or injury or loss of life.

Note:

Maximum wire size termination and torque rating:

- 0.0507 to 3.30 mm² (30 to 12 AWG) single-wire termination or two 1.31 mm² (16 AWG)
- 0.56 Nm (5.0 in-lb.) torque

Note:

Adjacent terminals may be labeled differently, depending on the model number.

Note:

To prevent damage to the controller, do not connect wires to unused terminals.

Note:

Analog Input 1 is always isolated in this model.

Note:

This equipment is suitable for use in CLASS I, DIVISION 2, Groups A, B, C and D or Non-Hazardous locations only. Temperature Code T4

Warning: ⚠

Explosion Hazard – Substitution of component may impair suitability for CLASS I, DIVISION 2.

Warning: ⚠

Explosion Hazard - Do not disconnect while the circuit is live or unless the area is known to be free of ignitable concentrations of flammable substances.

Quencharc Note:

Switching pilot duty inductive loads (relay coils, solenoids, etc.) with the mechanical relay, solid state relay or open collector output options requires use of an R.C. suppressor.

Watlow Part # 0804-0147-0000.

Output 1 Solid-State Relay, Form A

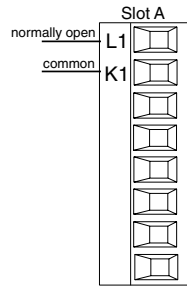

- 0.5A at 20 to 264V_A (ac) maximum resistive load
- 20VA 120/240V~ (ac) pilot duty
- Opto-isolated, without contact suppression
- Maximum off state leakage of 105µA
- Minimum holding current of 10mA
- Output does not supply power
- Do not use on dc loads.
- See Quencharc note.

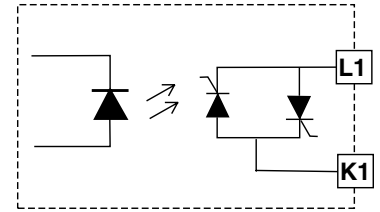

PM3 __ [K] __ AAAN

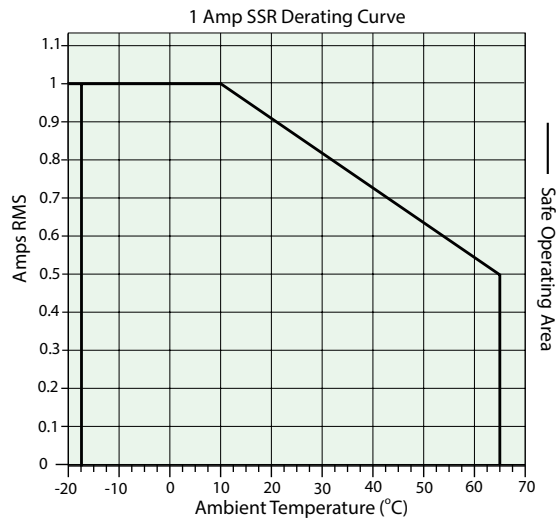

Warning: ⚠

Use National Electric (NEC) or other country-specific standard wiring and safety practices when wiring and connecting this controller to a power source and to electrical sensors or peripheral devices. Failure to do so may result in damage to equipment and property, and/or injury or loss of life.

Note:

Maximum wire size termination and torque rating:

- 0.0507 to 3.30 mm² (30 to 12 AWG) single-wire termination or two 1.31 mm² (16 AWG)
- 0.56 Nm (5.0 in-lb.) torque

Note:

Adjacent terminals may be labeled differently, depending on the model number.

Note:

To prevent damage to the controller, do not connect wires to unused terminals.

Note:

Analog Input 1 is always isolated in this model.

Note:

This equipment is suitable for use in CLASS I, DIVISION 2, Groups A, B, C and D or Non-Hazardous locations only. Temperature Code T4A

Warning: ⚠

Explosion Hazard - Dry contact closure Digital Inputs shall not be used in Class I Division 2 Hazardous Locations unless switch used is approved for this application.

Warning: ⚠

Explosion Hazard – Substitution of component may impair suitability for CLASS I, DIVISION 2.

Warning: ⚠

Explosion Hazard - Do not disconnect while the circuit is live or unless the area is known to be free of ignitable concentrations of flammable substances.

Output 2 Mechanical Relay, Form A

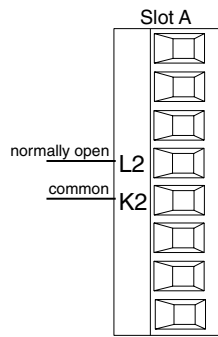

- 5A at 240V~ (ac) or 30V (dc) maximum resistive load
- 20mA at 24V minimum load
- 125VA pilot duty @ 120/240V~ (ac), 25 VA at 24V~ (ac)
- 100,000 cycles at rated load
- Output does not supply power.
- For use with ac or dc

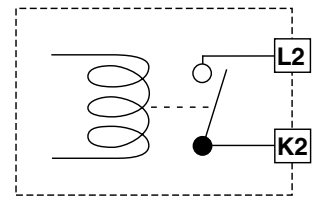

See Quencharc note.

PM3 _ _ _ [J] _ _ AAAN _ _

Output 2 Switched DC

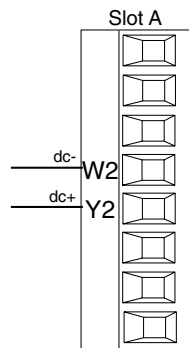

- Maximum open circuit voltage is 22 to 25V_{DC} (dc)
- 30mA max. per single output / 40mA max. total per paired outputs (1 & 2)
- Typical drive; 4.5VDC @ 30mA
- Short circuit limited to <50mA
- NPN transistor sink
- Use dc- and dc+ to drive external solid-state relay
- 1-pole DIN-A-MITE: up to 4 in parallel or 4 in series
- 2-pole DIN-A-MITE: up to 2 in parallel or 2 in series
- 3-pole DIN-A-MITE: up to 2 in series

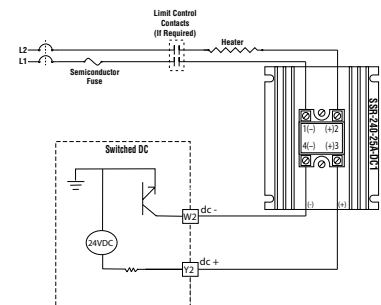

PM3 _ _ _ [C] _ _ AAAN

_ _

Warning: ⚠

Use National Electric (NEC) or other country-specific standard wiring and safety practices when wiring and connecting this controller to a power source and to electrical sensors or peripheral devices. Failure to do so may result in damage to equipment and property, and/or injury or loss of life.

Note:

Maximum wire size termination and torque rating:

- 0.0507 to 3.30 mm² (30 to 12 AWG) single-wire termination or two 1.31 mm² (16 AWG)
- 0.56 Nm (5.0 in-lb.) torque

Note:

Adjacent terminals may be labeled differently, depending on the model number.

Note:

To prevent damage to the controller, do not connect wires to unused terminals.

Note:

Analog Input 1 is always isolated in this model.

Note:

This equipment is suitable for use in CLASS I, DIVISION 2, Groups A, B, C and D or Non-Hazardous locations only. Temperature Code T4A

Warning: ⚠

Explosion Hazard - Dry contact closure Digital Inputs shall not be used in Class I Division 2 Hazardous Locations unless switch used is approved for this application.

Warning: ⚠

Explosion Hazard – Substitution of component may impair suitability for CLASS I, DIVISION 2.

Warning: ⚠

Explosion Hazard - Do not disconnect while the circuit is live or unless the area is known to be free of ignitable concentrations of flammable substances.

Output 2 Solid-State Relay, Form A

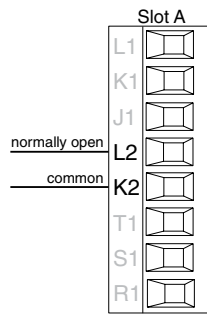

- 0.5A at 20 to 264V~ (ac) maximum resistive load
- 20VA 120/240V~ (ac) pilot duty
- Opto-isolated, without contact suppression
- Maximum off state leakage of 105µA
- Minimum holding current of 10mA
- Output does not supply power.
- Do not use on dc loads.

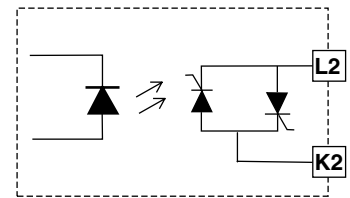

See Quencharc note.

PM3 _ _ _ [K] _ _ AAAN _ _

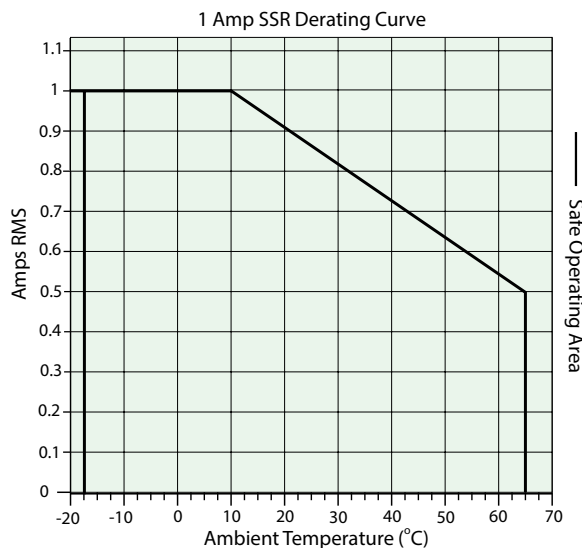

Quencharc Wiring Example

In this example the Quencharc circuit (Watlow part# 0804-0147-0000) is used to protect PM internal circuitry from the counter electromagnetic force from the inductive user load when de-energized. It is recommended that this or an equivalent Quencharc be used when connecting inductive loads to PM outputs.

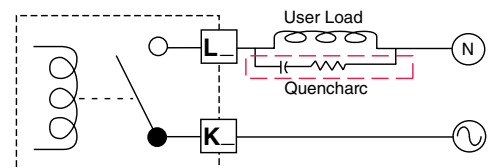

Standard Bus EIA-485 Communications

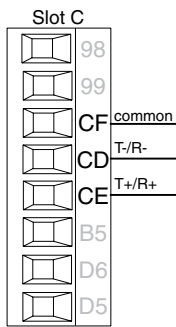

- Wire T-/R- to the A terminal of the EIA-485 port.
- Wire T+/R+ to the B terminal of the EIA-485 port.
- Wire common to the common terminal of the EIA-485 port.
- Do not route network wires with power wires. Connect network wires in daisy-chain fashion when connecting multiple devices in a network.
- Do not connect more than 16 PM3 LEGACY™ PID controllers on a network.
- Maximum network length: 1,200 meters (4,000 feet)
- 1/8th unit load on EIA-485 bus

PM3 _ _ _ _ [A,B] _ AAAN _ _

Note:

A 120Ω termination resistor may be required across T+/R+ and T-/R-, placed on the last controller on the network.

Note:

Do not leave a USB to EIA-485 converter connected to Standard Bus without power (i.e., disconnecting the USB end from the computer while leaving the converter connected on Standard Bus). Disturbance on the Standard Bus may occur.

Modbus RTU or Standard Bus EIA-485 Communications

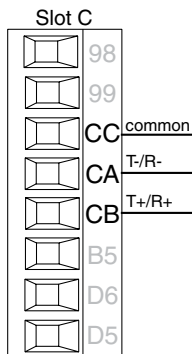

- Wire T-/R- to the A terminal of the EIA-485 port.
- Wire T+/R+ to the B terminal of the EIA-485 port.
- Wire common to the common terminal of the EIA-485 port.
- Do not route network wires with power wires. Connect network wires in daisy-chain fashion when connecting multiple devices in a network.
- A termination resistor may be required. Place a 120 Ω resistor across T+/R+ and T-/R- of last controller on network.
- Only one protocol per port is available at a time: either Modbus RTU or Standard Bus.
- Do not connect more than 16 PM3 LEGACY™ PID controllers on a Standard Bus network.
- Do not connect more than 247 PM3 LEGACY™ PID controllers on a Modbus RTU network.
- Maximum network length: 1,200 meters (4,000 feet)
- 1/8th unit load on EIA-485 bus.

PM3 _ _ _ _ [1,E] _ AAAN _ _

Modbus-IDA Terminal	EIA/TIA-485 Name	Watlow Terminal Label	Function
DO	A	CA or CD	T-/R-
D1	B	CB or CE	T+/R+
common	common	CC or CF	common

Note:

When connecting the USB converter to the PC it is suggested that the Latency Timer be changed from the default of 16 msec to 1 msec. Failure to make this change may cause communication loss between the PC running EZ-ZONE Configurator software and the control.

To modify Latency Timer settings follow the steps below:

1. Navigate to Device Manager.
2. Double click on Ports.
3. Right click on the USB serial port in use and select Properties.
4. Click the tab labeled Port settings and then click the Advance button.

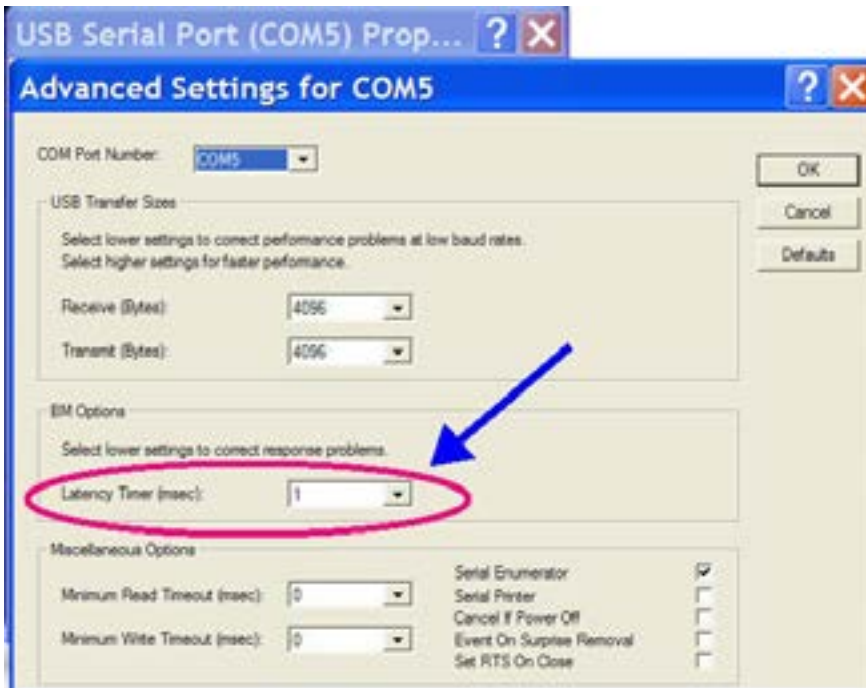

3



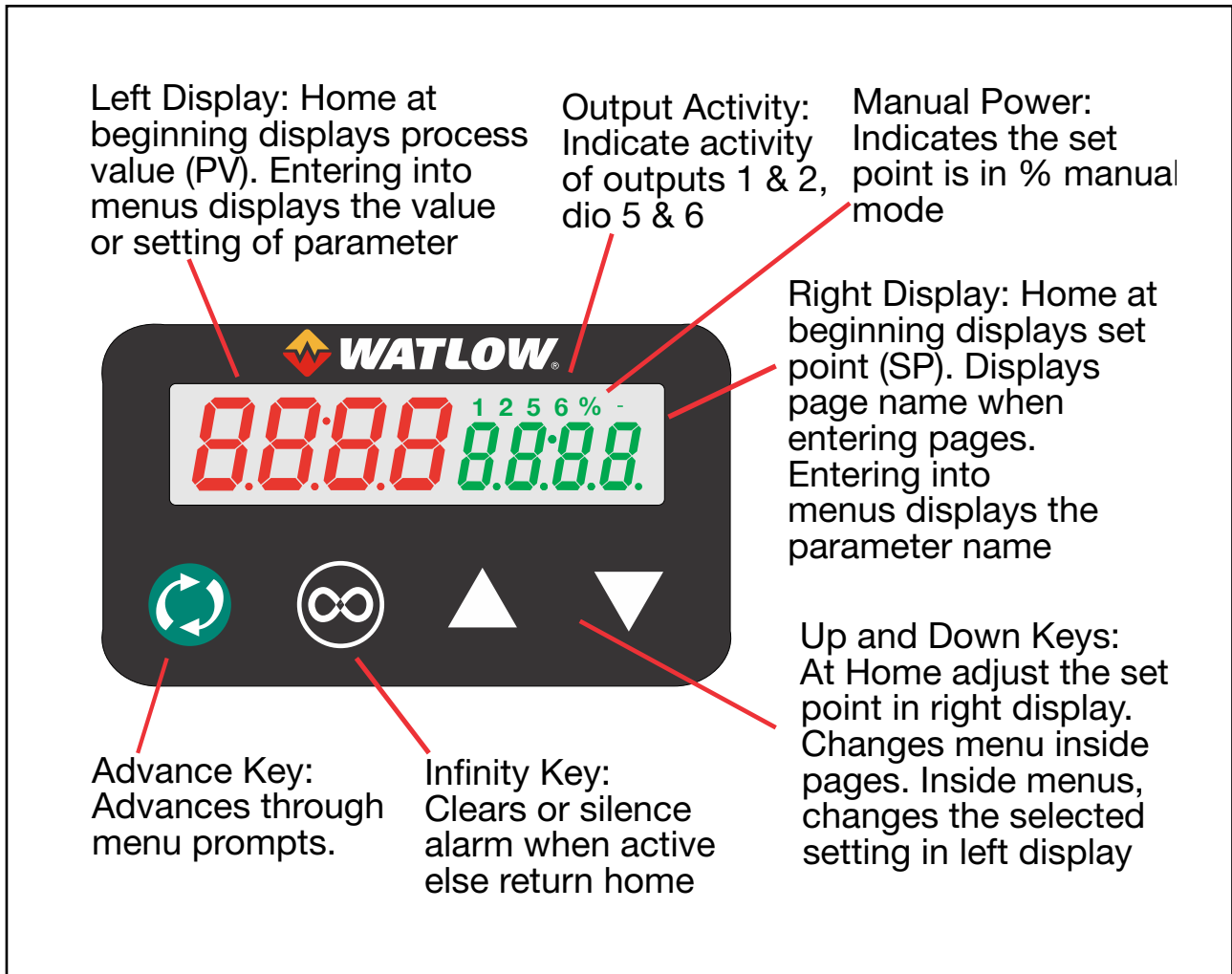

Chapter 3: Keys and Displays









Responding to a Displayed Message

An active message will cause the display to toggle between the normal settings and the active message in the red display and *Attn* in the green display.

Your response will depend on the message and the controller settings. Some messages, such as Ramping and Tuning, indicate that a process is underway. If the message was generated by a latched alarm and the condition no longer exists or if an alarm has silencing enabled it can be silenced simply by pushing the Infinity  key. Alternatively, use the method below to view all and then clear.

Push the Advance Key  to display *Err* in the red display and the message source (such as *ALH 1*) in the green display. Use the Up  or Down  keys to scroll through possible responses, such as Clear *CLR* or Silence *SIL*, then push the Advance  or Infinity  key to execute the action. See the Home Page for further information on the Attention Codes.



Display	Parameter Name Description	Range	Appears If
<i>Attn</i>	<p>Attention An active message will cause the display to toggle between the normal settings and the active message in the red display and <i>Attn</i> in the green display. Your response will depend on the message and the controller settings. Some messages, such as Ramping and Tuning, indicate that a process is underway. If the message was generated by a latched alarm, the message can be cleared when the condition no longer exists. If an alarm has silencing enabled, it can be silenced.</p> <ol style="list-style-type: none"> 1. Push the Advance Key  to display <i>Err</i> in the red display and the message source (such as <i>ALH 1</i>) in the green display. 2. Use the Up  and Down  keys to scroll through possible responses, such as Clear <i>CLR</i> or Silence <i>SIL</i>. 3. Press the Advance Key  or Infinity  key to execute the action. <p>Alternatively, rather than scrolling through all messages simply push the Infinity  button to generate a clear.</p>	<p><i>ALL 1 ALL 2 ALL 3 ALL 4</i> Alarm Low 1 to 4</p> <p><i>ALH 1 ALH 2 ALH 3 ALH 4</i> Alarm High 1 to 4</p> <p><i>ALE 1 ALE 2 ALE 3 ALE 4</i> Alarm Error 1 to 4</p> <p><i>Err 1</i> Error Input 1</p> <p><i>TUN 1</i> Tuning 1</p> <p><i>rP 1</i> Ramping 1</p> <p><i>LPo 1</i> Loop Open Error 1</p> <p><i>LPr 1</i> Loop Reversed Error 1</p> <p><i>uALH</i> Value to high to be displayed in 4 digit LED display >9999</p> <p><i>uALL</i> Value to low to be displayed in 4 digit LED display <-1999</p>	An alarm or error message is active.

4

Chapter 4: Home Page

Default Home Page Parameters

Watlow's patented user-defined menu system improves operational efficiency. The user-defined Home Page provides you with a shortcut to monitor or change the parameter values that you use most often. The default Home Page is shown on the following page. When a parameter normally located in the Setup Page or Operations Page is placed in the Home Page, it is accessible through both. If you change a parameter in the Home Page, it is automatically changed in its original page. If you change a parameter in its original page it is automatically changed in the Home Page.

Use the Advance Key  to step through the other parameters. When not in pairs, the parameter prompt will appear in the green display, and the parameter value will appear in the red display. You can use the Up  and Down  keys to change the value of writable parameters, just as you would in any other menu.

Note:

If a writable value is placed on the red display and is paired with another read only parameter on the green display, the arrow keys affect the setting of the red display. If two writable parameters are paired, the arrow keys affect the green display.

- The Attention *Attn* parameter appears only if there is an active message. An example of an active message could be a Input Error *Err!*, or it could be for information only like Autotune *Auto!* taking place.
- If Control Mode is set to Auto, the Process Value is in the red display and the Set Point (read-write) is in the green display.
- If a profile is running, the process value is in the red display and the Target Set Point (read only) is in the green display. If Control Mode is set to Manual, the Process Value is in the red display and Manual Power (read-write) is in the green display.
- If Control Mode is set to Off, the Process Value is in the red display and *OFF* (read only) is in the green display.
- If a sensor failure has occurred, dashes *---* will be displayed in the red display and the Manual Power (read-write) is in the green display.
- 0 to 100% activates the heat output and 0 to 100% activates the cooling output in manual mode.

Navigating the PM3 LEGACY™ PID Controller

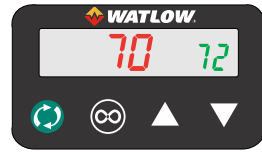
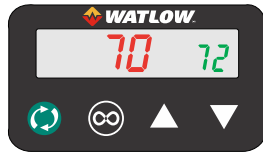
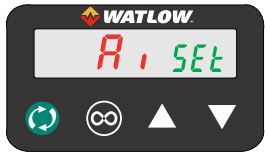

Home Page from anywhere: Press the Infinity Key  for two seconds to return to the Home page.

Factory Page from Home Page: Press both the Advance  and Infinity  keys for six seconds.

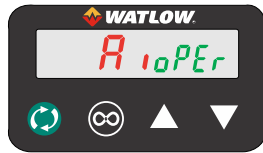
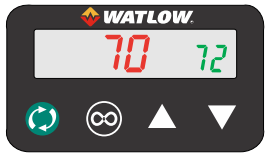

Operations Page from Home Page: Press both the Up  and Down  keys for three seconds.

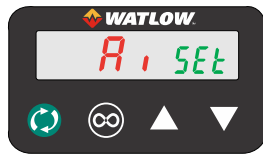
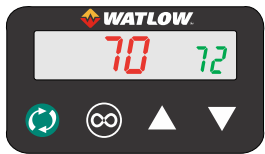

Note:

Keys must be held continuously until *SEt* is displayed in green. If keys are released when *oPEr* is displayed, press the infinity key or reset key to exit and repeat until *SEt* is displayed.

Setup Page from Home Page: Press both the Up  and Down  keys for six seconds.

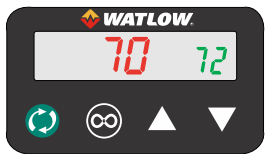







Profiling Page from Home Page: Press the Advance Key  for three seconds.





Changing the Set Point

You can change the set point by using the Up  or Down  keys when a profile is not running.







Starting a Profile from the Home Page

1. When at the Home Page, press the Advance Key  to locate Profile Start and select the file or step number to start. The display will show *!* and the green display will show *P.St I.*
2. Press the Up  or Down  key to choose the file number.
3. Press the Advance Key  to select the Profile Action Request. The red display will show *nonE* and the green display will show *P.AC I.*
4. Press the Up  or Down  keys to select the Profile Start. The red display will show *P_r_oF* and the green display will show *P.AC I.*
5. Press the Infinity  Key to return Home. The Profile will start.

Ending a Profile from the Home Page

1. Press the Advance Key  to select the Profile Action Request. The red display will show *nonE* and the green display will show *P.A.C I.*
2. Press the Up  or Down  keys to select the End. The red display will show *End* and the green display will show *P.A.C I.*
3. Press the Infinity  Key to return Home. The Profile will End.

Modifying the Home Page

1. Push and hold the Advance  key and the Infinity  key for approximately six seconds. Upon entering the Factory Page the first menu will be the Custom Menu *CUST.*
2. Push the Advance  key where the green display will show *CUST* and the red display will show *!*.
3. Push the Advance  button where the prompt for the Process Value *ACPU* will be displayed on top and Parameter *PAR* in the bottom. There are twenty positions available that can be customized.
4. Pushing the Up  or Down  arrow keys will allow for a customized selection to be made (see list of available parameters below).

Custom Menu Parameter Options	
Description	Prompt *
All Models	
None	Blank
Analog Input Value	<i>A in 1</i>
Cal In Offset	<i>.CAR 1</i>
Display Units	<i>C_F 1</i>
Load Parameter Set	<i>USr.1 USr.2</i>
Alarm Low Set Point	<i>ALo 1 ALo 2 ALo 3 ALo 4</i>
Alarm High Set Point	<i>Ah .1 Ah .2 Ah .3 Ah .4</i>
Alarm Hysteresis	<i>Ahy 1 Ahy 2 Ahy 3 Ahy 4</i>
If 4th digit of part number is T	
Time Remaining	<i>t.r</i>
Ready Band State	<i>r.bS</i>
Ready Band	<i>r.dY</i>
Closed Loop Timer Set Point	<i>CL.SP</i>
Hours	<i>hOUr</i>
Minutes	<i>Min</i>
Seconds	<i>SEC</i>
If 4th digit of part number is C, R, J, or N	
Set Point	<i>CL.SP 1</i>
Active Process Value	<i>AC.P 1</i>
Active Set Point	<i>AC.S 1</i>
Manual Power	<i>a.SP 1</i>

Custom Menu Parameter Options	
Description	Prompt *
Autotune	<i>AUT 1</i>
Control Mode	<i>CP 1</i>
Heat Power	<i>hPr 1</i>
Cool Power	<i>CP 1</i>
Time Integral	<i>t i 1</i>
Time Derivative	<i>t d 1</i>
Dead Band	<i>db 1</i>
Heat Prop Band	<i>hPb 1</i>
On/Off Heat Hysteresis	<i>hhY 1</i>
Cool Prop Band	<i>CPb 1</i>
On/Off Cool Hysteresis	<i>chY 1</i>
Ramp Rate	<i>r.r 1</i>
TRU-TUNE+ Enable	<i>t.tU 1</i>
Idle Set Point	<i>idS 1</i>
If 4th digit of part number is R or N	
Profile Start	<i>PSt 1</i>
Profile Action Request	<i>PAC 1</i>
Current Step	<i>StP</i>
Step Type	<i>StYP</i>
Target Set Point	<i>t.SP 1</i>
Produced Set Point	<i>ACSP</i>
Hour	<i>HoUr</i>
Minute	<i>Pr in</i>
Second	<i>SEC</i>
Guaranteed Soak Deviation 1	<i>gSd 1</i>
Active Event Output 1	<i>Ent 1</i>
Active Event Output 2	<i>Ent 2</i>

Modifying the Display Pairs

The Home Page, being a customized list of as many as 20 parameters, can be configured in pairs of up to 10 via the Display Pairs *dPr 5* prompt found in the Global Menu *gLBL* (Setup Page). The listing in the table that follows is what one may typically find in the Home Page as defaults based on controller part numbers. It is important to note that some of the prompts shown may not appear simply because the feature is not being used or is turned off. As an example, the prompt shown in position 7 (loop 1) and position 12 (loop 2) *CP* will not appear unless the Cool algorithm *CA9* is turned on in the Setup Page under the Loop menu.

As stated above, the user can define pairs of prompts to appear on the display every time the Advance  key is pushed. The first pair will always be as defined in the Custom Menu and as

stated, will default (factory settings) to the Active Process Value loop 1 *ACP_u*, and the Active Set Point loop 1 *ACSP*. If two channels are present the first 2 pairs will be the same in that the first pair will represent channel 1 Active Process Value and Active Set Point and the second being the same for channel 2. If another pair is created where the Display Pairs *dPr5* prompt is equal to 3 using the default prompts, when the Advance Key  is pushed two times from the Home Page the red display will reflect the current control mode and the green display would show the output power. When configuring the Custom Menu to your liking it should be noted that if a writable value is placed on the red display and is paired with another read only parameter on the green display, the arrow keys will affect the setting of the red display. Also, if 2 changeable (writable) prompts are displayed in a Pair, i.e., Control Mode on top and Idle Set Point on the bottom, only the green display (Idle Set Point) can be changed.

The display can be configured to scroll customized pairs by going to the Setup Page under the Global Menu and changing the Display Time *dt*, prompt to something greater than 0 and by changing the Display Pairs *dPr5* to something greater than 1. If the Display Time *dt* is set to 2, the display will toggle every 2 seconds from the first display pair to the second and then the third, etc... The display will continue to toggle through all of the custom pairs at the specified time interval.

When configuring the Custom Menu to your liking, it should be noted that if two writable prompts are displayed in a pair, for example, Control Mode on top and Idle Set Point on the bottom, only the green display (Idle Set Point) can be changed. If a writable value is placed on the red display and is paired with another read only parameter on the green display, the arrow keys affect the setting of the red display.

	Possible Home Page Defaults (Dependent on Part Number)	Home Page Display	Parameter Page and Menu
All Models			
1	Active Process Value (1)	Numerical value	Operations Page, Monitor Menu
If 4th digit of part number is equal to: PM3 [T] _ _ _ AAAN _ _			
2	Time Remaining (2)	Numerical value	Operations Page, Timer Menu
If 4th digit of part number is equal to: PM3 [C, R, J, N] _ _ _ AAAN _ _			
2	Active Set Point (1)	Numerical value	Operations Page, Monitor Menu
If 4th digit of part number is equal to: PM3 [T] _ _ _ AAAAN _ _			
3	Active Set Point (1)	Numerical value	Operations Page, Monitor Menu
	Possible Home Page Defaults (Dependent on Part Number)	Home Page Display	Parameter Page and Menu
If 4th digit of part number is equal to: PM3 [T] _ _ _ AAAN _ _			
4	Set Point (1)	Numerical value	Operations Page, Monitor Menu
5	Ready State Band (1)	<i>r.b5</i>	Operations Page, Timer Menu
6	Ready Band (1)	<i>rdy</i>	Operations Page, Timer Menu
7	Closed Loop Timer Set Point (1)	<i>[t.SP]</i>	Operations Page, Timer Menu
8	Hours (1)	<i>hour</i>	Operations Page, Timer Menu
9	Minutes (1)	<i>min</i>	Operations Page, Timer Menu

10	Seconds (2)	SEC	Operations Page, Timer Menu
If 4th digit of part number is equal to: PM3 [R, N] _ _ _ _ AAAN _ _			
3	Control Mode	C.P7 I	Operations Page, Monitor Menu
4	Heat Power	h.Pr I	Operations Page, Monitor Menu
5	Autotune	AUT I	Operations Page, Loop Menu
6	Idle Set Point	idS I	Operations Page, Loop Menu
7	Profile Start	P.St I	Operations Page, Profile Status
8	Action Request	P.AC I	Operations Page, Profile Status

Note:

The numerical digit shown in the prompts (last digit) and within the parenthesize above, represents the parameter instance and can be greater than one.

Conventions Used in the Menu Pages

To better understand the menu pages that follow review the naming conventions used. When encountered throughout this document, the word "default" implies as shipped from the factory. Each page (Operations, Setup, Profile and Factory) and their associated menus have identical headers defined below:

Header Name	Definition
Display	Visually displayed information from the control.
Parameter Name	Describes the function of the given parameter.
Range	Defines options available for this prompt, i.e., min/max values (numerical), yes/no, etc... (further explanation below).
Default	Values as delivered from the factory.
Modbus Relative Address	Identifies unique parameters using either the Modbus RTU or Modbus TCP protocols (further explanation below).
CIP (Common Industrial Protocol)	Identifies unique parameters using either the DeviceNet or EtherNet/IP protocol (further explanation below).
Profibus Index	Identifies unique parameters using Profibus DP protocol (further explanation below).
Parameter ID	Identifies unique parameters used with other software such as, LabVIEW.
Header Name	Definition
Data Type R/W	uint = Unsigned 16 bit integer dint = Signed 32-bit, long string = ASCII (8 bits per character) float = IEEE 754 32-bit RWES = Readable Writable EEPROM (saved) User Set (saved)

Display

Visual information from the control is displayed to the observer using a fairly standard 7 segment display. Due to the use of this technology, several characters displayed need some interpretation, see the list below:

1 = 1	7 = 7	c, C = c	i = i	o = o	u, U = u
2 = 2	8 = 8	d = d	J = J	P = P	u, U = v
3 = 3	9 = 9	E = E	H = K	q = q	LJ = W
4 = 4	0 = 0	F = F	L = L	r = r	y = y
5 = 5	A = A	g = g	∩∩ = M	S = S	2 = Z
6 = 6	b = b	h = h	n = n	t = t	

Range

Within this column notice that on occasion there will be numbers found within parenthesis. This number represents the enumerated value for that particular selection. Range selections can be made simply by writing the enumerated value of choice using any of the available communications protocols. As an example, turn to the Setup Page and look at the Analog Input A_i menu and then the Sensor Type SE_n prompt. To turn the sensor off using Modbus simply write the value of 62 (off) to register 368 and send that value to the control.

Modbus RTU Protocols

All Modbus registers are 16-bits and as displayed in this manual are relative addresses (actual). Some legacy software packages limit available Modbus registers to 40001 to 49999 (5 digits). Many applications today require access to all available Modbus registers which range from 400001 to 465535 (6 digits). Watlow controls support 6 digit Modbus registers. For parameters listed as float notice that only one (low order) of the two registers is listed, this is true throughout this document. By default the low order word contains the two low bytes of the 32-bit parameter. As an example, look in the Operations Page for the Process Value. Find the column identified in the header as Modbus and notice that it lists register 360. Because this parameter is a float it is actually represented by registers 360 (low order bytes) and 361 (high order bytes). Because the Modbus specification does not dictate which register should be high or low order, Watlow provides the user the ability to swap this order (Setup Page, $COPT$ Menu) from the default low/high $LoHi$ to high/low $HiLo$.

Note:

With the release of firmware revision 7.00 and above new functions were introduced into this product line. With the introduction of these new functions there was a reorganization of Modbus registers. Notice in the column identified as Modbus the reference to Map 1 and Map 2 registers for each of the various parameters. If the new functions, namely; Linearization, Process Value and Real Time Clock are to be used than use Map 2 Modbus registers. The Data Map $OPTAP$ for Modbus registers can be changed in the Setup Page under the $COPT$ Menu. This setting will apply across the control.

It should also be noted that some of the cells in the Modbus column contain wording pertaining to an offset. Several parameters in the control contain more than one instance; such as, profiles (4), alarms (4), analog inputs (2), etc.. The Modbus register shown always represents instance one. Take for an example the Alarm Silence parameter found in the Setup Page under the Alarm menu. Instance one of Map 1 is shown as address 1490 and +50 is identified as the offset to the next instance. If there was a desire to read or write to instance 3 simply add 100 to 1490 to find its address, in this case, the instance 3 address for Alarm Silence is 1590.

To learn more about the Modbus protocol point your browser to <http://www.modbus.org>.

Note:

There are two columns shown in the menus that follow for communications protocols identified as CIP (Common Industrial Protocol) and Profibus. These columns will be useful if this control is used in conjunction with the PM3 LEGACY™ PID Remote User Interface/Gateway (RUI/GTW) where those protocols can be selected as optional hardware. For this control, as a secondary protocol beyond Standard Bus, Modbus RTU can be ordered as optional hardware.

To learn more about the RUI/GTW point your browser to the link below and search for keyword gateway.

<http://www.watlow.com/en/Resources-And-Support/Technical-Library/User-Manuals>

5

Chapter 5: Operations Page

PM Operation Page Parameters

To navigate to the Operations Page, follow the steps below:

1. From the Home Page, press both the Up ▲ and Down ▼ keys for three seconds. *A i* will appear in the red display and *oPEr* will appear in the green display.
2. Press the Up ▲ or Down ▼ key to view available menus.
3. Press the Advance Key ⏩ to enter the menu of choice.
4. If a submenu exists (more than one instance), press the Up ▲ or Down ▼ key to select and then press the Advance Key ⏩ to enter.
5. Press the Up ▲ or Down ▼ key to move through available menu prompts.
6. Press the Infinity Key ∞ to move backwards through the levels: parameter to submenu, submenu to menu, menu to Home Page.
7. Press and hold the Infinity Key ∞ for two seconds to return to the Home Page.

On the following pages, top level menus are identified with a yellow background color.

Note:

Some of these menus and parameters may not appear, depending on the controller's options. See model number information in the Appendix for more information. If there is only one instance of a menu, no submenus will appear.

Note:

Some of the listed parameters may not be visible. Parameter visibility is dependent upon controller part number.

A i

oPEr Analog Input Menu

- A i n* Analog Input Value
- iEr* Input Error
- iCA* Calibration Offset

L n r

oPEr Linearization Menu

- S u A* Source Value A
- oFSt* Offset
- o v* Output Value

P u

oPEr Process Value Menu

- S u A* Source Value A
- oFSt* Offset
- o v* Output Value

d i o

oPEr Digital Input/Output Menu

- 5*
- d i o* Digital Input/Output (5 to 6)
- d o S* Output State
- d i S* Input State
- E i S* Event Status

M o n

oPEr Monitor Menu

- C n t r l* Control Mode Active
- h P r* Heat Power
- C P r* Cool Power
- C L S P* Closed-Loop Set Point
- P u A* Process Value Active

Loop

oPEr Loop Menu

<i>C.M</i>	Control Mode
<i>AtSP</i>	Autotune Set Point
<i>AUT</i>	Autotune
<i>CSP</i>	Closed Loop Set Point
<i>IdS</i>	Idle Set Point
<i>hPb</i>	Heat Proportional Band
<i>hHy</i>	On/Off Heat Hysteresis
<i>CPb</i>	Cool Proportional Band
<i>CHy</i>	On/Off Cool Hysteresis
<i>tI</i>	Time Integral
<i>tD</i>	Time Derivative
<i>db</i>	Dead Band
<i>oSP</i>	Manual Power

ALPn

oPEr Alarm Menu

1

<i>ALPn</i>	Alarm (1 to 4)
<i>ALo</i>	Low Set Point
<i>AHi</i>	High Set Point
<i>ACLr</i>	Clear Alarm
<i>ASir</i>	Silence Alarm
<i>ASt</i>	Alarm State

tPn

oPEr Timer Menu

<i>SuA</i>	Source Value A
<i>SuC</i>	Source Value C
<i>SuD</i>	Source Value D
<i>PSP1</i>	Produced Set Point 1
<i>tEo1</i>	Timer Event Output 1
<i>tEo2</i>	Timer Event Output 2
<i>tEo3</i>	Timer Event Output 3
<i>tR</i>	Time Remaining
<i>r.bS</i>	Ready Band State
<i>hOUr</i>	Hours
<i>Pn in</i>	Minutes
<i>SEC</i>	Seconds
<i>CtSP</i>	Closed Loop Timer Set Point

PStA

oPEr Profile Status Menu

<i>PStR</i>	Profile Start
<i>PACr</i>	Profile Action Request
<i>StP</i>	Current Step
<i>StYP</i>	Step Type
<i>tSP1</i>	Target Set Point Loop 1
<i>ACSP</i>	Produced Set Point 1
<i>hOUr</i>	Hours Remaining
<i>Pn in</i>	Minutes Remaining
<i>SEC</i>	Seconds Remaining
<i>Ent1</i>	Active Event Output 1
<i>Ent2</i>	Active Event Output 2
<i>JC</i>	Jump Count Remaining

Operations Page

Display	Parameter Name Description	Range	Default	Modbus Relative Address	Parameter ID	Data Type and Access **
A i oPEr Analog Input Menu						
A i Ain	Analog Input Analog Input Value View the process value. Note: Ensure that the Input Error (below) indicates no error (61) when reading this value using a field bus protocol. If an error exists, the last known value prior to the error occurring will be returned.	-1,999.000 to 9,999.000°F or units -1,128.000 to 5,537.000°C	- - - -	Instance 1 Map 1 Map 2 360 360	4001	float R
i.Er i.Er	Analog Input Input Error View the cause of the most recent error. If the AttEn message is Er.i1 or Er.i2 , this parameter will display the cause of the input error.	nonE None (61) oPEn Open (65) Shrt Shorted (127) EPn Measurement Error (140) E.CAL Bad Calibration Data (139) Er.Ab Ambient Error (9) Er.td RTD Error (141) FR.iL Fail (32) NSrc Not Sourced (246)	- - - -	Instance 1 Map 1 Map 2 362 362	4002	uint R
i.CA i.CA	Analog Input Calibration Offset Offset the input reading to compensate for lead wire resistance or other factors that cause the input reading to vary from the actual process value.	-1,999.000 to 9,999.000°F or units -1,110.555 to 5,555.000°C	0.0	Instance 1 Map 1 Map 2 382 382	4012	float RWES
** R: Read, W: Write, E: EEPROM, S: User Set						

Operations Page

Display	Parameter Name Description	Range	Default	Modbus Relative Address	Parameter ID	Data Type and Access **
<p><i>Lnr</i> <i>oPEr</i> Linearization Menu</p>						
<i>SuA</i> Su.A	Linearization Source Value A View the value of Source A. Source A of Linearization 1 is connected to Analog Input 1, Source A of Linearization 2 is connected to Analog Input 2	-1,999.000 to 9,999.000°F or units -1,128.000 to 5,537.000°C	----	<i>Instance 1</i> Map 1Map 2 ---- 3566	34004	float R
<i>oFSt</i> oFSt	Linearization Offset Set an offset to be applied to this function's output.	-1,999.000 to 9,999.000°F or units -1,128.000 to 5,537.000°C	0	<i>Instance 1</i> Map 1Map 2 ---- 3570	34006	float RWES
<i>o.v</i> o.v	Linearization Output Value View the value of this function's output.	-1,999.000 to 9,999.000°F or units -1,128.000 to 5,537.000°C	----	<i>Instance 1</i> Map 1Map 2 ---- 3572	34007	float R
No Display	Linearization Error View reported cause for Linearization output malfunction.	None (61) Open (65) Shorted (127) Measurement error (140) Bad calibration data (139) Ambient error (9) RTD error (14) Fail (32) Math error (1423) Not sourced (246) Stale (1617) Can't process (1659)	----	<i>Instance 1</i> Map 1Map 2 ---- 3614	34028	uint R
** R: Read, W: Write, E: EEPROM, S: User Set						

Operations Page

Display	Parameter Name Description	Range	Default	Modbus Relative Address	Parameter ID	Data Type and Access **
Pu oPEr Process Value Menu						
Su.A Su.A	Process Value Source Value A View the value of Source A. Linearization 1 is connected to Source A of Process Value 1.	-1,999.000 to 9,999.000°F or units -1,128.000 to 5,537.000°C	- - - -	Instance 1 Map 1 Map 2 - - - - 3310	26016	float R
oFSt oFSt	Process Value Offset Set an offset to be applied to this function's output.	-1,999.000 to 9,999.000°F or units -1,128.000 to 5,537.000°C	0	Instance 1 Map 1 Map 2 - - - - 3324	26023	float RWES
o.u o.u	Process Value Output Value View the value of this function block's output.	-1,999.000 to 9,999.000°F or units -1,128.000 to 5,537.000°C	- - - -	Instance 1 Map 1 Map 2 - - - - 3322	26022	float R
No Display	Process Value Output Error View reported cause for Process output malfunction.	None (61) Open (65) Shorted (127) Measurement error (140) Bad calibration data (139) Ambient error (9) RTD error (14) Fail (32) Math error (1423) Not sourced (246) Stale (1617) Can't process (1659)	- - - -	Instance 1 Map 1 Map 2 - - - - 3332	26027	uint R
dIo oPEr Digital Input/Output Menu						
do.S do.S	Digital Output (5 to 6) Output State View the state of this output.	oFF Off (62) oN On (63)	- - - -	Instance 5 Map 1 Map 2 1012 1132 Offset to next instance equals +30	6007	uint R
** R: Read, W: Write, E: EEPROM, S: User Set						

Operations Page

Display	Parameter Name Description	Range	Default	Modbus Relative Address	Parameter ID	Data Type and Access **
d i.S di.S	Digital Input (5 to 6) Input State View this event input state.	oFF Off (62) oN On (63)	----	Instance 5 Map 1 Map 2 1020 1140 Offset to next instance equals +30	6011	uint R
E i.S Ei.S	Digital Input (5 to 6) Event Status View this event input state.	i nA ct Inactive (41) A ct Active (5)	----	Instance 5 Map 1 Map 2 1408 1648 Offset to next instance equals +20	10005	uint R
MAN OPER Monitor Menu						
C.P.A C.MA	Monitor Control Mode Active View the current control mode.	oFF Off (62) A U t o Auto (10) M A N Manual (54)	----	Instance 1 Map 1 Map 2 1882 2362	8002	uint R
h.Pr h.Pr	Monitor Heat Power View the current heat output level.	0.0 to 100.0%	----	Instance 1 Map 1 Map 2 1904 2384	8011	float R
C.Pr C.Pr	Monitor Cool Power View the current cool output level.	-100.0 to 0.0%	----	Instance 1 Map 1 Map 2 1906 2386	8014	float R
C.SP C.SP	Monitor Closed-Loop Set Point View the working set point currently in effect.	-1,999.000 to 9,999.000°F or units -1,128.000 to 5,537.000°C	----	----	8029	float R
P.v.A Pv.A	Monitor Process Value Active View the current filtered process value using the control input.	-1,999.000 to 9,999.000°F or units -1,128.000 to 5,537.000°C	----	Instance 1 Map 1 Map 2 402 402	8031	float R
No Display	Monitor Set Point Active Read the current active set point.	-1,999.000 to 9,999.000°F or units -1,128.000 to 5,537.000°C	----	Instance 1 Map 1 Map 2 2172 2652	8031	float R
** R: Read, W: Write, E: EEPROM, S: User Set						

Operations Page

Display	Parameter Name Description	Range	Default	Modbus Relative Address	Parameter ID	Data Type and Access **
No Display	Monitor Autotune Status Read the present status of Autotune.	Off (62) Waiting for cross 1 positive (119) Waiting for cross 1 negative (120) Waiting for cross 2 positive (121) Waiting for cross 2 negative (122) Waiting for cross 3 positive (123) Waiting for cross 3 negative (150) Measuring maximum peak (151) Measuring minimum peak (152) Calculating (153) Complete (18) Timeout (118)	- - - -	Instance 1 Map 1 Map 2 1932 2412	8027	uint R
<p>LoOP oPEr Control Loop Menu</p>						
C.M	Control Loop (1 to 2) Control Mode Select the method that this loop will use to control.	oFF Off (62) AUto Auto (10) MAN Manual (54)	Auto	Instance 1 Map 1Map 2 1880 2360	8001	uint RWES
A.tSP	Control Loop Autotune Set Point Set the set point that the autotune will use, as a percentage of the current set point.	50.0 to 200.0%	90.0	Instance 1 Map 1Map 2 1918 2398	8025	float RWES
AUt	Control Loop Autotune Start an autotune. While the autotune is active, the Home Page will display Auton Tun! . When the autotune is complete, the message will clear automatically.	no No (59) YES Yes (106)	No	Instance 1 Map 1Map 2 1920 2400	8026	uint RW
C.SP	Control Loop Set Point Set the closed loop set point that the controller will automatically control to.	Low Set Point to Maximum Set Point (Setup Page)	75.0°F or units 24.0°C	Instance 1 Map 1Map 2 2160 2640	7001	float RWES
** R: Read, W: Write, E: EEPROM, S: User Set						

Operations Page

Display	Parameter Name Description	Range	Default	Modbus Relative Address	Parameter ID	Data Type and Access **
id.S id.S	Control Loop Idle Set Point Define a set point that can be triggered by an event state.	Low Set Point to High Set Point (Setup Page)	75.0°F or units 24.0°C	Instance 1 Map 1Map 2 2176 2656	7009	float RWES
h.Pb h.Pb	Control Loop Heat Proportional Band Set the PID proportional band for the heat outputs.	0.001 to 9,999.000°F or units 0.001 to 5,555.000°C	25.0°F or units 14.0°C	Instance 1 Map 1Map 2 1890 2370	8009	float RWES
h.hy h.hy	Control Loop On/Off Heat Hysteresis Set the control switching hysteresis for on-off control. This determines how far into the “on” region the process value needs to move before the output turns on.	0.001 to 9,999.000°F or units 0.001 to 5,555.000°C	3.0°F or units 2.0°C	Instance 1 Map 1Map 2 1900 2380	8010	float RWES
C.Pb C.Pb	Control Loop Cool Proportional Band Set the PID proportional band for the cool outputs.	0.001 to 9,999.000°F or units 0.001 to 5,555.000°C	25.0°F or units 14.0°C	Instance 1 Map 1Map 2 1892 2372	8012	float RWES
C.hy C.hy	Control Loop On/Off Cool Hysteresis Set the control switching hysteresis for on-off control. This determines how far into the “on” region the process value needs to move before the output turns on.	0.001 to 9,999.000°F or units 0.001 to 5,555.000°C	3.0°F or units 2.0°C	Instance 1 Map 1Map 2 1902 2382	8013	float RWES
ti ti	Control Loop Time Integral Set the PID integral for the outputs.	0 to 9,999 seconds per repeat	180 seconds per repeat	Instance 1 Map 1Map 2 1894 2374	8006	float RWES
td td	Control Loop Time Derivative Set the PID derivative time for the outputs.	0 to 9,999 seconds	0 seconds	Instance 1 Map 1Map 2 1896 2376	8007	float RWES

** R: Read, W: Write, E: EEPROM, S: User Set

Operations Page

Display	Parameter Name Description	Range	Default	Modbus Relative Address	Parameter ID	Data Type and Access **
db db	Control Loop Dead Band Set the offset to the proportional band. With a negative value, both heating and cooling outputs are active when the process value is near the set point. A positive value keeps heating and cooling outputs from fighting each other.	-1,000.0 to 1,000.0°F or units -556 to 556°C	0.0	Instance 1 Map 1 Map 2 1898 2378	8008	float RWES
o.SP o.SP	Control Loop Manual Power Set a fixed level of output power when in manual (open-loop) mode.	-100 to 100% (heat and cool) 0 to 100% (heat only) -100 to 0% (cool only)	0.0	Instance 1 Map 1 Map 2 2162 2642	7002	float RWES
No Display	Control Loop Loop Error Open Loop detect deviation has been exceeded.	None (61) Open Loop (1274) Reversed Sensor (1275)	- - - -	Instance 1 Map 1 Map 2 1928 2408	8048	uint R
No Display	Control Loop Clear Loop Error Current state of limit output.	Clear (129) Ignore (204)	- - - -	Instance 1 Map 1 Map 2 1930 2410	8049	uint W
No Display	Control Loop Loop Output Power View the loop output power.	-100.0 to 100.0	- - - -	Instance 1 Map 1 Map 2 1908 2388	8033	float R
** R: Read, W: Write, E: EEPROM, S: User Set						

Operations Page

Display	Parameter Name Description	Range	Default	Modbus Relative Address	Parameter ID	Data Type and Access **
<div style="color: red; font-weight: bold; font-size: 1.2em;">AL??</div> <div style="color: green; font-weight: bold; font-size: 1.2em;">oPEr</div> Alarm Menu						
<div style="color: green; font-weight: bold;">ALo</div> A.Lo	Alarm (1 to 4) Low Set Point If Type (Setup Page, Alarm Menu) is set to: Process - set the process value that will trigger a low alarm. Deviation - set the span of units from the set point that will trigger a low alarm. A negative set point represents a value below closed loop set point. A positive set point represents a value above closed loop set point.	-1,999.000 to 9,999.000°F or units -1,128.000 to 5,537.000°C	32.0°F or units 0.0°C	Instance 1 Map 1Map 2 1482 1882 Offset to next instance (Map 1) equals +50 Offset to next instance (Map 2) equals +60	9002	float RWES
<div style="color: green; font-weight: bold;">Ahi</div> A.hi	Alarm (1 to 4) High Set Point If Type (Setup Page, Alarm Menu) is set to: Process - set the process value that will trigger a high alarm. Deviation - set the span of units from the set point that will trigger a low alarm. A negative set point represents a value below closed loop set point. A positive set point represents a value above closed loop set point.	-1,999.000 to 9,999.000°F or units -1,128.000 to 5,537.000°C	300.0 °F or units 150.0 °C	Instance 1 Map 1Map 2 1480 1880 Offset to next instance (Map 1) equals +50 Offset to next instance (Map 2) equals +60	9001	float RWES
<div style="color: green; font-weight: bold;">ALr</div> A.Clr	Alarm (1 to 4) Clear Alarm Write to this register to clear an alarm	<div style="color: red; font-weight: bold;">ELr</div> Clear (1003) <div style="color: red; font-weight: bold;">,Ignr</div> Ignore (204)	-----	Instance 1 Map 1Map 2 1504 1904 Offset to next instance (Map1 1) equals +50, Map 2 equals +60)	9026	uint W
** R: Read, W: Write, E: EEPROM, S: User Set						

Operations Page

Display	Parameter Name Description	Range	Default	Modbus Relative Address	Parameter ID	Data Type and Access **
ASir A.Sir	Alarm (1 to 4) Silence Alarm Write to this register to silence an alarm	Sil Silence (1010)		Instance 1 Map 1Map 2 1506 1906 Offset to next instance (Map1 1 equals +50, Map 2 equals +60)	9027	uint W
ASSt A.St	Alarm (1 to 4) State Current state of alarm	Startup (88) None (61) Blocked (12) Alarm low (8) Alarm high (7) Error (28)	----	Instance 1 Map 1Map 2 1496 1896 Offset to next instance (Map1 1 equals +50, Map 2 equals +60)	9009	uint R
No Dis- play	Alarm (1 to 4) Alarm Clearable Indicates if alarm can be cleared.	No (59) Yes (106)	----	Instance 1 Map 1Map 2 1502 1902 Offset to next instance (Map1 1 equals +50, Map 2 equals +60)	9012	uint R
No Dis- play	Alarm (1 to 4) Alarm Silenced Indicates if alarm is silenced.	No (59) Yes (106)	----	Instance 1 Map 1Map 2 1500 1900 Offset to next instance (Map1 1 equals +50, Map 2 equals +60)	9011	uint R
No Dis- play	Alarm (1 to 4) Alarm Latched Indicates if alarm is latched.	No (59) Yes (106)	----	Instance 1 Map 1Map 2 1498 1898 Offset to next instance (Map1 1 equals +50, Map 2 equals +60)	9010	uint R

OPER

Timer Menu

SuA Su.A	Timer Source Value A View the state of Source Function A.	On On (63) Off Off (62)	----	Instance 1 Map 1Map 2 4582 8012	31007	uint R
SuC Su.C	Timer (1) Source Value C View the value of Source Function C.	-1999.000 to 999.000°F or units -1110.555 to 5555.000	----	Instance 1 Map 1Map 2 4642 8572	31037	float R

** R: Read, W: Write, E: EEPROM, S: User Set

Operations Page

Display	Parameter Name Description	Range	Default	Modbus Relative Address	Parameter ID	Data Type and Access **
Su.d Su.d	Timer (1) Source Value D View the state of Source Function D.	On (63) Off (62)	----	Instance 1 Map 1Map 2 4644 8574	31038	uint R
P.SP 1 P.SP1	Timer (1) Produced Set Point 1 View the value of Set Point 1.	-1999.000 to 999.000°F or units -1110.555 to 5555.000	----	Instance 1 Map 1Map 2 4646 8576	31039	float R
tE.o 1 tE.o1	Timer (1) Timer Event Output 1 View the state of Event Output 1.	On (63) Off (62)	----	Instance 1 Map 1Map 2 4648 8578	31040	uint R
tE.o 2 tE.o2	Timer (1) Timer Event Output 2 View the state of Event Output 2.	On (63) Off (62)	----	Instance 1 Map 1Map 2 4650 8580	31041	uint R
tE.o 3 tE.o3	Timer (1) Timer Event Output 3 View the state of Event Output 3.	On (63) Off (62)	----	Instance 1 Map 1Map 2 4662 8590	31046	uint R
t.r t.r	Timer Time Remaining Display the time remaining on the timer.	00:00 00:00 to 99:59	7	Instance 1 Map 1 Map 2 -----	31021	string R
r.bS r.bS	Timer Ready Band State Display whether the process value is in the ready band.	YES Yes (106) NO No (59)	----	Instance 1 Map 1 Map 2 4612 8542	31022	uint R
hoUr hoUr	Timer Hours Set the timer period hours.	0 to 99	0	Instance 1 Map 1 Map 2 4618 8548	31025	uint RWES
Min Min	Timer Minutes Set the timer period minutes.	0 to 59	0	Instance 1 Map 1 Map 2 4620 8550	31026	uint RWES
SEC SEC	Timer Seconds Set the timer period seconds.	0 to 59	10	Instance 1 Map 1 Map 2 4622 8552	31027	uint RWES
Ct.SP Ct.SP	Timer Closed Loop Timer Set Point Set the set point that will be in effect during the timer period.	-1999.000 to 9999.000°F or units -1110.555 to 5555.000°C	75	Instance 1 Map 1 Map 2 4624 8554	31028	float RWES

** R: Read, W: Write, E: EEPROM, S: User Set

Operations Page

Display	Parameter Name Description	Range	Default	Modbus Relative Address	Parameter ID	Data Type and Access **
No Display	Timer Timer Timing Indicates whether the timer is running.	On (63) Off (62)	----	Instance 1 Map 1 Map 2 4598 8528	31015	uint R
No Display	Timer Output Error Indicates errors that may have interfered with the timer operation.	None (61) Open (65) Shorted (127) Measurement Error (140) Bad Calibration Data (139) Ambient Error (9) RTD Error (141) Fail (32) Math Error (1423) Not Sourced (246) Stale (1617)	----	Instance 1 Map 1 Map 2 4604 8534	31018	uint R
No Display	Timer Indicator Request View the status of the timer illuminated indicators.	Off (62) Ready (1662) Ready Ack (1950) Running (149)	----	Instance 1 Map 1 Map 2 4652 8582	31042	uint R
No Display	Timer Countdown State View the state of the countdown cycle.	Inactive (41) Wait Process (209) Wait Event (144) Running (149) Pause (146) Complete (18) End (27)	----	Instance 1 Map 1 Map 2 4654 8584	31043	uint R
No Display	Timer Elapsed Signal Time Counts from 0 to Signal Time while signal time is active.	0 to 4,294,967,295 mS	----	Instance 1 Map 1 Map 2 4662 8592	31047	udint R
No Display	Timer Elapsed Time Counts from 0 to Countdown Time while time cycle is active.	0 to 4,294,967,295 mS	----	Instance 1 Map 1 Map 2 4664 8594	31048	udint R

** R: Read, W: Write, E: EEPROM, S: User Set

Operations Page

Display	Parameter Name Description	Range	Default	Modbus Relative Address	Parameter ID	Data Type and Access **
P.STR OPER Profile Status Menu		* Some parameters in the Profile Status Menu can be changed for the currently running profile, but should only be changed by knowledgeable personnel and with caution. Changing parameters via the Profile Status Menu will not change the stored profile but will have an immediate impact on the profile that is running. Changes made to profile parameters in the Profiling Pages will be saved and will also have an immediate impact on the running profile.				
P.STR P.Str	Profile Status Profile Start	1 to 40	1	Instance 1 Map 1Map 2 2520 4340	22001	uint W
P.ACR PACr	Profile Status Action Request	none None (61) STEP Step (89) End Terminate (148) RESU Resume (147) PAUS Pause (146) PROF Profile (77)	None	Instance 1 Map 1Map 2 2540 4360	22011	uint W
STEP StP	Profile Status Current Step View the currently running step.	1 to 40 0 (none)	- - - -	Instance 1 Map 1Map 2 2526 4346	22004	uint R
STEP S.typ	Profile Status Step Type View the currently running step type.	UNUSED Unused Step (50) SOAK Soak (87) WTE Wait For Event (144) WTPR Wait For Process (209) WTBO Wait For Process or Event (210) JL Jump (116) End End (27) ET Time (143) RATE Ramp Rate (81)	- - - -	Instance 1 Map 1Map 2 2544 4364	22013	uint R
TEMP t.SP1	Profile Status Target Set Point Loop 1 View or change the target set point of the current step.	-1,999.000 to 9,999.000°F or units -1,128.000 to 5,537.000°C	0.0°F or units -18.0°C	Instance 1 Map 1Map 2 2542 4362	22012	float RW
ACSP AC.SP	Profile Status Produced Set Point 1 Display the current set point, even if the profile is ramping.	-1,999.000 to 9,999.000°F or units -1,128.000 to 5,537.000°C	- - - -	Instance 1 Map 1Map 2 2528 4348	22005	float R
** R: Read, W: Write, E: EEPROM, S: User Set						

Operations Page

Display	Parameter Name Description	Range	Default	Modbus Relative Address	Parameter ID	Data Type and Access **
hoUr hoUr	Profile Status Hours Step time remaining in hours.	0 to 9999	0	Instance 1 Map 1Map 2 - - - - 4494	22078	uint RW
Min Min	Profile Status Minutes Step time remaining in minutes.	0 to 59	0	Instance 1 Map 1Map 2 - - - - 4492	22077	uint RW
SEC SEC	Profile Status Seconds Step time remaining in seconds.	0 to 59	0	Instance 1 Map 1Map 2 - - - - 4490	22076	uint RW
Ent 1 Ent1	Profile Status *Event 1 View or change the event output states.	oFF Off (62) oN On (63)	Off	Instance 1 Map 1Map 2 2546 4366	22014	uint RW
Ent 2 Ent2	Profile Status *Event 2 View or change the event output states.	oFF Off (62) oN On (63)	Off	Instance 1 Map 1Map 2 2548 4368	22015	uint RW
JC JC	Profile Status Jump Count Remaining View the jump counts remaining for the current loop. In a profile with nested loops, this may not indicate the actual jump counts remaining.	0 to 9,999	- - - -	Instance 1 Map 1Map 2 2538 4358	22010	uint R
No Display	Profile Status Profile State Read current Profile state.	Off (62) Running (149) Pause (146)	- - - -	Instance 1 Map 1Map 2 2524 4344	22002	uint R
No Display	Profile Status Current File Indicates current file being executed.	1 to 25 0 (none)	- - - -	Instance 1 Map 1Map 2 2522 4342	22003	uint R













** R: Read, W: Write, E: EEPROM, S: User Set

6

Chapter 6: Setup Page

Navigating the Setup Page

To navigate to the Setup Page follow the steps below:

1. From the Home Page, press and hold both the Up  and Down  keys for six seconds. *A i* will appear in the red display and *SEt* will appear in the green display. If the up and down arrow keys are released where *oPEr* is displayed, simply press and hold those same keys for an additional 3 seconds.
2. Press the Up  or Down  key to view available menus.
3. Press the Advance Key  to enter the menu of choice.
4. If a submenu exists (more than one instance), press the Up  or Down  key to select and then press the Advance Key  to enter.
5. Press the Up  or Down  key to move through available menu prompts.
6. Press the Infinity Key  to move backwards through the levels: parameter to submenu, submenu to menu, menu to Home Page.
7. Press and hold the Infinity Key  for two seconds to return to the Home Page.

On the following pages, top level menus are identified with a yellow background color.

Note:

Some of these menus and parameters may not appear, depending on the controller's options. See model number information in the Appendix for more information. If there is only one instance of a menu, no submenus will appear.

Note:

Some of the listed parameters may not be visible. Parameter visibility is dependent upon controller part number.

A i

SEt Analog Input Menu

- SEn* Sensor Type
- L in* TC Linearization
- r tL* RTD Leads
- Un it* Units
- SLo* Scale Low
- Sh i* Scale High
- rLo* Range Low
- rhi* Range High
- PEE* Process Error Enable

PEL Process Error Low Value

- tC* Thermistor Curve
- r.r* Resistance Range
- F iL* Filter
- iEr* Input Error Latching
- dEE* Display Precision
- iEA* Calibration Offset *
- A in* Analog Input Value *
- iEr* Input Error *

Lnr

SEt Linearization Menu

- F n* Function
- SFnA* Source Function A
- S iA* Source Instance A
- Un it* Units
- iP.1* Input Point 1
- oP.1* Output Point 1
- iP.2* Input Point 2
- oP.2* Output Point 2
- iP.3* Input Point 3
- oP.3* Output Point 3

i.P.4 Input Point 4
o.P.4 Output Point 4
i.P.5 Input Point 5
o.P.5 Output Point 5
i.P.6 Input Point 6
o.P.6 Output Point 6
i.P.7 Input Point 7
o.P.7 Output Point 7
i.P.8 Input Point 8
o.P.8 Output Point 8
i.P.9 Input Point 9
o.P.9 Output Point 9
i.P.10 Input Point 10
o.P.10 Output Point 10

Pu

SEt Process Value

Fn Function
P.unk Pressure Units
A.unk Altitude Units
b.Pr Barometric Pressure
F.iL Filter

d io

SEt Digital Input/Output Menu

S

d io Digital Input/Output (5 to 6)
d.ir Direction
Fn Function
F.i Output Function Instance
a.Ct Time Base Type
a.tb Fixed Time Base
a.Lo Low Power Scale
a.h.i High Power Scale
LEu Active Level
Fn Action Function
F.i Function Instance

LoOP

SEt Control Loop Menu

h.A9 Heat Algorithm
C.A9 Cool Algorithm
C.Cr Cool Output Curve
h.Pb Heat Proportional Band *
h.hY On/Off Heat Hysteresis *
C.Pb Cool Proportional Band *
C.hY On/Off Cool Hysteresis *
t.i Time Integral *
t.d Time Derivative *
db Dead Band *
t.tUn TRU-TUNE+® Enable
t.band TRU-TUNE+ Band
t.gn TRU-TUNE+ Gain
A.tSP Autotune Set Point *
t.A9r Autotune Aggressiveness
P.dL Peltier Delay
U.FA Auto-to-Manual Power
F.A.iL Input Error Power
P.7A.n Fixed Power
L.dE Open Loop Detect Enable
L.d.t Open Loop Detect Time
L.d.d Open Loop Detect Deviation
r.P Ramp Action
r.S.C Ramp Scale
r.r.t Ramp Rate
L.SP Minimum Set Point
h.SP Maximum Set Point
C.SP Set Point*
i.d.S Idle Set Point *
S.P.L.o Minimum Manual Power
S.P.h.i Maximum Manual

Power

a.SP Manual Power *
C.P.7 Control Mode *

o.t.P.t

SEt Output Menu

i
o.t.P.t Output Digital (1 to 2)
F.n Function
F.i Function
a.Ct Time Base Type
a.tb Fixed Time Base
a.Lo Low Power Scale
a.h.i High Power Scale
o.t.P.t Output Process 1
a.t.Y Type
F.n Function
r.S.r Retransmit Source
F.i Output Function Instance
S.Lo Scale Low
S.h.i Scale High
r.Lo Range Low
r.h.i Range High
a.C.A Calibration Offset

ALP.7

SEt Alarm Menu

i
ALP.7 Alarm (1 to 4)
A.t.Y Type
S.r.A Alarm Source
A.h.Y Hysteresis
AL.9 Logic
A.S.d Sides
AL.o Low Set Point *
A.h.i High Set Point *
AL.A Latching
A.b.L Blocking
A.S.i Silencing
A.d.SP Display
A.d.L Delay Time
A.C.L.r Clear Alarm *

AS_r Silence Alarm *

AS_t Alarm State *

CP_r

SEt **Timer Menu**

t.En Timer Enable

t.st Timer Start Method

SFnA Source Function A

S.iA Source Instance A

SFnC Source Function C

S.iC Source Instance C

SFnD Source Function D

S.iD Source Instance D

t.r Time Remaining

r.bS Ready Band State

r.dy Ready Band

t.For Time Format

hoUr Hours

Min Minutes

SEC Seconds

CLSP Closed Loop Timer
Set Point

St Signal Time

GLbL

SEt **Global Menu**

CLF Display Units

ACLF AC Line Frequency

r.tYP Ramping Type

P.tYP Profile Type

gSE Guaranteed Soak
Enable

gSD1 Guaranteed Soak
Deviation 1

S.iA Source Instance A

S.iB Source Instance B

POt_i Power Off Time

SuTb Synchronized Vari-
able Time Base

CLEd Communications
LED Action

Zone Zone

ChAn Channel

dPrS Display Pairs

dt_i Display Time

USr.S Save Settings As

USr.r Restore Settings
From

bTtH Bluetooth

CP_r

SEt **Communications Menu**

PCoL Protocol

AdS Standard Bus Ad-
dress

AdP_r Modbus Address

BAUd Baud Rate

PAR Parity

P_rhL Modbus Word Order

CLF Display Units

P_rAP Data Map

nUS Non-volatile Save

Setup Page

Parameter Name Description	Range	Default	Modbus Relative Address	Parameter ID	Data Type and Access **
<p><i>Al</i> <i>SEt</i></p> <p>Analog Input Menu</p>					
<p>Analog Input Sensor Type Set the analog sensor type to match the device wired to this input.</p> <p>Note: There is no open sensor protection for process inputs.</p>	<p><i>oFF</i> Off (62)</p> <p><i>tC</i> Thermocouple (95)</p> <p><i>mV</i> Millivolts (56)</p> <p><i>volt</i> Volts dc (104)</p> <p><i>mA</i> Milliamps dc (112)</p> <p><i>100</i> RTD 100 Ω (113)</p> <p><i>1000</i> RTD 1,000 Ω (114)</p> <p><i>Pot</i> Potentiometer 1 kΩ (155)</p> <p><i>ther</i> Thermistor (229)</p>	Thermocouple or Thermistor	<p>Instance 1</p> <p>Map 1 Map 2</p> <p>368 368</p>	4005	uint RWES
<p>Analog Input TC Linearization Set the linearization to match the thermocouple wired to this input.</p>	<p><i>B</i> B (11) <i>K</i> K (48)</p> <p><i>C</i> C (15) <i>N</i> N (58)</p> <p><i>D</i> D (23) <i>R</i> R (80)</p> <p><i>E</i> E (26) <i>S</i> S (84)</p> <p><i>F</i> F (30) <i>T</i> T (93)</p> <p><i>J</i> J (46)</p>	J	<p>Instance 1</p> <p>Map 1 Map 2</p> <p>370 370</p>	4006	uint RWES
<p>Analog Input RTD Leads Set to match the number of leads on the RTD wired to this input.</p>	<p><i>2</i> 2 (1)</p> <p><i>3</i> 3 (2)</p>	2	<p>Instance 1</p> <p>Map 1 Map 2</p> <p>372 372</p>	4007	uint RWES
<p>Analog Input Units Set the type of units the sensor will measure.</p>	<p><i>ATP</i> Absolute Temperature (1540)</p> <p><i>rh</i> Relative Humidity (1538)</p> <p><i>Pro</i> Process (75)</p> <p><i>Power</i> Power (73)</p>	Process	<p>Instance 1</p> <p>Map 1 Map 2</p> <p>--- 442</p>	4042	uint RWES

Setup Page

Parameter Name Description	Range	Default	Modbus Relative Address	Parameter ID	Data Type and Access **
Analog Input Scale Low Set the low scale for process inputs. This value, in millivolts, volts or milliamps, will correspond to the Range Low output of this function block.	-100.00 to 1,000.00	0.0	<i>Instance 1</i> Map 1 Map 2 388 388	4015	float RWES
Analog Input Scale High Set the high scale for process inputs. This value, in millivolts, volts or milliamperes, will correspond to the Range High output of this function block.	-100.00 to 1,000.00	20.0	<i>Instance 1</i> Map 1 Map 2 390 390	4016	float RWES
Analog Input Range Low Set the low range for this function block's output.	-1,999.000 to 9,999.000	0.0	<i>Instance 1</i> Map 1 Map 2 392 392	4017	float RWES
Analog Input Range High Set the high range for this function block's output.	-1,999.000 to 9,999.000	9,999	<i>Instance 1</i> Map 1 Map 2 394 394	4018	float RWES
Analog Input Process Error Enable Turn the Process Error Low feature on or off.	OFF Off (62) LOW Low (53)	Off	<i>Instance 1</i> Map 1 Map 2 418 418	4030	uint RWES
Analog Input Process Error Low Value If the process value drops below this value, it will trigger an input error.	-100.00 to 1,000.00	0.0	<i>Instance 1</i> Map 1 Map 2 420 420	4031	float RWES
Analog Input Thermistor Curve Select a curve to apply to the thermistor input.	A Curve A (1451) B Curve B (1452) C Curve C (1453) CUST Custom (180)	Curve A	<i>Instance 1</i> Map 1 Map 2 434 434	4038	uint RWES

Setup Page

Parameter Name Description	Range	Default	Modbus Relative Address	Parameter ID	Data Type and Access **
Analog Input Resistance Range Set the maximum resistance of the thermistor input.	5 5K (1448) 10 10K (1360) 20 20K (1361) 40 40K (1449)	40K	Instance 1 Map 1 Map 2 432 432	4037	uint RWES
Analog Input Filter Filtering smooths out the process signal to both the display and the input. Increase the time to increase filtering. Note: Filter does not ap- ply to the Limit sen- sor but does apply to all other func- tions.	0.0 to 60.0 seconds	0.5	Instance 1 Map 1 Map 2 386 386	4014	float RWES
Analog Input Input Error Latching Turn input error latching on or off. If latching is on, errors must be manually cleared.	0FF Off (62) 0n On (63)	Off	Instance 1 Map 1 Map 2 414 414	4028	uint RWES
Analog Input Display Precision Set the precision of the displayed value.	0 Whole (105) 00 Tenths (94) 000 Hundredths (40) 0000 Thousandths (96)	Whole	Instance 1 Map 1 Map 2 398 398	4020	uint RWES
Analog Input Calibration Offset * Offset the input reading to compen- sate for lead wire resistance or other factors that cause the input reading to vary from the actual process value.	-1,999.000 to 9,999.000°F or units -1,110.555 to 5,555.000°C	0.0	Instance 1 Map 1 Map 2 382 382	4012	float RWES

** R: Read, W: Write, E: EEPROM, S: User Set

Setup Page

Parameter Name Description	Range	Default	Modbus Relative Address	Parameter ID	Data Type and Access **
Analog Input Analog Input Value * View the process value. Note: Ensure that the Error Status (below) indicates no error (61) when reading this value using a field bus protocol. If an error exists, the last known value prior to the error occurring will be returned.	-1,999.000 to 9,999.000°F or units -1,128.000 to 5,537.000°C	----	Instance 1 Map 1 Map 2 360 360	4001	float R
Analog Input Input Error * View the cause of the most recent error.	<i>nonE</i> None (61) <i>OPEn</i> Open (65) <i>Shrt</i> Shorted (127) <i>EPn</i> Measurement Error (140) <i>E.CAL</i> Bad Calibration Data (139) <i>Er.Ab</i> Ambient Error (9) <i>Er.td</i> RTD Error (141) <i>FR.L</i> Fail (32)	----	Instance 1 Map 1 Map 2 362 442	4002	uint R
Lnr SEt Linearization Menu					
Linearization Function Set how this function will linearize Source A.	<i>OFF</i> Off (62) <i>intE</i> Interpolated (1482)	Off	Instance 1 Map 1 Map 2 ---- 3568	34005	uint RWES
Linearization Units Set the units of the output value.	<i>Src</i> Source (1539) <i>nonE</i> None (61) <i>AtP</i> Absolute Temperature (1540) <i>r.tP</i> Relative Temperature (1541) <i>PLUr</i> Power (73) <i>Pro</i> Process (75) <i>rh</i> Relative Humidity (1538)	Source	Instance 1 Map 1 Map 2 ---- 3616	34029	uint RWES

** R: Read, W: Write, E: EEPROM, S: User Set

Setup Page

Parameter Name Description	Range	Default	Modbus Relative Address	Parameter ID	Data Type and Access **
Linearization Input Point 1 Set the value that will be mapped to output 1.	-1,999.000 to 9,999.000	0.0	Instance 1 Map 1 Map 2 - - - - 3574	34008	float RWES
Linearization Output Point 1 Set the value that will be mapped to input 1.	-1,999.000 to 9,999.000	0.0	Instance 1 Map 1 Map 2 - - - - 3594	34018	float RWES
Linearization Input Point 2 Set the value that will be mapped to output 2.	-1,999.000 to 9,999.000	1.0	Instance 1 Map 1 Map 2 - - - - 3576	34009	float RWES
Linearization Output Point 2 Set the value that will be mapped to input 2.	-1,999.000 to 9,999.000	1.0	Instance 1 Map 1 Map 2 - - - - 3596	34019	float RWES
Linearization Input Point 3 Set the value that will be mapped to output 3.	-1,999.000 to 9,999.000	2.0	Instance 1 Map 1 Map 2 - - - - 3578	34010	float RWES
Linearization Output Point 3 Set the value that will be mapped to input 3.	-1,999.000 to 9,999.000	2.0	Instance 1 Map 1 Map 2 - - - - 3598	34020	float RWES
Linearization Input Point 4 Set the value that will be mapped to output 4.	-1,999.000 to 9,999.000	3.0	Instance 1 Map 1 Map 2 - - - - 3580	34011	float RWES
Linearization Output Point 4 Set the value that will be mapped to input 4.	-1,999.000 to 9,999.000	3.0	Instance 1 Map 1 Map 2 - - - - 3600	34021	float RWES
Linearization Input Point 5 Set the value that will be mapped to output 5.	-1,999.000 to 9,999.000	4.0	Instance 1 Map 1 Map 2 - - - - 3582	34012	float RWES

** R: Read, W: Write, E: EEPROM, S: User Set

Setup Page

Parameter Name Description	Range	Default	Modbus Relative Address	Parameter ID	Data Type and Access **
Linearization Output Point 5 Set the value that will be mapped to input 5.	-1,999.000 to 9,999.000	4.0	Instance 1 Map 1 Map 2 - - - - 3602	34022	float RWES
Linearization Input Point 6 Set the value that will be mapped to output 6.	-1,999.000 to 9,999.000	5.0	Instance 1 Map 1 Map 2 - - - - 3584	34013	float RWES
Linearization Output Point 6 Set the value that will be mapped to input 6.	-1,999.000 to 9,999.000	5.0	Instance 1 Map 1 Map 2 - - - - 3604	34023	float RWES
Linearization Input Point 7 Set the value that will be mapped to output 7.	-1,999.000 to 9,999.000	6.0	Instance 1 Map 1 Map 2 - - - - 3586	34014	float RWES
Linearization Output Point 7 Set the value that will be mapped to input 7.	-1,999.000 to 9,999.000	6.0	Instance 1 Map 1 Map 2 - - - - 3606	34024	float RWES
Linearization Input Point 8 Set the value that will be mapped to output 8.	-1,999.000 to 9,999.000	7.0	Instance 1 Map 1 Map 2 - - - - 3588	34015	float RWES
Linearization Output Point 8 Set the value that will be mapped to input 8.	-1,999.000 to 9,999.000	7.0	Instance 1 Map 1 Map 2 - - - - 3608	34025	float RWES
Linearization Input Point 9 Set the value that will be mapped to output 9.	-1,999.000 to 9,999.000	8.0	Instance 1 Map 1 Map 2 - - - - 3590	34016	float RWES
Linearization Output Point 9 Set the value that will be mapped to input 9.	-1,999.000 to 9,999.000	8.0	Instance 1 Map 1 Map 2 - - - - 3610	34026	float RWES

** R: Read, W: Write, E: EEPROM, S: User Set

Setup Page

Parameter Name Description	Range	Default	Modbus Relative Address	Parameter ID	Data Type and Access **
Linearization Input Point 10 Set the value that will be mapped to output 10.	-1,999.000 to 9,999.000	9.0	Instance 1 Map 1 Map 2 - - - - 3592	34017	float RWES
Linearization Output Point 10 Set the value that will be mapped to input 10.	-1,999.000 to 9,999.000	9.0	Instance 1 Map 1 Map 2 - - - - 3612	34027	float RWES
P_u SEt Process Value Menu					
Process Value Function Set the function that will be applied to the source or sources.	oFF Off (62) ALt Pressure to Altitude (1649)***	Off	Instance 1 Map 1 Map 2 - - - - 3320	26021	uint RWES
Process Value Pressure Units*** If Process Value function is set for Pressure to Altitude units, define units of measure for conversion.	PSI Pounds per Square Inch (1671) PASC Pascal (1674) ALtPn Atmosphere (1675) mBar Millibar (1672) Torr Torr (1673)	PSI	Instance 1 Map 1 Map 2 - - - - 3334	26028	uint RWES
Process Value Altitude Units*** If Process Value function is set for Pressure to Altitude units, define units of measure for conversion.	HFt Kilofeet (1677) Ft Feet (1676)	HFt	Instance 1 Map 1 Map 2 - - - - 3336	26029	uint RWES
Process Value Barometric Pressure*** If Process Value function is set for Wet Bulb / Dry Bulb, define pressure value used for humidity calculation.	10.0 to 16.0	14.7	Instance 1 Map 1 Map 2 - - - - 3338	26030	float RWES

** R: Read, W: Write, E: EEPROM, S: User Set

Setup Page

Parameter Name Description	Range	Default	Modbus Relative Address	Parameter ID	Data Type and Access **
Process Value Filter Filtering smooths out the output signal of this function block. Increase the time to increase filtering.	0.0 to 60.0 seconds	0.0	Instance 1 Map 1 Map 2 - - - - 3330	26026	float RWES

*** Pressure Altitude calculation is based on the International Standard Atmosphere 1976

d i o

S E t

Digital Input/Output Menu

Digital Input/Output (5 to 6) Direction Set this function to operate as an input or output.	o u t P e Output (68) i n Input Dry Contact (44) i n Input Voltage (193)	Output	Instance 5 Map 1 Map 2 1000 1120 Offset to next instance (Map 1 & Map 2) equals +30	6001	uint RWES
Digital Output (5 to 6) Function Select what function will drive this output.	o ff Off (62) a l arm (6) h e at (36) c o ol (20) t e .o 1 Timer Event Output 1 (1951) t e .o 2 Timer Event Output 2 (1952) t e .o 3 Timer Event Output 3 (1953) e n t a Profile Event Out A (233) e n t b Profile Event Out B (234) h e r Heater Error (184)	Off	Instance 5 Map 1 Map 2 1008 1128 Offset to next instance (Map 1 & Map 2) equals +30	6005	uint RWES
Digital Output (5 to 6) Output Function Instance Set the instance of the function selected above.	1 to 4	1	Instance 5 Map 1 Map 2 1010 1130 Offset to next instance (Map 1 & Map 2) equals +30	6006	uint RWES

** R: Read, W: Write, E: EEPROM, S: User Set

Setup Page

Parameter Name Description	Range	Default	Modbus Relative Address	Parameter ID	Data Type and Access **
Digital Output (5 to 6) Time Base Type Set the time base type. This parameter is only used with PID control, but can be set any-time.	<i>FtB</i> Fixed Time Base (34) <i>VtB</i> Variable Time Base (103)	Fixed Time Base	Instance 5 Map 1 Map 2 1002 1122 Offset to next instance (Map 1 & Map 2) equals +30	6002	uint RWES
Digital Output (5 to 6) Fixed Time Base Set the time base for fixed-time-base control. Note: Modbus Map 1 has instances 5 through 8 only	0.1 to 60.0 seconds	1.0	Instance 5 Map 1 Map 2 1004 1124 Offset to next instance (Map 1 & Map 2) equals +30	6003	float RWES
Digital Output (5 to 6) Low Power Scale The power output will never be less than the value specified and will represent the value at which output scaling begins.	0.0 to 100.0%	0.0	Instance 5 Map 1 Map 2 1016 1136 Offset to next instance (Map 1 & Map 2) equals +30	6009	float RWES
Digital Output (5 to 6) High Power Scale The power output will never be greater than the value specified and will represent the value at which output scaling stops.	0.0 to 100.0%	100.0	Instance 5 Map 1 Map 2 1018 1138 Offset to next instance (Map 1 & Map 2) equals +30	6010	float RWES
Digital Input (5 to 6) Active Level Select which action will be interpreted as a true state.	<i>High</i> High (37) <i>Low</i> Low (53)	High	Instance 5 Map 1 Map 2 1320 1560 Offset to next instance (Map 1 & Map 2) equals +20	10001	uint RW

** R: Read, W: Write, E: EEPROM, S: User Set

Setup Page

Parameter Name Description	Range	Default	Modbus Relative Address	Parameter ID	Data Type and Access **
<p>Digital Input (7 to 12) Active Level Select which action will be interpreted as a true state.</p> <p>Note: Modbus Map 1 has instances 7 and 8 only</p>	<p><i>h i g h</i> High (37) <i>L o w</i> Low (53)</p>	High	<p>Instance 7 Map 1 Map 2 1400 1640</p> <p>Offset to next instance Map 2 equals +20</p>	10001	uint RW
<p>Digital Input (5 to 6) Action Function Select the function that will be triggered by a true state for Digital Inputs 5 to 6.</p>	<p><i>n o n e</i> None (61) <i>S t a r t</i> Start Step (1077) <i>P r o f i l e</i> Profile Start/ Stop, level triggered (208) <i>P r o f</i> Start Profile, edge triggered (196) <i>P h o l d</i> Profile Hold/ Resume, level triggered (207) <i>P r o f D i s a b l e</i> Profile Disable, level triggered (206) <i>t u n e +</i> TRU-TUNE+® Disable, level triggered (219) <i>o f f</i> Switch Control Loop Off, level triggered (90) <i>M a n u a l</i> Manual, level triggered (54) <i>t u n e</i> Tune, edge triggered (98) <i>i d l e</i> Idle Set Point, level triggered (107) <i>F o r c e</i> Force Alarm to occur, level triggered (218) <i>R o f f</i> Control Loops Off and Alarms to Non-alarm State, level triggered (220) <i>S i l e n c e</i> Silence Alarms, edge triggered (108) <i>A l a r m</i> Alarm Reset, edge triggered (6) <i>K e y p a d</i> Keypad Lock-out, level triggered (217) <i>u s e r</i> User Set Restore, edge triggered (227)</p>	None	<p>Instance 5 Map 1 Map 2 1324 1564</p> <p>Offset to next instance (Map 1 & Map 2) equals +20</p>	10003	uint RWES

Setup Page

Parameter Name Description	Range	Default	Modbus Relative Address	Parameter ID	Data Type and Access **
Digital Input (5 to 6) Function Instance Select which Digital Input will be triggered by a true state.	0 to 40	0	Instance 5 Map 1 Map 2 1326 1566 Offset to next instance (Map 1 & Map 2) equals +20	10004	uint RWES
Loop Set Control Loop Menu					
Control Loop Heat Algorithm Set the heat control method.	oFF Off (62) P id PID (71) oNoF On-Off (64)	PID	Instance 1 Map 1Map 2 1884 2364	8003	uint RWES
Control Loop Cool Algorithm Set the cool control method.	oFF Off (62) P id PID (71) oNoF On-Off (64)	Off	Instance 1 Map 1Map 2 1886 2366	8004	uint RWES
Control Loop Cool Output Curve Select a cool output curve to change the responsiveness of the system.	oFF Off (62) [r.A Non-linear Curve 1 (214) [r.b Non-linear Curve 2 (215)	Off	Instance 1 Map 1Map 2 1888 2368	8038	uint RWES
Control Loop Heat Proportional Band * Set the PID proportional band for the heat outputs.	0.001 to 9,999.000°F or units 0.001 to 5,555.000°C	25.0°F or units 14.0°C	Instance 1 Map 1Map 2 1890 2370	8009	float RWES
Control Loop On / Off Heat Hysteresis * Set the control switching hysteresis for on-off control. This determines how far into the “on” region the process value needs to move before the output turns on.	0.001 to 9,999.000°F or units 0.001 to 5,555.000°C	3.0°F or units 2.0°C	Instance 1 Map 1 ap 2 1900 2380	8010	float RWES
** R: Read, W: Write, E: EEPROM, S: User Set					

Setup Page

Parameter Name Description	Range	Default	Modbus Relative Address	Parameter ID	Data Type and Access **
Control Loop Cool Proportional Band * Set the PID pro- portional band for the cool outputs.	0.001 to 9,999.000°F or units 0.001 to 5,555.000°C	25.0°F or units 14.0°C	Instance 1 Map 1Map 2 1892 2372	8012	float RWES
Control Loop On/Off Cool Hysteresis * Set the control switching hys- teresis for on-off control. This deter- mines how far into the “on” region the process value needs to move before the output turns on.	0.001 to 9,999.000°F or units 0.001 to 5,555.000°C	3.0°F or units 2.0°C	Instance 1 Map 1Map 2 1902 2382	8013	float RWES
Control Loop Time Integral * Set the PID inte- gral for the out- puts.	0 to 9,999 seconds per repeat	180 sec- onds per repeat	Instance 1 Map 1 Map 2 1894 2374	8006	float RWES
Control Loop Time Derivative * Set the PID de- rivative time for the outputs.	0 to 9,999 seconds	0 seconds	Instance 1 Map 1Map 2 1896 2376	8007	float RWES
Control Loop (1 to 2) Dead Band * Set the offset to the proportional band. With a nega- tive value, both heating and cool- ing outputs are active when the process value is near the set point. A positive value keeps heating and cooling outputs from fighting each other.	-1,000.0 to 1,000.0°F or units -556 to 556°C	0.0	Instance 1 Map 1Map 2 1898 2378 Instance 2 Map 1Map 2 1968 2448	8008	float RWES

* These parameters/prompts are available in these menus with firmware revisions 11.0 and above.

** R: Read, W: Write, E: EEPROM, S: User Set

Setup Page

Parameter Name Description	Range	Default	Modbus Relative Address	Parameter ID	Data Type and Access **
Control Loop TRU-TUNE+® Enable Enable or disable the TRU-TUNE+ adaptive tuning feature.	<i>no</i> No (59) <i>YES</i> Yes (106)	No	<i>Instance 1</i> Map 1Map 2 1910 2390	8022	uint RWES
Control Loop TRU-TUNE+ Band Set the range, centered on the set point, within which TRU-TUNE+ will be in effect. Use this function only if the controller is unable to adaptive tune automatically.	0 to 100	0	<i>Instance 1</i> Map 1Map 2 1912 2392	8034	uint RWES
Control Loop TRU-TUNE+ Gain Select the responsiveness of the TRU-TUNE+ adaptive tuning calculations. More responsiveness may increase overshoot.	1 to 6	3	<i>Instance 1</i> Map 1Map 2 1914 2394	8035	uint RWES
Control Loop Autotune Set Point * Set the set point that the autotune will use, as a percentage of the current set point.	50 to 200%	90.0	<i>Instance 1</i> Map 1Map 2 1918 2398	8025	float RWES
Control Loop Autotune Aggressiveness Select the aggressiveness of the autotuning calculations.	<i>Undr</i> Under damped (99) <i>Cr it</i> Critical damped (21) <i>ouEr</i> Over damped (69)	Critical	<i>Instance 1</i> Map 1Map 2 1916 2396	8024	uint RWES
Control Loop Peltier Delay Set a value that will cause a delay when switching from heat PID mode to cool PID mode.	0.0 to 5.0 seconds	0.0	<i>Instance 1</i> Map 1Map 2 1934 2414	8051	float RWES

* These parameters/prompts are available in these menus with firmware revisions 11.0 and above.

** R: Read, W: Write, E: EEPROM, S: User Set

Setup Page

Parameter Name Description	Range	Default	Modbus Relative Address	Parameter ID	Data Type and Access **
Control Loop Auto-to-Manual Power Select what the controller outputs will do when the user switches control to manual mode.	OFF Off, sets output power to 0% (62) BPLS Bumpless transfer, maintains same output power, if it was less than 75% and stable, otherwise 0% (14) FRN Fixed Power, sets output power to Fixed Power setting (54) USER User, sets output power to last open-loop set point the user entered (100)	User	Instance 1 Map 1Map 2 2182 2662	7012	uint RWES
Control Loop Input Error Power Select what the controller outputs will do when an input error switches control to manual mode.	OFF Off, sets output power to 0% (62) BPLS Bumpless transfer, maintains same output power, if it was less than 75% and stable, otherwise 0% (14) FRN Fixed Power, sets output power to Fixed Power setting (54) USER User, sets output power to last open-loop set point the user entered (100)	User	Instance 1 Map 1Map 2 2184 2664	7013	uint RWES
Control Loop Fixed Power Set the manual output power level that will take effect if an input error failure occurs while User Failure Action is set to Fixed Power.	Set Point Open Loop Limit Low to Set Point Open Loop Limit High (Setup Page)	0.0	Instance 1 Map 1Map 2 2180 2660	7011	float RWES

* These parameters/prompts are available in these menus with firmware revisions 11.0 and above.

** R: Read, W: Write, E: EEPROM, S: User Set

Setup Page

Parameter Name Description	Range	Default	Modbus Relative Address	Parameter ID	Data Type and Access **
Control Loop Open Loop Detect Enable Select Yes to detect conditions that prevent the process from changing in specified time frame by a specified amount when PID power is at 100%. An open loop detect error will disable the control loop.	<i>no</i> No (59) <i>YES</i> Yes (106)	No	Instance 1 Map 1Map 2 1922 2402	8039	uint RWES
Control Loop Open Loop Error Status View the cause of the most recent error.	none (61) Open Loop (1274) Reversed Sensor (1275)	- - - -	Instance 1 Map 1Map 2 1928 2408	8048	uint R
Control Loop Open Loop Detect Time Process must deviate by the Open Loop Detect Deviation value in the specified time, while at 100% PID power, otherwise an Open Loop Detect event is triggered.	0 to 3,600 seconds	240	Instance 1 Map 1Map 2 1924 2404	8040	uint RWES
Control Loop Open Loop Detect Deviation Process must deviate by this value in the Open Loop Detect Time while at 100% PID power to prevent an open loop error.	-1,999.000 to 9,999.000°F or units -1,110.555 to 5,555.000°C	10.0°F or units 6.0°C	Instance 1 Map 1Map 2 1926 2406	8041	float RWES
Control Loop Ramp Action Select when the controller's set point will ramp to the defined end set point.	<i>oFF</i> Off (62) <i>StR</i> Startup (88) <i>StPt</i> Set Point Change (85) <i>both</i> Both (13)	Off	Instance 1 Map 1Map 2 2186 2666	7014	uint RWES

* These parameters/prompts are available in these menus with firmware revisions 11.0 and above.

** R: Read, W: Write, E: EEPROM, S: User Set

Setup Page

Parameter Name Description	Range	Default	Modbus Relative Address	Parameter ID	Data Type and Access **
Control Loop Ramp Scale Select the scale of the ramp rate.	<i>hour</i> Hours (39) <i>min</i> Minutes (57)	Minutes	Instance 1 Map 1Map 2 2188 2668	7015	uint RWES
Control Loop Ramp Rate Set the rate for the set point ramp. Set the time units for the rate with the Ramp Scale pa- rameter.	0.0 to 9,999.000°F or units 0.0 to 5,555.000°C	1.0°F or units 1.0°C	Instance 1 Map 1Map 2 2192 2672	7017	float RWES
Control Loop Minimum Set Point Set the minimum value of the closed loop set point range.	-1,999.000 to 9,999.000°F or units -1,128.000 to 5,537.000°C	-1,999°F or units -1,128°C	Instance 1 Map 1Map 2 2164 2644 Instance 2 Map 1Map 2 2244 2724	7003	float RWES
Control Loop Maximum Set Point Set the maximum value of the closed loop set point range.	-1,999.000 to 9,999.000°F or units -1,128.000 to 5,537.000°C	9,999°F or units 5,537°C	Instance 1 Map 1Map 2 2166 2646	7004	float RWES
Control Loop Set Point * Set the set point that the controller will automatically control to.	-1,999.000 to 9,999.000°F or units -1,128.000 to 5,537.000°C	75.0°F or units 24.0°C	Instance 1 Map 1Map 2 2160 2640	7001	float RWES
Control Loop Idle Set Point * Set a closed loop set point that can be triggered by an event state.	-1,999.000 to 9,999.000°F or units -1,128.000 to 5,537.000°C	75.0°F or units 24.0°C	Instance 1 Map 1Map 2 2176 2656	7009	float RWES
Control Loop Minimum Manual Power Set the minimum value of the open- loop set point range.	-100.0 to 100.0%	-100	Instance 1 Map 1Map 2 2168 2648	7005	float RWES
Control Loop Maximum Manual Power Set the maximum value of the open- loop set point range.	-100.0 to 100.0%	100	Instance 1 Map 1Map 2 2170 2650	7006	float RWES

* These parameters/prompts are available in these menus with firmware revisions 11.0 and above.
** R: Read, W: Write, E: EEPROM, S: User Set

Setup Page

Parameter Name Description	Range	Default	Modbus Relative Address	Parameter ID	Data Type and Access **
Control Loop Manual Power * Set a fixed level of output power when in manual (open-loop) mode.	-100.0 to 100.0% (heat and cool) 0 to 100.0% (heat only) -100.0 to 0% (cool only)	0.0	Instance 1 Map 1 Map 2 2162 2642	7002	float RWES
Control Loop Control Mode * Select the method that this loop will use to control.	OFF Off (62) AUTO Auto (10) MAN Manual (54)	Auto	Instance 1 Map 1 Map 2 1880 2360	8001	uint RWES

oPt

SEt

Output Menu

Output Digital (1 to 2) Function Select what function will drive this output.	OFF Off (62) ALPN Alarm (6) HEAt Heat (36) COol Cool (20) tEo1 Timer Event 1 (1951) tEo2 Timer Event 2 (1952) tEo3 Timer Event 3 (1953) EntA Profile Event Out A (233) EntB Profile Event Out B (234) hEr Heater Error (184)	Output 1 - Heat Output 2 - Alarm	Instance 1 Map 1 Map 2 888 1008 Offset to next instance (Map 1 & Map 2) equals +30	6005	uint RWES
Output Digital (1 to 2) Output Function Instance Set the instance of the function selected above.	1 to 4	1	Instance 1 Map 1 Map 2 890 1010 Offset to next instance (Map 1 & Map 2) equals +30	6006	uint RWES
Output Digital (1 to 2) Time Base Type Set the time base type. This parameter is only used with PID control, but can be set anytime.	FtB Fixed Time Base (34) vTb Variable Time Base (103)	Fixed Time Base	Instance 1 Map 1 Map 2 882 1002 Offset to next instance (Map 1 & Map 2) equals +30	6002	uint RWES

* These parameters/prompts are available in these menus with firmware revisions 11.0 and above.

** R: Read, W: Write, E: EEPROM, S: User Set

Setup Page

Parameter Name Description	Range	Default	Modbus Relative Address	Parameter ID	Data Type and Access **
Output Digital (1 to 2) Fixed Time Base Set the time base for fixed-time-base control.	0.1 to 60.0 seconds (solid-state relay or switched dc) 5.0 to 60.0 seconds (mechanical relay or NO-ARC power control)	1.0 sec. for SSR or swdc 5.0 for relay	Instance 1 Map 1Map 2 884 1004 Offset to next instance (Map 1 & Map 2) equals +30	6003	float RWES
Output Digital (1 to 2) Low Power Scale The power output will never be less than the value specified and will represent the value at which output scaling begins.	0.0 to 100.0%	0.0%	Instance 1 Map 1Map 2 896 1016 Offset to next instance (Map 1 & Map 2) equals +30	6009	float RWES
Output Digital (1 to 2) High Power Scale The power output will never be greater than the value specified and will represent the value at which output scaling stops.	0.0 to 100.0%	100.0%	Instance 1 Map 1Map 2 898 1018 Offset to next instance (Map 1 & Map 2) equals +30	6010	float RWES
Output Process (1) Type Select whether the process output will operate in volts or milliamps.	v o l t s Volts (104) m i l l i a m p s Milliamps (112)	Volts	Instance 1 Map 1Map 2 720 840	18001	uint RWES
Output Process (1) Function Set the type of function that will drive this output.	o f f Off (62) h e a t Heat (36) c o o l Cool (20) d u p l Duplex (212) a l a r m Alarm (6) e n t . a Profile Event Out A (233) e n t . b Profile Event Out B (234) r e t r a n s m i t Retransmit (213)	Off	Instance 1 Map 1Map 2 722 842	18002	uint RWES

* These parameters/prompts are available in these menus with firmware revisions 11.0 and above.

** R: Read, W: Write, E: EEPROM, S: User Set

Setup Page

Parameter Name Description	Range	Default	Modbus Relative Address	Parameter ID	Data Type and Access **
Output Process (1) Retransmit Source Select the value that will be retransmitted.	<i>A</i> , Analog Input (142) <i>SPt</i> Set Point (85) <i>Cur</i> Current Sample and hold (22) <i>Pu</i> Process Value (241)	Analog Input	<i>Instance 1</i> Map 1Map 2 724 844	18003	uint RWES
Output Process (1) Function Instance Set the instance of the function selected above.	1 to 4	1	<i>Instance 1</i> Map 1Map 2 726 846	18004	uint RWES
Output Process (1) Scale Low Set the scale low for process output in electrical units. This value; in volts or milliamps, will correspond to 0% PID power output or range low retransmit output.	-100.0 to 100.0	0.00	<i>Instance 1</i> Map 1Map 2 736 856	18009	float RWES
Output Process (1) Scale High Set the scale high for process output in electrical units. This value; in volts or milliamps, will correspond to 100% PID power output or range high retransmit output.	-100.0 to 100.0	10.00	<i>Instance 1</i> Map 1Map 2 738 858	18010	float RWES
Output Process (1) Range Low Set the minimum value of the retransmit value range in process units. When the retransmit source is at this value, the retransmit output will be at its Scale Low value.	-1,999.000 to 9,999.000°F or units -1,128.000 to 5,537.000°C	0.0°F or units -18°C	<i>Instance 1</i> Map 1Map 2 740 860	18011	float RWES

* These parameters/prompts are available in these menus with firmware revisions 11.0 and above.

** R: Read, W: Write, E: EEPROM, S: User Set

Setup Page

Parameter Name Description	Range	Default	Modbus Relative Address	Parameter ID	Data Type and Access **
Output Process (1) Range High Set the maximum value of the retransmit value range in process units. When the retransmit source is at this value, the retransmit output will be at its Scale High value.	-1,999.000 to 9,999.000°F or units -1,128.000 to 5,537.000°C	100.0°F or units 38.0°C	Instance 1 Map 1 Map 2 742 862	18012	float RWES
Output Process (1) Calibration Offset Set an offset value for a process output.	-1,999.000 to 9,999.000°F or units -1,110.555 to 5,555.000°C	0.0°F or units 0.0°C	Instance 1 Map 1 Map 2 732 852	18007	float RWES
ALM SET Alarm Menu					
Alarm (1 to 4) Type Select whether the alarm trigger is a fixed value or will track the set point.	OFF Off (62) Pr.AL Process Alarm (76) dE.AL Deviation Alarm (24)	Off	Instance 1 Map 1 Map 2 1508 1908 Offset to next instance (Map 1 +50, Map 2 +60)	9015	uint RWES
Alarm (1 to 4) Alarm Source Select what will trigger this alarm.	nonE None (61) A,I Analog Input (142) Lnr Linearization (238) Pu Process Value (241) PuJr Power (73)		Instance 1 Map 1 Map 2 1512 1912 Offset to next instance (Map 1 +50, Map 2 +60)	9017	uint RWES
Alarm (1 to 4) Hysteresis Set the hysteresis for an alarm. This determines how far into the safe region the process value needs to move before the alarm can be cleared.	0.001 to 9,999.000°F or units 0.001 to 5,555.000°C	1.0°F or units 1.0°C	Instance 1 Map 1 Map 2 1484 1884 Offset to next instance (Map 1 equals +50, Map 2 +60)	9003	float RWES

* These parameters/prompts are available in these menus with firmware revisions 11.0 and above.
 ** R: Read, W: Write, E: EEPROM, S: User Set

Setup Page

Parameter Name Description	Range	Default	Modbus Relative Address	Parameter ID	Data Type and Access **
Alarm (1 to 4) Logic Select what the output condition will be during the alarm state.	<i>ALe</i> Energize on alarm (17) <i>ALo</i> De-energize on alarm (66)	Close On Alarm	Instance 1 Map 1Map 2 1488 1888 Offset to next instance (Map 1 +50, Map 2 +60)	9005	uint RWES
Alarm (1 to 4) Sides Select which side or sides will trigger this alarm.	<i>both</i> Both (13) <i>High</i> High (37) <i>Low</i> Low (53)	Both	Instance 1 Map 1Map 2 1486 1886 Offset to next instance (Map 1 +50, Map 2 +60)	9004	uint RWES
Alarm (1 to 4) Low Set Point If Type (Setup Page, Alarm Menu) is set to: Process - set the process value that will trigger a low alarm. Deviation - set the span of units from the closed loop set point that will trigger a low alarm. A negative set point represents a value below closed loop set point. A positive set point represents a value above closed loop set point.	-1,999.000 to 9,999.000°F or units -1,128.000 to 5,537.000°C	32.0°F or units 0.0°C	Instance 1 Map 1Map 2 1482 1882 Offset to next instance (Map 1 +50, Map 2 +60)	9002	float RWES
* These parameters/prompts are available in these menus with firmware revisions 11.0 and above. ** R: Read, W: Write, E: EEPROM, S: User Set					

Setup Page

Parameter Name Description	Range	Default	Modbus Relative Address	Parameter ID	Data Type and Access **
Alarm (1 to 4) High Set Point If Type (Setup Page, Alarm Menu) is set to: Process - set the process value that will trigger a high alarm. Deviation - set the span of units from the closed loop set point that will trigger a high alarm.	-1,999.000 to 9,999.000°F or units -1,128.000 to 5,537.000°C	300.0°F or units 150.0°C	Instance 1 Map 1Map 2 1480 1880 Offset to next instance (Map 1) equals +50 Offset to next instance (Map 2) equals +60	9001	float RWES
Alarm (1 to 4) Latching Turn latching on or off. A latched alarm has to be turned off by the user.	nLAL Non-Latching (60) LAL Latching (49)	Non-Latching	Instance 1 Map 1Map 2 1492 1892 Offset to next instance (Map 1 equals +50, for Map 2 equals +60)	9007	uint RWES
Alarm (1 to 4) Blocking Select when an alarm will be blocked. After startup and/or after the set point changes, the alarm will be blocked until the process value enters the normal range.	oFF Off (62) StR Startup (88) StPt Set Point (85) both Both (13)	Off	Instance 1 Map 1Map 2 1494 1894 Offset to next instance (Map 1 equals +50, for Map 2 equals +60)	9008	uint RWES
Alarm (1 to 4) Silencing Turn silencing on to allow the user to disable this alarm.	oFF Off (62) on On (63)	Off	Instance 1 Map 1Map 2 1490 1890 Offset to next instance (Map 1 equals +50, for Map 2 equals +60)	9006	uint RWES

* These parameters/prompts are available in these menus with firmware revisions 11.0 and above.
 ** R: Read, W: Write, E: EEPROM, S: User Set

Setup Page

Parameter Name Description	Range	Default	Modbus Relative Address	Parameter ID	Data Type and Access **
Alarm (1 to 4) Display Display an alarm message when an alarm is active.	<i>oFF</i> Off (62) <i>on</i> On (63)	On	Instance 1 Map 1Map 2 1510 1910 Offset to next instance (Map 1 equals +50, for Map 2 equals +60)	9016	uint RWES
Alarm (1 to 4) Delay Time Set the span of time that the alarm will be delayed after the process value exceeds the alarm set point.	0 to 9,999 seconds	0	Instance 1 Map 1Map 2 1520 1920 Offset to next instance (Map 1 equals +50, for Map 2 equals +60)	9021	uint RWES
Alarm (1 to 4) Clear Alarm Write to this register to clear an alarm Note: If an alarm is set-up to latch when active <i>ALr</i> will appear on the display.	<i>CLr</i> Clear (0) <i>Ignr</i> Ignore (204)	----	Instance 1 Map 1Map 2 1504 1904 Offset to next instance (Map1 1 equals +50, Map 2 equals +60)	9013	uint W
Alarm (1 to 4) Silence Alarm Write to this register to silence an alarm Note: If an alarm is setup to silence alarm when active <i>ASir</i> will appear on the display.	<i>SIL</i> Silence (1010)	----	Instance 1 Map 1Map 2 1506 1906 Offset to next instance (Map1 1 equals +50, Map 2 equals +60)	9014	uint W
Alarm (1 to 4) Alarm State Current state of alarm	<i>Str</i> Startup (88) <i>nonE</i> None (61) <i>BLo</i> Blocked (12) <i>ALL</i> Alarm low (8) <i>ALh</i> Alarm high (7) <i>ALe</i> Error (28)	----	Instance 1 Map 1Map 2 1496 1896 Offset to next instance (Map1 1 equals +50, Map 2 equals +60)	9009	uint R

* These parameters/prompts are available in these menus with firmware revisions 11.0 and above.
 ** R: Read, W: Write, E: EEPROM, S: User Set

Setup Page

Parameter Name Description	Range	Default	Modbus Relative Address	Parameter ID	Data Type and Access **
Timer Menu					
Timer (1) Timer Enable Enable the timer function.	YES Yes (106) no No (59)	Yes	Instance 1 Map 1Map 2 4626 8556	31029	uint RWES
Timer (1) Timer Start Method Select what will start the timer.	immediate Immediate (1049) rdy Ready Band (1942) rdyA Ready Ack (1950) PLUR Power (73)	Immediate	Instance 1 Map 1Map 2 4628 8558	31030	uint RWES
Timer (1) Source Function A Select which input will start or terminate the timer.	FUn Function Key (1001) none None (61) dio Digital I/O (1142)	Function Key	Instance 1 Map 1Map 2 4570 8500	31001	uint RWES
Timer (1) Source Instance A Select an instance of Function A.	1 to 24	8	Instance 1 Map 1Map 2 4574 8504	31003	uint RWES
Timer (1) Source Function C Select the analog source for the ready band.	PV Process Value (241) none None (61) AI Analog Input (142) Lnr Linearization (238)	Process Value	Instance 1 Map 1Map 2 4630 8560	31031	uint RWES
Timer (1) Source Instance C Select an instance of Function C.	1 to 24	1	Instance 1 Map 1Map 2 4634 8564	31033	uint RWES
Timer (1) Source Function D Select which input will acknowledge the ready band.	FUn Function Key (1001) none None (61) dio Digital I/O (1142)	Function Key	Instance 1 Map 1Map 2 4632 8562	31032	uint RWES
Timer (1) Source Instance D Select an instance of Function D.	1 to 24	7	Instance 1 Map 1Map 2 4636 8566	31034	uint RWES
* These parameters/prompts are available in these menus with firmware revisions 11.0 and above. ** R: Read, W: Write, E: EEPROM, S: User Set					

Setup Page

Parameter Name Description	Range	Default	Modbus Relative Address	Parameter ID	Data Type and Access **
Timer (1) Time Remaining Display the time remaining on the timer.	00:00 to 99:59	7	- - - -	31021	string R
Timer (1) Ready Band State Display whether the process value is in the ready band.	YES Yes (106) NO No (59)	- - - -	Instance 1 Map 1Map 2 4612 8542	31022	uint R
Timer (1) Ready Band Set the how close the process value must be to the closed loop timer set point to be in the ready band.	0.000 to 9999.000°F or units 0.000 to 5555.000°C	5.000	Instance 1 Map 1Map 2 4614 8544	31023	float RWES
Timer (1) Time Format Select the time format.	MMSS Time Minutes:Seconds (1943) HHMM Time Hours:Minutes (1944)	Time Minutes: Sec- onds	Instance 1 Map 1Map 2 4616 8546	31024	uint RWES
Timer (1) Hours Set the timer period hours.	0 to 99	0	Instance 1 Map 1Map 2 4618 8548	31025	uint RWES
Timer (1) Minutes Set the timer period minutes.	0 to 59	0	Instance 1 Map 1Map 2 4620 8550	31026	uint RWES
Timer (1) Seconds Set the timer period seconds.	0 to 59	10	Instance 1 Map 1Map 2 4622 8552	31027	uint RWES
Timer (1) Closed Loop Timer Set Point Set the set point that will be in effect during the timer period.	-1999.000 to 9999.000°F or units -1110.555 to 5555.000°C	75	Instance 1 Map 1Map 2 4624 8554	31028	float RWES

* These parameters/prompts are available in these menus with firmware revisions 11.0 and above.

** R: Read, W: Write, E: EEPROM, S: User Set

Setup Page

Parameter Name Description	Range	Default	Modbus Relative Address	Parameter ID	Data Type and Access **
Timer (1) Signal Time Set the period of time that a signal output to be activated after the timer period is complete. Assign a digital output for this function in Timer Event Output 3.	1 to 3600 Seconds	1	<i>Instance 1</i> Map 1Map 2 4658 8588	31045	uint RWES
9LbL 5Et Global Menu					
Global Display Units Select which scale to use for temperature.	F °F (30) C °C (15)	°F	<i>Instance 1</i> Map 1Map 2 1838 2308	3005	uint RWES
Global AC Line Frequency Set the frequency to the applied ac line power source.	50 50 Hz (3) 60 60 Hz (4)	60 Hz	<i>Instance 1</i> Map 1Map 2 886 1006	1034	uint RWES
Global Ramping Type	r A t E Rate (81) t , Time (143)	Time	<i>Instance 1</i> Map 1Map 2 - - - - 4414	22038	uint RWE
Global Profile Type Set the profile startup to be based on a set point or a process value.	S t P t Set Point (85) P r o Process (75)	Set Point	<i>Instance 1</i> Map 1Map 2 2534 4354	22008	uint RWE
Global Guaranteed Soak Enable Enables the guaranteed soak deviation function in profiles.	o F F Off (62) o n On (63)	Off	<i>Instance 1</i> Map 1Map 2 2530 4350	22006	uint RWE
Bluetooth	o F F Off o n On	On	----	----	uint RWE

* These parameters/prompts are available in these menus with firmware revisions 11.0 and above.

** R: Read, W: Write, E: EEPROM, S: User Set

Setup Page

Parameter Name Description	Range	Default	Modbus Relative Address	Parameter ID	Data Type and Access **
Global Guaranteed Soak Deviation 1 Set the value of the deviation band that will be used in all profile step types. The process value must enter the deviation band before the step can proceed.	0.0 to 9,999.000°F or units 0.0 to 5,555.000°C	10.0°F or units 6.0°C	Instance 1 Map 1Map 2 2532 4352	22007	float RWE
Global Source Instance A Set the digital source for Wait for Event 1 in profile.	5 to 6	5	Instance 1 Map 1Map 2 - - - - 4390	22060	uint RWES
Global Source Instance B Set the digital source for Wait for Event 2 in profile.	5 to 6	5	Instance 1 Map 1Map 2 - - - - 4392	22061	uint RWES
Global Power Off Time If profile is running and power is lost, profile will resume where it left off provided time set has not expired prior to power restoration.	0 to 9999 seconds	0	Instance 1 Map 1Map 2 - - - - 4484	22073	uint RWE
* Available with PM4, PM8 and PM9 models only					
* These parameters/prompts are available in these menus with firmware revisions 11.0 and above. ** R: Read, W: Write, E: EEPROM, S: User Set					

Setup Page

Parameter Name Description	Range	Default	Modbus Relative Address	Parameter ID	Data Type and Access **
Global Synchronized Variable Time Base Used to acquire tighter accuracy when running a profile. A setting of +0.01 would equate to approximately +9 seconds/day (faster) where a setting of -0.01 would equate to approximately -9 seconds/day (slower).	-2 to 2 %	0.00	- - - -	- - - -	float RWE
Global Communications LED Action Turns comms LED on or off for selected comms ports.	On 1 Comm port 1 (1189) Off (62)	Comm port 1	Instance 1 Map 1Map 2 1856 2326	3014	uint RWES
Global Zone Turns Zone LED on or off based on selection.	Off (62) On (63)	On	Instance 1 Map 1Map 2 - - - - 2350	3026	uint RWES
Global Channel Turns Channel LED on or off based on selection.	Off (62) On (63)	On	Instance 1 Map 1Map 2 - - - - 2352	3027	uint RWES
Global Display Pairs Defines the number of Display Pairs.	1 to 10	2	Instance 1 Map 1Map 2 - - - - 2354	3028	uint RWES
Global Display Time Time delay in toggling between Display Pairs.	0 to 60	0	Instance 1 Map 1Map 2 - - - - 2356	3029	uint RWES
Global Save Settings As Save all of this controller's settings to the selected set.	Set 1 User Set 1 (101) Set 2 User Set 2 (102) None (61)	None	Instance 1 Map 1Map 2 26 26	1014	uint RWE

* These parameters/prompts are available in these menus with firmware revisions 11.0 and above.

** R: Read, W: Write, E: EEPROM, S: User Set

Setup Page

Parameter Name Description	Range	Default	Modbus Relative Address	Parameter ID	Data Type and Access **
Global Restore Settings From Replace all of this controller's settings with another set.	<i>Fcty</i> Factory (31) <i>none</i> None (61) <i>Set 1</i> User Set 1 (101) <i>Set 2</i> User Set 2 (102)	None	<i>Instance 1</i> Map 1Map 2 24 24	1013	uint RWE
Comms Set Communications Menu					
Communications Protocol Set the protocol of this controller to the protocol that this network is using.	<i>Std</i> Standard Bus (1286) <i>Mod</i> Modbus RTU (1057)	Modbus	<i>Instance 1</i> Map 1Map 2 2492 2972	17009	uint RWE
Standard Bus					
Communications Standard Bus Address Set the network address of this controller. Each device on the network must have a unique address. The Zone Display on the front panel will display this number.	1 to 16	1	<i>Instance 1</i> Map 1Map 2 2480 2960	17001	uint RWE
Modbus RTU					
Communications Modbus Address Set the network address of this controller. Each device on the network must have a unique address.	1 to 247	1	<i>Instance 1</i> Map 1Map 2 2482 2962	17007	uint RWE
Communications Baud Rate Set the speed of this controller's communications to match the speed of the Modbus serial network.	<i>9600</i> 9,600 (188) <i>192</i> 19,200 (189) <i>384</i> 38,400 (190)	9,600	<i>Instance 1</i> Map 1Map 2 2484 2964	17002	uint RWE
* These parameters/prompts are available in these menus with firmware revisions 11.0 and above. ** R: Read, W: Write, E: EEPROM, S: User Set					

Setup Page

Parameter Name Description	Range	Default	Modbus Relative Address	Parameter ID	Data Type and Access **
<p>Communications Parity Set the parity of this controller to match the parity of the Modbus serial network.</p>	<p><i>nonE</i> None (61) <i>EuEn</i> Even (191) <i>odd</i> Odd (192)</p>	None	<p>Instance 1 Map 1Map 2 2486 2966</p>	17003	uint RWE
<p>Communications Display Units Select whether this communications channel will display in Celsius or Fahrenheit. Note: Applies to Modbus only.</p>	<p><i>F</i> Fahrenheit (30) <i>C</i> Celsius (15)</p>	F	<p>Instance 1 Map 1Map 2 2490 2970</p> <p>Instance 2 Map 1Map 2 2510 2990</p>	17050	uint RWE
<p>Communications Modbus Word Order Select the word order of the two 16-bit words in the floating-point values.</p>	<p><i>L o h ,</i> Low-High (1331) <i>h , L o</i> High-Low (1330)</p>	Low-High	<p>Instance 1 Map 1Map 2 2488 2968</p>	17043	uint RWE
<p>Communications Data Map If set to 1 the control will use PM legacy mapping. If set to 2 the control will use new mapping to accommodate new functions.</p>	1 to 2	----	----	17059	uint RWE

7

Chapter 7: Profiling Page

Navigating the Profiling Page

Note:

Some of these menus and parameters may not appear, depending on the controller's options. See model number information in the Appendix for more information. If there is only one instance of a menu, no submenus will appear.

Profile Setup

First, consider some foundational profile setup features that once configured, will apply to all configured profiles. The screen shot below (Configurator software) graphically shows the settings (shaded green) that will apply to all profiles; e.g., if Guaranteed Soak is not enabled here this feature will not be available in any individual profile configuration.

Some of those features that apply to all profiles are listed below with a brief description of their function.

- **Ramping Type** (Time or Rate) which changes the profile set point based on a set interval of time or set rate.
- **Profile Type** (Set Point or Process) determines whether a step (any step changing the set point) of a profile will begin by using the process value (Process) or the last closed-loop set point (Set Point).

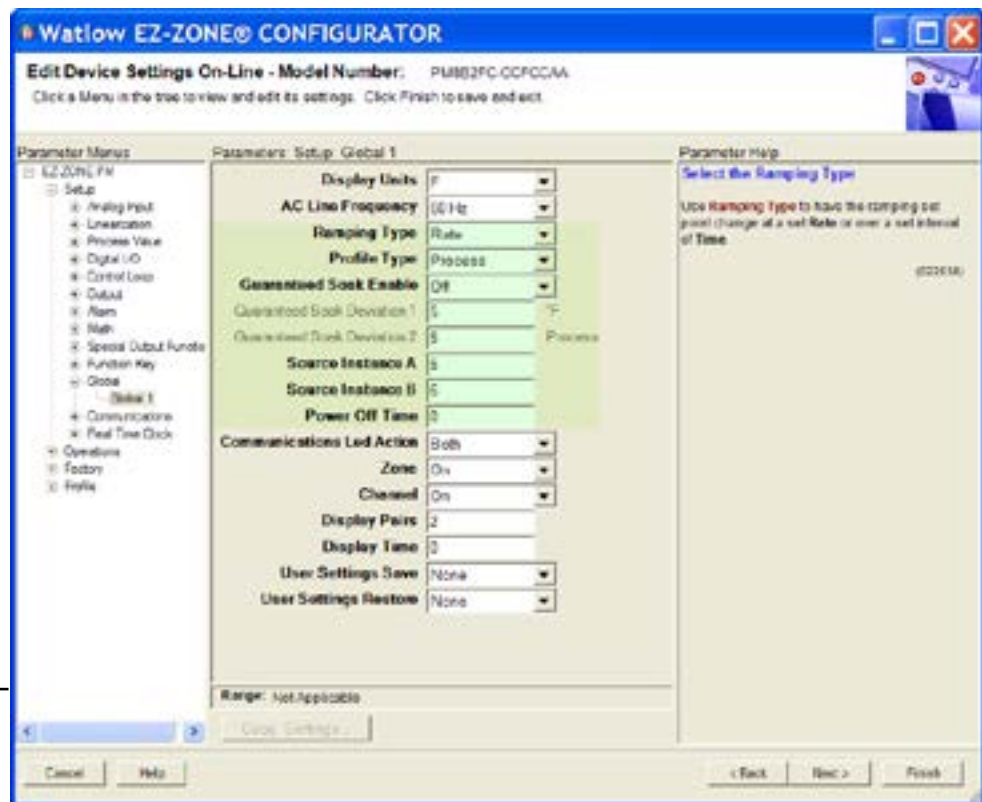













- **Guaranteed Soak** Enable, when set to on makes this feature available in all profiles. If Guaranteed Soak Enable is on, use Guaranteed Soak Deviation 1 to set the value for the corresponding loop. Set the deviation or band above or below the working set point where this condition must be met before the profile can proceed.

Note:

Changes made to profile parameters in the Profiling Pages will be saved and take effect on the next pass through the step. Changes made in the Profile Status page effect the current step being executed and do not update the step setting in the profiling page. Changing profiles should only be changed by knowledgeable personnel and with caution.

Once these global profile features are configured, the next step will require navigation to the Profiling Page. Here, each desired ramp and soak profile will be configured.

To navigate to the Profile Page from the front panel, follow the steps below:

1. From the Home Page, press and hold the Advance Key  for approximately five seconds. The profile prompt *Pr o F* will appear in the green display and the profile number (e.g. *P 1*) appears in the red display.
2. Press the Up  or Down  key to change to another profile (1 to 4).
3. Press the Advance Key  to move to the selected profiles first step.
4. Press the Up  or Down  keys to move through and select the step type.
5. Press the Advance Key  to move through the selected step settings.
6. Press the Up  or Down  keys to change the steps settings.
7. Press the Infinity Key  at any time to return to the step number prompt.
8. Press the Infinity Key  again to return to the profile number prompt.
9. From any point press and hold the Infinity Key  for two seconds to return to the Home Page.

If using Configurator software, simply click on the plus sign next to Profiles in the left hand column, as shown in the screen shot below.

Notice in the screen shot to the right some fields or parameters are not selectable (grayed out) based on the Step Type that is selected.

Starting a Profile

There are several ways to start a profile. Some of the examples that follow requires that certain optional hardware be available on the control. If you are uncertain as to how your control is equipped, compare the part number of your control to the "Ordering Information" page found in the Appendix of this Users Guide.

Two Ways to start a profile:

- Digital Input
- Profile Request

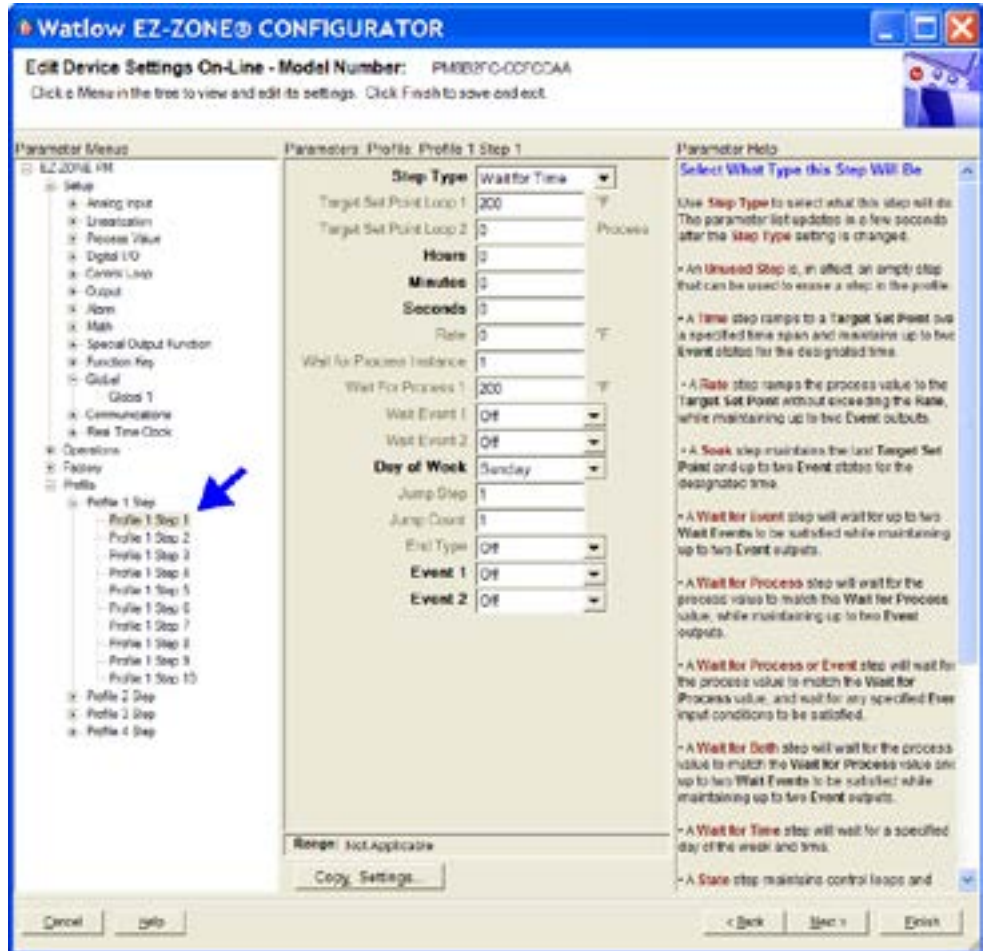

Configuring a Digital Input to Start and Stop a Profile

1. Navigate to the Setup Page and then the Digital I/O menu. From the Home Page, press and hold the **▲** or Down **▼** key for approximately six seconds where the red display will show **A I** and the green display will show **SEt**.
2. Press the Up **▲** or Down **▼** key to navigate to the Digital I/O menu. Red display will show **d io** and the green display will show **SEt**.
3. Press the Advance Key **⊕** where the first available digital instance will be displayed in the red display.
4. Press the Up **▲** or Down **▼** key to select the input of choice.
5. Press the Advance Key **⊕** to select the direction (input or output). In this example, select Dry Contact **iCon**.
6. Select the level (high or low) that will activate the function by pressing the Advance Key **⊕** where the red display will show **h iGh** and the green display will show **LEu**.
7. Press the Up **▲** or Down **▼** keys to select the level that will start the profile (high = closed or low = open).
8. Press the Advance Key **⊕** to select the function **Fn**. In this example, select Profile Start / Stop **PStS**.
9. Press the Advance Key **⊕** to select the function instance (Profile to start).
10. Return to the Home Page by pressing and holding the Infinity Key **∞** for approximately three seconds.

Starting a Profile from the Operations Page

1. Navigate to the Operations Page and then the Profile Status menu. From the Home Page, press and hold the **▲** or Down **▼** key for approximately three seconds where the red display will show **A I** and the green display will show **oPEr**.
2. Press the Up **▲** or Down **▼** key to navigate to the Profile Status **PStA** menu.
3. Press the Advance Key **⊕** to enter this menu. The red display will show **I** and the green display will show **PStEr**.
4. Press the Up **▲** or Down **▼** keys to select the Profile or Step to start. In this example select 1.
5. Press the Advance Key **⊕** to select the Profile Action Request. The red display will show **nonE** and the green display will show **PACr**.
6. Press the Up **▲** or Down **▼** keys to select the Profile start. The red display will show **P_r oF** and the green display will show **PACr**.

Note:

As soon as the Green Advance Key **⊕** is pressed (step 7 below) the designated Profile or Step (as determined in step 4 above) will start.



7. Press the Advance Key **⊕** to select whether Event 1 will be on or off. The red display will show **oFF** and the green display will show **Ent 1**.

Note:

This setting will temporarily override the profile configuration.



8. Press the Up **▲** or Down **▼** keys to select whether Event 1 will be on or off. This will immediately drive the Event to the specified state regardless of the Profile configuration.
9. Press the Advance Key **⊕** to select whether Event 2 will be on or off. The red display will

show *oFF* and the green display will show *Ent2*.











10. Press the Up  or Down  keys to select whether Event 2 will be on or off. This will immediately drive the Event to the specified state regardless of the Profile configuration.

Note:







The event state will be as left when the profile ended and may be toggled at the profile status menu.

11. Press the Advance Key  to see the current Jump Count. The red display will show *0* and the green display will show *JC*.
12. Return to the Home Page by pressing and holding the Infinity Key  for approximately three seconds.



Ending a Profile from the Operations Page

1. Navigate to the Operations Page and then the Profile Status menu. From the Home Page, press and hold the Up  or Down  key for approximately three seconds where the red display will show *Pr* and the green display will show *oPER*.
2. Press the Up  or Down  key to navigate to the Profile Status *PStR* menu.
3. Press the Advance Key  to enter this menu. The red display will show *!* and the green display will show *PStR*.
4. Press the Advance Key  to select the Profile Action Request. The red display will show *nonE* and the green display will show *PACr*.
6. Press the Up  or Down  keys to select the End. The red display will show *End* and the green display will show *PACr*.
7. Press the Advance Key  to end the Profile.
8. Return to the Home Page by pressing and holding the Infinity Key  for approximately three seconds.

Starting a Profile from the Home Page

1. When at the Home Page, press the Advance Key  to locate Profile Start and select the file or step number to start. The red display will show *!* and the green display will show *PStI*.
2. Press the Up  or Down  key to choose the file or step number.
3. Press the Advance Key  to select the Profile Action Request. The red display will show *nonE* and the green display will show *PACI*.
4. Press the Up  or Down  keys to select the Profile Start. The red display will show *Pr oF* and the green display will show *PACI*.
5. Press the Infinity Key to return Home. The Profile will Start

Ending a Profile from the Home Page

1. Press the Advance Key  to select the Profile Action Request. The red display will show *nonE* and the green display will show *PACI*.
2. Press the Up  or Down  keys to select the End. The red display will show *End* and the green display will show *PACI*.
3. Press the Infinity Key to return Home. The Profile will End.

Profiling Parameters

P I

Pr o F Profile (1 to 4)

I

P I Profile [1 to 4] Step (1 to 40)

St Y P Step Type

t.S P I Target Set Point Loop 1

h o U r Hours

M i n Minutes

S E C Seconds

r A T E Rate

W D P 1 Wait For Process 1

W D E 1 Wait For Event 1

W D E 2 Wait for Event 2

J S Jump Step

J C Jump Count

E n d End Type

E n t 1 Event 1

E n t 2 Event 2

Profiling Page

Display	Parameter Name Description	Range	Default	Modbus Relative Address	Parameter ID	Data Type and Access **
P1 Prof Profiling Menu						
P1 to P4	Profile [1 to 4] Step Select a step to edit or view.	1 to 10 [profile 1] 11 to 20 [profile 2] 21 to 30 [profile 3] 31 to 40 [profile 4]		----	----	----
StYP S.typ	Step Type Select a step type. Note: Prior to selecting the Step Type consider whether or not profiles will be based on time or rate of change. By default, profiles are configured for Time t . Therefore, Rate will not be available here. If it is desired to base profiles on rate of change, navigate to the Setup Page and then the Global Menu where Ramping Type can be changed from Time to Rate.	US t P Unused Step (50) SoRH Soak (87) W t E Wait For Event (144) W t Pr Wait For Process (209) W t Bo Wait For Both (210) JL Jump (116) End End (27) t , Time (143) rAtE Rate (81)	Unused	Instance 1 Map 1 Map 2 2570 4500 Offset to next instance (Map 1 equals +50, Map 2 equals +100)	21001	uint RWE
t.SP1 t.SP1	Step Type Parameters Target Set Point Loop 1 When Step Type is Time or Rate, enter the closed loop set point for loop 1 to ramp to for this step.	-1,999.000 to 9,999.000°F or units -1,128 to 5,537.000°C	0.0°F or units -18°C	Instance 1 Map 1 Map 2 2572 4502 Offset to next instance (Map 1 equals +50, Map 2 equals +100)	21002	float RWE
hoUr hoUr	Step Type Parameters Hours Select the hours (plus Minutes and Seconds) for a timed step.	0 to 9999	0	Instance 1 Map 1 Map 2 2574 4504 Offset to next instance (Map 1 equals +50, Map 2 equals +100)	21003	uint RWE
Note: Some values will be rounded off to fit in the four-character display. Full values can be read with other interfaces. ** R: Read, W: Write, E: EEPROM, S: User Set						

Profiling Page

Display	Parameter Name Description	Range	Default	Modbus Relative Address	Parameter ID	Data Type and Access **
Min	Step Type Parameters Minutes When Step Type is Time, Soak, or Wait For Time enter Minutes (plus Hours and Seconds) for this step.	0 to 59	0	Instance 1 Map 1 Map 2 2576 4506 Offset to next instance (Map 1 equals +50, Map 2 equals +100)	21004	uint RWE
SEC	Step Type Parameters Seconds When Step Type is Time, Soak, or Wait For Time enter Seconds (plus Hours and Minutes) for this step.	0 to 59	0	Instance 1 Map 1 Map 2 2578 4508 Offset to next instance (Map 1 equals +50, Map 2 equals +100)	21005	uint RWE
rAtE	Step Type Parameters Rate When Step Type is Rate, enter the rate for ramping in degrees or units per minute.	0 to 9,999.000°F or units per minute 0 to 5,555.000°C per minute	0.0	Instance 1 Map 1 Map 2 2580 4510 Offset to next instance (Map 1 equals +50, Map 2 equals +100)	21006	float RWE
W.P1	Step Type Parameters Wait For Process 1 When Step Type is Wait for Process or Wait For Both, enter wait for process value on analog input specified by Wait For Process Instance before proceeding in profile.	-1,999.000 to 9,999.000°F or units -1,128.000 to 5,537.000°C	0.0°F or units -18.0°C	Instance 1 Map 1 Map 2 2590 4520 Offset to next instance (Map 1 equals +50, Map 2 equals +100)	21011	float RWE

Note:

Some values will be rounded off to fit in the four-character display. Full values can be read with other interfaces.

** R: Read, W: Write, E: EEPROM, S: User Set

Profiling Page

Display	Parameter Name Description	Range	Default	Modbus Relative Address	Parameter ID	Data Type and Access **
WE.1 WE.1	<p>Step Type Parameters</p> <p>Wait Event 1 When Step Type is Wait for Event or Wait For Both, select the event state that must be satisfied during this step.</p> <p>Note: Wait Event 1 can be mapped to any available digital input (5 - 12). Navigate to the Setup Page under the Global Menu to find and modify Source Instance A S.1A (Event 1) and Source Instance B S.1B (Event 2).</p>	<p>OFF Off (62) ON On (63) none None (61)</p>	Off	<p>Instance 1 Map 1 Map 2 2586 4516</p> <p>Offset to next instance (Map 1 equals +50, Map 2 equals +100)</p>	21009	uint RWE
WE.2 WE.2	<p>Step Type Parameters</p> <p>Wait Event 2 When Step Type is Wait for Event or Wait For Both, select the event state that must be satisfied during this step.</p> <p>Note: Wait Event 2 can be mapped to any available digital input (5 - 6). Navigate to the Setup Page under the Global Menu to find and modify Source Instance A S.1A (Event 1) and Source Instance B S.1B (Event 2).</p>	<p>OFF Off (62) ON On (63) none None (61)</p>	Off	<p>Instance 1 Map 1 Map 2 2588 4518</p> <p>Offset to next instance (Map 1 equals +50, Map 2 equals +100)</p>	21010	uint RWE
JS JS	<p>Step Type Parameters</p> <p>Jump Step When Step Type is Jump, this specifies which step to jump back to. Jump Step must be a lower step number than the current step number.</p>	1 to 40	0	<p>Instance 1 Map 1 Map 2 2592 4522</p> <p>Offset to next instance (Map 1 equals +50, Map 2 equals +100)</p>	21012	uint RWE

Note:

Some values will be rounded off to fit in the four-character display. Full values can be read with other interfaces.

** R: Read, W: Write, E: EEPROM, S: User Set

Profiling Page

Display	Parameter Name Description	Range	Default	Modbus Relative Address	Parameter ID	Data Type and Access **
JC JC	Step Type Parameters Jump Count When Step Type is Jump, this specifies the number of jumps to repeat. A value of 0 creates an infinite loop. Loops can be nested four deep.	0 to 9,999	0	Instance 1 Map 1 Map 2 2594 4524 Offset to next instance (Map 1 equals +50, Map 2 equals +100)	21013	uint RWE
End End	Step Type Parameters End Type When Step Type is End, this specifies what the controller will do when this profile ends.	oFF Control Mode set to Off (62) Hold Hold last closed-loop set point in the profile (47) USER User, reverts to previous set point (100)	Off	Instance 1 Map 1 Map 2 2596 4526 Offset to next instance (Map 1 equals +50, Map 2 equals +100)	21014	uint RWE
Ent 1 Ent1	Step Type Parameters Event 1 When Step Type is not Unused Step, select whether Event Output 1 or 2 is on or off during this step.	oFF Off (62) on On (63)	Off	Instance 1 Map 1 Map 2 2582 4512 Offset to next instance (Map 1 equals +50, Map 2 equals +100)	21007	uint RWE
Ent 2 Ent2	Step Type Parameters Event 2 When Step Type is not Unused Step, select whether Event Output 1 or 2 is on or off during this step.	oFF Off (62) on On (63)	Off	Instance 1 Map 1 Map 2 2584 4514 Offset to next instance (Map 1 equals +50, Map 2 equals +100)	21008	uint RWE

Note:

Some values will be rounded off to fit in the four-character display. Full values can be read with other interfaces.

** R: Read, W: Write, E: EEPROM, S: User Set













Display	Step Type Description	Parameters in Step Type
UStP UStP	Step Types Unused Step This is an empty step that can be used to plan for future steps to be inserted or temporarily deactivate a step in a profile. Change step type back when the step should be active again.	- - - -
ti	Step Types Time If Ramping Type found in the Global Menu of the Setup Page is set for Time, the control loop will follow set point over the specified time. If two loops of control are present then they will both follow independent set points over the specified time. The state of up to 2 event outputs may be set or maintained.	tSP1 Target Set Point Loop 1 hour Hours min Minutes SEC Seconds Ent1 Event 1 Ent2 Event 2
rAtE rAtE	Step Types Rate If Ramping Type found in the Global Menu of the Setup Page is set for Rate, specify the rate of change in degrees or units per minute. The state of up to 2 event outputs may be set or maintained.	tSP1 Target Set Point Loop 1 rAtE Rate Ent1 Event 1 Ent2 Event 2
SoAh SoAh	Step Types Soak A Soak Step maintains the last Target Set Points for the designated time. The state of up to 2 event outputs may be set or maintained.	hour Hours min Minutes SEC Seconds Ent1 Event 1 Ent2 Event 2
WE W.E	Step Types Wait For Event A Wait for Event Step will wait for the two Wait for Event states (1 to 2) to match the specified state. The state of up to 2 event outputs may be set or maintained.	WE1 Wait Event 1 WE2 Wait Event 2 Ent1 Event 1 Ent2 Event 2
WPr W.Pr	Step Types Wait For Process A Wait for Process Step will wait for Process Value 1 or 2 to match the Wait for Process Value. The state of up to 2 event outputs may be set or maintained.	WPr Wait for Process Instance WPr1 Wait for Process 1 Value Ent1 Event 1 Ent2 Event 2
Wbo W.bo	Step Types Wait For Both A Wait For Process and Event Step will wait for Process Value 1 or 2 to match the Wait for Process 1 value, and/or the two Wait Event states to match the specified state. The state of up to 2 event outputs may be set or maintained.	WPr Wait for Process Instance WPr1 Wait for Process 1 Value WE1 Wait Event 1 WE2 Wait Event 2 Ent1 Event 1 Ent2 Event 2
JL JL	Step Types Jump A Jump step will repeat previous steps a number of times designated in Jump Count. Jumps can be nested up to four deep. The state of up to 2 event outputs may be set or maintained.	JS Jump Step JC Jump Count Ent1 Event 1 Ent2 Event 2
End End	Step Types End An End Step will end the profile and set the control modes and set points to match the End Type. The state of up to 2 event outputs may be set or maintained. The event outputs will not be set off unless specifically stated in this step. If a profile does not have an End Step, the profile continues until step 40, then stops and maintains the last set points and control modes.	End End Type Ent1 Event 1 Ent2 Event 2

8

Chapter 8: Factory Page

Navigating the Factory Page

To navigate to the Factory Page follow the steps below:

1. From the Home Page, press and hold both the Advance  and Infinity  keys for six seconds.
2. Press the Up  or Down  key to view available menus.
3. Press the Advance Key  to enter the menu of choice.
4. If a submenu exists (more than one instance), press the Up  or Down  key to select and then press the Advance Key  to enter.
5. Press the Up  or Down  key to move through available menu prompts.
6. Press the Infinity Key  to move backwards through the levels: parameter to submenu, submenu to menu, menu to Home Page.
7. Press and hold the Infinity Key  for two seconds to return to the Home Page.

On the following pages, top level menus are identified with a yellow background color.

Note:

Some of these menus and parameters may not appear, depending on the controller's options. See model number information in the Appendix for more information. If there is only one instance of a menu, no submenus will appear.

Note:

Some of the listed parameters may not be visible. Parameter visibility is dependent upon controller part number.

CUST FCTY Custom Setup Menu

- 1
CUST Custom Setup (1 to 20)
- PAR Parameter
- IID Instance ID

LoC FCTY Security Setting Menu

- LoCo Operations Page
- LoCP Profiling Page
- PASE Password Enabled
- rLoC Read Lock
- SLoC Write Security
- LoCL Locked Access Level
- roLL Rolling Password
- PASu User Password

PASr Administrator Password

ULoC FCTY Security Setting Menu

- CoDE Public Key
- PASS Password

dIAG FCTY Diagnostics Menu

- Pn Part Number
- rEu Software Revision
- SbLd Software Build Number
- Sn Serial Number
- dATE Date of Manufacture

CAL FCTY Calibration Menu

- 1
CAL Calibration
- PAu Electrical Measurement
- ELio Electrical Input Offset
- ELiS Electrical Input Slope
- ELoo Electrical Output Offset
- ELoS Electrical Output Slope
- Pn Part Number
- CoDE Code

Factory Page

Display	Parameter Name Description	Range	Default	Modbus Relative Address	Parameter ID	Data Type and Access **
<div style="display: flex; justify-content: space-around;"> CUST Fcty Custom </div>						
PAR Par	Custom Parameter 1 to 20 Select the parameters that will appear in the Home Page. The Parameter 1 value will appear in the red display of the Home Page. It cannot be changed with the Up and Down Keys in the Home Page. The Parameter 2 value will appear in the green display in the Home Page. It can be changed with the Up and Down Keys, if the parameter is a writable one. Scroll through the other Home Page parameters with the Advance Key  . Note: Display Pairs affect the pairing of custom parameters on the Home page. For more information on Display Pairs see the section in this guide entitled "Modifying the Display Pairs".	<div style="font-family: monospace; font-size: small;"> none None Pro Process .CA Calibration Offset .F Display Units USrr Restore Settings From RLo Low Set Point Rhi High Set Point Rhy Hysteresis SetPt Set Point AC.Pv Active Process Value AC.SP Active Set Point oP Manual Power Aut Autotune .C.M Control Mode hPr Heat Power .C.Pr Cool Power t i Time Integral td Time Derivative db Dead Band hPb Heat Proportional Band hhy On/Off Heat Hysteresis .C.Pb Cool Proportional Band .Chy On/Off Cool Hysteresis .rrt Ramp Rate t.tUn TRU-TUNE+® Enable .idle Idle Set Point .P.St Profile Start .P.AC Profile Action Request .StP Current Step .StYP Step Type .t.SP i Target Set Point .hou Hours .M.in Minutes .SEC Seconds .95d i Guaranteed Soak Deviation 1 .Ent 1 Event 1 .Ent 2 Event 2 .JC Jump Count Remaining .CUST Custom Menu </div>	See: Home Page	- - - -	14005	uint RWES
** R: Read, W: Write, E: EEPROM, S: User Set						

Factory Page

Display	Parameter Name Description	Range	Default	Modbus Relative Address	Parameter ID	Data Type and Access **
iid	Custom (1 to 20) Instance ID Select which instance of the parameter will be selected.	1 to 4		----	14003	uint RWES
LoC Fcty Lock Menu						
LoCo	Security Setting Operations Page Change the security level of the Operations Page.	1 to 3	2	Instance 1 Map 1 Map 2 1832 2302	3002	uint RWE
LoCP	Security Setting Profiling Page Change the security level of the Profiling Page.	1 to 3	3	Instance 1 Map 1 Map 2 1844 2314	3008	uint RWE
LoCP	Security Setting Password Enable Set to On to require a password for menu changes.	oFF Off oN On	Off	----	3009	uint RWE
rLoC	Security Setting Read Lock Set the read security clearance level. The user can access the selected level and all lower levels. If the Set Lockout Security level is higher than the Read Lockout Security, the Read Lockout Security level takes priority.	1 to 5	5	Instance 1 Map 1Map 2 1848 2318	3010	uint RWE

** R: Read, W: Write, E: EEPROM, S: User Set

Factory Page

Display	Parameter Name Description	Range	Default	Modbus Relative Address	Parameter ID	Data Type and Access **
SLoC SLoC	Security Setting Write Security Set the write security clearance level. The user can access the selected level and all lower levels. If the Set Lockout Security level is higher than the Read Lockout Security, the Read Lockout Security level takes priority.	0 to 5	5	<i>Instance 1</i> Map 1 Map 2 1844 2314	3011	uint RWE
LoC.L LoC.L	Security Setting Locked Access Level Determines user level menu visibility when Password Enable is set to on. See Features section under Password Security.	1 to 5	5	-----	3016	uint RWE
roLL roLL	Security Setting Rolling Password When power is cycled a new Public Key will be displayed and User Password changes.	oFF Off oN On	Off	-----	3019	uint RWE
PAS.u PAS.u	Security Setting User Password Used to acquire access to menus made available through the Locked Access Level setting.	10 to 999	63	-----	3017	uint RWE

** R: Read, W: Write, E: EEPROM, S: User Set

Factory Page

Display	Parameter Name Description	Range	Default	Modbus Relative Address	Parameter ID	Data Type and Access **
<i>PAS.A</i> PAS.A	Security Setting Administrator Password Used to acquire full access to all menus including disabling or changing passwords.	10 to 999	156	- - - -	3018	uint RWE
<i>ULoC</i> <i>FCEY</i> Unlock Menu						
<i>CodE</i> CodE	Security Setting Public Key If Rolling Password turned on, generates a random number when power is cycled. If Rolling Password is off fixed number will be displayed. The key can be used to gain access when password is not known.	Customer Specific	0	- - - -	3020	uint R
<i>PASS</i> PASS	Security Setting Password Enter the User or Administrator password to gain access. After valid password is supplied exit this menu and re-enter the Security Menu via the Factory Page.	-1999 to 9999	0	- - - -	3022	int RW
** R: Read, W: Write, E: EEPROM, S: User Set						

Factory Page

Display	Parameter Name Description	Range	Default	Modbus Relative Address	Parameter ID	Data Type and Access **
<div style="display: flex; justify-content: space-between; align-items: center;"> d .R9 FCT4 </div> <h3 style="margin-top: 5px;">Diagnostics Menu</h3>						
Pn Pn	Diagnostics Part Number Display this controller's part number.	15 characters	----	----	1009	string R
rEu rEu	Diagnostics Software Revision Display this controller's firmware revision number.	1 to 10	----	Instance 1 Map 1 Map 2 4 4	1003	string R
S.bLd S.bLd	Diagnostics Software Build Number Display the firmware build number.	0 to 2,147,483,647	----	Instance 1 Map 1 Map 2 8 8	1005	dint R
Sn Sn	Diagnostics Serial Number Display the serial number.	0 to 2,147,483,647	----	Instance 1 Map 1 Map 2 12 12	1032	string R
dAtE dAtE	Diagnostics Date of Manufacture Display the date code (YYWW). Where YY = year and WW= week.	0 to 2,147,483,647	----	Instance 1 Map 1Map 2 14 14	1008	dint R
No Display	Diagnostics Hardware ID Display the Hardware ID.	0 to 2,147,483,647	----	Instance 1 Map 1Map 2 0 0	1001	dint R
** R: Read, W: Write, E: EEPROM, S: User Set						

Factory Page

Display	Parameter Name Description	Range	Default	Modbus Relative Address	Parameter ID	Data Type and Access **
No Display	Diagnostics Firmware ID Display the Firmware ID.	0 to 2,147,483,647	- - - -	Instance 1 Map 1 Map 2 2 2	1002	dint R
CAL FCTY Calibration Menu						
mv Mv	Calibration Electrical Mea- surement Read the raw electrical value for this input in the units cor- responding to the Sensor Type (Setup Page, Analog Input Menu) setting.	-3.4e38 to 3.4e38		Instance 1 Map 1 Map 2 400 400 Instance 2 Map 1 Map 2 480 490	4021	float R
EL 1.0 ELi.o	Calibration Electrical Input Offset Change this val- ue to calibrate the low end of the input range.	-1,999.000 to 9,999.000	0.0	Instance 1 Map 1 Map 2 378 378 Instance 2 Map 1 Map 2 458 468	4010	float RWES
EL 1.5 ELi.S	Calibration Electrical Input Slope Adjust this value to calibrate the slope of the in- put value.	-1,999.000 to 9,999.000	1.0	Instance 1 Map 1 Map 2 380 380 Instance 2 Map 1 Map 2 460 470	4011	float RWES
** R: Read, W: Write, E: EEPROM, S: User Set						

Factory Page

Display	Parameter Name Description	Range	Default	Modbus Relative Address	Parameter ID	Data Type and Access **
<i>ELo.o</i> ELo.o	Calibration Electrical Output Offset Change this value to calibrate the low end of the output range.	-1,999.000 to 9,999.000	0.0	Instance 1 Map 1 Map 2 728 848 Instance 3 Map 1 Map 2 808 928	18005	float RWES
<i>ELo.S</i> ELo.S	Calibration Electrical Output Slope Adjust this value to calibrate the slope of the output value.	-1,999.000 to 9,999.000	1.0	Instance 1 Map 1 Map 2 730 850 Instance 3 Map 1 Map 2 810 930	18006	float RWES
<i>Pn</i> Pn	Calibration Part Number Displays current setting for control model number.	<i>FCTy</i> Factory <i>USEr</i> User	Factory	----	----	uint R
<i>Code</i> Code	Calibration Public Key Changes the control to User or back to original model number as shown on the side of the control.	<i>2501</i> User Settings <i>606</i> Factory model number	4999	----	----	uint RWES

** R: Read, W: Write, E: EEPROM, S: User Set

9

Chapter 9: Features

Changing PM Model Number to PM Express	112
Saving and Restoring Settings	114
Programming the Home Page	114
Tuning the PID Parameters	114
Autotune	114
Manual Tuning	115
Autotuning with TRU-TUNE+®	116
Inputs	117
Calibration Offset	117
Calibration	117
Filter Time Constant	119
Sensor Selection	119
Set Point Minimum and Maximum	119
Scale High and Scale Low	120
Range High and Range Low	120
Ten Point Linearization	120
Outputs	121
Duplex	121
Retransmitting a Process Value or Set Point	121
Cool Output Curve	122
Control Methods	122
Output Configuration	122
Auto (closed loop) and Manual (open loop) Control	122
On-Off Control	123
Proportional and (P) Control	124
Proportional and Integral (PI) Control	124
Proportional, Integral and Derivative (PID) Control	125
Dead Band	125
Variable Time Base	125
Single Set Point Ramping	126
Timer Function	127
Setting Up the Timer Function	128
Alarms	130
Process and Deviation Alarms	130
Set Points	130
Hysteresis	130
Latching	130
Silencing	131
Blocking	131

9

Chapter 9: Features (cont.)

Open Loop Detection.	131
Using Lockout and Password Security.	131
Using Lockout Method 1 (Read and Set Lock)	132
Using Lockout Method 2 (Password Enable)	134
Modbus - Using Programmable Memory Blocks.	135
Software Configuration.	136
Using PM3 LEGACY™ PID Configurator Software	136

Changing PM Model Number to PM Express



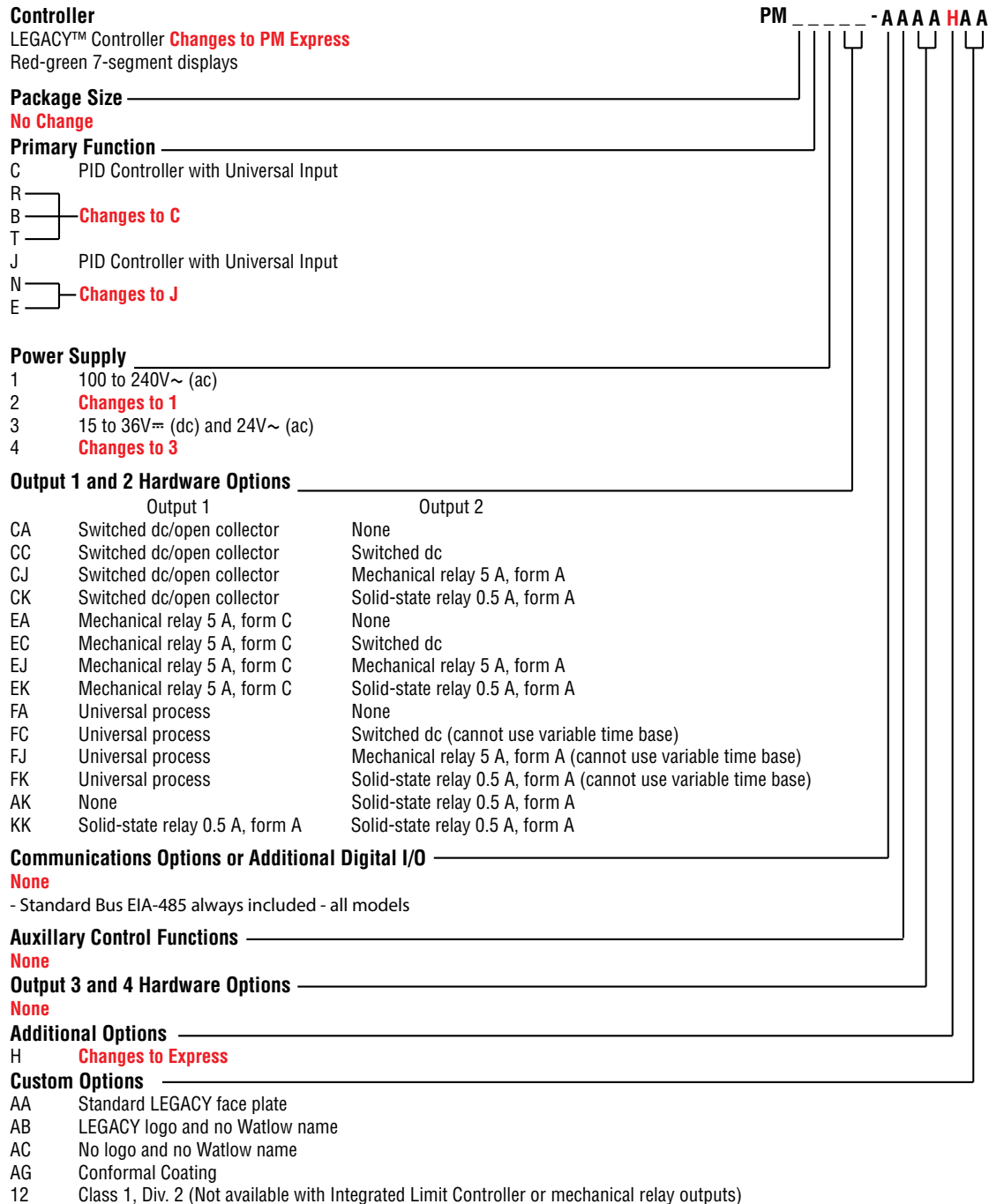

PM3 LEGACY™ PID PM firmware revisions of 13 and above allow the user to switch between a PM control to a PM Express. Switching to a PM Express eliminates the complexity of the advanced PM control by allowing the user to operate with a simplified menu structure.

Note:

When switching from an control to an Express version, optional PM hardware (even though installed) and firmware features not available in a PM Express will no longer work. To see exactly what is impacted by this change, compare the chart below to the ordering information page in this document.



How to Change the Controller Model Number

1. Enter Factory Page **FCLY**, Calibration Menu **CAL** via front panel by pressing the Infinity  or Reset Key and the Advance Key  together or using PM3 LEGACY™ PID Configurator software.
2. Once there, use the Advance Key  to navigate to the Part Number **Pn** prompt. The top display will show factory **FCLY** indicating the factory model number as shown on the decal located on the side of the control is currently in effect.
3. Push the Advance Key , Public Key **CODE** prompt will be displayed and the number **4999** in the top display.
4. Using the up or down Arrow Keys enter **2501** and push the Advance Key  to execute the change. The controller will reboot and the new controller model number is in effect. All previous settings are lost and the controller must be reprogrammed for the application. Be sure to label the controller with the new model number for future reference.

Note:





As noted above, when switching from a PM Standard to a PM Express version, optional hardware (even though installed) may no longer work. Also, all settings will be defaulted to the selected model when switched.

Note:

After switching the model number to a PM Express this document will no longer apply to the control. Click on the link that follows to acquire the latest version of the PM PID Express User's Guide. <http://www.watlow.com/en/Resources-And-Support/Technical-Library/User-Manuals>

Once there, simply enter express in the "Keyword" field to find the appropriate document.

How to Restore Original PM Factory Settings and Model Number

1. Enter Factory Page **FCLY**, Calibration Menu **CAL** via front panel by pressing the Infinity  or Reset Key and the Advance Key  together or using PM3 LEGACY™ PID Configurator software.
2. Once there, use the Advance Key  to navigate to the Part Number **Pn** prompt. The upper display will show user **USER** indicating the user's selected model number is currently in effect.
3. Push the Advance Key , where the Public Key **CODE** prompt will appear in the lower display and the number **4999** in the upper display.
4. Using the up or down arrow keys enter **606** and push the Advance Key  to execute the change. The controller will reboot and the new controller model number is in effect. All previous settings are lost and the controller must be reprogrammed for the application. Be sure to label the controller with the new model number for future reference.

Note:

When switching from a PM Express back to the original model number all original optional hardware will again be enabled for use (assuming all original hardware is still installed). Also, when executing this step the control will be factory defaulted back to the original model number (as shown on the side of the control) at zone address 1. This User's Guide would once again apply to this control.

Saving and Restoring Settings

Recording setup and operations parameter settings for future reference is very important. If you unintentionally change these, you will need to program the correct settings back into the controller to return the equipment to operational condition.

After you program the controller and verify proper operation, select Save Settings As **U5r.5** (Setup Page, Global Menu) to save the settings into either of two files (sEt1 or sEt2) in the control memory.

Note:

Saving the settings overwrites any previously saved collection of settings. Be sure to document all the controller settings.

If the settings in the controller are altered a user can return the controller to one of three settings. If previously saved, **SEt 1** or **SEt 2** can be restored as well as the factory **FCtY** settings. Navigate to the Setup Page, Global Menu to find the Restore **U5r.r** prompt. A digital input or the Function Key can also be configured to restore parameters.

Note:

When restoring factory defaults, I/O assemblies for Modbus, DeviceNet, Profibus and Ethernet along with the zone address will be overwritten when restoring factory defaults.

Programming the Home Page

Watlow's patented user-defined menu system improves operational efficiency. The user-defined Home Page provides you with a shortcut to monitor or change the parameter values that you use most often.

You can create your own Home Page with as many as 20 of the active parameters. When a parameter normally located in the Setup Page or Operations Page is placed in the Home Page, it is accessible through both. If you change a parameter in the Home Page, it is automatically changed in its original page. If you change a parameter in its original page it is automatically changed in the Home Page.

The default parameters will automatically appear in the Home Page.

Change the list of parameters in the Home Page from the Custom Menu **CUSL** (Factory Page).

Tuning the PID Parameters

Autotune

When an autotune is performed on the PM3 LEGACY™ PID, the set point is used to calculate the tuning set point.

For example, if the active set point is 200° and Autotune Set Point **ALSP** (Operations Page, Loop Menu) is set to 90 percent, the autotune function utilizes 180° for tuning. This is also how autotuning works in previous Watlow controllers. In addition, changing the active set point in previous controllers causes the autotune function to restart; where with the PM3 LEGACY™ PID changing the set point after an autotune has been started has no affect.

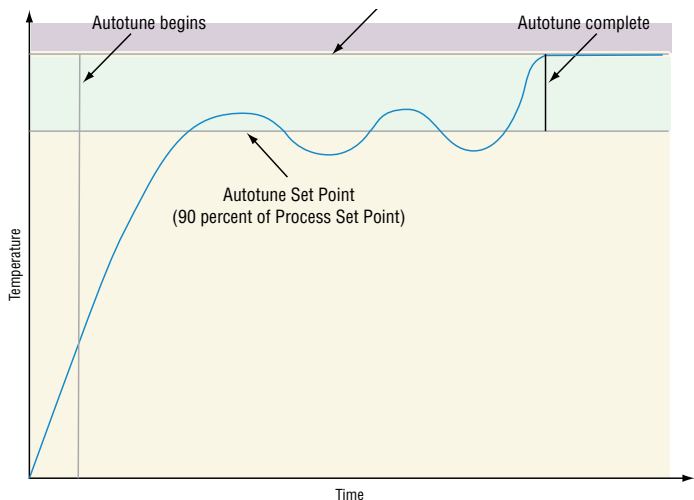

A new feature in PM3 LEGACY™ PID products will allow set point changes while the control is autotuning, this includes while running a profile or ramping. When the autotune is initially started it will use the current set point and will disregard all set point changes until the tuning process is complete. Once complete, the controller will then use the new set point. This is why it is a good idea to enter the active set point before initiating an autotune.

Autotuning calculates the optimum heating and/or cooling PID parameter settings based on the system's response. Autotuning can be enabled whether or not TUNE-TUNE+® is enabled. The PID settings generated by the autotune will be used until the autotune feature is rerun, the PID values are manually adjusted or TRU-TUNE+ is enabled.

To initiate an autotune, set Autotune Request *AUT* (Operations Page, Loop Menu) to *YES*. You should not autotune while a profile is running. If the autotune cannot be completed in 60 minutes, the autotune will time-out and the original settings will take effect.

The upper display will flash *Auto!* and the lower display will flash *Autn* while the autotuning is underway. The temperature must cross the Autotune Set Point five times to complete the autotuning process. Once complete, the controller controls

If you need to adjust the tuning procedure's aggressiveness, use Autotune Aggressiveness *AGR* (Setup Page, Loop Menu). Select Under Damped *Undr* to bring the process value to the set point quickly. Select over damped *over* to bring the process value to the set point with minimal overshoot. Select critical damped *crit* to balance a rapid response with minimal overshoot.

Manual Tuning

In some applications, the autotune process may not provide PID parameters for the process characteristics you desire. If that is the case, you may want to tune the controller manually.

1. Apply power to the controller and establish a set point typically used in your process.
2. Go to the Operations Page, Loop Menu, and set Heat Proportional Band *hPb* and/or Cool Proportional Band *CPb* to 5. Set Time Integral *ti* to 0. Set Time Derivative *td* to 0.
3. When the system stabilizes, watch the process value. If it fluctuates, increase the Heat Proportional Band or Cool Proportional Band value in 3 to 5° increments until it stabilizes, allowing time for the system to settle between adjustments.
4. When the process has stabilized, watch Heat Power *hPr* or Cool Power *CPr* (Operations Page, Monitor Menu). It should be stable $\pm 2\%$. At this point, the process temperature should also be stable, but it will have stabilized before reaching the set point. The difference between the set point and actual process value can be eliminated with Integral.
5. Start with an Integral value of 6,000 and allow 10 minutes for the process temperature to reach the set point. If it has not, reduce the setting by half and wait another 10 minutes. Continue reducing the setting by half every 10 minutes until the process value equals the set point. If the process becomes unstable, the Integral value is too small. Increase the value until the process stabilizes.
6. Increase Derivative to 0.1. Then increase the set point by 11° to 17°C. Monitor the system's approach to the set point. If the process value overshoots the set point, increase Derivative to 0.2. Increase the set point by 11° to 17°C and watch the approach to the new set point. If you increase Derivative too much, the approach to the set point will be very sluggish. Repeat as necessary until the system rises to the new set point without overshoot or sluggishness.

For additional information about autotune and PID control, see related features in this chapter.

Autotuning with TRU-TUNE+®

The TRU-TUNE+ adaptive algorithm will optimize the controller's PID values to improve control of dynamic processes. TRU-TUNE+ monitors the Process Value and adjusts the control parameters automatically to keep your process at set point during set point and load changes. When the controller is in the adaptive control mode, it determines the appropriate output signal and, over time, adjusts control parameters to optimize responsiveness and stability. The TRU-TUNE+ feature does not function for on-off control.

The preferred and quickest method for tuning a loop is to establish initial control settings and continue with the adaptive mode to fine tune the settings. Setting a controller's control mode to tune starts this two-step tuning process. (See Autotuning in this chapter.) This predictive tune determines initial, rough settings for the PID parameters. Then the loop automatically switches to the adaptive mode which fine tunes the PID parameters.

Once the Process Value has been at set point for a suitable period (about 30 minutes for a fast process to roughly two hours for a slower process) and if no further tuning of the PID parameters is desired or needed, TRU-TUNE+™ may be turned off. However, keeping the controller in the adaptive mode allows it to automatically adjust to load changes and compensate for differing control characteristics at various set points for processes that are not entirely linear. Once the PID parameters have been set by the TRU-TUNE+ adaptive algorithm, the process, if shut down for any reason, can be restarted in the adaptive control mode. Turn TRU-TUNE+ on or off with TRU-TUNE+ Enable $\underline{t.tUn}$ (Setup Page, Loop Menu).

Use TRU-TUNE+ Band $\underline{t.bnd}$ (Setup Page, Loop Menu) to set the range above and below the set point in which adaptive tuning will be active. Adjust this parameter only in the unlikely event that the controller is unable to stabilize at the set point with TRU-TUNE+ Band set to auto (0). This may occur with very fast processes. In that case, set TRU-TUNE+ Band to a large value, such as 100.

Use TRU-TUNE+ Gain $\underline{t.gn}$ (Setup Page, Loop Menu) to adjust the responsiveness of the adaptive tuning calculations. Six settings range from 1, with the most aggressive response and most potential overshoot (highest gain), to 6, with the least aggressive response and least potential for overshoot (lowest gain). The default setting, 3, is recommended for loops with thermocouple feedback and moderate response and overshoot potential.

Before Tuning

Before autotuning, the controller hardware must be installed correctly, and these basic configuration parameters must be set:

- Sensor Type \underline{SEn} (Setup Page, Analog Input Menu), and scaling, if required;
- Function \underline{Fn} (Setup Page, Output Menu) and scaling, if required.

How to Autotune a Loop

1. Enter the desired set point or one that is in the middle of the expected range of set points that you want to tune for.
2. Initiate an autotune. (See Autotuning in this chapter.)

Note:

Enable TRU-TUNE+ only after autotune is complete. It should be disabled before autotune is initiated.

When autotuning is complete, the PID parameters should provide good control. As long as the loop is in the adaptive control mode, TRU-TUNE+ continuously tunes to provide the best possible PID control for the process.

WARNING! 

During autotuning, the controller sets the output to 100 percent and attempts to drive the Process Value toward the set point. Enter a set point and heat and cool power limits that are within the safe operating limits of your system.

Inputs

Calibration Offset

Calibration offset allows a device to compensate for an inaccurate sensor, lead resistance or other factors that affect the input value. A positive offset increases the input value, and a negative offset decreases the input value. The input offset value can be viewed or changed with Calibration Offset `.CR` (Operations Page, Analog Input Menu).

Calibration

Before performing any calibration procedure, verify that the displayed readings are not within published specifications by inputting a known value from a precision source to the analog input. Next, subtract the displayed value with the known value and compare this difference to the published accuracy range specification for that type of input.

Use of the Calibration Offset `.CR` parameter found in the Operations Page `OPER`, Analog Input Menu `AI`, shifts the readings across the entire displayed range by the offset value. Use this parameter to compensate for sensor error or sensor placement error. Typically this value is set to zero.

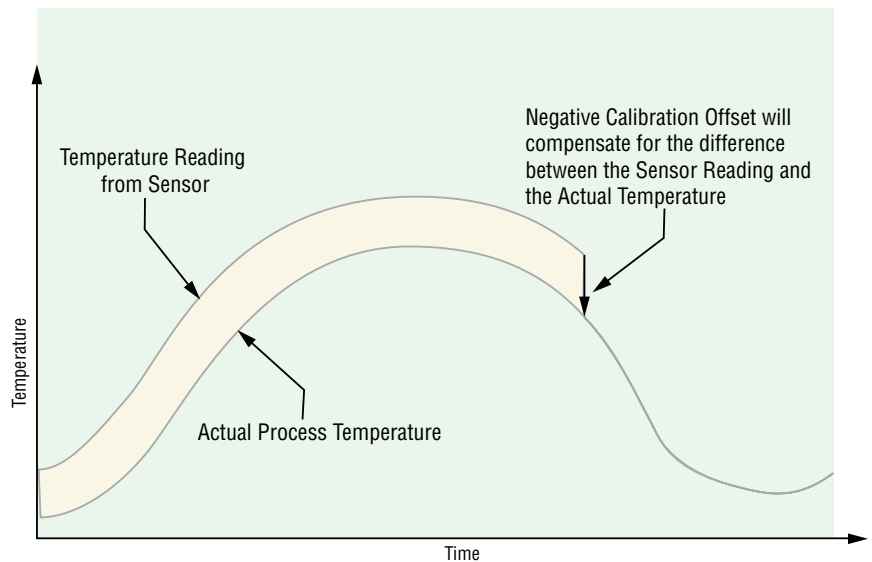

Equipment required while performing calibration:

Obtain a precision source for millivolts, volts, milliamperes or resistance depending on the sensor type to be calibrated. Use copper wire only to connect the precision source to the controller's input. Keep leads between the precision source and controller as short as possible to minimize error. In addition, a precision volt/ohm meter capable of reading values to 4 decimal places or better is recommended. Prior to calibration, connect this volt/ohm meter to the precision source to verify accuracy. Actual input values do NOT have to be exactly the recommended values, but it IS critical that the actual value of the signal connected to the controller be accurately known to at least four digits.

Calibration of Analog Inputs:

To calibrate an analog input, you will need to provide a source of two electrical signals or resistance values near the extremes of the range that the application is likely to utilize. See recommended values below:

Sensor Type	Precision Source Low	Precision Source High
thermocouple	0.000 mV	50.000 mV
millivolts	0.000 mV	50.000 mV
volts	0.000V	10.000V
milliamps	0.000 mA	20.000 mA
100 Ω RTD	50.00 Ω	350.0 Ω
1,000 Ω RTD	500.0 Ω	3,500 Ω
thermistor 5 kΩ	50.00	5,000
thermistor 10 kΩ	150.0	10,000
thermistor 20 kΩ	1,800	20,000
thermistor 40 kΩ	1,700	40,000
potentiometer	0.000	1,200

Note:

The user may only calibrate one sensor type. If the calibrator interferes with open thermocouple detection, set Sensor Type `SEn` in Setup Page `SEt`, Analog Input Menu `Ai` to millivolt `P7u` instead of Thermocouple `EE` to avoid interference between the calibrator and open thermocouple detect circuit for the duration of the calibration process. Be sure to set sensor type back to the thermocouple type utilized.

Note:

The Electrical Measurement value, will be in the units that are selected. I.E. Millivolts, volts, milliamps, or ohms.

1. Disconnect the sensor from the controller.
2. Record the Calibration Offset `.Ea` parameter value in the Operations Page `oPEr`, Analog Input Menu `Ai`, then set value to zero.
3. Wire the precision source to the appropriate controller input terminals to be calibrated. Do not have any other wires connected to the input terminals. Please refer to the Install and Wiring section of this manual for the appropriate connections.
4. Ensure the controller sensor type is programmed to the appropriate Sensor Type `SEn` to be utilized in the Setup Page `SEt`, Analog Input Menu `Ai`.
5. Enter Factory Page `FEtY`, Calibration Menu `CaL` via front panel or Configurator Software.
6. Select the Calibration `CaL` input instance to be calibrated. This corresponds to the analog input to be calibrated.
7. Set Electrical Input Slope `EL .5` to 1.000 and Electrical Input Offset `EL .o` to 0.000 (this will cancel any prior user calibration values)
8. Input a Precision Source Low value. Read Electrical Measurement value `P7u` of controller via PM3 LEGACY™ PID Configurator or RUI. This will be referred to as Electrical Measured Low. Record low value _____
9. Input a Precision Source High value.

10. Read Electrical Measurement value $P7_{\square}$ of controller via PM3 LEGACY™ PID Configurator or RUI. This will be referred to as Electrical Measured High. Record high value _____

11. Calculated Electrical Input Slope = (Precision High – Precision Low) / (Electrical Measured High - Electrical Measured Low) Calculated Slope value _____

12. Calculated Electrical Input Offset = Precision Low - (Electrical Input Slope * Measured Low) Calculated Offset value _____

13. Enter the calculated Electrical Input Slope $EL_{.5}$ and Electrical Input Offset $ELI_{.0}$ into the controller.

14. Exit calibration menu.

15. Validate calibration process by utilizing a calibrator to the analog input.

16. Enter calibration offset as recorded in step 2 if required to compensate for sensor error.

Setting Electrical Input Slope $EL_{.5}$ to 1.000 and Electrical Input Offset $ELI_{.0}$ to 0.000, restores factory calibration as shipped from factory.

Filter Time Constant

Filtering smooths an input signal by applying a first-order filter time constant to the signal. Filtering the displayed value makes it easier to monitor. Filtering the signal may improve the performance of PID control in a noisy or very dynamic system.

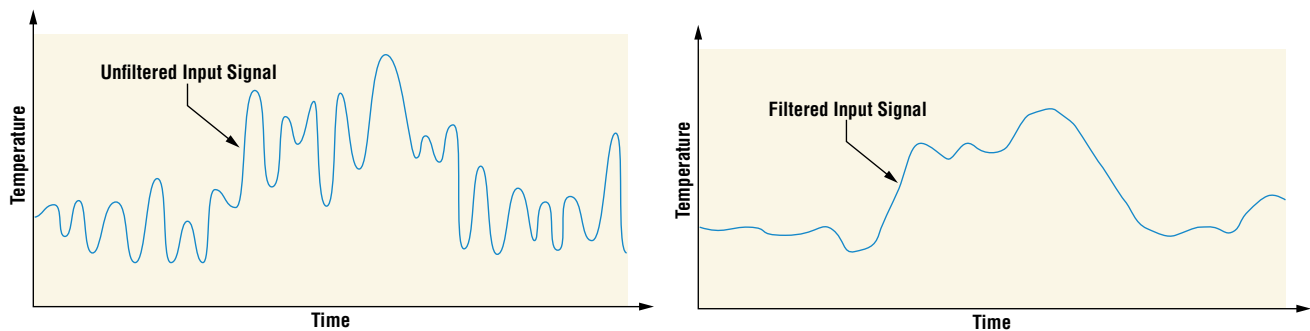

Adjust the filter time interval with Filter Time $F_{.L}$ (Setup Page, Analog Input Menu). Example: With a filter value of 0.5 seconds, if the process input value instantly changes from 0 to 100 and remained at 100, the display will indicate 100 after five time constants of the filter value or 2.5 seconds.

Sensor Selection

You need to configure the controller to match the input device, which is normally a thermocouple, RTD or process transmitter.

Select the sensor type with Sensor Type SE_n (Setup Page, Analog Input Menu).

Set Point Minimum and Maximum

The controller has the ability to restrict the Set Points for the following modes of operation:

- For closed loop control use Minimum Set Point and Maximum Set Point found in the Setup Page, Loop Menu.
- For Manual Power (open loop control) use Minimum Power and Maximum Power found in the Setup Page, Loop Menu.

Scale High and Scale Low

When an analog input is selected as process voltage or process current input, you must choose the value of voltage or current to be the low and high ends. For example, when using a 4 to 20 mA input, the scale low value would be 4.00 mA and the scale high value would be 20.00 mA. Commonly used scale ranges are: 0 to 20 mA, 4 to 20 mA, 0 to 5V, 1 to 5V and 0 to 10V.

You can create a scale range representing other units for special applications. You can reverse scales from high values to low values for analog input signals that have a reversed action. For example, if 50 psi causes a 4 mA signal and 10 psi causes a 20 mA signal.

Scale low and high low values do not have to match the bounds of the measurement range. These along with range low and high provide for process scaling and can include values not measurable by the controller. Regardless of scaling values, the measured value will be constrained by the electrical measurements of the hardware. Select the low and high values with Scale Low *SLo* and Scale High *Shi*. Select the displayed range with Range Low *rLo* and Range High *rhi* (Setup Page, Analog Input Menu).

Range High and Range Low

With a process input, you must choose a value to represent the low and high ends of the current or voltage range. Choosing these values allows the controller's display to be scaled into the actual working units of measurement. For example, the analog input from a humidity transmitter could represent 0 to 100 percent relative humidity as a process signal of 4 to 20 mA. Low scale would be set to 0 to represent 4 mA and high scale set to 100 to represent 20 mA. The indication on the display would then represent percent humidity and range from 0 to 100 percent with an input of 4 to 20 mA. Select the low and high values with Range Low *rLo* and Range High *rhi* (Setup Page, Analog Input Menu).

Ten Point Linearization

The linearization function allows a user to re-linearize a value read from an analog input. There are 10 data points used to compensate for differences between the sensor value read (input point) and the desired value (output point). Multiple data points enable compensation for non-linear differences between the sensor readings and target process values over the thermal or process system operating range. Sensor reading differences can be caused by sensor placement, tolerances, an inaccurate sensor or lead resistance.

The user specifies the unit of measurement and then each data point by entering an input point value and a corresponding output point value. Each data point must be incrementally higher than the previous point. The linearization function will interpolate data points linearly in between specified data points.

Note:

Output Point 1 will be the minimum value that can be displayed, and Output Point 10 will be the maximum value that can be displayed. Consider setting Output Point 1 to the minimum operating range, and Output Point 10 to the maximum operating range; for that sensor type.

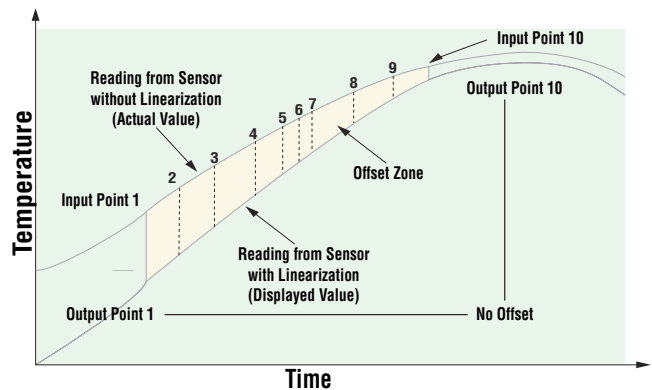

Outputs

Duplex

Certain systems require that a single process output, control both heating and cooling outputs. An PM3 LEGACY™ PID controller with a process output can function as two separate outputs. With a 4 to 20mA output the heating output will operate from 12 to 20mA (0 to +100 percent) and the cooling output will operate from 12 to 4mA (0 to -100 percent).

In some cases this type of output is required by the device that the PM3 LEGACY™ PID controls, such as a three-way valve that opens one way with a 12 to 20mA signal and opens the other way with a 4 to 12mA signal. This feature reduces the overall system cost by using a single output to act as two outputs.

Output 1 can be ordered as process output. Select duplex *DUPL* as the Output Function *F_n* (Setup Page, Output Menu). Set the output to volts *VOLT* or milliamps *MA* with Type *OUTY*. Set the range of the process output with Scale Low *SL0* and Scale High *SH1*.

Retransmitting a Process Value or Set Point

The retransmit feature allows a process output to provide an analog signal that represents the set point or process value. The signal may serve as a remote set point for another controller or as an input for a chart recorder documenting system performance over time.

In choosing the type of retransmit signal the operator must take into account the input impedance of the device to be retransmitted to and the required signal type, either voltage or milliamps. Typically applications might use the retransmit option to record one of the variables with a chart recorder or to generate a set point for other controls in a multi-zone application.

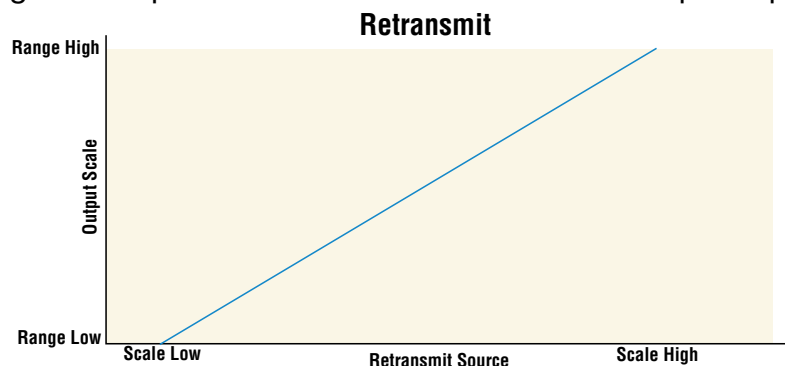

Output 1 can be ordered as process output. Select retransmit *RTN* as the Function *F_n* (Setup Page, Output Menu). Set the output to volts *VOLT* or milliamps *MA* with Type *OUTY*. Select the signal to retransmit with Retransmit Source *RSR*. Set the range of the process output with Scale Low *SL0* and Scale High *SH1*. Scale the retransmit source to the process output with Range Low *RL0* and Range High *RH1*.

When the retransmit source is at the Range Low value, the retransmit output will be at its Scale Low value. When the retransmit source is at the Range High value, the retransmit output will be at its Scale High value.

Cool Output Curve

A nonlinear output curve may improve performance when the response of the output device is nonlinear. If a cool output uses one of the nonlinear curves a PID calculation yields a lower actual output level than a linear output would provide.

These output curves are used in plastics extruder applications: curve A for oil-cooled extruders and curve B for water-cooled extruders. Select a nonlinear cool output curve with Cool Output Curve `[[[` (Setup Menu, Loop Menu).

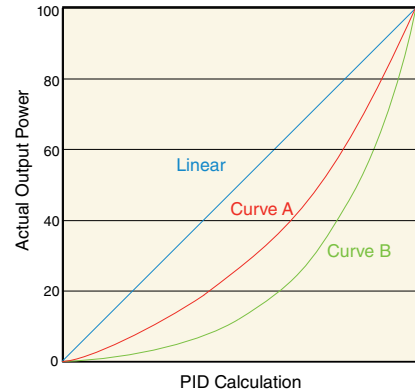

Control Methods

Output Configuration

Each controller output can be configured as a heat output, a cool output, an alarm output or deactivated. No dependency limitations have been placed on the available combinations. The outputs can be configured in any combination. For instance, all three could be set to cool.

Heat and cool outputs use the set point and Operations parameters to determine the output value. All heat and cool outputs use the same set point value. Heat and cool each have their own set of control parameters. All heat outputs use the same set of heat control parameters and all cool outputs use the same set of cool output parameters.

Each alarm output has its own set of configuration parameters and set points, allowing independent operation.

Auto (closed loop) and Manual (open loop) Control

The controller has two basic modes of operation, auto mode and manual mode. Auto mode allows the controller to decide whether to perform closed-loop control or to follow the settings of Input Error Failure `FRIL` (Setup Page, Loop Menu). The manual mode only allows open-loop control. The PM3 LEGACY™ PID controller is normally used in the auto mode. The manual mode is usually only used for specialty applications or for troubleshooting.

Manual mode is open-loop control that allows the user to directly set the power level to the controller's output load. No adjustments of the output power level occur based on temperature or set point in this mode.

In auto mode, the controller monitors the input to determine if closed-loop control is possible. The controller checks to make certain a functioning sensor is providing a valid input signal. If a valid input signal is present, the controller will perform closed-loop control. Closed-loop control uses a process sensor to determine the difference between the process value and the set point. Then the controller applies power to a control

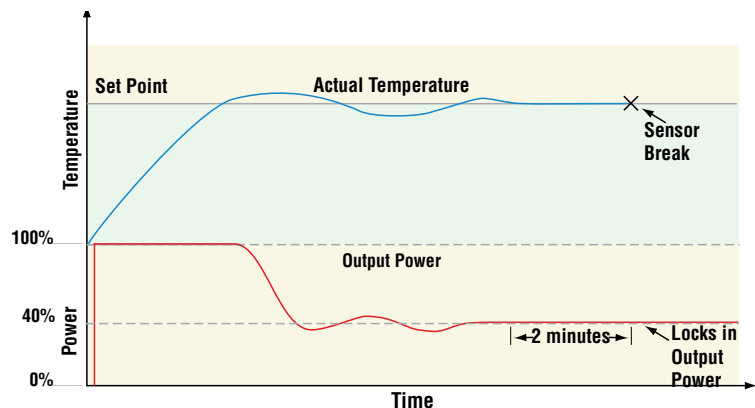



output load to reduce that difference. If a valid input signal is not present, the controller will indicate an input error message in the upper display and *ALt n* in the lower display and respond to the failure according to the setting of Input Error Failure *FR ,L*. You can configure the controller to perform a bumpless transfer *bPLS*, switch power to output a preset fixed level *PRAn*, or turn the output power off.

Bumpless transfer will allow the controller to transfer to the manual mode using the last power value calculated in the auto mode if the process had stabilized at a ± 5 percent output power level for the time interval or 10 seconds, (whichever is longer) prior to sensor failure, and that power level is less than 75 percent. Reverse Bumpless functionality will take effect when the control is changed from Manual to Auto mode. The control will preload the Manual Power value into the Integral and Proportional Terms, which will allow for a bumpless transition. The normal PID action will then take over to control the output to the Set Point value.



Note:

Reverse bumpless ignores the transition from Off to Auto.



Input Error Latching *,Er* (Setup Page, Analog Input Menu) determines the controller's response once a valid input signal returns to the controller. If latching is on, then the controller will continue to indicate an input error until the error is cleared. To clear a latched alarm, press the Advance Key  then the Up Key . If latching is off, the controller will automatically clear the input error and return to reading the temperature. If the controller was in the auto mode when the input error occurred, it will resume closed-loop control. If the controller was in manual mode when the error occurred, the controller will remain in open-loop control. The Manual Control Indicator Light % is on when the controller is operating in manual mode.



You can easily switch between modes if the Control Mode *CP7* parameter is selected to appear in the Home Page.

To transfer to manual mode from auto mode:

1. Press the Advance Key  until *CP7* appears in the green display. The red display will display *Auto* for auto mode.
2. Use the Up  or Down  keys to select *PRAn*. The manual set point value will be recalled from the last manual operation.

To transfer to auto mode from manual mode:

1. Press the Advance Key  until *CP7* appears in the green display. The red display will display *PRAn* for manual mode.
2. Use the Up  or Down  keys to select *Auto*. The automatic set point value will be recalled from the last automatic operation.

Changes take effect after three seconds or immediately upon pressing either the Advance Key  or the Infinity Key .

On-Off Control

On-off control switches the output either full on or full off, depending on the input, set point and hysteresis values. The hysteresis value indicates the amount the process value must deviate from the set point to turn on the output. Increasing the value decreases the number of times the output will cycle. Decreasing hysteresis improves controllability. With hysteresis set to 0, the process value would stay closer to the set point, but the output would switch on and off more frequently, and may result in the output "chattering." On-off control can be selected with Heat Algorithm *hAg* or Cool Algorithm *CAg* (Setup Page, Loop Menu). On-off hysteresis can be set with On/Off Heat Hysteresis *hhY* or On/Off Cool Hysteresis *ChY* (Operations Page, Loop Menu).

Note:

Input Error Failure Mode **FRIL** does not function in on-off control mode. The output goes off.

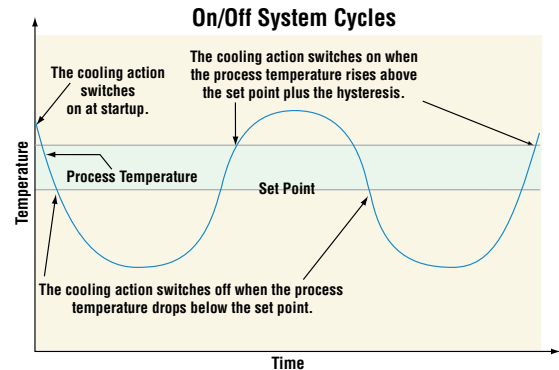
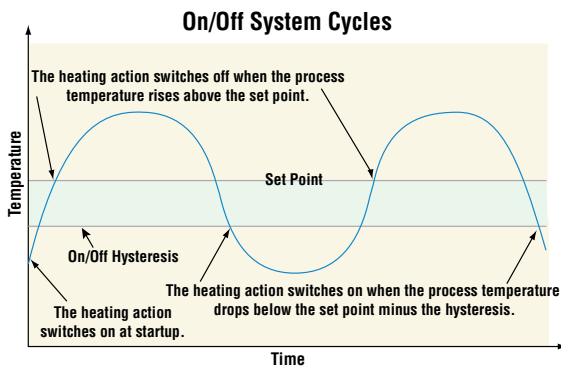

Proportional and (P) Control

Some processes need to maintain a temperature or process value closer to the set point than on-off control can provide. Proportional control provides closer control by adjusting the output when the temperature or process value is within a proportional band. When the value is in the band, the controller adjusts the output based on how close the process value is to the set point. The closer the process value is to the set point, the lower the output power. This is similar to backing off on the gas pedal of a car as you approach a stop sign. It keeps the temperature or process value from swinging as widely as it would with simple on-off control. However, when the system settles down, the temperature or process value tends to “droop” short of the set point.

With proportional control, the output power level equals the set point minus the process value divided by proportional band times 100. In an application with one output assigned to heating and another assigned to cooling, each will have a separate proportional parameter. The heating parameter takes effect when the process temperature is lower than the set point, and the cooling parameter takes effect when the process temperature is higher than the set point.

Adjust the proportional band with Heat Proportional Band **hPB** or Cool Proportional Band **cPB** (Operations Page, Loop Menu).

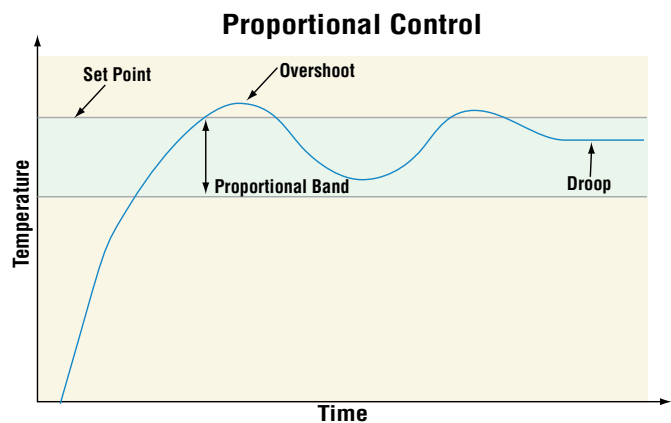

Proportional and Integral (PI) Control

The droop caused by proportional control can be corrected by adding integral (reset) control. When the system settles down, the integral value is tuned to bring the temperature or process value closer to the set point. Integral determines the speed of the correction, but this may increase the overshoot at startup or when the set point is changed. Too much integral action will make the system unstable. Adjust the integral with Time Integral **tI** (Operations Page, Loop Menu).

Proportional, Integral and Derivative (PID) Control

Use derivative (rate) control to minimize the overshoot in a PI-controlled system. Derivative (rate) adjusts the output power immediately based on the rate of change in the temperature or process value. Too much derivative (rate) will make the system sluggish. Adjust the derivative with Time Derivative t_d (Operations Page, Loop Menu).

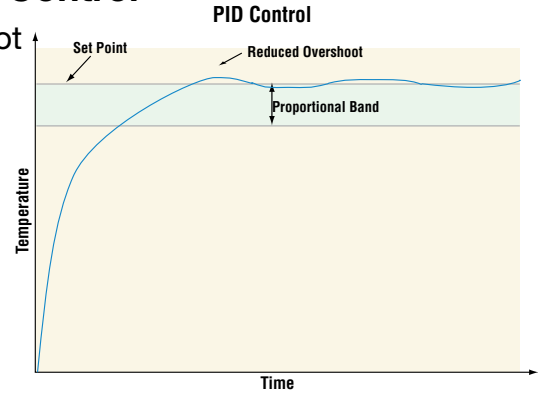

Dead Band

In a PID application the dead bands above and below the set point can save an application's energy and wear by maintaining process temperature within acceptable ranges. Proportional action ceases when the process value is within the dead band. Integral action continues to bring the process temperature to the set point. Using a positive dead band value keeps the two systems from fighting each other.

When the dead band value is zero, the heating output activates when the temperature drops below the set point, and the cooling output switches on when the temperature exceeds the set point.

When the dead band value is a negative value, both heating and cooling outputs are active when the temperature is near the set point. Adjust the dead band with Dead Band db (Operations Page, Loop Menu).

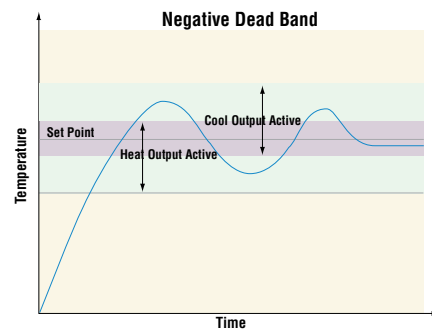
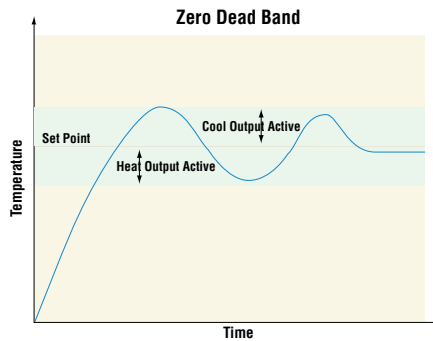
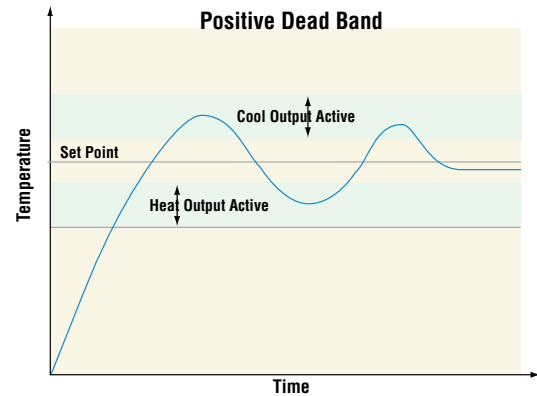

Variable Time Base

Variable time base is the preferred method for controlling a resistive load, providing a very short time base for longer heater life. Unlike phase-angle firing, variable-time-base switching does not limit the current and voltage applied to the heater. With variable time base outputs, the PID algorithm calculates an output between 0 and 100%, but the output is distributed in groupings of three ac line cycles. For each group of three ac line cycles, the controller decides whether the power should be on or off. There is no fixed cycle time since the decision is made

for each group of cycles. When used in conjunction with a zero cross (burst fire) device, such as a solid-state power controller, switching is done only at the zero cross of the ac line, which helps reduce electrical noise (RFI). Variable time base should be used with solid-state power controllers, such as a solid-state relay (SSR) or silicon controlled rectifier (SCR) power controller. Do not use a variable time base output for controlling electromechanical relays, mercury displacement relays, inductive loads or heaters with unusual resistance characteristics.

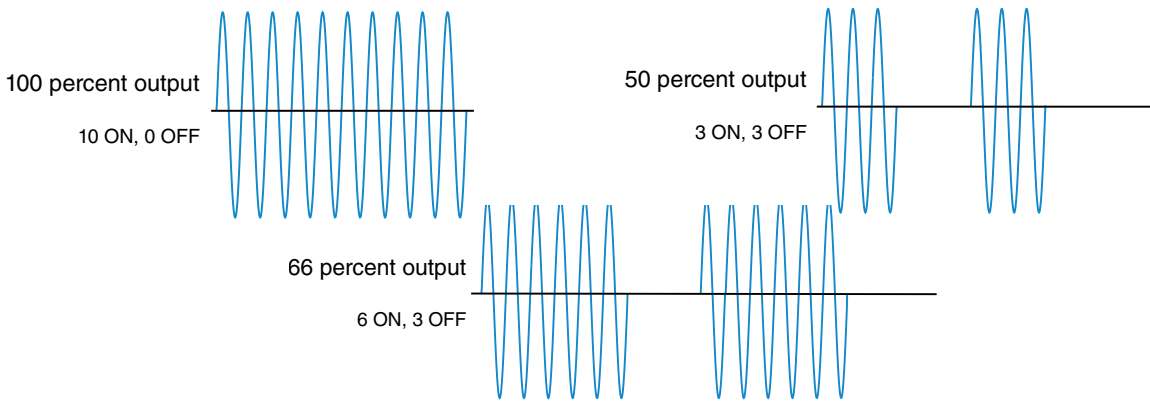

The combination of variable time base output and a solid-state relay can inexpensively approach the effect of analog, phase-angle fired control. Select the AC Line Frequency **A.C.L.F** (Setup Page, Global Menu), 50 or 60 Hz.

Single Set Point Ramping

Ramping protects materials and systems that cannot tolerate rapid temperature changes. The value of the ramp rate is the maximum degrees per minute or hour that the system temperature can change.

Select Ramp Action **r.P** (Setup Page, Loop Menu):

- oFF** ramping not active.
- St r** ramp at startup.
- St Pt** ramp at a set point change.
- both** ramp at startup or when the set point changes.

Select whether the rate is in degrees per minute or degrees per hour with Ramp Scale **r.S.C**. Set the ramping rate with Ramp Rate **r.r.t** (Setup Page, Loop Menu).

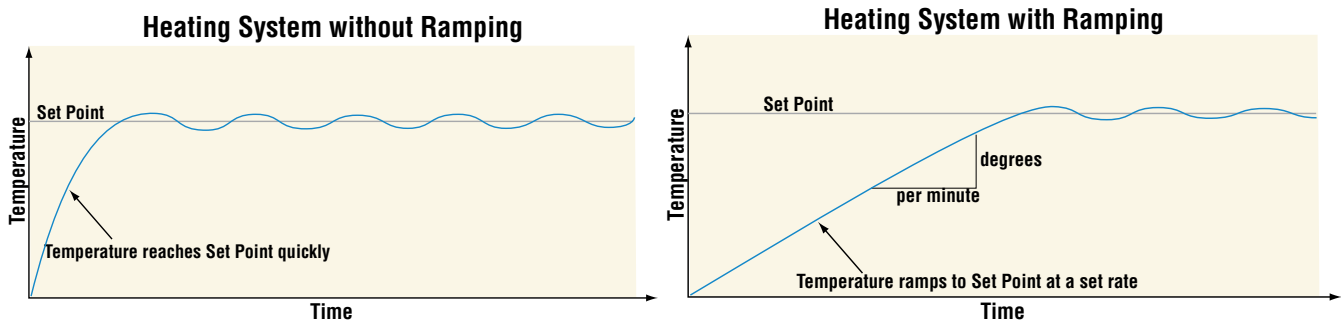





















Timer Function

























1. When Timer Enable t_{EN} is set to yes YES and the timer is started (you define which key combination this is), the controller will switch from Set Point $CLSP1$ to Closed Loop Timer Set Point $CLT51$. If the timer is interrupted, the timer is terminated and the time remaining is reset to its initial value.
2. When Timer Start Method t_{SM} is set to:
 - a. **Immediate** IMM , the timer starts as soon as the counter is initiated. When Time Remaining t_r1 equals zero, the set point changes from Closed Loop Timer Set Point $CLT51$ back to Set Point $CLSP1$. A flashing colon $00:00$ indicates that a countdown is in progress.
 - b. **Ready Band** RDY , the set point changes and when the temperature is within ready band, the ready band indicator  lights up and the countdown timer starts and continues as long as the temperature is within the ready band. When Time Remaining t_r1 equals zero, the set point changes from Closed Loop Timer Set Point $CLT51$ back to Set Point $CLSP1$. A flashing colon $00:00$ indicates that a countdown is in progress.
 - c. **Ready Acknowledge** $RDYA$, the set point changes, and when the temperature is within the ready band, the ready band indicator  lights up. The user must then acknowledge (you define which key combination for this) that the countdown timer should start and continue as long as the temperature is within the ready band. When Time Remaining t_r1 equals zero, the set point changes from Closed Loop Timer Set Point $CLT51$ back to Set Point $CLSP1$. A flashing colon $00:00$ indicates that a countdown is in progress.
 - d. **Power** $PLUR$, the timer starts when the controller is turned on. When Time Remaining t_r1 equals zero, the set point changes from Closed Loop Timer Set Point $CLT51$ back to Set Point $CLSP1$. A flashing colon $00:00$ indicates that a countdown is in progress.
3. In Setup Page, Output Menu, Output Function fn can be assigned as Timer Event Output 1 $TEO1$, Timer Event Output 2 $TEO2$ or Timer Event Output 3 $TEO3$. Timer Event Output 1 is active during timing, Timer Event Output 2 is deactivated during timing and Timer Event Output 3 produces a pulse at the end of the timing sequence. These signals may be used to monitor timer activity. Process outputs may not be assigned to Timer Event Outputs.
4. The home display is customized in the Factory Page, Custom Menu. You may program the display to alternate between display pairs. See display pairs in the Setup Page, Global Menu. As an example, we could show the process temperature in the upper display and have the lower display alternate between the countdown time remaining and the active set point.

Note:

The timer feature is only available for control loop 1 of two-loop controllers. Time is entered in hours, minutes and seconds. Countdown time will use the entered time but display the time remaining in either hh:mm or mm:ss format, based on your settings. The colon pulses in one-second intervals during a countdown, to indicate that timing is underway. Parameters that appear in the Home page have the number 1 at the end of the displayed parameter. As an example, $hOUR$ in the Setup Page, Timer Menu will be displayed as $hOU1$ in the Home Page.

Setting Up the Timer Function

1. Press and hold up  and down  arrow keys for 6 seconds to enter into the Setup Page *SEt*.
2. Up arrow  to Timer Menu *tPPr*.
3. Advance  to Timer Enable *t .En* to make selection using the up  and down  arrow keys to select from the options below:
YES Yes
no No
4. Advance  to Timer Start Method *t .St* to select the method that will start the timer.
5. Use the up arrow  to select from the options below:
Imm Immediate
rdy Ready Band
rdyA Ready Ack
Pwr Power
6. Advance  to Source Function A *SFnA* to select which input will start/terminate the timer. Use the up arrow  to select from the options below:
none None
dio Digital I/O
Fun Function Key
7. Advance  to Source Instance A and use the up arrow  to make a selection below:
If Source Function A of previous step is set to None *none*:
1 Does not matter which number is here
5 .A Source Instance A
If Source Function A of previous step is set to Digital I/O *dio*:
5 Select 5 to 6
5 .A Source Instance A
If Source Function A of previous step is set to Function Key *Fun*:
1 Infinity Key
2 Infinity Key
6 Hold infinity key for 2 seconds
7 Infinity  and Down arrow 
8 Infinity  and Up arrow 
5 .A Source Instance A
8. Advance  to Source Function C *SFnC* to select the analog source for the ready band. Use the up arrow  to select from the options below:
Pu Process Value
none None
Ai Analog Input
Lnr Linearization
9. Advance  and use the up arrow  to make a selection below:
1 1 or (2, if second instance of Source Function C)

10. Advance  to Source Function D *SFnD* to select which input will acknowledge the ready band. Use the up arrow  to select from the options below:
- nOnE* None
 - dIo* Digital I/O
 - FUn* Function Key
11. Advance  to Source Instance D and use the up arrow  to make a selection below:
- If Source Function A of previous step is set to None *nOnE*:
- 1* Does not matter which number is here
 - 5Id* Source Instance D
- If Source Function A of previous step is set to Digital I/O *dIo*:
- 5* Select 5 to 6
 - 5Id* Source Instance D
- If Source Function A of previous step is set to Function Key *FUn*:
- 1* Infinity Key
 - 2* Infinity Key
 - 6* Hold infinity key for 2 seconds
 - 7* Infinity  and Down arrow 
 - 8* Infinity  and Up arrow 
 - 5Id* Source Instance D
12. Advance  to Time Remaining *tR*, read only, display in hh:mm or mm:ss.
13. Advance  to Ready Band State *r.bS*, read only, displayed as yes *YEs* or no *nO*.
14. Advance  to Ready Band *rDY* to enter the value for Ready Band using Up  or Down arrow .
15. Advance  to Time Format *t.FoR* to select the time format. Use the up arrow  to make selection below:
- tHrM* Time Hours:Minutes
 - tPnS* Time Minutes:Seconds
16. Advance  to Countdown Time to enter hours, minutes and seconds using the Up  or Down arrow .
- hOr* Hours, then Advance 
 - Pn* Minutes, then Advance 
 - SEc* Seconds
17. Advance  to Closed Loop Timer Set Point *CLSP* to enter the temperature during counting using the Up  or Down arrow .
18. Advance  to Signal Time *St* to enter time in seconds for Timer Event Output 3 *tEo3* to be active at end of countdown time.
19. Press and hold the Infinity  or Reset key for more than 2 seconds to go to Home Page.
20. See programming custom home page in factory page, custom menu to change the display parameters such as active process value, closed loop set point time, closed loop timer set point and time remaining as appropriate for the application.

Alarms

Alarms are activated when the output level, process value or temperature leaves a defined range. A user can configure how and when an alarm is triggered, what action it takes and whether it turns off automatically when the alarm condition is over. Configure alarm outputs in the Setup Page before setting alarm set points. Alarms do not have to be assigned to an output. Alarms can be monitored and controlled through the front panel or by using software.

Process and Deviation Alarms

A process alarm uses one or two absolute set points to define an alarm condition. A deviation alarm uses one or two set points that are defined relative to the set point used by the control loop. High and low alarm set points are calculated by adding or subtracting offset values from the set point used by the control loop. If the set point changes, the window defined by the alarm set points automatically moves with it. Select the type with Type **RLY** (Setup Page, Alarm Menu).

Set Points

The high set point defines the process value or temperature that will trigger a high side alarm. The set point defines the temperature that will trigger a low side alarm. For deviation alarms, a negative set point represents a value below set point used by the control loop. A positive set point represents a value above the set point used by the control loop. View or change alarm set points with Low Set Point **RLo** and High Set Point **Rhi** (Operations Page, Alarm Menu).

Hysteresis

An alarm state is triggered when the process value reaches the high or low set point. Hysteresis defines how far the process must return into the normal operating range before the alarm can be cleared. Hysteresis is a zone inside each alarm set point.

This zone is defined by adding the hysteresis value to the low set point or subtracting the hysteresis value from the high set point. View or change hysteresis with Hysteresis **RHY** (Setup Page, Alarm Menu).

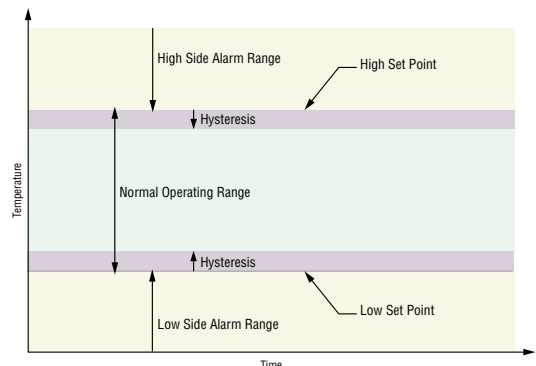

Alarm Set Points and Hysteresis

Latching

A latched alarm will remain active after the alarm condition has passed. It can only be deactivated by the user. An active message, such as an alarm message, will cause the display to toggle between the normal settings and the active message in the red display and **ALLEN** in the green display. Push the Advance Key **⏏** to display **ALARM** in the red display and the message source in the green display. Use the Up **▲** or Down **▼** keys to scroll through possible responses, such as Clear **CLR** or Silence **SIL**. Then push the Advance **⏏** or Infinity **∞** key to execute the action.

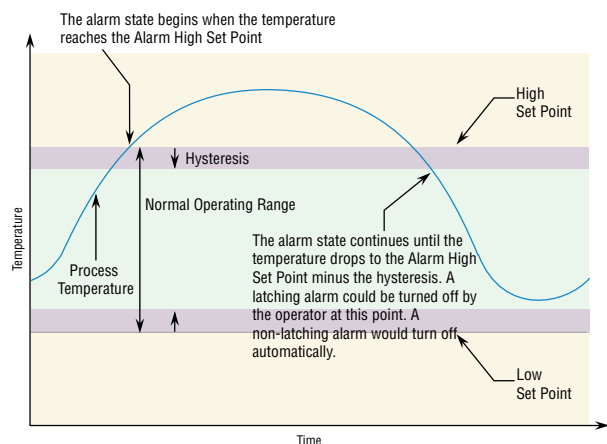





Alarm Response with Hysteresis

See the Keys and Displays chapter and the Home Page chapter for more details. An alarm that is not latched (self-clearing) will deactivate automatically when the alarm condition has passed. Turn latching on or off with Latching *RLA* (Setup Page, Alarm Menu).

Silencing

If silencing is on the operator can disable the alarm output while the controller is in an alarm state. The process value or temperature has to enter the normal operating range beyond the hysteresis zone to activate the alarm output function again. An active message, such as an alarm message, will cause the display to toggle between the normal settings and the active message in the upper display and *ALERT* in the lower display.

1. Push the Advance Key  to display *ALRT* in the red display and the message source in the green display.
2. Use the Up  and Down  keys to scroll through possible responses, such as Clear *CLR* or Silence *SIL*. Then push the Advance  or Infinity  key to execute the action.

See the Keys and Displays chapter and the Home Page chapter for more details. Turn silencing on or off with Silencing *RSI* (Setup Page, Alarm Menu).

Blocking

Blocking allows a system to warm up after it has been started up. With blocking on, an alarm is not triggered when the process temperature is initially lower than the low set point or higher than the high set point. The process temperature has to enter the normal operating range beyond the hysteresis zone to activate the alarm function. If the PM3 LEGACY™ PID has an output that is functioning as a deviation alarm, the alarm is blocked when the set point is changed, until the process value re-enters the normal operating range. Turn blocking on or off with Blocking *ABL* (Setup Page, Alarm Menu).

Open Loop Detection

When Open Loop Detection is enabled *LDE*, the controller will look for the power output to be at 100%. Once there, the control will then begin to monitor the Open Loop Detect Deviation *LDD* as it relates to the value entered for the Open Loop Detect Time *LDT*. If the specified time period expires and the deviation does not occur, an Open Loop Error will be triggered. Once the Open Loop Error condition exists the control mode will go off and an Open Loop message will be display. If the process value goes in the opposite direction, a Reversed Loop message is display. The sensor is likely wired in reverse polarity.

Note:

All prompts identified in this section can be found in the Loop Menu of the Setup Page.

Using Lockout and Password Security

If unintentional changes to parameter settings might raise safety concerns or lead to downtime, you can use the lockout feature to make them more secure. There are two methods of lockout that can be deployed, both of which are accessible from the Factory Page.

Method 1- Change the value of the Read Lock *RLC* (1 to 5) and Set Lock *SLC* (0 to 5) prompts where the higher the value or setting for each translates to a higher security clearance (greater access).

Method 2- Enable Password Security *PASE* and then modify the Lock Level *LCL* value which ranges from 1 to 5. See the section entitled *Using Lockout Method 2* for more detail.

Using Lockout Method 1 (Read and Set Lock)

All Pages have security levels assigned where two of those cannot be changed (Home and Setup). Defaults (factory settings) for each are shown below:

- Home Page = 1
- Operations Page = 2 (changeable to 1, 2 or 3)
- Setup Page = 4
- Profiling Page = 3 (changeable to 1, 2 or 3)
- Factory Page = 5*











* The Factory Page is always visible where all menus within it may or may not be visible/writable. For further detail see table "*Factory Page Menus*".

The table below represents the various levels of lockout for the Set Lockout Security prompt *SLoC* and the Read Lockout Security prompt *rLoC*. Looking at the table, "Y" equates to yes (can write/read) where "N" equates to no (cannot write/read). The colored cells simply differentiate one level from the next while also showing the level where read/write is enabled. As stated previously, the Set Lockout has 6 levels (0 to 5) of security where the Read Lockout has 5 (1 to 5). Therefore, level "0" applies to Set Lockout only.

Lockout Security <i>SLoC</i> and <i>rLoC</i>						
Pages	Security Level					
	0	1	2	3	4	5
Home Page (cannot be changed)	N	Y	Y	Y	Y	Y
Operations Page	N	N	Y	Y	Y	Y
Setup Page (cannot be changed)	N	N	N	N	Y	Y
Profile Page	N	N	N	Y	Y	Y
Factory Page	Y	Y	Y	Y	Y	Y





Being able to change the page security level for the Operations and Profile pages allows a user to give access to the Profile Page while locking out the Operations Page. The following example shows how the Lockout feature may be used to accomplish this:

Changing Security Levels:

1. From the Home Page, press and hold the Infinity Key  and the Advance Key  for approximately six seconds. *CUSt* will appear in the red display and *FCEY* will appear in the green display.
2. Press the Up Key  until *LoC* appears in the red display and *FCEY* will appear in the green display.
3. Press the Advance Key  until Lock Operations prompt *LoC.o* appears in the bottom display.
4. Press the Up Key  to change the default value from *2* to *3*.
5. Press the Advance Key  again and change the Lock Profiling prompt *LoC.P* appears in the bottom display.
6. Press the Down Key  to change the default value from *3* to *2*.
7. Press the Advance Key  until Read Lock *rLoC* appears in the bottom display.
8. Press the Down Key  to change the default value from *5* to *2*.
9. Press the Advance Key  until Set Lock *SLoC* appears in the bottom display.
10. Press the Down Key  to change the default value from *5* to *4*.

With the above settings, the Home Page and the Profiling Page can be accessed, and all writable parameters can be written to. Due to the Read lock setting of 2, all pages with security levels greater than 2 will be locked out (inaccessible).

Another example of Method 1 lockout usage could be that an operator wants read access to all pages while allowing read/write access to the Home Page and the Lockout Menu only. To setup this scenario follow the steps below:

1. From the Home Page, press and hold the Infinity Key  and the Advance Key  for approximately six seconds. *CUSE* will appear in the red display and *FLEY* will appear in the green display.
2. Press the Up Key  until *LoE* appears in the red display and *FLEY* will appear in the green display.
3. Press the Advance Key  until Read Lock *rLoE* appears in the bottom display and change it to *5*.
4. Press the Advance Key  until Set Lock *SLoE* appears in the bottom display and change it to *1*.

Although the Factory Page is always visible, some menus within it can be restricted.

Lockout Security <i>SLoE</i> and <i>rLoE</i>						
Factory Page Menus						
Menus	Security Level					
	0	1	2	3	4	5
Custom Menu	N	N	N	N	N	Y
Lockout Menu*	Y	Y	Y	Y	Y	Y
Diagnostic Menu**	N	Y	Y	Y	Y	Y
Calibration Menu	N	N	N	N	N	Y

* Using lockout Method 1 with *SLoE* set to 0, all writable parameters within the control will be inhibited (not writable) with two exceptions, *SLoE* and *rLoE*. As shown below, both of these parameters can always be seen and modified.

** Diagnostic Menu and all associated prompts are always visible and never writable

Lockout Security <i>SLoE</i> and <i>rLoE</i>						
Factory Page Menu Parameters						
Parameters	Security Level					
	0	1	2	3	4	5
<i>LoEo</i>	N	Y	Y	Y	Y	Y
<i>LoEP</i>	N	Y	Y	Y	Y	Y
<i>PA5E</i>	N	Y	Y	Y	Y	Y
<i>rLoE</i>	Y	Y	Y	Y	Y	Y
<i>SLoE</i>	Y	Y	Y	Y	Y	Y

Note:





Using Method 1 Lockout all settings can be modified by anyone who knows how to find their way to the *SLoE* and *rLoE* parameters.

Using Lockout Method 2 (Password Enable)

It is sometimes desirable to apply a higher level of security to the control where a password would be required to access the control. If Password Enabled *PRSE* in the Factory Page under the *LoC* Menu is set to on, an overriding Password Security will be in effect. Without the appropriate password, specified menus will remain inaccessible. Page and Menu access is defined in the Locked Access Level *LoLL* prompt. On the other hand, a User with a password would have visibility restricted by the Read Lockout Security *rLoC*. As an example, with Password Enabled and the Locked Access Level *LoLL* set to 1 and *rLoC* is set to 3, the available Pages for a User without a password would be limited to the Home and Factory Pages (locked level 1). If the User password is entered all pages would be accessible with the exception of the Setup Page as defined by level 3 access.

How to Enable Password Security

Follow the steps below:

1. From the Home Page, press and hold the Infinity Key  and the Advance Key  for approximately six seconds. *CUSt* will appear in the red display and *FCEY* will appear in the green display.
2. Press the Up Key  until *LoC* appears in the red display and *FCEY* will appear in the green display.
3. Press the Advance Key  until Password Enable *PRSE* appears in the bottom display and change it to *5*.
4. Press the Up Key  to turn it *on*. Once on, four new prompts will appear:
 - a. **Locked Access Level** *LoLL*, (1 to 5) corresponding to the lockout table above.
 - b. **Rolling Password** *rOLL*, will change the Customer Code every time power is cycled.
 - c. **User Password** *PRSu*, which is needed for a User to acquire access to the control.
 - d. **Administrator Password** *PRSA*, which is needed to acquire administrative access to the control.

The Administrator can either change the User and or the Administrator password or leave them in the default state. Once Password Security is enabled they will no longer be visible to anyone other than the Administrator. In other words the Lock Menu *LoC* is not available to a User. As can be seen in the formula that follows either the User or Administrator will need to know what those passwords are to acquire a higher level of access to the control. Back out of this menu by pushing the Infinity Key . Once out of the menu, the Password Security will be enabled.

How to Acquire Access to the Control

To acquire access to any inaccessible Pages or Menus, go to the Factory Page and enter the *ULoC* menu. Once there follow the steps below:

Note:

If Password Security (Password Enabled *PRSE* is On) is enabled the two prompts mentioned below in the first step will not be visible. If the password is unknown, call the individual or company that originally setup the control.

1. Acquire either the User Password *PRSu* or the Administrator Password *PRSA*.
2. Press the Advance  key one time where the Code *Code* prompt will be visible.

Note:

- a. If the Rolling Password is off, press the Advance Key  one more time where the Pass-

word *PASS* prompt will be displayed. Proceed to either step 7a or 8a. Pushing the Up ▲ or Down ▼ arrow keys enter either the User or Administrator Password. Once entered, press and hold the Infinity Ⓢ key for two seconds to return to the Home Page.

b. If the Rolling Password *ROLL* was turned on proceed on through steps 3 - 9.

3. Assuming the Code *CODE* prompt (Public Key) is still visible on the face of the control simply push the Advance Key Ⓢ to proceed to the Password *PASS* prompt. If not, find your way back to the Factory Page as described above.
4. Execute the calculation defined below (7b or 8b) for either the User or Administrator.
5. Enter the result of the calculation in the upper display play by using the Up ▲ and Down ▼ arrow keys or use PM3 LEGACY™ PID Configurator Software.
6. Exit the Factory Page by pressing and holding the Infinity Key Ⓢ for two seconds.

Formulas used by the User and the Administrator to calculate the Password follows:

Passwords equal:

7. User

a. If Rolling Password *ROLL* is Off, Password *PASS* equals User Password *PASU*.

b. If Rolling Password *ROLL* is On, Password *PASS* equals: $(PASU \times code) \text{ Mod } 929 + 70$

8. Administrator

a. If Rolling Password *ROLL* is Off, Password *PASS* equals User Password *PASR*.

b. If Rolling Password *ROLL* is On, Password *PASS* equals: $(PASR \times code) \text{ Mod } 997 + 1000$

Differences Between a User Without Password, User With Password and Administrator

- User without a password is restricted by the Locked Access Level *LoL*.
- A User with a password is restricted by the Read Lockout Security *rLoL* never having access to the Lock Menu *LoL*.
- An Administrator is restricted according to the Read Lockout Security *rLoL* however, the Administrator has access to the Lock Menu where the Read Lockout can be changed.

Modbus - Using Programmable Memory Blocks

When using the Modbus RTU or Modbus TCP protocols, the PM control features a block of addresses that can be configured by the user to provide direct access to a list of 40 user configured parameters. This allows the user easy access to this customized list by reading from or writing to a contiguous block of registers.

To acquire a better understanding of the tables found in the back of this manual (See Appendix: *Modbus Programmable Memory Blocks*) please read through the text below which defines the column headers used.

Assembly Definition Addresses

- Fixed addresses used to define the parameter that will be stored in the "Working Addresses", which may also be referred to as a pointer. The value stored in these addresses will reflect (point to) the Modbus address of a parameter within the PM control.

Assembly Working Addresses

- Fixed addresses directly related to their associated "Assembly Definition Addresses" (i.e., Assembly Working Addresses 200 & 201 will assume the parameter pointed to by Assembly Definition Addresses 40 & 41).

When the Modbus address of a target parameter is stored in an "Assembly Definition Address" its corresponding working address will return that parameter's actual value. If it's a writable parameter, writing to its working register will change the parameter's actual value. As an example, Modbus register 360 represents the Analog Input 1 Process Value (See Operations Page, Analog Input Menu). If the value 360 is loaded into Assembly Definition Address 90 and value 361 is loaded into Assembly Definition Address 91, the process value sensed by analog input 1 will also be stored in Modbus registers 250 and 251. Notice that by default this parameter is also stored in working registers 240 and 241 as well.

Note:

When modifying the Modbus Assembly registers, single register writes (function 06) are not allowed. Multiple register writes (function 16) must be used to modify the assembly.

The table identified as "Assembly Definition Addresses and Assembly Working Addresses" (see Appendix: Modbus Programmable Memory Blocks) reflects the assemblies and their associated addresses.

Note:

Modbus allows a maximum of 125 16-bit registers to be read with one read command. That is 62 of the 32-bit registers defined here. Use two read commands to read the entire assembly if desired in one module. Each module has its own assembly and the assembly working addresses must be within the same module.

Software Configuration

Using PM3 LEGACY™ PID Configurator Software

To enable a user to configure the PM control using a personal computer (PC), Watlow has provided free software for your use. If you have not yet obtained a copy of this software insert the CD (Controller Support Tools) into your CD drive and install the software. Alternatively, if you are viewing this document electronically and have a connection to the internet simply click on the link below and download the software from the Watlow web site free of charge.

<http://www.watlow.com/en/resources-and-support/Technical-Library/Software-and-Demos>

Once the software is installed double click on the Configurator icon placed on your desktop during the installation process. If you cannot find the icon follow the steps below to run the software:

1. Move your mouse to the "Start" button
2. Place the mouse over "All Programs"
3. Navigate to the "Watlow" folder and then the sub-folder "Configurator"
4. Click on Configurator to run.

The first screen that will appear is shown here.



If the PC is already physically connected to the PM3 LEGACY™ PID control click the next button to go on-line.

Note:

When establishing communications from PC to the PM3 LEGACY™ PID control an interface converter will be required. The Standard Bus network uses EIA-485 as the interface. Most PCs today would require a USB to EIA-485 converter. However, some PCs may still be equipped with EIA-232 ports, therefore an EIA-232 to EIA-485 converter would be required.

As can be seen in the above screen shot the software provides the user with the option of downloading a previously saved configuration as well as the ability to create a configuration off-line to download later. The screen shots that follow will take the user on-line.

After clicking the next button above it is necessary to define the communications port that will be used on the PC as shown below. Clicking on the drop down will allow the user to select the appropriate communications port. This will be the port assigned to the EIA-485 to USB converter when it was connected to the PC. The "Advanced" button allows the user to determine how many devices to look for on the network (1 to 17).



After clicking on the "Next" button, the software will scan the network for the zone addresses specified while showing the progress made (as shown in the graphic below. When complete the software will display all of the available devices found on the network as shown below.

Searching Network for Devices

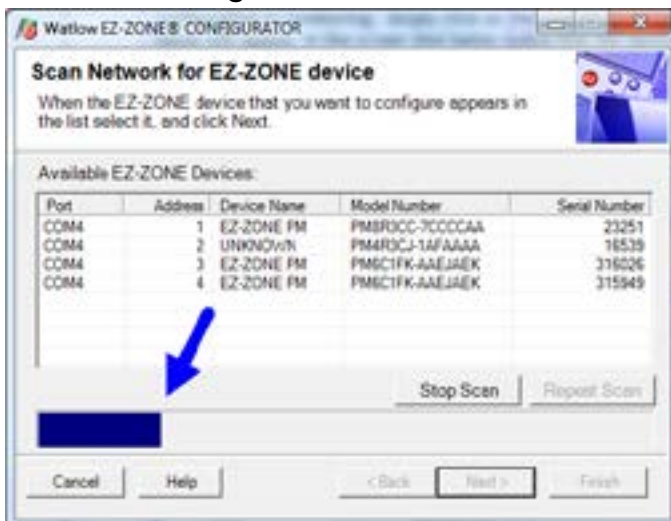

Available Network Devices Displayed

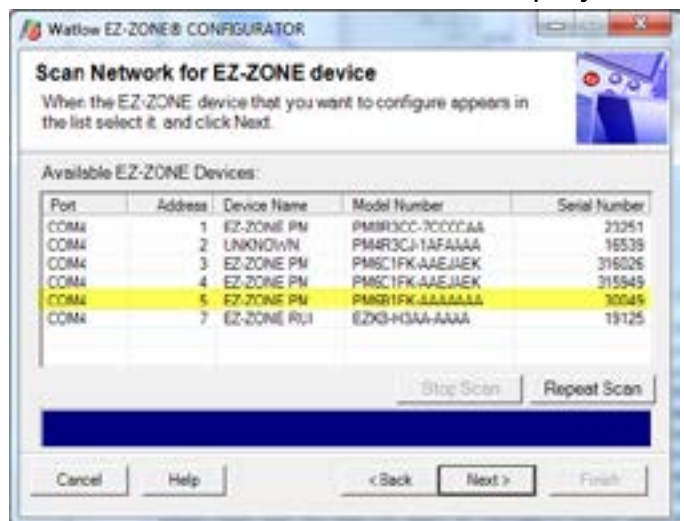

Any PM3 LEGACY™ PID device on the network will appear in this window and would be available for the purpose of configuration or monitoring; simply click on the control of choice. After doing so, the screen below will appear. In the screen shot below notice that the device part number is clearly displayed at the top of the page (yellow highlight added for emphasis). When multiple PM3 LEGACY™ PID devices are on the network it is important that the part number be noted prior to configuring so as to avoid making unwanted configuration changes to another control. Looking closely at the left hand column (Parameter Menus) notice that it displays all of the available menus and associated parameters within the control.

The menu structure as laid out within this software follows:

- Setup - Operations - Factory - Profile

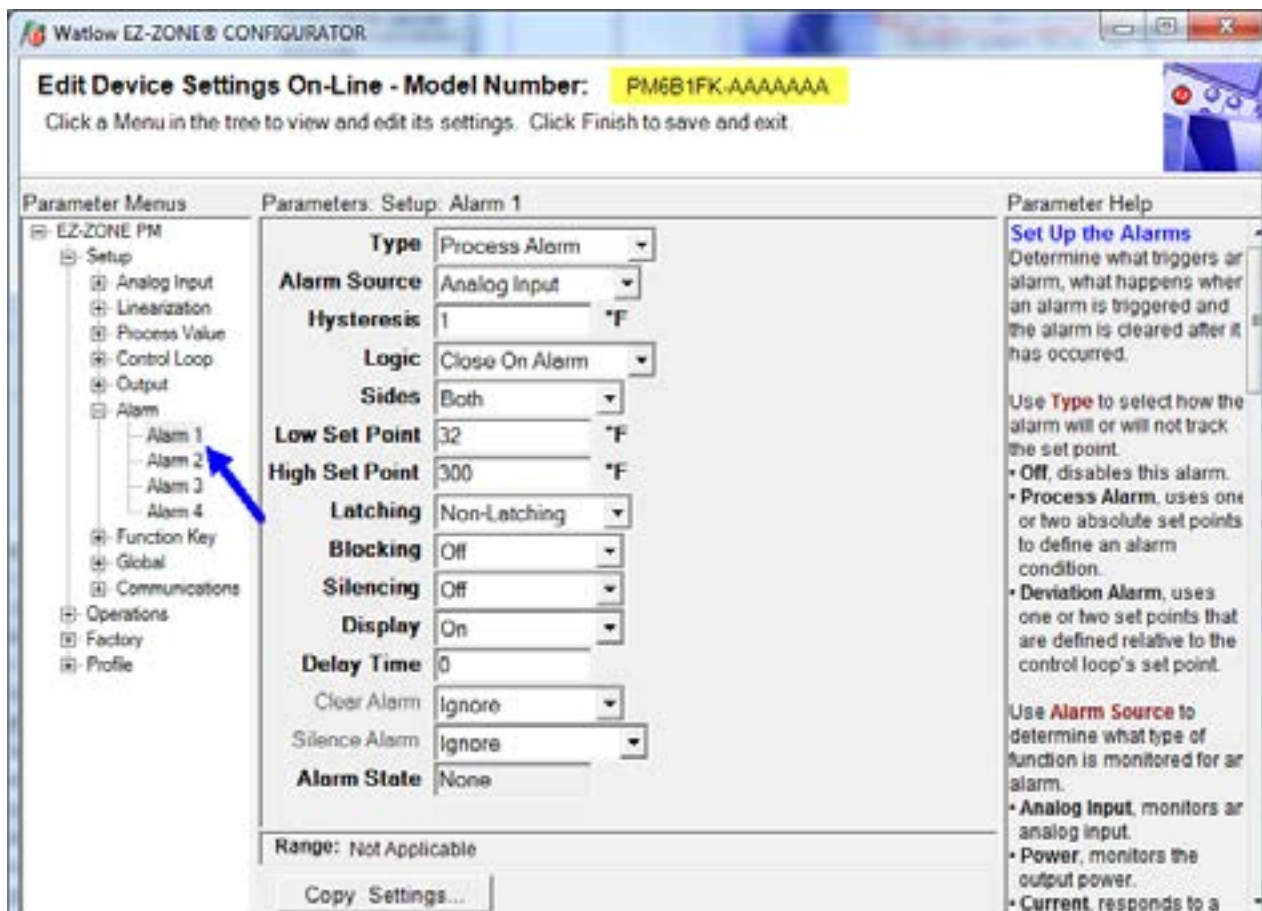

Navigating from one menu to the next is easy and clearly visible. Simply slide the scroll bar up or down to display the menu and parameter of choice. If there is a need to bring greater focus and clarity to the parameters of interest simply click on the negative symbol next to any of the Menu items. As an example if it is desired to work within the Operations page click the negative sign next to Setup where the Setup Page will then collapse. Now click the plus sign next to Operations to find the menu items of choice without viewing unwanted menus and parameters. Once the focus is brought to an individual parameter (single click of mouse) as is the case for Analog Input 1 in the left column; all that can be setup related to that parameter will appear in the center column. The grayed out fields in the center column simply mean that this does not apply for the type of sensor selected. As an example, notice that when a thermocouple is selected, RTD Leads does not apply and is therefore grayed out. To speed up the process of configuration, notice that at the bottom of the center column there is an option to copy settings. If all alarms were to be setup the same click on "Copy Settings" where a copy dialog box will appear allowing for quick duplication of all settings. Notice too, that by click-

ing on any of those items in the center column that context sensitive help will appear for that particular item in the right hand column.

Lastly, when the configuration is complete click the "Finish" button at the bottom right of the previous screen shot. The screen that follows this action can be seen below.



Although the PM control now contains the configuration (because the previous discussion focused on doing the configuration on-line) it is suggested that after the configuration process is completed that the user save this file on the PC for future use. If for some reason someone inadvertently changed a setting without understanding the impact, it would be easy and perhaps faster to download a saved configuration back to the control versus trying to figure out what was changed. Of course, there is an option to exit without saving a copy to the local hard drive. After selecting Save above, click the "Finish" button once again. The screen below will then appear. When saving the configuration, note the location where the file will be placed (saved in) and enter the file name (File name) as well. The default path for saved files follows:

The user can save the file to any folder of choice.

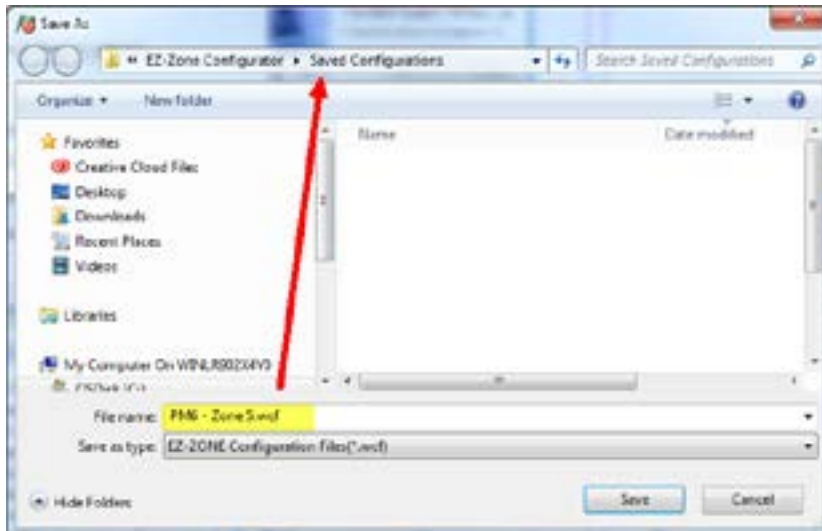

10

Chapter 10: Appendix

Troubleshooting Alarms, Errors and Control Issues

Indication	Description	Possible Cause(s)	Corrective Action
Alarm won't clear or reset	Alarm will not clear or reset with keypad or digital input	<ul style="list-style-type: none"> • Latching is active • Alarm set to incorrect output • Alarm is set to incorrect source • Sensor input is out of alarm set point range • Alarm set point is incorrect • Alarm is set to incorrect type • Digital input function is incorrect 	<ul style="list-style-type: none"> • Reset alarm when process is within range or disable latching • Set output to correct alarm source instance • Set alarm source to correct input instance • Correct cause of sensor input out of alarm range • Set alarm set point to correct trip point • Set alarm to correct type: process, deviation or power • Set digital input function and source instance
Alarm won't occur	Alarm will not activate output	<ul style="list-style-type: none"> • Silencing is active • Blocking is active • Alarm is set to incorrect output • Alarm is set to incorrect source • Alarm set point is incorrect • Alarm is set to incorrect type 	<ul style="list-style-type: none"> • Disable silencing, if required • Disable blocking, if required • Set output to correct alarm source instance • Set alarm source to correct input instance • Set alarm set point to correct trip point • Set alarm to correct type: process, deviation or power
Alarm Error <i>ALE1</i> <i>ALE2</i> <i>ALE3</i> <i>ALE4</i>	Alarm state cannot be determined due to lack of sensor input	<ul style="list-style-type: none"> • Sensor improperly wired or open • Incorrect setting of sensor type • Calibration corrupt 	<ul style="list-style-type: none"> • Correct wiring or replace sensor • Match setting to sensor used • Check calibration of controller

Indication	Description	Possible Cause(s)	Corrective Action
Alarm Low <i>ALL1</i> <i>ALL2</i> <i>ALL3</i> <i>ALL4</i>	Sensor input below low alarm set point	<ul style="list-style-type: none"> • Temperature is less than alarm set point • Alarm is set to latching and an alarm occurred in the past • Incorrect alarm set point • Incorrect alarm source 	<ul style="list-style-type: none"> • Check cause of under temperature • Clear latched alarm • Establish correct alarm set point • Set alarm source to proper setting
Alarm High <i>ALH1</i> <i>ALH2</i> <i>ALH3</i> <i>ALH4</i>	Sensor input above high alarm set point	<ul style="list-style-type: none"> • Temperature is greater than alarm set point • Alarm is set to latching and an alarm occurred in the past • Incorrect alarm set point • Incorrect alarm source 	<ul style="list-style-type: none"> • Check cause of over temperature • Clear latched alarm • Establish correct alarm set point • Set alarm source to proper setting
Error Input <i>Err1</i>	Sensor does not provide a valid signal to controller	<ul style="list-style-type: none"> • Sensor improperly wired or open • Incorrect setting of sensor type • Calibration corrupt 	<ul style="list-style-type: none"> • Correct wiring or replace sensor • Match setting to sensor used • Check calibration of controller
Ambient Error <i>ErrAb</i>	Sensor does not provide a valid signal to controller	<ul style="list-style-type: none"> • Ambient error - cold junction circuitry not working 	<ul style="list-style-type: none"> • Return to factory for repair
Loop Open Error <i>LPo1</i>	Open Loop Detect is active and the process value did not deviate by a user-selected value in a user specified period with PID power at 100%.	<ul style="list-style-type: none"> • Setting of Open Loop Detect Time incorrect • Setting of Open Loop Detect Deviation incorrect • Thermal loop is open • Open Loop Detect function not required but activated 	<ul style="list-style-type: none"> • Set correct Open Loop Detect Time for application • Set correct Open Loop Deviation value for application • Determine cause of open thermal loop: misplaced sensors, load failure, loss of power to load, etc. • Deactivate Open Loop Detect feature

Indication	Description	Possible Cause(s)	Corrective Action
Loop Reversed Error <i>LP r I</i>	Open Loop Detect is active and the process value is headed in the wrong direction when the output is activated based on deviation value and user-selected value.	<ul style="list-style-type: none"> • Setting of Open Loop Detect Time incorrect • Setting of Open Loop Detect Deviation incorrect • Output programmed for incorrect function • Thermocouple sensor wired in reverse polarity 	<ul style="list-style-type: none"> • Set correct Open Loop Detect Time for application • Set correct Open Loop Deviation value for application • Set output function correctly • Wire thermocouple correctly, (red wire is negative)
Ramping <i>r P I</i>	Controller is ramping to new set point	<ul style="list-style-type: none"> • Ramping feature is activated 	<ul style="list-style-type: none"> • Disable ramping feature if not required
Autotuning <i>t U n I</i>	Controller is autotuning the control loop	<ul style="list-style-type: none"> • User started the autotune function • Digital input is set to start autotune 	<ul style="list-style-type: none"> • Wait until autotune completes or disable autotune feature • Set digital input to function other than autotune, if desired
No heat/cool action	Output does not activate load	<ul style="list-style-type: none"> • Output function is incorrectly set • Control mode is incorrectly set • Output is incorrectly wired • Load, power or fuse is open • Control set point is incorrect • Incorrect controller model for application 	<ul style="list-style-type: none"> • Set output function correctly • Set control mode appropriately (Open vs Closed Loop) • Correct output wiring • Correct fault in system • Set control set point in appropriate control mode and check source of set point: remote, idle, profile, closed loop, open loop • Obtain correct controller model for application

Indication	Description	Possible Cause(s)	Corrective Action
No Display	No display indication or LED illumination	<ul style="list-style-type: none"> • Power to controller is off • Fuse open • Breaker tripped • Safety interlock switch open • Separate system limit control activated • Wiring error • Incorrect voltage to controller 	<ul style="list-style-type: none"> • Turn on power • Replace fuse • Reset breaker • Close interlock switch • Reset limit • Correct wiring issue • Apply correct voltage, check part number
No Serial Communication	Cannot establish serial communications with the controller	<ul style="list-style-type: none"> • Address parameter incorrect • Incorrect protocol selected • Baud rate incorrect • Parity incorrect • Wiring error • EIA-485 converter issue • Incorrect computer or PLC communications port • Incorrect software setup • Wires routed with power cables • Termination resistor may be required 	<ul style="list-style-type: none"> • Set unique addresses on network • Match protocol between devices • Match baud rate between devices • Match parity between devices • Correct wiring issue • Check settings or replace converter • Set correct communication port • Correct software setup to match controller • Route communications wires away from power wires • Place 120 Ω resistor across EIA-485 on last controller
Process doesn't control to set point	Process is unstable or never reaches set point	<ul style="list-style-type: none"> • Controller not tuned correctly • Control mode is incorrectly set • Control set point is incorrect 	<ul style="list-style-type: none"> • Perform autotune or manually tune system • Set control mode appropriately (Open vs Closed Loop) • Set control set point in appropriate control mode and check source of set point: remote, idle, profile, closed loop, open loop

Indication	Description	Possible Cause(s)	Corrective Action
Temperature runaway	Process value continues to increase or decrease past set point.	<ul style="list-style-type: none"> • Controller output incorrectly programmed • Thermocouple reverse wired • Controller output wired incorrectly • Short in heater • Power controller connection to controller defective • Controller output defective 	<ul style="list-style-type: none"> • Verify output function is correct (heat or cool) • Correct sensor wiring (red wire negative) • Verify and correct wiring • Replace heater • Replace or repair power controller • Replace or repair controller
Device Error <i>100</i> <i>rErrn</i>	Controller displays internal malfunction message at power up.	<ul style="list-style-type: none"> • Controller defective • Sensor input over driven 	<ul style="list-style-type: none"> • Replace or repair controller • Check sensors for ground loops, reverse wiring or out of range values.
Menus inaccessible	Unable to access <i>SEt</i> , <i>oPEr</i> , <i>FLtY</i> or <i>PrOF</i> menus or particular prompts in Home Page	<ul style="list-style-type: none"> • Security set to incorrect level • Digital input set to lock-out keypad • Custom parameters incorrect 	<ul style="list-style-type: none"> • Check <i>LoE</i> settings in Factory Page and enter appropriate password in <i>ULoE</i> setting in Factory Page • Change state of digital input • Change custom parameters in Factory Page
Displayed value to low <i>uALL</i>	Value to low to be displayed in 4 digit LED display <-1999	<ul style="list-style-type: none"> • Incorrect setup 	<ul style="list-style-type: none"> • Check scaling of source data
Displayed value to high <i>uALh</i>	Value to high to be displayed in 4 digit LED display >9999	<ul style="list-style-type: none"> • Incorrect setup 	<ul style="list-style-type: none"> • Check scaling of source data

Detection of and Rules Around Abnormal Sensor Conditions	
Inputs	Detection of Abnormal Conditions
Thermocouple	
Shorted	No direct detection, Open loop firmware detection.
Open	Yes, Parasitic pull-up
Reversed	Yes, firmware detection
Current Source	
Shorted	Range limiting only
Open	Range limiting only
Reversed	Range limiting only

Voltage Source	
Open	Range limiting only
Shorted	Range limiting only
Reversed	Range limiting only
RTD	
S1 open	Yes, pulled up.
S2 open	Not implemented.
S3 open	Yes, pulled up.
S1 short to S2	Yes, pulled up
S1 short to S3	Yes, pulled down to under range.
S2 shorted to S3	Not implemented, Possible, monitor S2 voltage.
S1 and S2 open	Yes, pulled down to under range.
S1 and S3 open	Yes, S1 pulled up.
S2 and S3 open	Yes pulled up.
Thermistor	
S1 open	Yes, pulled up to sensor over range.
S3 open	Yes, pulled up to sensor over range.
S1 short to S3	Yes, pulled down to sensor under range.
S1 and S3 open	Yes, S1 pulled up to sensor over range.

Modbus - Programmable Memory Blocks

The Modbus assembly or programmable memory blocks consists of 80 pointers to the parameters of your choosing starting at Modbus register 80 (shown on the following page). The pointers are 32-bits long and are stored in two sequential registers. As an example, if it is desired to move an alias to the Set Point of the PM (register 2160) into pointer registers 40 and 41, a single multi-write command (0x10 function) would be used writing 2160 into register 40 and 2161 into register 41.

Once the parameters of choice have been defined and written to the specified pointer registers, the working registers will then represent the parameters written. In the example above, the 32-bit floating point Set Point (2160 and 2161) was first written to registers 40 and 41 which in turn defines working registers 200 and 201 as Set Point. As can be seen in the graphic below, reading back registers 200 and 201 the Set Point is displayed.

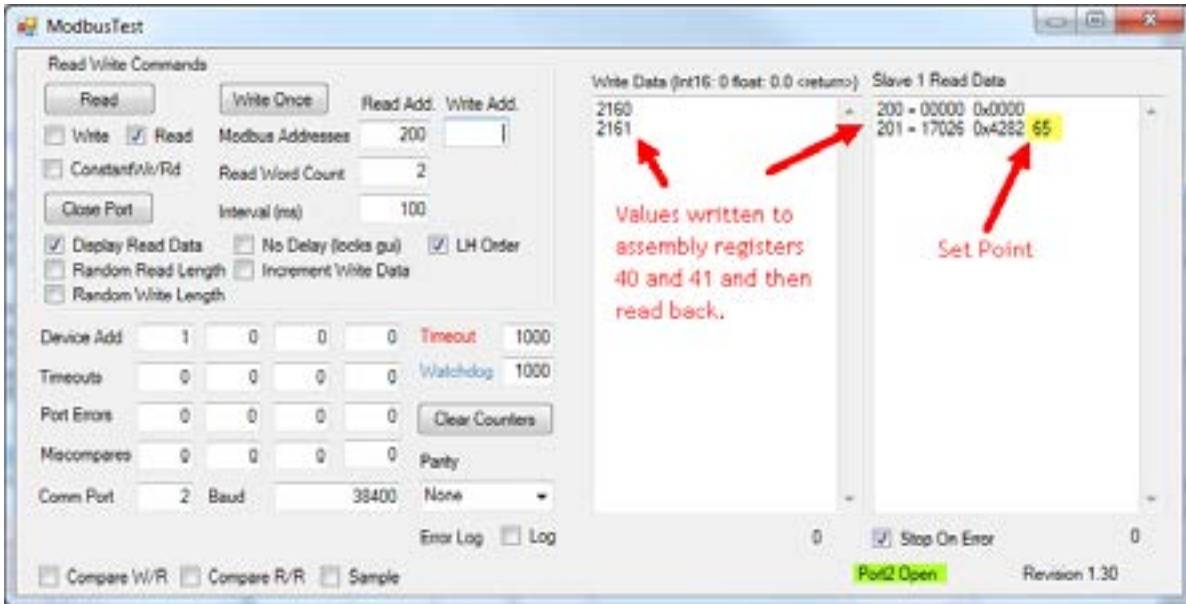

The screen shot above was taken from a program that can be found on the Watlow Support Tools DVD (shipped with the product) as well as on the Watlow website. On the DVD, it can be found under "Utility Tools" and is identified as "Modbus RTU Diagnostic Program for PM3 LEGACY™ PID, RM and ST". A similar program can be found here as well for Modbus TCP. If it is easier to go to the web to acquire this software, click on the link below and type "modbus" in the search field where both versions can be found and downloaded. <http://www.watlow.com/en/Resources-And-Support/Technical-Library/Software-and-Demos>

Assembly Definition Addresses and Assembly Working Addresses

Pointer Registers	Working Registers
40 & 41	200 & 201
42 & 43	202 & 203
44 & 45	204 & 205
46 & 47	206 & 207
48 & 49	208 & 209
50 & 51	210 & 211
52 & 53	212 & 213
54 & 55	214 & 215
56 & 57	216 & 217
58 & 59	218 & 219
60 & 61	220 & 221
62 & 63	222 & 223
64 & 65	224 & 225
66 & 67	226 & 227
68 & 69	228 & 229
70 & 71	230 & 231
72 & 73	232 & 233
74 & 75	234 & 235
76 & 77	236 & 237
78 & 79	238 & 239
80 & 81	240 & 241
82 & 83	242 & 243
84 & 85	244 & 245
86 & 87	246 & 247
88 & 89	248 & 249
90 & 91	250 & 251
92 & 93	252 & 253
94 & 95	254 & 255
96 & 97	256 & 257
98 & 99	256 & 259
100 & 101	260 & 261
102 & 103	262 & 263
104 & 105	264 & 265
106 & 107	266 & 267
108 & 109	268 & 269
110 & 111	270 & 271
112 & 113	272 & 273
114 & 115	274 & 275
116 & 117	276 & 277
118 & 119	278 & 279

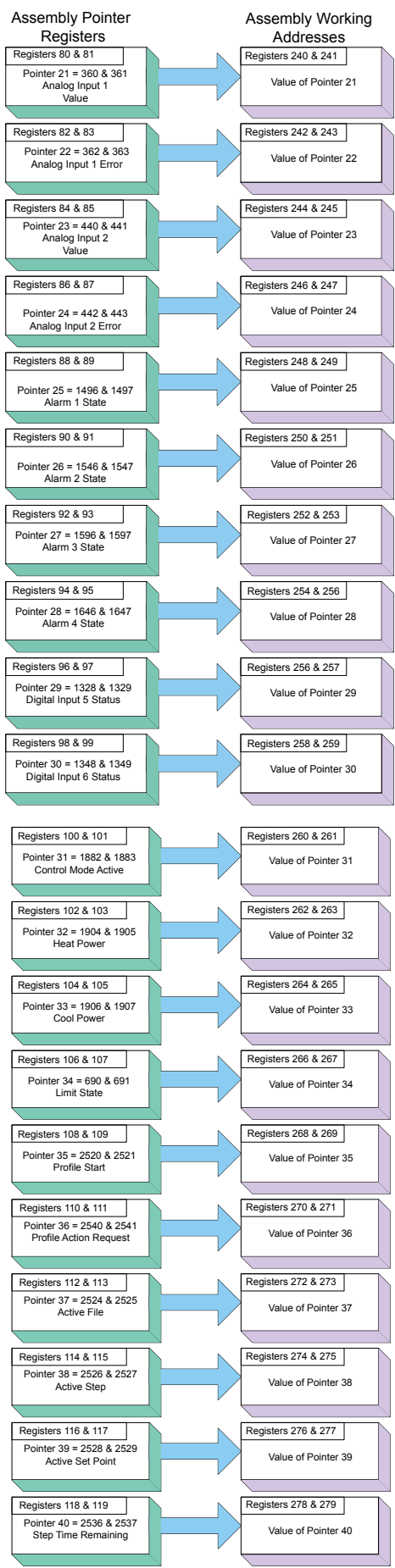
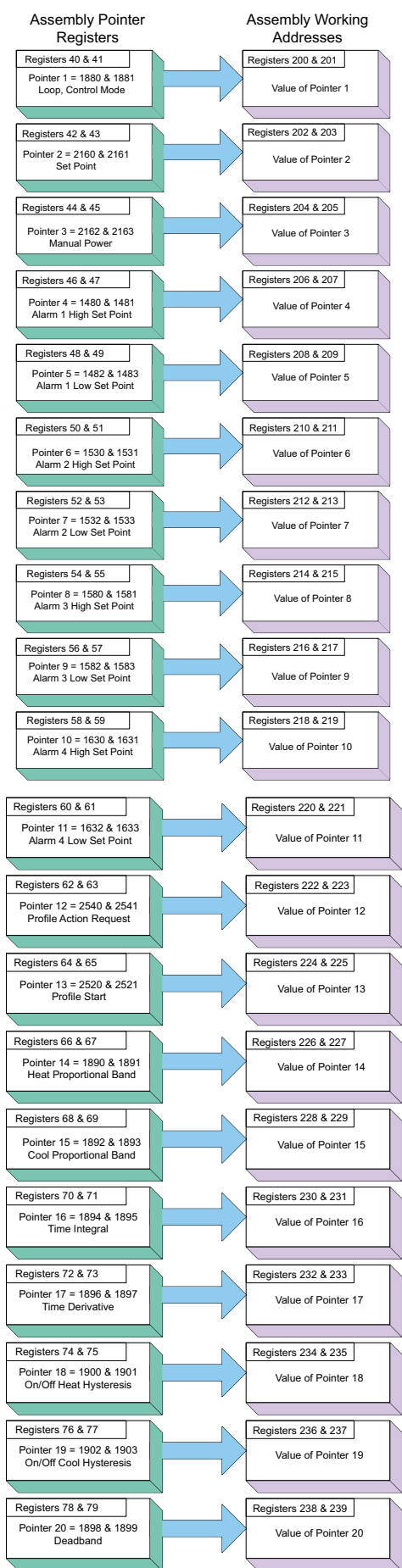

PM Specifications

LineVoltage/Power (Minimum/Maximum Ratings)

- 85 to 264V~ (ac), 47 to 63Hz
- 20 to 28V~ (ac), 47 to 63Hz
- 12 to 40V= (dc)
- 10VA maximum power consumption
- Data retention upon power failure via non-volatile memory
- Compliant with SEMIF47-0200, Figure R1-1 voltage sag requirements @ 24V~ (ac) or higher

Environment

- 0 to 149°F (-18 to 65°C) operating temperature
- -40 to 185°F (-40 to 85°C) storage temperature
- 0 to 90% RH, non-condensing

Accuracy

- Calibration accuracy and sensor conformity: $\pm 0.1\%$ of span, $\pm 1^{\circ}\text{C}$ @ the calibrated ambient temperature and rated line voltage
- Types R, S, B; 0.2%
- Type T below -50°C ; 0.2%
- Calibration ambient temperature @ $77 \pm 5^{\circ}\text{F}$ ($25 \pm 3^{\circ}\text{C}$)
- Accuracy span :1000 °F (540°C) min.
- Temperature stability: ± 0.1 °F/°F ($\pm 0.1^{\circ}\text{C}/^{\circ}\text{C}$) rise in ambient max.

Agency Approvals

- UL® Listed to UL 61010-1 File E185611
- UL Reviewed to CSA C22.2 No.61010-1-04
- UL 50 Type 4X, NEMA 4X indoor locations, IP65 front panel seal (indoor use only)
- FM Class 3545 File 3029084 temperature limit switches
- CE-See Declaration of Conformity RoHS and W.E.E.E. complaint
- UL Listed to ANSI/ISA 12.12.01-2007 File E184390
- This equipment is suitable for use in Class 1, Div.2, Groups A, B, C and D or non-hazardous locations only. Temperature Code T4A
- UL reviewed to Standard No. CSA C22.2 No.213-M1987, Canadian Hazardous locations
- All models, CSA C22.2 No. 24 File 158031 Class 4813-02, CSA Approved
- Connects quickly and easily via Bluetooth® wireless communications

Controller

- User selectable heat/cool, on-off, P, PI, PD, PID or alarm action
- Auto-tune with TRU-TUNE®+ adaptive control algorithm
- Control sampling rates: input = 10Hz, outputs = 10Hz

Profile Ramp/Soak

- Accuracy (typical): $\pm 30\text{PPM}$ at 77°F (25°C)
- $+30/-100$ PPM at -4 to 149°F (-20 to 65°C)

Isolated Serial Communications

- EIA232/485, Modbus® RTU

Wiring Termination – Touch-Safe Terminals

- Input, power and controller output terminals are touch safe removable 3.30 to 0.0507 mm² (12 to 22 AWG)
- Wire strip length 7.6 mm (0.30 in.)
- Torque 0.56 Nm (5.0 in-lb)

Universal Input

- Thermocouple, grounded or ungrounded sensors
 - >20MΩ input impedance
- Max. 2kΩ source resistance
- 3μA open sensor detection
- RTD 2- or 3-wire, platinum, 100Ω and 1kΩ @ 0°C (32°F) calibration to DIN curve (0.00385 Ω/Ω/°C)
- Process, 0-20mA @100Ω, or 0-10V (dc) @ 20kΩ input impedance; scalable, 0-50mV

Voltage Input Ranges

- Accuracy ±10mV ±1 LSD at standard conditions
- Temperature stability ±100 PPM/°C maximum

Milliamp Input Ranges

- Accuracy ±20μA ±1 LSD at standard conditions
- Temperature stability ±100 PPM/°C maximum

Resolution Input Ranges

- 0 to 10V: 200μV nominal
- 0 to 20 mA: 0.4uA nominal

- Potentiometer: 0 to 1.2kΩ
- Inverse scaling

Input Type	Max Error @ 25 Deg C	Accuracy Range Low	Accuracy Range High	Units
J	±1.75	0	750	Deg C
K	±2.45	-200	1250	Deg C
T	±1.55	-200	350	Deg C
N	±2.25	0	1250	Deg C
E	±2.10	-200	900	Deg C
R	±3.9	0	1450	Deg C
S	±3.9	0	1450	Deg C
B	±2.66	870	1700	Deg C
C	±3.32	0	2315	Deg C
D	±3.32	0	2315	Deg C
F (PTII)	±2.34	0	1343	Deg C
RTD, 100 ohm	±2.00	-200	800	Deg C
RTD, 1000 ohm	±2.00	-200	800	DegC
mV	±0.05	-50	50	mV

Input Type	Max Error @ 25 Deg C	Accuracy Range Low	Accuracy Range High	Units
Volts	±0.01	0	10	Volts
mAdc	±0.02	0	20	mAmps DC
mAac	±5	0	50	mAmps AC

Operating Range			
Input Type	Range Low	Range High	Units
J	-210	1200	Deg C
K	-270	1371	Deg C
T	-270	400	Deg C
N	-270	1300	Deg C
E	-270	1000	Deg C
R	-50	1767	Deg C
S	-50	1767	Deg C
B	0	1816	Deg C
C	0	2315	Deg C
D	0	2315	Deg C
F (PTII)	0	1343	Deg C
RTD (100 ohm)	-200	800	Deg C
RTD (1000 ohm)	-200	800	Deg C
mV	0	50	mV
Volts	0	10	Volts
mAdc	0	20	mAmps DC
mAac	0	50	mAmps AC
Potentiometer, 1K range	0	1200	Ohms
Resistance, 5K range	0	5000	Ohms
Resistance, 10K range	0	10000	Ohms
Resistance, 20K range	0	20000	Ohms
Resistance, 40K range	0	40000	Ohms

Thermistor Input				
Input Type	Max Error @ 25 Deg C	Accuracy Range Low	Accuracy Range High	Units
Thermistor, 5K range	±5	0	5000	Ohms
Thermistor, 10K range	±10	0	10000	Ohms
Thermistor, 20K range	±20	0	20000	Ohms
Thermistor, 40K range	±40	0	40000	Ohms

- 0 to 40kΩ, 0 to 20kΩ, 0 to 10kΩ, 0 to 5kΩ
- 2.252kΩ and 10kΩ base at 25°C

- Linearization curves built in
- Third party Thermistor compatibility requirements

Base R @ 25C	Alpha Techniques	Beta THERM	YSI	Thermistor Curve
2.252K	Curve A	2.2K3A	004	A
10K	Curve A	10K3A	016	B
10K	Curve C	10K4A	006	C

2 Digital Input/Output Option - 2 DIO

- Digital input update rate 10Hz
 - DC voltage
 - Max. input 36V @ 3mA
 - Min. high state 3V at 0.25mA
 - Max. low state 2V
 - Dry contact
 - Min. open resistance 10k Ω
 - Max. closed resistance 50 Ω
 - Max. short circuit 13mA
- Digital output update rate 10Hz
 - SSR drive signal
 - Update rate 10 Hz
 - Maximum open circuit voltage is 22 to 25 \approx (dc)
 - PNP transistor source
 - Typical drive; 21mA @ 4.5V for DO5, and 11mA @ 4.5V for DO6
 - Current limit 24mA for Output 5 and 12mA Output 6
 - Output 5 capable of driving one 3 - pole DIN-A-MITE
 - Output 6 capable of driving one 1 - pole DIN-A-MITE

Output Hardware

- Switched DC
 - Maximum open circuit voltage is 22 to 25V \approx (dc)
 - 30mA max. per single output / 40mA max. total per paired outputs (1 & 2, 3 & 4)
 - Typical drive; 4.5V \approx (dc) @ 30mA
 - Short circuit limited to <50mA
 - Use dc- and dc+ to drive external solid-state relay
 - 1-pole DIN-A-MITE: up to 4 in parallel or 4 in series
 - 2-pole DIN-A-MITE: up to 2 in parallel or 2 in series
 - 3-pole DIN-A-MITE: up to 2 in series

- Switched dc/open collector = 30V $\overline{=}$ (dc) max. @ 100mA max. current sink
- Solid State Relay (SSR), FormA, 0.5A @ 24V \sim (ac) min., 240V \sim (ac) max., 1A at 50°F linear derating to 0.5A at 149°F resistive, opto-isolated, without contact suppression, 120/240V \sim (ac) 20 VA pilot duty
- Minimum holding current of 10mA
- Electromechanical relay, Form C, 5A, 24 to 240V \sim (ac) or 30V $\overline{=}$ (dc) max., resistive load, 100,000 cycles at rated load, 125 VA pilot duty at 120/240V \sim (ac), 25 VA at 24V \sim (ac)
- Electromechanical relay, Form A, 5A, 24 to 240V \sim (ac) or 30V $\overline{=}$ (dc) max., resistive load, 100,000 cycles at rated load, 125 VA pilot duty at 120/240V \sim (ac), 25 VA at 24V \sim (ac)
- Universal process/retransmit, Output range selectable:
 - 0 to 10V $\overline{=}$ (dc) into a min. 1k Ω load
 - 0 to 20mA into max. 800 Ω load

Resolution

- dc ranges: 2.5mV nominal
- mA ranges: 5 μ A nominal

Calibration Accuracy

- dc ranges: \pm 15mV
- mA ranges: \pm 30 μ A

Temperature Stability

- 100 ppm/ $^{\circ}$ C

Operator Interface

- Dual 4 digit, 7 segment LED displays
- Advance, infinity, up and down keys
- Typical display update rate 1Hz

Dimensions				
Size	Behind Panel (max.)	Width	Height	Display Character Height
1/32	101.6 mm (4.00 in)	53.3 mm (2.10 in)	30.9 mm (1.22 in)	Large: 7.62 mm (0.300 in) Small: 5.59 mm (0.220 in)

Weight
1/32 DIN (PM3) <ul style="list-style-type: none"> • Controller: 127 g (4.5 oz.)

Modbus $^{\circledR}$ is a trademark of AEG Schneider Automation Inc.

UL $^{\circledR}$ is a registered trademark of Underwriters Laboratories Inc.

Note:

These specifications are subject to change without prior notice.

Ordering Information for PID Controller Models

CONTROLLER

LEGACY™ PID Controller Models
 TRU-TUNE+® Adaptive Tune, red-green 7-segment displays

PM3

-

AAA

PACKAGE SIZE

3 Panel Mount 1/32 DIN

PRIMARY FUNCTION

C PID Controller with Universal Input
 J PID Controller with Thermistor Input
 N PID Controller with Thermistor Input and Profiling Ramp and Soak
 R PID Controller with Universal Input and Profiling Ramp and Soak
 S Custom Firmware
 T PID Controller with Universal Input and Timer

POWER SUPPLY, DIGITAL INPUT/OUTPUT

1 100 to 240V (ac)
 2 100 to 240V (ac) plus 2 Digital I/O points
 3 15 to 36V (dc) and 24V (ac)
 4 15 to 36V (dc) and 24V (ac), plus 2 Digital I/O points

OUTPUT 1 AND 2 HARDWARE OPTIONS

	Output 1	Output 2
CA	Switched dc/open collector	None
CC	Switched dc/open collector	Switched dc
CJ	Switched dc/open collector	Mechanical relay 5 A, form A
CK	Switched dc/open collector	Solid-State Relay 0.5 A, form A
EA	Mechanical relay 5 A, form C	None
EC	Mechanical relay 5 A, form C	Switched dc
EJ	Mechanical relay 5 A, form C	Mechanical relay 5 A, form A
EK	Mechanical relay 5 A, form C	Solid-State Relay 0.5 A, form A
FA	Universal process	None
FC	Universal process	Switched dc (cannot use variable time base)
FJ	Universal process	Mechanical relay 5 A, form A (cannot use variable time base)
FK	Universal process	Solid-State Relay 0.5 A, form A (cannot use variable time base)
AK	None	Solid-State Relay 0.5 A, form A
KK	Solid-State Relay 0.5 A, form A	Solid-state relay 0.5 A, form A

- Options CH, EH and KH are not available with PM3 (1/32 DIN)

COMMUNICATIONS OPTIONS

A None
 1 EIA 485 Modbus RTU®
 B Bluetooth
 E EIA 485 Modbus RTU® Bluetooth
 - Standard Bus EIA-485 always included - all models

MODEL SELECTION

N PM LEGACY Version (Input 1 always Isolated)
 H PM LEGACY EXPRESS Version (Input 1 always Isolated)

CUSTOM OPTIONS

WP Standard LEGACY™ face plate
 12 Class 1, Div. 2 (Not available with mechanical relay output types E, H, J)
 WN No logo and no Watlow name
 AG Conformal coating
 XX Custom firmware, overlays, parameter settings



Declaration of Conformity

Series EZ-ZONE® PM



WATLOW Electric Manufacturing Company

1241 Bundy Blvd.
Winona, MN 55987 USA

Declares that the following product:

- Designation: **Series EZ-ZONE® PM (Panel Mount)**
- Model Numbers: PM (3, 6, 8, 9 or 4)(Any Letter or number)(1, 2, 3 or 4)(A, C, E, F or K) (A, C, H, J or K) – (Any letter or number)(Any letter or number)(A, C, E, F or K)(A, C, H, J or K) (Any three letters or numbers)
- Classification: Temperature control, Installation Category II, Pollution degree 2, IP65
- Rated Voltage and Frequency: 100 to 240 V~ (ac 50/60 Hz) **or** 15 to 36 V=dc/ 24 V~ac 50/60 Hz
- Rated Power Consumption: 10 VA maximum PM3, PM6 Models.
14 VA maximum PM8, PM9, PM4 Models

Meets the essential requirements of the following European Union Directives by using the relevant standards show below to indicate compliance.

2014/30/EU Electromagnetic Compatibility Directive

EN 61326-1:2013 Electrical equipment for measurement, control and laboratory use – EMC requirements (Industrial Immunity, Class A Emissions).

- IEC 61000-4-2:2008 Electrostatic discharge immunity
- IEC 61000-4-3:2007 Radiated, radio-frequency electromagnetic field immunity 10V/M 80–1000 MHz, 3 V/M 1.4–2.7 GHz
- +A1/2008, A2/2010
- IEC 61000-4-4:2012 Electrical fast-transient / burst immunity
- IEC 61000-4-5:2014 Surge immunity
- +A1/2017
- IEC 61000-4-6:2013 + Immunity to conducted disturbances induced by radio-frequency fields
- Corrigendum 2015
- IEC 61000-4-11:2020 Voltage dips, short interruptions and voltage variations immunity
- EN 61000-3-2:2014 Limits for harmonic current emissions for equipment ≤ 16 Amps per phase
- EN 61000-3-3¹:2013 + Voltage fluctuations and flicker ≤ 16 Amps per phase
- A1/2017
- SEMI F47-0812 Specification for semiconductor sag immunity Figure R1-1

¹For mechanical relay loads, cycle time may need to be extended up to 160 seconds to meet flicker requirements depending on load switched and source impedance.

Use in commercial or residential applications may require additional filtering to pass Class B emissions levels, system testing should be done to confirm.

2014/35/EU Low-Voltage Directive

EN 61010-1:2010² Safety Requirements of electrical equipment for measurement, control and laboratory use. Part 1: General requirements

² Compliance with 3rd Edition requirements with use of external surge suppressor installed on 230 Vac~ power line units. Recommend minimum 1000 V peak to maximum 2000 V peak, 70 joules or better part be used.

Compliant with 2011/65/EU RoHS2 Directive

Per 2012/19/EU W.E.E Directive  Please Recycle Properly.

Models PM(4, 8 or 9)E contain a type BR1225 coin cell battery which shall be recycled at end of life per 2006/66/EC Battery Directive as amended by 2013/56/EU Directive.

CE DOC EZ-ZONE PM-01-21

How to Reach Us

Corporate Headquarters

Watlow Electric Manufacturing Company
12001 Lackland Road
St. Louis, MO 63146
Sales: 1-800-WATLOW2
Manufacturing Support:
1-800-4WATLOW
Email: info@watlow.com
Website: www.watlow.com
From outside the USA and Canada:
Tel: +1 (314) 878-4600
Fax: +1 (314) 878-6814

Latin America

Watlow de México S.A. de C.V.
Av. Fundación No. 5
Col. Parques Industriales
Querétaro, Qro. CP-76130
Mexico
Tel: +52 442 217-6235
Fax: +52 442 217-6403

Europe

Watlow France
Tour d'Asnières.
4 Avenue Laurent Cély
92600 Asnières sur Seine
France
Tél: + 33 (0)1 41 32 79 70
Télécopie: + 33(0)1 47 33 36 57
Email: info@watlow.fr
Website: www.watlow.fr

Watlow GmbH
Postfach 11 65, Lauchwasenstr. 1
D-76709 Kronau
Germany
Tel: +49 (0) 7253 9400-0
Fax: +49 (0) 7253 9400-900
Email: info@watlow.de
Website: www.watlow.de

Watlow Italy S.r.l.
Viale Italia 52/54
20094 Corsico MI
Italy
Tel: +39 024588841
Fax: +39 0245869954
Email: italyinfo@watlow.com
Website: www.watlow.it

Watlow Ibérica, S.L.U.
C/Marte 12, Posterior, Local 9
E-28850 Torrejón de Ardoz
Madrid - Spain
T. +34 91 675 12 92
F. +34 91 648 73 80
Email: info@watlow.es
Website: www.watlow.es

Watlow UK Ltd.
Linby Industrial Estate
Linby, Nottingham, NG15 8AA
United Kingdom
Telephone: (0) 115 964 0777
Fax: (0) 115 964 0071
Email: info@watlow.co.uk
Website: www.watlow.co.uk
From outside The United Kingdom:
Tel: +44 115 964 0777
Fax: +44 115 964 0071

Asia and Pacific

Watlow Singapore Pte Ltd.
16 Ayer Rajah Crescent,
#06-03/04,
Singapore 139965
Tel: +65 6773 9488 Fax: +65 6778 0323
Email: info@watlow.com.sg Website: www.watlow.com.sg

Watlow Australia Pty., Ltd.
4/57 Sharps Road
Tullamarine, VIC 3043
Australia
Tel: +61 3 9335 6449
Fax: +61 3 9330 3566
Website: www.watlow.com

Watlow Electric Manufacturing Company (Shanghai) Co. Ltd.
Room 501, Building 10, KIC Plaza
290 Songhu Road, Yangpu District
Shanghai, China 200433
China
Phone:
Local: 4006 Watlow (4006 928569)
International: +86 21 3381 0188
Fax: +86 21 6106 1423
Email: vlee@watlow.cn
Website: www.watlow.cn

ワトロー ジャパン株式会社
〒101-0047 東京都千代田区内神田1-14-4
四国ビル別館9階
Tel: 03-3518-6630 Fax: 03-3518-6632
Email: infoj@watlow.com Website: www.watlow.co.jp

Watlow Japan Ltd.
1-14-4 Uchikanda, Chiyoda-Ku
Tokyo 101-0047
Japan
Tel: +81-3-3518-6630 Fax: +81-3-3518-6632
Email: infoj@watlow.com Website: www.watlow.co.jp

Watlow Korea Co., Ltd.
#1406, E&C Dream Tower, 46, Yangpyeongdong-3ga
Yeongdeungpo-gu, Seoul 150-103
Republic of Korea
Tel: +82 (2) 2628-5770 Fax: +82 (2) 2628-5771
Website: www.watlow.co.kr

Watlow Malaysia Sdn Bhd
1F-17, IOI Business Park
No.1, Persiaran Puchong Jaya Selatan
Bandar Puchong Jaya
47100 Puchong, Selangor D.E.
Malaysia
Tel: +60 3 8076 8745 Fax: +60 3 8076 7186
Email: vlee@watlow.com
Website: www.watlow.com

瓦特龍電機股份有限公司
80143 高雄市前金區七賢二路189號 10樓之一
電話: 07-2885168 傳真: 07-2885568

Watlow Electric Taiwan Corporation
10F-1 No.189 Chi-Shen 2nd Road Kaohsiung 80143
Taiwan

Your Authorized Watlow Distributor

