

PM LEGACY™

Limit Controller

User Guide



PM3



PM6

For Configurations:
PM(3,6)(L,M) _ _ _ - A _ G _ _



WATLOW®

Powered by Possibility

1241 Bundy Boulevard., Winona, Minnesota USA 55987

Phone: +1 (507) 454-5300, Fax: +1 (507) 452-4507

<http://www.watlow.com>



ISO 9001



Registered Company
Winona, Minnesota USA

Warranty Information

The PM LEGACY™ Limit Controller is manufactured by ISO 9001-registered processes and is backed by a three-year warranty to the first purchaser for use, providing that the units have not been misapplied. Since Watlow has no control over their use, and sometimes misuse, we cannot guarantee against failure. Watlow's obligations hereunder, at Watlow's option, are limited to replacement, repair or refund of purchase price, and parts which upon examination prove to be defective within the warranty period specified. This warranty does not apply to damage resulting from transportation, alteration, misuse or abuse. The purchaser must use Watlow parts to maintain all listed ratings.

Technical Assistance

If you encounter a problem with your Watlow controller, review your configuration information to verify that your selections are consistent with your application: inputs, outputs, alarms, limits, etc. If the problem persists, you can get technical assistance from your local Watlow representative (see back cover), by e-mailing your questions to wintechsupport@watlow.com or by dialing +1 (507) 494-5656 between 7 a.m. and 5 p.m., Central Standard Time (CST). Ask for an Applications Engineer. Please have the following information available when calling:

- Complete model number
 - All configuration information
 - User's Guide
 - Factory Page
-

Return Material Authorization (RMA)

1. If you are an End User, and this PM is installed in an OEM System, please contact the OEM to get the PM repaired. If you are an OEM or Watlow Distributor, please go to www.watlow.com/rma to start the RMA process. Watlow Customer Service will then respond back with the RMA number via an email.
2. A Return Merchandise Authorization number from the Customer Service Department is required when returning any product for credit, repair or evaluation. Make sure the Return Merchandise Authorization number is on the outside of the carton and on all paperwork returned. Ship on a Freight Prepaid basis.
3. After we receive your return, we will examine it and try to verify the reason for returning it.
4. In cases of manufacturing defect, we will enter a repair order, replacement order or issue credit for material returned. In cases of customer misuse, we will provide repair costs and request a purchase order to proceed with the repair work.
5. To return products that are not defective, goods must be in new condition, in the original boxes and they must be returned within 120 days of receipt. A 20 percent restocking charge is applied for all returned stock controls and accessories.
6. If the unit cannot be repaired, you will receive a letter of explanation and be given the option to have the unit returned to you at your expense or to have us scrap the unit.
7. Watlow reserves the right to charge for no trouble found (NTF) returns.

Copyrights - Patents Pending

This PM LEGACY™ Limit User's Guide is copyrighted by Watlow Electric, Inc., © July 2020 with all rights reserved.



Table of Contents

- Table of Contents** 3
- Chapter 1: Overview** 6
 - Available PM LEGACY™ Limit Literature and Resources 6
 - Introduction 6
 - Feature Benefits 6
 - A Conceptual View of the PM 7
 - Overview 7
 - Inputs 7
 - Internal Functions 8
 - Outputs 8
 - Input Events and Output Events 10
- Chapter 2: Install & Wiring** 12
 - Installation 12
 - Dimensions 14
 - 1/32 DIN (PM3) 14
 - 1/32 DIN (PM3) Recommended Panel Spacing 14
 - 1/16 DIN (PM6) 15
 - 1/16 DIN (PM6) Recommended Panel Spacing 15
 - Wiring 16
- Chapter 3: Keys and Displays** 34
 - Responding to a Displayed Message 35
- Chapter 4: Home Page** 36
 - Changing the Set Point 38
 - Modifying the Home Page 38
 - Modifying the Display Pairs 38
 - Conventions Used in the Menu Pages 40
 - Display 40
 - Communication Protocols 41
 - Modbus Introduction to the Modbus Protocol 41
 - Profibus DP 42
- Chapter 5: Operations Page** 43
 - Analog Input Menu 44
 - Digital Input/Output Menu 45
 - Limit Menu 45
 - Alarm Menu 46
- Chapter 6: Setup Page** 48
 - Analog Input Menu 51
 - Digital Input/Output Menu 54
 - Limit Menu 56
 - Output Menu 60
 - Alarm Menu 60
 - Function Key 64
 - Global Menu 65
 - Communications Menu 66



Table of Contents (cont.)

- Chapter 7: Factory Page** 74
 - Custom 75
 - Lock Menu 76
 - Unlock Menu 78
 - Diagnostics Menu 79
 - Calibration Menu 81
- Chapter 8: Features** 83
 - Changing PM Integrated Model Number to PM Express 83
 - Saving and Restoring Settings 84
 - Programming the Home Page 85
 - Inputs 85
 - Calibration Offset 85
 - Calibration 86
 - Filter Time Constant 88
 - Sensor Selection 88
 - Scale High and Scale Low 88
 - Range High and Range Low 89
 - Outputs 89
 - Retransmitting a Process Value or Set Point 89
 - Resetting a Tripped Limit 89
 - Alarms 90
 - Process Alarms 90
 - Set Points 90
 - Hysteresis 90
 - Latching 91
 - Silencing 91
 - Blocking 91
 - Using Lockout and Password Security 91
 - Using Lockout Method 1 (Read and Set Lock) 91
 - Using Lockout Method 2 (Password Enable) 93
 - Modbus - Using Programmable Memory Blocks 95
 - CIP - Communications Capabilities 96
 - CIP Implicit Assemblies 97
 - Profibus DP - (Decentralized Peripherals) 96
 - Software Configuration 97
 - Using PM LEGACY™ Limit Configurator Software 98
- Chapter 9: Appendix** 102
 - Troubleshooting Alarms, Errors and Control Issues 102
 - Modbus - Programmable Memory Blocks 107
 - CIP Implicit Assembly Structures 110
 - PM Specifications 112
 - Ordering Information for Limit Controller Models 118
 - Declaration of Conformity 120
 - Bluetooth Enabled Product Statement 121

Safety Information











We use note, caution and warning symbols throughout this book to draw your attention to important operational and safety information.

A “**NOTE**” marks a short message to alert you to an important detail.

A “**CAUTION**” safety alert appears with information that is important for protecting your equipment and performance. Be especially careful to read and follow all cautions that apply to your application.

A “**WARNING**” safety alert appears with information that is important for protecting you, others and equipment from damage. Pay very close attention to all warnings that apply to your application.

The electrical hazard symbol,  (exclamation point in a triangle) precedes an electric shock hazard **CAUTION** or **WARNING** safety statement.

Symbol	Explanation
	CAUTION – Warning or Hazard that needs further explanation than label on unit can provide. Consult User's Guide for further information.
	ESD Sensitive product, use proper grounding and handling techniques when installing or servicing product.
	Unit protected by double/reinforced insulation for shock hazard prevention.
	Do not throw in trash, use proper recycling techniques or consult manufacturer for proper disposal.
	Enclosure made of Polycarbonate material. Use proper recycling techniques or consult manufacturer for proper disposal.
	Unit can be powered with either alternating current (ac) voltage or direct current (dc) voltage.
	Unit is a Listed device per Underwriters Laboratories®. It has been evaluated to United States and Canadian requirements for Process Control Equipment. UL 61010 and CSA C22.2 No. 61010. File E185611 QUYX, QUYX7. See: www.ul.com
	Unit is compliant with European Union directives. See Declaration of Conformity for further details on Directives and Standards used for Compliance.
	Unit has been reviewed and approved by Factory Mutual as a Temperature Limit Device per FM Class 3545 standard. See: www.fmglobal.com
	Unit has been reviewed and approved by CSA International for use as Temperature Indicating-Regulating Equipment per CSA C22.2 No. 24. See: www.csa-international.org
	Unit has been reviewed and approved by ODVA for compliance with DeviceNet communications protocol. See: www.odva.org

1

Chapter 1: Overview

Introduction

The Watlow® LEGACY™ SERIES panel mount controller is an industry leading PID controller that allows optimal performance utilizing simple control and menu functionality without complex features. It is ideally suited for basic applications and usage levels.

The LEGACY™ includes one universal input and an option for up to two outputs and is available in 1/32, and 1/16 DIN panel mount packages. It can be ordered as a PID process controller or as a dedicated over and under-temperature limit controller. A single PM controller can carry out several functions at the same time, for instance (but not limited to), PID control, checking for a limit condition, monitoring for several different alarm situations, etc... To ensure that the application requirements are being met, it is important to first give thought to each external process and then configuring the controller's internal functions to properly accommodate the application requirements.

Available PM LEGACY™ Limit Literature and Resources

Document Title and Part Number	Description
Contact Watlow Directly:	For technical assistance contact Watlow at: www.watlow.com Or call at: 1-800-WATLOW2 Or (1-800-928-5692) Or email at: wintechsupport@watlow.com
PM6 LEGACY™ Express Limit Controller Quick Start Guide Document No. 10-41692, Part No. 2126-4403	A Quick Start Guide to help you get your controller set up is available for download at https://www.watlow.com/resources-and-support/Technical-Library/ . Many other documents are available in Watlow's Technical library.
PM LEGACY™ Series Panel Mount Controller Specification Sheet	This Specifications Sheet describes the PM LEGACY™ Series hardware options, features, benefits and technical specifications. Available at: https://www.watlow.com/resources-and-support/Technical-Library/ . Many other helpful documents are available in Watlow's Technical library.

Overview

A Conceptual View of the PM

The flexibility of the PM software and hardware allows for a large range of configurations. Acquiring a better understanding of the controller's overall functionality and capabilities while at the same time planning out how the controller can be used will deliver maximum effectiveness in your application.

It is useful to think of the controller in terms of functions; there are internal and external functions. An input and an output would be considered external functions where the limit, PID or alarm function would be an internal function. Information flows from an input function to an internal function to an output function when the controller is properly configured. A single PM controller can carry out several functions at the same time, for instance (but not limited to), checking for a limit condition, monitoring for several different alarm situations, etc... To ensure that the application requirements are being met, it is important to first give thought to each external process and then configuring the controller's internal functions to properly accommodate the application requirements.

Inputs

The inputs terminal connections are located on the back side of the controller. See Figure 2. The controller, properly wired and configured will provide the information that any given programmed procedure can act upon. In a simple form, this information may come from an operator pushing a button or from a sensor monitoring the temperature of a part being heated or cooled.

Each analog input typically uses a thermocouple or RTD to read the process temperature. It can also read volts, current or resistance, allowing it to use various devices to read a wide array of values. The settings in the Analog Input Menu (Setup Page) for each analog input must be configured to match the device connected to that input.



Figure 1: PM6 Controller Shown Here

A PM with digital input/output (DIO) hardware includes two sets of terminals where each of which can be used as either an input or an output. Each pair of terminals must be configured to function as either an input or output with the direction parameter in the Digital Input/Output Menu (Setup Page). Each digital input reads whether a device is active or inactive.

The Reset Key on the front panel of the PM also operates as a digital input by toggling the function assigned to it in the Digital Input Function parameter in the Reset Key Menu (Set-up Page).

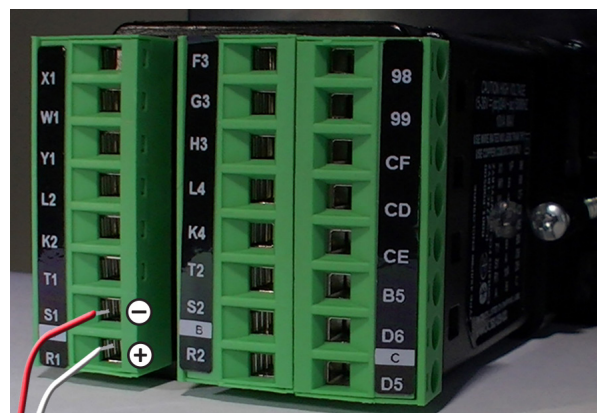

Figure 2: Input Terminal Connections Shown Here

(Overview Continued)

Internal Functions

The controller will use input signals to calculate a value and then perform an operation. A sample of some functions may be as simple as:

- Detect a failure of the primary sensing device and trip a contactor to remove power from the heating element.
- Reading a digital input to set a state to true or false.
- Evaluate an incoming temperature to determine an alarm state (on or off).
- Compare an input value to the set point and calculate the optimal power for a heater.

To set up a function, it's important to define the source, or instance, to use. For example, if the control is equipped with DIO they can be configured to respond to an alarm. If configured as such, the digital output must be tied to the desired alarm instance (1 to 4). Using this as an example, the Function for the digital output would be defined as an Alarm where the Instance would be selected as 1, 2, 3, or 4 corresponding to the alarm instance that will drive the output. Keep in mind that a function is a user-programmed internal process that does not execute any action outside of the controller. To have any effect outside of the controller, an output must be configured to respon

Outputs

The Output Wire Terminals are located on the back side of the controller. See Figure 3. The Outputs properly wired and configured can perform various functions or actions in response to information provided by a function such as, removal of the control voltage to a contactor; operating a heater, turning a light on or off, unlocking a door, etc.

Assign a Function to any available output on the Setup Page within the Output Menu or Digital Input/Output Menu. Then select which instance of that function will drive the selected output. For example, you might assign an output to respond to alarm 4 (instance 4).

You can assign more than one output to respond to a single instance of a function. For example, alarm 2 could be used to trigger a light connected to output 1 and a siren connected to digital output 5.



Figure 3: Output Wiring Example

Features and Benefits

Simplified Menu

- Fits basic applications with a user-friendly interface supported by two menus and a streamlined list of parameters.
- Eliminates user complexity often experienced with more advanced controllers and unnecessary features.
- Reduces user training costs and user programming errors

PID Auto-Tune

- Provides auto-tune for fast, efficient start-up

Standard Bus Communications

- Allows easy product configuration via PC communications protocol and free software.
- Saves time, simplifies programming process and improves reliability of controller setup

Factory Mutual (FM) Approved Over and Under Limit with Auxiliary Outputs.

- Increases user and equipment safety for over and under-temperature conditions.

Function Key

- Enables simple, one-touch operation of user-defined, repetitive activities

Touch-Safe Package

- Increases installer and operator safety
- Complies with IP2X requirements

EZ-LINK™ Mobile Application for iPhone® and Android™

- Expedites controller setup with intuitive navigation
- Simplifies setting parameters with plain text names and descriptions
- Connects quickly and easily via Bluetooth® wireless communications

SMOOTH TOUCH™ Keypad

- Eliminates contamination points on the front of the controller.
- Prevents premature failure of mechanical components
- Creates a better seal on front panel.
- Ensures an easy to clean surface.

Agency approvals: UL® listed, CSA, CE, RoHS, W.E.E.E., FM, SEMI F47-0200, Class 1, Div. 2 rating on selected models

- Assures prompt product acceptance
- Reduces end product documentation costs

P3T Armor Sealing System

- Compiles to NEMA 4X, IP66 and IP67 specifications
- Allows controller to be cleaned and washed
- Certified UL® 50 Type X4X indoor applications.

Consistent Termination Labeling (CTL) Connection System

- Simplifies switching between products
- Speeds up user's system documentation

Three-Year Warranty

- Demonstrates Watlow's reliability and product support

High-Amperage Power Control Output (1/16 DIN only)

- Drives 15 ampere resistive loads direct
- Reduces component count
- Saves panel space and simplifies wiring
- Reduces cost of ownership

Input Events and Output Events

Input events are internal state input event 2. The setting of Digital Input Function (Setup Page, Digital Input/Output Menu) does not change the relationship between the input and the event. An input will still control the input event state, even if Digital Input Function is set to None.

PM LEGACY™ Limit PM Models - System Diagram (with communications options 2, 3, 5 or 6)

Universal Sensor Input, Configuration Communications, Red/Green 7-Segment Display

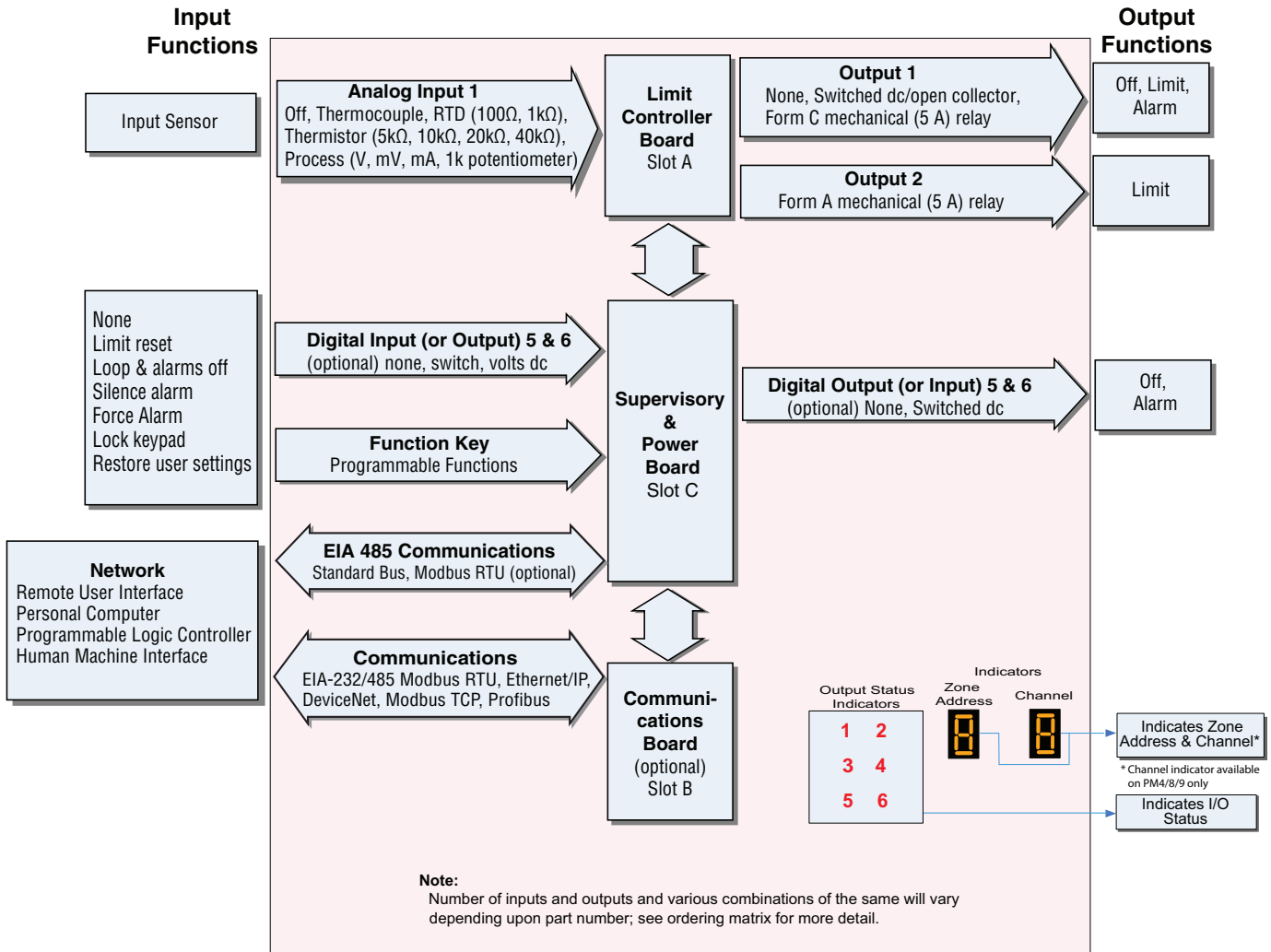

PM LEGACY™ Limit PM Models - Input/Output (no communications options 2, 3, 5 or 6)

Universal Sensor Input, Configuration Communications, Red/Green 7-Segment Display

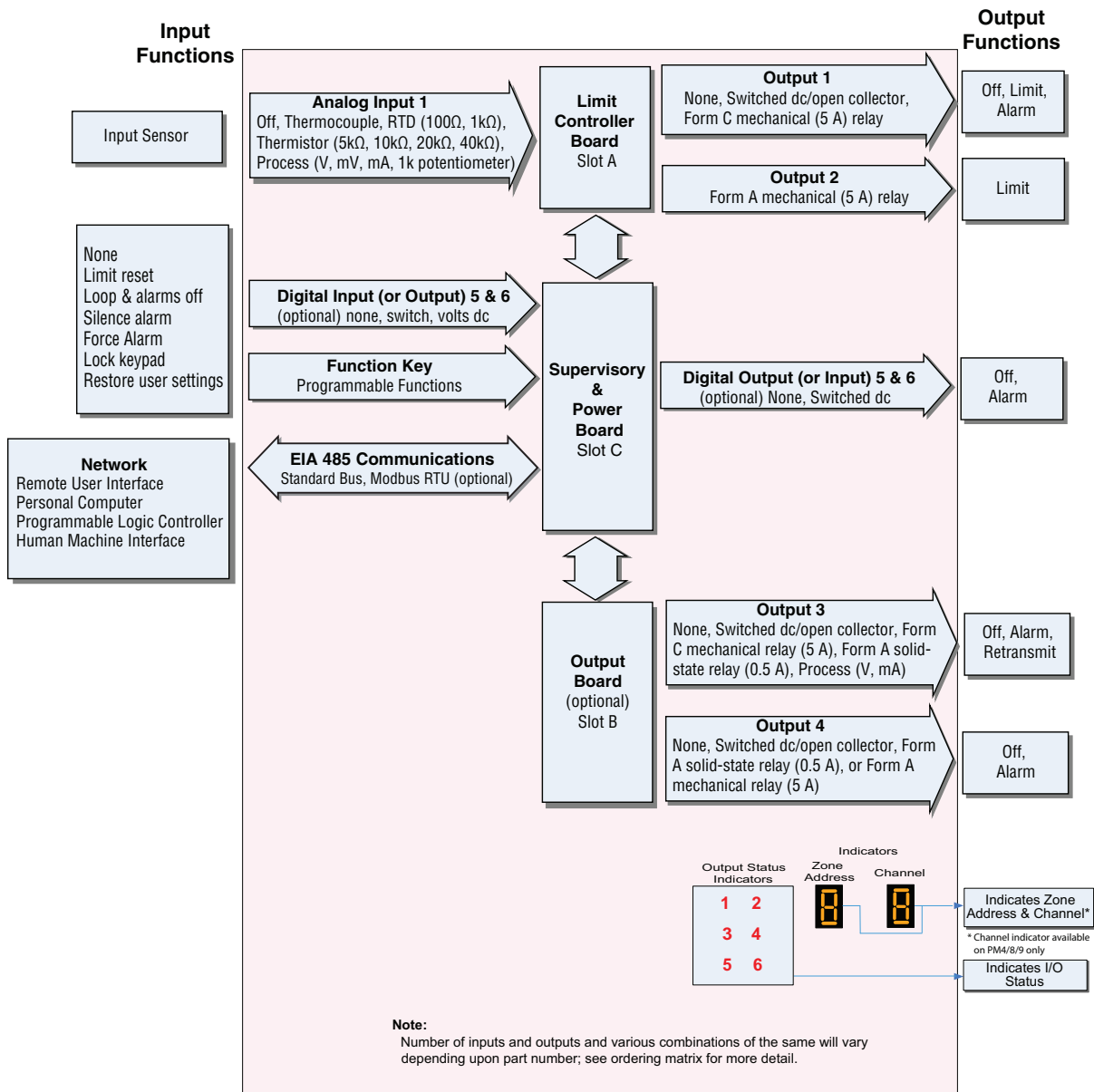

PM LEGACY™ Limit All Models System Diagram

(No communications options 2, 3, 5 or 6)

Universal Sensor Input, Configuration Communications, Red/Green 7-Segment Display

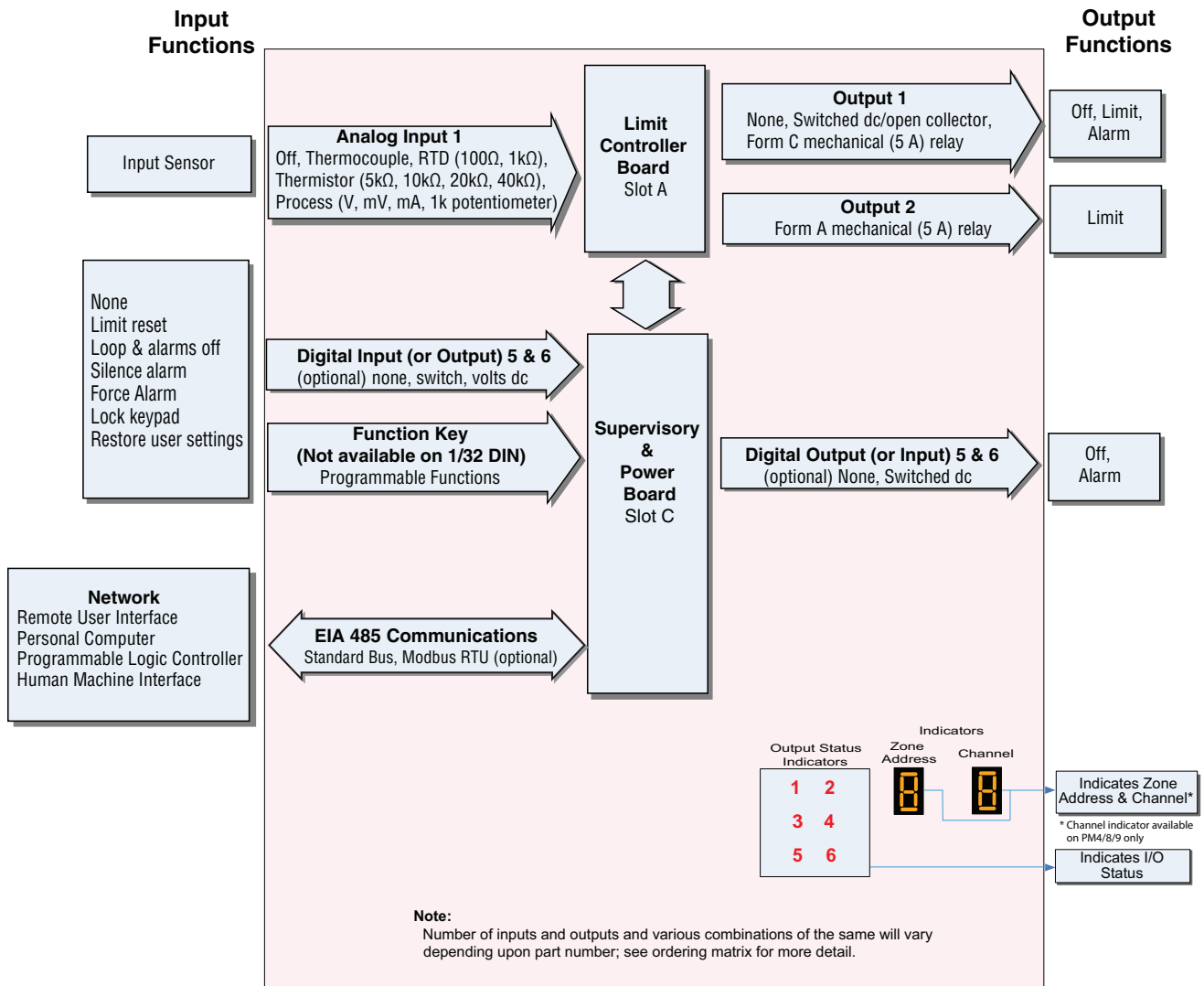

2

Chapter 2: Install & Wiring

INSTALLTION

1. For a PM3 Controller, make the panel cutout using the measurements shown on page 6.
2. For a PM6 Controller, make the panel cutout using the measurements shown on page 7.
3. Remove the green terminal connectors and the mounting collar assembly.
4. Insert the controller into the panel cutout from the front. See Figure 2. The controller shown is a PM6 Controller.
5. Orient the collar base so the flat side faces front and the screw openings are on the sides (see Figure 2), then slide the base over the back of the controller.
6. Slide the mounting bracket over the controller with the screws aligned to the collar base. See Figure 2. Push the bracket gently but firmly until the hooks snap into the slots in the case.
7. Tighten the two #6-19 x 1.5 in. screws with a phillips screwdriver until the device is flush to the panel (3 to 4 in-lbs torque). See Figure 3.
8. Reinstall the terminal connectors to their original locations.

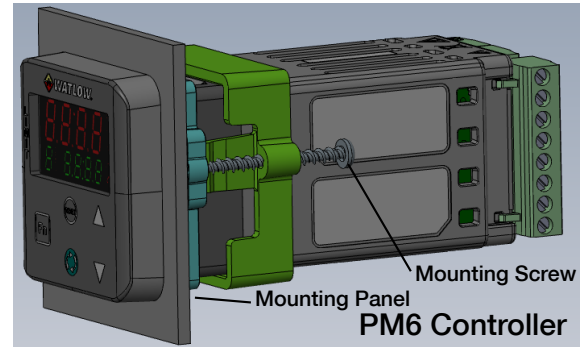

Figure 1: PM6 Installation

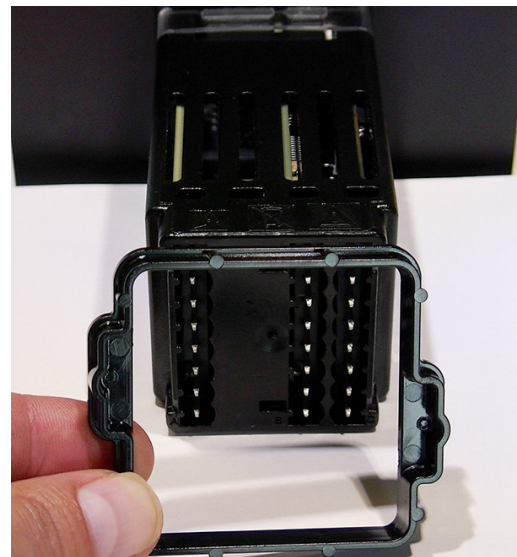

Figure 2: Slide Mounting Bracket over Controller



Figure 3: Tighten the Mounting Screws

Dimensions

1/32 DIN (PM3)

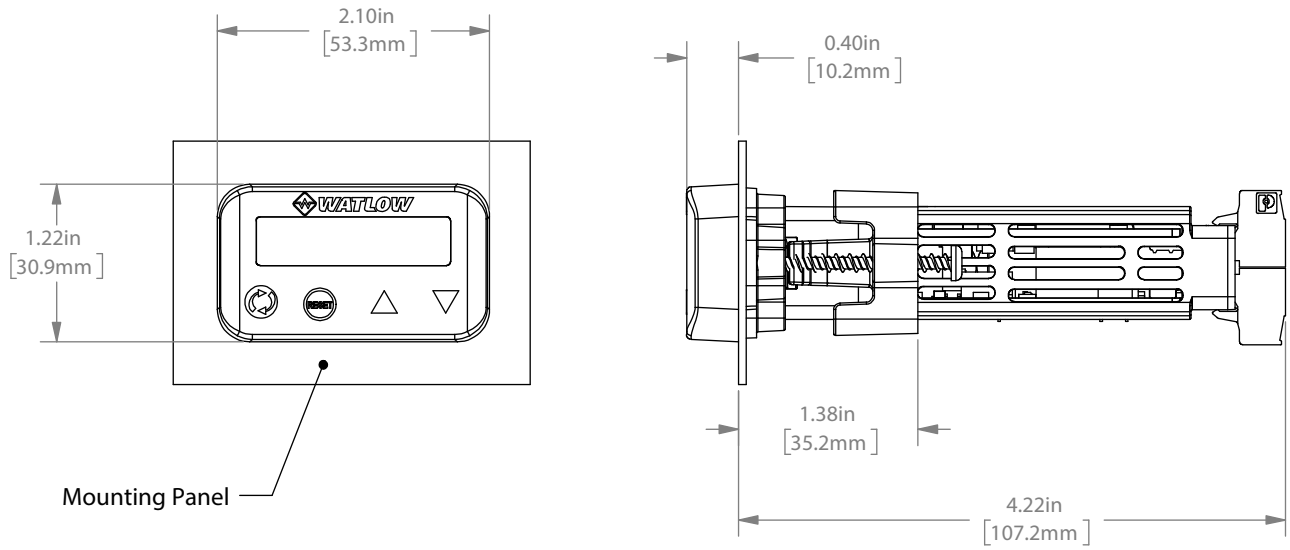

1/32 DIN (PM3) Recommended Panel Spacing

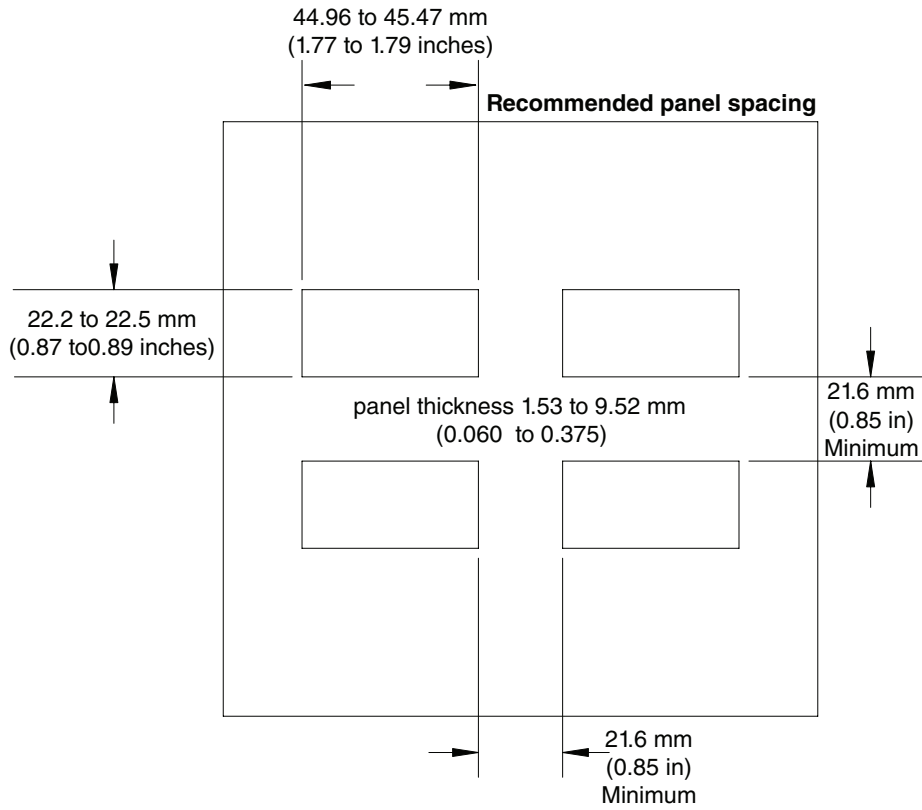

1/16 DIN (PM6)

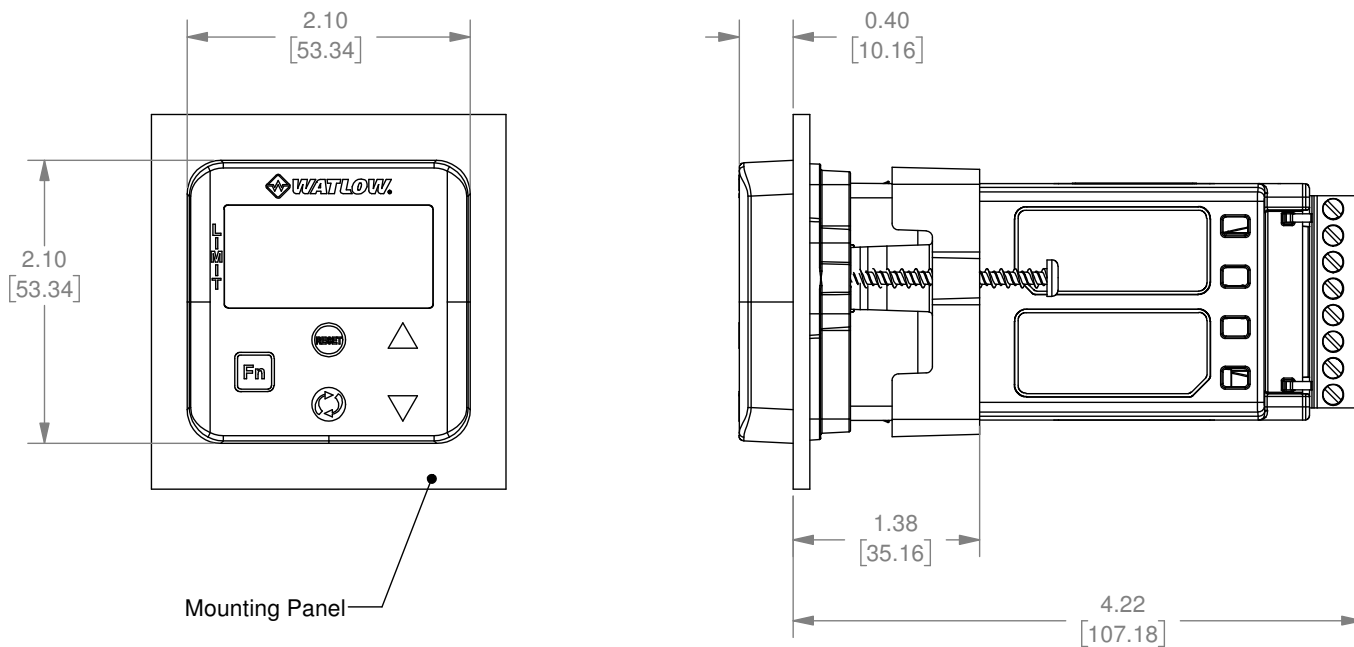

1/16 DIN (PM6) Recommended Panel Spacing

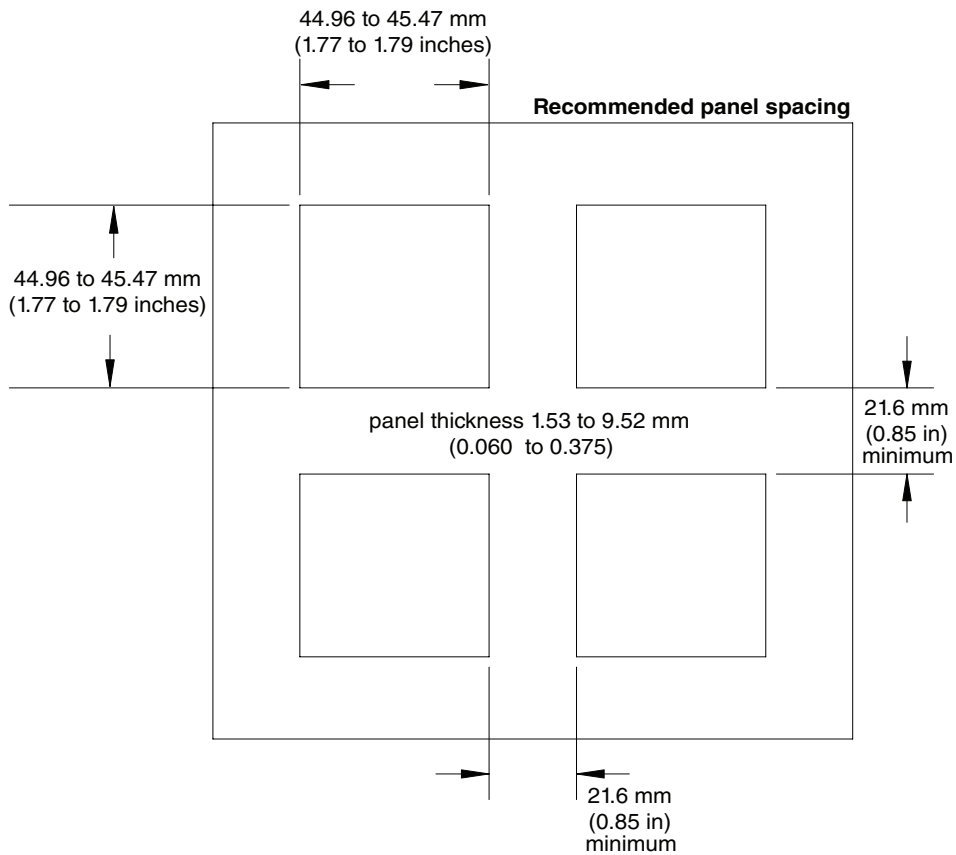

Wiring

Slot A	Slot B		Terminal Function	Configuration	
Inputs			Universal, RTD and Thermistor Inputs		
T1 S1 R1			S2 (RTD) or current + S3 (RTD), thermocouple -, current -, volts - or potentiometer wiper, thermistor S1 (RTD), thermocouple + or volts +, thermistor, potentiometer	Universal Sensor Input 1: all configurations	
Outputs			Switched dc/open collector		
1	2	3	4		
X1 W1 Y1		X3 W3 Y3		Common (Any switched dc output can use this common.) dc- (open collector) dc+	Output 1: PM6[L,M] _[C] J-AA _G_ _ Output 3: PM6[L,M] _ _J-AA[C] _ G_ _
			Switched dc		
			W4 Y4	dc- dc+	Output 4: PM6[L,M] _ _J-AA_ [C] G_ _
			Universal Process		
		F3 G3 H3		voltage or current - voltage + current +	Output 3: PM6[L,M] _ _J-AA[F]_G_ _
			Mechanical Relay 5 A, Form C		
L1 K1 J1		L3 K3 J3		normally open common normally closed	Output 1: PM6[L,M] _ [E] J-AA_ _G_ _ Output 3: PM6[L,M] _ _J-AA[E] _G_ _
			Mechanical Relay 5 A, Form A		
	L2 K2		L4 K4	normally open common	Output 2: PM6[L,M] _ _[J] -AA_ _G_ _ Output 4: PM6[L,M] _ _J-AA_[J] G_ _
			Solid-State Relay 0.5 A, Form A		
		L3 K3	L4 K4	normally open common	Output 3: PM6[L,M] _ _J-AA[K] _G_ _ Output 4: PM6[L,M] _ _J-AA _ [K] G_ _
Communications			Modbus RTU 232/485 Communications		
	CB CA CC CB CA C5 C3 C2	CB CA CC CB CA C5 C3 C2	Modbus RTU EIA-485 T+/R+ Modbus RTU EIA-485 T-/R- Modbus RTU EIA-485 common Modbus RTU EIA-485 T+/R+ Modbus RTU EIA-485 T-/R- Modbus RTU EIA-232 common Modbus RTU EIA-232 to DB9 pin 2 Modbus RTU EIA-232 to DB9 pin 3	Slot B: PM6[L,M] _ _ J-[F,2] AAAG_ _	
			DeviceNet™ Communications		

Wiring (cont.)

	V+ CH SH CL V-	V+ CH SH CL V-	DeviceNet™ power Positive side of DeviceNet™ bus Shield interconnect Negative side of DeviceNet™ bus DeviceNet™ power return	DeviceNet™ Communications Slot B: PM6[L,M] _ _ J-[H,5] AAAG_ _
Slot A	Slot B		Terminal Function	Configuration
Communications (cont.)		EtherNet/IP™ and Modbus® TCP		
	E8 E7 E6 E5 E4 E3 E2 E1	E8 E7 E6 E5 E4 E3 E2 E1	EtherNet/IP™ and Modbus TCP unused EtherNet/IP™ and Modbus TCP unused EtherNet/IP™ and Modbus TCP receive - EtherNet/IP™ and Modbus TCP unused EtherNet/IP™ and Modbus TCP unused EtherNet/IP™ and Modbus TCP receive + EtherNet/IP™ and Modbus TCP transmit - EtherNet/IP™ and Modbus TCP transmit +	Slot B: PM6[L,M] _ _ J-[G,3] AAAG_ _
		Profibus DP Communications		
	VP B A DG trB B A trA	VP B A DG trB B A trA	Voltage Potential EIA-485 T+/R+ EIA-485 T-/R- Digital ground (common) Termination resistor B EIA-485 T+/R+ EIA-485 T-/R- Termination resistor A	Slot B: PM6[L,M] _ _ J-[J,6] AAAG_ _

Terminal Definitions for Slot C

Slot C	Terminal Function	Configuration
Power		
98 99	Power input: ac or dc+ Power input: ac or dc-	all
Standard Bus or Modbus EIA-485		
CC CA CB	Standard Bus or Modbus RTU EIA-485 Common Standard Bus or Modbus RTU EIA-485 T-/R- Standard Bus or Modbus RTU EIA-485 T+/R+	Standard Bus or Modbus PM6[L,M] _ _ J-[E,1] A_ _ G_ _
Standard Bus EIA-232/485		
CF CD CE	Standard Bus EIA-485 common Standard Bus EIA-485 T-/R- Standard Bus EIA-485 T+/R+	PM _ _ _ _-[A, 2 or 3] _ _ _ AAA
2 - Digital I/O Points		
B5 D6 D5	Digital input-output common Digital input or output 6 Digital input or output 5	PM6[L,M] [2,4] _ J-[F,2] A_ _ G_ _

Slot Orientation - Back View

1/32 DIN Horizontal PM3

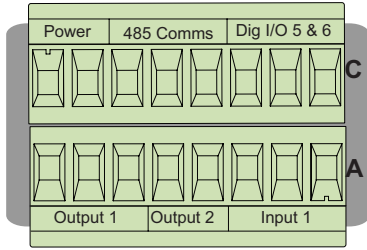

1/16 DIN Vertical PM6

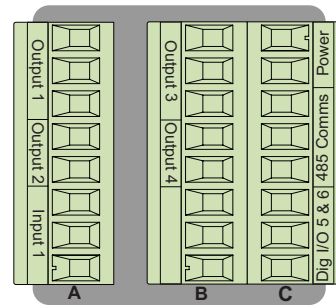

Note: Slot B above can also be configured with a communications card.

PM Isolation Block

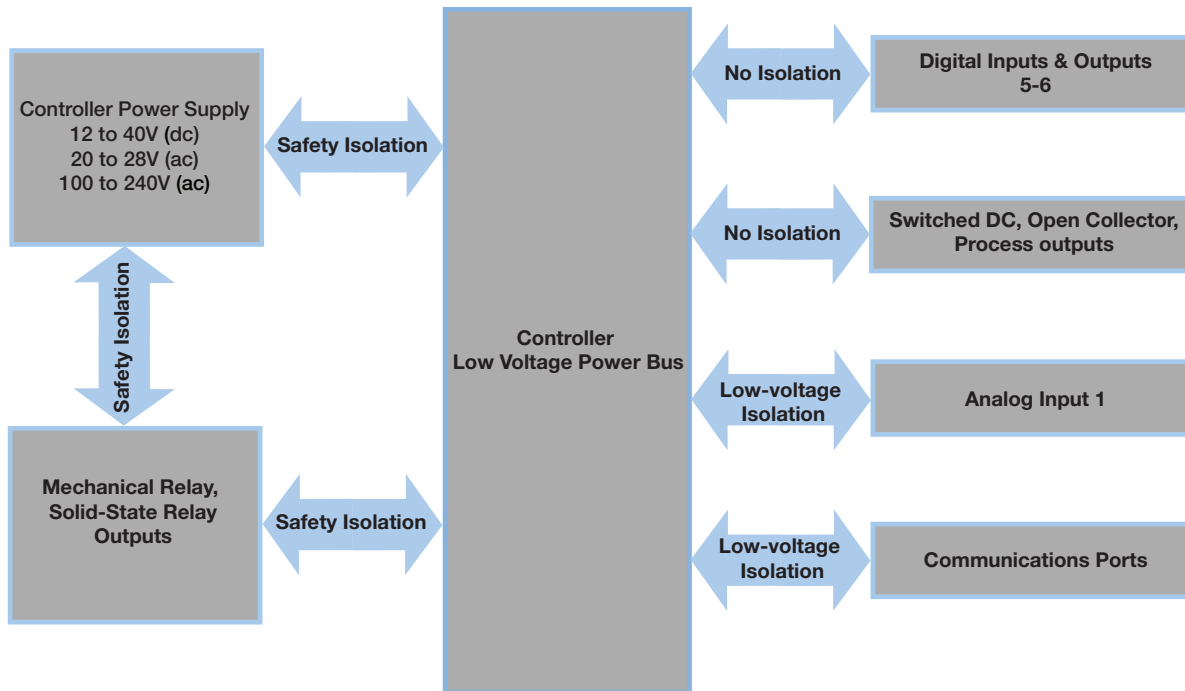

Low-voltage Isolation: 42V peak
Safety Isolation: 2300V (ac)

Warning: ⚠

Use National Electric (NEC) or other country-specific standard wiring and safety practices when wiring and connecting this controller to a power source and to electrical sensors or peripheral devices. Failure to do so may result in damage to equipment and property, and/or injury or loss of life.

Note:

Maximum wire size termination and torque rating:

- 0.0507 to 3.30 mm² (30 to 12 AWG) single-wire termination or two 1.31 mm² (16 AWG)
- 0.56 Nm (5.0 in-lb.) torque

Note:

Adjacent terminals may be labeled differently, depending on the model number.

Note:

To prevent damage to the controller, do not connect wires to unused terminals.

Note:

Maintain electrical isolation between analog input 1, digital input-outputs, switched dc/open collector outputs and process outputs to prevent ground loops.

Low Power

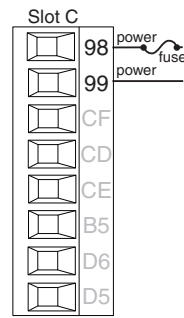

PM6[L,M] [3,4] _ J- _ A _ G _ _

- Minimum/Maximum Ratings
- 12 to 40V = (dc)
- 20 to 28V ~ (ac) Semi Sig F47
- 47 to 63 Hz
- 10VA maximum power consumption (PM6)

High Power

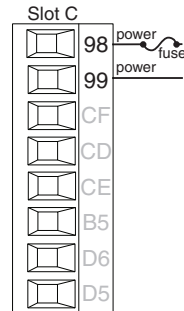

PM6[L,M] [1,2] _ J- _ A _ G _ _

- Minimum/Maximum Ratings
- 85 to 264V ~ ac
- 100 to 240V ~ (ac) Semi Sig F47
- 47 to 63 Hz
- 10VA maximum power consumption (PM6)

Digital Input 5 - 6

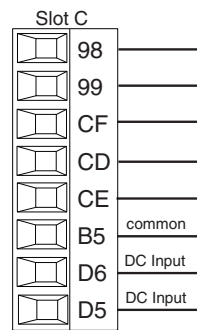

PM6[L,M] [2,4] _ J- _ A _ G _ _

Digital Input

- Update rate 10 Hz
- Dry contact or dc voltage
- DC Voltage
 - Input not to exceed 36V = (dc) at 3mA
 - Input active when > 3V = (dc) @ 0.25mA
 - Input inactive when < 2V

Voltage Input

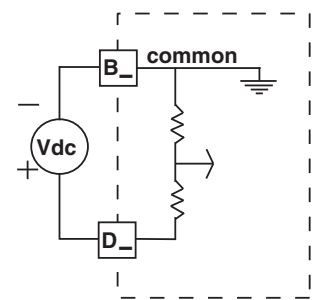

Dry Contact

- Input inactive when > 500Ω
- Input active when < 100Ω
- Maximum short circuit 13mA

Dry Contact

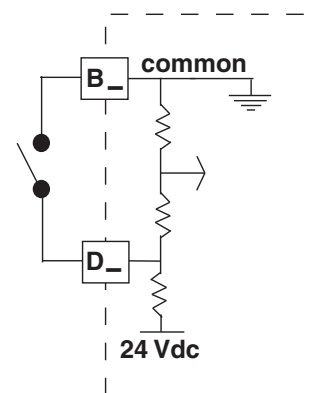

Warning: 

Use National Electric (NEC) or other country-specific standard wiring and safety practices when wiring and connecting this controller to a power source and to electrical sensors or peripheral devices. Failure to do so may result in damage to equipment and property, and/or injury or loss of life.

Note:

Maximum wire size termination and torque rating:

- 0.0507 to 3.30 mm² (30 to 12 AWG) single-wire termination or two 1.31 mm² (16 AWG)
- 0.56 Nm (5.0 in-lb.) torque

Note:

Adjacent terminals may be labeled differently, depending on the model number.

Note:

To prevent damage to the controller, do not connect wires to unused terminals.

Note:

Maintain electrical isolation between analog input 1, digital input-outputs, switched dc/open collector outputs and process outputs to prevent ground loops.

Input 1 Thermocouple

PM6[L] _ _ J- _ _ _ G _ _

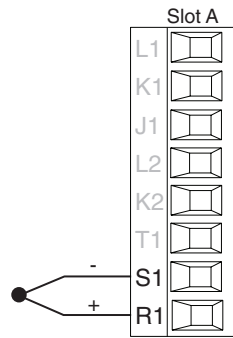

- 2k Ω maximum source resistance
- >20M Ω input impedance
- 3 μ A open-sensor detection
- Thermocouples are polarity sensitive. The negative lead (usually red) must be connected to S1
- To reduce errors, the extension wire for thermocouples must be of the same alloy as the thermocouple

Input 1 RTD

PM6[L] _ _ J- _ _ _ G _ _

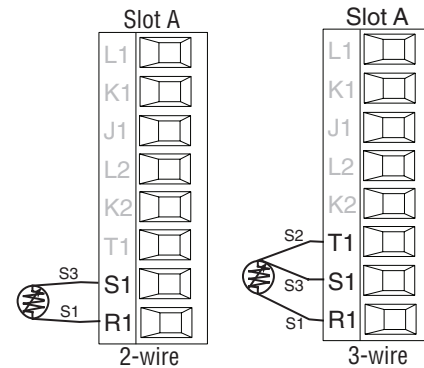

- Platinum, 100 and 1k Ω @ 0 $^{\circ}$ C
- Calibration to DIN curve (0.00385 $\Omega/\Omega/^{\circ}$ C)
- 20 Ω total lead resistance
- RTD excitation current of 0.09mA typical. Each ohm of lead resistance may affect the reading by 0.03 $^{\circ}$ C.
- For 3-wire RTDs, the S1 lead (usually white) must be connected to R1 and/or R2
- For best accuracy use a 3-wire RTD to compensate for lead-length resistance. All three lead wires must have the same resistance

Input 1 Process

PM6[L] _ _ J- _ _ _ G _ _

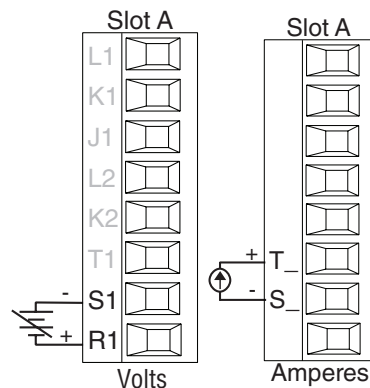

- 0 to 20mA @ 100 Ω input impedance
- 0 to 10V $\overline{=}$ (dc) @ 20k Ω input impedance
- 0 to 50mV $\overline{=}$ (dc) @ 20k Ω input impedance
- Scalable

Warning: ⚠

Use National Electric (NEC) or other country-specific standard wiring and safety practices when wiring and connecting this controller to a power source and to electrical sensors or peripheral devices. Failure to do so may result in damage to equipment and property, and/or injury or loss of life.

Note:

Maximum wire size termination and torque rating:

- 0.0507 to 3.30 mm² (30 to 12 AWG) single-wire termination or two 1.31 mm² (16 AWG)
- 0.56 Nm (5.0 in-lb.) torque

Note:

Adjacent terminals may be labeled differently, depending on the model number.

Note:

To prevent damage to the controller, do not connect wires to unused terminals.

Note:

Maintain electrical isolation between analog input 1, digital input-outputs, switched dc/open collector outputs and process outputs to prevent ground loops.

Quencharc Note:

Switching pilot duty inductive loads (relay coils, solenoids, etc.) with the mechanical relay, solid state relay or open collector output options requires use of an R.C. suppressor.

Input 1 Potentiometer

PM6[L] _ _ J- _ _ G _ _

- Use a 1kΩ potentiometer.

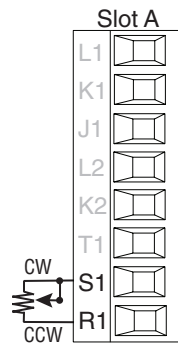

Input 1 Thermistor

PM6[M] _ _ J- _ _ G _ _

- >20MΩ input impedance
- 3μA open-sensor detection

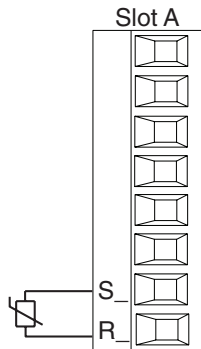

Digital Output 5 - 6

PM6[L,M] [2,4] _ J- A _ G _ _

Digital Output

- SSR drive signal
- Update rate 10 Hz
- Maximum open circuit voltage is 22 to 25V \approx (dc)
- PNP transistor source
- Typical drive; 21mA @ 4.5V \approx (dc) for DO5, and 11mA @ 4.5V for DO6
- Current limit 24mA for Output 5 and 12mA Output 6
- Output 5 capable of driving one 3-pole DIN-A-MITE
- Output 6 capable of driving one 1-pole DIN-A-MITE

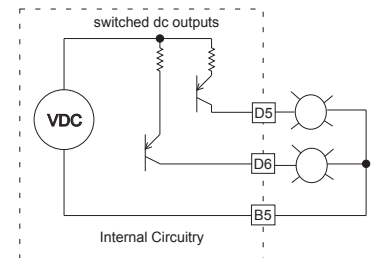

Note:
See output curves below.

Warning: ⚠

Use National Electric (NEC) or other country-specific standard wiring and safety practices when wiring and connecting this controller to a power source and to electrical sensors or peripheral devices. Failure to do so may result in damage to equipment and property, and/or injury or loss of life.

Note:

Maximum wire size termination and torque rating:

- 0.0507 to 3.30 mm² (30 to 12 AWG) single-wire termination or two 1.31 mm² (16 AWG)
- 0.56 Nm (5.0 in-lb.) torque

Note:

Adjacent terminals may be labeled differently, depending on the model number.

Note:

To prevent damage to the controller, do not connect wires to unused terminals.

Note:

Maintain electrical isolation between analog input 1, digital input-outputs, switched dc/open collector outputs and process outputs to prevent ground loops.

Quencharc Note:

Switching pilot duty inductive loads (relay coils, solenoids, etc.) with the mechanical relay, solid state relay or open collector output options requires use of an R.C. suppressor.

Output 1, 3 Mechanical Relay, Form C

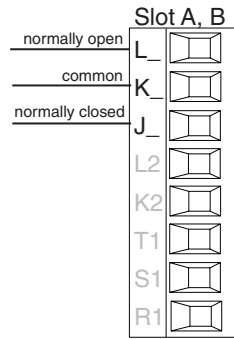

- 5A at 240V ~ (ac) or 30V = (dc) maximum resistive load
- 20mA at 24V minimum load
- 125VA pilot duty at 120/240V ~ (ac), 25VA at 24V ~ (ac)
- 100,000 cycles at rated load
- Output does not supply power.
- For use with ac or dc

See Quencharc note

Output 1 PM[3,6][L,M] _ [E]

J - _ A _ G _ _

Output 3 PM6[L,M] _ _ J - _

A [E] _ G _ _

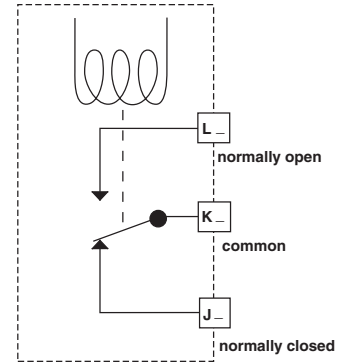

Warning: ⚠

Use National Electric (NEC) or other country-specific standard wiring and safety practices when wiring and connecting this controller to a power source and to electrical sensors or peripheral devices. Failure to do so may result in damage to equipment and property, and/or injury or loss of life.

Note:

- Maximum wire size termination and torque rating:
- 0.0507 to 3.30 mm² (30 to 12 AWG) single-wire termination or two 1.31 mm² (16 AWG)
 - 0.56 Nm (5.0 in-lb.) torque

Note:

Adjacent terminals may be labeled differently, depending on the model number.

Note:

To prevent damage to the controller, do not connect wires to unused terminals.

Note:

Maintain electrical isolation between analog input 1, digital input-outputs, switched dc/open collector outputs and process outputs to prevent ground loops.

Quencharc Note:

Switching pilot duty inductive loads (relay coils, solenoids, etc.) with the mechanical relay, solid state relay or open collector output options requires use of an R.C. suppressor.

Output 2, 4 Mechanical Relay, Form A

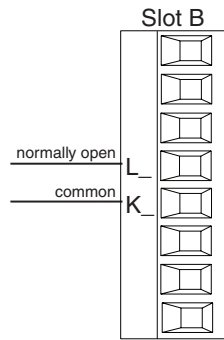

- 5A at 240V \hat{A} (ac) or 30V \hat{I} (dc) maximum resistive load
- 20mA at 24V minimum load
- 125VA pilot duty @ 120/240V \sim (ac), 25VA at 24V \sim (ac)
- 100,000 cycles at rated load
- Output does not supply power
- For use with ac or dc

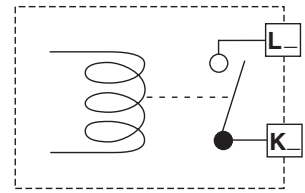

See Quencharc note

Outputs 2 and 4:

Output 2 PM[3,6] {L,M} _ _ [J] - _ A _ _ G _ _

Output 4 PM[6] {L,M} _ _ J - _ A _ [J] G _ _

Output 3, 4 Solid-State Relay, Form A

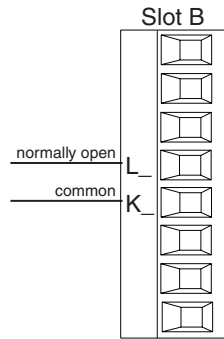

- 0.5A at 20 to 264V \sim (ac) maximum resistive load
- 20VA 120/240V \sim (ac) pilot duty
- Opto-isolated, without contact suppression
- Maximum off state leakage of 105 μ A
- Minimum holding current of 10mA
- Output does not supply power
- Do not use on dc loads.

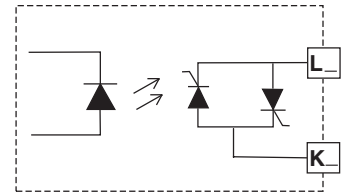

See Quencharc note

Output 3 PM6[L,M] _ _ J - _ A [K] _ G _ _

Warning: ⚠

Use National Electric (NEC) or other country-specific standard wiring and safety practices when wiring and connecting this controller to a power source and to electrical sensors or peripheral devices. Failure to do so may result in damage to equipment and property, and/or injury or loss of life.

Note:

Maximum wire size termination and torque rating:

- 0.0507 to 3.30 mm² (30 to 12 AWG) single-wire termination or two 1.31 mm² (16 AWG)
- 0.56 Nm (5.0 in-lb.) torque

Note:

Adjacent terminals may be labeled differently, depending on the model number.

Note:

To prevent damage to the controller, do not connect wires to unused terminals.

Note:

Maintain electrical isolation between analog input 1, digital input-outputs, switched dc/open collector outputs and process outputs to prevent ground loops.

Quencharc Note:

Switching pilot duty inductive loads (relay coils, solenoids, etc.) with the mechanical relay, solid state relay or open collector output options requires use of an R.C. suppressor.

Output 3 Universal Process

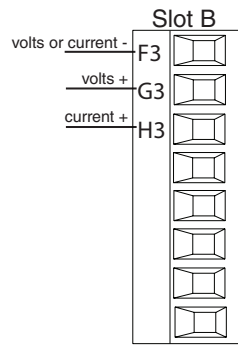

- 0 to 20mA into 800 Ω maximum load
- 0 to 10V (dc) into 1 kΩ minimum load
- Scalable
- Output supplies power
- Cannot use voltage and current outputs at same time
- Output may be used as retransmit or control.

Output 3:

PM6[L,M] _ _ J - _ A [F] _
G _ _

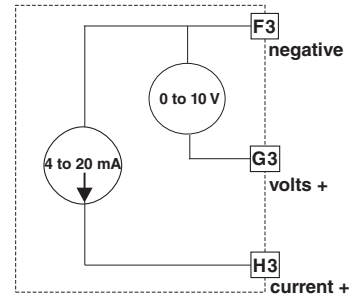

Warning: ⚠

Use National Electric (NEC) or other country-specific standard wiring and safety practices when wiring and connecting this controller to a power source and to electrical sensors or peripheral devices. Failure to do so may result in damage to equipment and property, and/or injury or loss of life.

Note:

- Maximum wire size termination and torque rating:
- 0.0507 to 3.30 mm² (30 to 12 AWG) single-wire termination or two 1.31 mm² (16 AWG)
 - 0.56 Nm (5.0 in-lb.) torque

Note:

Adjacent terminals may be labeled differently, depending on the model number.

Note:

To prevent damage to the controller, do not connect wires to unused terminals.

Note:

Maintain electrical isolation between analog input 1, digital input-outputs, switched dc/open collector outputs and process outputs to prevent ground loops.

Quencharc Note:

Switching pilot duty inductive loads (relay coils, solenoids, etc.) with the mechanical relay, solid state relay or open collector output options requires use of an R.C. suppressor.

Output 4 Switched DC

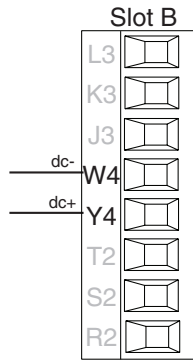

- Maximum open circuit voltage is 22 to 25V \approx (dc)
- 30mA max. per single output / 40mA max. total per paired outputs (1 & 2, 3 & 4)
- Typical drive; 4.5V \approx (dc) @ 30mA
- Short circuit limited to <50mA
- NPN transistor sink
- Use dc- and dc+ to drive external solid-state relay
- 1-pole DIN-A-MITE: up to 4 in parallel or 4 in series
- 2-pole DIN-A-MITE: up to 2 in parallel or 2 in series
- 3-pole DIN-A-MITE: up to 2 in series

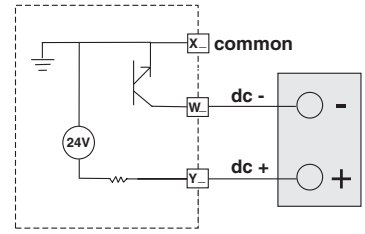

Output 4:
 PM6[L,M] _ _ J - _ A _ [C]
 G _ _

Warning: ⚠

Use National Electric (NEC) or other country-specific standard wiring and safety practices when wiring and connecting this controller to a power source and to electrical sensors or peripheral devices. Failure to do so may result in damage to equipment and property, and/or injury or loss of life.

Note:

Maximum wire size termination and torque rating:

- 0.0507 to 3.30 mm² (30 to 12 AWG) single-wire termination or two 1.31 mm² (16 AWG)
- 0.56 Nm (5.0 in-lb.) torque

Note:

Adjacent terminals may be labeled differently, depending on the model number.

Note:

To prevent damage to the controller, do not connect wires to unused terminals.

Note:

Maintain electrical isolation between analog input 1, digital input-outputs, switched dc/open collector outputs and process outputs to prevent ground loops.

Quencharc Note:

Switching pilot duty inductive loads (relay coils, solenoids, etc.) with the mechanical relay, solid state relay or open collector output options requires use of an R.C. suppressor.

Output 1, 3 Switched DC/Open Collector

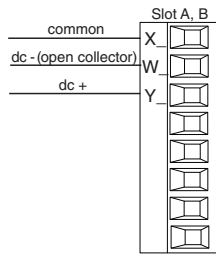

Switched DC

- Maximum open circuit voltage is 22 to 25V \approx (dc)
- 30mA max. per single output
- Typical drive; 4.5V \approx (dc) @ 30mA
- Short circuit limited to <50mA
- NPN transistor sink
- Use dc- and dc+ to drive external solid-state relay
- 1-pole DIN-A-MITE: up to 4 in parallel or 4 in series
- 2-pole DIN-A-MITE: up to 2 in parallel or 2 in series
- 3-pole DIN-A-MITE: up to 2 in series

Open Collector

- 100mA maximum output current sink
- 30V \approx (dc) max. supply voltage
- Any switched dc output can use the common terminal.
- Use an external power supply to control a dc load, with the load positive to the positive of the power supply, the load negative to the open collector and common to the power supply negative.

See Quencharc note.

Switched DC

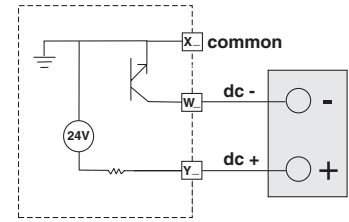

Open Collector

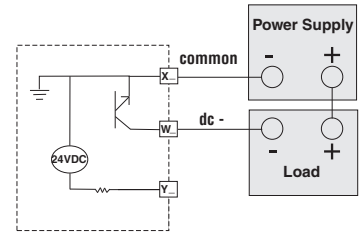

Output 1: (X1,-W1,+Y1)

PM[3,6] _ _ _ [C] J - _ A _
_ G _ _

Output 3: (X3,-W3,+Y3)

PM6 _ _ _ J - _ A [C] _ G _

Quencharc Wiring Example

In this example the Quencharc circuit (Watlow part# 0804-0147-0000) is used to protect PM internal circuitry from the counter electromagnetic force from the inductive user load when de-energized. It is recommended that this or an equivalent Quencharc be used when connecting inductive loads to PM outputs.

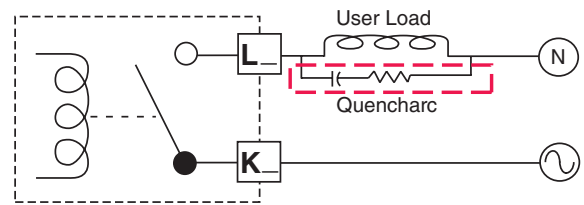

Standard Bus EIA-485 Communications

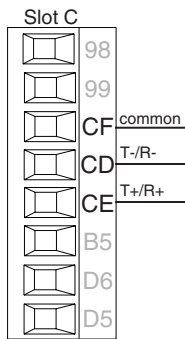

- Wire T-/R- to the A terminal of the EIA-485 port.
- Wire T+/R+ to the B terminal of the EIA-485 port.
- Wire common to the common terminal of the EIA-485 port.
- Do not route network wires with power wires. Connect network wires in daisy-chain fashion when connecting multiple devices in a network.
- Do not connect more than 16 PM LEGACY™ Limit controllers on a network.
- Maximum network length: 1,200 meters (4,000 feet)
- 1/8th unit load on EIA-485 bus

PM[3,6][L,M] _ _ J - [A,B] _ _ _ G _ _

* All models include Standard Bus communications (instance 1)

Note:

Do not leave a USB to EIA-485 converter connected to Standard Bus without power (i.e., disconnecting the USB end from the computer while leaving the converter connected on Standard Bus). Disturbance on the Standard Bus may occur.

Modbus RTU or Standard Bus EIA-485 Communications

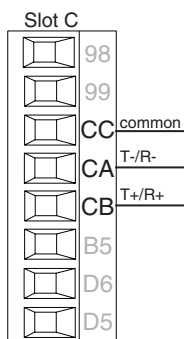

- Wire T-/R- to the A terminal of the EIA-485 port.
- Wire T+/R+ to the B terminal of the EIA-485 port.
- Wire common to the common terminal of the EIA-485 port.
- Do not route network wires with power wires. Connect network wires in daisy-chain fashion when connecting multiple devices in a network.
- A termination resistor may be required. Place a 120 Ω resistor across T+/R+ and T-/R- of last controller on network.
- Only one protocol per port is available at a time: either Modbus RTU or Standard Bus.
- Do not connect more than 16 PM LEGACY™ Limit controllers on a Standard Bus network.
- Maximum number of PM LEGACY™ Limit controllers on a Modbus network is 247.
- Maximum network length: 1,200 meters (4,000 feet)
- 1/8th unit load on EIA-485 bus.
- Communications instance 1

PM[3,6][L,M] _ _ J - [E,1] _ _ _ G _ _

Note:

Do not leave a USB to EIA-485 converter connected to Standard Bus without power (i.e., disconnecting the USB end from the computer while leaving the converter connected on Standard Bus). Disturbance on the Standard Bus may occur.

EIA-232/485 Modbus RTU Communications

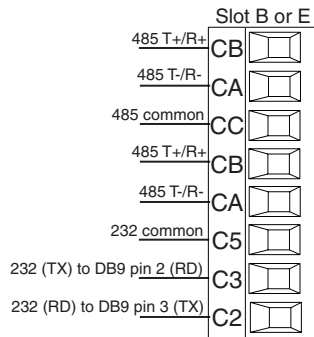

- Wire T-/R- to the A terminal of the EIA-485 port.
- Wire T+/R+ to the B terminal of the EIA-485 port.
- Wire common to the common terminal of the EIA-485 port.
- Do not route network wires with power wires. Connect network wires in daisy-chain fashion when connecting multiple devices in a network.
- A termination resistor may be required. Place a 120 Ω resistor across T+/R+ and T-/R- of last controller on network.
- Do not wire to both the EIA-485 and the EIA-232 pins at the same time.
- Two EIA-485 terminals of T/R are provided to assist in daisy-chain wiring.
- Do not connect more than one PM LEGACY™ Limit controller on an EIA-232 network.
- Maximum number of PM LEGACY™ Limit controllers on a Modbus network is 247.
- Maximum EIA-232 network length: 15 meters (50 feet)
- Maximum EIA-485 network length: 1,200 meters (4,000 feet)
- 1/8th unit load on EIA-485 bus.
- Communications instance 2

Slot B

PM6[L,M] _ _J - [F,2] _ _ _ G_ _

Modbus-IDA Terminal	EIA/TIA-485 Name	Watlow Terminal Label	Function
DO	A	CA or CD	T-/R-
D1	B	CB or CE	T+/R+
common	common	CC or CF	common

EtherNet/IP™, PCCC and Modbus® TCP Communications

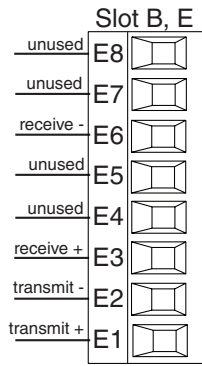

RJ-45 pin	T568B wire color	Signal	Slot B, E
8	brown	unused	E8
7	brown & white	unused	E7
6	green	receive -	E6
5	white & blue	unused	E5
4	blue	unused	E4
3	white & green	receive +	E3
2	orange	transmit -	E2
1	white & orange	transmit +	E1

- Do not route network wires with power wires.
- Connect one Ethernet cable per controller to a 10/100 Mbps Ethernet switch. Both Modbus TCP and EtherNet/IP™ are available on the network.
- Communications instance 2

Slot B

PM6[L,M] _ _ J - [G,3] _ _ _ G _ _

Note:

When changing the fixed IP address cycle module power for new address to take effect.

Ethernet LED Indicators

Viewing the control from the front and then looking on top four LEDs can be seen aligned vertically front to back. The LEDs are identified accordingly: closest to the front reflects the Network (Net) Status, Module (Mod) Status is next, Activity status follows and lastly, the LED closest to the rear of the control reflects the Link status.

Note:

When using Modbus TCP, the Network Status and Module Status LEDs are not used.

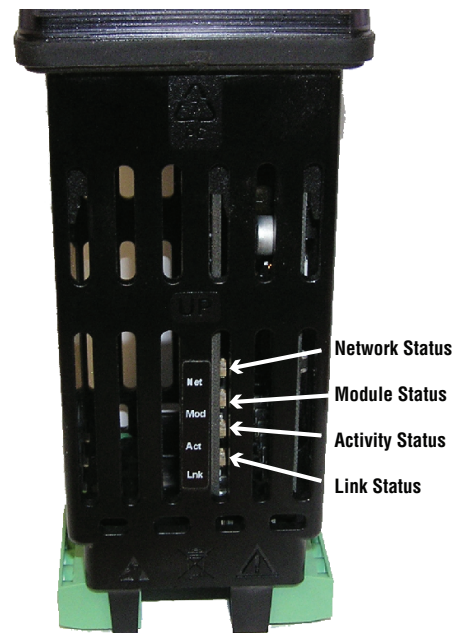

Network Status

Indicator State	Summary	Requirement
Steady Off	Not powered, no IP address	If the device does not have an IP address (or is powered off), the network status indicator shall be steady off.
Flashing Green	No connections	If the device has no established connections, but has obtained an IP address, the network status indicator shall be flashing green.
Steady Green	Connected	If the device has at least one established connection (even to the Message Router), the network status indicator shall be steady green.
Flashing Red	Connection timeout	If one or more of the connections in which this device is the target has timed out, the network status indicator shall be flashing red. This shall be left only if all timed out connections are reestablished or if the device is reset.
Steady Red	Duplicate IP	If the device has detected that its IP address is already in use, the network status indicator shall be steady red.
Flashing Green / Red	Self-test	While the device is performing its power up testing, the network status indicator shall be flashing green / red.

Module Status

Indicator State	Summary	Requirement
Steady Off	No power	If no power is supplied to the device, the module status indicator shall be steady off.
Steady Green	Device operational	If the device is operating correctly, the module status indicator shall be steady green.
Flashing Green	Standby	If the device has not been configured, the module status indicator shall be flashing green.
Flashing Red	Minor fault	If the device has detected a recoverable minor fault, the module status indicator shall be flashing red. NOTE: An incorrect or inconsistent configuration would be considered a minor fault.
Steady Red	Major fault	If the device has detected a non-recoverable major fault, the module status indicator shall be steady red.
Flashing Green / Red	Self-test	While the device is performing its power up testing, the module status indicator shall be flashing green / red.

Activity Status

Indicator State	Summary	Requirement
Flashing Green	Detects activity	If the MAC detects activity, the LED will be flashing green.
Red	- - - -	If the MAC detects a collision, the LED will be red.

Link Status

Indicator State	Summary	Requirement
Steady Off	Not powered, unknown link speed	If the device cannot determine link speed or power is off, the network status indicator shall be steady off.
Green	-----	If cable is wired and connected correctly, the LED will be Green.

DeviceNet™ Communications

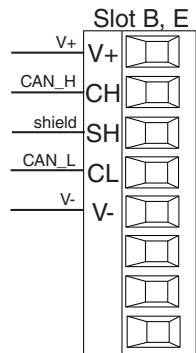

Terminal	Signal	Function
V+	V+	DeviceNet™ power
CH	CAN_H	positive side of DeviceNet™ bus
SH	shield	shield interconnect
CL	CAN_L	negative side of DeviceNet™ bus
V-	V-	DeviceNet™ power return

- Communications instance 2

PM6[L,M] _ _ J - [H,5] _ _ _ G _ _

DeviceNet LED Indicators

Viewing the control from the front and then looking on top two LEDs can be seen aligned vertically front to back. The LED closest to the front is identified as the network (Net) LED where the one next to it would be identified as the module (Mod) LED.

Network Status

Indicator LED	Description
Off	The device is not online and has not completed the duplicate MAC ID test yet. The device may not be powered.
Green	The device is online and has connections in the established state (allocated to a Master).
Red	Failed communication device. The device has detected an error that has rendered it incapable of communicating on the network (duplicate MAC ID or Bus-off).
Flashing Green	The device is online, but no connection has been allocated or an explicit connection has timed out.
Flashing Red	A poll connection has timed out.

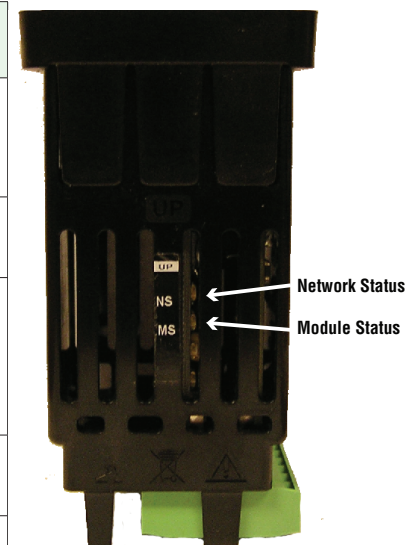

Profibus DP Communications

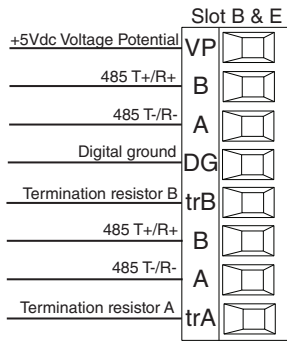

- Wire T-/R- to the A terminal of the EIA-485 port.
- Wire T+/R+ to the B terminal of the EIA-485 port.
- Wire Digital Ground to the common terminal of the EIA-485 port.
- Do not route network wires with power wires. Connect network wires in daisy-chain fashion when connecting multiple devices in a network.
- A termination resistor should be used if this control is the last one on the network.
- If using a 150 Ω cable Watlow provides internal termination. Place a jumper across pins trB and B and trA and A.
- If external termination is to be used with a 150 Ω cable place a 390 Ω resistor across pins VP and B, a 220 Ω resistor across pins B and A, and lastly, place a 390 Ω resistor across pins DG and A.
- Do not connect more than 32 PM LEGACY™ Limit controllers on any given segment.
- Maximum EIA-485 network length: 1,200 meters (4,000 feet)
- 1/8th unit load on EIA-485 bus
- When termination jumpers are in place, there is 392 ohm pull up resistor to 5V and 392 ohm pull down resistor to DP. There is also a 221 ohm resistor between A and B.
- Communications instance 2

PM6[L,M] _ _ J - [J,6] _ _ _ G _ _

Profibus Terminal	EIA/TIA-485 Name	Watlow Terminal Label	Function
VP (Voltage Potential)	- - - -	VP	+5Vdc
B-Line	B	B	T+/R+
A-Line	A	A	T-/R-
DP-GND	common	DG	common

Profibus DP LED Indicators

Viewing the unit from the front and then looking on top of the controller two bi-color LEDs can be seen where only the front one is used. Definition follows:

Closest to the Front

Indicator LED	Description
Red	Profibus network not detected
Red Flashing	Indicates that the Profibus card is waiting for data exchange.
Green	Data exchange mode

Connecting a Computer to PM Controls Using B&B 485 to USB Converter

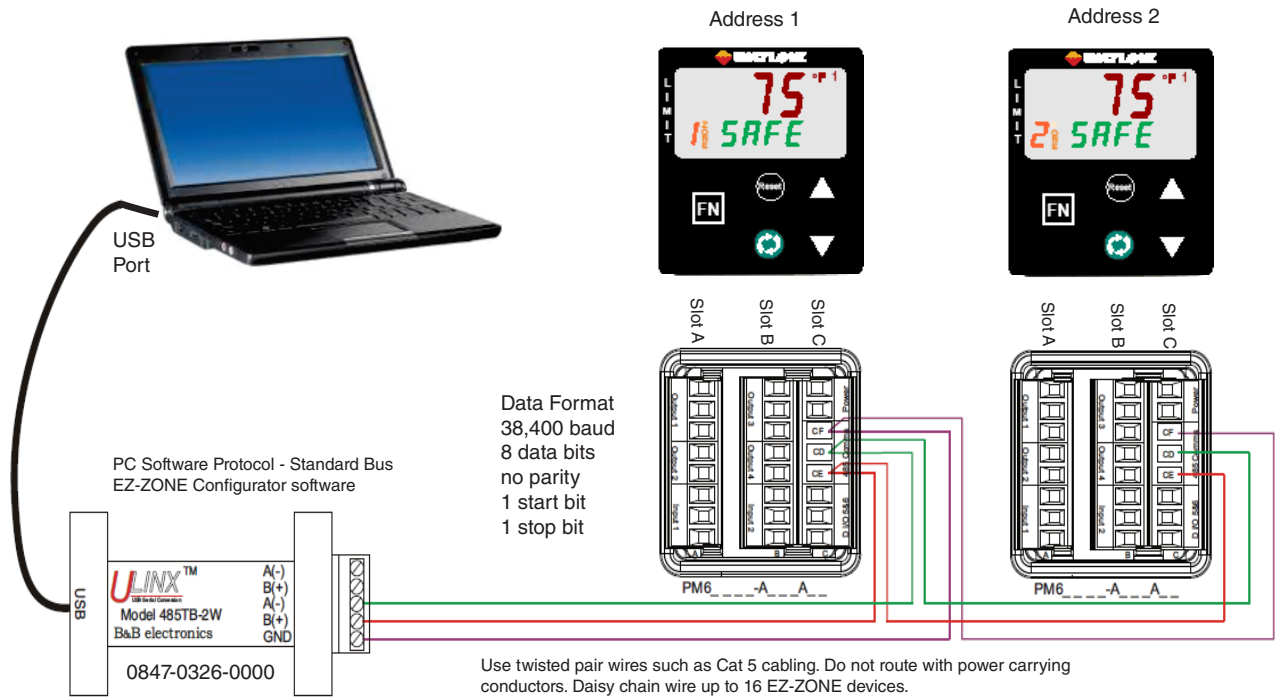

Note:

Do not leave a USB to EIA-485 converter connected to Standard Bus without power (i.e., disconnecting the USB end from the computer while leaving the converter connected on Standard Bus). Disturbance on the Standard Bus may occur.

Note:

When connecting the USB converter to the PC it is suggested that the Latency Timer be changed from the default of 16 msec to 1 msec. Failure to make this change may cause communication loss between the PC running PM LEGACY™ Limit Configurator software and the control.

To modify Latency Timer settings follow the steps below:

1. Navigate to Device Manager.
2. Double click on Ports.
3. Right click on the USB serial port in use and select Properties.
4. Click the tab labeled Port settings and then click the Advance button.

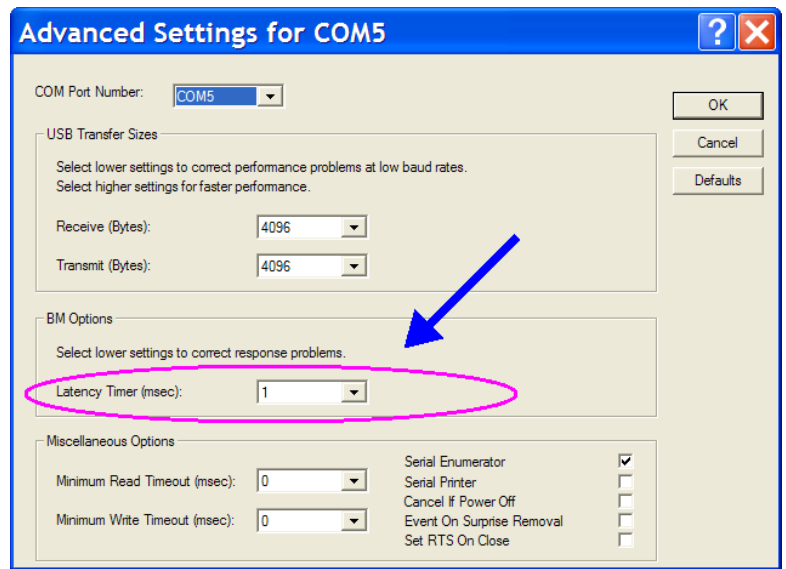

3

Chapter 3: Keys & Displays

Keys & Displays 16th DIN LIMIT Controller

Zone Display:

When [Zone] (found in the Factory Page) is set to on, indicates the controller zone.

[1] to [9] = zones 1 to 9

[A] = zone 10 [E] = zone 14

[b] = zone 11 [F] = zone 15

[C] = zone 12 [h] = zone 16

[d] = zone 13

Lower Display:

Indicates the current state of the limit [FRIL] or [SAFE].

Function Key:

Programmable by user to activate a function.

RESET Key:

Press to reset limit after a trip condition has been cleared.

Upper Display:

On power up, displays the process value, otherwise displays the value of the parameter in the lower display.

Temperature Units

Indicator Lights:

Indicates whether the temperature is displayed in Fahrenheit or Celsius.

Output Activity:

Number lights indicate activity of outputs 1 and 2.

Communications Activity:

Flashes when another device is communicating with this controller.

Up and Down Keys:

Changes limit set points when displayed. Changes menu inside pages. Inside menus, changes the selected setting in left display

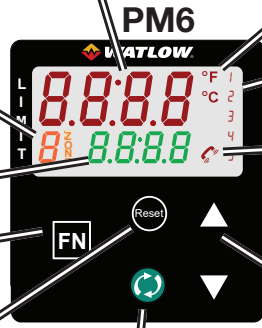

Advance Key: Advances through menu prompts.

PM3 32nd DIN LIMIT Controller

Left Display: Home at beginning displays process value (PV). Entering into menus displays the value or setting of parameter

Output Activity: Indicates activity of outputs 1 & 2, dio 5 & 6

Right Display: Home at beginning displays limit status. Displays page name when entering pages. Entering into menus displays the parameter name

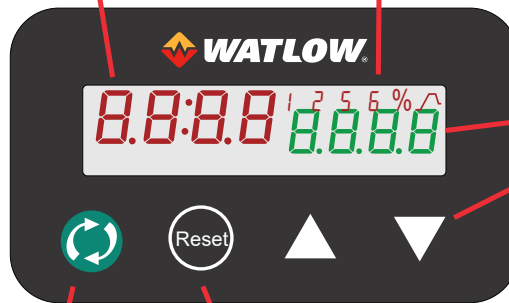

Advance Key: Advances through menu prompts.



Reset Key: Press to reset limit after a trip condition has been cleared.





Up and Down Keys: Changes limit set points when displayed. Changes menu inside pages. Inside menus, changes the selected setting in left display

Responding to a Displayed Message

An active message will cause the display to toggle between the normal settings and the active message in the upper display and *Attn* in the green display.

Your response will depend on the message and the controller settings. Some messages, such as Ramping and Tuning, indicate that a process is underway. If the message was generated by a latched alarm and the condition no longer exists or if an alarm has silencing enabled it can be silenced simply by pushing the Reset key . Alternatively, use the method below to view all and then clear.

Push the Advance Key to display *Err* in the red display and the message source (such as *ALh1*) in the lower display. Use the Up or Down keys   to scroll through possible responses, such as Clear *Clr* or Silence *Sil*, then push the Advance or Reset key to execute the action. See the Home Page for further information on the Attention Codes.



Display	Parameter Name Description	Range	Appears If
<i>Attn</i>	<p>Attention</p> <p>An active message will cause the display to toggle between the normal settings and the active message in the upper display and <i>Attn</i> in the green display. Your response will depend on the message and the controller settings. Some messages, such as Ramping and Tuning, indicate that a process is underway. If the message was generated by a latched alarm, the message can be cleared when the condition no longer exists. If an alarm has silencing enabled, it can be silenced.</p> <ol style="list-style-type: none"> 1. Push the Advance Key to display <i>Err</i> in the red display and the message source (such as <i>ALh1</i>) in the lower display. 2. Use the Up or Down keys   to scroll through possible responses, such as Clear <i>Clr</i> or Silence <i>Sil</i>. 3. Press the Advance Key or Reset  button to execute the action. <p>Alternatively, rather than scrolling through all messages simply push the Reset  button to generate a clear.</p>	<p><i>ALL1 ALL2 ALL3 ALL4</i> Alarm Low 1 to 4</p> <p><i>ALh1 ALh2 ALh3 ALh4</i> Alarm High 1 to 4</p> <p><i>ALE1 ALE2 ALE3 ALE4</i> Alarm Error 1 to 4</p> <p><i>Err1</i> Error Input 1</p> <p><i>LL1</i> Limit Low 1</p> <p><i>Lh1</i> Limit High 1</p> <p><i>LE1</i> Limit Error 1</p> <p><i>uALh</i> Value to high to be displayed in 4 digit LED display >9999</p> <p><i>uALL</i> Value to low to be displayed in 4 digit LED display <-1999</p>	An alarm or error message is active.

4

Chapter 4: Home Page

Default Home Page Parameters

Watlow's patented user-defined menu system improves operational efficiency. The user-defined Home Page provides you with a shortcut to monitor or change the parameter values that you use most often. The default Home Page is shown on the following page. When a parameter normally located in the Setup Page or Operations Page is placed in the Home Page, it is accessible through both. If you change a parameter in the Home Page, it is automatically changed in its original page. If you change a parameter in its original page it is automatically changed in the Home Page.

Use the Advance Key to step through the other parameters. When not in pairs, the parameter prompt will appear in the green display, and the parameter value will appear in the upper display. You can use the Up or Down keys   to change the value of writable parameters, just as you would in any other menu.

Note:

If a writable value is placed on the red display and is paired with another read only parameter on the green display, the arrow keys affect the setting of the red display. If two writable parameters are paired, the arrow keys affect the green display.

- The Attention *Attn* parameter appears only if there is an active message. An example of an active message could be a Input Error *Err!*.
- If a sensor failure has occurred, dashes *----* will be displayed in the red display.

Navigating the PM LEGACY™ Limit Controller PM6 Shown, Applies to All Models



Home Page from anywhere: Press the Reset  key for two seconds to return to the Home Page.



Operations Page from Home Page: Press both the Up and Down key  for three seconds.



Setup Page from Home Page: Press both the Up and Down key  for six seconds.

Note: Keys must be held continuously until *SEt* is displayed in green. If keys are released when *oPEr* is displayed, press the Reset key or reset key to exit and repeat until *SEt* is displayed.



Factory Page from Home Page: Press both the Advance and Reset  keys for six seconds.

Changing the Set Point

From the default Home Page the Limit Set Points, high and low, can be changed. If high and low limits have been configured push the Advance key one time and the Low Limit Set Point *LLS 1* prompt will appear in the green display. Pushing the Up or Down arrow keys **▲▼** will change the set point. Once done, simply push the Advance key to display the High Limit Set Point *LhS 1*. To change simply push the Up or Down arrow keys **▲▼**.

Modifying the Home Page

Follow the steps below to modify the Home Page:

1. Push and hold the Advance key and the Reset key for approximately six seconds. Upon entering the Factory Page the first menu will be the Custom Menu *CuSt*.
2. Push the Advance key where the green display will show *CuSt* and the red display will show *!*.
3. Push the Advance button where the prompt for the Custom *CuSt* will be displayed in red and Parameter *PRr* in the green display.

There are twenty positions available that can be customized.

4. Pushing the Up or Down arrow keys **▲▼** will allow for a customized selection to be made (see list of available parameters below).

This list shows what would be displayed at the home page for the parameter when selected as a choice in the custom page. The custom page list of choices and instances are to be selected in two steps. First the choice, press advance and then the instance show.

Custom Menu Parameter Options	
Description	Prompt *
All Models	
None	Blank
Analog Input Value	<i>A_{in} 1</i>
Cal In Offset	<i>uCA 1</i>
Display Units	<i>C_F 1</i>
Load Parameter Set	<i>USr. 1 USr. 2</i>
Low Set Point	<i>ALo 1 ALo 2 ALo 3 ALo 4</i>
High Set Point	<i>Ah 1 1 Ah 1 2 Ah 1 3 Ah 1 4</i>
Hysteresis	<i>AhY 1 AhY 2 AhY 3 AhY 4</i>
Low Limit Set Point	<i>LLS 1</i>
High Limit Set Point	<i>LhS 1</i>
Hysteresis	<i>LhY 1</i>
Limit Status	<i>LSt 1</i>

* The numerical digit shown in the prompts above (last digit), represents the parameter instance and can be greater than one.

Modifying the Display Pairs

The Home Page, being a customized list of as many as 20 parameters, can be configured in pairs of up to 10 via the Display Pairs *dPr5* prompt found in the Global Menu *9LbL* (Setup Page). The listing in the table that follows represents the Limit default Home page. It is important to note that some of the prompts shown may not appear simply because the feature is not being used or is turned off. As an example, the prompt shown in position 3 (Limit Low Set Point, *LLS1*) will not appear unless the Limit Sides is set for low or both found on the Setup page under the Limit Menu.

Home Page Default Parameters			
Custom Menu Number	Home Page Display (Defaults)	Parameter Name	Custom Menu Display (Defaults)
1 (Upper or left display)	Numerical value	Active Process Value	<i>Pro</i>
2 (Lower or right display)	<i>SAFE</i> or <i>FAIL</i>	Limit Status	<i>LSL</i>
3	Numerical value	Low Limit Set Point	<i>LLS1</i>
4	Numerical value	High Limit Set Point	<i>LHS1</i>
5 to 20	(skipped)		<i>nonE</i>

Note:

When the Limit is in a default state (as shipped from factory), the display will flash where the red display will show the Process Value and the green display will flash *ALtEr* and *FAIL*.

As stated above, the user can define ten pairs of prompts to appear on the display every time the Advance key is pushed. In a default state, the Display Pairs *dPr5* prompt (Setup Page under the Global Menu) is equal to one with the first pair displayed as is defined in the Home Page table above. If the Display Pairs prompt were to be changed to two, pushing the Advance key one time would cause the display to show the Low Limit Set Point on the top and the High Limit Set Point on the bottom reflecting position 3 and 4 respectively.

Note:

Both of these parameters are writable and being paired in this manner only the High Limit Set Point can be changed. Pairing two writable prompts will only allow for the bottom one to be changed. On the other hand, if a writable value is placed on the red display and is paired with another read only parameter on the green display, the arrow keys affect the setting of the red display.

The display can be configured to scroll through the Display Pairs by going to the Setup Page under the Global Menu and changing the Display Time *dt* prompt to something greater than 0. If set to 2, the display will scroll through the pairs every 2 seconds starting with Custom Menu Pair 1 and 2, 3 and 4, etc..

Conventions Used in the Menu Pages

To better understand the menu pages that follow review the naming conventions used. When encountered throughout this document, the word “default” implies as shipped from the factory.

Each page (Operations, Setup, Profile and Factory) and their associated menus have identical headers defined below:

Header Name	Definition
Display	Visually displayed information from the control.
Parameter Name	Describes the function of the given parameter.
Range	Defines options available for this prompt, i.e., min/max values (numerical), yes/no, etc... (further explanation below).
Default	Values as delivered from the factory.
Modbus Relative Address	Identifies unique parameters using either the Modbus RTU or Modbus TCP protocols (further explanation below).
CIP (Common Industrial Protocol)	Identifies unique parameters using either the DeviceNet or EtherNet/IP protocol (further explanation below).
Profibus Index	Identifies unique parameters using Profibus DP protocol (further explanation below).
Parameter ID	Identifies unique parameters used with other software such as, LabVIEW.
Data Type R/W	uint = Unsigned 16 bit integer dint = Signed 32-bit, long string = ASCII (8 bits per character) float = IEEE 754 32-bit RWES = Readable Writable EEPROM (saved) User Set (saved)

Display

Visual information from the control is displayed to the observer using a fairly standard 7 segment display. Due to the use of this technology, several characters displayed need some interpretation, see the list below:

<i>1</i> = 1	<i>7</i> = 7	<i>c</i> , <i>£</i> = c	<i>i</i> = i	<i>o</i> = o	<i>u</i> , <i>U</i> = u
<i>2</i> = 2	<i>8</i> = 8	<i>d</i> = d	<i>J</i> = J	<i>P</i> = P	<i>v</i> , <i>V</i> = v
<i>3</i> = 3	<i>9</i> = 9	<i>E</i> = E	<i>H</i> = K	<i>q</i> = q	<i>W</i> = W
<i>4</i> = 4	<i>0</i> = 0	<i>F</i> = F	<i>L</i> = L	<i>r</i> = r	<i>y</i> = y
<i>5</i> = 5	<i>A</i> = A	<i>g</i> = g	<i>M</i> = M	<i>S</i> = S	<i>Z</i> = Z
<i>6</i> = 6	<i>b</i> = b	<i>h</i> = h	<i>n</i> = n	<i>t</i> = t	

Range

Within this column notice that on occasion there will be numbers found within parenthesis. This num-

ber represents the enumerated value for that particular selection. Range selections can be made simply by writing the enumerated value of choice using any of the available communications protocols. As an example, turn to the Setup Page and look at the Analog Input *AI* menu and then the Sensor Type *SEN* prompt. To turn the sensor off using Modbus simply write the value of 62 (off) to register.

Communication Protocols

When using a communications protocol in conjunction with the PM LEGACY™ Limit there are two possible ports (instances) used. Port 1 or instance 1 is always dedicated to Standard Bus communications. This same instance can also be used for Modbus RTU if ordered. Depending on the controller part number, port 2 (instance 2) can be used with Modbus, CIP and Profibus. For further information read through the remainder of this section.

Modbus Introduction to the Modbus Protocol

Gould Modicon, now called AEG Schneider, first created the protocol referred to as “Modbus RTU” used in process control systems. Modbus provides the advantage of being extremely reliable in exchanging information, a highly desirable feature for industrial data communications. This protocol works on the principle of packet exchanges. The packet contains the address of the controller to receive the information, a command field that says what is to be done with the information, and several fields of data. Each PM parameter has a unique Modbus address and they can be found in the following Operations, Setup and Factory Pages.

All Modbus registers are 16-bits and as displayed in this User’s Guide are relative addresses (actual). For parameters listed as float, notice that only one (low order) of the two registers is listed; this is true throughout this document. By default, the low order word contains the two low bytes of the 32-bit parameter. As an example, look in the Operations Page under the Analog Input Menu for the Analog Input Value. Find the column identified in the header as Modbus and notice that it lists register. Because this parameter is a float it is actually represented by registers (low order bytes) and (high order bytes). The Modbus specification does not dictate which register should be high or low order therefore, Watlow provides the user the ability to swap this order (Setup Page, *CONF* Menu) from the default low/high *LoHi* to high/low *HiLo*.

Note:

Notice in the column identified as Modbus the reference to Map 1 and Map 2 registers for each of the various parameters. For all new applications, select Modbus Map 2 and use Map 2 listed values. For backwards comparability with older PMs, use Modbus Map 1 if needed. If the new functions of this product line are not to be used, Map 1 (LEGACY™ PM controls) Modbus registers will be sufficient. The Modbus register mapping *MAP* can be changed in the Setup Page under the *CONF* Menu. This setting will apply across the control. We recommend using Map 2 for all new applications. Use Map 1 only if it is desired to maintain backwards compatibility.

It should also be noted that some of the cells in the Modbus column contain wording pertaining to an offset. Several parameters in the control contain more than one instance, such as, alarms (4). The Modbus register shown always represents instance one. Take for an example the Silence Alarm parameter found in the Setup Page under the Alarm Menu. Instance one of Map 1 is shown as address 1490 and +50 is identified as the offset to the next instance. If there was a desire to read or write to instance 3, simply add 100 to 1490 to find its address, in this case, the instance 3 address for Silence Alarm is 1590.

The Modbus communications instance can be either 1 or 2 depending on the part number.
Instance 1:

PM _____ - [1] A _____

Instance 2:

PM _____ - [2] A _____

To learn more about the Modbus protocol point your browser to <http://www.modbus.org>.

Common Industrial Protocol (CIP) Introduction to CIP

Both DeviceNet and EtherNet/IP use open object based programming tools and use the same addressing scheme. In the following menu pages notice the column header identified as CIP. There you will find the Class, Instance and Attribute in hexadecimal, (decimal in parenthesis) which makes up the addressing for both protocols.

The CIP communications instance will always be instance 2.

Data Types Used with CIP

int	= Signed 16-bit integer
uint	= Signed 16-bit integer
dint	= Signed 32-bits, long
real	= Float, IEEE 754 32-bit
string	= ASCII, 8 bits per character
sint	= Signed 8 bits , byte

To learn more about the DeviceNet and EtherNet/IP protocol point your browser to <http://www.odva.org>.

Profibus DP

To accommodate for Profibus DP addressing the following menus contain a column identified as Profibus Index. Data types used in conjunction with Profibus DP can be found in the table below.

The Profibus communications instance will always be instance 2.

real	= Float, IEEE 754 32-bit
int	= Signed 16-bit integer
byte	= 8-bits

To learn more about the Profibus DP protocol point your browser to <http://www.profibus.org>

5

Chapter 5: Operations

PM Operation Page Parameters

To navigate to the Operations Page, follow the steps below:

1. From the Home Page, press both the Up and Down keys **▲▼** for three seconds. *A I* will appear in the red display and *oPEr* will appear in the green display.
2. Press the Up or Down key **▲▼** to view available menus.
3. Press the Advance Key to enter the menu of choice.
4. If a sub-menu exists (more than one instance), press the Up or Down key **▲▼** to select and then press the Advance Key to enter.
5. Press the Up or Down key **▲▼** to move through available menu prompts.
6. Press the Reset Key to move backwards through the levels: parameter to sub-menu, sub-menu to menu, menu to Home Page.
7. Press and hold the Reset Key for two seconds to return to the Home Page.

On the following pages, top level menus are identified with a yellow background color.

Note:

Some of these menus and parameters may not appear, depending on the controller's options. See model number information in the Appendix for more information. If there is only one instance of a menu, no sub-menus will appear.

Note:

Some of the listed parameters may not be visible. Parameter visibility is dependent upon controller part number.

<i>A I</i>		<i>L I M</i>	
<i>oPEr</i> Analog Input Menu		<i>oPEr</i> Limit Menu	
<i>I</i>		<i>I</i>	
<i>A I</i> Analog Input (1 to 2)		<i>L I M</i> Limit	
<i>A I n</i> Analog Input Value		<i>LLS</i> Low Limit Set Point	
<i>IEr</i> Input Error		<i>LhS</i> High Limit Set Point	
<i>iCR</i> Calibration Offset		<i>LEr</i> Clear Limit	
		<i>LSt</i> Limit Status	
<i>d i o</i>			
<i>oPEr</i> Digital Input/Output Menu		<i>AL M</i>	
<i>I</i>		<i>oPEr</i> Alarm Menu	
<i>d i o</i> Digital Input/Output (5 to 6)		<i>I</i>	
<i>d o S</i> Output State		<i>AL M</i> Alarm (1 to 4)	
<i>d i S</i> Input State		<i>ALo</i> Low Set Point	
<i>E i S</i> Event Status		<i>Ah i</i> High Set Point	
		<i>ACLr</i> Clear Alarm	
		<i>AS i r</i> Silence Alarm	
		<i>AS t</i> Alarm State	

Operations Page

Display	Parameter Name Description	Range	Default	Modbus Relative Address	CIP Class Instance Attribute hex (dec)	Pro-fib-us Index	Pa-ram-eter ID	Data Type and Access **
<p><i>R, aPEr</i></p> <h3>Analog Input Menu</h3>								
<i>R, in</i> Ain	<p>Analog Input</p> <p>Analog Input Value</p> <p>View the process value.</p> <p>Note:</p> <p>Ensure that the Input Error (below) indicates no error (61) when reading this value using a field bus protocol. If an error exists, the last known value prior to the error occurring will be returned.</p>	-1,999.000 to 9,999.000°F or units -1,128.000 to 5,537.000°C	----	Instance 1 Map 1 Map 2 360 360	0x68 (104) 1 1	0	4001	float R
<i>iEr</i> i.Er	<p>Analog Input</p> <p>Input Error</p> <p>View the cause of the most recent error. If the <i>REtEn</i> message is <i>Er.i1</i>, this parameter will display the cause of the input error.</p> <p><i>Er.i1</i> = input 1 <i>Er.i2</i> = input 2</p>	<p><i>nonE</i> None (61)</p> <p><i>OPEn</i> Open (65)</p> <p><i>Shrt</i> Shorted (127)</p> <p><i>Ei</i> Measurement Error (140)</p> <p><i>ECAL</i> Bad Calibration Data (139)</p> <p><i>ErAb</i> Ambient Error (9)</p> <p><i>Ertd</i> RTD Error (141)</p> <p><i>FRiL</i> Fail (32)</p> <p><i>NSrc</i> Not Sourced (246)</p>	----	Instance 1 Map 1 Map 2 362 362	0x68 (104) 1 2	1	4002	uint R
<i>iCA</i> i.CA	<p>Analog Input</p> <p>Calibration Offset</p> <p>Offset the input reading to compensate for lead wire resistance or other factors that cause the input reading to vary from the actual process value.</p>	-1,999.000 to 9,999.000°F or units -1,110.555 to 5,555.000°C	0.0	Instance 1 Map 1 Map 2 382 382	0x68 (104) 1 0xC (12)	2	4012	float RWES

** R: Read, W: Write, E: EEPROM, S: User Set

Operations Page

Display	Parameter Name Description	Range	Default	Modbus Relative Address	CIP Class Instance Attribute hex (dec)	Pro-fib-us Index	Pa-ram-eter ID	Data Type and Access **
<div style="display: flex; justify-content: space-between;"> d i o o P E r </div> <h3>Digital Input/Output Menu</h3>								
do.S	Digital Output (5 to 6) Output State View the state of this output.	oFF Off (62) oN On (63)	----	Instance 5 Map 1 Map 2 1012 1132 Offset to next instance equals +30	0x6A (106) 5 to 6 7	46	6007	uint R
di.S	Digital Input (5 to 6) Input State View this event input state.	oFF Off (62) oN On (63)	----	Instance 5 Map 1 Map 2 1020 1140 Offset to next instance equals +30	0x6A (106) 5 to 6 0x0B (11)	----	6011	uint R
Ei.S	Digital Input (5 to 6) Event Status View this event input state.	, Rct Inactive (41) Rct Active (5)	----	Instance 5 Map 1 Map 2 1408 1648 Offset to next instance equals +20	0x6E (110) 5 to 6 5	140	10005	uint R
No Display	EZ-Key/s (1 to 2) Event Status View this event input state.	, Rct Inactive (41) Rct Active (5)	----	Instance 1 Map 1 Map 2 1328 1568 5 Instance 2 Map 1 Map 2 1348 1588	0x6E (110) 3 to 4 5	140	10005	uint R
<div style="display: flex; justify-content: space-between;"> L i m o P E r </div> <h3>Limit Menu</h3>								
LL.S	Limit Low Limit Set Point Set the low process value that will trigger the limit.	-1,999.000 to 9,999.000°F or units -1,128.000 to 5,537.000°C	0.0°F or units -18.0°C	Instance 1 Map 1 Map 2 684 724 3	0x70 (112) 1 3	38	12003	float RWES
Lh.S	Limit High Limit Set Point Set the high process value that will trigger the limit.	-1,999.000 to 9,999.000°F or units -1,128.000 to 5,537.000°C	0.0°F or units -18.0°C	Instance 1 Map 1 Map 2 686 726 4	0x70 (112) 1 4	39	12004	float RWES
** R: Read, W: Write, E: EEPROM, S: User Set								

Operations Page

Display	Parameter Name Description	Range	Default	Modbus Relative Address	CIP Class Instance Attribute hex (dec)	Pro-fib-us Index	Pa-ram-eter ID	Data Type and Access **
<i>LCr</i> LCr	Limit (1) Clear Limit Clear limit once limit condition is cleared.	Clear (0) No Change (255)	----	Instance 1 Map 1 Map 2 680 720	0x70 (112) 1 1	----	12014	uint W
<i>LSt</i> L.St	Limit (1) Limit Status Reflects whether or not the limit is in a safe or failed mode..	<i>FRIL</i> Fail (32) <i>SAFE</i> Safe (1667)	----	Instance 1 Map 1 Map 2 ----- 744	0x70 (112) 1 0x0D (13)	----	12013	uint R
No Display	Limit Limit State Clear limit once limit condition is cleared.	Off (62) None (61) Limit High (51) Limit Low (52) Error (225)	----	Instance 1 Map 1 Map 2 690 730	0x70 (112) 1 6	----	12006	uint R

ALP7

oPEr

Alarm Menu

<i>ALo</i> A.Lo	Alarm (1 to 4) Low Set Point If Type (Setup Page, Alarm Menu) is set to: Process - set the process value that will trigger a low alarm.	-1,999.000 to 9,999.000°F or units -1,128.000 to 5,537.000°C	32.0°F or units 0.0°C	Instance 1 Map 1 Map 2 1482 1882 Offset to next instance (Map 1) equals +50 Offset to next instance (Map 2) equals +60	0x6D (109) 1 to 4 2	18	9002	float RWES
<i>Ahi</i> A.hi	Alarm (1 to 4) High Set Point If Type (Setup Page, Alarm Menu) is set to: Process - set the process value that will trigger a high alarm.	-1,999.000 to 9,999.000°F or units -1,128.000 to 5,537.000°C	300.0 °F or units 150.0 °C	Instance 1 Map 1 Map 2 1480 1880 Offset to next instance (Map 1) equals +50 Offset to next instance (Map 2) equals +60	0x6D (109) 1 to 4 1	19	9001	float RWES

** R: Read, W: Write, E: EEPROM, S: User Set

Operations Page

Display	Parameter Name Description	Range	Default	Modbus Relative Address	CIP Class Instance Attribute Hex (dec)	Pro-fib-us Index	Pa-ram-eter ID	Data Type and Access **
<i>RELR</i> A.Clr	Alarm (1 to 4) Clear Alarm Write to this register to clear an alarm	<i>RELR</i> Clear (1003) <i>IGNR</i> Ignore (204)	----	Instance 1 Map 1Map 2 1504 1904 Offset to next instance (Map1 1 equals +50, Map 2 equals +60)	0x6D (109) 1 to 4 0x0D (13)	----	9026	uint W
<i>RESR</i> A.Sir	Alarm (1 to 4) Silence Alarm Write to this register to silence an alarm	<i>SIL</i> Silence (1010)		Instance 1 Map 1Map 2 1506 1906 Offset to next instance (Map1 1 equals +50, Map 2 equals +60)	0x6D (109) 1 to 4 0x0E (14)	----	9027	uint W
<i>RESL</i> A.St	Alarm (1 to 4) State Current state of alarm	Startup (88) None (61) Blocked (12) Alarm low (8) Alarm high (7) Error (28)	----	Instance 1 Map 1Map 2 1496 1896 Offset to next instance (Map1 1 equals +50, Map 2 equals +60)	0x6D (109) 1 to 4 9	----	9009	uint R
No Display	Alarm (1 to 4) Alarm Clearable Indicates if alarm can be cleared.	No (59) Yes (106)		Instance 1 Map 1Map 2 1502 1902 Offset to next instance (Map1 1 equals +50, Map 2 equals +60)	0x6D (109) 1 to 4 0xC (12)	----	9012	uint R
No Display	Alarm (1 to 4) Alarm Silenced Indicates if alarm is silenced.	No (59) Yes (106)	----	Instance 1 Map 1Map 2 1500 1900 Offset to next instance (Map1 1 equals +50, Map 2 equals +60)	0x6D (109) 1 to 4 0x0B (11)	----	9011	uint R

** R: Read, W: Write, E: EEPROM, S: User Set

Operations Page

Display	Parameter Name Description	Range	Default	Modbus Relative Address	CIP Class Instance Attribute hex (dec)	Pro-fib-us In-dex	Pa-ram-eter ID	Data Type and Access **
No Display	Alarm (1 to 4) Alarm Latched Indicates if alarm is latched.	No (59) Yes (106)	----	Instance 1 Map 1Map 2 1498 1898 Offset to next instance (Map1 1 equals +50, Map 2 equals +60)	0x6D (109) 1 to 4 0x0A (10)	----	9010	uint R

** R: Read, W: Write, E: EEPROM, S: User Set

6

Chapter 6: Setup Page

Navigating the Setup Page

To navigate to the Setup Page follow the steps below:

1. From the Home Page, press and hold both the Up or Down keys **▲▼** for six seconds. *R i* will appear in the red display and *SEt* will appear in the green display. If the up and down arrow keys are released where *oPEr* appears in the green display, simply press and hold those same keys for an additional 3 seconds.
2. Press the Up or Down key **▲▼** to view available menus.
3. Press the Advance Key to enter the menu of choice.
4. If a sub-menu exists (more than one instance), press the Up or Down key **▲▼** to select and then press the Advance Key to enter.
5. Press the Up or Down key **▲▼** to move through available menu prompts.
6. Press the Reset Key to move backwards through the levels: parameter to sub-menu, sub-menu to menu, menu to Home Page.
7. Press and hold the Reset Key for two seconds to return to the Home Page.

On the following pages, top level menus are identified with a yellow background color.

Note:

Some of these menus and parameters may not appear, depending on the controller's options. See model number information in the Appendix for more information. If there is only one instance of a menu, no sub-menus will appear.

Note:

Some of the listed parameters may not be visible. Parameter visibility is dependent upon controller part number.

<i>R i</i>			
<i>SEt</i> Analog Input Menu			
<i>i</i>		<i>PEE</i>	Process Error Enable
<i>R i</i>	Analog Input (1 to 2)	<i>PEL</i>	Process Error Low Value
<i>SEn</i>	Sensor Type	<i>t.C</i>	Thermistor Curve
<i>L in</i>	TC Linearization	<i>r.r</i>	Resistance Range
<i>r.t.L</i>	RTD Leads	<i>F iL</i>	Filter
<i>Un it</i>	Units	<i>iEr</i>	Input Error Latching
<i>SLo</i>	Scale Low	<i>dEC</i>	Display Precision
<i>Sh i</i>	Scale High	<i>i.CA</i>	Calibration Offset *
<i>r.Lo</i>	Range Low	<i>R in</i>	Analog Input Value *
<i>r.h i</i>	Range High	<i>iEr</i>	Input Error *
* These parameters/prompts are available with firmware revisions 11.0 and above.			

<i>gLBt</i>	
<i>SEt</i> Global Menu	
<i>gLBt</i>	Global
<i>C _F</i>	Display Units
<i>RCLF</i>	AC Line Frequency
<i>CLEd</i>	Communications LED Action
<i>zOnE</i>	Zone
<i>dPrS</i>	Display Pairs
<i>dEt i</i>	Display Time
<i>USr.S</i>	Save Settings As
<i>USr.r</i>	Restore Settings From

d io	
SEt Digital Input/Output Menu	
5	
dio	Digital Input/Output (5 to 6)
d ir	Direction
F n	Function
F i	Output Function Instance
LEu	Active Level
F n	Action Function
F i	Function Instance

o t P t	
SEt Output Menu	
1	
o t P t	Output (1 to 4)
F n	Function
F i	Output Function Instance
o t P t	Output Process 3
o t Y	Type
F n	Function
F i	Output Function Instance
SLo	Scale Low
Sh i	Scale High
r.Lo	Range Low
r.h i	Range High
a c R	Calibration Offset

AL P P	
SEt Alarm Menu	
1	
AL P P	Alarm (1 to 4)
R t Y	Type
S r A	Alarm Source
i.SA	Alarm Source Instance
R h Y	Hysteresis
AL G	Logic
RS d	Sides
RL o	Low Set Point *
R h i	High Set Point *
RLA	Latching
R b L	Blocking
RS i	Silencing
R d SP	Display
a.dL	Delay Time
RCL r	Clear Alarm *
RS i r	Silence Alarm *
RS t	Alarm State *

L i P P	
SEt Limit Menu	
L.s d	Sides
L h Y	Hysteresis
S P L h	Maximum Set Point
S P L L	Minimum Set Point
L h S	High Limit Set Point *
L L S	Low Limit Set Point *
S F n A	Source Function A*
S i A	Source Instance A*
LE r	Clear Limit *
LS t	Limit Status *

* These parameters/prompts are available with firmware revisions 11.0 and above.

F U n	
SEt Variable Menu	
1	
F U n	Function Key (1 to 2)
LEu	Active Level
F n	Action Function
F i	Function Instance

* These parameters/prompts are available with firmware revisions 11.0 and above.

C O P P					
SEt Communications Menu					
1		i.PF3	IP Fixed Address Part 3	E i.PE	EtherNet/IP Enable
C O P P	Communications (1to 2)	i.PF4	IP Fixed Address Part 4	R a n b	CIP Implicit Assembly Output Member Quantity
P C o L	Protoco	i.P5 1	IP Fixed Subnet Part 1	R i n b	CIP Implicit Assembly Input Member Quantity
R d S	Standard Bus Address	i.P5 2	IP Fixed Subnet Part 2	R d d	DeviceNet™ Node Address
R d P P	Modbus Address	i.P5 3	IP Fixed Subnet Part 3	B R U d	Baud Rate DeviceNet™
b R U d	Baud Rate	i.P5 4	IP Fixed Subnet Part 4	F C E	DeviceNet™ Quick Connect Enable
P R r	Parity	i.P9 1	Fixed IP Gateway Part 1	P R d d	Profibus Address
	Modbus Word Order	i.P9 2	Fixed IP Gateway Part 2	RL o c	Profibus Address Lock
i.P P P	IP Address Mode	i.P9 3	Fixed IP Gateway Part 3	S t A t	Profibus Status
i.P F 1	IP Fixed Address Part 1	i.P9 4	Fixed IP Gateway Part 4	C _ F	Display Units
i.P F 2	IP Fixed Address Part 2	P P b E	Modbus TCP Enable		Data Map
				n U S	Non-Volatile Save

* These parameters/prompts are available with firmware revisions 11.0 and above.

Setup Page

Display	Parameter Name Description	Range	Default	Modbus Relative Address	CIP - Class Instance Attribute hex (dec)	Pro-fibus Index	Pa-rame-ter ID	Data Type and Access **
<p><i>R</i>, <i>SEt</i></p> <p>Analog Input Menu</p>								
<i>SEn</i> SEn	Analog Input Sensor Type Set the analog sensor type to match the device wired to this input. Note: There is no open sensor protection for process inputs.	<i>oFF</i> Off (62) <i>tC</i> Thermocouple (95) <i>mV</i> Millivolts (56) <i>vdc</i> Volts dc (104) <i>mA</i> Milliamps dc (112) <i>RTD 100</i> RTD 100 Ω (113) <i>RTD 1000</i> RTD 1,000 Ω (114) <i>Pot</i> Potentiometer 1 kΩ (155) <i>tHr</i> Thermistor (229)	Thermo-couple or Thermistor	Instance 1 Map 1 Map 2 368 368	0x68 (104) 1 5	3	4005	uint RWES
<i>Lin</i> Lin	Analog Input TC Linearization Set the linearization to match the thermocouple wired to this input.	<i>B</i> B (11) <i>K</i> K (48) <i>C</i> C (15) <i>N</i> N (58) <i>D</i> D (23) <i>R</i> R (80) <i>E</i> E (26) <i>S</i> S (84) <i>F</i> F (30) <i>T</i> T (93) <i>J</i> J (46)	J	Instance 1 Map 1 Map 2 370 370	0x68 (104) 1 6	4	4006	uint RWES
<i>rt.L</i> rt.L	Analog Input RTD Leads Set to match the number of leads on the RTD wired to this input.	<i>2</i> 2 (1) <i>3</i> 3 (2)	2	Instance 1 Map 1 Map 2 372 372	0x68 (104) 1 7	----	4007	uint RWES
<i>Unit</i> Unit	Analog Input Units Set the type of units the sensor will measure.	<i>ATP</i> Absolute Temperature (1540) <i>rh</i> Relative Humidity (1538) <i>Pro</i> Process (75) <i>Power</i> Power (73)	Process	Instance 1 Map 1 Map 2 ---- 442	0x68 (104) 1 0x2A (42)	5	4042	uint RWES

** R: Read, W: Write, E: EEPROM, S: User Set

Setup Page

Display	Parameter Name Description	Range	Default	Modbus Relative Address	CIP - Class In- stance Attribute hex (dec)	Pro- fibus Index	Pa- rame- ter ID	Data Type and Ac- cess **
S.Lo S.Lo	Analog Input Scale Low Set the low scale for process inputs. This value, in millivolts, volts or milliamps, will correspond to the Range Low output of this function block.	-100.00 to 100.00	0.0	Instance 1 Map 1 Map 2 388 388	0x68 (104) 1 0xF (15)	6	4015	float RWES
S.hi S.hi	Analog Input Scale High Set the high scale for process inputs. This value, in millivolts, volts or milliamperes, will correspond to the Range High output of this function block.	-100.00 to 100.00	20.0	Instance 1 Map 1 Map 2 390 390	0x68 (104) 1 0x10 (16)	7	4016	float RWES
r.Lo r.Lo	Analog Input Range Low Set the low range for this function block's output.	-1,999.000 to 9,999.000	0.0	Instance 1 Map 1 Map 2 392 392	0x68 (104) 1 0x11 (17)	8	4017	float RWES
r.hi r.hi	Analog Input Range High Set the high range for this function block's output.	-1,999.000 to 9,999.000	9,999	Instance 1 Map 1 Map 2 394 394	0x68 (104) 1 0x12 (18)	9	4018	float RWES
PEE P.EE	Analog Input Process Error Enable Turn the Process Error Low feature on or off.	oFF Off (62) LoLd Low (53)	Off	Instance 1 Map 1 Map 2 418 418	0x68 (104) 1 0x1E (30)	10	4030	uint RWES
PEL P.EL	Analog Input Process Error Low Value If the process value drops below this value, it will trigger an input error.	-100.00 to 100.00	0.0	Instance 1 Map 1 Map 2 420 420	0x68 (104) 1 0x1F (31)	11	4031	float RWES

** R: Read, W: Write, E: EEPROM, S: User Set

Setup Page

Display	Parameter Name Description	Range	Default	Modbus Relative Address	CIP - Class Instance Attribute hex (dec)	Pro- fibus Index	Pa- rame- ter ID	Data Type and Ac- cess **
t.C t.C	Analog Input Thermistor Curve Select a curve to apply to the thermistor input.	A Curve A (1451) b Curve B (1452) c Curve C (1453) cUsE Custom (180)	Curve A	Instance 1 Map 1 Map 2 434 434	0x68 (104) 1 0x26 (38)	- - - -	4038	uint RWES
r.r r.r	Analog Input Resistance Range Set the maximum resistance of the thermistor input.	5 5K (1448) 10 10K (1360) 20 20K (1361) 40 40K (1449)	40K	Instance 1 Map 1 Map 2 432 432	0x68 (104) 1 0x25 (37)	- - - -	4037	uint RWES
F iL FiL	Analog Input Filter Filtering smooths out the process signal to both the display and the input. Increase the time to increase filtering.	0.0 to 60.0 seconds Note: Filter does not apply to the Limit sensor but does apply to all other functions.	0.5	Instance 1 Map 1 Map 2 386 386	0x68 (104) 1 0xE (14)	12	4014	float RWES
i.Er i.Er	Analog Input Input Error Latching Turn input error latching on or off. If latching is on, errors must be manually cleared.	aFF Off (62) aOn On (63)	Off	Instance 1 Map 1 Map 2 414 414	0x68 (104) 1 0x1C (28)	- - - -	4028	uint RWES
dEC dEC	Analog Input Display Precision Set the precision of the displayed value.	0 Whole (105) 0.0 Tenths (94) 0.00 Hundredths (40) 0.000 Thousandths (96)	Whole	Instance 1 Map 1 Map 2 398 398	0x68 (104) 1 0x14 (20)	- - - -	4020	uint RWES
i.CA i.CA	Analog Input Calibration Offset Offset the input reading to compensate for lead wire resistance or other factors that cause the input reading to vary from the actual process value.	-1,999.000 to 9,999.000°F or units -1,110.555 to 5,555.000°C	0.0	Instance 1 Map 1 Map 2 382 382	0x68 (104) 1 0xC (12)	2	4012	float RWES

** R: Read, W: Write, E: EEPROM, S: User Set

Setup Page

Display	Parameter Name Description	Range	Default	Modbus Relative Address	CIP - Class In- stance Attribute hex (dec)	Pro- fibus Index	Pa- rame- ter ID	Data Type and Ac- cess **
<i>Ain</i>	Analog Input Analog Input Value View the process value. Note: Ensure that the Error Status (below) indicates no error (61) when reading this value using a field bus protocol. If an error exists, the last known value prior to the error occurring will be returned.	-1,999.000 to 9,999.000°F or units -1,128.000 to 5,537.000°C	- - - -	Instance 1 Map 1 Map 2 360 360	0x68 (104) 1 1	0	4001	float R
<i>iEr</i>	Analog Input Input Error View the cause of the most recent error.	<i>nonE</i> None (61) <i>OPEn</i> Open (65) <i>Shrt</i> Shorted (127) <i>Err</i> Measurement Error (140) <i>EEAL</i> Bad Calibration Data (139) <i>ErAb</i> Ambient Error (9) <i>Errd</i> RTD Error (141) <i>FRiL</i> Fail (32)	- - - -	Instance 1 Map 1 Map 2 362 442	0x68 (104) 1 2	1	4002	uint R
<div style="text-align: center;"> <p><i>diO</i></p> <p><i>SEt</i></p> <p>Digital Input/Output Menu</p> </div>								
<i>dir</i>	Digital Input/Output (5 to 6) Direction Set this function to operate as an input or output.	<i>oPtE</i> Output (68) <i>in</i> Input Voltage (193) <i>iEon</i> Input Dry Contact (44)	Output	Instance 5 Map 1 Map 2 1000 1120 Offset to next instance (Map 1 & Map 2) equals +30	0x6A (106) 5 to 6 1	82	6001	uint RWES

** R: Read, W: Write, E: EEPROM, S: User Set

Setup Page

Display	Parameter Name Description	Range	Default	Modbus Relative Address	CIP - Class Instance Attribute hex (dec)	Pro-fibus Index	Pa-rame-ter ID	Data Type and Access **
<i>F_n</i> Fn	Digital Output (5 to 6) Function Select what function will drive this output.	<i>oFF</i> Off (62) <i>ALP7</i> Alarm (6)	Off	Instance 5 Map 1 Map 2 1008 1128 Offset to next instance (Map 1 & Map 2) equals +30	0x 6A (106) 5 to 6 5	83	6005	uint RWES
<i>F_i</i> Fi	Digital Output (5 to 6) Output Function Instance Set the instance of the function selected above.	1 to 4 Note: Modbus Map 1 has instances 5 through 8 only	1	Instance 5 Map 1 Map 2 1010 1130 Offset to next instance (Map 1 & Map 2) equals +30	0x6A (106) 5 to 6 6	84	6006	uint RWES
<i>LE_v</i> LEv	Digital Input (5 to 6) Active Level Select which action will be interpreted as a true state.	<i>h_{igh}</i> High (37) <i>Lo_w</i> Low (53)	High	Instance 5 Map 1 Map 2 1320 1560 Offset to next instance (Map 1 & Map 2) equals +20	0x6E (110) 5 to 6 1	137	10001	uint RW
<i>F_n</i> Fn	Digital Input (5 to 6) Action Function Select the function that will be triggered by a true state for Digital Inputs 5 to 6.	<i>nonE</i> None (61) <i>F_{AL}</i> Force Alarm to occur, level triggered (218) <i>R_{oF}</i> Control Loops Off and Alarms to Non-alarm State, level triggered (220) <i>S_{iL}</i> Silence Alarms, edge triggered (108) <i>ALP7</i> Alarm Reset, edge triggered (6) <i>P_LoC</i> Keypad Lockout, level triggered (217) <i>u_Sr_r</i> User Set Restore, edge triggered (227)	None	Instance 5 Map 1 Map 2 1324 1564 Offset to next instance (Map 1 & Map 2) equals +20	0x6E (110) 5 to 6 3	138	10003	uint RWES

** R: Read, W: Write, E: EEPROM, S: User Set

Setup Page

Display	Parameter Name Description	Range	Default	Modbus Relative Address	CIP - Class In- stance Attribute hex (dec)	Pro- fibus Index	Pa- ra-me- ter ID	Data Type and Ac- cess **
<i>F</i> , Fi	Digital Input (5 to 6) Function Instance Select which Digital Input will be triggered by a true state.	0 to 40	0	Instance 5 Map 1 Map 2 1326 1566 Offset to next instance (Map 1 & Map 2) equals +20	0x6E (110) 5 to 6 4	139	10004	uint RWES

L, *L*¹⁷

SEt

Limit Menu

<i>L.Sd</i> L.Sd	Limit Sides Select which side or sides of the process value will be moni- tored.	<i>both</i> Both (13) <i>high</i> High (37) <i>low</i> Low (53)	Both	Instance 1 Map 1 Map 2 688 728	0x70 (112) 1 5	40	12005	uint RWES
<i>L.hy</i> L.hy	Limit Hysteresis Set the hysteresis for the limit function. This determines how far into the safe range the process value must move before the limit can be cleared.	0.001 to 9,999.000°F or units 0.001 to 5,555.000°C	3.0°F or units 2.0°C	Instance 1 Map 1 Map 2 682 722	0x70 (112) 1 2	41	12002	float RWES
<i>SPLh</i> SP.Lh	Limit Maximum Set Point Set the high end of the limit set point range.	-1,999.000 to 9,999.000	9,999.000	Instance 1 Map 1 Map 2 696 736	0x70 (112) 1 9	42	12009	float RWES
<i>SPLL</i> SP.LL	Limit Minimum Set Point Set the low end of the limit set point range.	-1,999.000 to 9,999.000	-1,999.000	Instance 1 Map 1 Map 2 698 738	0x70 (112) 1 0xA (10)	43	12010	float RWES
<i>Lh.S</i> Lh.S	Limit High Limit Set Point Set the high process value that will trigger the limit.	-1,999.000 to 9,999.000°F or units -1,128.000 to 5,537.000°C	0.0°F or units -18.0°C	Instance 1 Map 1 Map 2 686 726	0x70 (112) 1 4	39	12004	float RWES

** R: Read, W: Write, E: EEPROM, S: User Set

Setup Page

Display	Parameter Name Description	Range	Default	Modbus Relative Address	CIP - Class Instance Attribute hex (dec)	Pro-fibus Index	Pa-rame-ter ID	Data Type and Access **
LLS LL.S	Limit Low Limit Set Point Set the low process value that will trigger the limit.	-1,999.000 to 9,999.000°F or units -1,128.000 to 5,537.000°C	0.0°F or units -18.0°C	Instance 1 Map 1 Map 2 684 724	0x70 (112) 1 3	38	12003	float RWES
SFn.A SFn.A	Limit Source Function A Set the source for the limit reset function.	<i>none</i> None (61) <i>di</i> Digital I/O (1142) <i>Fun</i> Function Key (1001)	None	Instance 1 Map 1 Map 2 ----- 748	0x70 (112) 1 0x0F (15)	-----	12015	uint RWES
Si.A Si.A	Limit Source Instance A Set the instance of the function selected above.	1 to 12	1	-----	0x70 (112) 1 0x10 (16)	-----	12016	uint RWES
LCr LCr	Limit Clear Limit Clear limit once limit condition is safe.	<i>CLr</i> Clear (129) <i>Ignr</i> Ignore (204)	-----	Instance 1 Map 1 Map 2 680 720	0x70 (112) 1 1	-----	12014	uint W
LSt L.St	Limit Limit Status Reflects whether or not the limit is in a safe or failed mode.	<i>FAIL</i> Fail (32) <i>SAFE</i> Safe (1667)	-----	Instance 1 Map 1 Map 2 ----- 744	0x70 (112) 1 0x0D (13)	-----	12013	uint R
No Display	Limit Limit State Clear limit once limit condition is cleared.	Off (62) None (61) Limit High (51) Limit Low (52) Error (28)	-----	Instance 1 Map 1 Map 2 690 730	0x70 (112) 1 6	-----	12006	uint R

** R: Read, W: Write, E: EEPROM, S: User Set

Setup Page

Display	Parameter Name Description	Range	Default	Modbus Relative Address	CIP - Class In- stance Attribute hex (dec)	Pro- fibus Index	Pa- rame- ter ID	Data Type and Ac- cess **
<p><i>oLPL</i> <i>SEt</i></p> <h3>Output Menu</h3>								
<i>Fn</i> Fn	Output Digital (1 to 4) Function Select what function will drive this output. Note: Output 2 is always a limit. Use as primary limit connection. Only Output 1. May also be specified as limit.	<i>oFF</i> Off (62) <i>LPL</i> Limit (126) <i>ALPL</i> Alarm (6)	Output 1 - Alarm Output 2 - Limit Output 3 - Off Output 4 - Off	Instance 1 Map 1Map 2 888 1008 Offset to next instance (Map 1 & Map 2) equals +30	0x6A (106) 1 to 4 5	83	6005	uint RWES
<i>F,Fi</i> Fi	Output Digital (1 to 4) Output Function Instance Set the instance of the function selected above.	1 to 4	1	Instance 1 Map 1Map 2 890 1010 Offset to next instance (Map 1 & Map 2) equals +30	0x6A (106) 1 to 4 6	84	6006	uint RWES
<i>oLy</i> o.ty	Output Process (3) Type Select whether the process output will operate in volts or milliamps.	<i>uolt</i> Volts (104) <i>PPA</i> Milliamps (112)	Volts	Instance 3 Map 1Map 2 800 920	0x76 (118) 3 1	95	18001	uint RWES
<i>Fn</i> Fn	Output Process (3) Function Set the type of function that will drive this output.	<i>oFF</i> Off (62) <i>rPLt</i> Retransmit (213) <i>ALPL</i> Alarm (6)	Off	Instance 3 Map 1Map 2 802 922	0x76 (118) 3 2	96	18002	uint RWES
<i>r.Sr</i> r.Sr	Output Process (3) Retransmit Source Select the value that will be retransmitted.	<i>R,Analog Input</i> (142)	Analog Input	Instance 3 Map 1Map 2 804 924	0x76 (118) 3 3	97	18003	uint RWES

** R: Read, W: Write, E: EEPROM, S: User Set

Setup Page

Display	Parameter Name Description	Range	Default	Modbus Relative Address	CIP - Class In- stance Attribute hex (dec)	Pro- fibus Index	Pa- rame- ter ID	Data Type and Ac- cess **
<i>F</i> , Fi	Output Process (3) Function Instance Set the instance of the function selected above.	1 to 4	1	Instance 3 Map 1Map 2 806 926	0x76 (118) 3 4	98	18004	uint RWES
<i>S.L</i> ◻ S.Lo	Output Process (3) Scale Low Set the scale low for process output in electrical units. This value; in volts or milliamps, will corre- spond to range low retransmit output.	-100.0 to 100.0	0.00	Instance 3 Map 1Map 2 816 936	0x76 (118) 3 9	99	18009	float RWES
<i>S.h</i> , S.hi	Output Process (3) Scale High Set the scale high for process output in electrical units. This value; in volts or milliamps, will corre- spond to range high retransmit output.	-100.0 to 100.0	10.00	Instance 3 Map 1Map 2 818 938	0x76 (118) 3 0x0A (10)	100	18010	float RWES
<i>r.L</i> ◻ r.Lo	Output Process (3) Range Low Set the minimum value of the retransmit value range in process units. When the retransmit source is at this value, the retransmit output will be at its Scale Low value.	-1,999.000 to 9,999.000°F or units -1,128.000 to 5,537.000°C	0.0°F or units -18°C	Instance 3 Map 1Map 2 820 940	0x76 (118) 3 0x0B (11)	101	18011	float RWES

** R: Read, W: Write, E: EEPROM, S: User Set

Setup Page

Display	Parameter Name Description	Range	Default	Modbus Relative Address	CIP - Class In- stance Attribute hex (dec)	Pro- fibus Index	Pa- rame- ter ID	Data Type and Ac- cess **
<i>r.h.i</i> r.hi	Output Process (3) Range High Set the maximum value of the retransmit value range in process units. When the retransmit source is at this value, the retransmit output will be at its Scale High value.	-1,999.000 to 9,999.000°F or units -1,128.000 to 5,537.000°C	100.0°F or units 38.0°C	Instance 3 Map 1Map 2 822 942	0x76 (118) 3 0x0C (12)	102	18012	float RWES
<i>a.CA</i> o.CA	Output Process (3) Calibration Offset Set an offset value for a process output.	-1,999.000 to 9,999.000°F or units -1,110.555 to 5,555.000°C	0.0°F or units 0.0°C	Instance 3 Map 1Map 2 812 932	0x76 (118) 3 7	105	18007	float RWES
<p><i>ALP7</i></p> <p><i>SET</i></p> <p>Alarm Menu</p>								
<i>ALY</i> A.ty	Alarm (1 to 4) Type Select whether the alarm trigger is a fixed value or will track the set point.	<i>OFF</i> Off (62) <i>Pr.AL</i> Process Alarm (76)	Off	Instance 1 Map 1Map 2 1508 1908 Offset to next instance (Map 1 +50, Map 2 +60)	0x6D (109) 1 to 4 0xF (15)	20	9015	uint RWES
<i>Sr.A</i> Sr.A	Alarm (1 to 4) Alarm Source Select what will trigger this alarm.	<i>R.I</i> Analog Input (142)	Analog Input	Instance 1 Map 1Map 2 1512 1912 Offset to next instance (Map 1 +50, Map 2 +60)	0x6D (109) 1 to 4 0x11 (17)	21	9017	uint RWES
<p>** R: Read, W: Write, E: EEPROM, S: User Set</p>								

Setup Page

Display	Parameter Name Description	Range	Default	Modbus Relative Address	CIP - Class Instance Attribute hex (dec)	Pro-fibus Index	Pa-rame-ter ID	Data Type and Access **
<i>Rh y</i> A.hy	Alarm (1 to 4) Hysteresis Set the hysteresis for an alarm. This determines how far into the safe region the process value needs to move before the alarm can be cleared.	0.001 to 9,999.000°F or units 0.001 to 5,555.000°C	1.0°F or units 1.0°C	Instance 1 Map 1Map 2 1484 1884 Offset to next instance (Map 1 equals +50, Map 2 +60)	0x6D (109) 1 to 4 3	24	9003	float RWES
<i>RL G</i> A.Lg	Alarm (1 to 4) Logic Select what the output condition will be during the alarm state.	<i>RLC</i> Energize on alarm (17) <i>RLo</i> De-energize on alarm (66)	Close On Alarm	Instance 1 Map 1Map 2 1488 1888 Offset to next instance (Map 1 +50, Map 2 +60)	0x6D (109) 1 to 4 5	25	9005	uint RWES
<i>RS d</i> A.Sd	Alarm (1 to 4) Sides Select which side or sides will trigger this alarm.	<i>both</i> Both (13) <i>high</i> High (37) <i>low</i> Low (53)	Both	Instance 1 Map 1Map 2 1486 1886 Offset to next instance (Map 1 +50, Map 2 +60)	0x6D (109) 1 to 4 4	26	9004	uint RWES
<i>RL o</i> A.Lo	Alarm (1 to 4) Low Set Point Set the process value that will trigger a low alarm.	-1,999.000 to 9,999.000°F or units -1,128.000 to 5,537.000°C	32.0°F or units 0.0°C	Instance 1 Map 1Map 2 1482 1882 Offset to next instance (Map 1 +50, Map 2 +60)	0x6D (109) 1 to 4 2	18	9002	float RWES
<i>Rh i</i> A.hi	Alarm (1 to 4) High Set Point Set the process value that will trigger a high alarm.	-1,999.000 to 9,999.000°F or units -1,128.000 to 5,537.000°C	300.0°F or units 150.0°C	Instance 1 Map 1Map 2 1480 1880 Offset to next instance (Map 1 +50, Map 2 +60)	0x6D (109) 1 to 4 1	19	9001	float RWES

** R: Read, W: Write, E: EEPROM, S: User Set

Setup Page

Display	Parameter Name Description	Range	Default	Modbus Relative Address	CIP - Class Instance Attribute hex (dec)	Pro- fibus Index	Pa- rame- ter ID	Data Type and Ac- cess **
<i>RLA</i> A.LA	Alarm (1 to 4) Latching Turn latching on or off. A latched alarm has to be turned off by the user.	<i>nLAL</i> Non-Latching (60) <i>LAL</i> Latching (49)	Non-Latching	Instance 1 Map 1Map 2 1492 1892 Offset to next instance (Map 1 +50, Map 2 +60)	0x6D (109) 1 to 4 7	27	9007	uint RWES
<i>RbL</i> A.bL	Alarm (1 to 4) Blocking Select when an alarm will be blocked. After startup and/or after the set point changes, the alarm will be blocked until the process value enters the normal range.	<i>oFF</i> Off (62) <i>StR</i> Startup (88) <i>StPt</i> Set Point (85) <i>both</i> Both (13)	Off	Instance 1 Map 1Map 2 1494 1894 Offset to next instance (Map 1 +50, Map 2 +60)	0x6D (109) 1 to 4 8	28	9008	uint RWES
<i>RSi</i> A.Si	Alarm (1 to 4) Silencing Turn silencing on to allow the user to disable this alarm.	<i>oFF</i> Off (62) <i>on</i> On (63)	Off	Instance 1 Map 1Map 2 1490 1890 Offset to next instance (Map 1 equals +50, for Map 2 equals +60)	0x6D (109) 1 to 4 6	29	9006	uint RWES
<i>RdSP</i> A.dSP	Alarm (1 to 4) Display Display an alarm message when an alarm is active.	<i>oFF</i> Off (62) <i>on</i> On (63)	On	Instance 1 Map 1Map 2 1510 1910 Offset to next instance (Map 1 equals +50, for Map 2 equals +60)	0x6D (109) 1 to 4 0x10 (16)	30	9016	uint RWES

** R: Read, W: Write, E: EEPROM, S: User Set

Setup Page

Display	Parameter Name Description	Range	Default	Modbus Relative Address	CIP - Class In- stance Attribute hex (dec)	Pro- fibus Index	Pa- rame- ter ID	Data Type and Ac- cess **
<i>AdL</i> A.dL	Alarm (1 to 4) Delay Time Set the span of time that the alarm will be delayed after the process value exceeds the alarm set point.	0 to 9,999 seconds	0	Instance 1 Map 1Map 2 1520 1920 Offset to next instance (Map 1 equals +50, for Map 2 equals +60)	0x6D (109) 1 to 4 0x15 (21)	31	9021	uint RWES
<i>RELR</i> A.Clr	Alarm (1 to 4) Clear Alarm Write to this register to clear an alarm Note: If an alarm is setup to latch when active <i>RELR</i> will appear on the display.	<i>CLR</i> Clear (0) <i>IGNR</i> Ignore (204)	----	Instance 1 Map 1Map 2 1504 1904 Offset to next instance (Map1 1 equals +50, Map 2 equals +60)	0x6D (109) 1 to 4 0xD (13)	----	9013	uint W
<i>RSIR</i> A.Sir	Alarm (1 to 4) Silence Alarm Write to this register to silence an alarm Note: If an alarm is setup to silence alarm when active <i>RSIR</i> will appear on the display.	<i>SIL</i> Silence (1010)	----	Instance 1 Map 1Map 2 1506 1906 Offset to next instance (Map1 1 equals +50, Map 2 equals +60)	0x6D (109) 1 to 4 0xE (14)	----	9014	uint W
<i>RSE</i> A.St	Alarm (1 to 4) Alarm State Current state of alarm	<i>STR</i> Startup (88) <i>NONE</i> None (61) <i>BLK</i> Blocked (12) <i>ALL</i> Alarm low (8) <i>ALH</i> Alarm high (7) <i>ALE</i> Error (28)	----	Instance 1 Map 1Map 2 1496 1896 Offset to next instance (Map1 1 equals +50, Map 2 equals +60)	0x6D (109) 1 to 4 9	----	9009	uint R

** R: Read, W: Write, E: EEPROM, S: User Set

Setup Page

Display	Parameter Name Description	Range	Default	Modbus Relative Address	CIP - Class In- stance Attribute hex (dec)	Pro- fibus Index	Pa- rame- ter ID	Data Type and Ac- cess **
<p><i>Fun</i></p> <p><i>SET</i></p> <p>Function Key</p>								
<i>LEv</i> LEv	<p>Function Key</p> <p>Active Level</p> <p>The Function Key will always power up in the low state. Pressing the Function Key will toggle the selected action.</p>	<p><i>High</i> High (37)</p> <p><i>Low</i> Low (53)</p>	High	<p>Instance 3</p> <p>Map 1 Map 2</p> <p>1360 1600</p> <p>Instance 4</p> <p>Map 1 Map 2</p> <p>1380 1620</p>	0x6E (110) 3 to 4 1	137	10001	uint RWES
<i>Fn</i> Fn	<p>Function Key</p> <p>Action Function</p> <p>Program the Function Key to trigger an action. Functions respond to a level state change or an edge level change.</p>	<p><i>None</i> None (61)</p> <p><i>User Set</i> User Set Restore, edge triggered (227)</p> <p><i>Keypad</i> Keypad Lockout, level triggered (217)</p> <p><i>Alarm Reset</i> Alarm Reset, edge triggered (6)</p> <p><i>Silence</i> Silence Alarms, edge triggered (108)</p> <p><i>Force Alarm</i> Force Alarm to occur, level triggered (218)</p> <p><i>Limit Reset</i> Limit Reset, edge triggered (82)</p>	None	<p>Instance 3</p> <p>Map 1 Map 2</p> <p>1364 1604</p> <p>Instance 4</p> <p>Map 1 Map 2</p> <p>1384 1624</p>	0x6E (110) 3 to 4 3	138	10003	uint RWES
<i>Fi</i> Fi	<p>Function Key</p> <p>Function Instance</p> <p>Select which instance the Function Key will affect. If only one instance is available, any selection will affect it.</p>	0 to 40	0	<p>Instance 3</p> <p>Map 1 Map 2</p> <p>1366 1606</p> <p>Instance 4</p> <p>Map 1 Map 2</p> <p>1386 1626</p>	0x96 (110) 3 to 4 4	139	10004	----

** R: Read, W: Write, E: EEPROM, S: User Set

Setup Page

Display	Parameter Name Description	Range	Default	Modbus Relative Address	CIP - Class In- stance Attribute hex (dec)	Pro- fibus Index	Pa- rame- ter ID	Data Type and Ac- cess **
9LbL 5Et Global Menu								
C_F C_F	Global Display Units Select which scale to use for temperature.	F °F (30) C °C (15)	°F	Instance 1 Map 1Map 2 1838 2308	0x67 (103) 1 5	110	3005	uint RWES
AC.LF AC.LF	Global AC Line Frequency Set the frequency to the applied ac line power source.	50 50 Hz (3) 60 60 Hz (4)	60 Hz	Instance 1 Map 1Map 2 886 1006	0x6A (106) 1 4	89	1034	uint RWES
C.LEd C.LEd	Global Communications LED Action Turns comms LED on or off for selected comms ports.	Com1 Comm port 1 (1189) Com2 Comm port 2 (1190) both Comm port 1 and 2 (13) off Off (62)	both	Instance 1 Map 1Map 2 1856 2326	0x6A (103) 1 0x0E (14)	----	3014	uint RWES
Zone Zone	Global Zone Turns Zone LED on or off based on selection.	off Off (62) on On (63)	On	Instance 1 Map 1Map 2 ---- 2350	0x6A (103) 1 0x1A (26)	----	3026	uint RWES
Chan Chan	Global Channel Turns Channel LED on or off based on selec- tion.	off Off (62) on On (63)	On	Instance 1 Map 1Map 2 ---- 2352	0x6A (103) 1 0x1B (27)	----	3027	uint RWES
d.PrS d.PrS	Global Display Pairs Defines the number of Display Pairs.	1 to 10	2	Instance 1 Map 1Map 2 ---- 2354	0x6A (103) 1 0x1C (28)	----	3028	uint RWES
d.ti d.ti	Global Display Time Time delay in toggling between Display Pairs.	0 to 60	0	Instance 1 Map 1Map 2 ---- 2356	0x6A (103) 1 0x1D (29)	----	3029	uint RWES

** R: Read, W: Write, E: EEPROM, S: User Set

Setup Page

Display	Parameter Name Description	Range	Default	Modbus Relative Address	CIP - Class Instance Attribute hex (dec)	Pro- fibus Index	Pa- rame- ter ID	Data Type and Ac- cess **
<i>USr.S</i> USr.S	Global Save Settings As Save all of this con- troller's settings to the selected set.	<i>SEt 1</i> User Set 1 (101) <i>SEt 2</i> User Set 2 (102) <i>nonE</i> None (61)	None	Instance 1 Map 1Map 2 26 26	0x(101) 1 0xE (14)	118	1014	uint RWE
<i>USr.r</i> USr.r	Global Restore Settings From Replace all of this controller's settings with another set.	<i>FACTY</i> Factory (31) <i>nonE</i> None (61) <i>SEt 1</i> User Set 1 (101) <i>SEt 2</i> User Set 2 (102)	None	Instance 1 Map 1Map 2 24 24	0x65 (101) 1 0xD (13)	117	1013	uint RWE

CoPn

SEt

Communications Menu

<i>PCoL</i> PCoL	Communications 1 Protocol Set the protocol of this controller to the proto- col that this network is using.	<i>Std</i> Standard Bus (1286) <i>PnMod</i> Modbus RTU (1057)	Modbus	Instance 1 Map 1Map 2 2492 2972	0x96 (150) 1 7	----	17009	uint RWE
---------------------	---	--	--------	---------------------------------------	-------------------------	------	-------	-------------

Standard Bus

<i>Ad.S</i> Ad.S	Communications 1 Standard Bus Ad- dress Set the network ad- dress of this controller. Each device on the network must have a unique address. The Zone Display on the front panel will dis- play this number.	1 to 16	1	Instance 1 Map 1Map 2 2480 2960	0x96 (150) 1 1	----	17001	uint RWE
---------------------	--	---------	---	---------------------------------------	-------------------------	------	-------	-------------

Modbus RTU

<i>Ad.Pn</i> Ad.M	Communications (1 or 2) Modbus Address Set the network ad- dress of this controller. Each device on the network must have a unique address.	1 to 247	1	Instance 1 Map 1Map 2 2482 2962 Instance 2 Map 1Map 2 2500 2980	0x96 (150) 1 to 2 2	----	17007	uint RWE
----------------------	---	----------	---	--	------------------------------	------	-------	-------------

** R: Read, W: Write, E: EEPROM, S: User Set

Setup Page

Display	Parameter Name Description	Range	Default	Modbus Relative Address	CIP - Class In- stance Attribute hex (dec)	Pro- fibus Index	Pa- rame- ter ID	Data Type and Ac- cess **
<i>bAUD</i> bAUd	Communications (1 or 2) Baud Rate Set the speed of this controller's communi- cations to match the speed of the Modbus serial network.	<i>9600</i> 9,600 (188) <i>192</i> 19,200 (189) <i>384</i> 38,400 (190)	9,600	Instance 1 Map 1Map 2 2484 2964 Instance 2 Map 1 Map 2 2504 2984	0x96 (150) 1 to 2 3	----	17002	uint RWE
<i>PAR</i> PAr	Communications (1 or 2) Parity Set the parity of this controller to match the parity of the Modbus serial network.	<i>none</i> None (61) <i>Even</i> Even (191) <i>odd</i> Odd (192)	None	Instance 1 Map 1Map 2 2486 2966 Instance 2 Map 1 Map 2 2506 2986	0x96 (150) 1 to 2 4	----	17003	uint RWE
<i>C_F</i> C_F	Communications (1 or 2) Display Units Select whether this communications chan- nel will display in Cel- sius or Fahrenheit.	<i>F</i> Fahrenheit (30) <i>C</i> Celsius (15) Note: Applies to Modbus and Ethernet.	F	Instance 1 Map 1Map 2 2490 2970	0x96 (150) 1 6	----	17050	uint RWE
<i>M.hL</i> M.hL	Communications (1 or 2) Modbus Word Order Select the word or- der of the two 16-bit words in the float- ing-point values.	<i>L o h i</i> Low-High (1331) <i>h i L o</i> High-Low (1330)	Low-High	Instance 1 Map 1Map 2 2488 2968 Instance 2 Map 1 Map 2 2508 2988	0x96 (150) 1 to 2 5	----	17043	uint RWE
<i>MAP</i> Map	Communications (1 or 2) Data Map If set to 1 the control will use PM legacy mapping. If set to 2 the control will use new mapping to ac- commodate new func- tions.	1 to 2	1 if 9th digit of part number is a D or 1 other- wise, 2.	----	----	----	17059	uint RWE

** R: Read, W: Write, E: EEPROM, S: User Set

Setup Page

Display	Parameter Name Description	Range	Default	Modbus Relative Address	CIP - Class Instance Attribute hex (dec)	Pro- fibus Index	Pa- rame- ter ID	Data Type and Ac- cess **
nUS nVS	Communications (1 or 2) Non-Volatile Save If set to Yes all values written to the control will be saved in EE- PROM. The EEPROM allows for approx- imately one million writes.	YES Yes (106) no No (59)	Yes	Instance 1 Map 1Map 2 2494 2974	0x96 (150) 1 8	198	17051	uint RWE
no dis- play	Communications (1 or 2) Tick Value increases at 1mS rate.	0 to 4,294,967,295	----	Instance 1 Map 1Map 2 5020 8950	----	----	16006	un- signed 32-bit RWE

DeviceNet

Rd.d Ad.d	Communications (2) DeviceNet™ Node Address Set the DeviceNet™ address for this gate- way.	0 to 63	63	----	----	----	17052	----
bAUd bAUd	Communications (2) DeviceNet™ Baud Rate Set the DeviceNet speed for this gate- way's communications to match the speed of the serial network.	125 125 kb (1351) 250 250 kb (1352) 500 500 kb (1353)	125	----	----	----	17053	----
FCE FC.E	Communications (2) DeviceNet™ Quick Connect Enable Allows for immediate communication with the scanner upon power up.	no No (59) YES Yes (106)	No	----	----	----	17054	----
Ra.nb Ao.nb	Communications (2) CIP Implicit Assem- bly Output Member Quantity	1 to 20	20	----	----	----	24009	----
Ri.nb Ai.nb	Communications (2) CIP Implicit Assembly Input Member Quan- tity	1 to 20	20	----	----	----	24010	----

** R: Read, W: Write, E: EEPROM, S: User Set

Setup Page

Display	Parameter Name Description	Range	Default	Modbus Relative Address	CIP - Class Instance Attribute hex (dec)	Profibus Index	Parameter ID	Data Type and Access **
<i>C_F</i> C_F	Communications (2) Display Units Select which scale to use for temperature passed over communications port 2.	<i>F</i> °F (30) <i>C</i> °C (15)	°F	Instance 2 Map 1Map 2 ----- 2990	0x96 (150) 2 6	199	17050	uint RWE
<i>nUS</i> n.U.S	Communications (2) Non-volatile Save If set to Yes all values written to the control will be saved in EEPROM. The EEPROM allows for approximately one million writes.	<i>YES</i> Yes (106) <i>no</i> No (59)	No	Instance 2 Map 1Map 2 2514 2994	96 (150) 2 8	198	17051	uint RWE
Profibus DP								
<i>PAdd</i> P.Add	Communications (2) Profibus Node Address Set the Profibus address for this control.	0 to 126	126	-----	-----	-----	17060	-----
<i>ALoc</i> A.Loc	Communications (2) Profibus Address Lock When set to yes will not allow address to be changed using software. Can be changed from front panel.	<i>no</i> No (59) <i>YES</i> Yes (106)	No	-----	-----	-----	17061	-----
<i>Stat</i> Stat	Communications Profibus DP Status Current Profibus status.	<i>Ready</i> Ready (1662) <i>Run</i> Running (149)	-----	-----	-----	-----	17062	uint R
<i>C_F</i> C_F	Communications (2) Display Units Select which scale to use for temperature passed over communications port 2.	<i>F</i> °F (30) <i>C</i> °C (15)	°F	Instance 2 Map 1Map 2 ----- 2990	0x96 (150) 2 6	199	17050	uint RWE
** R: Read, W: Write, E: EEPROM, S: User Set								

Setup Page

Display	Parameter Name Description	Range	Default	Modbus Relative Address	CIP - Class Instance Attribute hex (dec)	Pro- fibus Index	Pa- rame- ter ID	Data Type and Ac- cess **
nUS nU.S	Communications (2) Non-volatile Save If set to Yes all values written to the control will be saved in EEPROM. The EEPROM allows for approximately one million writes.	YES Yes (106) no No (59)	No	Instance 2 Map 1Map 2 2514 2994	96 (150) 2 8	198	17051	uint RWE

Modbus TCP or EtherNet/IP

M.hL	Communications (2) Modbus Word Order Select the word order of the two 16-bit words in the floating-point values.	LoHi Low-High (1331) HiLo High-Low (1330)	Low-High	Instance 1 Map 1Map 2 2488 2968 Instance 2 Map 1Map 2 2508 2988	0x96 (150) 1 to 2 5	----	17043	uint RWE
i.PM	Communications (2) IP Address Mode Select DHCP to let a DHCP server assign an address to this module.	dHCP DHCP (1281) FAdd Fixed Address (1284)	DHCP	----	----	----	17012	----

Note:

When changing IP address, the control power must be cycled for the new address to take effect.

ip.F1	Communications (2) IP Fixed Address Part 1 Set the IP address of this module. Each device on the network must have a unique address.	0 to 255	169	----	----	----	17014	----
ip.F2	Communications (2) IP Fixed Address Part 2 Set the IP address of this module. Each device on the network must have a unique address.	0 to 255	254	----	----	----	17015	----

** R: Read, W: Write, E: EEPROM, S: User Set

Setup Page

Display	Parameter Name Description	Range	Default	Modbus Relative Address	CIP - Class In- stance Attribute hex (dec)	Pro- fibus Index	Pa- rame- ter ID	Data Type and Ac- cess **
<i>.P.F3</i> ip.F3	Communications (2) IP Fixed Address Part 3 Set the IP address of this module. Each device on the network must have a unique address.	0 to 255	1	----	----	----	17016	----
<i>.P.F4</i> ip.F4	Communications (2) IP Fixed Address Part 4 Set the IP address of this module. Each device on the network must have a unique address.	0 to 255	1	----	----	----	17017	----
<i>.P.S1</i> ip.S1	Communications (2) IP Fixed Subnet Part 1 Set the IP subnet mask for this module.	0 to 255	255	----	----	----	17020	----
<i>.P.S2</i> ip.S2	Communications (2) IP Fixed Subnet Part 2 Set the IP subnet mask for this module.	0 to 255	255	----	----	----	17021	----
<i>.P.S3</i> ip.S3	Communications (2) IP Fixed Subnet Part 3 Set the IP subnet mask for this module.	0 to 255	0	----	----	----	17022	----
<i>.P.S4</i> ip.S4	Communications (2) IP Fixed Subnet Part 4 Set the IP subnet mask for this module.	0 to 255	0	----	----	----	17023	----

** R: Read, W: Write, E: EEPROM, S: User Set

Setup Page

Display	Parameter Name Description	Range	Default	Modbus Relative Address	CIP - Class In- stance Attribute hex (dec)	Pro- fibus Index	Pa- rame- ter ID	Data Type and Ac- cess **
<i>.P.91</i> ip.g1	Communications (2) Fixed IP Gateway Part 1 Used for the purpose of sending and receiv- ing messages from another network.	0 to 255	0	----	----	----	17026	----
<i>.P.92</i> ip.g2	Communications (2) Fixed IP Gateway Part 2 Used for the purpose of sending and receiv- ing messages from another network.	0 to 255	0	----	----	----	17027	----
<i>.P.93</i> ip.g3	Communications (2) Fixed IP Gateway Part 3 Used for the purpose of sending and receiv- ing messages from another network.	0 to 255	0	----	----	----	17028	----
<i>.P.94</i> ip.g4	Communications (2) Fixed IP Gateway Part 4 Used for the purpose of sending and receiv- ing messages from another network.	0 to 255	0	----	----	----	17029	----
<i>P.7b.E</i> Mb.E	Communications (2) Modbus TCP Enable Activate Modbus TCP.	<i>YES</i> Yes (106) <i>no</i> No (59)	Yes	----	----	----	17041	----
<i>E .P.E</i> EiP.E	Communications (2) EtherNet/IP™ Enable Activate Ethernet/IP™.	<i>YES</i> Yes (106) <i>no</i> No (59)	Yes	----	----	----	17042	----
<i>P.a.n.b</i> Ao.nb	Communications (2) EtherNet/IP™ Output Assembly When using EtherNet/ IP set the CIP Implic- it Assembly Output Member Quantity	1 to 40	40	----	----	----	24009	----

** R: Read, W: Write, E: EEPROM, S: User Set

Setup Page

Display	Parameter Name Description	Range	Default	Modbus Relative Address	CIP - Class Instance Attribute hex (dec)	Pro-fibus Index	Pa-rame-ter ID	Data Type and Access **
<i>Ai.nb</i> Ai.nb	Communications (2) EtherNet/IP™ Input Assembly When using EtherNet/IP set the CIP Implicit Assembly Input Member Quantity	1 to 40	40	----	----	----	24010	----
<i>C_F</i> C_F	Communications (2) Display Units Select which scale to use for temperature passed over communications port 2.	<i>F</i> °F (30) <i>C</i> °C (15)	°F	Instance 2 Map 1Map 2 ---- 2990	0x96 (150) 2 6	199	17050	uint RWE
<i>nVS</i> nVS	Communications (2) Non-volatile Save If set to Yes all values written to the control will be saved in EEPROM. The EEPROM allows for approximately one million writes.	<i>YES</i> Yes (106) <i>no</i> No (59)	No	Instance 2 Map 1Map 2 2514 2994	96 (150) 2 8	198	17051	uint RWE

** R: Read, W: Write, E: EEPROM, S: User Set

7

Chapter 7: Factory Page

Navigating the Factory Page

To navigate to the Factory Page follow the steps below:

1. From the Home Page, press and hold both the Advance and Reset keys for six seconds.
2. Press the Up or Down key ▲▼ to view available menus.
3. Press the Advance Key to enter the menu of choice.
4. If a sub-menu exists (more than one instance), press the Up or Down key ▲▼ to select and then press the Advance Key to enter.
5. Press the Up or Down key ▲▼ to move through available menu prompts.
6. Press the Reset Key to move backwards through the levels: parameter to sub-menu, sub-menu to menu, menu to Home Page.
7. Press and hold the Reset Key for two seconds to return to the Home Page.

On the following pages, top level menus are identified with a yellow background color.

Note:

Some of these menus and parameters may not appear, depending on the controller's options. See model number information in the Appendix for more information. If there is only one instance of a menu, no sub-menus will appear.

Note:

Some of the listed parameters may not be visible. Parameter visibility is dependent upon controller part number.

CUSE		FCEY	Diagnostics Menu
FCEY	Custom Setup Menu	Pn	Part Number
I		rEv	Software Revision
CUSE	Custom Setup (1 to 20)	SbLd	Software Build Number
PAR	Parameter	Sn	Serial Number
id	Instance ID	dATE	Date of Manufacture
LoC		iPAC	IP Actual Address Mode
FCEY	Security Setting Menu	iPA1	IP Actual Address Part 1
LoCo	Operations Page	iPA2	IP Actual Address Part 2
PASE	Password Enabled	iPA3	IP Actual Address Part 3
rLoC	Read Lock	iPA4	IP Actual Address Part 4
SLoC	Write Security		
LoCL	Locked Access Level	CAL	
roLL	Rolling Password	FCEY	Calibration Menu
PASu	User Password	I	
PASa	Administrator Password	CAL	Calibration (3)
ULoC		rT_u	Electrical Measurement
FCEY	Security Setting Menu	EL_{io}	Electrical Input Offset
CoDE	Public Key	EL_{is}	Electrical Input Slope
PASS	Password	EL_{oo}	Electrical Output Offset
d_iAG		EL_{o5}	Electrical Output Slope

Factory Page

Display	Parameter Name Description	Range	Default	Modbus Relative Address	CIP Class Instance Attribute hex (dec)	Pro-fibus In-dex	Parameter ID	Data Type and Access **
<div style="display: flex; justify-content: space-between;"> CUST FACTY </div> <p>Custom</p>								
PRR Par	<p>Custom Parameter 1 to 20</p> <p>Select the parameters that will appear in the Home Page.</p> <p>The Parameter 1 value will appear in the upper display of the Home Page. It cannot be changed with the Up and Down Keys in the Home Page.</p> <p>The Parameter 2 value will appear in the lower display in the Home Page. It can be changed with the Up and Down Keys, if the parameter is a writable one.</p> <p>Scroll through the other Home Page parameters with the Advance Key.</p> <p>Note: Display Pairs affect the pairing of custom parameters on the Home page. For more information on Display Pairs see the section in this guide entitled "Modifying the Display Pairs".</p>	none None LLS Low Limit Set Point LhS High Limit Set Point LhY Limit Hysteresis LSt Limit Status Pro Process .CA Calibration Offset C_F Display Units USrr Replace Settings From ALo Low Set Point Ah, High Set Point AhY Hysteresis CUST Custom Menu	See: Home Page	----	----	-- --	14005	uint RWES

** R: Read, W: Write, E: EEPROM, S: User Set

Factory Page

Display	Parameter Name Description	Range	Default	Modbus Relative Address	CIP Class Instance Attribute hex (dec)	Pro-fibus Index	Parameter ID	Data Type and Access **
<i>iid</i> iid	Custom (1 to 20) Instance ID Select which instance of the parameter will be selected.	1 to 4		----	----	-- --	14003	uint RWES

LoC

FLCY

Lock Menu

<i>LoCo</i> LoC.o	Security Setting Operations Page Change the security level of the Operations Page.	1 to 3	2	Instance 1 Map 1 Map 2 1832 2302	0x67 (103) 1 2	-- --	3002	uint RWE
<i>PRSE</i> LoC.P	Security Setting Password Enable Set to On to require a password for menu changes.	<i>oFF</i> Off <i>oN</i> On	Off	----	----	-- --	3009	uint RWE
<i>rLoC</i> rLoC	Security Setting Read Lock Set the read security clearance level. The user can access the selected level and all lower levels. If the Set Lockout Security level is higher than the Read Lockout Security, the Read Lockout Security level takes priority.	1 to 5	5	Instance 1 Map 1 Map 2 1848 2318	0x67 (103) 1 0x0A (10)	-- --	3010	uint RWE

** R: Read, W: Write, E: EEPROM, S: User Set

Factory Page

Display	Parameter Name Description	Range	Default	Modbus Relative Ad- dress	CIP Class In- stance Attri- bute hex (dec)	Pro- fibus In- dex	Param- eter ID	Data Type and Ac- cess **
<i>SLoC</i> SLoC	Security Setting Write Security Set the write se- curity clearance level. The user can access the selected level and all lower levels. If the Set Lockout Security level is higher than the Read Lockout Security, the Read Lockout Security level takes priority.	0 to 5	5	Instance 1 Map 1 Map 2 1844 2314	0x67 (103) 1 0x0B (11)	-- --	3011	uint RWE
<i>LoCL</i> LoC.L	Security Setting Locked Access Level Determines user level menu visi- bility when Pass- word Enable is set to on. See Features section under Password Security.	1 to 5	5	----	----	-- --	3016	uint RWE
<i>roLL</i> roLL	Security Setting Rolling Pass- word When power is cycled a new Public Key will be displayed and User Password changes.	<i>oFF</i> Off <i>on</i> On	Off	----	----	-- --	3019	uint RWE
<i>PAS.u</i> PAS.u	Security Setting User Password Used to acquire access to menus made available through the Locked Access Level setting.	10 to 999	63	----	----	-- --	3017	uint RWE

** R: Read, W: Write, E: EEPROM, S: User Set

Factory Page

Display	Parameter Name Description	Range	Default	Modbus Relative Address	CIP Class Instance Attribute hex (dec)	Pro-fibus Index	Parameter ID	Data Type and Access **
<i>PAS.A</i> PAS.A	Security Setting Administrator Password Used to acquire full access to all menus including disabling or changing passwords.	10 to 999	156	----	----	-- --	3018	uint RWE
<i>ULoE</i> <i>FEEY</i> Unlock Menu								
<i>LoDE</i> CodE	Security Setting Public Key If Rolling Password turned on, generates a random number when power is cycled. If Rolling Password is off fixed number will be displayed. The key can be used to gain access when password is not known.	Customer Specific	0	----	----	-- --	3020	uint R
<i>PASS</i> PASS	Security Setting Password Enter the User or Administrator password to gain access. After valid password is supplied exit this menu and re-enter the Security Menu via the Factory Page.	-1999 to 9999	0	----	----	-- --	3022	int RW
** R: Read, W: Write, E: EEPROM, S: User Set								

Factory Page

Display	Parameter Name Description	Range	Default	Modbus Relative Address	CIP Class Instance Attribute hex (dec)	Pro-fibus In-dex	Param-eter ID	Data Type and Access **
<div style="color: red; font-weight: bold; margin-bottom: 5px;">d ,R9</div> <div style="color: green; font-weight: bold; margin-bottom: 5px;">FCEY</div> <div style="font-weight: bold; margin-bottom: 5px;">Diagnostics Menu</div>								
<i>Pn</i> Pn	Diagnostics Part Number Display this controller's part number.	15 characters	----	----	0x65 (101) 1 9	115	1009	string R
<i>rEu</i> rEu	Diagnostics Software Revision Display this controller's firmware revision number.	1 to 10	----	Instance 1 Map 1 Map 2 4 4	0x65 (101) 1 3	116	1003	string R
<i>SbLd</i> S.bLd	Diagnostics Software Build Number Display the firmware build number.	0 to 2,147,483,647	----	Instance 1 Map 1 Map 2 8 8	0x65 (101) 1 5	-- --	1005	dint R
<i>Sn</i> Sn	Diagnostics Serial Number Display the serial number.	0 to 2,147,483,647	----	Instance 1 Map 1 Map 2 12 12	0x65 (101) 1 0x20 (32)	-- --	1032	string R
<i>dAtE</i> dAtE	Diagnostics Date of Manufacture Display the date code (YYWW). Where YY = year and WW= week.	0 to 2,147,483,647	----	Instance 1 Map 1 Map 2 14 14	0x65 (101) 1 8	-- --	1008	dint R
No Display	Diagnostics Hardware ID Display the Hardware ID.	0 to 2,147,483,647	----	Instance 1 Map 1 Map 2 0 0	0x65 (101) 1 1	-- --	1001	dint R
No Display	Diagnostics Firmware ID Display the Firmware ID.	0 to 2,147,483,647	----	Instance 1 Map 1 Map 2 2 2	0x65 (101) 1 2	-- --	1002	dint R
<i>iPAC</i> iP.AC	Diagnostics IP Address Mode Actual address mode (DHCP or Fixed).	<i>dhCP</i> DHCP (1281) <i>FAdd</i> Fixed Address (1284)	DHCP	----	----	-- --	17013	----

** R: Read, W: Write, E: EEPROM, S: User Set

Factory Page

Display	Parameter Name Description	Range	Default	Modbus Relative Address	CIP Class Instance Attribute hex (dec)	Pro-fibus Index	Parameter ID	Data Type and Access **
.PR1 ip.A1	<p>Diagnostics IP Actual Address Part 1 Actual IP address of this module.</p> <p>Note: Although it appears as if this can be changed here this is a read only parameter. Go to Setup Page and then the Com Menu to change.</p>	0 to 255	----	----	----	-- --	17014	R
.PR2 ip.A2	<p>Diagnostics IP Actual Address Part 2 Actual IP address of this module.</p> <p>Note: Although it appears as if this can be changed here this is a read only parameter. Go to Setup Page and then the Com Menu to change.</p>	0 to 255	----	----	----	-- --	17015	R
.PR3 ip.A3	<p>Diagnostics IP Actual Address Part 3 Actual IP address of this module.</p> <p>Note: Although it appears as if this can be changed here this is a read only parameter. Go to Setup Page and then the Com Menu to change.</p>	0 to 255	----	----	----	-- --	17016	R

** R: Read, W: Write, E: EEPROM, S: User Set

Factory Page

Display	Parameter Name Description	Range	Default	Modbus Relative Address	CIP Class Instance Attribute hex (dec)	Pro-fibus In-dex	Param-eter ID	Data Type and Access **
PR4 ip.A4	Diagnostics IP Actual Address Part 4 Actual IP address of this module. Note: Although it appears as if this can be changed here, this is a read only parameter. Go to Setup Page and then the Com Menu to change.	0 to 255	----	----	----	-- --	17017	R

CAL
FCTY

Calibration Menu

EV Mv	Calibration Electrical Measurement Read the raw electrical value for this input in the units corresponding to the Sensor Type (Setup Page, Analog Input Menu) setting.	-3.4e38 to 3.4e38	----	Instance 1 Map 1Map 2 400 400	0x68 (104) 1 0x15 (21)	-- --	4021	float R
EL 10 ELi.o	Calibration Electrical Input Offset Change this value to calibrate the low end of the input range.	-1,999.000 to 9,999.000	0.0	Instance 1 Map 1Map 2 378 378	0x68 (104) 1 0x0A (10)	-- --	4010	float RWES
EL 15 ELi.S	Calibration Electrical Input Slope Adjust this value to calibrate the slope of the input value.	-1,999.000 to 9,999.000	1.0	Instance 1 Map 1Map 2 380 380	0x68 (104) 1 0xB (11)	-- --	4011	float RWES

** R: Read, W: Write, E: EEPROM, S: User Set

Factory Page

Display	Parameter Name Description	Range	Default	Modbus Relative Address	CIP Class Instance Attribute hex (dec)	Pro-fibus Index	Parameter ID	Data Type and Access **
<i>ELo.o</i> ELo.o	Calibration (3) Electrical Output Offset Change this value to calibrate the low end of the output range.	-1,999.000 to 9,999.000	0.0	Instance 3 Map 1Map 2 808 928	0x76 (118) 3 5	-- --	18005	float RWES
<i>ELoS</i> ELoS	Calibration (3) Electrical Output Slope Adjust this value to calibrate the slope of the output value.	-1,999.000 to 9,999.000	1.0	Instance 3 Map 1Map 2 810 930	0x76 (118) 3 6	-- --	18006	float RWES
<i>Pn</i> Pn	Calibration (1 to 2) Part Number Displays current setting for control model number.	<i>FCTy</i> Factory <i>USEr</i> User	----	----	----	-- --	----	uint R
<i>CodE</i> CodE	Calibration (1 to 3) Public Key Changes the control to User or back to original model number as shown on the side of the control.	<i>250 1</i> User Settings <i>606</i> Factory model number	4999	----	----	--- -	----	uint RWES

8

Chapter 8: Features

Changing PM Model Number to PM Express

PM firmware allows the user to switch between a PM control to a PM Express. Switching to a PM Express eliminates the complexity of the PM control by allowing the user to operate with a simplified menu structure.

Note:

When switching from a Full menu control to an Express version, optional PM hardware (even though installed) and firmware features not available in a PM Express will no longer work. To see exactly what is impacted by this change, compare the chart below to the ordering information page in this document.



PM LEGACY Limit Model Configuration Information

① ②	③	④	⑤	⑥ ⑦	⑧	⑨	⑩ ⑪	⑫	⑬ ⑭
PM	Package Size	Primary Functions	Power Supply, Digital I/O	Output 1 and 2 Hardware Options	Comm. Options	Future Option	Output 3 and 4 Hardware Options	Model Selection	Custom Options
						A			
③ Package Size			⑩ ⑪ Output 3 and 4 Hardware Options						
3 = 1/32 DIN (coming soon)			Output 3			Output 4			
6 = 1/16 DIN									
④ Primary Functions									
L = Limit controller with universal input									
M = Limit controller with thermistor input									
⑤ Power Supply, Digital Inputs/Outputs (I/O)									
1 = 100 to 240VAC									
2 = 100 to 240VAC plus 2 digital I/O points (Not available on Express version)									
3 = 20 to 28VAC or 12 to 40VDC									
4 = 20 to 28VAC or 12 to 40VDC, plus 2 digital I/O points (Not available on Express version)									
⑥ ⑦ Output 1 and 2 Hardware Options									
			Output 1			Output 2			
AJ = None			Mechanical relay 5A, Form A						
CJ = Switched dc/open collector			Mechanical relay 5A, Form A						
EJ = Mechanical relay 5A, Form C			Mechanical relay 5A, Form A						
⑧ Communication Options									
Standard bus always included									
A = None									
B = Bluetooth®									
E = EIA-485 Modbus® RTU and Bluetooth® (Not available on Express version)									
F = Modbus® RTU 232/485 and Bluetooth® (Not available on PM3 or Express version)									
G = EtherNet/IP™/Modbus® TCP and Bluetooth® (Not available on PM3 or Express version)									
H = DeviceNet™ and Bluetooth® (Not available on PM3 or Express version)									
J = PROFIBUS DP and Bluetooth® (Not available on PM3 or Express version)									
1 = EIA-485 Modbus® RTU (Not available on Express version)									
2 = EIA-232/485 Modbus® RTU (Not available on PM3 or Express version)									
3 = EtherNet/IP™/Modbus® TCP (Not available on PM3 or Express version)									
5 = DeviceNet™ (Not available on PM3 or Express version)									
6 = PROFIBUS DP (Not available on PM3 or Express version)									
Note: Bluetooth® not available in all countries, contact factory.									
						⑫ Model Selection			
						G = PM LEGACY Version (Output 1 and 2 always isolated)			
						H = PM LEGACY EXPRESS Version (Available in PM3 or PM6) (Output 1 and 2 always isolated)			
						⑬ ⑭ Custom Options			
						WP = Watlow logo face plate			
						WN = No logo/no name face plate			
						AG = Conformal coating			

Watlow® and EZ-ZONE® are registered trademarks of Watlow Electric Manufacturing Company.
SMOOTH-TOUCH™ and EZ-LINK™ are trademarks of Watlow Electric Manufacturing Company.
UL® and cUL® are registered trademarks of Underwriter's Laboratories, Inc.
i-Phone® is a registered trademark of Apple Corporation.
Android™ is a trademark of Google LLC.

Powered by Possibility



To be automatically connected to the nearest North American Technical Sales Office:
1-800-WATLOW2 • www.watlow.com

International Technical Sales Offices:

Austria	+43 6244 20129 0	India	+91 40 6661 2700	Mexico	+52 442 256 2200
China	+86 21 3532 8532	Italy	+39 02 458 8841	Singapore	+65 6773 9488
France	+33 1 41 32 79 70	Japan	+81 3 3518 6630	Spain	+34 91 675 1292
Germany	+49 7253 9400 0	Korea	+82 2 2169 2600	Taiwan	+886 7 288 5168
				UK	+44 115 964 0777

©2020 Watlow Electric Manufacturing Company all rights reserved.

WIN-LEG-0720

How to Change the Controller Model Number

1. Enter Factory Page **FCLY**, Calibration Menu **CAL** via front panel by pressing the Reset Key and the Advance Key together or using PM LEGACY™ Limit Configurator software.
2. Once there, use the Advance Key to navigate to the Part Number **Pn** prompt. The top display will show factory **FCLY** indicating the factory model number as shown on the decal located on the side of the control is currently in effect.
3. Push the Advance Key, Public Key **Code** prompt will be displayed and the number **4999** in the top display.
4. Using the up or down Arrow Keys enter **2501** and push the Advance Key to execute the change. The controller will reboot and the new controller model number is in effect. All previous settings are lost and the controller must be reprogrammed for the application. Be sure to label the controller with the new model number for future reference.

Note:

As noted above, when switching from a PM Standard to a PM Express version, optional hardware (even though installed) may no longer work. Also, all settings will be defaulted to the selected model when switched.

Note:

After switching the model number to a PM Express this document will no longer apply to the control. Click on the link that follows to acquire the latest version of the PM LEGACY™ Limit User's Guide. <http://www.watlow.com/en/Resources-And-Support/Technical-Library/User-Manuals>

Once there, simply enter express in the "Keyword" field to find the appropriate document.

How to Restore Original PM Factory Settings and Model Number

1. Enter Factory Page **FCLY**, Calibration Menu **CAL** via front panel by pressing the Reset Key and the Advance Key together or using PM LEGACY™ Limit Configurator software.
2. Once there, use the Advance Key to navigate to the Part Number **Pn** prompt. The upper display will show user **USER** indicating the user's selected model number is currently in effect.
3. Push the Advance Key where the Public Key **Code** prompt will appear in the lower display and the number **4999** in the upper display.
4. Using the up or down arrow keys **▲▼** enter **505** and push the Advance Key to execute the change. The controller will reboot and the new controller model number is in effect. All previous settings are lost and the controller must be reprogrammed for the application. Be sure to label the controller with the new model number for future reference.

Note:

When switching from a PM Express back to the original model number all original optional hardware will again be enabled for use. Also, when executing this step the control will be factory defaulted back to the original model number (as shown on the side of the control) at zone address 1. This User's Guide would once again apply to this control.

Saving and Restoring Settings

Recording setup and operations parameter settings for future reference is very important. If you unintentionally change these, you will need to program the correct settings back into the controller to return the equipment to operational condition.

After you program the controller and verify proper operation, select Save Settings As **U5r.5** (Setup Page, Global Menu) to save the settings into either of two files (**5Ee1** or **5Ee2**) in the control memory.

Note:

Saving the settings overwrites any previously saved collection of settings. Be sure to document all the controller settings.

If the settings in the controller are altered a user can return the controller to one of three settings. If previously saved, **5Ee1** or **5Ee2** can be restored as well as the factory **FcTy** settings. Navigate to the Setup Page, Global Menu to find the Restore **U5r.r** prompt. A digital input or the Function Key can also be configured to restore parameters.

Note:

When restoring factory defaults, I/O assemblies for Modbus, DeviceNet, Profibus and Ethernet along with the zone address will be overwritten when restoring factory defaults.

Programming the Home Page

Watlow's patented user-defined menu system improves operational efficiency. The user-defined Home Page provides you with a shortcut to monitor or change the parameter values that you use most often.

You can create your own Home Page with as many as 20 of the active parameters. When a parameter normally located in the Setup Page or Operations Page is placed in the Home Page, it is accessible through both. If you change a parameter in the Home Page, it is automatically changed in its original page. If you change a parameter in its original page it is automatically changed in the Home Page.

The default parameters will automatically appear in the Home Page.

Change the list of parameters in the Home Page from the Custom Menu **CUSL** (Factory Page)

Inputs

Calibration Offset

Calibration offset allows a device to compensate for an inaccurate sensor, lead resistance or other factors that affect the input value. A positive offset increases the input value, and a negative offset decreases the input value. The input offset value can be viewed or changed with Calibration Offset **.CR** (Operations Page, Analog Input Menu).

Calibration

Before performing any calibration procedure, verify that the displayed readings are not within published specifications by inputting a known value from a precision source to the analog input. Next, subtract the displayed value with the known value and compare this difference to the published accuracy range specification for that type of input.

Use of the Calibration Offset ΔR parameter found in the Operations Page ΔPER , Analog Input Menu R , shifts the readings across the entire displayed range by the offset value. Use this parameter to compensate for sensor error or sensor placement error. Typically this value is set to zero.

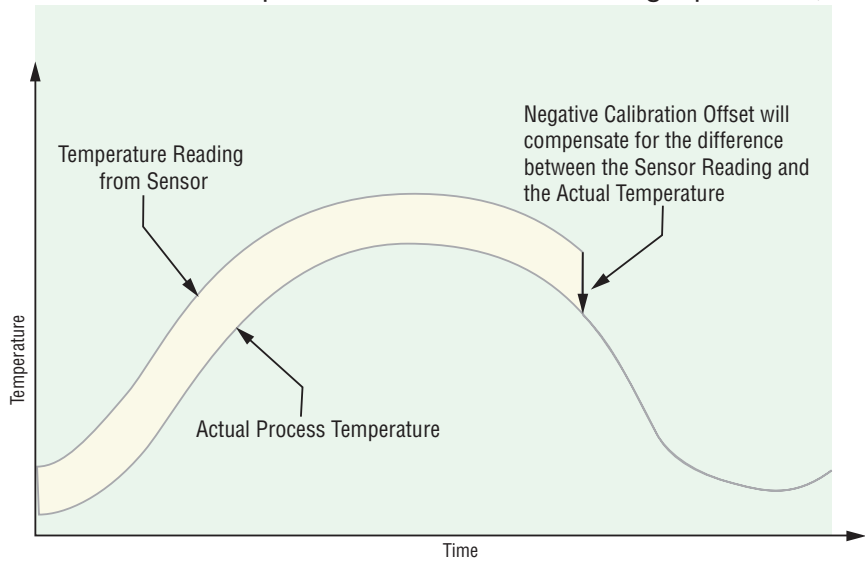

Equipment required while performing calibration:

Obtain a precision source for millivolts, volts, milliamperes or resistance depending on the sensor type to be calibrated. Use copper wire only to connect the precision source to the controller's input. Keep leads between the precision source and controller as short as possible to minimize error. In addition, a precision volt/ohm meter capable of reading values to 4 decimal places or better is recommended. Prior to calibration, connect this volt/ohm meter to the precision source to verify accuracy. Actual input values do NOT have to be exactly the recommended values, but it IS critical that the actual value of the signal connected to the controller be accurately known to at least four digits.

Calibration of Analog Inputs:

To calibrate an analog input, you will need to provide a source of two electrical signals or resistance values near the extremes of the range that the application is likely to utilize. See recommended values below:

Sensor Type	Precision Source Low	Precision Source High
thermocouple	0.000 mV	50.000 mV
millivolts	0.000 mV	50.000 mV
volts	0.000V	10.000V
milliamps	0.000 mA	20.000 mA
100 Ω RTD	50.00 Ω	350.0 Ω
1,000 Ω RTD	500.0 Ω	3,500 Ω
thermistor 5 k Ω	50.00	5,000
thermistor 10 k Ω	150.0	10,000
thermistor 20 k Ω	1,800	20,000
thermistor 40 k Ω	1,700	40,000
potentiometer	0.000	1,200

Note: The user may only calibrate one sensor type. If the calibrator interferes with open thermocouple detection, set Sensor Type SEN in Setup Page SEt , Analog Input Menu A , to millivolt mV instead of Thermocouple TC to avoid interference between the calibrator and open thermocouple detect circuit for the duration of the calibration process. Be sure to set sensor type back to the thermocouple type utilized.

Note: The Electrical Measurement value will be in the units that are selected. i.e. - Millivolts, volts, milliamps, or ohms.

1. Disconnect the sensor from the controller.
2. Record the Calibration Offset CAL parameter value in the Operations Page $OPER$, Analog Input Menu A , then set value to zero.
3. Wire the precision source to the appropriate controller input terminals to be calibrated. Do not have any other wires connected to the input terminals. Please refer to the Install and Wiring section of this manual for the appropriate connections.
4. Ensure the controller sensor type is programmed to the appropriate Sensor Type SEN to be utilized in the Setup Page SEt , Analog Input Menu A .
5. Enter Factory Page $FCTY$, Calibration Menu CAL via front panel or PM LEGACY™ Limit Configurator Software.
6. Select the Calibration CAL input instance to be calibrated. This corresponds to the analog input to be calibrated.
7. Set Electrical Input Slope EL to 1.000 and Electrical Input Offset EL to 0.000 (this will cancel any prior user calibration values)
8. Input a Precision Source Low value. Read Electrical Measurement value mV of controller via PM LEGACY™ Limit Configurator or RUI. This will be referred to as Electrical Measured Low. Record low value _____.
9. Input a Precision Source High value.
10. Read Electrical Measurement value mV of controller via PM LEGACY™ Limit Configurator or RUI. This will be referred to as Electrical Measured High. Record high value _____.
11. Calculated Electrical Input Slope = (Precision High – Precision Low) / (Electrical Measured High - Electrical Measured Low) Calculated Slope value _____
12. Calculated Electrical Input Offset = Precision Low - (Electrical Input Slope * Measured Low) Calculated Offset value _____.
13. Enter the calculated Electrical Input Slope EL and Electrical Input Offset EL into the controller.
14. Exit calibration menu.
15. Validate calibration process by utilizing a calibrator to the analog input.
16. Enter calibration offset as recorded in step 2 if required to compensate for sensor error.

Setting Electrical Input Slope EL to 1.000 and Electrical Input Offset EL to 0.000, restores factory calibration as shipped from factory.

Filter Time Constant

Filtering smooths an input signal by applying a first-order filter time constant to the signal. Filtering the displayed value makes it easier to monitor. Filtering the signal may improve the performance of PID control in a noisy or very dynamic system.

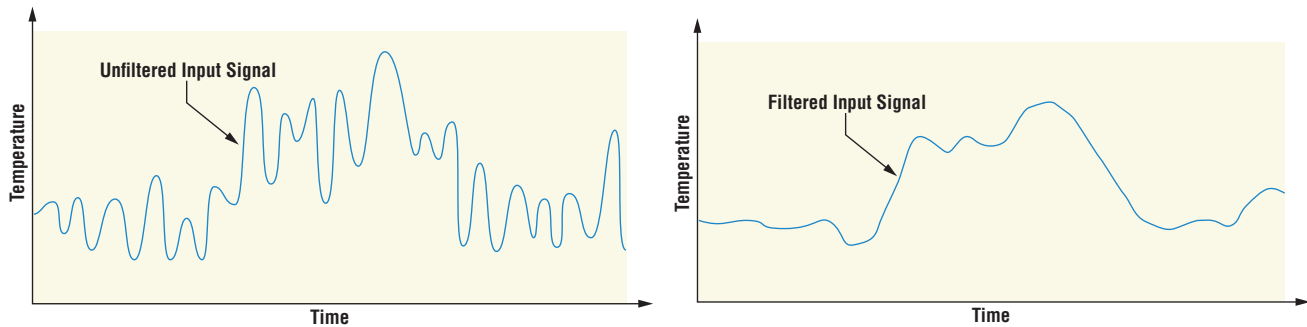

Adjust the filter time interval with Filter Time F_iL (Setup Page, Analog Input Menu). Example: With a filter value of 0.5 seconds, if the process input value instantly changes from 0 to 100 and remained at 100, the display will indicate 100 after five time constants of the filter value or 2.5 seconds.

Sensor Selection

You need to configure the controller to match the input device, which is normally a thermocouple, RTD or process transmitter.

Select the sensor type with Sensor Type SEn (Setup Page, Analog Input Menu).

Scale High and Scale Low

When an analog input is selected as process voltage or process current input, you must choose the value of voltage or current to be the low and high ends. For example, when using a 4 to 20 mA input, the scale low value would be 4.00mA and the scale high value would be 20.00mA. Commonly used scale ranges are: 0 to 20mA, 4 to 20mA, 0 to 5V, 1 to 5V and 0 to 10V.

You can create a scale range representing other units for special applications. You can reverse scales from high values to low values for analog input signals that have a reversed action. For example, if 50 psi causes a 4 mA signal and 10 psi causes a 20mA signal.

Scale low and high low values do not have to match the bounds of the measurement range. These along with range low and high provide for process scaling and can include values not measurable by the controller. Regardless of scaling values, the measured value will be constrained by the electrical measurements of the hardware. Select the low and high values with Scale Low SLo and Scale High SHi . Select the displayed range with Range Low rLo and Range High rHi (Setup Page, Analog Input Menu).

Range High and Range Low

With a process input, you must choose a value to represent the low and high ends of the current or voltage range. Choosing these values allows the controller's display to be scaled into the actual working units of measurement. For example, the analog input from a humidity transmitter could represent 0 to 100 percent relative humidity as a process signal of 4 to 20mA. Low scale would be set to 0 to represent 4 mA and high scale set to 100 to represent 20 mA. The indication on the display would then represent percent humidity and range from 0 to 100 percent with an input of 4 to 20mA. Select the low and high values with Range Low `r.Lo` and Range High `r.h.i` (Setup Page, Analog Input Menu).

Outputs

Retransmitting a Process Value or Set Point

The retransmit feature allows a process output to provide an analog signal that represents the set point or process value. The signal may serve as a remote set point for another controller or as an input for a chart recorder documenting system performance over time.

In choosing the type of retransmit signal the operator must take into account the input impedance of the device to be retransmitted to and the required signal type, either voltage or milliamps. Typically applications might use the retransmit option to record one of the variables with a chart recorder or to generate a set point for other controls in a multi-zone application.

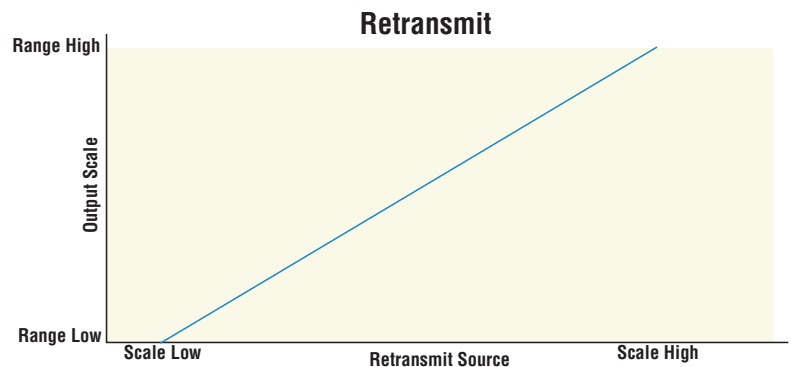

Output 3 can be ordered as process output. Select retransmit `r.PPE` as the Function `Fn` (Setup Page, Output Menu).

Set the output to volts `v.o.l.t` or milliamps `m.P.P.A` with Type `a.t.y`. Select the signal to retransmit with Retransmit Source `r.Sr`. Set the range of the process output with Scale Low `S.Lo` and Scale High `S.h.i`. Scale the retransmit source to the process output with Range Low `r.Lo` and Range High `r.h.i`.

When the retransmit source is at the Range Low value, the retransmit output will be at its Scale Low value. When the retransmit source is at the Range High value, the retransmit output will be at its Scale High value.

Resetting a Tripped Limit

Output 2 will always be a Form A (normally open) Mechanical Relay and it will always be internally tied to the limit function. When the limit is in a safe state the internal coil for this relay will be energized, therefore the relay will be closed. When a condition occurs that causes the limit to trip, the internal coil will deenergize causing the relay to latch open. When the condition that caused the limit to trip has been resolved, the relay will remain latched open until manually reset.

To check the firmware revision of your control do one of the following:

1. Cycle power to the control while observing the number in the top display (this momentary numerical display reflects the current installed firmware version).
2. Navigate to the Factory Page by simultaneously pushing and holding the Advance Key and the Reset Key for approximately 8 seconds and then use the up or down arrow key to navigate to the Diagnostic Menu. Once there, push the Advance Key twice where the revision `rEJ` will be shown in the lower display and the upper display will indicate the current firmware revision.
 - 2a. Navigate to the Setup Page and then the Limit Menu
 - 2b. Set Source Function A to the desired device that will reset the limit (Digital I/O or Function Key)
 - 2c. Define the Source Instance
3. Use a field bus protocol, i.e., Modbus, EtherNet/IP, etc...where a value of zero would be written to the associated address (navigate to the Operations Page and look for Clear Limit under the Limit Menu to find appropriate address).
4. Cycle the power to the controller.

Alarms

Alarms are activated when the output level, process value or temperature leaves a defined range. A user can configure how and when an alarm is triggered, what action it takes and whether it turns off automatically when the alarm condition is over. Configure alarm outputs in the Setup Page before setting alarm set points. Alarms do not have to be assigned to an output. Alarms can be monitored and controlled through the front panel or by using software.

Process Alarms

A process alarm uses one or two absolute set points to define an alarm condition. Select the type with Type `ALY` (Setup Page, Alarm Menu).

Set Points

The high set point defines the process value or temperature that will trigger a high side alarm. The low set point defines the temperature that will trigger a low side alarm. View or change alarm set points with Low Set Point `ALo` and High Set Point `ALh` (Operations Page, Alarm Menu).

Hysteresis

An alarm state is triggered when the process value reaches the high or low set point. Hysteresis defines how far the process must return into the normal operating range before the alarm can be cleared.

Hysteresis is a zone inside each alarm set point. This zone is defined by adding the hysteresis value to the low set point or subtracting the hysteresis value from the high set point. View or change hysteresis with Hysteresis `AhY` (Setup Page, Alarm Menu).

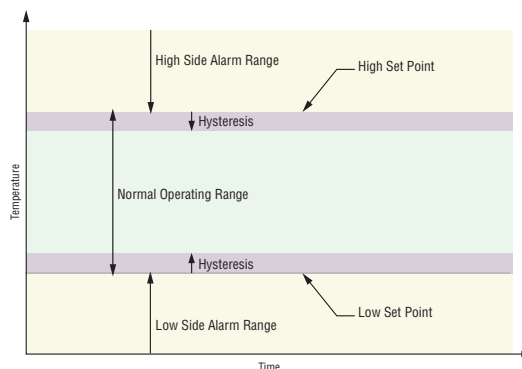

Alarm Set Points and Hysteresis

Latching

A latched alarm will remain active after the alarm condition has passed. It can only be deactivated by the user. An active message, such as an alarm message, will cause the display to toggle between the normal settings and the active message in the upper display and **ALERT** in the lower display. Push the Advance Key to display **ALARM** in the upper display and the message source in the lower display. Use the Up or Down key **▲▼** to scroll through possible responses, such as Clear **CLR** or Silence **SIL**. Then push the Advance or Reset key to execute the action.

See the Keys and Displays chapter and the Home Page chapter for more details. An alarm that is not latched (self-clearing) will deactivate automatically when the alarm condition has passed. Turn latching on or off with Latching **ALR** (Setup Page, Alarm Menu).

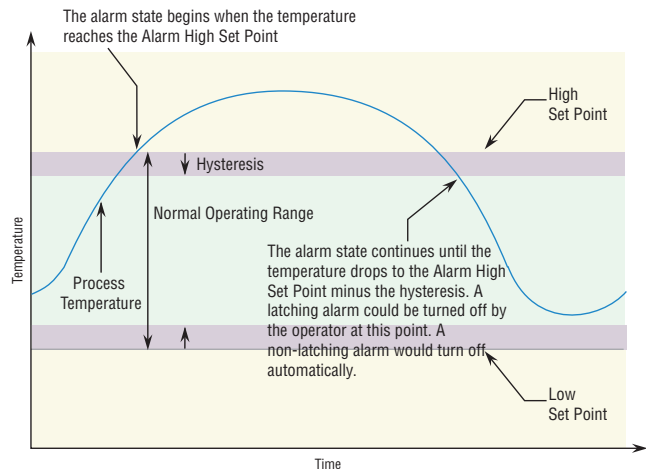

Alarm Response with Hysteresis

Silencing

If silencing is on the operator can disable the alarm output while the controller is in an alarm state. The process value or temperature has to enter the normal operating range beyond the hysteresis zone to activate the alarm output function again. An active message, such as an alarm message, will cause the display to toggle between the normal settings and the active message in the upper display and **ALERT** in the lower display.

1. Push the Advance Key to display **ALARM** in the upper display and the message source in the lower display.
2. Use the Up or Down key **▲▼** to scroll through possible responses, such as Clear **CLR** or Silence **SIL**. Then push the Advance or Reset key to execute the action.

See the Keys and Displays chapter and the Home Page chapter for more details. Turn silencing on or off with Silencing **RSI** (Setup Page, Alarm Menu).

Blocking

Blocking allows a system to warm up after it has been started up. With blocking on, an alarm is not triggered when the process temperature is initially lower than the low set point or higher than the high set point. The process temperature has to enter the normal operating range beyond the hysteresis zone to activate the alarm function. Turn blocking on or off with Blocking **ABL** (Setup Page, Alarm Menu).

Using Lockout and Password Security

If unintentional changes to parameter settings might raise safety concerns or lead to downtime, you can use the lockout feature to make them more secure. There are two methods of lockout that can be deployed, both of which are accessible from the Factory Page.

- Method 1- Change the value of the Read Lock **rLoE** (1 to 5) and Set Lock **sLoE** (0 to 5) prompts where the higher the value or setting for each translates to a higher security clearance (greater access).
- Method 2- Enable Password Security **PA5E** and then modify the Lock Level **LoEL** value which ranges from 1 to 5. See the section entitled “**Using Lockout Method 2**” for more detail.

Using Lockout Method 1 (Read and Set Lock)

All Pages have security levels assigned where two of those cannot be changed (Home and Setup). Defaults (factory settings) for each are shown below:

- Home Page = 1
- Operations Page = 2 (changeable to 1, 2 or 3)
- Setup Page = 4
- Profiling Page = 3 (changeable to 1, 2 or 3)
- Factory Page = 5*





* The Factory Page is always visible where all menus within it may or may not be visible/writable. For further detail see table “Factory Page Menus”.

The table below represents the various levels of lockout for the Set Lockout Security prompt `SLoC` and the Read Lockout Security prompt `rLoC`. Looking at the table, “Y” equates to yes (can write/read) where “N” equates to no (cannot write/read). The colored cells simply differentiate one level from the next while also showing the level where read/write is enabled. As stated previously, the Set Lockout has 6 levels (0 to 5) of security where the Read Lockout has 5 (1 to 5). Therefore, level “0” applies to Set Lockout only.

Lockout Security <code>SLoC</code> and <code>rLoC</code>						
Pages	Security Level					
	0	1	2	3	4	5
Home Page (cannot be changed)	N	Y	Y	Y	Y	Y
Operations Page	N	N	Y	Y	Y	Y
Setup Page (cannot be changed)	N	N	N	N	Y	Y
Factory Page	Y	Y	Y	Y	Y	Y

Being able to change the page security level for the Operations and Profile pages allows a user to give access to the Profile Page while locking out the Operations Page. The following example shows how the Lockout feature may be used to accomplish this:

Changing Security Levels:

1. From the Home Page, press and hold the Reset Key and the Advance Key for approximately six seconds. `CUSt` will appear in the upper display and `FfTY` will appear in the lower display.
2. Press the Up Key  until `LoC` appears in the upper display and `FfTY` will appear in the lower display.
3. Press the Advance Key until Lock Operations prompt `LoCo` appears in the bottom display.
4. Press the Up Key  to change the default value from `2` to `3`.
5. Press the Advance Key again and change the Lock Profiling prompt `LoCP` appears in the bottom display.
6. Press the Down Key  to change the default value from `3` to `2`.
7. Press the Advance Key until Read Lock `rLoC` appears in the bottom display.
8. Press the Down Key  to change the default value from `5` to `2`.
9. Press the Advance Key until Set Lock `SLoC` appears in the bottom display.
10. Press the Down Key  to change the default value from `5` to `4`.

With the above settings, the Home Page and the Profiling Page can be accessed, and all writable parameters can be written to. Due to the Read lock setting of 2, all pages with security levels greater than 2 will be locked out (inaccessible).

Another example of Method 1 lockout usage could be that an operator wants read access to all pages while allowing read/write access to the Home Page and the Lockout Menu only. To setup this scenario follow the steps below:

1. From the Home Page, press and hold the Reset Key and the Advance Key for approximately six seconds. **CUSE** will appear in the upper display and **FCEY** will appear in the lower display.
2. Press the Up Key  until **LoC** appears in the upper display and **FCEY** will appear in the lower display.
3. Press the Advance Key until Read Lock **rLoC** appears in the bottom display and change it to **5**.
4. Press the Advance Key until Set Lock **SLoC** appears in the bottom display and change it to **1**.

Although the Factory Page is always visible, some menus within it can be restricted.

Lockout Security SLoC and rLoC						
Factory Page Menus						
Menus	Security Level					
	0	1	2	3	4	5
Custom Menu	N	N	N	N	N	Y
Lockout Menu*	Y	Y	Y	Y	Y	Y
Diagnostic Menu**	N	Y	Y	Y	Y	Y
Calibration Menu	N	N	N	N	N	Y

* Using lockout Method 1 with **SLoC** set to 0, all writable parameters within the control will be inhibited (not writable) with two exceptions, **SLoC** and **rLoC**. As shown below, both of these parameters can always be seen and modified.

** Diagnostic Menu and all associated prompts are always visible and never writable

Lockout Security SLoC and rLoC						
Factory Page Menu Parameters						
Parameters	Security Level					
	0	1	2	3	4	5
LoC.o	N	Y	Y	Y	Y	Y
PAS.E	N	Y	Y	Y	Y	Y
rLoC	Y	Y	Y	Y	Y	Y
SLoC	Y	Y	Y	Y	Y	Y



Note: Using Method 1 Lockout all settings can be modified by anyone who knows how to find their way to the **SLoC** and **rLoC** parameters.

Using Lockout Method 2 (Password Enable)

It is sometimes desirable to apply a higher level of security to the control where a password would be required to access the control. If Password Enabled **PAS.E** in the Factory Page under the **LoC** Menu is set to on, an overriding Password Security will be in effect. Without the appropriate password, specified menus will remain inaccessible. Page and Menu access is defined in the Locked Access Level **LoC.L** prompt. On the other hand, a User with a password would have visibility restricted by the Read Lockout Security **rLoC**. As an example, with Password Enabled and the Locked Access Level **LoC.L** set to 1 and **rLoC** is set to 3, the available Pages for a User without a password would be limited to the Home and Factory Pages (locked level 1). If the User password is entered all pages would be accessible with the exception of the Setup Page as defined by level 3 access.

How to Enable Password Security

Follow the steps below:

1. From the Home Page, press and hold the Reset Key and the Advance Key for approximately six seconds. **CUSE** will appear in the upper display and **FEEY** will appear in the lower display.
2. Press the Up Key  until **LoE** appears in the upper display and **FEEY** will appear in the lower display.
3. Press the Advance Key until Password Enable **PA5E** appears in the bottom display and change it to **5**.
4. Press the Up Key  to turn it on. Once on, four new prompts will appear:
 - a. Locked Access Level **LoLL**, (1 to 5) corresponding to the lockout table above.
 - b. Rolling Password **roLL**, will change the Customer Code every time power is cycled.
 - c. User Password **PA5u**, which is needed for a User to acquire access to the control.
 - d. Administrator Password **PA5A**, which is needed to acquire administrative access to the control.

The Administrator can either change the User and or the Administrator password or leave them in the default state. Once Password Security is enabled they will no longer be visible to anyone other than the Administrator. In other words the Lock Menu **LoE** is not available to a User. As can be seen in the formula that follows either the User or Administrator will need to know what those passwords are to acquire a higher level of access to the control. Back out of this menu by pushing the Reset . Once out of the menu, the Password Security will be enabled.

How to Acquire Access to the Control





To acquire access to any inaccessible Pages or Menus, go to the Factory Page and enter the **ULoE** menu. Once there follow the steps below:

Note:

If Password Security (Password Enabled **PA5E** is On) is enabled the two prompts mentioned below in the first step will not be visible. If the password is unknown, call the individual or company that originally setup the control.

1. Acquire either the User Password **PA5u** or the Administrator Password **PA5A**.
2. Press the Advance key one time where the Code **CoDE** prompt will be visible.

Note:

- a. If the Rolling Password is off, press the Advance Key one more time where the Password **PA55** prompt will be displayed. Proceed to either step 7a or 8a. Pushing the Up or Down arrow Key   enter either the User or Administrator Password. Once entered, press and hold the Reset Key for two seconds to return to the Home Page.
 - b. If the Rolling Password **roLL** was turned on proceed on through steps 3 - 9.
3. Assuming the Code **CoDE** prompt (Public Key) is still visible on the face of the control simply push the Advance Key to proceed to the Password **PA55** prompt. If not, find your way back to the Factory Page as described above.
 4. Execute the calculation defined below (7b or 8b) for either the User or Administrator.
 5. Enter the result of the calculation in the upper display play by using the Up or Down arrow key   or use PM LEGACY™ Limit Configurator Software.
 6. Exit the Factory Page by pressing and holding the Reset Key for two seconds.

Formulas used by the User and the Administrator to calculate the Password follows:

Passwords equal:

7. User

- a. If Rolling Password `r_oLL` is Off, Password `PASS` equals User Password `PAS.u`.
- b. If Rolling Password `r_oLL` is On, Password `PASS` equals: $(PAS.u \times \text{code}) \text{ Mod } 929 + 70$

8. Administrator

- a. If Rolling Password `r_oLL` is Off, Password `PASS` equals User Password `PAS.A`.
- b. If Rolling Password `r_oLL` is On, Password `PASS` equals: $(PAS.A \times \text{code}) \text{ Mod } 997 + 1000$

Differences Between a User Without Password, User With Password and Administrator

- User without a password is restricted by the Locked Access Level `LoLL`.
- A User with a password is restricted by the Read Lockout Security `rLoC` never having access to the Lock Menu `LoC`.
- An Administrator is restricted according to the Read Lockout Security `rLoC` however, the Administrator has access to the Lock Menu where the Read Lockout can be changed.

Modbus - Using Programmable Memory Blocks

When using the Modbus RTU or Modbus TCP protocols, the PM control features a block of addresses that can be configured by the user to provide direct access to a list of 40 user configured parameters. This allows the user easy access to this customized list by reading from or writing to a contiguous block of registers.

To acquire a better understanding of the tables found in the back of this manual (See Appendix: (Modbus Programmable Memory Blocks) please read through the text below which defines the column headers used.

Assembly Definition Addresses

- Fixed addresses used to define the parameter that will be stored in the “Working Addresses”, which may also be referred to as a pointer. The value stored in these addresses will reflect (point to) the Modbus address of a parameter within the PM control.

Assembly Working Addresses

- Fixed addresses directly related to their associated “Assembly Definition Addresses” (i.e., Assembly Working Addresses 200 & 201 will assume the parameter pointed to by Assembly Definition Addresses 40 & 41).

When the Modbus address of a target parameter is stored in an “Assembly Definition Address” its corresponding working address will return that parameter’s actual value. If it’s a writable parameter, writing to its working register will change the parameter’s actual value. As an example, Modbus register 360 represents the Analog Input Value (See Operations Page, Analog Input Menu). If the value 360 is loaded into Assembly Definition Address 90 and value 361 is loaded into Assembly Definition Address 91, the value sensed by Analog Input 1 will also be stored in Modbus registers 250 and 251. Notice that by default this parameter is also stored in working registers 240 and 241 as well.

Note:

When modifying the Modbus Assembly registers, single register writes (function 06) are not allowed. Multiple register writes (function 16) must be used to modify the assembly.

The table identified as “Assembly Definition Addresses and Assembly Working Addresses” (see Appendix: Modbus Programmable Memory Blocks) reflects the assemblies and their associated addresses.

CIP - Communications Capabilities

With the introduction of the Common Industrial Protocol (CIP) a user can now collect data, configure a device and control industrial devices. CIP is an open protocol at the application layer fully managed by the Open DeviceNet Vendors Association (ODVA, <http://www.odva.org>). Being that this is an open protocol there are many independent vendors offering a wide array of devices to the end user. CIP provides the ability to communicate utilizing both implicit messaging (real-time I/O messaging), and explicit messaging (information/configuration messaging). For implicit communications using a PLC, simply configure the PM assembly size into the I/O structure of the PLC (See: CIP Implicit Assembly Structures). The assembly structures can also be changed by the user. Explicit communications requires the use of specific addressing information. DeviceNet requires that the node address be specified where EtherNet/IP requires just the Class, Instance and Attribute.

- Node address or MAC ID (0 - 63, DeviceNet only)
- Class ID (1 to 255)
- Instance ID (0 to 255)
- Attribute ID (1 to 255)

EtherNet/IP and DeviceNet are both based on CIP and use the same addressing scheme. In the following menu pages notice the column header identified as CIP. There you will find the Class, Instance and Attribute in hexadecimal, (decimal in parenthesis) which makes up the addressing for both protocols. The Watlow implementation of CIP does not support connected explicit messages but fully supports unconnected explicit messaging.

Rockwell Automation (RA) developed the DF1 serial protocol within the framework of the PCCC application protocol. With the introduction of CIP, the PCCC protocol was encapsulated within it to enable continued communication over Ethernet to the LEGACY™ RA programmable controllers, e.g., SLC, Micrologic and PLC-5 controllers equipped with Ethernet capabilities. The Watlow implementation of CIP also supports the PCCC protocol.

EtherNet/IP (Industrial Protocol) is a network communication standard capable of handling large amounts of data at speeds of 10 Mbps or 100 Mbps, and at up to 1,500 bytes per packet. It makes use of standard off-the-shelf Ethernet chip sets and the currently installed physical media (hardware connections). DeviceNet was the first field bus offering of the ODVA group and has been around for many years. DeviceNet can communicate at 125, 250 and 500 kilobytes per second with a maximum limitation of 64 nodes (0 to 63) on the network.

Note:

If the control is brought back to the factory defaults (See Appendix: CIP Implicit Assembly Structures) the user configured assemblies will be overwritten.

Note:

The maximum number of implicit input/output members using DeviceNet is 200. When using EtherNet/IP the maximum is 100.

CIP Implicit Assemblies

Communications using CIP (EtherNet/IP and DeviceNet) can be accomplished with any PM Integrated control equipped with either DeviceNet or EtherNet/IP communications cards. As was already mentioned, reading or writing when using CIP can be accomplished via explicit and or implicit communications. Explicit communications are usually executed via a message instruction within the PLC but there are other ways to do this as well outside of the focus of this document.

Implicit communications is also commonly referred to as polled communications. When using implicit communications there is an I/O assembly that would be read or written to. The default assemblies and the assembly size is embedded into the firmware of the PM control. Watlow refers to these assemblies as the T to O (Target to Originator) and the O to T (Originator to Target) assemblies where the Target is always the PM LEGACY™ Limit Controller and the Originator is the PLC or master on the network. The size of the O to T assembly is initially set to 40 (32-bit) members where the T to O assembly consists of 40 (32-bit) members. All assembly members are user configurable with the exception of the first T to O member. The first member of the T to O assembly is called the Device Status, it is unique and cannot be changed. If the module has been properly configured when viewing this 32-bit member in binary format bits 12 and 16 should always be set to 1 where all of the other bits should be 0. All other members that follow Device Status are user configurable. The Appendix of this User's Guide contains the PM implicit assemblies (See Appendix: (CIP Implicit Assembly Structures).

Modifying Implicit Assembly Members

To change any given member of either assembly (T to O or O to T) simply write the new class, instance and attribute (CIA) to the member location of choice. The CIP communications instance will always be instance 2.

Profibus DP - (Decentralized Peripherals)

This protocol is typically used to operate sensors and actuators via a centralized controller within industrialized production topologies. Data rates up to 12 Mbit/s on twisted pair cables and/or fiber optics are possible. This protocol is available in three functionally graded version; DP-V0, DP-V1 and DP-V2. It should be noted that Watlow products utilizing this protocol support DP-V0 and DP-V1 only. DP-V0 - provides the basic functionality of DP, including cyclic data exchange, station, module and channel specific diagnostics and four different interrupt types for diagnostics and process interrupts.

Cyclic Data refers to input/output data that is pre-configured to pass from the Profibus-DP Class 1 Master and the Slave at a known rate. Cyclic data is expected on both the sender and the receiver end of the message.

Note:

To use DP-V0 (cyclic data transfer) first configure and then register the General Station Description (GSD) file. Watlow provides a software tool allowing for total customization of the data to be read and or written to. Acquire this software tool (Profibus GSD Editor) via the CD that shipped with the product or, as an alternative, point your browser to: <http://www.watlow.com/en/resources-and-support/Technical-Library/Software-and-Demos> and navigate to the bottom of the page and click on "Software and Demos" to download the software.

Using the GSD Editor a user can configure up to a maximum of 244 I/O bytes that can be read or written to from Zone 1 through 16. DP-V1 - contains enhancements geared towards process automation, in particular acyclic data communication for parameter assignment, operation, visualization and interrupt control of intelligent field devices, in conjunction with cyclic user data communication.

Acyclic Data is a message that can be sent and or received at any time where they typically have a lower priority then cyclic messages. This type of messaging is typically used for the purpose of configuration or performing some sort of a diagnostic function.

Software Configuration

Using PM LEGACY™ Limit Configurator Software

To enable a user to configure the PM control using a personal computer (PC), Watlow has provided free software for your use. If you have not yet obtained a copy of this software and have a connection to the Internet, simply click on the link below and download the software from the Watlow web site free of charge.

<http://www.watlow.com/en/resources-and-support/Technical-Library/Software-and-Demos>

Once the software is installed double click on the PM LEGACY™ Limit Configurator icon placed on your desktop during the installation process. If you cannot find the icon follow the steps below to run the software:

1. Move your mouse to the “Start” button
2. Place the mouse over “All Programs”
3. Navigate to the “Watlow” folder and then the sub-folder “PM LEGACY™ Limit Configurator”
4. Click on PM LEGACY™ Limit Configurator to run.

The first screen that will appear is shown below.

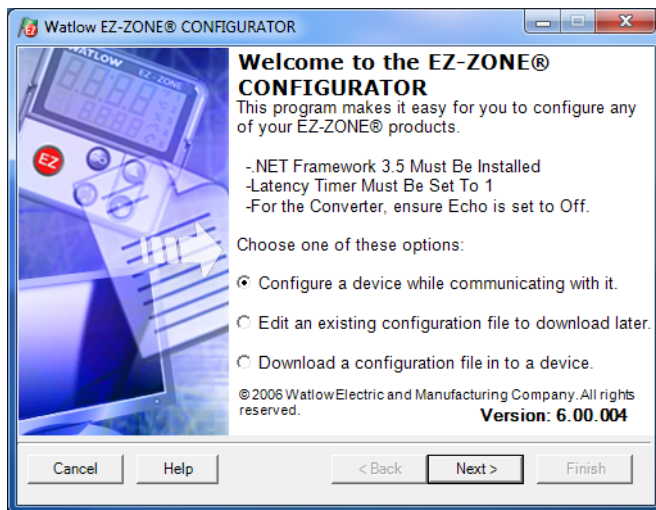

If the PC is already physically connected to the PM control click the next button to go on-line.

Note:

When establishing communications from PC to the PM controller, an interface converter will be required. The Standard Bus network uses EIA-485 as the interface. Most PCs today would require a USB to EIA-485 converter.

The PM must be configured using the keypad or serial EIA-485 connection. The software will not configure the controller via the other fieldbus options. As can be seen in the above screen shot the

software provides the user with the option of downloading a previously saved configuration as well as the ability to create a configuration off-line to download later. The screen shots that follow will take the user on-line.

After clicking the next button above it is necessary to define the communications port that will be used on the PC as shown to the right. Clicking on the drop down will allow the user to select the appropriate communications port. This will be the port assigned to the EIA-485 to USB converter when it was connected to the PC. The “Advanced” button allows the user to determine how many devices to look for on the network (1 to 17).

After clicking on the “Next” button, the software will scan the network for the zone addresses specified while showing the progress made (as shown in the graphic below. When complete the software will display all of the available devices found on the network as shown below.



Available Network Devices Displayed

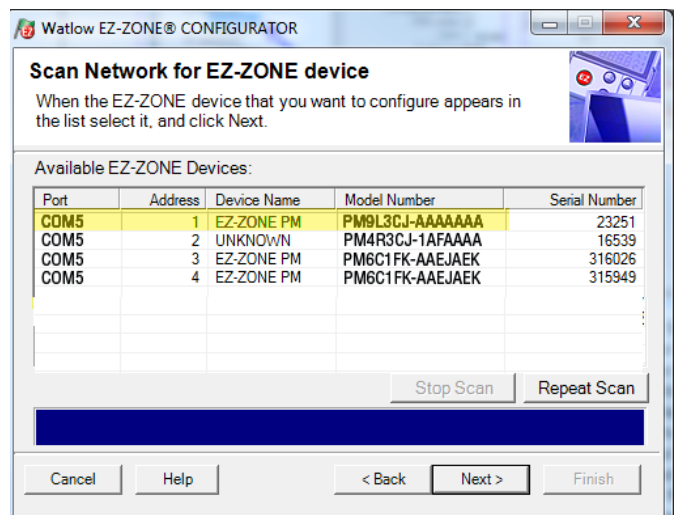
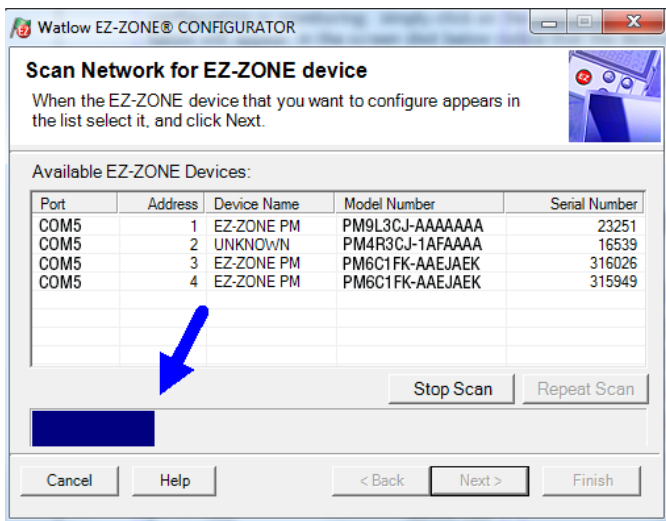

Any Watlow device on the network will appear in this window and would be available for the purpose of configuration or monitoring; simply click on the control of choice. After doing so, the screen below will appear. In the screen shot below notice that the device part number is clearly displayed at the top of the page (yellow highlight added for emphasis). When multiple Watlow devices are on the network it is important that the part number be noted prior to configuring so as to avoid making unwanted configuration changes to another controller. Looking closely at the left hand column (Parameter Menus) notice that it displays all of the available menus and associated parameters within the controller. The menu structure as laid out within this software follows:

- Setup - Operations - Factory

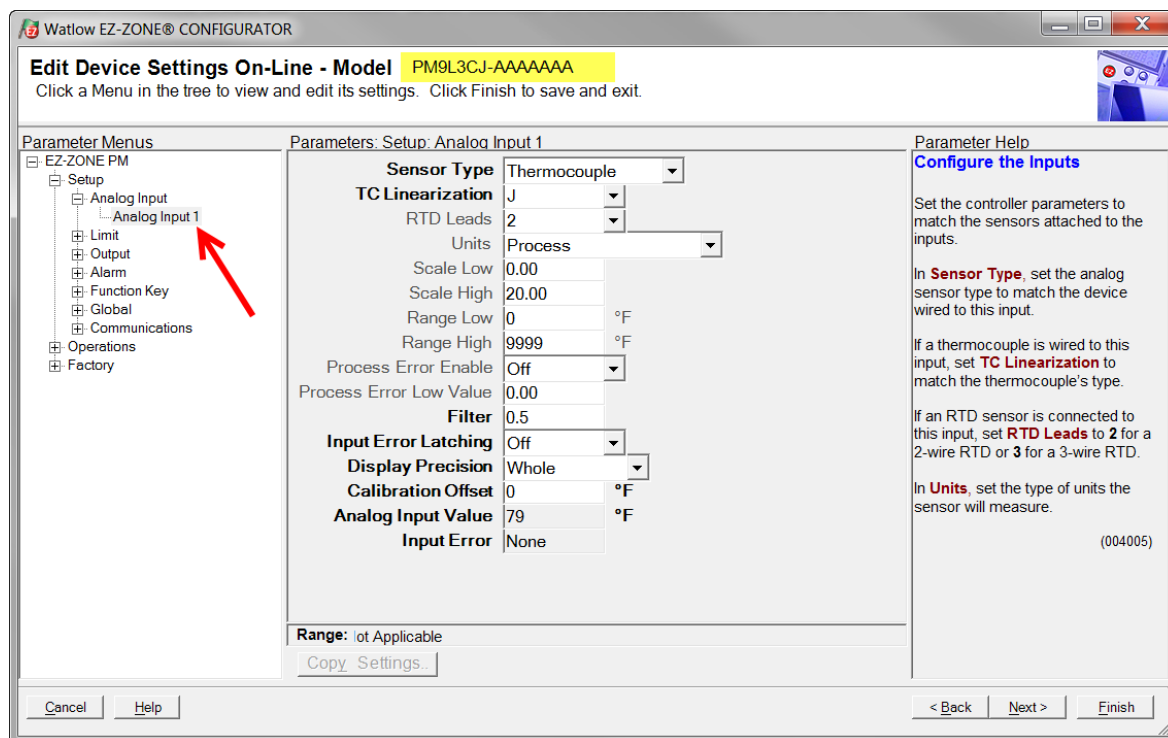

Navigating from one menu to the next is easy and clearly visible. Simply slide the scroll bar up or down to display the menu and parameter of choice. If there is a need to bring greater focus and clarity to the parameters of interest simply click on the negative symbol next to any of the Menu items. As an example, if it is desired to work within the Operations page click the negative sign next to Setup where the Setup Page will then collapse. Now click the plus sign next to Operations to find the menu items of choice without viewing unwanted menus and parameters.

Once the focus is brought to an individual parameter (single click of mouse) as is the case for Analog Input 1 in the left column; all that can be setup related to that parameter will appear in the center column. The grayed out fields in the center column simply mean that this does not apply for the type of sensor selected.

As an example, notice that when a thermocouple is selected, RTD Leads does not apply and is therefore grayed out. To speed up the process of configuration notice that at the bottom of the center column there is an option to copy settings. If Alarms 1 through 4 are to be configured the same, simply click on “Copy Settings” where a copy dialog box will appear allowing for quick duplication of all settings. Notice too, that by clicking on any of those items in the center column that context sensitive help will appear for that particular item in the right hand column. Lastly, when the configuration is complete, click the “Finish” button at the bottom right of the graphic on the previous page. The screen that follows this action can be seen above.

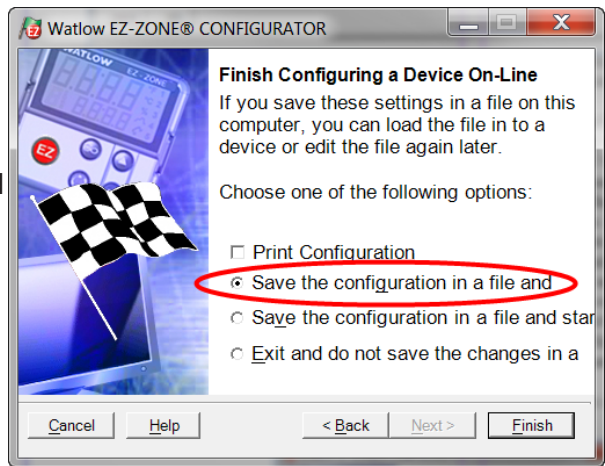

Although the PM controller now contains the configuration (because the previous discussion focused on doing the configuration on-line) it is suggested that after the configuration process is completed that the user save this file on the PC for future use. If for some reason someone inadvertently changed a setting without understanding the impact, it would be easy and perhaps faster to download a saved configuration back to the control versus trying to figure out what was changed. Of course, there is an option to exit without saving a copy to the local hard drive. After selecting Save above, click the “Finish” button once again. The screen below will then appear. When saving the configuration, note the location where the file will be placed (saved in) and enter the file name (File name) as well. The default path for saved files follows: Users\”Username”\My Documents\Watlow\LEGACY™ Configurator\Saved Configurations

The user can save the file to any folder of choice.

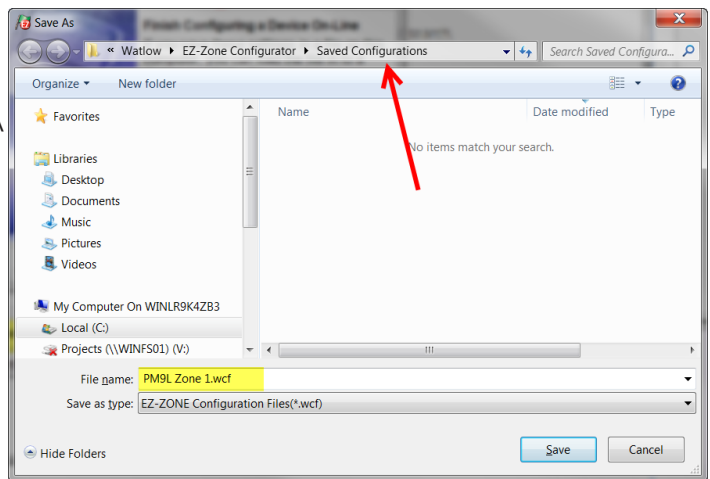

9

Chapter 9: Appendix

Troubleshooting Alarms, Errors and Control Issues

Indication	Description	Possible Cause(s)	Corrective Action
Alarm won't clear or reset	Alarm will not clear or reset with keypad or digital input	<ul style="list-style-type: none"> Latching is active Alarm set to incorrect output Alarm is set to incorrect source Sensor input is out of alarm set point range Alarm set point is incorrect Alarm is set to incorrect type Digital input function is incorrect 	<ul style="list-style-type: none"> Reset alarm when process is within range or disable latching Set output to correct alarm source instance Set alarm source to correct input instance Correct cause of sensor input out of alarm range Set alarm set point to correct trip point Set alarm to correct type: process, deviation or power Set digital input function and source instance
Alarm won't occur	Alarm will not activate output	<ul style="list-style-type: none"> Silencing is active Blocking is active Alarm is set to incorrect output Alarm is set to incorrect source Alarm set point is incorrect Alarm is set to incorrect type 	<ul style="list-style-type: none"> Disable silencing, if required Disable blocking, if required Set output to correct alarm source instance Set alarm source to correct input instance Set alarm set point to correct trip point Set alarm to correct type: process, deviation or power
Alarm Error <i>ALE 1</i> <i>ALE 2</i> <i>ALE 3</i> <i>ALE 4</i>	Alarm state cannot be determined due to lack of sensor input	<ul style="list-style-type: none"> Sensor improperly wired or open Incorrect setting of sensor type Calibration corrupt 	<ul style="list-style-type: none"> Correct wiring or replace sensor Match setting to sensor used Check calibration of controller
Alarm Low <i>ALL 1</i> <i>ALL 2</i> <i>ALL 3</i> <i>ALL 4</i>	Sensor input below low alarm set point	<ul style="list-style-type: none"> Temperature is less than alarm set point Alarm is set to latching and an alarm occurred in the past Incorrect alarm set point Incorrect alarm source 	<ul style="list-style-type: none"> Check cause of under temperature Clear latched alarm Establish correct alarm set point Set alarm source to proper setting

Indication	Description	Possible Cause(s)	Corrective Action
Alarm High <i>ALh1</i> <i>ALh2</i> <i>ALh3</i> <i>ALh4</i>	Sensor input above high alarm set point	<ul style="list-style-type: none"> • Temperature is greater than alarm set point • Alarm is set to latching and an alarm occurred in the past • Incorrect alarm set point • Incorrect alarm source 	<ul style="list-style-type: none"> • Check cause of over temperature • Clear latched alarm • Establish correct alarm set point • Set alarm source to proper setting
Error Input <i>Er.i1</i>	Sensor does not provide a valid signal to controller	<ul style="list-style-type: none"> • Sensor improperly wired or open • Incorrect setting of sensor type • Calibration corrupt 	<ul style="list-style-type: none"> • Correct wiring or replace sensor • Match setting to sensor used • Check calibration of controller
Ambient Error <i>Er.Ab</i>	Sensor does not provide a valid signal to controller	<ul style="list-style-type: none"> • Ambient error - cold junction circuitry not working 	<ul style="list-style-type: none"> • Return to factory for repair
Limit won't clear or reset	Limit will not clear or reset with keypad or digital input	<ul style="list-style-type: none"> • Sensor input is out of limit set point range • Limit set point is incorrect • Digital input function is incorrect 	<ul style="list-style-type: none"> • Correct cause of sensor input out of limit range • Set limit set point to correct trip point • Set digital input function and source instance
Limit Error <i>L.E1</i>	Limit state cannot be determined due to lack of sensor input, limit will trip	<ul style="list-style-type: none"> • Sensor improperly wired or open • Incorrect setting of sensor type • Calibration corrupt 	<ul style="list-style-type: none"> • Correct wiring or replace sensor • Match setting to sensor used • Check calibration of controller
Limit Low <i>L.L1</i>	Sensor input below low limit set point	<ul style="list-style-type: none"> • Temperature is less than limit set point • Limit outputs latch and require reset • Incorrect alarm set point 	<ul style="list-style-type: none"> • Check cause of under temperature • Clear limit • Establish correct limit set point
Limit High <i>L.h1</i>	Sensor input above high limit set point	<ul style="list-style-type: none"> • Temperature is greater than limit set point • Limit outputs latch and require reset • Incorrect alarm set point 	<ul style="list-style-type: none"> • Check cause of over temperature • Clear limit • Establish correct limit set point

Indication	Description	Possible Cause(s)	Corrective Action
No Display	<p>No display indication or LED illumination</p> <p>Either red or green display is blank. Check factory page, custom menu 1 and 2 for correct settings. Default is Custom 1 = Process and Custom-er 2 = Limit Status</p>	<ul style="list-style-type: none"> • Power to controller is off • Fuse open • Breaker tripped • Safety interlock switch open • Separate system limit control activated • Wiring error • Incorrect voltage to controller 	<ul style="list-style-type: none"> • Turn on power • Replace fuse • Reset breaker • Close interlock switch • Reset limit • Correct wiring issue • Apply correct voltage, check part number
No Serial Communication	Cannot establish serial communications with the controller	<ul style="list-style-type: none"> • Address parameter incorrect • Incorrect protocol selected • Baud rate incorrect • Parity incorrect • Wiring error • EIA-485 converter issue • Incorrect computer or PLC communications port • Incorrect software setup • Wires routed with power cables • Termination resistor may be required 	<ul style="list-style-type: none"> • Set unique addresses on network • Match protocol between devices • Match baud rate between devices • Match parity between devices • Correct wiring issue • Check settings or replace converter • Set correct communication port • Correct software setup to match controller • Route communications wires away from power wires • Place 120 Ω resistor across EIA-485 on last controller
Temperature runaway	Process value continues to increase or decrease past set point.	<ul style="list-style-type: none"> • Controller output incorrectly programmed • Thermocouple reverse wired • Controller output wired incorrectly • Short in heater • Power controller connection to controller defective • Controller output defective 	<ul style="list-style-type: none"> • Verify output function is correct (heat or cool) • Correct sensor wiring (red wire negative) • Verify and correct wiring • Replace heater • Replace or repair power controller • Replace or repair controller

Indication	Description	Possible Cause(s)	Corrective Action
Device Error <i>100</i> <i>rErr</i>	Controller displays internal malfunction message at power up.	<ul style="list-style-type: none"> • Controller defective • Sensor input over driven 	<ul style="list-style-type: none"> • Replace or repair controller • Check sensors for ground loops, reverse wiring or out of range values.
Menus inaccessible	Unable to access <i>SEt</i> , <i>oPEr</i> , <i>FCLY</i> menus or particular prompts in Home Page	<ul style="list-style-type: none"> • Security set to incorrect level • Digital input set to lockout keypad • Custom parameters incorrect 	<ul style="list-style-type: none"> • Check <i>LoC</i> settings in Factory Page and enter appropriate password in <i>ULoC</i> setting in Factory Page • Change state of digital input • Change custom parameters in Factory Page
Function Key/s do not work	Function Key/s do not activate required function	<ul style="list-style-type: none"> • Function Key function incorrect • Function Key function instance not correct • Keypad malfunction 	<ul style="list-style-type: none"> • Verify Function Key function in the Setup Menu • Correct and change the function instance if not correct • Replace or repair controller
Displayed value to low <i>uALL</i>	Value to low to be displayed in 4 digit LED display <-1999	<ul style="list-style-type: none"> • Incorrect setup 	<ul style="list-style-type: none"> • Check scaling of source data
Displayed value to high <i>uALh</i>	Value to high to be displayed in 4 digit LED display >9999	<ul style="list-style-type: none"> • Incorrect setup 	<ul style="list-style-type: none"> • Check scaling of source data

Detection of and Rules Around Abnormal Sensor Conditions	
Inputs	Detection of Abnormal Conditions
Thermocouple	
Shorted	No direct detection, Open loop firmware detection.
Open	Yes, Parasitic pull-up
Reversed	Yes, firmware detection
Current Source	
Shorted	Range limiting only
Open	Range limiting only
Reversed	Range limiting only
Voltage Source	
Open	Range limiting only
Shorted	Range limiting only
Reversed	Range limiting only
RTD	
S1 open	Yes, pulled up.
S2 open	Not implemented.
S3 open	Yes, pulled up.
S1 short to S2	Yes, pulled up
S1 short to S3	Yes, pulled down to under range.
S2 shorted to S3	Not implemented, Possible, monitor S2 voltage.
S1 and S2 open	Yes, pulled down to under range.
S1 and S3 open	Yes, S1 pulled up.
S2 and S3 open	Yes pulled up.
Thermistor	
S1 open	Yes, pulled up to sensor over range.
S3 open	Yes, pulled up to sensor over range.
S1 short to S3	Yes, pulled down to sensor under range.
S1 and S3 open	Yes, S1 pulled up to sensor over range.

Modbus - Programmable Memory Blocks

The Modbus assembly or programmable memory blocks consists of 40 pointers to the parameters of your choosing starting at Modbus register 40 (shown on the following page). The pointers are 32-bits long and are stored in two sequential registers. As an example, if it is desired to move an alias to the Analog Input of the PM (register 360) into pointer registers 40 and 41, a single multi-write command (0x10 function) would be used writing 360 into register 40 and 361 into register 41.

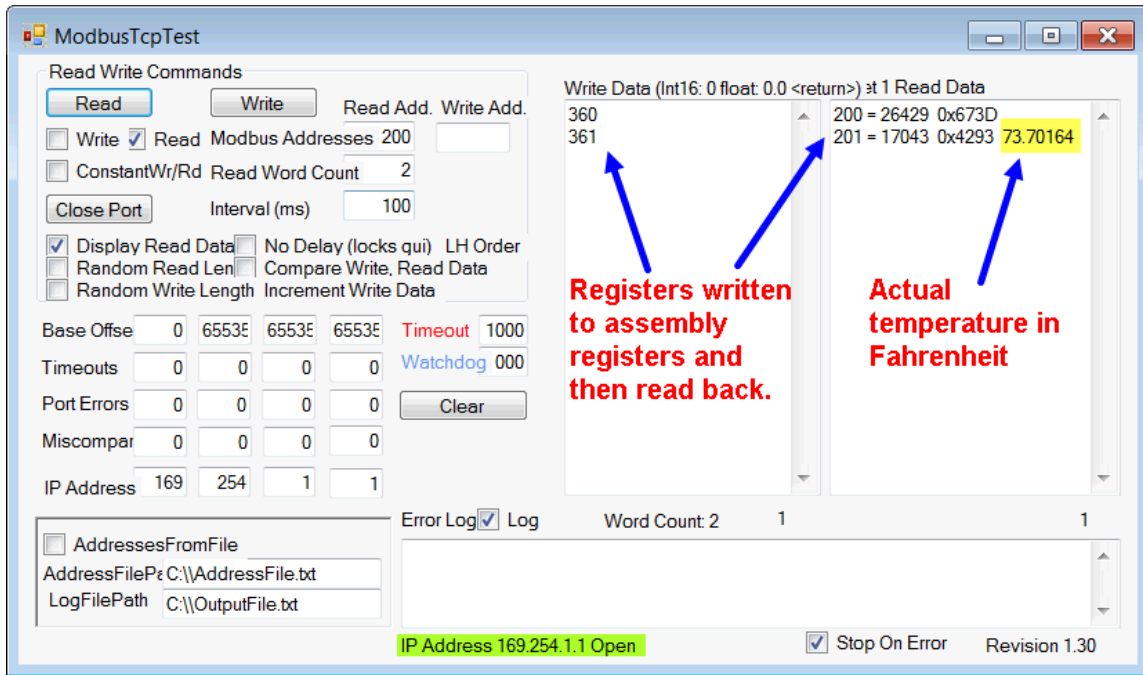

Once the parameters of choice have been defined and written to the specified pointer registers, the working registers will then represent the parameters written. In the example above, the 32-bit floating point analog input (360 and 361) was first written to registers 40 and 41 which in turn defines working registers 200 and 201 as Analog Input 1. As can be seen in the far right-hand column in the graphic above, reading back registers 200 and 201 the temperature, as detected by the first analog input is displayed.

The screen shot above was taken from a program that can be found on the Watlow Support Tools DVD (shipped with the product) as well as on the Watlow website. On the DVD, it can be found under "Utility Tools" and is identified as "Modbus TCP Diagnostic Program for PM LEGACY™ Limit, RM and ST". A similar program can be found here as well for Modbus RTU. If it is easier to go to the web to acquire this software, click on the link below and type "modbus" in the search field where both versions can be found and downloaded. <http://www.watlow.com/en/resources-and-support/Technical-Library/Software-and-Demos>

Modbus - Programmable Memory Blocks

Assembly Definition Addresses and Assembly Working Addresses

Assembly Definition Addresses	Assembly Working Addresses	Assembly Definition Addresses	Assembly Working Addresses
40 & 41	200 & 201	80 & 81	240 & 241
42 & 43	202 & 203	82 & 83	242 & 243
44 & 45	204 & 205	84 & 85	244 & 245
46 & 47	206 & 207	86 & 87	246 & 247
48 & 49	208 & 209	88 & 89	248 & 249
50 & 51	210 & 211	90 & 91	250 & 251
52 & 53	212 & 213	92 & 93	252 & 253
54 & 55	214 & 215	94 & 95	254 & 255
56 & 57	216 & 217	96 & 97	256 & 257
58 & 59	218 & 219	98 & 99	258 & 259
60 & 61	220 & 221	100 & 101	260 & 261
62 & 63	222 & 223	102 & 103	262 & 263
64 & 65	224 & 225	104 & 105	264 & 265
66 & 67	226 & 227	106 & 107	266 & 267
68 & 69	228 & 229	108 & 109	268 & 269
70 & 71	230 & 231	110 & 111	270 & 271
72 & 73	232 & 233	112 & 113	272 & 273
74 & 75	234 & 235	114 & 115	274 & 275
76 & 77	236 & 237	116 & 117	276 & 277
78 & 79	238 & 239	118 & 119	278 & 279

Modbus Map 1.

These require the user to change the defaults for limit when utilized.

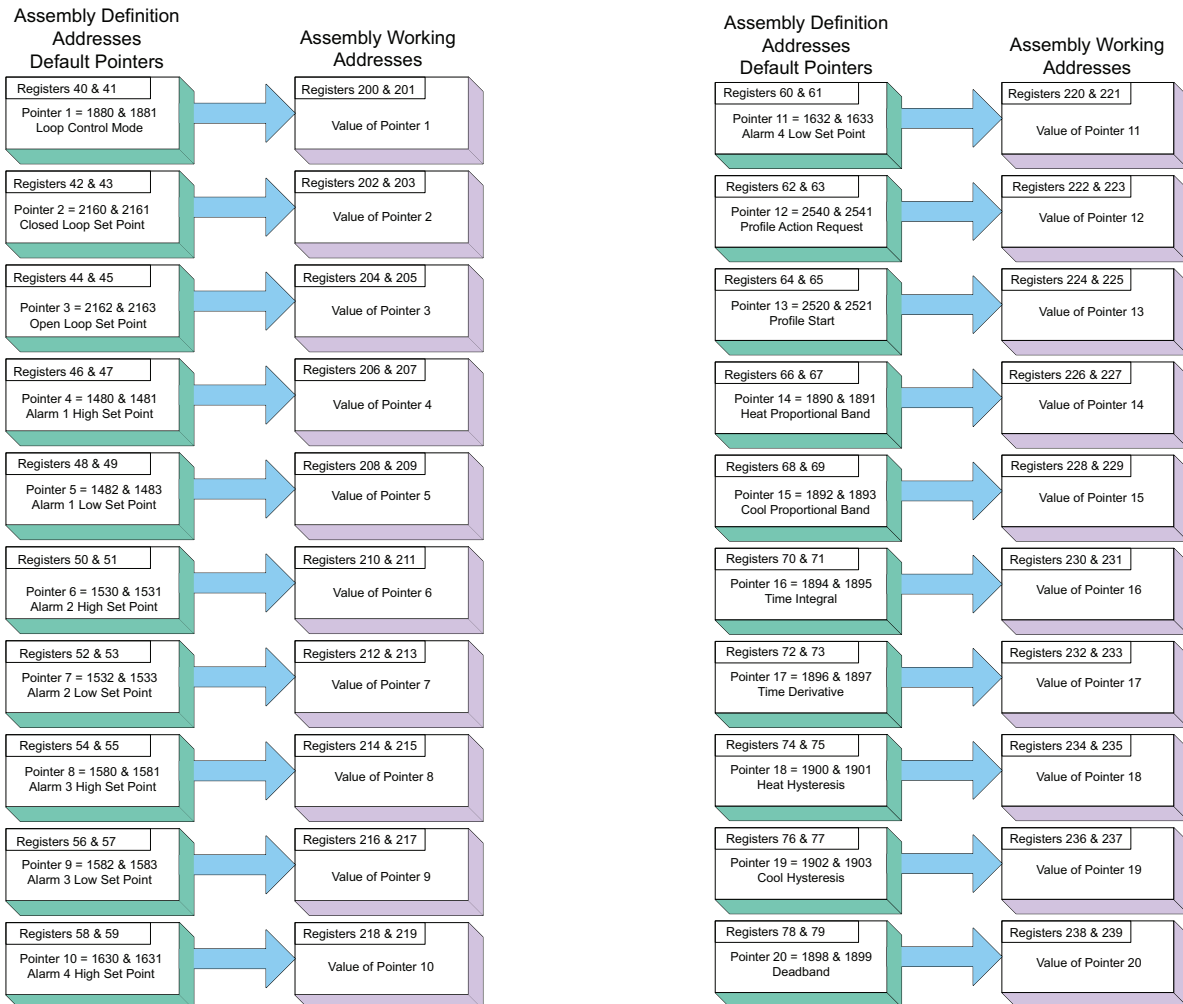

Modbus Default Assembly Structure 80-119

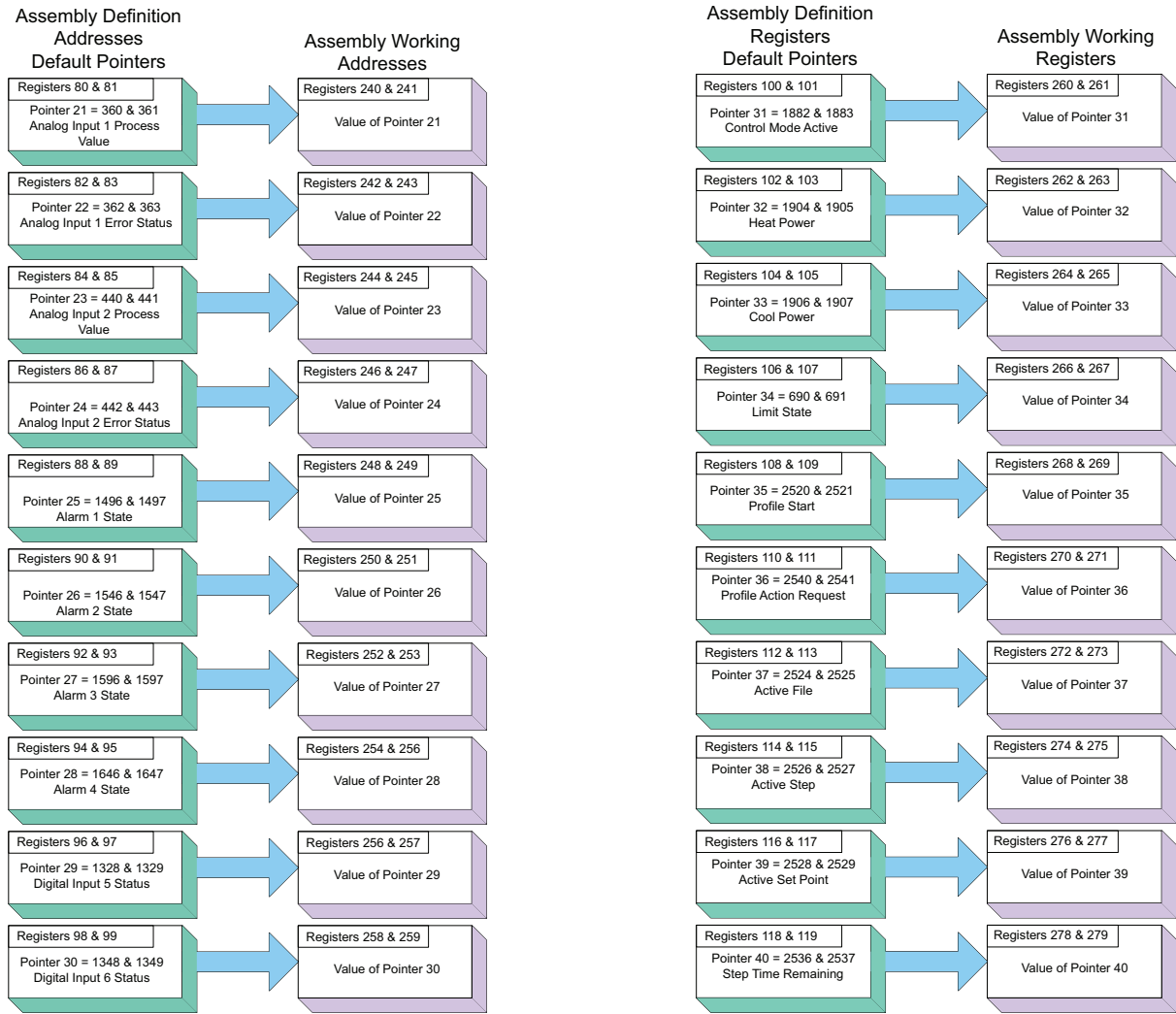

These require the user to change the defaults for Limit when utilized.

CIP Implicit Assembly Structures

CIP Implicit Assembly Structures Originator (Master) to Target (PML)					
Assembly Members	Assembly Class, Instance, Attribute	ST Data Type	Parameter	Parameter Class, Instance, Attribute	PLC Data Type
1	0x77, 0x01, 0x01	DINT	Control Loop 1, User Control Mode	0x97, 0x01, 0x01	DINT
2	0x77, 0x01, 0x02	DINT	Closed Loop Set Point	0x6B, 0x01, 0x01	REAL
3	0x77, 0x01, 0x03	DINT	Open Loop Set Point	0x6B, 0x01, 0x02	REAL
4	0x77, 0x01, 0x04	DINT	Alarm 1 - Alarm High Set Point	0x6D, 0x01, 0x01	REAL
5	0x77, 0x01, 0x05	DINT	Alarm 1 - Alarm Low Set Point	0x6D, 0x01, 0x02	REAL
6	0x77, 0x01, 0x06	DINT	Alarm 2 - Alarm High Set Point	0x6D, 0x02, 0x01	REAL
7	0x77, 0x01, 0x07	DINT	Alarm 2 - Alarm Low Set Point	0x6D, 0x02, 0x02	REAL
8	0x77, 0x01, 0x08	DINT	Alarm 3 - Alarm High Set Point	0x6D, 0x03, 0x01	REAL
9	0x77, 0x01, 0x09	DINT	Alarm 3 - Alarm Low Set Point	0x6D, 0x03, 0x02	REAL
10	0x77, 0x01, 0x0A	DINT	Alarm 4 - Alarm High Set Point	0x6D, 0x04, 0x01	REAL
11	0x77, 0x01, 0x0B	DINT	Alarm 4 - Alarm Low Set Point	0x6D, 0x04, 0x02	REAL
12	0x77, 0x01, 0x0C	DINT	Profile Action Request	0x7A, 0x01, 0x0B	DINT
13	0x77, 0x01, 0x0D	DINT	Profile Start	0x7A, 0x01, 0x01	DINT
14	0x77, 0x01, 0x0E	DINT	Heat Proportional Band	0x97, 0x01, 0x06	REAL
15	0x77, 0x01, 0x0F	DINT	Cool Proportional Band	0x97, 0x01, 0x07	REAL
16	0x77, 0x01, 0x10	DINT	Time Integral	0x97, 0x01, 0x08	REAL
17	0x77, 0x01, 0x11	DINT	Time Derivative	0x97, 0x01, 0x09	REAL
18	0x77, 0x01, 0x12	DINT	Heat Hysteresis	0x97, 0x01, 0x0B	REAL
19	0x77, 0x01, 0x13	DINT	Cool Hysteresis	0x97, 0x01, 0x0C	REAL
20	0x77, 0x01, 0x14	DINT	Dead Band	0x97, 0x01, 0x0A	REAL
21	0x77, 0x02, 0x15	DINT	None Specified	----	----
22	0x77, 0x02, 0x16	DINT	None Specified	----	----
23	0x77, 0x02, 0x17	DINT	None Specified	----	----
24	0x77, 0x02, 0x18	DINT	None Specified	----	----
25	0x77, 0x02, 0x19	DINT	None Specified	----	----
26	0x77, 0x02, 0x1A	DINT	None Specified	----	----
27	0x77, 0x02, 0x1B	DINT	None Specified	----	----
28	0x77, 0x02, 0x1C	DINT	None Specified	----	----
29	0x77, 0x02, 0x1D	DINT	None Specified	----	----
30	0x77, 0x02, 0x1E	DINT	None Specified	----	----
31	0x77, 0x02, 0x1F	DINT	None Specified	----	----
32	0x77, 0x02, 0x20	DINT	None Specified	----	----
33	0x77, 0x02, 0x21	DINT	None Specified	----	----
34	0x77, 0x02, 0x22	DINT	None Specified	----	----
35	0x77, 0x02, 0x23	DINT	None Specified	----	----
36	0x77, 0x02, 0x24	DINT	None Specified	----	----
37	0x77, 0x02, 0x25	DINT	None Specified	----	----
38	0x77, 0x02, 0x26	DINT	None Specified	----	----
39	0x77, 0x02, 0x27	DINT	None Specified	----	----
40	0x77, 0x02, 0x28	DINT	None Specified	----	----

These require the user to change the defaults for Limit when utilized.

Note:

PM revision 15 and above firmware allows for 40 implicit members. Revisions below 15, allow for a maximum of 20.

**CIP Implicit Assembly Structures
Target (PML) to Originator (Master)**

Assembly Members	Assembly Class, Instance, Attribute	ST Data Type	Parameter	Parameter Class, Instance, Attribute	PLC Data Type
----	Cannot be changed	Binary	Device Status	None	BIN
1	0x77, 0x02, 0x01	DINT	Analog Input 1, Analog Input Value	0x68, 0x01, 0x01	REAL
2	0x77, 0x02, 0x02	DINT	Analog Input 1, Input Error	0x68, 0x01, 0x02	REAL
3	0x77, 0x02, 0x03	DINT	Analog Input 2, Analog Input Value	0x68, 0x02, 0x01	REAL
4	0x77, 0x02, 0x04	DINT	Analog Input 2, Input Error	0x68, 0x02, 0x02	REAL
5	0x77, 0x02, 0x05	DINT	Alarm 1, Alarm State	0x6D, 0x01, 0x09	DINT
6	0x77, 0x02, 0x06	DINT	Alarm 2, Alarm State	0x6D, 0x02, 0x09	DINT
7	0x77, 0x02, 0x07	DINT	Alarm 3, Alarm State	0x6D, 0x03, 0x09	DINT
8	0x77, 0x02, 0x08	DINT	Alarm 4, Alarm State	0x6D, 0x04, 0x09	DINT
9	0x77, 0x02, 0x09	DINT	Event Status 1	0x6E, 0x01, 0x05	DINT
10	0x77, 0x02, 0x0A	DINT	Event Status 2	0x6E, 0x02, 0x05	DINT
11	0x77, 0x02, 0x0B	DINT	Control Mode Active	0x97, 0x01, 0x02	DINT
12	0x77, 0x02, 0x0C	DINT	Heat Power	0x97, 0x01, 0x0D	REAL
13	0x77, 0x02, 0x0D	DINT	Cool Power	0x97, 0x01, 0x0E	REAL
14	0x77, 0x02, 0x0E	DINT	Limit State	0x70, 0x01, 0x06	DINT
15	0x77, 0x02, 0x0F	DINT	Profile Start	0x7A, 0x01, 0x01	DINT
16	0x77, 0x02, 0x10	DINT	Profile Action Request	0x7A, 0x01, 0x0B	DINT
17	0x77, 0x02, 0x11	DINT	Current Profile	0x7A, 0x01, 0x03	DINT
18	0x77, 0x02, 0x12	DINT	Current Step	0x7A, 0x01, 0x04	DINT
19	0x77, 0x02, 0x13	DINT	Active Set Point	0x7A, 0x01, 0x05	REAL
20	0x77, 0x02, 0x14	DINT	Step Time Remaining	0x7A, 0x01, 0x09	DINT
21	0x77, 0x02, 0x15	DINT	None Specified	----	----
22	0x77, 0x02, 0x16	DINT	None Specified	----	----
23	0x77, 0x02, 0x17	DINT	None Specified	----	----
24	0x77, 0x02, 0x18	DINT	None Specified	----	----
25	0x77, 0x02, 0x19	DINT	None Specified	----	----
26	0x77, 0x02, 0x1A	DINT	None Specified	----	----
27	0x77, 0x02, 0x1B	DINT	None Specified	----	----
28	0x77, 0x02, 0x1C	DINT	None Specified	----	----
29	0x77, 0x02, 0x1D	DINT	None Specified	----	----
30	0x77, 0x02, 0x1E	DINT	None Specified	----	----
31	0x77, 0x02, 0x1F	DINT	None Specified	----	----
32	0x77, 0x02, 0x20	DINT	None Specified	----	----
33	0x77, 0x02, 0x21	DINT	None Specified	----	----
34	0x77, 0x02, 0x22	DINT	None Specified	----	----
35	0x77, 0x02, 0x23	DINT	None Specified	----	----
36	0x77, 0x02, 0x24	DINT	None Specified	----	----
37	0x77, 0x02, 0x25	DINT	None Specified	----	----
38	0x77, 0x02, 0x26	DINT	None Specified	----	----
39	0x77, 0x02, 0x27	DINT	None Specified	----	----
40	0x77, 0x02, 0x28	DINT	None Specified	----	----

These require the user to change the defaults for Limit when utilized.

As can be seen on the previous page, the PML Implicit Assembly defaults (factory settings) to a populated assembly structure. If it is desired to modify any of the given assembly members there are many software tools available to do so. It is outside of the scope of this document to describe how to use those. What can be found in this document is the process to build the assembly structure. If viewing this document electronically simply click on the link below to read the section entitled “ Modifying Implicit Assembly Members”. Otherwise, turn back to the table of contents to find the above named section.

Specifications

Line Voltage/Power

- 85 to 264VAC, 47 to 63Hz
- 20 to 28VAC, +10/-15%; 50/60Hz, $\pm 5\%$
- 12 to 40VDC
- 10VA (1/32 and 1/16 DIN)
- Data retention upon power failure via non-volatile memory
- Compliant with SEMI F47-0200, Figure R1-1 voltage sag requirements @ 24VAC or higher

Environment

- 0 to 149°F (-18 to 65°C) operating temperature
- -40 to 185°F (-40 to 85°C) storage temperature
- 0 to 90% RH, non-condensing

Accuracy

- Calibration accuracy and sensor conformity: $\pm 0.1\%$ of span, $\pm 1^\circ\text{C}$ @ the calibrated ambient temperature and rated line voltage
- Type S: 0.2%
- Type T below -50°C : 0.2%
- Calibration ambient temperature @ $77^\circ\text{F} \pm 5^\circ\text{F}$ ($25^\circ\text{C} \pm 3^\circ\text{C}$)
- Accuracy span: 1000°F (540°C) min.
- Temperature stability: $\pm 0.1^\circ\text{F}/^\circ\text{F}$ ($\pm 0.1^\circ\text{C}/^\circ\text{C}$) rise in ambient max.

Agency Approvals

- cULus® UL/EN/CSA C22.2 No 61010-1 Listed, File E185611
- CSA C22 No. 24, File 158031, class 4813-02, CSA approved
- UL® Type 4X indoor use front panel seal
- NEMA 4X, IP66, IP67 front panel seal
- cULus® ANSI/ISA 12.12.01-2007, CSA-C22.2 No. 213-1987, Class 1, Div. 2, Groups A, B, C and D, temperature code T4A, File E184390 (optional)
- CE, RoHS by design, W.E.E.E.
- FM Class 3545 (limit controls)

Controller

- User selectable heat/cool, on-off, P, PI, PD, PID or alarm action, not valid for limit controllers
- Auto-tune with control algorithm
- Control sampling rates: input = 10Hz, outputs = 10Hz
- Input and output capacity per controller type ordering information

Serial Communications

- Isolated communications
- Standard bus configuration protocol

Wiring Termination—Touch-Safe Terminals

- Input, power and controller output terminals are touch safe removable
- 12 to 22 AWG

Universal Input

- Thermocouple, grounded or ungrounded sensors, greater than $20\text{M}\Omega$ input impedance, $2\text{k}\Omega$ source resistance max.
- Non-isolated to switched dc and process output
- RTD 2- or 3-wire, platinum, 100Ω @ 0°C calibration to DIN curve ($0.00385 \Omega/\Omega/^\circ\text{C}$)
- Process, 4-20mA @ 100Ω , or 0-10VDC @ $20\text{k}\Omega$ input impedance; scalable

Functional Operating Range

- Type J: -346 to 2192°F (-210 to 1200°C)
- Type K: -454 to 2500°F (-270 to 1371°C)
- Type T: -454 to 750°F (-270 to 400°C)
- Type E: -454 to 1832°F (-270 to 1000°C)
- Type N: -454 to 2372°F (-270 to 1300°C)
- Type C: 32 to 4200°F (0 to 2315°C)
- Type D: 32 to 4200°F (0 to 2315°C)
- Type F: 32 to 2449°F (0 to 1343°C)
- Type R: -58 to 3214°F (-50 to 1767°C)
- Type S: -58 to 3214°F (-50 to 1767°C)
- Type B: 32 to 3300°F (0 to 1816°C)
- RTD (DIN): -328 to 1472°F (-200 to 800°C)
- Process: -1999 to 9999 units

Output Hardware

- Switched dc = 22 to 32VDC @ 30mA
- Open collector = 30VDC max. @ 100mA max. current sink
- Solid state relay (SSR), Form A, 0.5A @ 24VAC min., 264VAC max., opto-isolated, without contact suppression
- Electromechanical relay, Form C, 24 to 240VAC or 30VDC max., 5A resistive load, 100,000 cycles at rated load
- Electromechanical relay, Form A, 24 to 240VAC or 30VDC max., 5A resistive load, 100,000 cycles at rated load
- Output 2 is limit for limit models
- NO-ARC relay, Form A, 24 to 240VAC, 15A @ 122°F (50°C), resistive load, no VDC, 2 million cycles at rated load
- Universal process output: range selectable; 0 to 10VDC $\pm 15\text{mV}$ into a min. $1,000\Omega$ load with 2.5mV nominal resolution; 4 to 20mA $\pm 30\mu\text{A}$ into max. 800Ω load with $5\mu\text{A}$ nominal resolution; temperature stability 100ppm/ $^\circ\text{C}$

Operator Interface

- Dual 4 digit, 7 segment LED displays
- Typical display update rate 1Hz
- Advance, infinity (RESET), up and down keys plus an A/M-KEY for control or FUNCTION for limit (not available in 1/32 DIN)
- Infinity key is also labeled RESET on limit control models
- A/M-KEY on 1/16 DIN package automatically programmed as an auto/manual transfer mode function on PID models.

Input Type	Max Error @ 25 Deg C	Accuracy Range Low	Accuracy Range High	Units
J	±1.75	0	750	Deg C
K	±2.45	-200	1250	Deg C
T	±1.55	-200	350	Deg C
Input Type	Max Error @ 25 Deg C	Accuracy Range Low	Accuracy Range High	Units
N	±2.25	0	1250	Deg C
E	±2.10	-200	900	Deg C
R	±3.9	0	1450	Deg C
S	±3.9	0	1450	Deg C
B	±2.66	870	1700	Deg C
C	±3.32	0	2315	Deg C
D	±3.32	0	2315	Deg C
F (PTII)	±2.34	0	1343	Deg C
RTD, 100 ohm	±2.00	-200	800	Deg C
RTD, 1000 ohm	±2.00	-200	800	DegC
mV	±0.05	-50	50	mV
Volts	±0.01	0	10	Volts
mAdc	±0.02	0	20	mAmps DC
mAac	±5	0	50	mAmps AC

Operating Range			
Input Type	Range Low	Range High	Units
J	-210	1200	Deg C
K	-270	1371	Deg C
T	-270	400	Deg C
N	-270	1300	Deg C
E	-270	1000	Deg C
R	-50	1767	Deg C
S	-50	1767	Deg C
B	0	1816	Deg C
C	0	2315	Deg C
D	0	2315	Deg C
F (PTII)	0	1343	Deg C
RTD (100 ohm)	-200	800	Deg C
RTD (1000 ohm)	-200	800	Deg C
mV	0	50	mV
Volts	0	10	Volts
mAdc	0	20	mAmps DC

mAac	0	50	mAmps AC
Potentiometer, 1K range	0	1200	Ohms
Resistance, 5K range	0	5000	Ohms
Resistance, 10K range	0	10000	Ohms
Resistance, 20K range	0	20000	Ohms
Resistance, 40K range	0	40000	Ohms

Thermistor Input				
Input Type	Max Error @ 25 Deg C	Accuracy Range Low	Accuracy Range High	Units
Thermistor, 5K range	±5	0	5000	Ohms
Thermistor, 10K range	±10	0	10000	Ohms
Thermistor, 20K range	±20	0	20000	Ohms
Thermistor, 40K range	±40	0	40000	Ohms

- 0 to 40kΩ, 0 to 20kΩ, 0 to 10kΩ, 0 to 5kΩ
- 2.252kΩ and 10kΩ base at 25°C
- Linearization curves built in
- Third party Thermistor compatibility requirements

Base R @ 25C	Alpha Techniques	Beta THERM	YSI	Thermistor Curve
2.252K	Curve A	2.2K3A	004	A
10K	Curve A	10K3A	016	B
10K	Curve C	10K4A	006	C

2 Digital Input/Output Option - 2 DIO

- Digital input update rate 10Hz
 - DC voltage
 - Max. input 36V @ 3mA
 - Min. high state 3V at 0.25mA
 - Max. low state 2V
 - Dry contact
 - Min. open resistance 10k Ω
 - Max. closed resistance 50 Ω
 - Max. short circuit 13mA
- Digital output update rate 10Hz
 - SSR drive signal
 - Update rate 10 Hz
 - Maximum open circuit voltage is 22 to 25 V $\overline{\text{dc}}$
 - PNP transistor source
 - Typical drive; 21mA @ 4.5V for DO5, and 11mA @ 4.5V for DO6
 - Current limit 24mA for Output 5 and 12mA Output 6
 - Output 5 capable of driving one 3 - pole DIN-A-MITE
 - Output 6 capable of driving one 1 - pole DIN-A-MITE

Output Hardware

- Switched DC
 - Maximum open circuit voltage is 22 to 25V $\overline{\text{dc}}$
 - 30mA max. per single output / 40mA max. total per paired outputs (3 & 4)
 - Typical drive; 4.5V $\overline{\text{dc}}$ @ 30mA
 - Short circuit limited to <50mA
 - Use dc- and dc+ to drive external solid-state relay
 - 1-pole DIN-A-MITE: up to 4 in parallel or 4 in series
 - 2-pole DIN-A-MITE: up to 2 in parallel or 2 in series
 - 3-pole DIN-A-MITE: up to 2 in series
- Switched dc/open collector = 30V $\hat{\text{dc}}$ max. @ 100mA max. current sink
- Solid State Relay (SSR), FormA, 0.5A @ 24V \sim (ac) min., 240V $\hat{\text{ac}}$ (ac) max., 1A at 50°F linear derating to 0.5A at 149°F resistive, opto-isolated, without contact suppression, 120/240V \sim (ac) 20 VA pilot duty
 - Minimum holding current of 10mA
- Electromechanical relay, Form C, 5A, 24 to 240V \sim (ac) or 30V $\hat{\text{dc}}$ (dc) max., resistive load, 100,000 cycles at rated load, 125 VA pilot duty at 120/240V \sim (ac), 25 VA at 24V \sim (ac)
- Electromechanical relay, Form A, 5A, 24 to 240V \sim (ac) or 30V $\overline{\text{dc}}$ max., resistive load, 100,000 cycles at rated load, 125 VA pilot duty at 120/240V \sim (ac), 25 VA at 24V \sim (ac)
- NO-ARC relay, Form A, 15A, 24 to 240V \sim (ac), no V $\overline{\text{dc}}$ (dc), resistive load, 2 million cycles at rated load

- Universal process/retransmit, Output range selectable:

- 0 to 10V (dc) into a min. 1kΩ load

- 0 to 20mA into max. 800Ω load

Resolution

- dc ranges: 2.5mV nominal

- mA ranges: 5μA nominal

Calibration Accuracy

- dc ranges: ±15mV

- mA ranges: ±30μA

Temperature Stability

- 100 ppm/°C

Operator Interface

- Dual 4 digit, 7 segment LED displays
- Advance, infinity, up and down keys, plus optional programmable Function Key depending on model size
- Typical display update rate 1Hz
- RESET key substituted for infinity on all models including the limit control

Dimensions				
Size	Behind Panel (max.)	Width	Height	Display Character Height
1/32	101.6 mm (4.00 in)	53.3 mm (2.10 in)	30.9 mm (1.22 in)	Large: 7.62 mm (0.300 in) Small: 5.59 mm (0.220 in)
1/4	100.8 mm (3.97 in)	100.3 mm (3.95 in)	100.3 mm (3.95 in)	Large: 20.32 mm (0.800 in) Medium: 12.70 mm (0.500 in) Small: 10.16 mm (0.400 in)
1/16	101.6 mm (4.00 in)	53.3 mm (2.10 in)	53.3 mm (2.10 in)	Large: 10.16 mm (0.400 in) Small: 5.97 mm (0.235 in)
1/8 (H)	101.6 mm (4.00 in)	100.3 mm (3.95 in)	54.8 mm (2.16 in)	Large: 11.4 mm (0.450 in) Medium: 9.53 mm (0.375 in) Small: 7.62 mm (0.300 in)
1/8 (V)	101.6 mm (4.00 in)	54.8 mm (2.16 in)	100.3 mm (3.95 in)	Large: 11.4 mm (0.450 in) Medium: 9.53 mm (0.375 in) Small: 7.62 mm (0.300 in)

Weight	
1/32 DIN (PM3) • Controller: 127 g (4.5 oz.)	1/16 DIN (PM6) • Controller: 186 g (6.6 oz.)
User's Guide • User's Guide: 284.86 g (10.1 oz)	

Modbus® is a trademark of AEG Schneider Automation Inc.

EtherNet/IP™ is a trademark of ControlNet International Ltd. used under license by Open DeviceNet Vendor Association, Inc. (ODVA).

UL® is a registered trademark of Underwriters Laboratories Inc.

DeviceNet™ is a trademark of Open DeviceNet Vendors Association.

Note:

These specifications are subject to change without prior notice.

Ordering Information for Limit Controller Models



PM LEGACY Limit Model Configuration Information

① ②	③	④	⑤	⑥ ⑦	⑧	⑨	⑩ ⑪	⑫	⑬ ⑭
	Package Size	Primary Functions	Power Supply, Digital I/O	Output 1 and 2 Hardware Options	Comm. Options	Future Option	Output 3 and 4 Hardware Options	Model Selection	Custom Options
PM						A			

③ Package Size	
3 =	1/32 DIN (coming soon)
6 =	1/16 DIN

④ Primary Functions	
L =	Limit controller with universal input
M =	Limit controller with thermistor input

⑤ Power Supply, Digital Inputs/Outputs (I/O)	
1 =	100 to 240VAC
2 =	100 to 240VAC plus 2 digital I/O points (Not available on Express version)
3 =	20 to 28VAC or 12 to 40VDC
4 =	20 to 28VAC or 12 to 40VDC, plus 2 digital I/O points (Not available on Express version)

⑥ ⑦ Output 1 and 2 Hardware Options		
	Output 1	Output 2
AJ =	None	Mechanical relay 5A, Form A
CJ =	Switched dc/open collector	Mechanical relay 5A, Form A
EJ =	Mechanical relay 5A, Form C	Mechanical relay 5A, Form A

⑧ Communication Options	
Standard bus always included	
A =	None
B =	Bluetooth®
E =	EIA-485 Modbus® RTU and Bluetooth® (Not available on Express version)
F =	Modbus® RTU 232/485 and Bluetooth® (Not available on PM3 or Express version)
G =	EtherNet/IP™/Modbus® TCP and Bluetooth® (Not available on PM3 or Express version)
H =	DeviceNet™ and Bluetooth® (Not available on PM3 or Express version)
J =	PROFIBUS DP and Bluetooth® (Not available on PM3 or Express version)
1 =	EIA-485 Modbus® RTU (Not available on Express version)
2 =	EIA-232/485 Modbus® RTU (Not available on PM3 or Express version)
3 =	EtherNet/IP™/Modbus® TCP (Not available on PM3 or Express version)
5 =	DeviceNet™ (Not available on PM3 or Express version)
6 =	PROFIBUS DP (Not available on PM3 or Express version)
Note: Bluetooth® not available in all countries, contact factory.	

⑩ ⑪ Output 3 and 4 Hardware Options		
	Output 3	Output 4
AA =	None	None
AJ =	None	Mechanical relay 5A, Form A
AK =	None	SSR Form A, 0.5 A
CA =	Switched dc/open collector	None
CC =	Switched dc/open collector	Switched dc
CJ =	Switched dc/open collector	Mechanical relay 5A, Form A
CK =	Switched dc/open collector	SSR Form A, 0.5 A
EA =	Mechanical relay 5A, Form C	None
EC =	Mechanical relay 5A, Form C	Switched dc
EJ =	Mechanical relay 5A, Form C	Mechanical relay 5A, Form A
EK =	Mechanical relay 5A, Form C	SSR Form A, 0.5A
FA =	Universal process	None
FC =	Universal process	Switched dc
FJ =	Universal process	Mechanical relay 5A, Form A
FK =	Universal process	SSR Form A, 0.5A
KK =	SSR Form A, 0.5A	SSR Form A, 0.5A

Note: Only available on 1/16 DIN models if communication Options F, G, H, J or 2 thru 6 is ordered in previous digit, then Option AA must be ordered here.

⑫ Model Selection	
G =	PM LEGACY Version (Output 1 and 2 always isolated)
H =	PM LEGACY EXPRESS Version (Available in PM3 or PM6) (Output 1 and 2 always isolated)

⑬ ⑭ Custom Options	
WP =	Watlow logo face plate
WN =	No logo/no name face plate
AG =	Conformal coating

Watlow® and EZ-ZONE® are registered trademarks of Watlow Electric Manufacturing Company.
SMOOTH-TOUCH™ and EZ-LINK™ are trademarks of Watlow Electric Manufacturing Company.
UL® and cUL® are registered trademarks of Underwriter's Laboratories, Inc.
i-Phone® is a registered trademark of Apple Corporation.
Android™ is a trademark of Google LLC.

Powered by Possibility



To be automatically connected to the nearest North American Technical Sales Office:

1-800-WATLOW2 • www.watlow.com

International Technical Sales Offices:

Austria	+43 6244 20129 0	India	+91 40 6661 2700	Mexico	+52 442 256 2200
China	+86 21 3532 8532	Italy	+39 02 458 8841	Singapore	+65 6773 9488
France	+33 1 41 32 79 70	Japan	+81 3 3518 6630	Spain	+34 91 675 1292
Germany	+49 7253 9400 0	Korea	+82 2 2169 2600	Taiwan	+886 7 288 5168
				UK	+44 115 964 0777

©2020 Watlow Electric Manufacturing Company all rights reserved.

WIN-LEG-0720



Declaration of Conformity - Series EZ-ZONE® PM

WATLOW Electric Manufacturing Company

1241 Bundy Blvd. Winona, MN 55987 USA

Declares that the following product meets the essential requirements of the following European Union Directives by using the relevant standards show below to indicate compliance.

Designation: **Series EZ-ZONE® PM (Panel Mount)**
 Model Numbers: PM (3, 6, 8, 9 or 4)(Any Letter or number)(1, 2, 3 or 4)(A, C, E, F or K) (A, C, H, J or K) – (Any letter or number)(Any letter or number)(A, C, E, F or K)(A, C, H, J or K) (Any three letters or numbers)
 Classification: Temperature control, Installation Category II, Pollution degree 2, IP65
 Rated Voltage and Frequency: 100 to 240 V~ (ac 50/60 Hz) or 15 to 36 V=dc/ 24 V~ac 50/60 Hz
 Rated Power Consumption: 10 VA maximum PM3, PM6 Models.
 14 VA maximum PM8, PM9, PM4 Models

2014/30/EU Electromagnetic Compatibility Directive

EN 61326-1:2013

Electrical equipment for measurement, control and laboratory use – EMC requirements (Industrial Immunity, Class B Emissions).

IEC 61000-4-2:2008 Electrostatic discharge immunity
 IEC 61000-4-3:2007 +A1/2008, A2/2010 Radiated, radio-frequency electromagnetic field immunity 10V/M 80–1000 MHz, 3 V/M 1.4–2.7 GHz
 IEC 61000-4-4:2012 Electrical fast-transient / burst immunity
 IEC 61000-4-5:2014 +A1/2017 Surge immunity
 IEC 61000-4-6:2013 + Corrigendum 2015 Immunity to conducted disturbances induced by radio-frequency fields
 IEC 61000-4-11:2004 + A1/2017 Voltage dips, short interruptions and voltage variations immunity
 EN 61000-3-2:2014 Limits for harmonic current emissions for equipment ≤ 16 Amps per phase
 EN 61000-3-3:2013 + A1/2017 Voltage fluctuations and flicker ≤ 16 Amps per phase
 SEMI F47-0812 Specification for semiconductor sag immunity Figure R1-1

¹For mechanical relay loads, cycle time may need to be extended up to 160 seconds to meet flicker requirements depending on load switched and source impedance.

2014/35/EU Low-Voltage Directive

EN 61010-1:2010²

Safety Requirements of electrical equipment for measurement, control and laboratory use. Part 1: General requirements

² Compliance with 3rd Edition requirements with use of external surge suppressor installed on 230 Vac~ power line units. Recommend minimum 1000 V peak to maximum 2000 V peak, 70 joules or better part be used.

Compliant with 2011/65/EU RoHS2 Directive Per 2012/19/EU W.E.E.E Directive

Please Recycle Properly. Models PM(4, 8 or 9)E contain a type BR1225 coin cell battery which shall be recycled at end of life per 2006/66/EC Battery Directive as amended by 2013/56/EU Directive.

Models PM6XXXX – (B, E, F, G, H, J, K)XXXXXX where (X = any letter or number allowed above)

Include Bluetooth® wireless technology and have been reviewed to the following additional requirements.

2014/53/EU Radio Equipment Directive (RED)

EN 61010-1:2010 Safety Requirements of electrical equipment for measurement, control and laboratory use. Part 1: General requirements
 EN 61326-1:2013 Covering the essential requirements of article 3.1(a) or Directive 2014/53/EU Electrical equipment for measurement, control and laboratory use – EMC requirements (Industrial Immunity, Class A Emissions).
CAUTION: This equipment not intended for use in residential environments and may not provide adequate protection to radio reception in such environments.
 EN 301 489-1 V2.1.1 ElectroMagnetic Compatibility (EMC) standard for radio equipment and services; Part 1: Common technical requirements; Harmonized Standard covering the essential requirements of article 3.1(b) of Directive 2014/53/EU and the essential requirements of article 6 of Directive 2014/30/EU
 EN 301 489-17 V3.1.1 ElectroMagnetic Compatibility (EMC) standard for radio equipment and services; Part 17: Specific conditions for Broadband Data Transmission Systems; Harmonized Standard covering the essential requirements of article 3.1(b) of Directive 2014/53/EU
 EN 300 328 V1.9.1 Electromagnetic compatibility and Radio spectrum Matters (ERM); Wideband transmission systems; Data transmission equipment operating in the 2.4 GHz ISM band and using wide band modulation techniques; Harmonized EN covering the essential requirements of article 3.2 of the R&TTE Directive
 EN 300 328 V2.1.1 NVLAP Test Report 10928545H-A Additional Receiver blocking test for to cover requirements for 2014/53/EU. NVLAP Test Report 11649468H-E

Contains Module FCC ID: VPYLBZY Part 15C 2.
Contains Module IC: 772C-LBZY RSS 210

- Japanese Radio Law (日本電波法)
Type certification (工事設計認証)



R001-P00500

Output Power: Frequency Range 2402.0 - 2480.0
Output Power 0.001 Watts Antenna gain: -0.6 dBi PCB antenna

Doug Kuchta
Name of Authorized Representative
Director of Operations

Winona, Minnesota, USA
Place of Issue
May 2018

Signature of Authorized Representative

Bluetooth Enabled Product Statement

Bluetooth® Enabled Product

Models PM6XXX-(B, E, F, G, H or K)XXXXXX contain an embedded Bluetooth module.

Output Power: Frequency Range 2402.0 - 2480.0 Output Power 0.001 Watts

Antenna gain: -0.6 dBi PCB antenna

FCC

The transmitter module is mounted on the top of the display PC board partially under the LED display module. Visible when display removed from bezel.

Module FCC ID: VPYLBZY Part 15C 2.

Unit is assembled from tested components, complete system not tested.

NOTE: This equipment has been tested and found to comply with the limits for a Class B digital device, pursuant to Part 15 of the FCC Rules. These limits are designed to provide reasonable protection against harmful interference in a residential installation. This equipment generates, uses and can radiate radio frequency energy and, if not installed and used in accordance with the instructions, may cause harmful interference to radio communications. However, there is no guarantee that interference will not occur in a particular installation. If this equipment does cause harmful interference to radio or television reception, which can be determined by turning the equipment off and on, the user is encouraged to try to correct the interference by one or more of the following measures:

- Reorient or relocate the receiving antenna.
- Increase the separation between the equipment and receiver.
- Connect the equipment into an outlet on a circuit different from that to which the receiver is connected.
- Consult the dealer or an experienced radio/TV technician for help.

Industry Canada

Contains IC: **772C-LBZY**

Specification : RSS210

Japan



CE – See current Declaration of Conformity for full details.

Directive 2014/53/EU Radio Equipment Directive

Standards

EN 300 328 V1.9.1 NVLAP Test Report 10928545H-A

EN 300 328 V2.1.1 Receiver blocking test. NVLAP Test Report 11649468H-E



1241 Bundy Boulevard., Winona, Minnesota USA 55987
Phone: +1 (507) 454-5300, Fax: +1 (507) 452-4507 <http://www.watlow.com>