

### Leading edge Nanosensor Technology

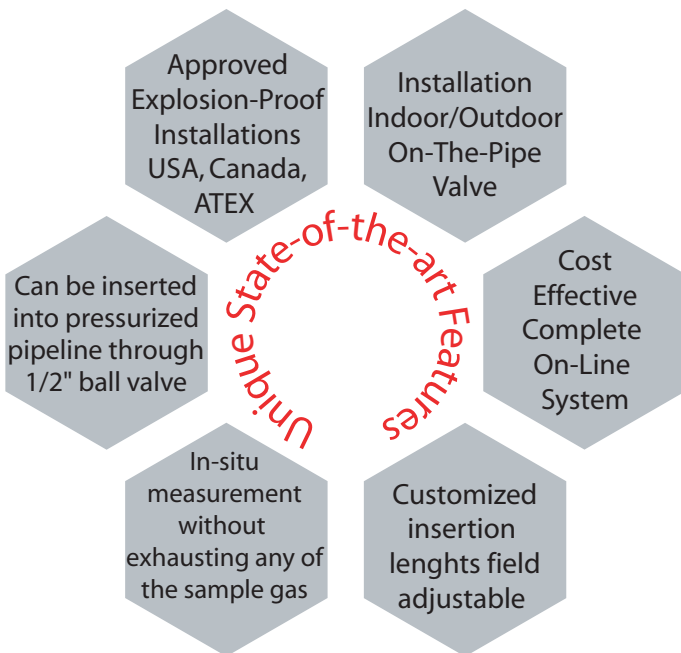

3/8" dia. probe has only 0.11 square inch cross sectional area, thus even at high pipeline pressures the probe can be inserted with minimal force

### more FEATURES

- -110°C to +20°C dewpoint Sensor
- Fast, Accurate and Repeatable
- Built-in temperature compensation
- 4/20 mA Loop Powered, 5 to 28VDC
- User-friendly HART compliant Interface
- Interfaces to Panel Meters
- Stainless Steel IP68 Explosionproof housing
- State-of-the-art electronics & software
- Units of measure: °C & °F dewpoint, ppmV, ppmW,  $\mu$ B H<sub>2</sub>O partial vapor pressure, Lbs/MMSCF in Natural Gas, g/m<sup>3</sup>
- Optional Built in Pressure Sensor
- 316 Stainless Steel & PTFE wetted parts
- Diverse Selection of Valve adapters

### APPLICATIONS

- Natural Gas
- Petrochemical
- Industrial Gases
- Power Generation
- Furnace Gas / Heat Treating
- Air Dryers
- Pharmaceutical
- Aerospace
- Medical



**PhyMetrix, Inc.**  
Moisture Measurement  
Innovation at work

- ◆ Test
- ◆ Measure
- ◆ Calibrate

- ◆ Quick
- ◆ Reproducible
- ◆ NIST Traceable

Proudly Designed, Developed and Manufactured in the USA



# PLMa-Probe-Ex

## PhyMetrix Loop Powered Explosion-Proof Moisture Probe



### Mechanical

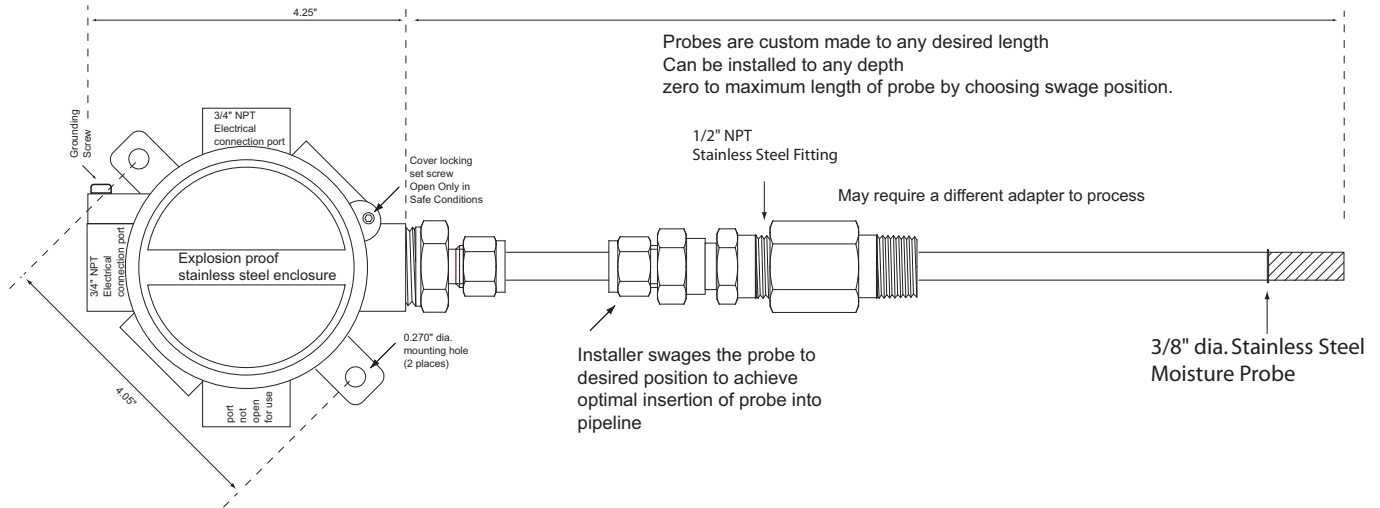

### PLMa Technical Specifications

Moisture Sensor	Range: -110°C to +20°C dewpoint ( -166°F to +68°F dewpoint ) Accuracy: ±2°C temperature corrected Response time: 95% of step change in 3 min.		
Temperature Sensor	Range: -40°C to +70°C Accuracy: ±2°C		
Ergonomics	Easy and quick installation, only standard tools required.		
Electrical	5VDC to 28VDC two wire loop operation 4mA to 20mA Housing isolated from 4-20mA Loop Measurement resolution of moisture sensor: 1pF resulting in less than 0.01°C 3/4"NPT cable entry, internal pluggable screw terminal connector  Use with two conductor cable 24AWG min. (for total cable length >1mile 20AWG min.) To meet CE requirements cable must be shielded. Built-in digital I/O for controlling relays		
Mechanical	All 316 Stainless Steel and PTFE wetted parts for fast response time. Enclosure all stainless steel construction IP68 protection when installed with appropriate conduit fittings Dimensions: 3.25" (82.6mm) diameter Explosion Proof enclosure 2.5" high Process threads: to be specified by customer Weight Total: 6 oz (0.17 Kg) Pressure: 5000 PSIA (345 Bar)		
Temperature Range	PLMa Analyzer: -20°C to +60°C	Electronics: -40°C to +85°C	Moisture Sensor: -20°C to +60°C
Miscellaneous Features	NIST traceable calibrations Units of measure: °C & °F dewpoint, ppmV, ppmW, µB H <sub>2</sub> O vapor pressure, grams of H <sub>2</sub> O / m <sup>3</sup> and Lbs H <sub>2</sub> O /10 <sup>6</sup> standard cubic feet in Natural Gas. (All units autoscaled) Digital & Analog: Two Wire 4/20mA loop with HART® Transmitter stores all HART setup		

ORDERING INFORMATION	Part Number
<b>PhyMetrix Loop-powered Moisture Analyzer Probe Ex</b> Model: <b>PLMaPrbEx</b>	<b>PLMaPrbEx</b>
Included Accessories: n/a	

Represented by: