



OPTISWIRL 4200 Quick Start

Vortex flowmeter

Electronic revision: ER 1.0.5_

1	Safety instructions	3
<hr/>		
2	Installation	4
<hr/>		
2.1	Intended use	4
2.2	Scope of delivery.....	6
2.3	Storage	6
2.4	Transport	7
2.5	Installation conditions	8
2.5.1	Prohibited installation when measuring liquids	9
2.5.2	Prohibited installation when measuring steam and gases.....	10
2.5.3	Pipelines with control valve	10
2.5.4	Preferred mounting position	11
2.6	Minimum inlet sections	12
2.7	Minimum outlet sections.....	13
2.8	Flow straightener	13
2.9	Installation	14
2.9.1	General installation notes.....	14
2.9.2	Installing devices in sandwich design	15
2.9.3	Installing devices in flange design	16
2.9.4	Mounting the field housing, remote version	17
2.10	Heat insulation.....	18
2.11	Turning the connection housing.....	19
2.12	Turning the display	20
3	Electrical connections	21
<hr/>		
3.1	Safety instructions.....	21
3.2	Connecting the signal converter	22
3.3	Electrical connections	23
3.3.1	Power supply.....	23
3.3.2	Current output	23
3.3.3	Current input.....	24
3.3.4	Binary output.....	24
3.3.5	Limit switch output	25
3.3.6	Pulse output / Frequency output	27
3.3.7	Status output.....	28
3.4	Connection of remote version	28
3.5	Grounding connections.....	30
3.6	Ingress protection	31

Warnings and symbols used



DANGER!

This information refers to the immediate danger when working with electricity.



DANGER!

These warnings must be observed without fail. Even partial disregard of this warning can lead to serious health problems and even death. There is also the risk of seriously damaging the device or parts of the operator's plant.



WARNING!

Disregarding this safety warning, even if only in part, poses the risk of serious health problems. There is also the risk of damaging the device or parts of the operator's plant.



CAUTION!

Disregarding these instructions can result in damage to the device or to parts of the operator's plant.



INFORMATION!

These instructions contain important information for the handling of the device.



HANDLING

- This symbol designates all instructions for actions to be carried out by the operator in the specified sequence.

➔ **RESULT**

This symbol refers to all important consequences of the previous actions.

Safety instructions for the operator



CAUTION!

Installation, assembly, start-up and maintenance may only be performed by appropriately trained personnel. The regional occupational health and safety directives must always be observed.



LEGAL NOTICE!

The responsibility as to the suitability and intended use of this device rests solely with the user. The supplier assumes no responsibility in the event of improper use by the customer. Improper installation and operation may lead to loss of warranty. In addition, the "Terms and Conditions of Sale" apply which form the basis of the purchase contract.



INFORMATION!

- Further information can be found on the supplied CD-ROM in the manual, on the data sheet, in special manuals, certificates and on the manufacturer's website.
- If you need to return the device to the manufacturer or supplier, please fill out the form contained on the CD-ROM and send it with the device. Unfortunately, the manufacturer cannot repair or inspect the device without the completed form.

2.1 Intended use

**CAUTION!**

Responsibility for the use of the measuring devices with regard to suitability, intended use and corrosion resistance of the used materials against the measured fluid lies solely with the operator.

**INFORMATION!**

This device is a Group 1, Class A device as specified within CISPR11:2009. It is intended for use in industrial environment. There may be potential difficulties in ensuring electromagnetic compatibility in other environments, due to conducted as well as radiated disturbances.

**INFORMATION!**

The manufacturer is not liable for any damage resulting from improper use or use for other than the intended purpose.

The vortex flowmeters are used for flow measurement of gases, vapours and liquids.

The devices are particularly suitable for the measurement of:

- Clean liquids with low viscosity (< 10 cP)
 - Hydrocarbons with low viscosity (< 10 cP)
 - Water
 - Chemicals with low corrosiveness
 - Saturated steam
 - Superheated steam, including CIP and SIP applications in the food industry
-
- The flow sensors are made from stainless steel 316 L (1.4404) or Hastelloy[®] C22.
 - In your project planning, please observe the data given in the corrosion tables.
 - The pressure-bearing parts have been designed and rated for stationary operation taking into account the maximum pressure and temperature.
 - Observe the data indicated on the nameplate for PS, TS and PT (PED 97/23/EC).
 - External forces and moments, caused e.g. by pipe stresses, have not been taken into account.

Primarily, volumetric flow and temperature are measured, with pressure measurement as an option. From these parameters the measuring device calculates the mass flow or standard volumetric flow using pre-programmed density data and then exports the measured values via various communication interfaces.

The devices are rated for the following flow velocities:

Liquids: DN15...DN300		V_{\min} : 0.25 m/s	0.8 ft/s	$V_{\min} [\text{m/s}] = 0.5 \times \sqrt{\frac{998}{\rho}} \quad \rho \left[\frac{\text{kg}}{\text{m}^3} \right]$	①
		V_{\max} : 10 m/s	32 ft/s	$V_{\max} [\text{m/s}] = 7 \times \left(\frac{998}{\rho} \right)^{0.47} \quad \rho \left[\frac{\text{kg}}{\text{m}^3} \right]$	②
Gases and steam:	DN15	V_{\min} : 3 m/s	10 ft/s	$V_{\min} [\text{m/s}] = 6 \times \sqrt{\frac{1.204}{\rho}} \quad \rho \left[\frac{\text{kg}}{\text{m}^3} \right]$	①
		V_{\max} : 45 m/s	147 ft/s	$V_{\max} [\text{m/s}] = 7 \times \left(\frac{998}{\rho} \right)^{0.47} \quad \rho \left[\frac{\text{kg}}{\text{m}^3} \right]$	②
	DN15C	V_{\min} : 3 m/s	10 ft/s	$V_{\min} [\text{m/s}] = 12 \times \sqrt{\frac{1.204}{\rho}} \quad \rho \left[\frac{\text{kg}}{\text{m}^3} \right]$	①
		V_{\max} : 55 m/s	180 ft/s	$V_{\max} [\text{m/s}] = 7 \times \left(\frac{998}{\rho} \right)^{0.47} \quad \rho \left[\frac{\text{kg}}{\text{m}^3} \right]$	②
	DN25	V_{\min} : 2 m/s	6.6 ft/s	$V_{\min} [\text{m/s}] = 6 \times \sqrt{\frac{1.204}{\rho}} \quad \rho \left[\frac{\text{kg}}{\text{m}^3} \right]$	①
		V_{\max} : 70 m/s	229 ft/s	$V_{\max} [\text{m/s}] = 7 \times \left(\frac{998}{\rho} \right)^{0.47} \quad \rho \left[\frac{\text{kg}}{\text{m}^3} \right]$	②
	DN25C	V_{\min} : 2 m/s	6.6 ft/s	$V_{\min} [\text{m/s}] = 12 \times \sqrt{\frac{1.204}{\rho}} \quad \rho \left[\frac{\text{kg}}{\text{m}^3} \right]$	①
		V_{\max} : 80 m/s	262 ft/s	$V_{\max} [\text{m/s}] = 7 \times \left(\frac{998}{\rho} \right)^{0.47} \quad \rho \left[\frac{\text{kg}}{\text{m}^3} \right]$	②
	DN40... DN300	V_{\min} : 2 m/s	6.6 ft/s	$V_{\min} [\text{m/s}] = 6 \times \sqrt{\frac{1.204}{\rho}} \quad \rho \left[\frac{\text{kg}}{\text{m}^3} \right]$	①
		V_{\max} : 80 m/s	262 ft/s	$V_{\max} [\text{m/s}] = 7 \times \left(\frac{998}{\rho} \right)^{0.47} \quad \rho \left[\frac{\text{kg}}{\text{m}^3} \right]$	②

- ① Use the larger value, according to the amount.
 ② Use the smaller value, according to the amount.



INFORMATION!

DN15C and DN25C have a robust flow sensor (signal pick-up) for harsh measuring conditions and higher maximum velocity compared to the standard version.

2.2 Scope of delivery



INFORMATION!

Inspect the packaging carefully for damages or signs of rough handling. Report damage to the carrier and to the local office of the manufacturer.



INFORMATION!

Do a check of the packing list to make sure that you have all the elements given in the order.



INFORMATION!

Look at the device nameplate to ensure that the device is delivered according to your order. Check for the correct supply voltage printed on the nameplate.

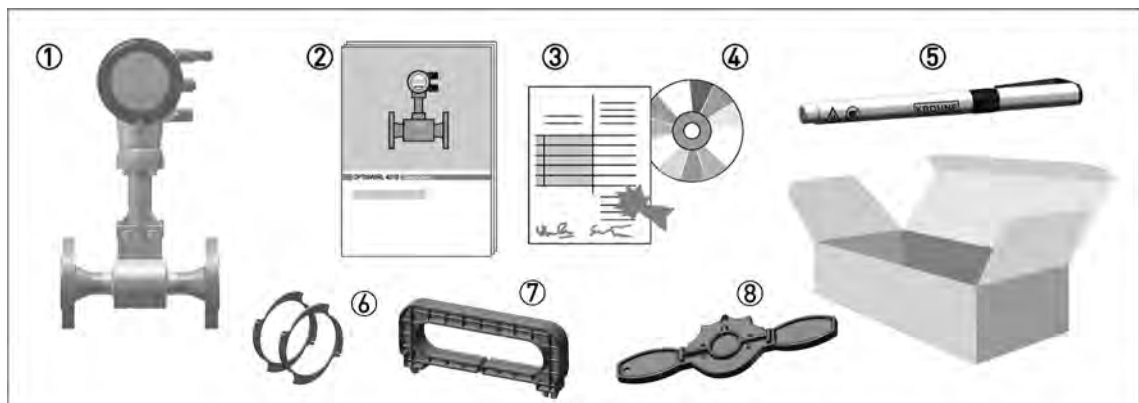

Figure 2-1: Scope of delivery

- ① Measuring device in ordered version
- ② Product documentation
- ③ Certificates, calibration report and parameter data sheet
- ④ CD with complete documentation
- ⑤ Bar magnet
- ⑥ Centering rings (only for sandwich devices)
- ⑦ Handle to pull off the display
- ⑧ Key for opening the front and rear cover

2.3 Storage

- Store the device in a dry, dust-free location.
- Avoid extended direct exposure to the sun.
- Store the device in the original packaging.
- The permissible storage temperature for standard devices is $-40...+85^{\circ}\text{C}$ / $-40...+185^{\circ}\text{F}$.

2.4 Transport

- Use lifting straps wrapped around both process connections for transport.
- Do not lift measuring devices by the signal converter housing for transport.
- Never lift the measuring device by the pressure sensor.
- Do not use lifting chains as they may damage the housing.

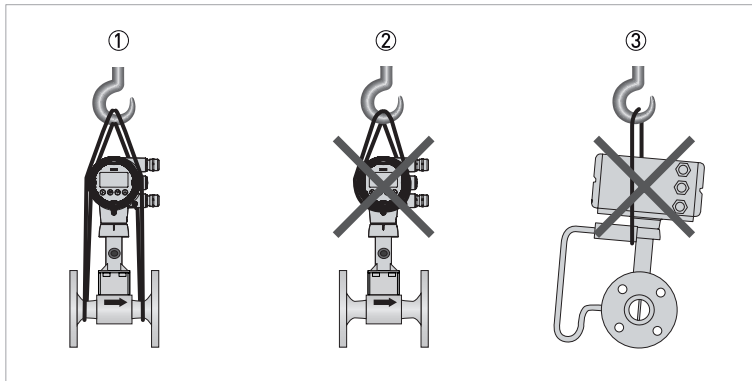

Figure 2-2: Transport instructions



CAUTION!

Non-secured devices can pose risk of injury. The centre of mass of the device is often higher than the point at which the lifting straps are attached. Prevent the measuring device from sliding or rotating accidentally.

2.5 Installation conditions



INFORMATION!

For accurate volumetric flow measurement the measuring device needs a completely filled pipe and a fully developed flow profile.



CAUTION!

Any vibration will distort the measuring result. That is why any vibrations in the pipeline must be prevented through suitable measures.



CAUTION!

Procedures to carry out before installing the device:

- Nominal diameter of connection pipe flange = nominal flange diameter of pipe!
- Use flanges with smooth holes, e.g. welding neck flanges.
- Align carefully the holes of the connecting flange and the flowmeter flange.
- Check the compatibility of the gasket material with the process product.
- Make sure that the gaskets are arranged concentrically. The flange gaskets must not project into the pipe cross-section.
- The flanges have to be concentric.
- There must not be any pipe bends, valves, flaps or other internals in the immediate inlet run.
- Devices in sandwich version may only be installed using centering rings.
- Never install the device directly behind piston compressors or rotary piston meters.
- Do not lay signal cables directly next to cables for the power supply.



INFORMATION!

If there is a risk of water hammers in steam networks, appropriate condensate separators must be installed. Suitable measures must be taken to avoid water cavitation if it is a possible risk.

Sunshades

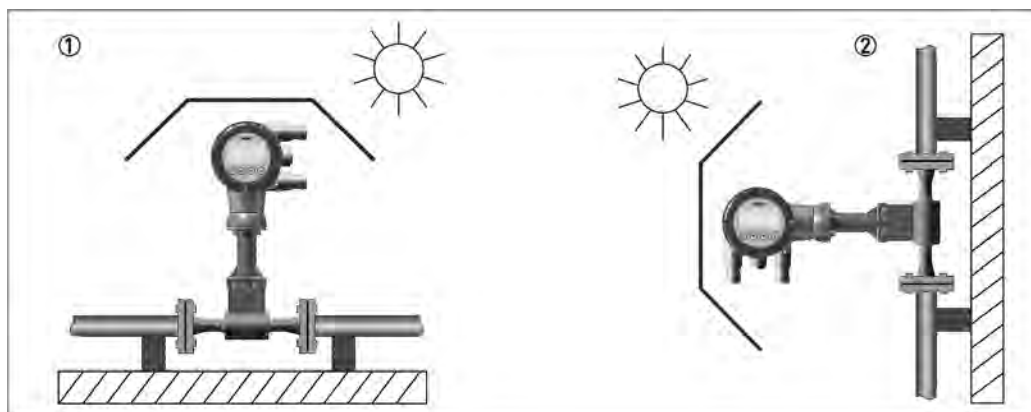

Figure 2-3: Installation recommendations

- ① Horizontal mounting
- ② Vertical mounting

The meter MUST be protected from strong sunlight.
A sunshade is available from the manufacturer as an option.

2.5.1 Prohibited installation when measuring liquids

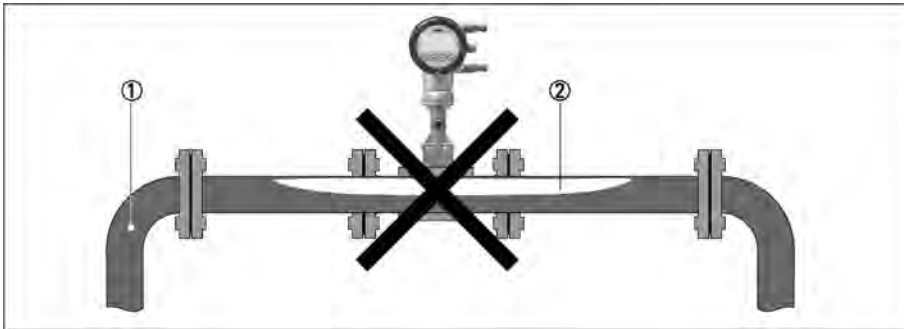

Figure 2-4: Upper pipe bend



CAUTION!

Prohibited: Installing the device in an upper pipe bend ①, because there is a risk of gas bubbles ② forming. Gas bubbles can lead to pressure surges and inaccurate measurement.

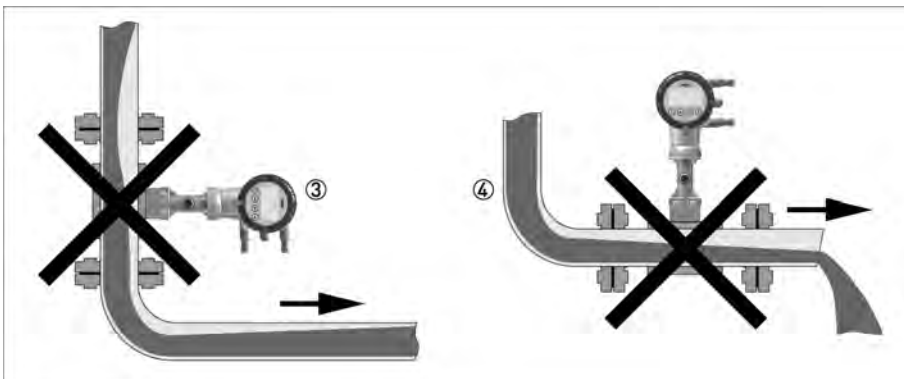

Figure 2-5: Downstream pipe and outlet



CAUTION!

Installing the device in a downstream pipe ③ or upstream pipe of an outlet ④. There is the risk of partially filled pipes leading to inaccurate measurements.

2.5.2 Prohibited installation when measuring steam and gases

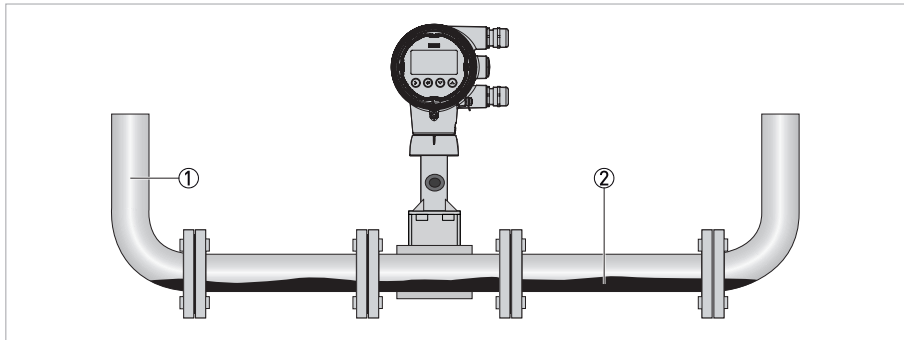

- ① Lower pipe bends
- ② Condensate

**DANGER!**

Prohibited: Installing the device in a lower pipe bend ①, because there is a risk of condensate forming ②.

Condensate can lead to cavitation and inaccurate measurement. Under certain circumstances the device can be destroyed and the measured product can leak.

2.5.3 Pipelines with control valve

**INFORMATION!**

To ensure smooth and correct measurement, the manufacturer recommends not installing the measuring device downstream from a control valve. This would run the risk of vortex formation, which would distort the measuring result.

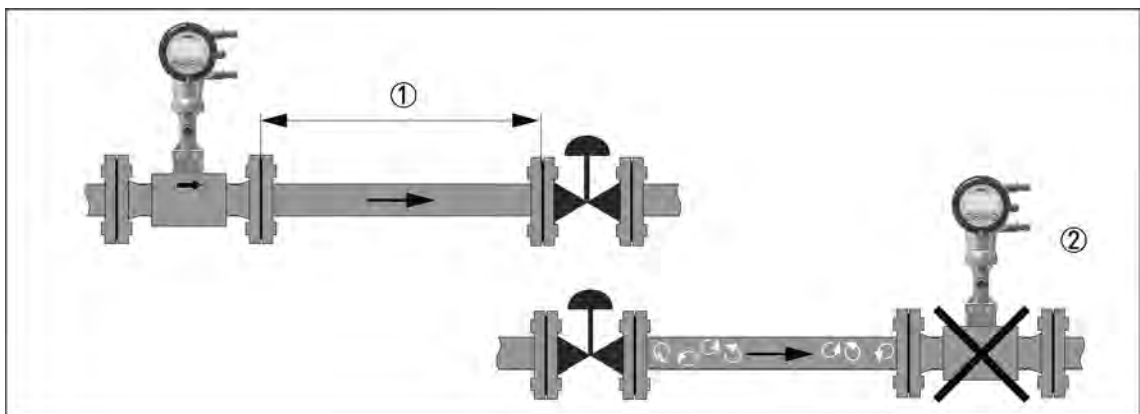

Figure 2-6: Pipeline with control valve

- ① Recommended: installing the device before the control valve at a distance of ≥ 5 DN
- ② Not recommended: Installing the flowmeter directly downstream of control valves, due to vortex formation.

2.5.4 Preferred mounting position

Preferred mounting position

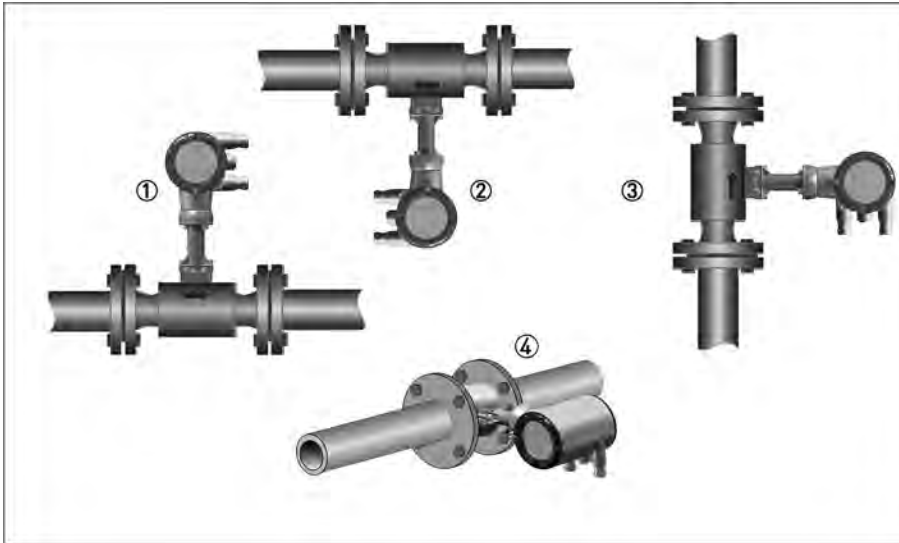

Figure 2-7: Mounting position

- ① Above a horizontal pipe
- ② Underneath a horizontal pipe (not permitted with lines at risk of condensate forming)
- ③ On a vertical pipe
- ④ Horizontal pipeline with signal converter-orientation 90° to the side



INFORMATION!

Depending on the installation position, you may have to rotate the display and/or the connection housing.

2.6 Minimum inlet sections

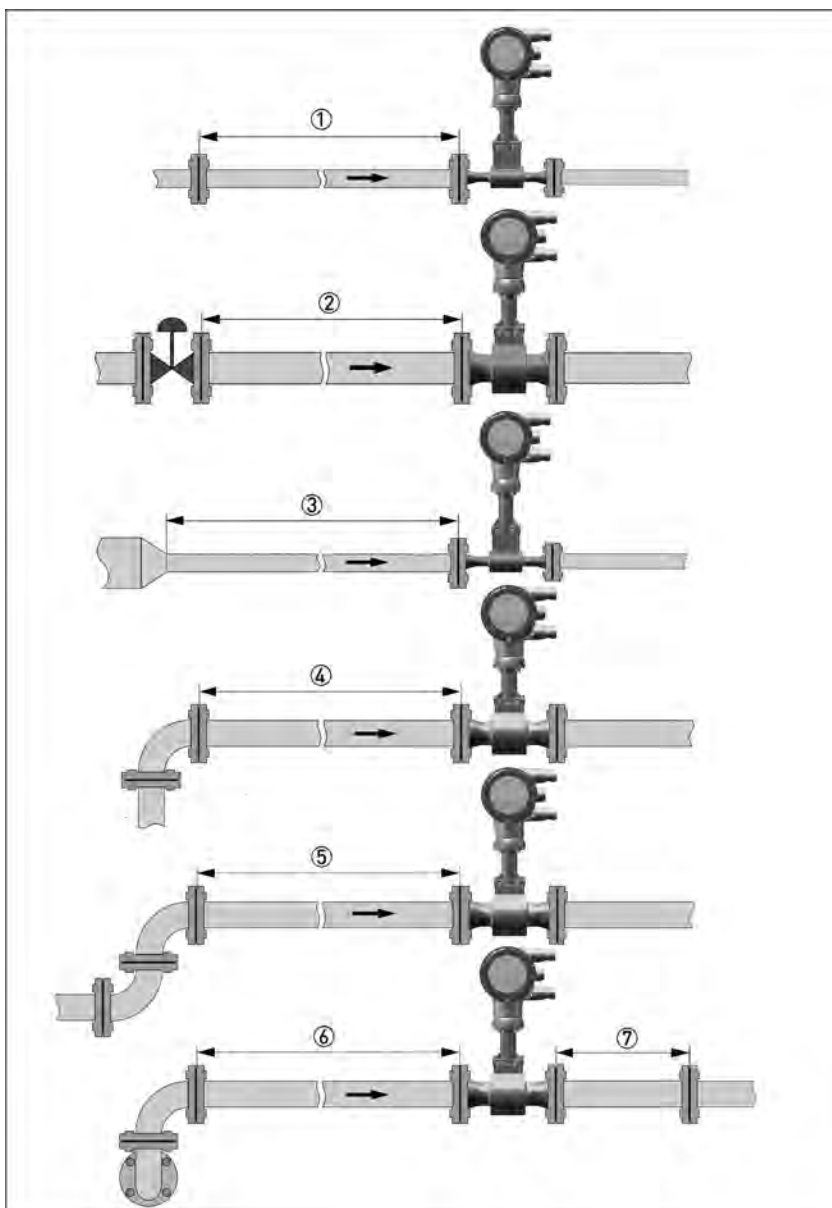

Figure 2-8: Inlet sections

- ① General inlet section without disturbing flow ≥ 15 DN
- ② Behind a control valve ≥ 50 DN
- ③ After a pipe diameter reduction ≥ 20 DN
- ④ After a single bend $90^\circ \geq 20$ DN
- ⑤ After a double bend $2 \times 90^\circ \geq 30$ DN
- ⑥ After a double three-dimensional bend $2 \times 90^\circ \geq 40$ DN
- ⑦ Outlet section: > 5 DN

**INFORMATION!**

The nominal diameter of the flange is significant for the determination of the minimum inlet and outlet sections for the nominal diameter reduced versions of vortex flowmeter versions F1R and F2R.

2.7 Minimum outlet sections

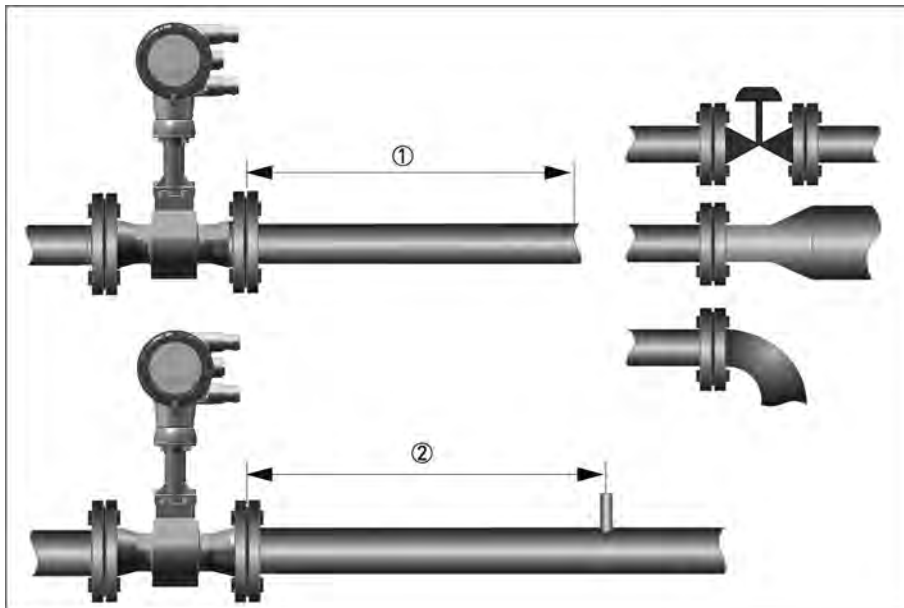

Figure 2-9: Minimum outlet sections

- ① Upstream of pipe expanders, pipe bends, control valves, etc. ≥ 5 DN
- ② Upstream of measuring points ≥ 5 DN



INFORMATION!

The interior of the pipe at the metering points must be free of burrs and other flow impediments. The measuring device has an internal temperature sensor. The distance from external temperature measuring points must be ≥ 5 DN. Use flow sensors that are as short as possible to avoid disturbances of the flow profile.

2.8 Flow straightener

If, due to the type of installation, the required inlet sections are not available, the manufacturer recommends using flow straighteners. Flow straighteners are installed between two flanges upstream of the device and shorten the required inlet section.

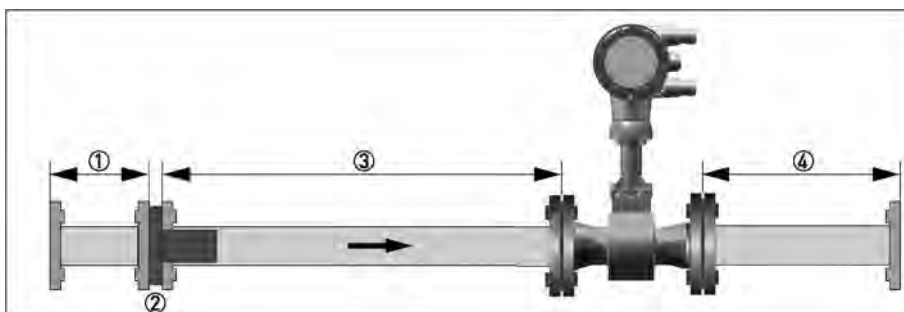

Figure 2-10: Flow straightener

- ① Straight inlet section upstream of straightener ≥ 2 DN
- ② Flow straightener
- ③ Straight pipe run between flow straightener and device ≥ 8 DN
- ④ Minimum straight outlet section ≥ 5 DN

2.9 Installation

2.9.1 General installation notes



CAUTION!

Installation, assembly, start-up and maintenance may only be performed by appropriately trained personnel. The regional occupational health and safety directives must always be observed.



The following procedures have to be carried out before installing the device:

- Ensure that the gaskets have the same diameter as the pipelines.
- Note the correct flow direction for the device. This is indicated by an arrow on the neck of the flow sensor.
- On measuring points with varying thermal loads, the devices have to be mounted with stress bolts (DIN 2510).
- Stress bolts or bolts and nuts are not included in the scope of delivery.
- Ensure that the measuring flange is concentrically fitted.
- Note the exact installation length of the measuring device when preparing the measuring point.

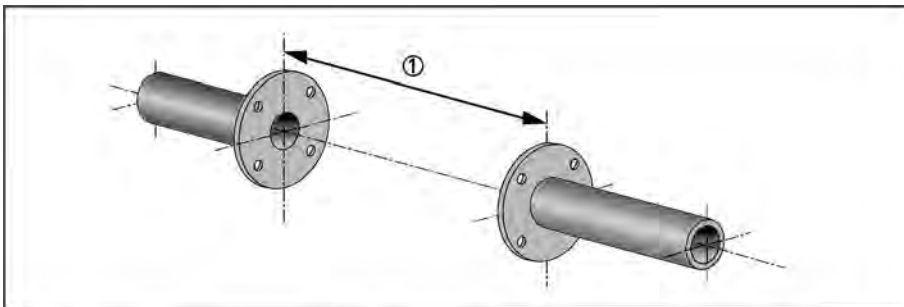

Figure 2-11: Preparing the metering point

- ① Installation length of measuring device + thickness of gaskets.



CAUTION!

The internal diameter of the pipelines, the flow sensor and the gaskets must match. The gaskets may not protrude into the flow.

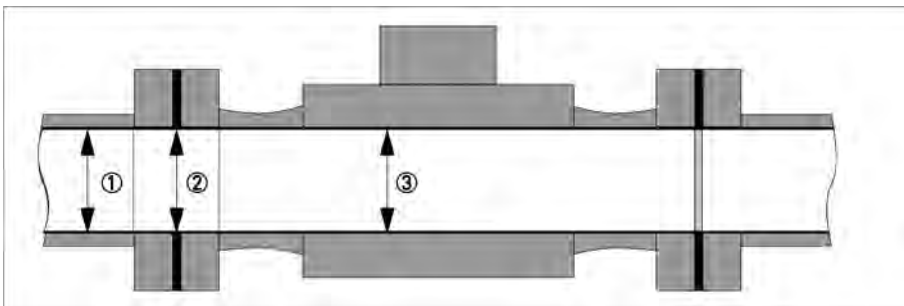

Figure 2-12: Inner diameter

- ① Inner diameter of connection pipe
 ② Inner diameter of flange and gasket
 ③ Inner diameter of flow sensor

2.9.2 Installing devices in sandwich design

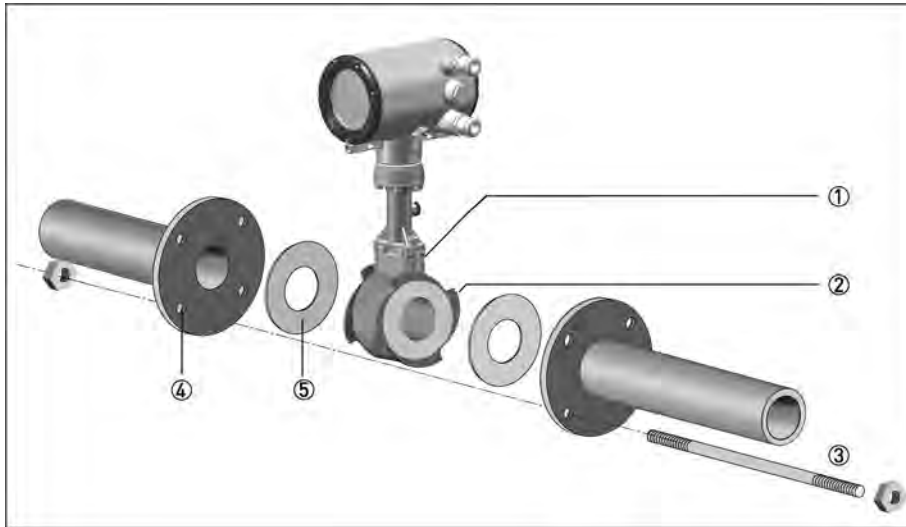

Figure 2-13: Installation using centering ring

- ① Flow sensor
- ② Centering ring
- ③ Bolts with fixing nuts
- ④ Drill hole
- ⑤ Sealing



- Push the first bolt ③ through the hole ④ of both flanges.
- Screw on the nuts and washers to both ends of the bolt ③ but do not tighten them.
- Install the second bolt through the holes ④.
- Place the flow sensor ① between the two flanges.
- Insert the gaskets ⑤ between flow sensor ① and flanges and align them.
- Check that the flange is concentric.
- Install the remaining bolts, washers and nuts. Do not yet tighten the nuts.
- Turn the centering ring ② in a counter-clockwise direction and align the device.
- Check that the gaskets ⑤ are concentric; they must not protrude into the pipe cross-section.
- Now tighten all nuts bit by bit alternately across the diagonal.

2.9.3 Installing devices in flange design

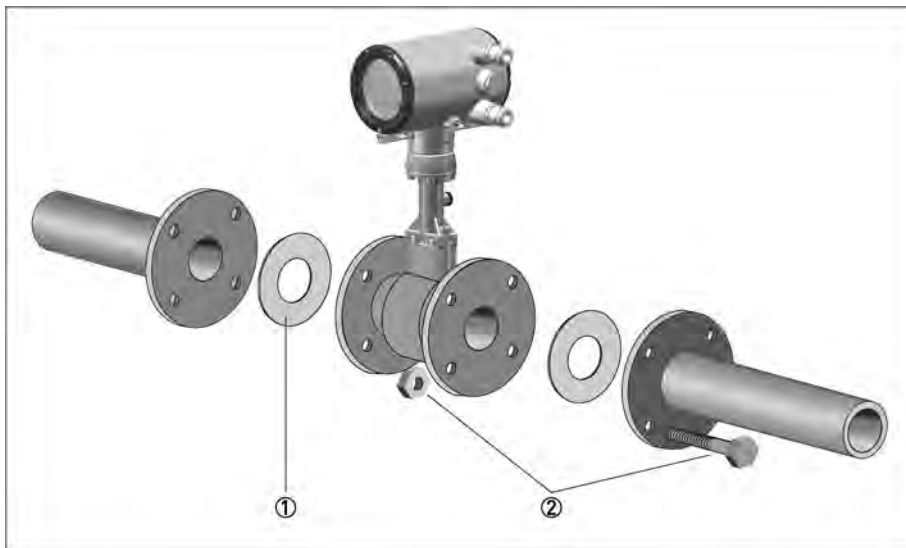

Figure 2-14: Installing devices in flange design

- ① Sealing
- ② Bolts with fastening nuts



- Use bolts and fastening nuts ② to attach the measuring device to one side of the flange.
- While doing so, insert the gaskets ① between flow sensor and flange and align them.
- Check that the gasket is concentric and that it is not protruding into the pipe cross-section.
- Install the gasket, bolts and fastening nuts on the other side of the flange.
- Align the measuring device and the gaskets so they are concentric.
- Now tighten all nuts bit by bit alternately across the diagonal.

2.9.4 Mounting the field housing, remote version



INFORMATION!

Assembly materials and tools are not part of the delivery. Use the assembly materials and tools in compliance with the applicable occupational health and safety directives.

Pipe mounting

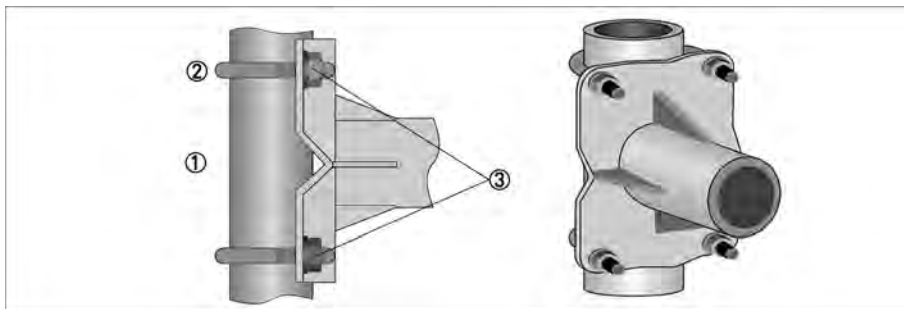

Figure 2-15: Pipe mounting of the field housing



- ① Fix the signal converter to the pipe.
- ② Fasten the signal converter using standard U-bolts and washers.
- ③ Tighten the nuts.

Wall mounting

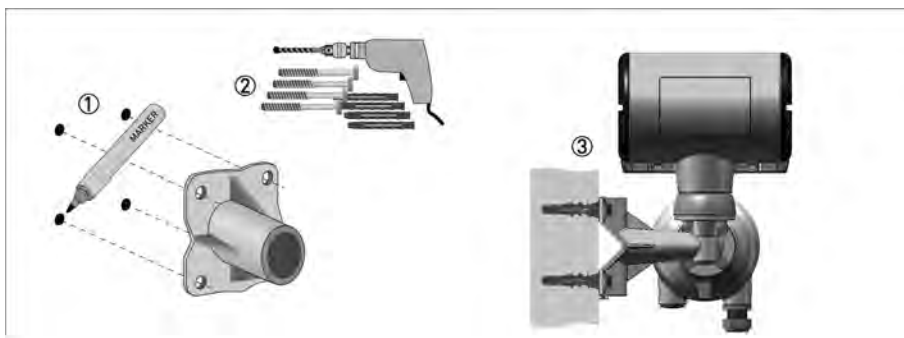

Figure 2-16: Wall mounting of the field housing



- ① Prepare the holes with the aid of the mounting plate.
- ② Use the mounting material and tools in compliance with the applicable occupational health and safety directives.
- ③ Fasten the housing securely to the wall.



INFORMATION!

Signal converters with a wall mounting rack have to be mounted with screws ($\varnothing 8$ mm / 0.3") or with U-brackets ($\varnothing 8$ mm / 0.3") in case of pole installation. In case of mounting directly to the wall, a mounting system with a minimum load force of 0.1 kN (for example FISCHER type UX10) suitable for the background has to be applied.

2.10 Heat insulation

**CAUTION!**

For applications with medium temperatures above +160°C / +320°F an insulation of the pipeline in accordance to the insulation guideline is suggested. Avoid higher electronic temperatures than +80°C / +176°F.

The area above the signal converter support must not be heat-insulated.

The heat insulation ③ may only extend to the maximum height ① shown below.

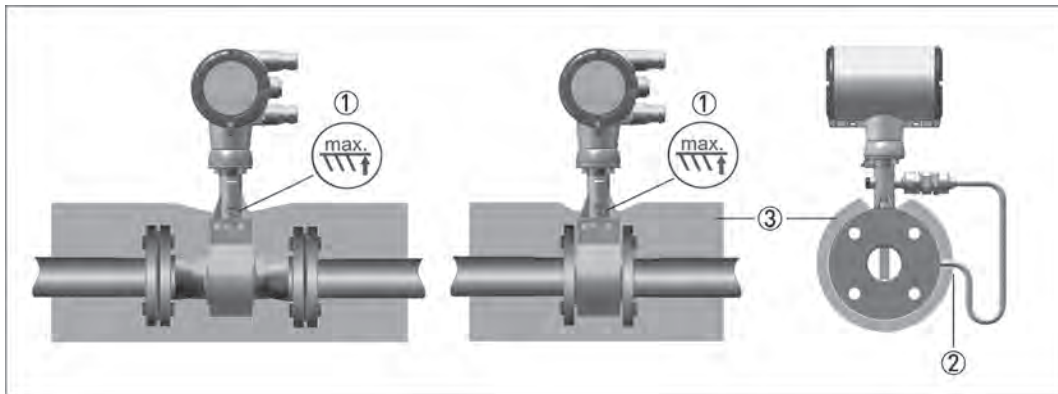

Figure 2-17: Installation heat insulation

- ① Max. height of the insulation up to the marking on the neck of the flow sensor
- ② Max. thickness of the insulation up to the bend of the pressure pipe
- ③ Insulation

**CAUTION!**

The heat insulation ③ may only extend as far as the bend of the pressure sensing line ②.

2.11 Turning the connection housing

**DANGER!**

All work on the device electronics may only be carried out by appropriately trained personnel.
The regional occupational health and safety directives must always be observed.

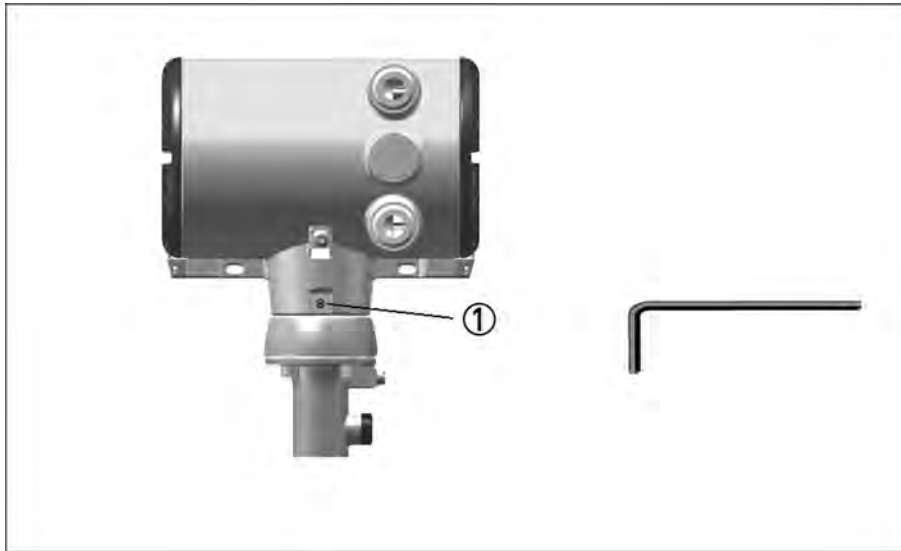

Figure 2-18: Turning the connection housing

① M4 Allen screw on connection housing



- Loosen the M4 Allen screw ① on the side of the connection housing.
- Rotate the connection housing to the desired position (0...360°).
- Tighten the M4 Allen screw ① again.

2.12 Turning the display

**DANGER!**

All work on the device electronics may only be carried out by appropriately trained personnel. The regional occupational health and safety directives must always be observed.

**INFORMATION!**

If the measuring device is installed in a vertical pipe, you will have to turn the display by 90°; if installed below a pipe, turn 180°.

**INFORMATION!**

The display can be turned in increments of 90° to four positions.

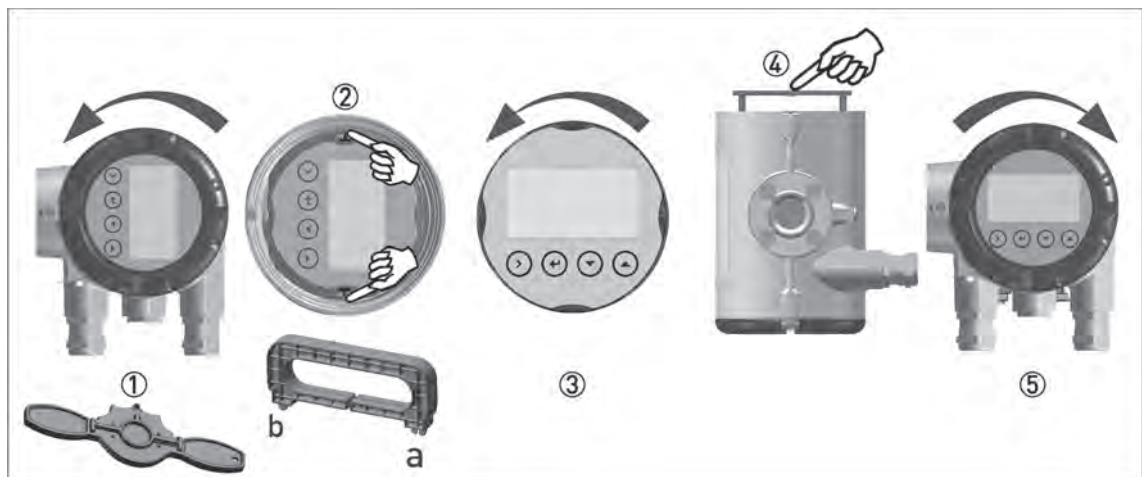

Figure 2-19: Turning the display

**Turn the display as follows:**

- Disconnect the power supply from the measuring device.
- Unscrew the housing cover with the key ①.
- Please use the handle to pull out the display module.
- First put the handle on side "a" and then on side "b" of the display, and then pull out the display ② carefully. Turn it into the favoured position ③.
- Disconnect the display from the handle first on side "a" and then on side "b".
- Press the display onto the spacer pins ④, until it clicks.
- Turn the cover with gasket ⑤ back onto the housing and tighten it by hand.

3.1 Safety instructions

**DANGER!**

All work on the electrical connections may only be carried out with the power disconnected. Take note of the voltage data on the nameplate.

**DANGER!**

Observe the national regulations for electrical installations!

**DANGER!**

For devices used in hazardous areas, additional safety notes apply; please refer to the Ex documentation.

**WARNING!**

Observe without fail the local occupational health and safety regulations. Any work done on the electrical components of the measuring device may only be carried out by properly trained specialists.

**INFORMATION!**

Check the device nameplate to ensure that the device is delivered according to your order. Check for the correct supply voltage printed on the nameplate.

3.2 Connecting the signal converter



DANGER!

All work on the electrical connections may only be carried out with the power disconnected. Take note of the voltage data on the nameplate!



INFORMATION!

When using the binary output M1...M4 as pulse output and frequencies above 100 Hz, shielded cables are to be used in order to reduce effects from electrical interferences (EMC).

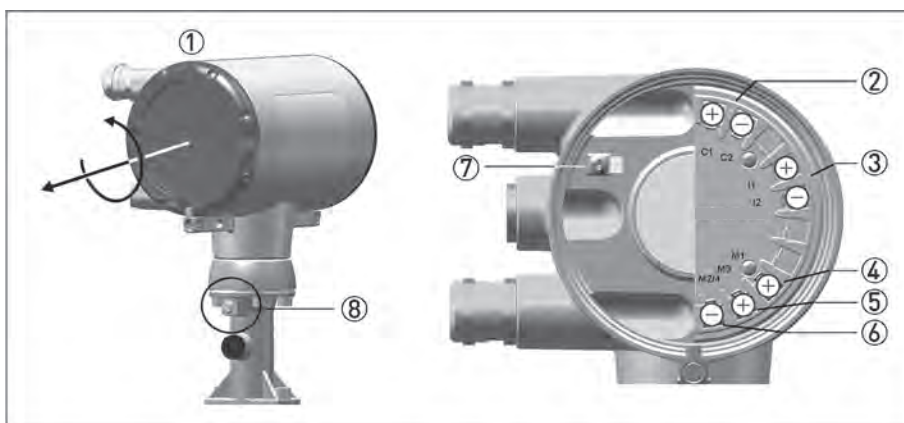

Figure 3-1: Connecting the signal converter

- ① Open the housing cover of the electrical terminal compartment using the key
- ② Signal converter supply and 4...20 mA loop
- ③ 4...20 mA current input, - external transmitter, optional
- ④ Terminal M1 binary (high current)
- ⑤ Terminal M3 binary (NAMUR)
- ⑥ Terminal M2/4 binary, common minus connection
- ⑦ Ground terminal in housing
- ⑧ Ground terminal on connection piece between flow sensor and signal converter



INFORMATION!

Both grounding terminals 7 and 8 are equally effective from a technical point of view.



Steps for connecting the signal converter:

- Unscrew the housing cover ① of the electrical terminal compartment.
- Feed the connection cable through the cable entry in the housing.
- Connect the cable according to the terminal diagrams below.
- Connect the grounding to the terminal ⑦. Alternatively use the ground terminal ⑧ on the connection piece between the flow sensor and the signal converter.
- Tighten the cable glands.
- Turn the housing cover and gasket back onto the housing and tighten it by hand.



INFORMATION!

Ensure that the housing gasket is properly fitted, clean and undamaged.

3.3 Electrical connections

The signal converter is a 2-wire device with 4...20 mA as output signal. All other inputs and outputs are passive and always require an additional power supply.

3.3.1 Power supply



INFORMATION!

The supply voltage has to be between 12 VDC and 36 VDC (12...30 VDC for Ex). This is based on the total resistance of the measuring loop. To calculate this, the resistance of each component in the measuring loop (not including the device) must be added up.

The required supply voltage can be calculated using the formula below:

$$U_{\text{ext.}} = R_L \cdot 22 \text{ mA} + 12 \text{ V}$$

with

$U_{\text{ext.}}$ = the minimum supply voltage

R_L = the total measuring loop resistance



INFORMATION!

The power supply has to be able to supply a minimum of 22 mA.

3.3.2 Current output

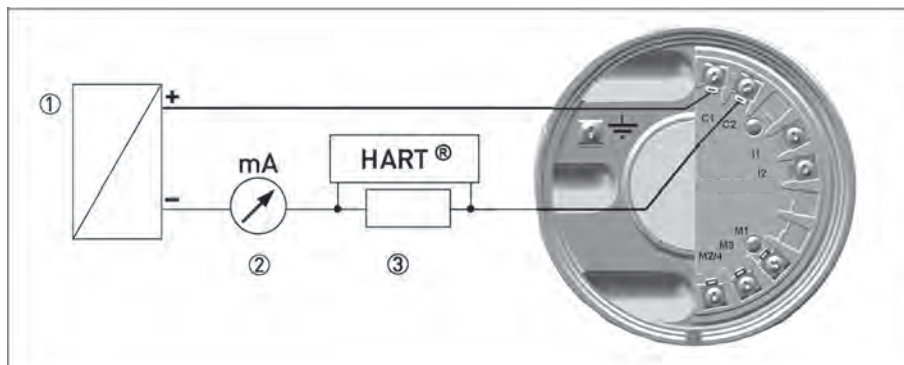

Figure 3-2: Electrical connection current output

- ① Power supply for current output
- ② Optional display unit (R_L)
- ③ Load for HART® $\geq 250 \Omega$

Connect current loop 4..20 mA to terminals C1+ and C2-.

When connection cables are long, a shielded or twisted cable may be necessary. The cable shield may only be grounded at one place (e.g. on the power supply unit).

3.3.3 Current input

An external transmitter, e.g. temperature or pressure transmitter, can be connected to terminals I1+ and I2-. The 4...20 mA current signal is converted to the corresponding temperature or pressure value in the signal converter.

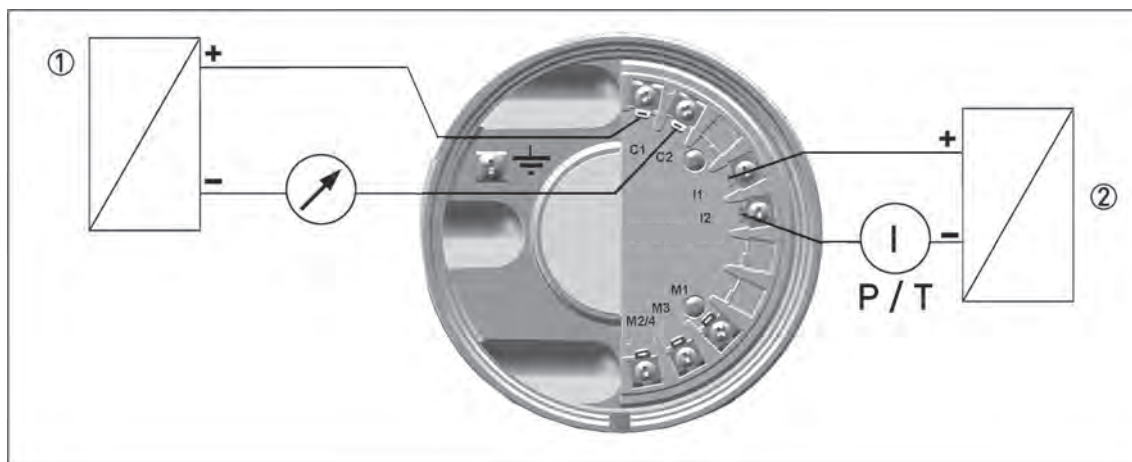

Figure 3-3: Electrical connection current input

- ① Power supply for the signal converter
- ② Current input of an external temperature or pressure transmitter

The current input can be configured in menu C1.5. Depending on the configuration of the current input, the sources for temperature and/or pressure value have to be adjusted in menu C1.6 or C1.7.

3.3.4 Binary output

Unless otherwise ordered, the binary output is inactive by default and must thus be activated and configured as limit switch output, pulse output, frequency output or status output in menu C2.2 prior to first use. The binary output is electrically separated from the current output and must be supplied with power separately.

3.3.5 Limit switch output

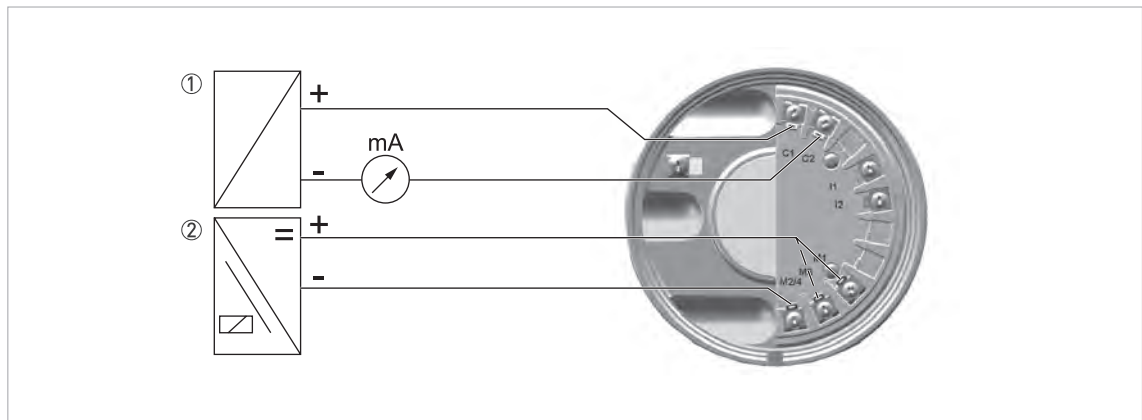

Figure 3-4: Connection binary output

- ① Power supply U_{ext} .
- ② Isolated switching amplifier



INFORMATION!

Binary output Mx can only be operated if the loop supply 4...20 mA is applied to the terminals C1+ and C2-. The binary output is inactive by default and must thus be activated in menu C2.2 prior to first use.

Connection binary output

In accordance with the desired signal transmission, select one of the following connection types for binary output M:

- M2/4 and M3 - NAMUR (DC interface in accordance with EN 60947-5-6)
- M2/4 and M1 - Transistor output (passive, open collector)

Terminal connection

Terminal	M1	M3	M2/4
Connection NAMUR		+ (open collector, $R_i \sim 1 \text{ k}\Omega$)	Common
Connection transistor output	+ (open collector, $I_{max} < 100 \text{ mA}$)		Common

Value range for NAMUR

	NC contact ①	NO contact ②
Switching value reached	< 1 mA	> 3 mA
Switching value not reached	> 3 mA	< 1 mA

① C2.2.6 Invert Signal On

② C2.2.6 Invert Signal Off

Value range applies only when connected to a switching amplifier with the following reference values:

- Open-circuit voltage $U_0 = 8.2$ VDC- Internal resistance $R_i = 1$ k Ω

Value range for transistor output

	U_L	I_L	U_H	I_H
via load R_L	0...2 V	0...2 mA	16...30 V	20...100 mA

To ensure the value ranges, a load R_L between 250 Ω and 1 k Ω is recommended for the passive transistor output with a nominal voltage of 24 VDC. If other loads are used, caution is advised as the range of values of the signal voltages then no longer corresponds to the range of values for the inputs of process control systems and controls (DIN IEC 946).

**CAUTION!**

The upper limit of the signal current must not be exceeded as this may damage the transistor output.

For selection of measurement variable and adjustable data of the limit switch refer to chapter "Menu description C - Setup", menu "C2.2.5 Limit Switch" and appropriate submenus.

3.3.6 Pulse output / Frequency output

The maximum frequency of both pulse output and frequency output is 1000 Hz.

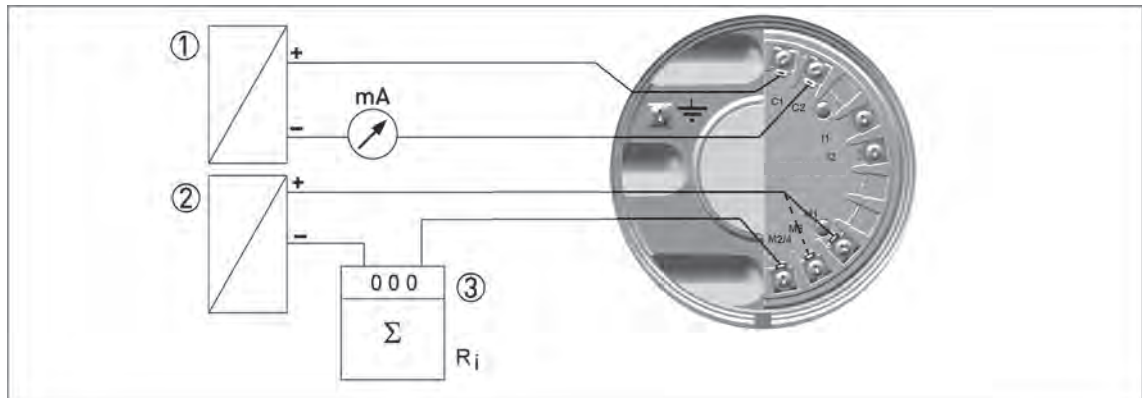

Figure 3-5: Electrical connection pulse output

- ① Signal converter power supply
- ② Pulse output power supply
- ③ Pulse counter or frequency meter

The connection is made between terminal M2/4 Common (-) and M1 for Hi Current (+) or M3 NAMUR (+). Only one of the two connections M1 or M3 can be selected in menu C2.2. The output is selected as pulse or frequency output in menu C2.2. The output is a passive "open collector" output which is electrically separated from the current interface and the flow sensor. It requires its own power supply ②. The total resistance must be adapted so that the total current I_{tot} does not exceed 120 mA.

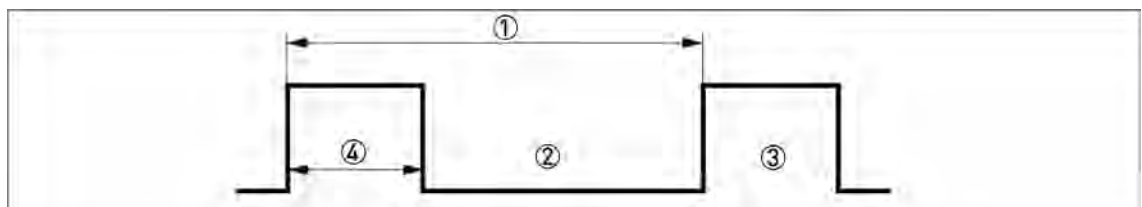

Figure 3-6: Pulse output signal definition

- ① T_{max}
- ② Closed
- ③ Open
- ④ Pulse width ≥ 0.5 ms

For selection of measurement variable and adjustable data of the pulse or frequency output refer to chapter "Menu description C - Setup", menu "C2.2.2 Pulse Output" or menu "C2.2.3 Frequency Output" and appropriate submenus.



INFORMATION!

Make sure the pulse width is in line with the pulse rate.

3.3.7 Status output

The + pole of the high current output is on the M1 terminal connection. The + pole of the NAMUR output is on the M3 connection terminal. Terminal M2/4 is the common - pole of the status output.

High current terminal M1...M2/4		
Open	Maximum voltage $U_{\max} = 36 \text{ VDC}$	Closed current $I_R < 1 \text{ mA}$
Closed	Maximum current $I_{\max} = 100 \text{ mA}$	Voltage $U < 2 \text{ VDC}$

NAMUR terminal M3...M2/4	
$R_T = 900 \Omega$	$U_{\max} = 36 \text{ VDC}$

For selection of status function and adjustable data of the status output refer to chapter "Menu description C - Setup", menu "C2.2.4 Status Output" and appropriate submenus.

3.4 Connection of remote version

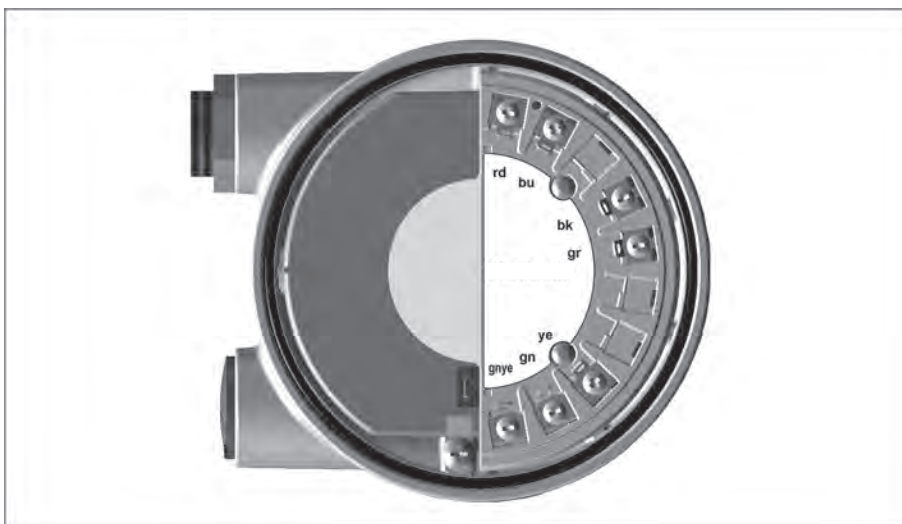

The connection terminals in the connection box of the flow sensor and the wall bracket are identical in construction.

Connection cable strand colour

Terminals	Strand colour
rd	red
bu	blue
bk	black
gr	grey
ye	yellow
gn	green
gnye	Shielding

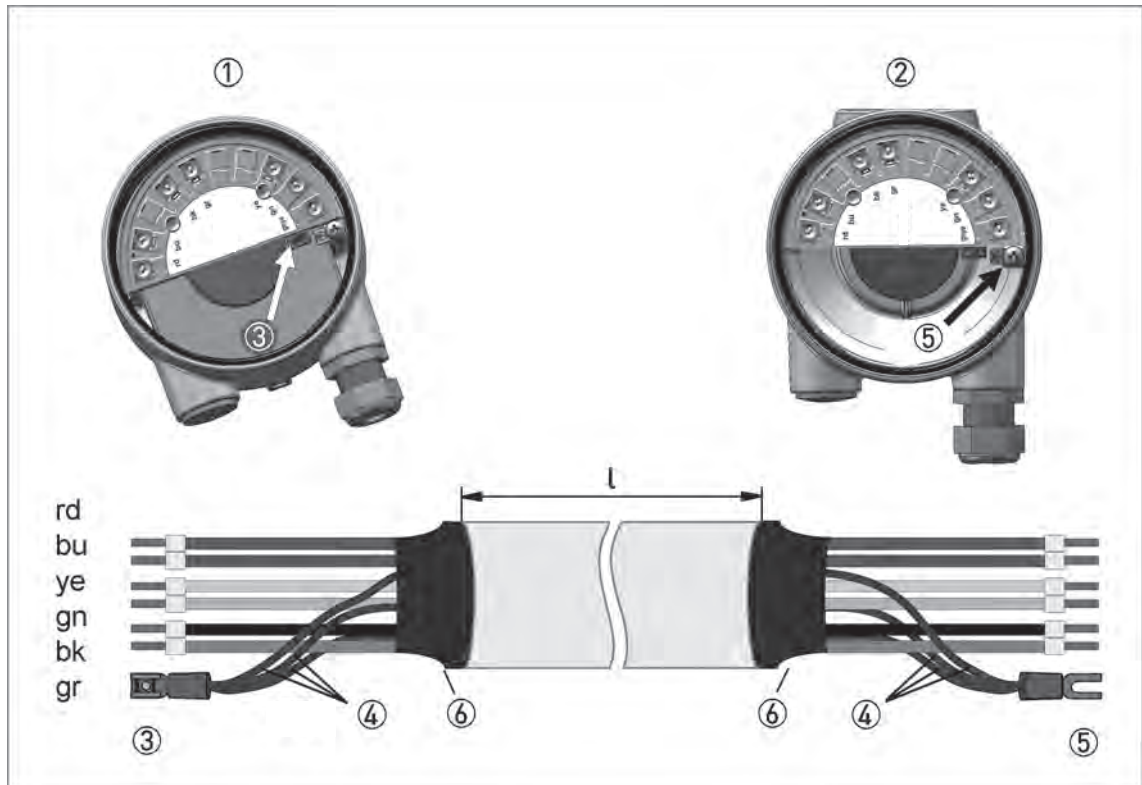

Figure 3-7: Connection of remote version

- ① Terminal connection of flow sensor
- ② Terminal connection of signal converter
- ③ Terminal end pair shielding of flow sensor
- ④ Filler wire pair shielding (protected with heat shrink tubing)
- ⑤ Fork clamp pair shielding on signal converter side
- ⑥ Heat shrink tubing

The maximum cable length is 50 m / 164 ft.

The cable can be shortened easily. All wires must be connected afterwards.



CAUTION!

Please ensure that the shielding ④ has been properly connected to both terminals ③ and ⑤. The exterior shielding of the cable must not be connected to any terminal.

3.5 Grounding connections

The grounding can be done either by connecting the PE (Protective Earth) terminal in the housing or the PE terminal on the connection piece between flow sensor and signal converter. Both of these electrical connections are equally effective from a technical point of view.

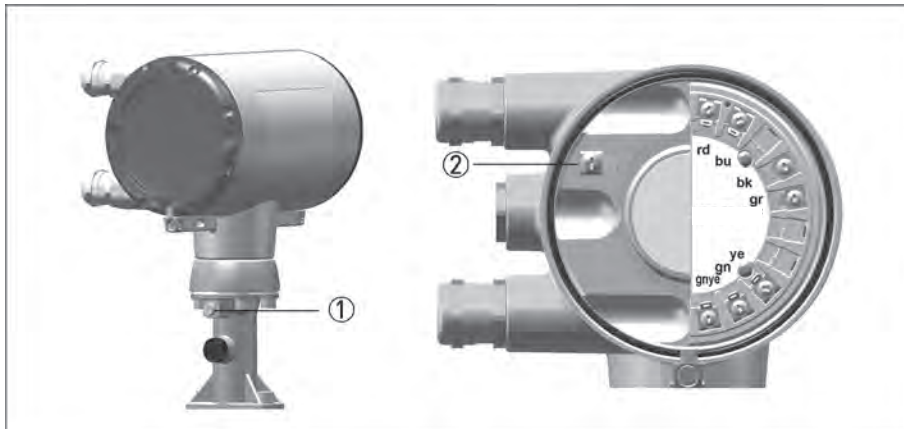

Figure 3-8: Ground connection compact version

- ① Electrical grounding connection on connection piece between flow sensor and signal converter.
- ② Electrical grounding terminal in the housing



CAUTION!

The measuring device has to be grounded properly to achieve accurate measurement. The grounding wire may not transfer any interference voltage. Do not use this grounding cable to ground any other electrical devices.

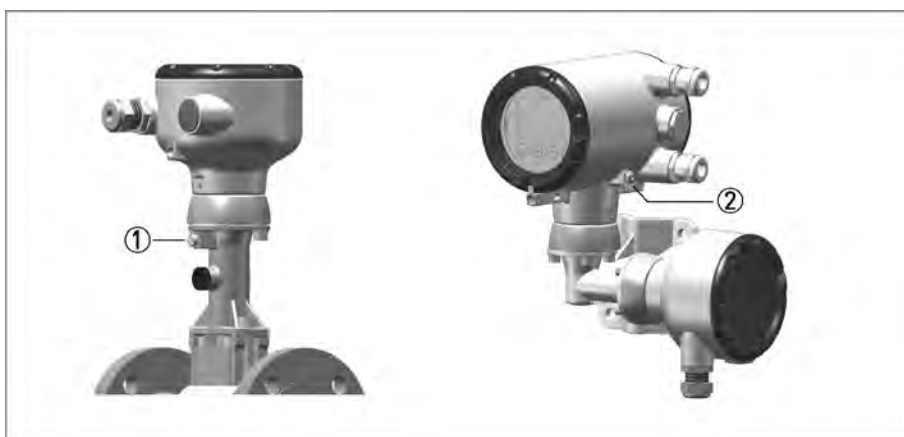

Figure 3-9: Ground connection remote version

- ① Electrical grounding connection on flow sensor
- ② Electrical grounding connection on signal converter housing



INFORMATION!

In the remote version, the flow sensor as well as the signal converter must be grounded.

3.6 Ingress protection

The signal converter electronics housing meets the requirements for IP66/67 in accordance with EN 60529 both for the compact and for the remote version.



CAUTION!

After all servicing and maintenance work on the measuring device, the specified ingress protection category must be ensured again.

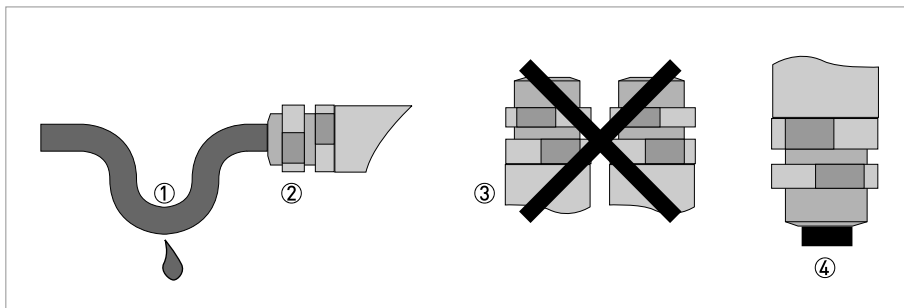

Figure 3-10: Cable feedthrough



Therefore it is essential to observe the following points:

- Use only original gaskets. They must be clean and free of any damage. Defective gaskets must be replaced.
- The electrical cables used must be undamaged and must comply with regulations.
- The cables must be laid with a loop ① upstream of the measuring device to prevent water from getting into the housing.
- The cable feedthroughs ② must be tightened. Note that the clamping range of the cable feedthrough corresponds to the outer diameter of the cable.
- Align the measuring device so that the cable feedthrough is never facing up ③.
- Close any unused cable feedthroughs using blind plugs ④ suitable for the protection category.
- Do not remove the required cable bushing from the cable feedthrough.



KROHNE – Process instrumentation and measurement solutions

- Flow
- Level
- Temperature
- Pressure
- Process Analysis
- Services

Head Office KROHNE Messtechnik GmbH
Ludwig-Krohne-Str. 5
47058 Duisburg (Germany)
Tel.: +49 203 301 0
Fax: +49 203 301 10389
info@krohne.com

The current list of all KROHNE contacts and addresses can be found at:
www.krohne.com

KROHNE