



OPTIFLEX 3200 C/F Technical Datasheet

Guided radar (TDR) level transmitter for liquids with hygienic requirements

- CIP/SIP-suitable hygienic design for level and interface measurement in small vessels
- Stainless steel housing, compact and remote
- Insensitive to steam, foam and condensation

HART
COMMUNICATION PROTOCOL



1	Product features	3
<hr/>		
1.1	The modular TDR level transmitter for liquids with hygienic requirements	3
1.2	Applications	4
1.3	Product family	5
1.4	Application table for probe selection	8
1.5	Measuring principle.....	8
2	Technical data	11
<hr/>		
2.1	Technical data.....	11
2.2	Minimum power supply voltage	19
2.3	Measurement limits	20
2.4	Dimensions and weights	22
3	Installation	28
<hr/>		
3.1	Intended use	28
3.2	How to prepare the tank before you install the device	28
3.2.1	General information for nozzles.....	28
3.3	Installation recommendations for liquids.....	29
3.3.1	General requirements	29
4	Electrical connections	30
<hr/>		
4.1	Electrical installation: 2-wire, loop-powered	30
4.1.1	Compact version	30
4.1.2	Remote version	31
4.2	Non-Ex devices	33
4.3	Devices for hazardous locations	35
4.4	Networks	35
4.4.1	General information.....	35
4.4.2	Point-to-point networks	35
4.4.3	Multi-drop networks	36
5	Order information	37
<hr/>		
5.1	Order code	37
6	Notes	41
<hr/>		

1.1 The modular TDR level transmitter for liquids with hygienic requirements

The OPTIFLEX 3200 is a TDR level transmitter designed for the measurement of level and interface in the food, beverage and pharmaceutical industries. The wetted parts have a gap-free hygienic design that ensures simple and reliable cleanability in processes that use CIP/SIP cleaning cycles.



- ① CIP/SIP-suitable hygienic design for level and interface measurement in small vessels
- ② Aluminium or stainless steel housing
- ③ Optional LCD screen with 4-button keypad
- ④ Quick coupling system: converter is rotatable and removable under process conditions

The display can be ordered with the device or as an accessory. It shows measurement data on a 128 × 64 pixel screen. The configuration menu permits the device to be set up in a small number of intuitive steps.

Highlights

- Process conditions up to +150°C / +302°F and 40 barg / 580 psig
- 2-wire 4...20 mA (HART® 7) with optional second output (current or switch/relay)
- ±2 mm / ±0.08" accuracy
- Measuring distances up to 4 m / 13.12 ft; level and interface measurement
- Can measure interface when the top product has a depth of only 50 mm / 1.97"
- SIL 2/3-compliant: 1 current output, 2 current outputs, or 1 current output + 1 switch output (relay)
- Quick Setup assistant for easy commissioning
- Display keypad directly accessible without opening the cover
- Real-time clock for event logging
- Diagnosis functions supply data according to NAMUR NE 107
- 3-year warranty

- Various converter and electronic versions to facilitate access to the device:
 - Remote converter up to 100 m / 328.08 ft from the probe
 - Horizontal or vertical housing to suit every installation
- PACTware™, HART® DD and DTM are provided free of charge with full functionality

Industries

- Food and beverage
- Pharmaceutical

Applications

Liquids with hygienic requirements at distances up to 4 m / 13.12 ft with temperature $\leq +150^{\circ}\text{C}$ / $+302^{\circ}\text{F}$ and pressure ≤ 40 barg / 580 psig. Typical products include fruit extract, fruit juice, yeast, beer, wine, milk, cheese, sauce, soup, vegetable oil, palm oil, chocolate, sugar, vaccines, plasma, purified water, aqueous solutions, alcohols, solvents, slightly corrosive acids, and alkalis.

1.2 Applications

1. Level measurement of liquids

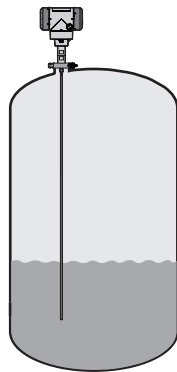

The level transmitter can measure the level of a wide range of liquid products on a large variety of installations within the stated pressure and temperature range. It does not require any calibration: it is only necessary to adapt the probe length and do a short configuration procedure.

2. Volume measurement

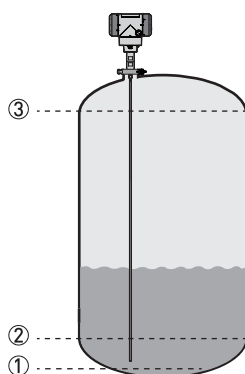

A conversion table (strapping table) function is available in the configuration menu for volume or mass measurement. Up to 30 volume values can be related to level values. For example:
 Level ①= 2 m / Volume ①= e.g. 0.7 m³
 Level ②= 10 m / Volume ②= e.g. 5 m³
 Level ③= 20 m / Volume ③= e.g. 17 m³

This data permits the device to calculate volumes between strapping table entries.

3. Measurement of liquids with a hygienic probe

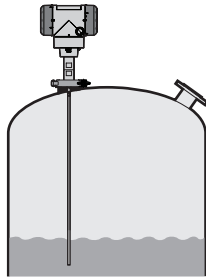

The hygienic probe option is made of materials that agree with FDA and European Union regulations. It is suitable for level measurement in processes that require hygienic equipment (such as the food, beverage and pharmaceutical industries). It is also suitable for CIP and SIP cycles.

1.3 Product family

OPTIFLEX 1100 C

for continuous measurement of liquids and solids up to 16 barg (232 psig) and +100°C (+212°F)



OPTIFLEX 1100 C is a 2-wire TDR level transmitter for measuring distance, level, volume and mass of liquids and solids. Its simple, compact design allows technicians to quickly assemble the probe and attach it to a threaded connection. It is an affordable solution for applications that do not require a high level of accuracy and is also an excellent alternative to traditional level controls such as RF Capacitance, conductive and DP transmitters.

It is ideal for level measurement in buffer tanks, collectors and simple process applications and silo level monitoring in quarrying and agriculture.

OPTIFLEX 3200 C/F**for liquids with hygienic requirements up to 40 barg (580 psig) and +150°C (+302°F)**

This TDR level transmitter, with its hygienic design, is ideal for measuring measure level and interface in small vessels and tanks with CIP/SIP cycles. It can also be installed in tanks up to 4 m / 13.12 ft high.

Probe options include:

- a single rod probe made of stainless steel with a surface roughness of $R_a < 0.76 \mu\text{m} / 30 \mu\text{in}$ – AARH, and
- a single rod probe and process connection that are entirely coated with PTFE (TFM-T62, FDA-approved)

OPTIFLEX 6200 C/F**for solids from granulates to powders up to 40 barg (580 psig) and +200°C (392°F)**

This level transmitter measures granulates and powders in deep pits or high containers. It has a maximum measuring distance of 40 m / 131.2 ft.

Its durable design can withstand traction loads up to 3500 kg (7700 lb) and electrostatic discharges up to 30 kV. A specially developed set of algorithms also permits the device to accurately measure the level of low-reflective media.

OPTIFLEX 7200 C/F/S/D**for liquids in storage and process applications up to 100 barg (1450 psig) and 250°C (482°F)**

The OPTIFLEX 7200 is designed specifically for measuring level and interface in the chemical, oil and gas industries. It can be used in high tanks (max. height 60 m / 197 ft) and pressure vessels.

It has many probe options, making it suitable for a wide range of process conditions. It can also measure volatile products such as carbon disulphide using the reversed interface probe.

The device's software also permits the device to accurately measure the level of products in processes where the composition of the gas above the product can change suddenly. This uses a patented algorithm called "Dynamic Gas-phase Compensation" (DGC).

OPTIFLEX 8200 C/F/S**for liquids at high temperature and pressure up to 320 barg (4641 psig) and 315°C (599°F)**

This level transmitter is designed specifically for measuring level and interface in extreme conditions such as boilers in the power, oil and gas industries.

It can be used in very high tanks (max. height 60 m / 197 ft). It can be equipped with a stainless steel housing for corrosive environments.

The device's software also permits the device to accurately measure the level of products in processes where the composition of the gas above the product can change suddenly. This uses a patented algorithm called "Dynamic Gas-phase Compensation" (DGC).

1.4 Application table for probe selection

	Single rod, hygienic	Single rod (PTFE-coated)
--	----------------------	--------------------------

Maximum probe length, L

4 m / 13 ft		
-------------	--	--

Liquids

Highly viscous liquids		
Highly crystallising liquids		
Foam		
Agitated liquids		
Storage tanks		
Hygienic applications		
Small diameter nozzles and long nozzles		
Stilling wells		

■ standard ■ optional □ on request

1.5 Measuring principle

This Guided Radar (TDR) level meter has been developed from a proven technology called Time Domain Reflectometry (TDR).

The device transmits low-intensity electromagnetic pulses of approximately one nanosecond width along a rigid or flexible conductor. These pulses move at the speed of light. When the pulses reach the surface of the product to be measured, the pulses are reflected with an intensity that depends on the dielectric constant, ϵ_r , of the product (for example, water has a high dielectric constant and reflects the pulse back to the signal converter at 80% of its original intensity).

The device measures the time from when the pulse is emitted to when it is received: half of this time is equivalent to the distance from the reference point of the device (the flange facing) to the surface of the product. The time value is converted into an output current of 4...20 mA and/or a digital signal.

Dust, foam, vapor, agitated surfaces, boiling surfaces, changes in pressure, changes in temperature and changes in density do not have an effect on device performance.

The illustration that follows shows a snapshot of what a user would see on an oscilloscope, if the level of one product is measured.

Level measurement principle (direct mode)

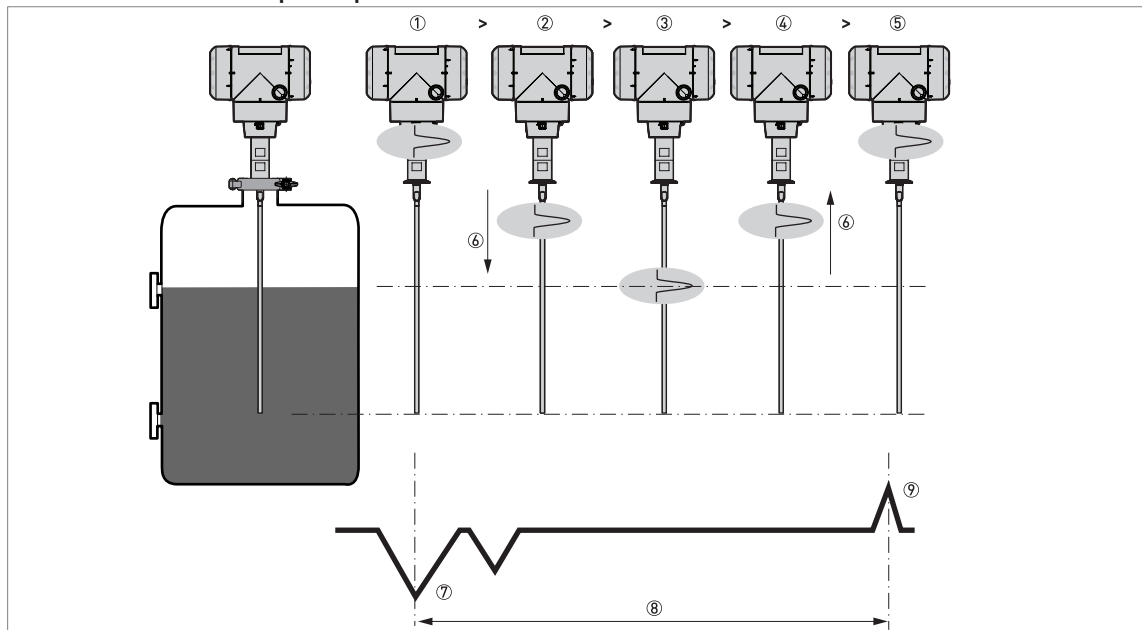

Figure 1-1: Level measurement principle

- ① Time 0: The electromagnetic (EM) pulse is transmitted by the converter
- ② Time 1: The pulse goes down the probe at the speed of light in air, V_1
- ③ Time 2: The pulse is reflected
- ④ Time 3: The pulse goes up the probe at speed, V_1
- ⑤ Time 4: The converter receives the pulse and records the signal
- ⑥ The EM pulse moves at speed, V_1
- ⑦ Transmitted EM pulse
- ⑧ Half of this time is equivalent to the distance from the reference point of the device (the flange facing) to the surface of the product
- ⑨ Received EM pulse

Level and interface measurement principle (direct measurement)

The illustration that follows shows a snapshot of what a user would see on an oscilloscope, if the level and/or interface of products are measured.

The dielectric constant of the top liquid must be less than the dielectric constant of the bottom liquid. If not, or if there is too small a difference, the device may not measure correctly.

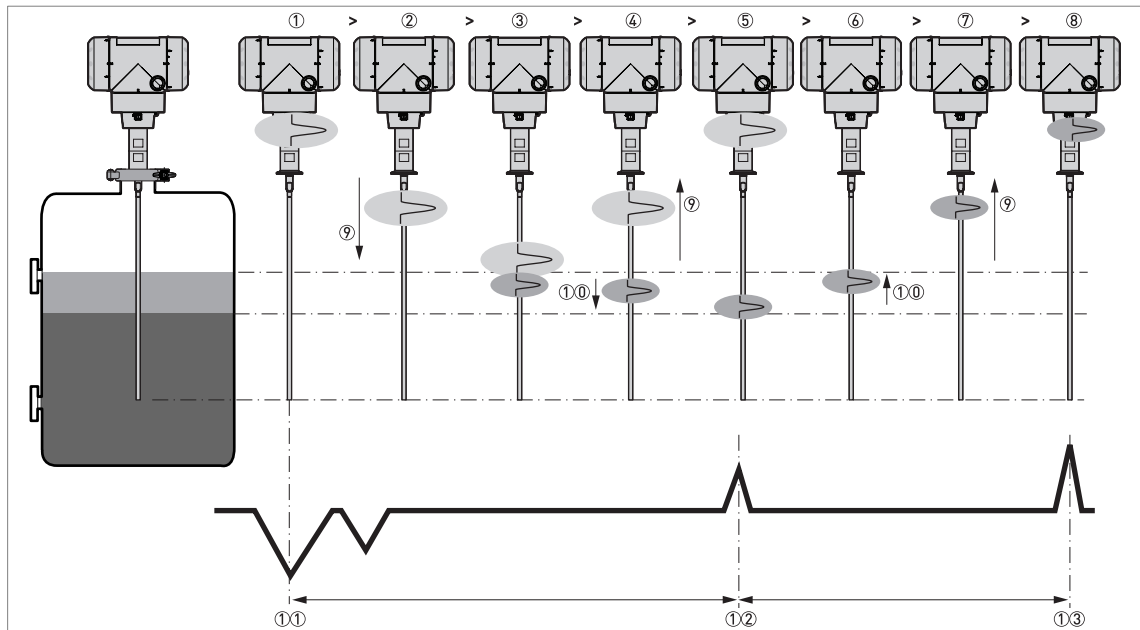

Figure 1-2: Level and interface measurement principle (2 liquids in the tank)

- ① Time 0: The electromagnetic (EM) pulse is transmitted by the converter
- ② Time 1: The pulse goes down the probe at the speed of light in air, V1
- ③ Time 2: Part of the pulse is reflected at the surface of the top liquid, the remaining pulse goes down the probe
- ④ Time 3: Part of the pulse goes up the probe at speed, V1. The remaining pulse goes down the probe at the speed of light in the top product, V2
- ⑤ Time 4: The converter receives part of the pulse and records the signal. The remaining pulse is reflected at the interface of the 2 liquids
- ⑥ Time 5: The remaining pulse goes up the probe at speed, V2
- ⑦ Time 6: The remaining pulse goes up the probe at speed, V1
- ⑧ Time 7: The converter receives the remaining pulse and records the signal
- ⑨ The EM pulse moves at speed, V1
- ⑩ The EM pulse moves at speed, V2
- ①① Transmitted EM pulse
- ①② Received EM pulse (distance to the top liquid)
- ①③ Received EM pulse (distance to the interface of 2 liquids)

Level measurement principle (TBF measurement)

If products have a very low dielectric constant ($\epsilon_r < 1.6$), only a small part of the EM pulse is reflected at the surface of the product. Most of the pulse is reflected at the probe end. TBF (tank bottom following) mode is used to measure the distance to the product surface.

TBF mode (indirect measurement) compares:

- The time for the pulse to go to the probe end and go back to the converter when the tank is empty.
- The time for the pulse to go to the probe end and go back to the converter when the tank is full or partially filled.

The level of the product in the tank can be calculated from the time difference.

2.1 Technical data

- The following data is provided for general applications. If you require data that is more relevant to your specific application, please contact us or your local sales office.
- Additional information (certificates, special tools, software,...) and complete product documentation can be downloaded free of charge from the website (Downloadcenter).

Converter

Measuring system

Application	Level and interface measurement of liquids and pastes
Measuring principle	TDR (time domain reflectometry)
Primary measured value	Distance and interface distance
Secondary values	Level, interface level, volume and mass
Construction	Compact (C) version: Measuring probe attached directly to a signal converter Remote (F) version: Measuring probe installed on a tank and connected by a signal cable (max. length 100 m / 328 ft) to a signal converter

Operating conditions

Ambient temperature	-40...+80°C / -40...+176°F Integrated LCD display: -20...+60°C / -4...+140°F; if the ambient temperature is not in these limits, the display switches off. The device continues to operate correctly.
Storage temperature	-50...+85°C / -58...+185°F (min. -40°C / -40°F for devices with the integrated LCD display option)
Ingress protection	IEC 60529: IP66 / IP68 (continuous immersion at a depth of 1.5 m for 2 weeks) NEMA 250: NEMA type 4X / 6 (housing) and type 6P (probe)

Materials

Housing	Polyester-coated aluminium or stainless steel (1.4404 / 316L)
Cable entry	Plastic; nickel-plated brass, stainless steel

Electrical connections

Power supply, output 1 (4...20 mA/HART output)	Non-Ex / Ex i: 11.5...30 V DC; min./max. value for an output of 22 mA at the terminals
	Ex d: 13.5...34 V DC; min./max. value for an output of 22 mA at the terminals
Power supply, optional output 2 (4...20 mA output)	Non-Ex / Ex i: 11.5...30 V DC; min./max. value for an output of 22 mA at the terminals (additional power supply needed – output only)
	Ex d: 11.5...34 V DC; min./max. value for an output of 22 mA at the terminals (additional power supply needed – output only)
Power supply, optional input 2 (switch output - relay)	Non-Ex / Ex d: 11.5...34 V DC / 30 mA
	Ex i: 11.5...30 V DC / 30 mA
Current output load	Non-Ex / Ex i: $R_L [\Omega] \leq ((U_{ext} - 11.5 V)/22 \text{ mA})$. For more data, refer to <i>Minimum power supply voltage</i> on page 19.
	Ex d, output 1: $R_L [\Omega] \leq ((U_{ext} - 13.5 V)/22 \text{ mA})$. For more data, refer to <i>Minimum power supply voltage</i> on page 19.
	Ex d, output 2: $R_L [\Omega] \leq ((U_{ext} - 11.5 V)/22 \text{ mA})$. For more data, refer to <i>Minimum power supply voltage</i> on page 19.

Cable entry	M20×1.5; ½ NPT
Cable gland	Standard: none
	Options: M20×1.5, others are available on request
	Cable diameter, output 1: non-Ex / Ex i: 6...7.5 mm / 0.24...0.30"; Ex d: 7...10 mm / 0.28...0.39"; Cable diameter, output 2: non-Ex / Ex i: 6...12 mm / 0.24...0.47"; Ex d: 7...12 mm / 0.28...0.47"
Signal cable – remote version	None for non-Ex devices (4-wire shielded cable of max. length 100 m / 328 ft to be supplied by the customer). Supplied with all Ex-approved devices. For more data, refer to the handbook
Cable entry capacity (terminal)	0.5...2.5 mm ²

Input and output

Measured variable	Time between the emitted and received signal
Current output / HART®	
Output 1 signal	4...20 mA HART® or 3.8...20.5 mA acc. to NAMUR NE 43 ①
Output 2 signal	4...20 mA or 3.8...20.5 mA acc. to NAMUR NE 43
Resolution	±3 µA
Temperature drift (analog)	Typically 50 ppm/K
Temperature drift (digital)	Max. ±15 mm for the full temperature range
Error signal options	High: 22 mA; Low: 3.6 mA acc. to NAMUR NE 43; Hold (frozen value – not available if the output agrees with NAMUR NE 43 or the device is approved for safety-related systems (SIL))
Switch output - relay (option)	
Description	Relay (1 contact, normally open). SIS 2 Sensitive Series (ELESTA GmbH).
Maximum switching capacity	48 V AC / 6 A; 24 V DC / 6 A [according to IEC 60947-5-1]
Voltage range	Non-Ex / Ex d: Category AC-1: 5...48 V AC / Category DC-1: 2...24 V DC
	Ex i: Category AC-1: 5...24 V AC / Category DC-1: 2...24 V DC
Current range	0.003...6 A
R _{on-state}	< 100 mΩ at 6 V / 100 mA
Switching capacity range	0.04...288 W (VA)

Display and user interface

User interface options	LCD display (128 × 64 pixels in 8-step greyscale with 4-button keypad)
Languages	English, German, French, Italian, Spanish, Portuguese, Japanese, Chinese (simplified), Russian, Czech, Polish and Turkish

Approvals and certification

CE	The device meets the essential requirements of the EU Directives. The manufacturer certifies successful testing of the product by applying the CE marking.
	For more data about the EU Directives and European Standards related to this device, refer to the EU Declaration of Conformity. You can download this document free of charge from the website (Download Center).
Vibration resistance	Housing: EN 60721-3-4, Category 4M4 (5...8.51 Hz: ±3.5 mm / 8.51...200 Hz: 1g; 15g shock ½sinus: 6 ms) Refer to "Probe options" in this section for the vibration resistance of probes
Conformity to sanitary regulations (wetted parts)	FDA 21 CFR 177.2600 and CFR 177.2415
	Regulation (EC) No 1935/2004, Commission Regulation (EC) No 2023/2006, Commission Regulation (EU) No 10/2011

Explosion protection	
ATEX (Ex ia, Ex ia/db or Ex ia/tb) EU Type Approval	Compact version
	II 1/2 G Ex ia IIC T6...T3 Ga/Gb;
	II 1/2 D Ex ia IIIC T85°C...T150°C Da/Db;
	or...
	II 1/2 G Ex ia/db IIC T6...T3 Ga/Gb;
	II 1/2 D Ex ia/tb IIIC T85°C...T150°C Da/Db
	Remote version, converter
	II 2 (1) G Ex ia [ia Ga] IIC T6...T4 Gb;
	II 2 (1) D Ex ia [ia Da] IIIC T85°C...T135°C Db
	or...
	II 2 (1) G Ex db ia [ia Ga] IIC T6...T4 Gb;
	II 2 (1) D Ex ia tb [ia Da] IIIC T85°C...T135°C Db
	Remote version, sensor
	II 1/2 G Ex ia IIC T6...T3 Ga/Gb;
II 1/2 D Ex ia IIIC T85°C...T150°C Da/Db	
ATEX (Ex ic or Ex ic nA) Type Approval	Compact version
	II 3 G Ex ic IIC T6...T3 Gc;
	II 3 D Ex ic IIIC T85°C...T150°C Dc
	or...
	II 3 G Ex ic nA IIC T6...T3 Gc
	Remote version, converter
	II 3 G Ex ic [ic] IIC T6...T4 Gc;
	II 3 D Ex ic [ic] IIIC T85°C...T135°C Dc
	or...
	II 3 G Ex ic nA [ic] IIC T6...T4 Gc
	Remote version, sensor
	II 3 G Ex ic IIC T6...T3 Gc;
	II 3 D Ex ic IIIC T85°C...T150°C Dc

IECEX	Compact version
	Ex ia IIC T6...T3 Ga/Gb;
	Ex ia IIIC T85°C...T150°C Da/Db
	or...
	Ex ia/db IIC T6...T3 Ga/Gb;
	Ex ia/tb IIIC T85°C...T150°C Da/Db
	or...
	Ex ic IIC T6...T3 Gc;
	Ex ic IIIC T85°C...T150°C Dc
	or...
	Ex ic nA IIC T6...T3 Gc
	Remote version, converter
	Ex ia [ia Ga] IIC T6...T4 Gb;
	Ex ia [ia Da] IIIC T85°C...T135°C Db
	or...
	Ex db ia [ia Ga] IIC T6...T4 Gb;
	Ex ia tb [ia Da] IIIC T85°C...T135°C Db
	or...
	Ex ic [ic] IIC T6...T4 Gc;
	Ex ic [ic] IIIC T85°C...T135°C Dc
	or...
	Ex ic nA [ic] IIC T6...T4 Gc
	Remote version, sensor
	Ex ia IIC T6...T3 Ga/Gb;
	Ex ia IIIC T85°C...T150°C Da/Db
	or...
Ex ic IIC T6...T3 Gc;	
Ex ic IIIC T85°C...T150°C Dc	

cQPSus – Dual Seal-approved	NEC 500 and CEC Section 18 and Annex J (Division ratings)
	Compact version
	IS, Class I, Div 1, GPS ABCD, T6...T3;
	IS, Class II/III, Div 1, GPS EFG, T85°C...T150°C
	or...
	XP-IS, Class I, Div 1, GPS A (US only) BCD, T6...T3;
	DIP-IS, Class II/III, Div 1, GPS EFG, T85°C...T150°C
	or...
	NI, Class I, Div 2, GPS ABCD, T6...T3;
	NI, Class II/III, Div 2, GPS FG, T85°C...T150°C
	Remote version, converter
	IS, Class I, Div 1, GPS ABCD, T6...T4;
	IS, Class II/III, Div 1, GPS EFG, T85°C...T135°C
	or...
	XP-IS, Class I, Div 1, GPS A (US only) BCD, T6...T4;
	DIP-IS, Class II/III, Div 1, GPS EFG, T85°C...T135°C
	or...
	NI, Class I, Div 2, GPS ABCD, T6...T4;
	NI, Class II/III, Div 2, GPS FG, T85°C...T135°C
	Remote version, sensor
	IS, Class I, Div 1, GPS ABCD, T6...T3;
	IS, Class II/III, Div 1, GPS EFG, T85°C...T150°C
	or...
	NI, Class I, Div 2, GPS ABCD, T6...T3;
NI, Class II/III, Div 2, GPS FG, T85°C...T150°C	
NEC 505 and NEC 506 (Zone ratings)	
Compact version	
Class I, Zone 0 AEx ia IIC T6...T3 Ga;	
Zone 20, AEx ia IIIC T85°C...T150°C Da	
or...	
Class I, Zone 1 AEx db ia [ia Ga] IIC T6...T3 Gb;	
Zone 21, AEx ia tb [ia Da] IIIC T85°C...T150°C Db	
Remote version, converter	
Class I, Zone 1 AEx ia [ia Ga] IIC T6...T4 Gb;	
Zone 21, AEx ia [ia Da] IIIC T85°C...T135°C Db	
or...	
Class I, Zone 1 AEx db ia [ia Ga] IIC T6...T4 Gb;	
Zone 21, AEx ia tb [ia Da] IIIC T85°C...T135°C Db	
Remote version, sensor	
Class I, Zone 0 AEx ia IIC T6...T3 Ga;	
Zone 20, AEx ia IIIC T85°C...T150°C Da	

	CEC Section 18 (Zone ratings)
	Compact version
	Ex ia IIC T6...T3 Ga;
	Ex ia IIIC T85°C...T150°C Da
	or...
	Ex db ia [ia Ga] IIC T6...T3 Gb;
	Ex ia tb [ia Da] IIIC T85°C...T150°C Db
	Remote version, converter
	Ex ia [ia Ga] IIC T6...T4 Gb;
	Ex ia [ia Da] IIIC T85°C...T135°C Db
	or...
	Ex db ia [ia Ga] IIC T6...T4 Gb;
	Ex ia tb [ia Da] IIIC T85°C...T135°C Db
	Remote version, sensor
	Ex ia IIC T6...T3 Ga;
	Ex ia IIIC T85°C...T150°C Da
NEPSI	Compact version
	Ex ia IIC T3~T6 Ga/Gb;
	Ex iaD 20/21 T85~T150
	or...
	Ex ia/d IIC T3~T6 Ga/Gb;
	Ex iaD 20 tD A21 IP6X T85°C~T150°C
	Remote version, converter
	Ex ia [ia Ga] IIC T4~T6 Gb;
	Ex iaD [iaD 20] 21 T85~T135
	or...
	Ex d ia [ia Ga] IIC T4~T6 Gb;
	Ex iaD 21 tD A21 [iaD 20] IP6X T85°C~T135°C
	Remote version, sensor
	Ex ia IIC T3~T6 Ga/Gb;
	Ex iaD 20/21 T85~T150

EAC-EX (pending)	Compact version	
	Ga/Gb Ex ia IIC T6...T3 X;	
	Da/Db Ex ia IIIC T85°C...T150°C X	
	or...	
	Ga/Gb Ex ia/db IIC T6...T3 X;	
	Da/Db Ex ia/tb IIIC T85°C...T150°C X	
	Remote version, converter	
	1Ex ia [ia Ga] IIC T6...T4 Gb X;	
	Ex ia [ia Da] IIIC T85°C...T135°C Db X	
	or...	
	1Ex db ia [ia Ga] IIC T6...T4 Gb X;	
	Ex ia tb [ia Da] IIIC T85°C...T135°C Db X	
	Remote version, sensor	
Ga/Gb Ex ia IIC T6...T3 X;		
Da/Db Ex ia IIIC T85°C...T150°C X		
Hygienic		
EHDG	For Tri-Clamp® and DIN 11851 process connections when fitted with an alternative gasket (which agrees with the latest edition of the EHEDG Position paper "Easy cleanable pipe couplings and process connections" - available on this website: https://www.ehedg.org/)	
Other standards and approvals		
SIL	C (Compact) version only: SIL 2/3 (SIL3: 1oo2 architecture is necessary for homogeneous redundancy) – certified according to all the requirements in EN 61508 (Full Assessment) and for high/low continuous demand mode operation. HFT=0, SFF=93% (for non-Ex / Ex i devices with one output), 94% (for non-Ex / Ex i devices with two outputs) or 95% (for Ex d devices), type B device	
EMC	Electromagnetic Compatibility (EMC) directive. The device agrees with this directive and its related standard if the device has a single probe that is installed in a metallic tank. SIL 2-approved devices agree with EN 61326-3-1 and EN 61326-3-2.	
NAMUR	NAMUR NE 21 Electromagnetic Compatibility (EMC) of Industrial Process and Laboratory Control Equipment	
	NAMUR NE 43 Standardization of the Signal Level for the Failure Information of Digital Transmitters	
	NAMUR NE 53 Software and Hardware of Field Devices and Signal Processing Devices with Digital Electronics	
	NAMUR NE 107 Self-Monitoring and Diagnosis of Field Devices	

① HART® is a registered trademark of the FieldComm Group™

Probe options

	Single rod Ø8 mm / 0.32"	Single rod Ø10 mm / 0.39" (fully TFM-T62 PTFE-coated)

Measuring system

Application	Liquids	
Measuring range	0.6...4 m / 1.97...13.12 ft	0.6...4 m / 1.97...13.12 ft
Dead zone	This depends on the type of probe. For more data., refer to <i>Measurement limits</i> on page 20	

	Single rod Ø8 mm / 0.32"	Single rod Ø10 mm / 0.39" (fully TFM-T62 PTFE-coated)
--	-----------------------------	---

Measuring accuracy

Accuracy (in direct mode)	Standard ±2 mm / ±0.08"
	Interface ±10 mm / ±0.4" (ϵ_r constant)
Accuracy (in TBF mode)	±20 mm / ±0.8"
Minimum layer (interface)	50 mm / 2"
Resolution	0.1 mm / 0.004"
Repeatability	±1 mm / ±0.04"
Maximum rate of change at 4 mA	100 m/min / 328 ft/min
Reference conditions acc. to EN 61298-1	
Temperature	+15...+25°C / +59...+77°F
Pressure	1013 mbara ±50 mbar / 14.69 psia ±0.73 psi
Relative air humidity	60% ±15%

Operating conditions

Min./Max. temperature at the process connection ①	-50...+150°C / -58...+302°F
Pressure	-1...40 barg / -14.5...580 psig
Viscosity (liquids only)	10000 mPa·s / 10000 cP
Dielectric constant	≥ 1.6 in direct mode (interface: $\epsilon_r(\text{interface}) \gg \epsilon_r(\text{level})^2$); ≥ 1.1 in TBF mode
Vibration resistance	EN 60721-3-4, Category 4M3 (5...8.22 Hz: ±0.75 mm / 8.22...200 Hz: 0.2g; 5g shock ½sinus: 6 ms)

Materials

Probe	Stainless steel (1.4404 / 316L)	TFM-T62 PTFE-coated stainless steel (1.4404 / 316L)
Gasket (process seal)	FKM/FPM (-40...+150°C / -40...+302°F); Kalrez® 6221 (-20...+150°C / -4...+302°F); EPDM (-50...+150°C / -58...+302°F) Also applicable to CIP and SIP cycles ②	None. TFM-T62 PTFE layer: (-50...+150°C / -4...+302°F)
Process connection	Stainless steel (1.4404 / 316L)	TFM-T62 PTFE-coated stainless steel (1.4404 / 316L)
Other wetted parts	PEEK Victrex 450G	PTFE
Surface roughness of metallic wetted parts	For hygienic applications only: Ra <0.76 µm	—

Process connections

Hygienic	For more data on options, refer to <i>Order code</i> on page 37
----------	---

① Also depends on the temperature limits of the gasket material. Refer to "Materials" in this table.

② Kalrez® is a registered trademark of DuPont Performance Elastomers L.L.C.

Process connection options: flange facing finish

Type (flange facing)	Flange facing finish, R_a (min...max)	
	[μm]	[$\mu\text{in} - \text{AARH}$]

ISO 2852 / DIN 32676 (Tri-Clamp®)

—	≤ 0.76	30
---	-------------	----

DIN 11851

—	≤ 0.76	30
---	-------------	----

SMS 1145

—	≤ 0.76	30
---	-------------	----

2.2 Minimum power supply voltage

Use these graphs to find the minimum power supply voltage for a given current output load.

Non-Ex and Hazardous Location approved (Ex i / IS / NI) devices

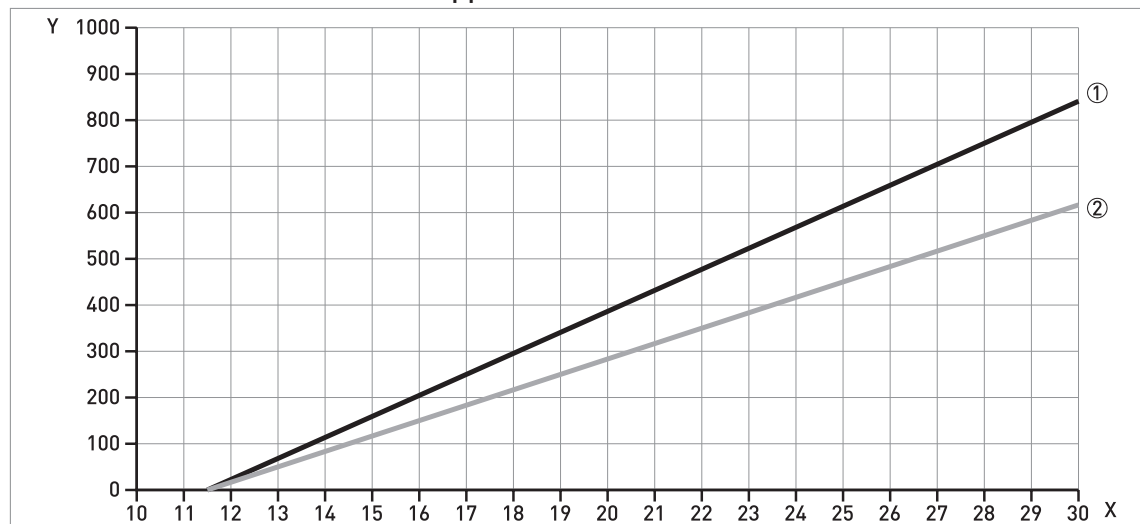

Figure 2-1: Non-Ex and Hazardous Location approval (Ex i / IS / NI): minimum power supply voltage for an output of 22 mA (switch output - relay option: 30 mA) at the terminals

X: Power supply U [V DC]

Y: Current output load R_L [Ω]

① Output 1: 4...20 mA/HART

Output 2: 4...20 mA (NOTE: use a separate power supply to energize output 2)

② Output 2: switch output - relay option

Hazardous Location (Ex d / XP/ DIP) approved devices

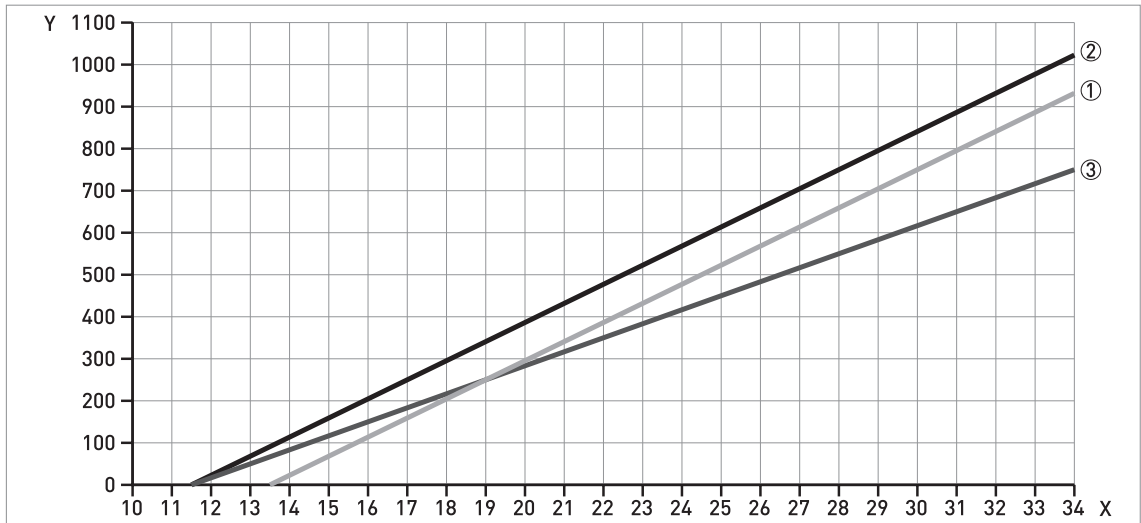

Figure 2-2: Non-Ex and Hazardous Location approval (Ex d / XP/ DIP): minimum power supply voltage for an output of 22 mA (switch output - relay option: 30 mA) at the terminals

X: Power supply U [V DC]

Y: Current output load R_L [Ω]

① Output 1: 4...20 mA/HART

② Output 2: 4...20 mA (NOTE: use a separate power supply to energize output 2)

③ Input 2: switch output - relay option

2.3 Measurement limits

Single rod probes

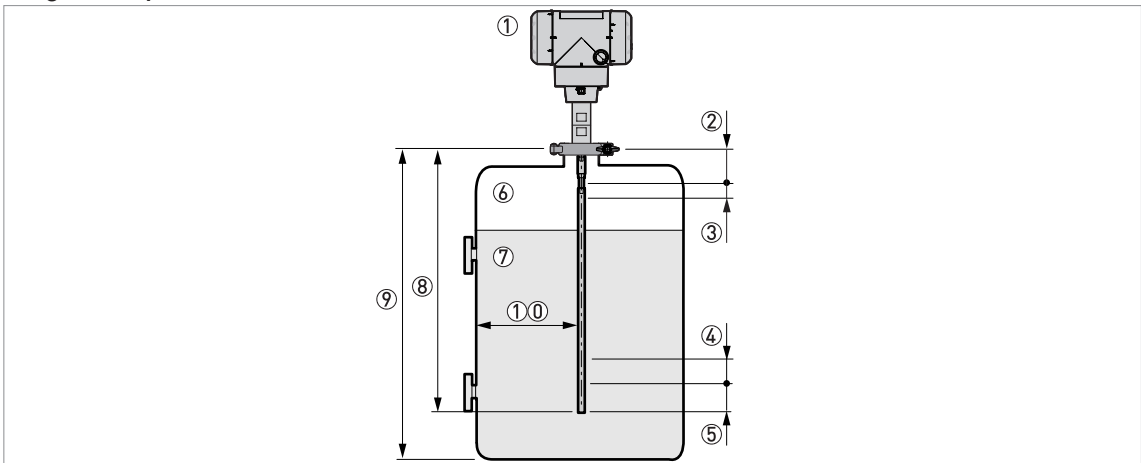

Figure 2-3: Measurement limits

① Device with a single rod probe

② **Top dead zone:** Top part of the probe where measurement is not possible

③ **Top non-linearity zone:** Top part of the probe with a lower accuracy of ± 30 mm / ± 1.18 "

④ **Bottom non-linearity zone:** Bottom part of the probe with a lower accuracy of ± 30 mm / ± 1.18 "

⑤ **Bottom dead zone:** Bottom part of the probe where measurement is not possible

⑥ Gas (Air)

⑦ Product

⑧ L, Probe length

⑨ Tank Height

⑩ **Minimum distance from the probe to a metallic tank wall:** 300 mm / 12"

Measurement limits (dead zone) in mm and inches

Probe	$\epsilon_r = 80$				$\epsilon_r = 2.5$			
	Top ②		Bottom ⑤		Top ②		Bottom ⑤	
	[mm]	[inches]	[mm]	[inches]	[mm]	[inches]	[mm]	[inches]
Ø8 mm / 0.32" single rod	50	1.97	20	0.79	50	1.97	60	2.36
Ø10 mm / 0.39" single rod (PTFE-coated)	50	1.97	20	0.79	50	1.97	60	2.36

Measurement limits (non-linearity zone) in mm and inches

Probe	$\epsilon_r = 80$				$\epsilon_r = 2.5$			
	Top ③		Bottom ④		Top ③		Bottom ④	
	[mm]	[inches]	[mm]	[inches]	[mm]	[inches]	[mm]	[inches]
Ø8 mm / 0.32" single rod	150	5.91	0	0	150	5.91	0	0
Ø10 mm / 0.39" single rod (PTFE-coated)	150	5.91	0	0	150	5.91	0	0

80 is ϵ_r of water; 2.5 is ϵ_r of oil

If you did the Auto Setup procedure after you installed the device, the values in the tables are correct. If you did not do the Auto Setup procedure, then the values for the dead zones and the non-linearity zones increase. If the cable probe does not have a counterweight, speak or write to your local supplier for more data.

The device software function "Blocking Distance" is set at the factory to 50 mm / 1.97", which is higher than or equal to the largest dead zone. This value agrees with the minimum dielectric constant at which the device can measure the level of a product. You can adjust "Blocking Distance" to agree with the dead zone (for this data, refer to the measurement limits table). For more data about the device software, refer to the handbook.

2.4 Dimensions and weights

All housing covers have bayonet connectors unless it is an explosion-proof (XP / Ex d-approved) device or has the second current output / switch output (relay) option. If the device has the second current output / switch output (relay) option or has an Ex d / XP (explosion-proof) approval, the terminal compartment cover has a thread with a flame path.

Overall dimensions

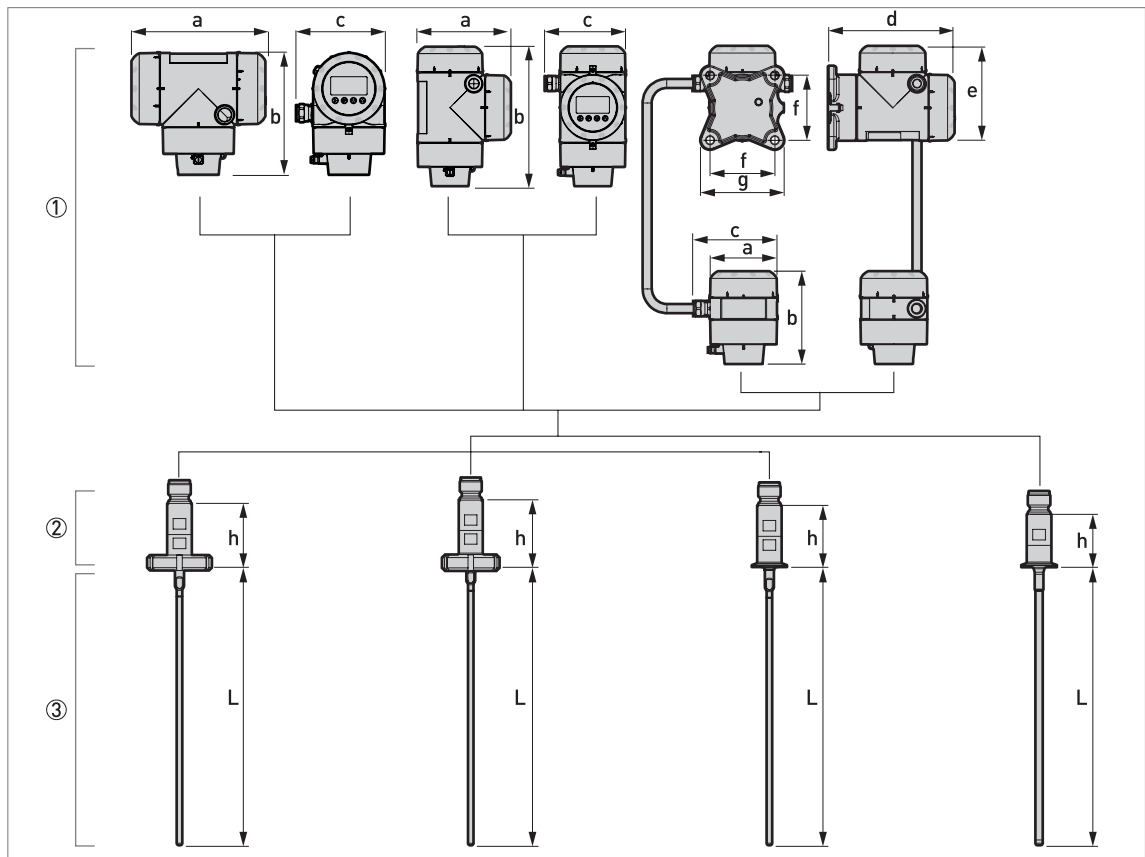

Figure 2-4: Overall dimensions

- ① **Housing options.** From left to right: compact converter with horizontal housing, compact converter with vertical housing, and remote converter (top) and probe electronics housing (bottom)
- ② **Process connection options.** From left to right:
 - DIN 11851 connection, SMS 1145 coupling and Tri-Clamp® for polished $\varnothing 8$ mm / 0.32" single rod probe;
 - Tri-Clamp® for $\varnothing 8$ mm / 0.32" single rod probe with PTFE coating
- ③ **Probe options.** From left to right:
 - Polished $\varnothing 8$ mm / 0.32" single rod probe, $\varnothing 10$ mm / 0.39" single rod probe with PTFE coating

Housing options: Dimensions in mm

Dimensions [mm]	Compact – horizontal		Compact – vertical		Remote	
	Non-Ex / Ex i / IS	Optional output / Ex d / XP	Non-Ex / Ex i / IS	Optional output / Ex d / XP	Non-Ex / Ex i / IS	Optional output / Ex d / XP
a	191	258	147	210	104	104
b	175	175	218	218	142	
c	127	127	127	127	129	129
d	—	—	—	—	195	195
e	—	—	—	—	146	209
f	—	—	—	—	100	100
g	—	—	—	—	130	130

Housing options: Dimensions in inches

Dimensions [inches]	Compact – horizontal		Compact – vertical		Remote	
	Non-Ex / Ex i / IS	Optional output / Ex d / XP	Non-Ex / Ex i / IS	Optional output / Ex d / XP	Non-Ex / Ex i / IS	Optional output / Ex d / XP
a	7.52	10.16	5.79	8.27	4.09	4.09
b	6.89	6.89	8.23	8.23	5.59	5.59
c	5.00	5.00	5.00	5.00	5.08	5.08
d	—	—	—	—	7.68	7.68
e	—	—	—	—	5.75	8.23
f	—	—	—	—	3.94	3.94
g	—	—	—	—	5.12	5.12

Process connection and probe options: Dimensions in mm

Dimensions [mm]	Polished Ø8 mm single rod probe			Ø8 mm single rod probe with PTFE coating
	DIN 11851	SMS 1145	Tri-Clamp®	Tri-Clamp®
h	88	88	88	75
L	For more data, refer to "Probe options" in this section.			

Process connection and probe options: Dimensions in inches

Dimensions [inches]	Polished Ø0.32" single rod probe			Ø0.32" single rod probe with PTFE coating
	DIN 11851	SMS 1145	Tri-Clamp®	Tri-Clamp®
h	3.46	3.46	3.46	2.95
L	For more data, refer to "Probe options" in this section.			

Weather protection option (vertical signal converters – for the compact version only)

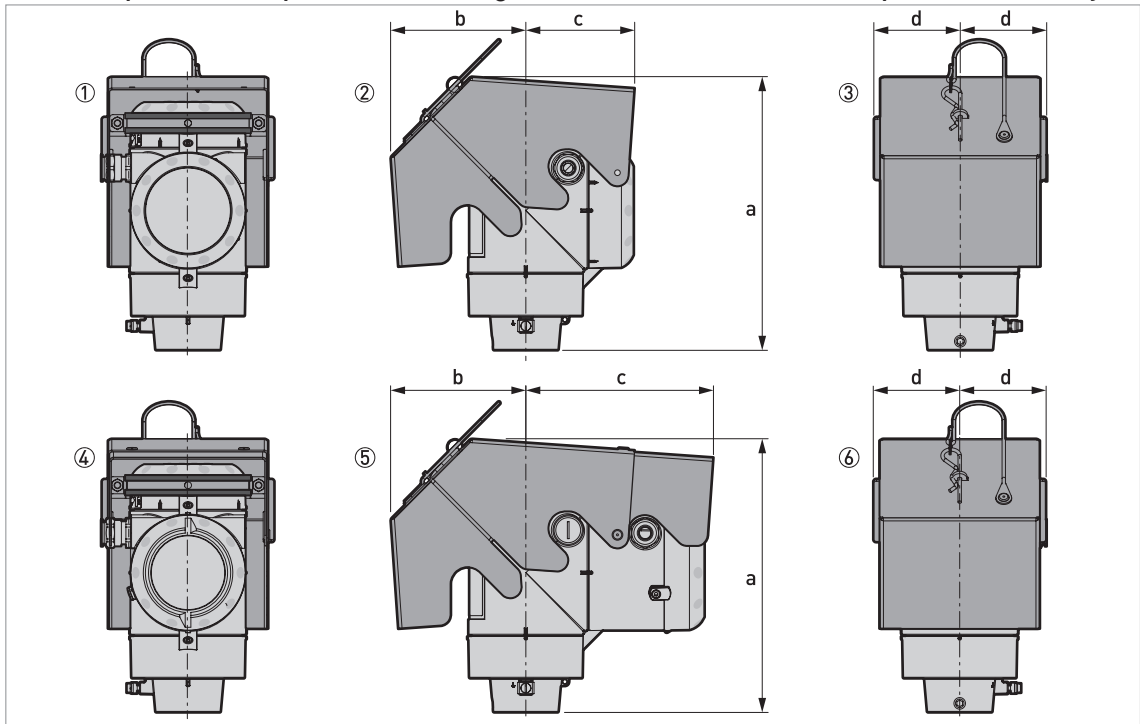

Figure 2-5: Weather protection option for vertical signal converter versions (compact version only)

- ① Non-Ex / Ex i / IS: Rear view (with weather protection closed)
- ② Non-Ex / Ex i / IS: Right side (with weather protection closed)
- ③ Non-Ex / Ex i / IS: Front view (with weather protection closed)
- ④ Optional output / Ex d / XP: Rear view (with weather protection closed)
- ⑤ Optional output / Ex d / XP: Right side (with weather protection closed)
- ⑥ Optional output / Ex d / XP: Front view (with weather protection closed)

Dimensions and weights in mm and kg

Weather protection	Version	Dimensions [mm]				Weights [kg]
		a	b	c	d	
Vertical signal converter	Non-Ex / Ex i / IS	241	118	96	77	1.3
	Optional output / Ex d / XP	241	118	166	77	1.5

Dimensions and weights in inches and lb

Weather protection	Version	Dimensions [inches]				Weights [lb]
		a	b	c	d	
Vertical signal converter	Non-Ex / Ex i / IS	9.5	4.6	3.8	3.0	2.9
	Optional output / Ex d / XP	9.5	4.6	6.5	3.0	3.3

Weather protection option (horizontal signal converters – for the compact version only)

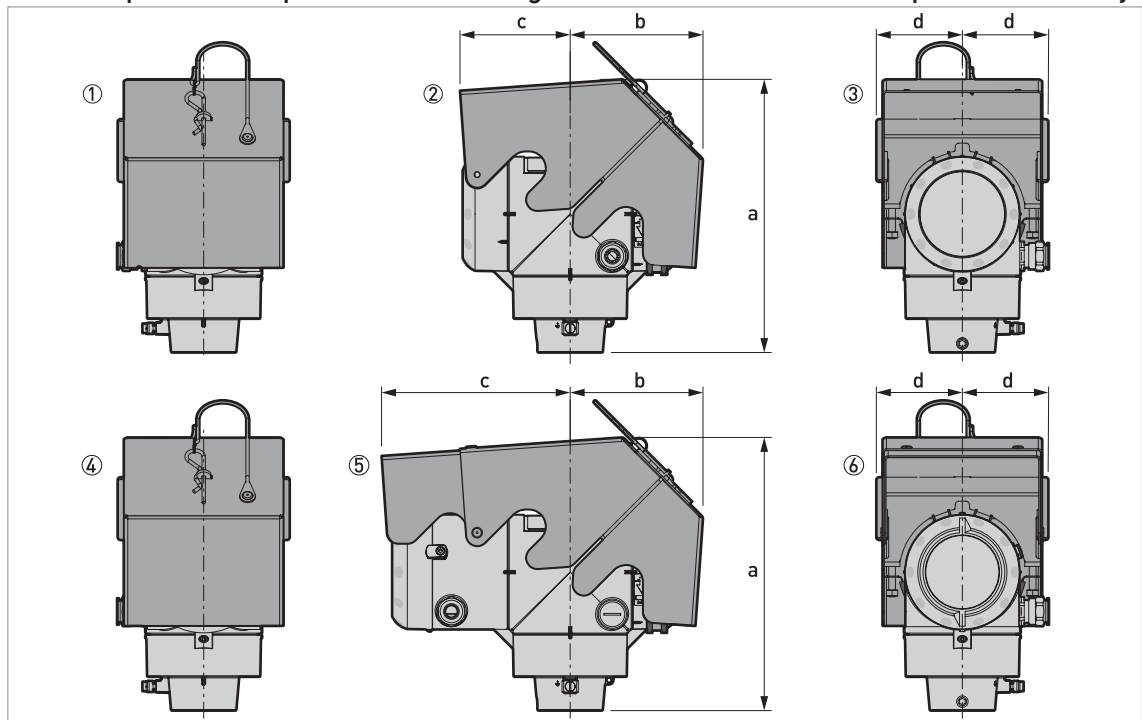

Figure 2-6: Weather protection option for horizontal signal converter versions (compact version only)

- ① Non-Ex / Ex i / IS: Front view (with weather protection closed)
- ② Non-Ex / Ex i / IS: Left side (with weather protection closed)
- ③ Non-Ex / Ex i / IS: Rear view (with weather protection closed)
- ④ Optional output / Ex d / XP: Front view (with weather protection closed)
- ⑤ Optional output / Ex d / XP: Left side (with weather protection closed)
- ⑥ Optional output / Ex d / XP: Rear view (with weather protection closed)

Dimensions and weights in mm and kg

Weather protection	Version	Dimensions [mm]				Weights [kg]
		a	b	c	d	
Horizontal signal converter	Non-Ex / Ex i / IS	243	118	96	77	1.3
	Optional output / Ex d / XP	243	118	166	77	1.5

Dimensions and weights in inches and lb

Weather protection	Version	Dimensions [inches]				Weights [lb]
		a	b	c	d	
Horizontal signal converter	Non-Ex / Ex i / IS	9.6	4.6	3.8	3.0	2.9
	Optional output / Ex d / XP	9.6	4.6	6.5	3.0	3.3

Probe options

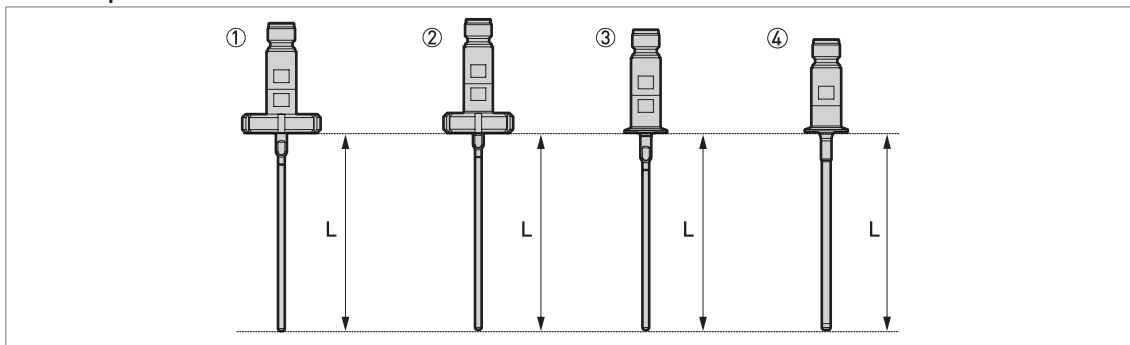

Figure 2-7: Probe options

L = probe length

- ① Polished single rod $\varnothing 8$ mm / $\varnothing 0.32$ ". SMS connection.
- ② Polished single rod $\varnothing 8$ mm / $\varnothing 0.32$ ". DIN "11851 connection.
- ③ Polished single rod $\varnothing 8$ mm / $\varnothing 0.32$ ". Tri-Clamp® connection.
- ④ Single rod $\varnothing 10$ mm / $\varnothing 0.39$ " with TFM-T62 (PTFE) coating. Tri-Clamp® connection.

Single probes: Dimensions in mm

Probes	Dimensions [mm]	
	L min.	L max.
Polished single rod $\varnothing 8$ mm	600 ①	4000
Single rod $\varnothing 10$ mm with TFM-T62 (PTFE) coating	600 ①	4000

① A shorter probe length is available on request

Single probes: Dimensions in inches

Probes	Dimensions [inches]	
	L min.	L max.
Polished single rod $\varnothing 0.32$ "	24 ①	158
Single rod $\varnothing 0.39$ " with TFM-T62 (PTFE) coating	24 ①	158

① A shorter probe length is available on request

Converter and probe electronics housing weights

Type of housing	Weights			
	Aluminium housing		Stainless steel housing	
	[kg]	[lb]	[kg]	[lb]

One output / Non-Ex / intrinsically-safe (Ex i / IS)

Compact converter	2.8	6.2	6.4	14.1
Remote converter ①	2.5	5.5	5.9	13.0
Probe electronics housing ①	1.8	4.0	3.9	8.6

Optional output / Explosion proof (Ex d / XP)

Compact converter	3.2	7.1	7.5	16.5
Remote converter ①	2.9	6.40	7.1	15.65
Probe electronics housing ①	1.8	4.0	3.9	8.6

① The remote version of the device has a "remote converter" and a "probe electronics housing". For more data, refer to "Housing dimensions" at the start of this section.

Probe weights

Probes	Process connection	Process connection weights		Probe Weights	
		[kg]	[lb]	[kg/m]	[lb/ft]
Polished single rod Ø8 mm / Ø0.32	Tri-Clamp®	1.2...1.5	2.6...3.3	0.41 ①	0.28 ①
	SMS 1145	1.2...1.5	2.6...3.3		
	DIN 11851	1.3...1.6	2.9...3.5		
Single rod Ø10 mm / Ø0.39" with TFM-T62 (PTFE) coating	Tri-Clamp®	0.6...1	1.3...2.2	0.5 ①	0.34 ①

① This value does not include the weight of the process connection

3.1 Intended use

Responsibility for the use of the measuring devices with regard to suitability, intended use and corrosion resistance of the used materials against the measured fluid lies solely with the operator.

The manufacturer is not liable for any damage resulting from improper use or use for other than the intended purpose.

This TDR level transmitter measures distance, level, interface, mass and volume of liquids, pastes and slurries.

It can be installed on tanks and reactors.

3.2 How to prepare the tank before you install the device

To avoid measuring errors and device malfunction, obey these precautions.

3.2.1 General information for nozzles

Follow these recommendations to make sure that the device measures correctly. They have an effect on the performance of the device.

Do not put the process connection near to the product inlet. If the product that enters the tank touches the probe, the device will measure incorrectly.

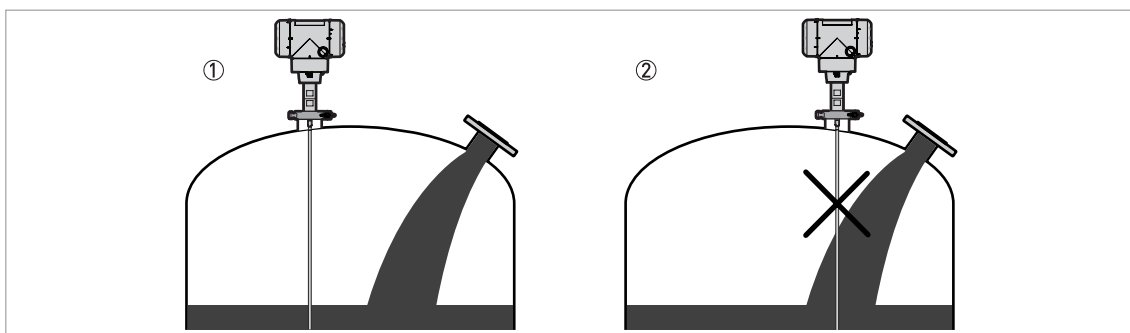

Figure 3-1: Do not put the device near to a product inlet

- ① The device is in the correct position
- ② The device is too near to the product inlet

3.3 Installation recommendations for liquids

3.3.1 General requirements

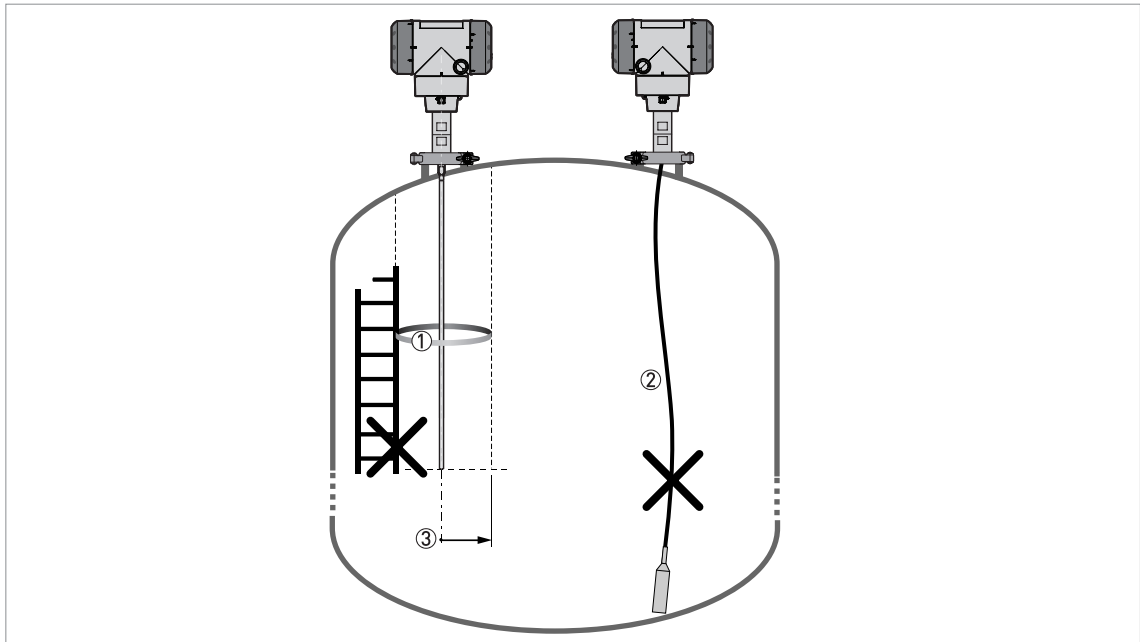

Figure 3-2: Installation recommendations for liquids

- ① The electromagnetic (EM) field generated by the device. It has a radius of R_{min} . Make sure that the EM field is clear of objects and product flow. Refer to the table that follows.
- ② Keep the probe straight.
- ③ Empty space. Refer to the table that follows.

Clearance between the probe and other objects in the tank

Probe type	Empty space (radius, R_{min}), around the probe	
	[mm]	[inches]
Single rod	300	12

4.1 Electrical installation: 2-wire, loop-powered

4.1.1 Compact version

Output 1 energizes the device and is used for HART® communication. If the device has the second current output option, use a separate power supply to energize output 2. If the device has a switch output - relay option, use a separate power supply (connect the power supply to the switch power supply terminals).

Terminals for electrical installation (one output)

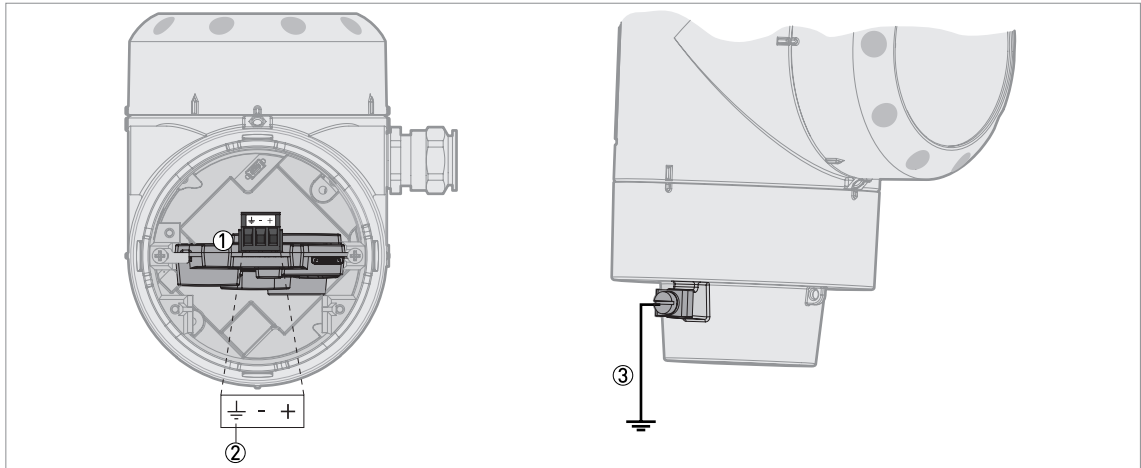

Figure 4-1: Terminals for electrical installation (one output)

- ① Current output 1
- ② Grounding terminal in the housing (if the electrical cable is shielded)
- ③ Location of the external grounding terminal (at the bottom of the converter)

Terminals for electrical installation (two current outputs)

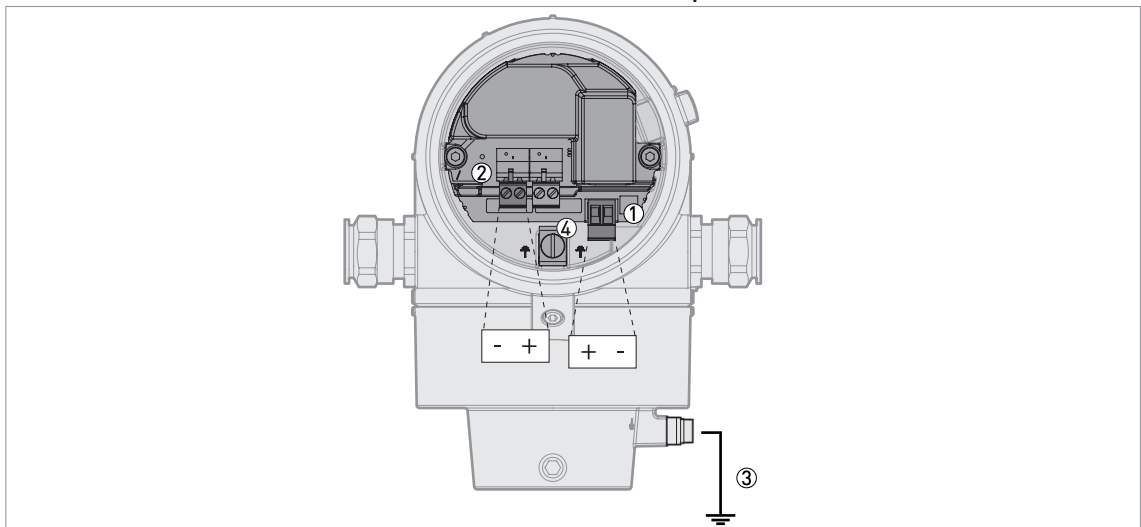

Figure 4-2: Terminals for electrical installation (two current outputs)

- ① Output 1: Terminals
- ② Output 2: Terminals
- ③ Location of the external grounding terminal (at the bottom of the converter)
- ④ Grounding terminal in the housing (if the electrical cable is shielded)

Terminals for electrical installation (one current output and one switch output - relay)

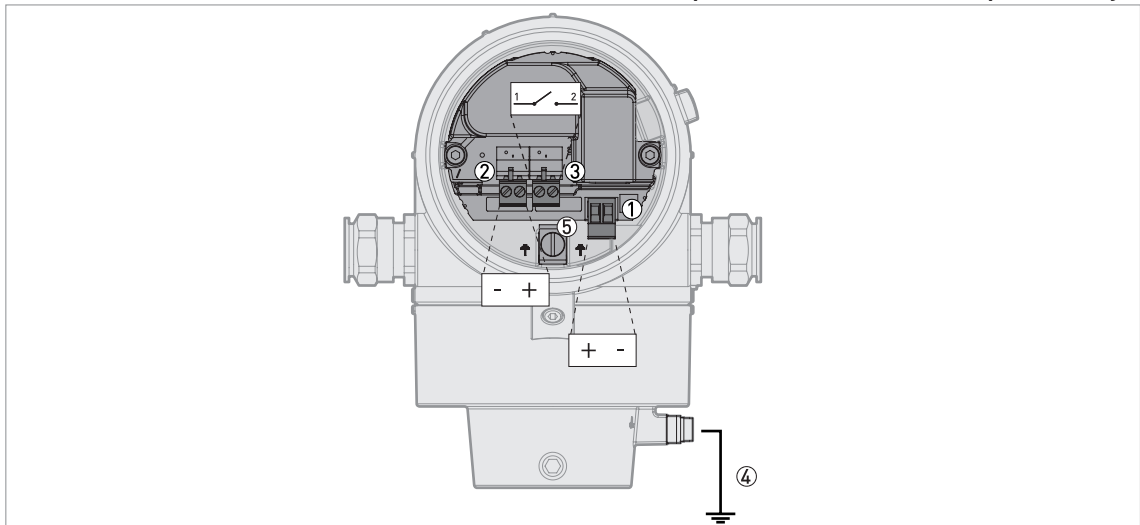

Figure 4-3: Terminals for electrical installation (one current output and one switch output - relay)

- ① Current output 1: Terminals
- ② Switch power supply: Terminals
- ③ Switch output - relay: Terminals
- ④ Location of the external grounding terminal (at the bottom of the converter)
- ⑤ Grounding terminal in the housing (if the electrical cable is shielded)

4.1.2 Remote version

Output 1 energizes the device and is used for HART® communication. If the device has the second current output option, use a separate power supply to energize output 2. If the device has a switch output - relay option, use a separate power supply (connect the power supply to the switch power supply terminals).

Terminals for electrical installation (one output)

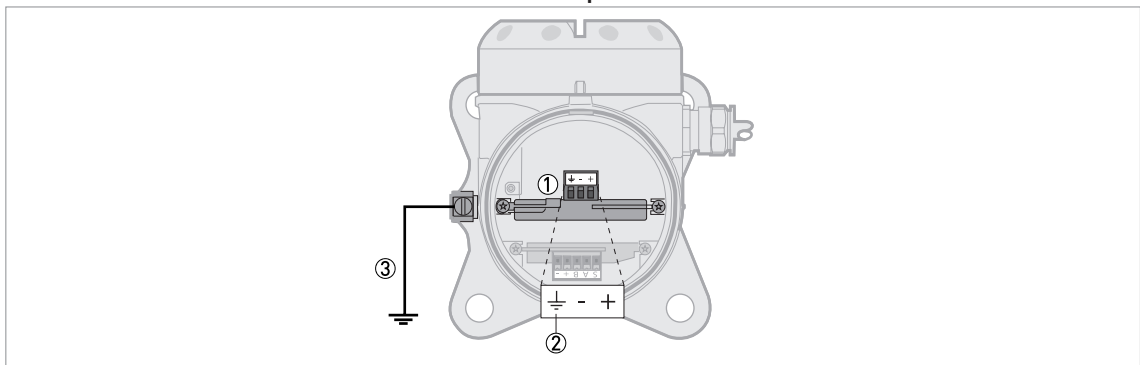

Figure 4-4: Terminals for electrical installation (one output)

- ① Current output 1: Terminals
- ② Grounding terminal in the housing (if the electrical cable is shielded)
- ③ Location of the external grounding terminal (on the wall support)

Terminals for electrical installation (two current outputs)

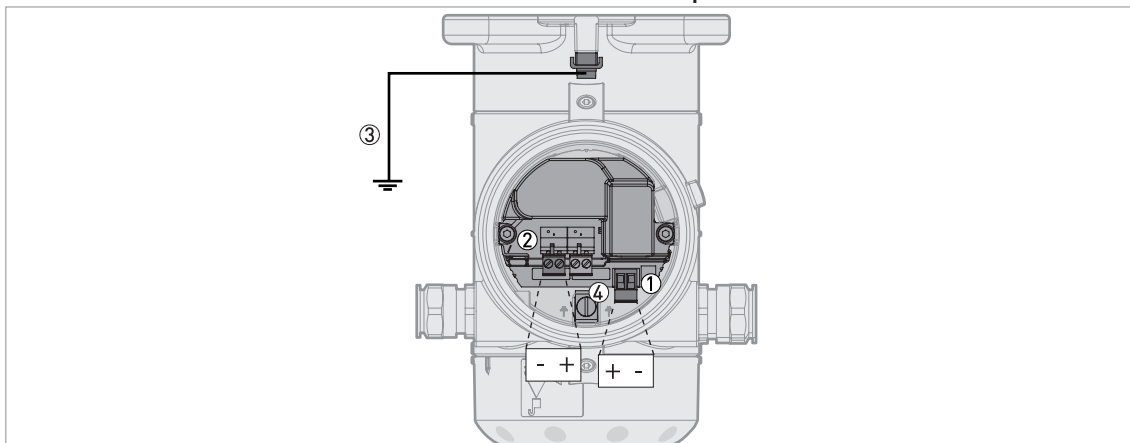

Figure 4-5: Terminals for electrical installation (two current outputs)

- ① Output 1: Terminals
- ② Output 2: Terminals
- ③ Location of the external grounding terminal (on the wall support)
- ④ Grounding terminal in the housing (if the electrical cable is shielded)

Terminals for electrical installation (one current output / one switch output - relay)

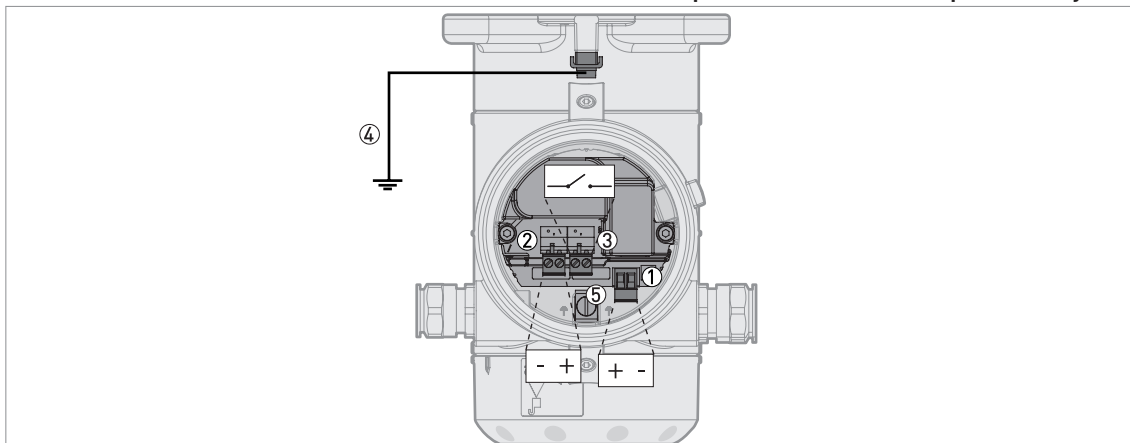

Figure 4-6: Terminals for electrical installation (one current output / one switch output - relay)

- ① Current output 1: Terminals
- ② Switch power supply: Terminals
- ③ Switch output - relay: Terminals
- ④ Location of the external grounding terminal (on the wall support)
- ⑤ Grounding terminal in the housing (if the electrical cable is shielded)

Connections between the remote converter and the probe housing (one output)

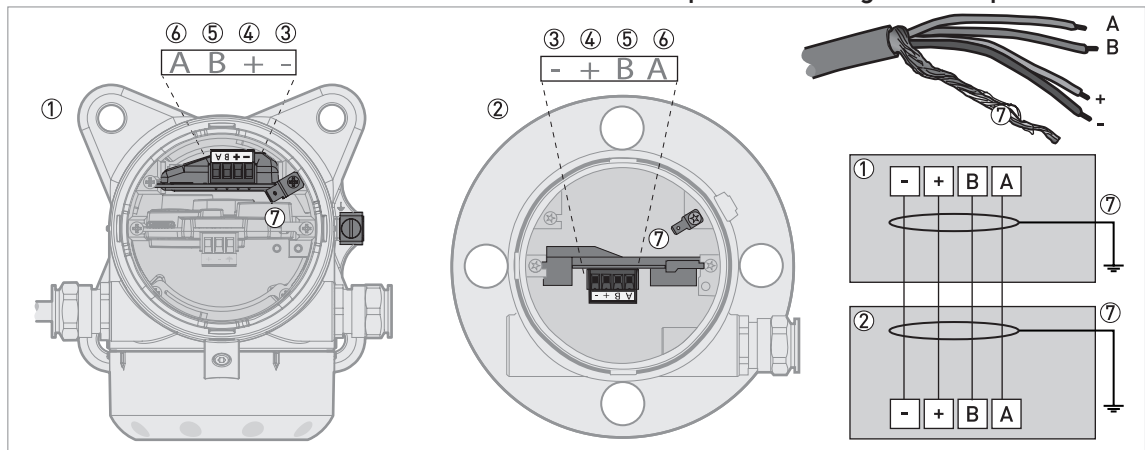

Figure 4-7: Connections between the remote converter and the probe housing (one output)

- ① Remote converter
- ② Probe housing
- ③ Power supply: voltage in -
- ④ Power supply: voltage in +
- ⑤ Signal cable B
- ⑥ Signal cable A
- ⑦ Shielding wire (attached to Faston connectors in the housings of the remote converter and the probe housing)

4.2 Non-Ex devices

Two current outputs and the switch output - relay are supplied together as a device option. Two current outputs or the switch output - relay are only available if you send an order for a device with these options.

For more data about current output functions, the switch function and related settings, refer to the "Operation" chapter in the handbook.

One current output

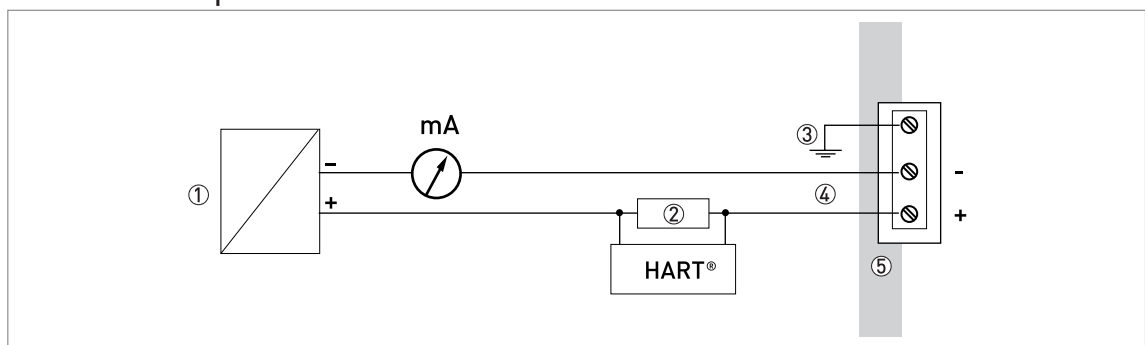

Figure 4-8: Electrical connections for non-Ex devices (one current output)

- ① Power supply
- ② Resistor for HART® communication
- ③ Optional connection to the grounding terminal
- ④ Output: 11.5...30 V DC for an output of 22 mA at the terminal
- ⑤ Device

Two current outputs

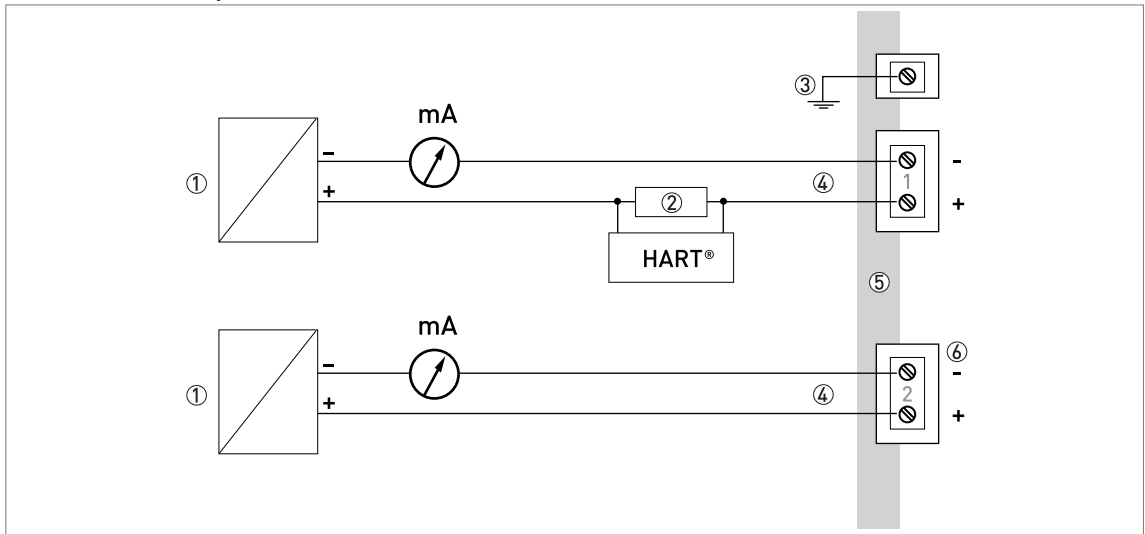

Figure 4-9: Electrical connections for non-Ex devices (two current outputs)

- ① Power supply
- ② Resistor for HART® communication
- ③ Optional connection to the grounding terminal
- ④ Output 1 and 2: 11.5...30 V DC for an output of 22 mA at the terminals
NOTE: Use a separate power supply to energize output 2
- ⑤ Device
- ⑥ Connector for the optional second output

One current output and one switch output - relay

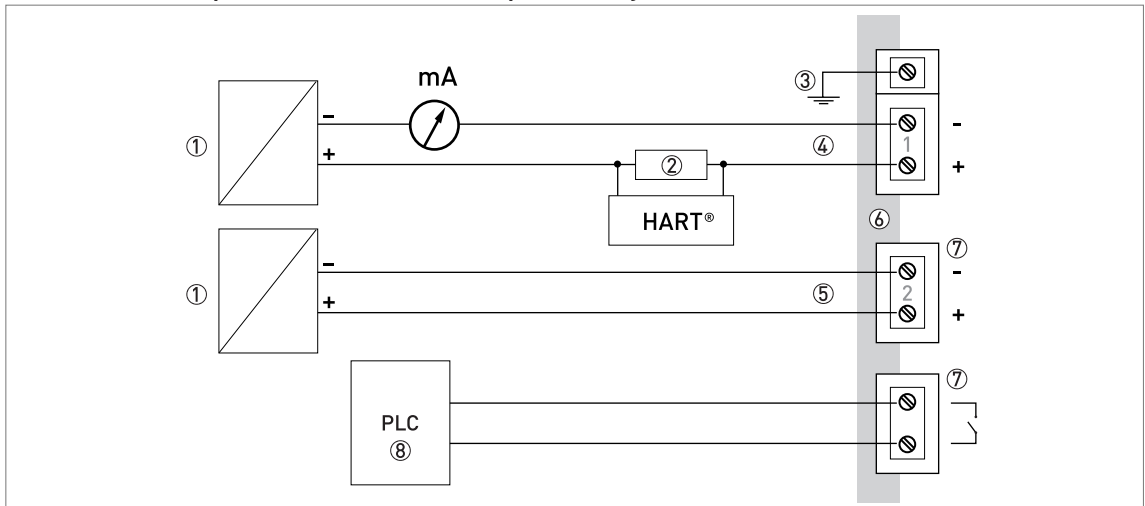

Figure 4-10: Electrical connections for non-Ex devices (one current output and one switch output - relay)

- ① Power supply
- ② Resistor for HART® communication
- ③ Optional connection to the grounding terminal
- ④ Output 1: 11.5...30 V DC for an output of 22 mA at the terminals
- ⑤ Switch power supply [2]: 11.5...34 V DC / 30 mA
NOTE: Use a separate power supply to energize the switch output - relay option
- ⑥ Device
- ⑦ Connector for the switch output - relay
- ⑧ PLC (for example)

4.3 Devices for hazardous locations

For electrical data for device operation in hazardous locations, refer to the related certificates of compliance and supplementary instructions (ATEX, IECEx etc.). This documentation can be downloaded from the website (Download Center).

4.4 Networks

4.4.1 General information

The device uses the HART® communication protocol. This protocol agrees with the HART® Communication Foundation standard. The device can be connected point-to-point. It can also have a polling address of 1 to 63 in a multi-drop network.

The device output is factory-set to communicate point-to-point. To change the communication mode from **point-to-point** to **multi-drop**, refer to "Network configuration" in the handbook.

4.4.2 Point-to-point networks

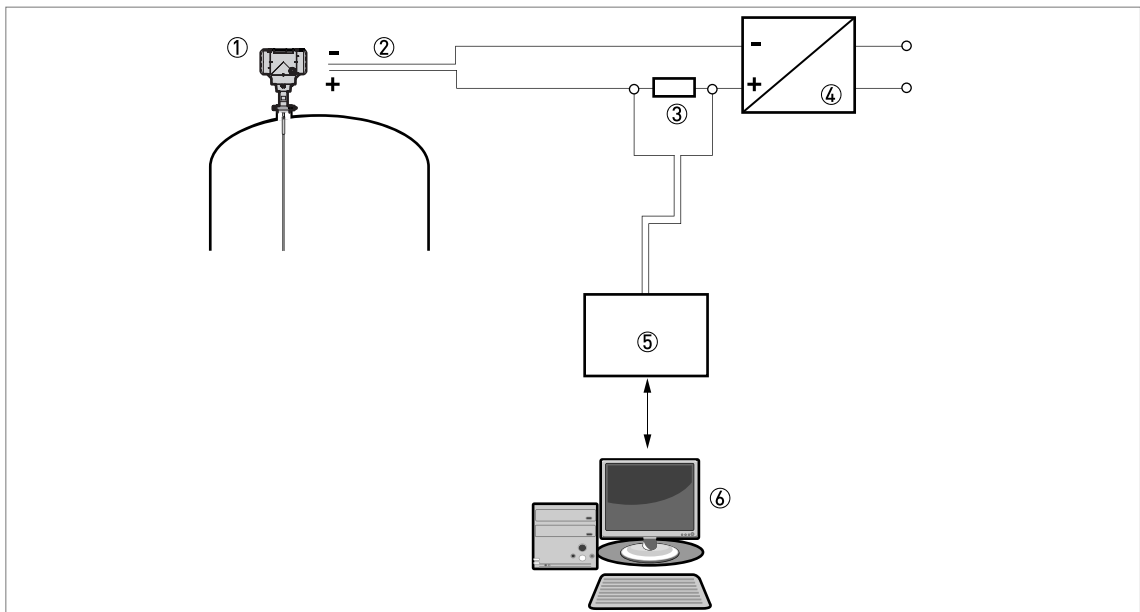

Figure 4-11: Point-to-point connection (non-Ex)

- ① Address of the device (0 for a point-to-point connection)
- ② 4...20 mA + HART®
- ③ Resistor for HART® communication
- ④ Power supply
- ⑤ HART® modem
- ⑥ HART® communication device

4.4.3 Multi-drop networks

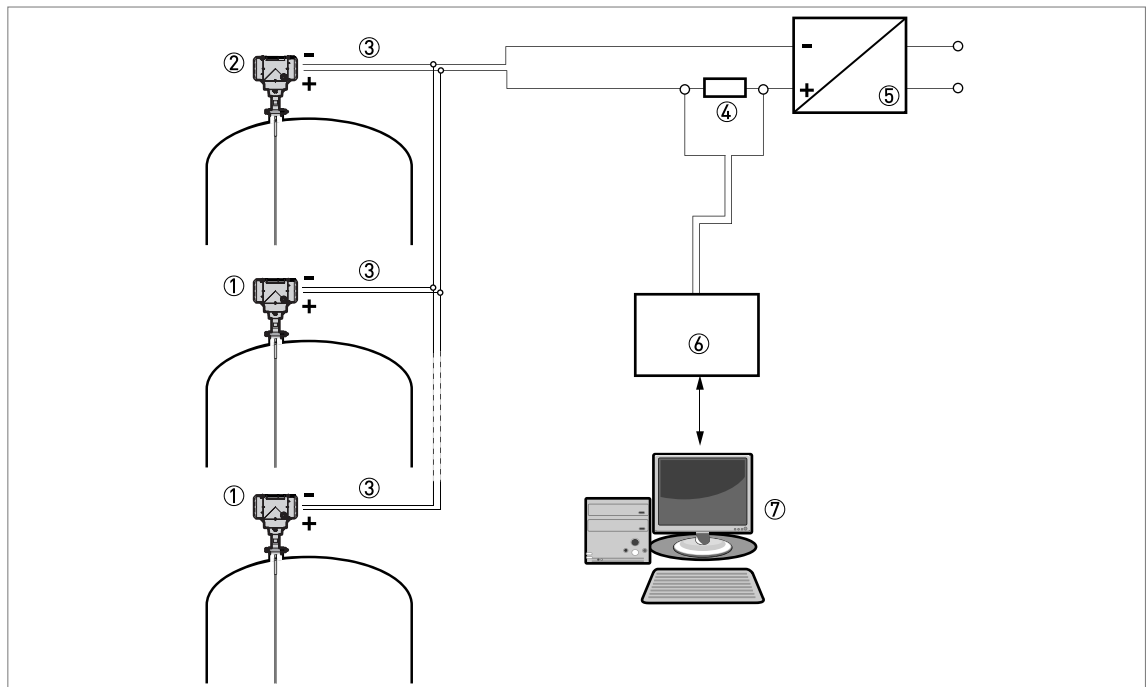

Figure 4-12: Multi-drop network (non-Ex)

- ① Address of the device (n+1 for multidrop networks)
- ② Address of the device (1 for multidrop networks)
- ③ 4 mA + HART®
- ④ Resistor for HART® communication
- ⑤ Power supply
- ⑥ HART® modem
- ⑦ HART® communication device

5.1 Order code

Make a selection from each column to get the full order code. The characters of the order code highlighted in light grey describe the standard.

VFAD	4	0	OPTIFLEX 3200 C/F Guided Radar (TDR) level transmitter for liquids with hygienic requirements up to 40 barg (580 psig) and +150°C (+302°F)
			Regional directives or approvals
		1	Europe
		2	China
		3	USA
		4	Canada
		5	Brazil
		6	Australia
		A	Russia
		B	Kazakhstan
		C	Belarus
		W	Worldwide
			Ex approval ①
		0	Without
		1	ATEX II 1/2 G Ex ia IIC T6...T3 Ga/Gb + II 1/2 D Ex ia IIIC T85°C...T150°C Da/Db
		2	ATEX II 1/2 G Ex ia/db IIC T6...T3 Ga/Gb + II 1/2 D Ex ia/tb IIIC T85°C...T150°C Da/Db
		3	ATEX II 3 G Ex ic IIC T6...T3 Gc + II 3 D Ex ic IIIC T85°C...T150°C Dc
		4	ATEX II 3 G Ex ic nA T6...T3 Gc
		5	NEPSI Ex ia IIC T3~T6 Ga/Gb + Ex iaD 20/21 T85~T150
		6	NEPSI Ex d ia IIC T3~T6 Ga/Gb + Ex iaD 20 tD A21 IP6X T85°C~T150°C
		A	cQPSus IS CL I/II/III DIV 1 GP A-G + CL I Z0 AEx ia/Ex ia IIC T6...T3 Ga + Z20 AEx ia/Ex ia IIIC T85°C...T150°C Da
		B	cQPSus XP-IS/DIP-IS CL I DIV 1 GP A-G + CL I Z1 AEx db ia/Ex db ia IIC T6...T3 Gb + Z21 AEx ia tb/Ex ia tb IIIC T85°C...T150°C Db
		C	cQPSus NI CL I/II/III DIV 2 GP ABCDFG
		K	IECEX Ex ia IIC T6...T3 Ga/Gb + Ex ia IIIC T85°C...T150°C Da/Db
		L	IECEX Ex ia/db IIC T6...T3 Ga/Gb + Ex ia/tb IIIC T85°C...T150°C Da/Db
		M	IECEX Ex ic IIC T6...T3 Gc + Ex ic IIIC T85°C...T150°C Dc
		N	IECEX Ex ic nA IIC T6...T3 Gc
		P	EAC Ex Ga/Gb Ex ia T6...T3 X + Da/Db Ex ia IIIC T85°C...T150°C X ②
		R	EAC Ex Ga/Gb Ex ia/db IIC T6...T3 X + Da/Db Ex ia/tb IIIC T85°C...T150°C X ②
VFAD	4	0	Order code (complete this code on the pages that follow)

										Display - Documentation language
										1 English ®
										2 German
										3 French
										4 Italian
										5 Spanish
										6 Portuguese
										7 Japanese
										8 Chinese (simplified)
										A Russian
										B Czech
										C Turkish
										D Polish
										Enhanced functions
										0 Without
										1 Interface capability
										Process conditions /Process seal
										0 Without
										1 -1...40 barg (-14.5...580 psig) / -40°C...+150°C (-40°F...+302°F) / PEEK seal system with FKM/FPM gasket
										2 -1...40 barg (-14.5...580 psig) / -20°C...+150°C (-4°F...+302°F) / PEEK seal system with Kalrez® 6221 gasket
										3 -1...40 barg (-14.5...580 psig) / -50°C...+150°C (-58°F...+302°F) / PEEK seal system with EPDM gasket
										4 -1...40 barg (-14.5...580 psig) / -50°C...+150°C (-58°F...+302°F) / Fully TFM-T62 PTFE-coated
										Probe / Probe end / Material
										0 Without
										1 Single rod - Ø8 mm (0.32") Ra≤0.76 µm / none / 316L - 1.4404 / 0.6...4 m (1.97...13.12 ft)
										4 Single rod - Ø10 mm (0.39") / none / fully TFM-T62 PTFE-coated / 0.6...4 m (3.28...13.12 ft)
										0 Process connection : Size / Pressure class / Sealing face
										0 0 0 Without
										Hygienic Ra≤0.76 µm (≤30 µin - AARH)
										E F S 1" Tri-Clamp® ISO 2852 DN25
										G F S 1½" Tri-Clamp® ISO 2852 DN38
										H F S 2" Tri-Clamp® ISO 2852 DN51
										E F T DN25 DIN 11851
										G F T DN40 DIN 11851
										H F T DN50 DIN 11851
										G F U DN38 SMS 1145
										H F U DN51 SMS 1145
VFAD	4	0		0					0	Order code (complete this code on the pages that follow)









KROHNE – Process instrumentation and measurement solutions

- Flow
- Level
- Temperature
- Pressure
- Process Analysis
- Services

Head Office KROHNE Messtechnik GmbH
Ludwig-Krohne-Str. 5
47058 Duisburg (Germany)
Tel.: +49 203 301 0
Fax: +49 203 301 10389
info@krohne.com

The current list of all KROHNE contacts and addresses can be found at:
www.krohne.com

