

Rosemount™ OCX8800

Oxygen and Combustibles Transmitter

- **Oxygen and combustibles measurements** in a single, easy-to-install transmitter design
- **Integral or remote-mounted** electronics options
- **Fully field-repairable**
- **NEW Software Features**
 - The first and only oxygen and combustibles analyzer to support FOUNDATION®Fieldbus
 - HART® and AMS/PlantWeb® compatible
 - Air purge cycle and improves cell calibration and effectiveness
- **NEW Hardware Features**
 - Optional factory built auto-calibration panel
 - Internal filter for use in higher than normal particulate levels¹
 - Additional in-situ filters
 - Large surface area filter for higher particulate levels
 - Stainless steel and hastelloy filters
 - Optional HART wireless communications
- **Certifications**
 - ATEX, FM, CSA Type4X/IP66, IECEx, CE, NEPSI



Optional **WirelessHART** THUM



HART standard or



¹ Application form must be completed for coal fired or other applications with high particulate levels.

Continued Improvements of the Oxygen/Combustibles Transmitter

Emerson enhances the design of the Rosemount OCX product line through continuous innovation. Due to improvements to the combustibles sensor and software to enhance the reliability of these measurements, the OCX leads the industry. The new sensor design and software upgrades make the OCX 8800 even more dependable.

The power of this rugged and reliable design coupled with the inherent advantages of FOUNDATION Fieldbus makes the OCX 8800 unmatched in overall performance. The ability to get real time diagnostic information as well as the measurement variables over the Fieldbus data highway makes the use of this analytical device even easier.

Emerson retains its position of leadership in the industry, because of the original rugged transmitter design concept of Rosemount products and additional improvements with a more stable sensor, electronics, and software package. The time-tested and world-renowned zirconium oxide sensor used in the Oxymitter In-Situ Oxygen Transmitter is still the basis for the oxygen measurement. This, coupled with the improved combustibles sensor using Rosemount's catalytic bead technology offers the ability to measure both oxygen and combustibles concentrations in flue gases with temperatures up to 2600 °F (1427 °C). Typical applications include:

- Refinery process heaters
- Power and utility boilers
- Petrochemical reactor furnaces
- Small package hot water and steam boilers
- Waste fuel boilers and incinerators

For traditional installations, two separate 4-20 mA signals are used as outputs for this transmitter. The two independent 4-20 mA signals are used for the oxygen measurement and combustibles measurement. They are fully field-scalable to each processes requirement. If the Fieldbus option is chosen, all information is transmitted via the Fieldbus H1 data highway over a single twisted pair of wires, thus reducing installation costs. The device can be configured for general purpose installations or hazardous area locations. The hazardous area ratings are CSA/FM Class 1, Zone 1 for North America and ATEX II 2 G Exd for the European community, and IECEx for all other world areas.

The OCX extends its Plantweb® connectivity by adding optional Fieldbus capability to the traditional HART based protocol. Fieldbus and HART protocols are accessible via a Model 475 Field Communicator. HART can additionally be accessed through a PC-based system using AMS software. The flexibility of Fieldbus or HART options enables Emerson's Plantweb® customers to use field-based architecture. This makes it easier for technicians to view all diagnostic and operational parameters from any location where an on-line PC is running with AMS and/or a Fieldbus capable Distributed Control System (DCS). This reduces both commissioning/start-up time as well as down-time due to troubleshooting the analyzer. The local operator interface (LOI) is a vacuum fluorescent display and is easier to see than an LCD. This makes local setup through the LOI easier and also permits visibility to diagnostics without a Model 475 Field Communicator. The OCX 8800 also has a configurable relay output for alarms.

The sensors are close-coupled to the process for minimal sample handling requirements. An eductor draws a sample past the filter in the sample block and past the sensors, then returns it to the process. The sample block filter is easily maintained and accessible right at the OCX flange. There are several new optional in-situ filters giving a broader variety of application options. The sample tube and in-situ filter has an optional blow back capability for processes with high particulate. Dilution air is added in the combustible sensor chamber to maintain a true combustibles measurement even in the absence of oxygen in the process. This feature allows measurements to be made while certain upset conditions exist such as burner fouling, process tube leaks, major variations in fuel BTU values and loss of flame.

OCX 8800

Completely Field-Repairable

The OCX 8800 is fully field-repairable. The probe’s design provides convenient access to internal probe components and electronics so technicians can service the unit in-house. The sensing cell and heater/thermocouple are fully field-replaceable. We offer sample probes in different materials and lengths up to 9 feet for flue gas temperatures up to 2600 °F (1427 °C).

The electronics can be attached to the sensor housing or separately to provide a convenient location for the electronics and operator interface for integral mounted installations. We have built the oxygen/combustibles measurement around the time-proven Oxymitter In-Situ Oxygen Transmitter oxygen cell and added a combustibles measurement with dilution air. This means the combustibles measurement is valid with or without oxygen in the flue gas stream and is extremely useful in reducing conditions. This situation is ideal for optimization of your fuel/air ratio or indication of your combustion process from a safety standpoint.



OCX 8800 Housing and Electronics Stack Interface

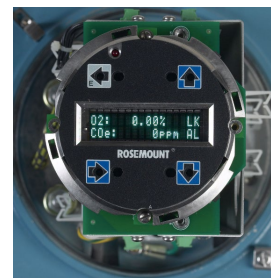

Electronics Housing Local Operator Interface, with thru-glass infrared push buttons

OCX 8800 Oxygen/combustibles transmitter features and benefits

Features	Benefits
HART and FOUNDATION Fieldbus communications	All information from analyzer is updated constantly and provided to the operator or technician. Low cost to maintain
Rapid, accurate, and reliable measurement of excess oxygen and combustibles	Provides inputs for significant fuel savings which normally pay for the analyzer in less than one year
Integrated sensors and electronics simplifies installation (optional)	Eliminates cost of mounting separate electronics as well as cabling and conduit between sensors and electronics
Temperature-controlled combustible sensor	Minimize drift and better sensitivity
Field-replaceable sensors, temperature elements and heaters	Ease-of-maintenance
Suitable for process temperatures up to 2600 °F (1427 °C)	Suitable for use in most combustion applications
Probe material of construction 316 LSS, Inconel 600, and ceramic	High resistance to corrosion and high temperatures
Optional in-situ filter for high particulate installation	Improved sample handling—block temperature control
New robust combustibles sensor	Longer life and higher resistance to sulfur
Automatic line voltage selections	Automatically selects from 90 to 240 Vac and 50/60 Hz. without configuration or set-up

Specifications¹

OCX 8800 Oxygen/comb transmitter

Net O₂ range

0-1% to 0-40%

Fully field-selectable via HART or LOI

Combustibles

0-1000 ppm to 0-5%

Fully field-selectable via HART or LOI

Accuracy

Oxygen

± .75% of reading or .05% O₂, whichever is greater

Combustibles

± 1% F.S. when calibrated at 0-5000 ppm range

System Response to Test Gas

O₂

10 sec T90

Combustibles

25 sec T90

Temperature limits

Process

32° to 2600°F (0° to 1427°C)

Sensors Housing

-40° to 212°F (-40° to 100°C)

Electronics Housing

-40° to 149°F (-40° to 65°C)

Maximum Process Pressure

8" water column

Probe lengths, Nominal and Approximate Shipping Weights

18 in (457 mm) package: 54 pounds (24.5 kg)

3 foot (0.91 m) package: 55 pounds (24.5 kg)

6 foot (1.83 m) package: 57 pounds (26 kg)

9 foot (2.74 m) package: 59 pounds (26.8 kg)

Not approved for applications where there is particulate in the combustion flue gases.

Mounting and Mounting Position

Sensor

Flange

Electronics

Wall/Pipe

¹ All static performance characteristics are with operating variables constant. Specifications subject to change without notice.

Materials

Probes

316L stainless steel - 1000°F (538°C)

Inconel 600 - 1832°F (1000°C)

Ceramic - 2600°F (1427°C)



Enclosures

Low-copper aluminum

Calibration

Semi-automatic or automatic

Calibration Gas mixtures recommended

0.4% O₂, balance N₂

8% O₂, balance N₂

1000 ppm CO, balance air

Calibration Gas Flow

7 scfh (0.5 l/m)

Reference Air

2 scfh (1 l/m), clean, dry, instrument-quality air (20.95% O₂), regulated to 35 psi (238 kPa)

Eductor Air

5 scfh (2.5 l/m), clean, dry, instrument-quality air (20.95% O₂), regulated to 35 psi (238 kPa)

Dilution Air

.1 scfh (2.8 l/hr.), clean, dry, instrument-quality air (20.95% O₂), regulated to 35 psi (238 kPa)

Blowback Air (Optional)

Clean, dry, instrument quality air (20.95% O₂) regulated to ≥ 60 psi (413 kPa) or greater and ambient temperature of ≥ 0 °F (-18 °C)

Sensors Housing

NEMA 4, IP66, Two 3/4" - 14 NPT conduit ports

Electronics Housing

NEMA 4, IP66, Two 3/4" - 14 NPT conduit ports

Electrical Noise

EN 61326-1, Class A

Optional Hazardous Area Certifications

CSA/FM Class 1, Zone 1

Ex D IIB + H₂ T3/T6

AEx D IIB + H₂ T3/T6

ATEX II 2 G Ex D IIB + H₂ T3/T6

The OCX 8800 complies with the European Union PED 97/23/EC Directive by virtue of SEP.

Specifications¹ (continued)

Line Voltage

100-240 VAC ± 10% 48-62 Hz
 No switches or jumpers required
 3/4" - 14 NPT conduit port

Isolated Output

O₂, 4-20mA_{dc}, 950 ohm maximum with HART capability COMB,
 4-20mA_{dc}, 950 ohm maximum

Alarm output relay

dry contact, 30mA and 30 VDC capacity **Logic Signals**

SPA HART ALARM module (**optional**)

Low O₂ alarm

High Comb alarm

Calibration status

Unit failure

Power Consumption limits

Power Consumption of Heaters

750 W nominal maximum

Power Consumption of Electronics

50 W nominal maximum

CE Emerson has satisfied all obligations coming from the European legislation to harmonize the product requirements in Europe.

Communicate with the OCX 8800 almost anywhere via the HART protocol

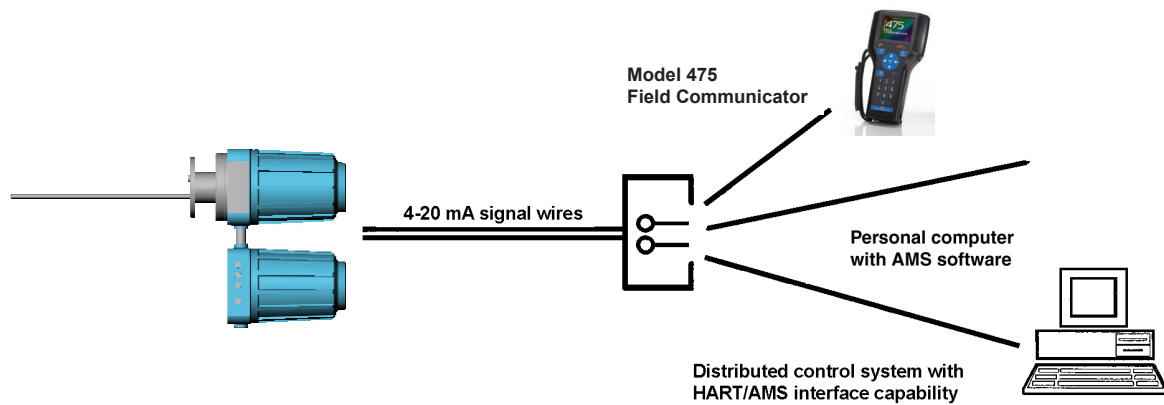

Dimensional drawings

Outline dimensions for OCX 8800 Oxygen/Combustible transmitter with integral electronics

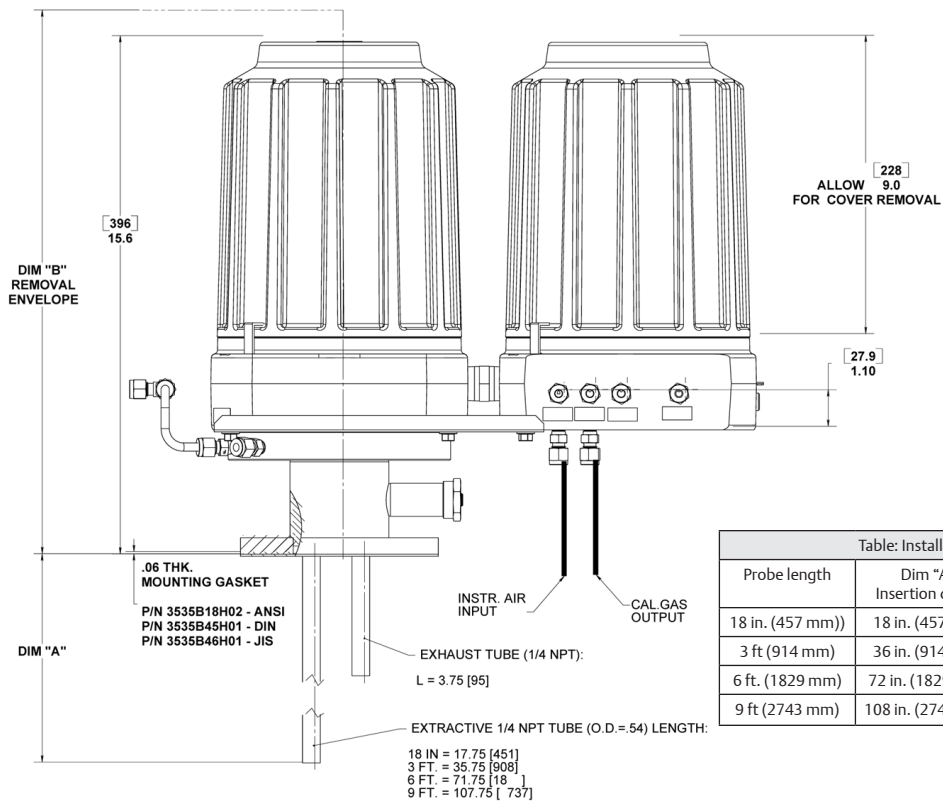
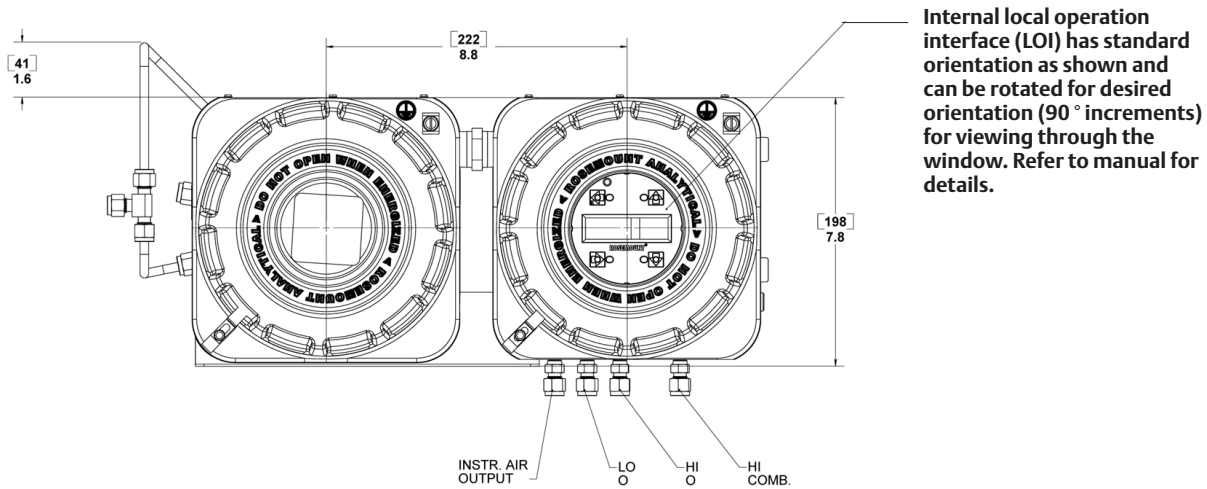

Outline dimensions for OCX 8800 Oxygen/Combustible transmitter with integral electronics

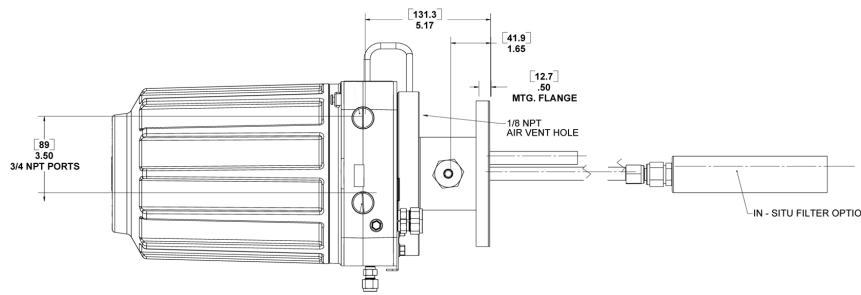
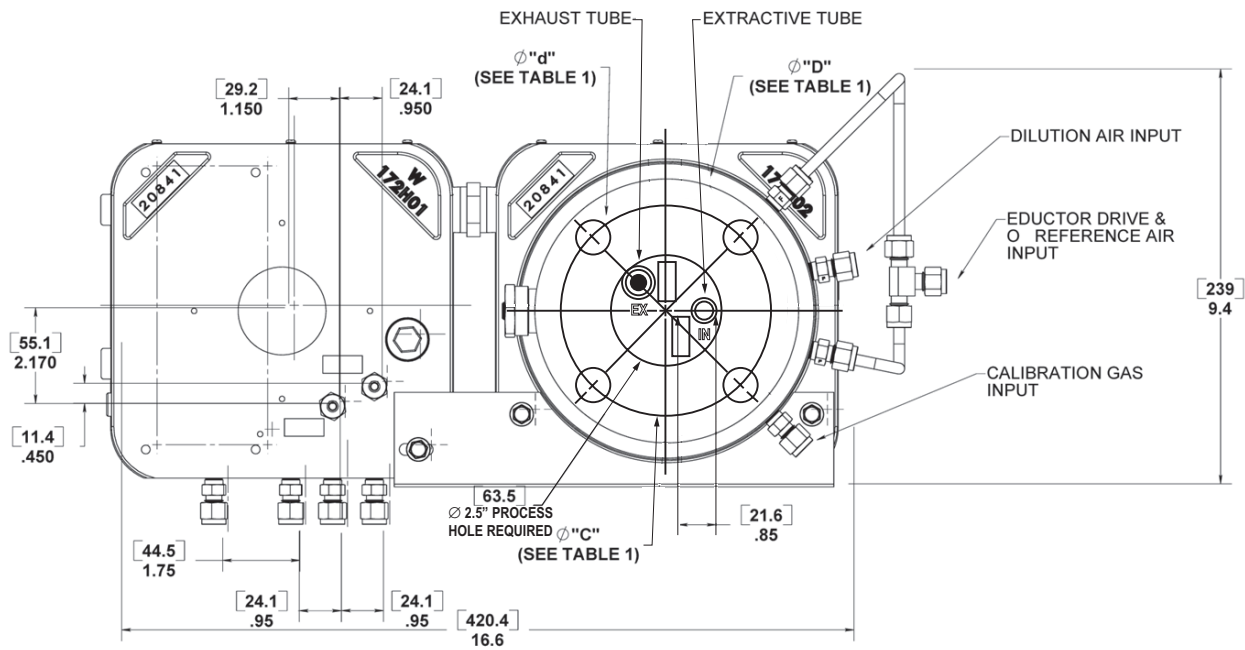

Table 1. Mounting flange dimensions: in. (mm)

Mt. flange P/N	Flange type	Flange diameter "D"	Mtg hole diam "d"	Bolt circle diam. "C"
5R10 44H01	ANSI	6.00 (150)	.75 (19)	4.75 (120)
5R10 44H0	DIN	7.80 (185)	.71 (18)	5.71 (145)
5R10 44H03	JIS	6.10 (155)	.59 (15)	5.10 (130)



Outline dimensions for OCX 8800 Oxygen/Combustible transmitter with split electronics

Electronics Housing

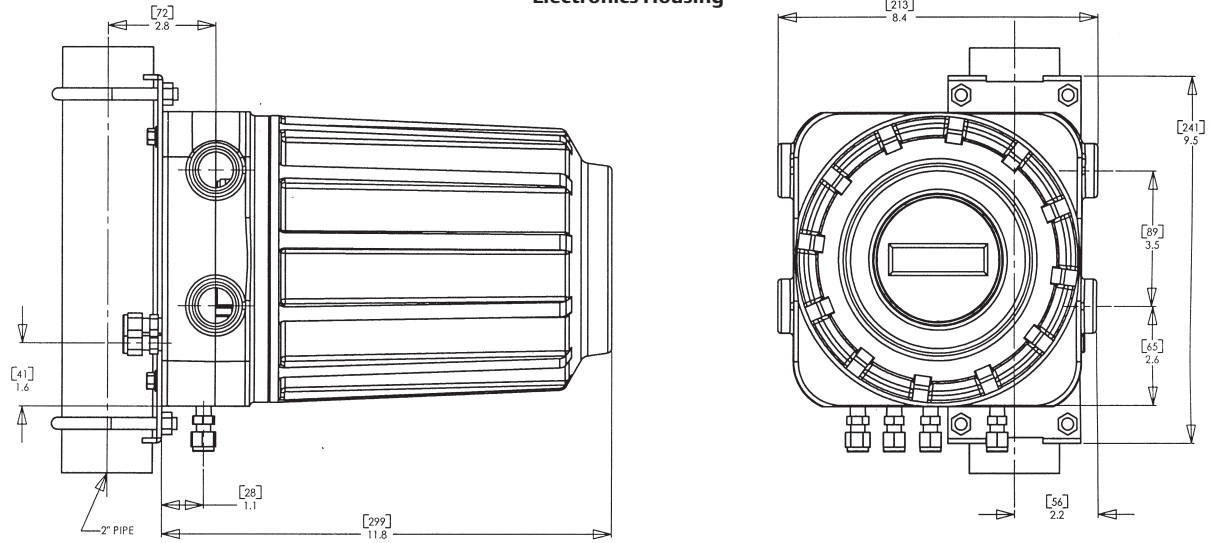

Sensor Housing

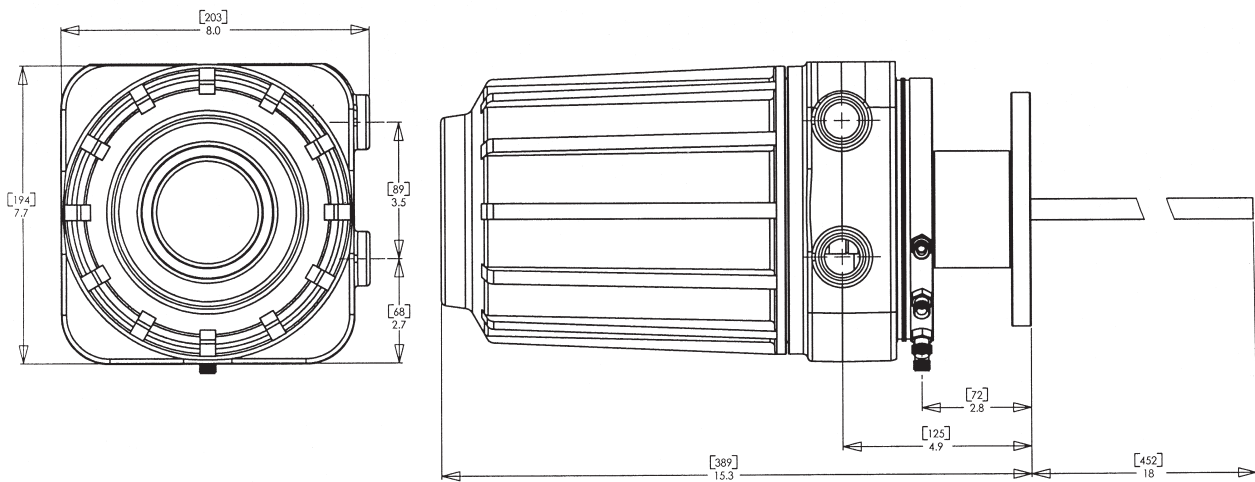

Outline dimensions for OCX 8800 Oxygen/Combustible transmitter with split electronics

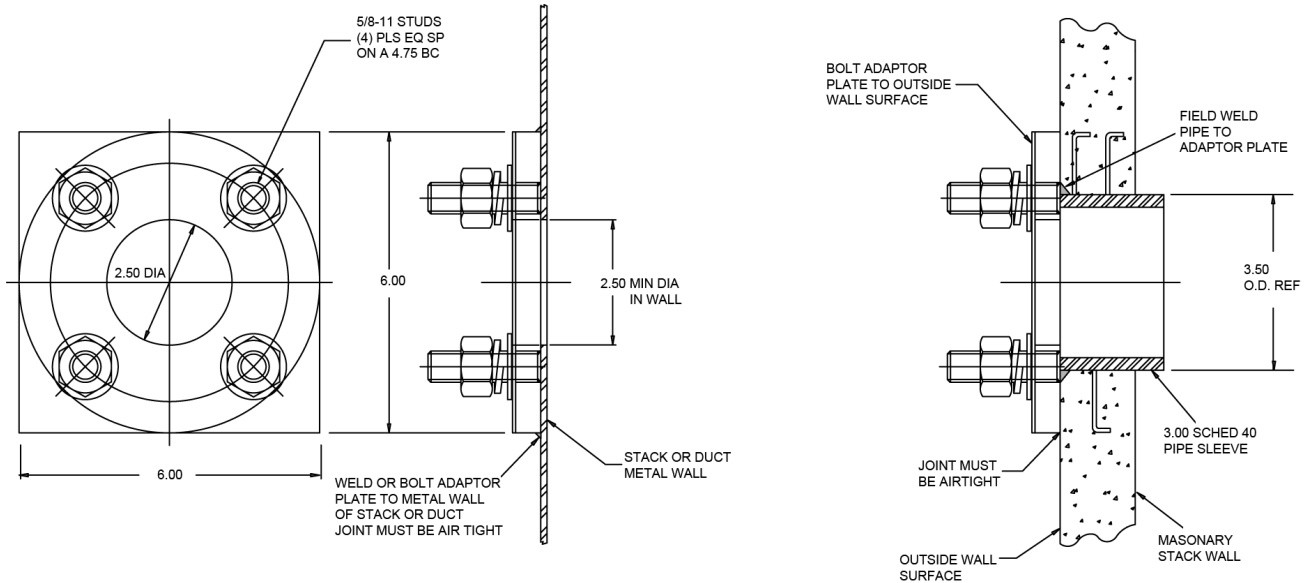

Mounting Options

	Dimensions Dia. in. (mm)	
	ANSI	DIN
Flange (x)	6.00 (153)	7.5 (190)
Stud size	5/8 in. - 11	M12 X 1.75
4 Studs Eq. Sp. on B.C.	4.75 BC	5.12 BC

Table II. Removal/Installation		
Probe Length	Dim "A" Insertion Depth	DIM "B" Removal Envelope
18 in. (457mm)	18.00 in. (457 mm)	34.00 in. (864 mm)
3 ft. (0.91m)	36.00 in. (914 mm)	52.00 in. (1321 mm)
6 ft. (1.83 m) Probes	72.00 in. (1829 mm)	88.00 in. (2235 mm)
9 ft. (2.74 m) Probes	108.00 in. (2743 mm)	124.00 in. (3150 mm)

Outline dimensions for OCX 8800 Oxygen/Combustible transmitter in-situ filters

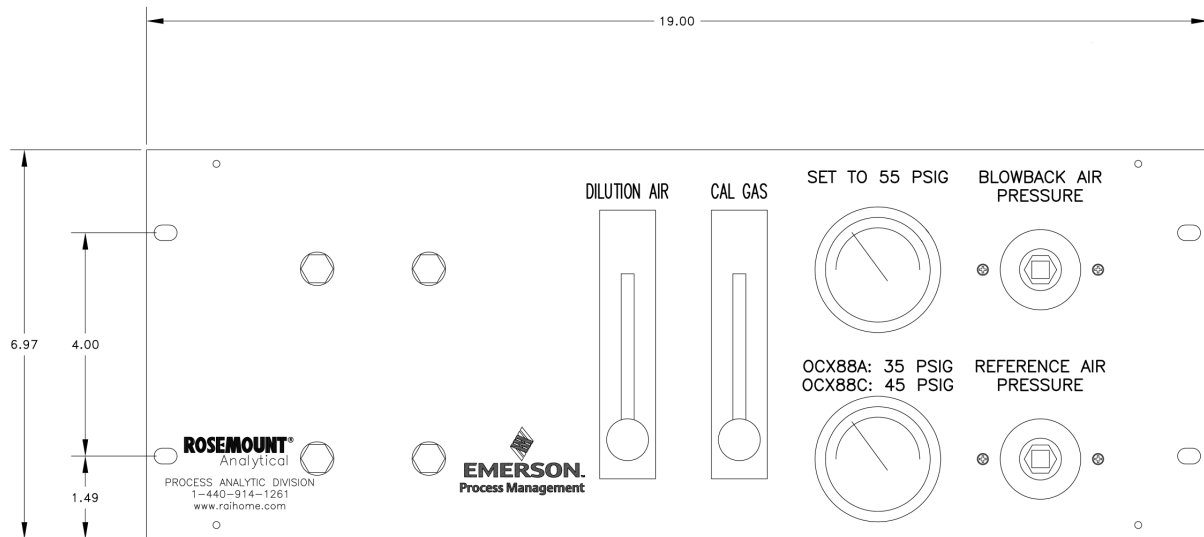

Auto-calibration panel

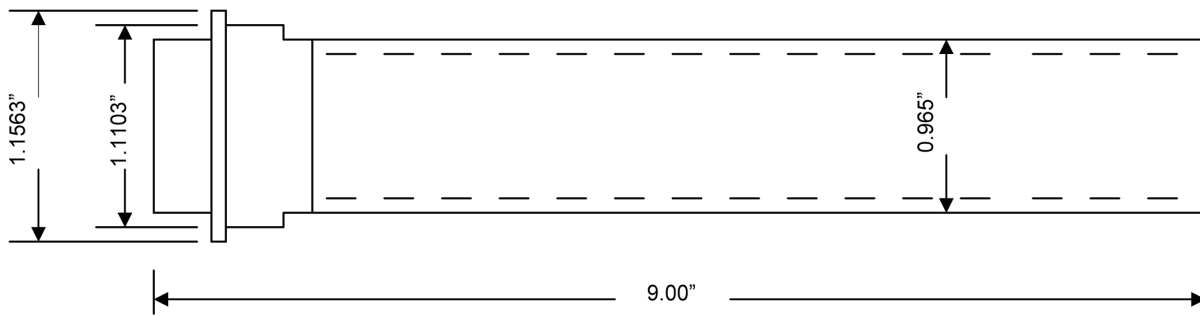

Standard stainless steel and hastelloy filters

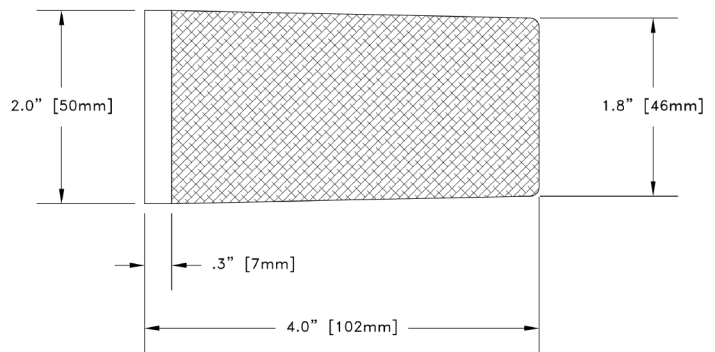
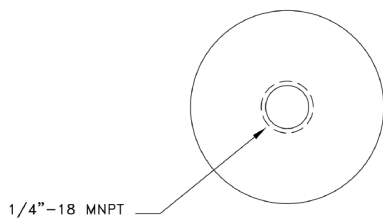

Stainless steel high surface area filter

Ordering information

OCX88A Oxygen /Combustibles Transmitter - General Purpose

Model	Product Description
OCX88A	Oxygen /Combustibles Transmitter (OCX 88A)
Probe Length and Material	
00	No probe or exhaust tube
11	18 in. (457 mm) 316 stainless steel, up to 1000 °F (538 °C)
12	3 ft (0.91m) 316 stainless steel, up to 1000 °F (538 °C)
13	6 ft (1.83 m) 316 stainless steel, up to 1000 °F (538 °C)
14	9 ft (2.74 m) 316 stainless steel, up to 1000 °F (538 °C)
21	18 in. (457 mm) Inconel 600, up to 1832 °F (1000 °C)
22	3 ft (0.91 m) Inconel 600, up to 1832 °F (1000 °C)
23	6 ft (1.83 m) Inconel 600, up to 1832 °F (1000 °C)
24	9 ft (2.74 m) Inconel 600, up to 1832 °F (1000 °C)
31	18 in. (457 mm) ceramic, up to 2600 °F (1426 °C)
32	3 ft (0.91 m) ceramic, up to 2600 °F (1426 °C)
Probe Mounting Assembly	
10	2 in. 150# ANSI flange-requires a 2.5 in. (63.5 mm) process hole, see drawing Standard O ₂ cell
11	2 in. 150# ANSI flange-requires a 2.5 in. (63.5mm) process hole, see drawing Acid-resistant O ₂ cell
20	(DIN) 185 mm diameter flange, 145 mm BC with 4 x 18 mm dia. holes (European Std) -Standard O ₂ cell
21	(DIN) 185 mm diameter flange, 145 mm BC with 4 x 18 mm dia. holes (European Std) -High sulfur O ₂ cell
Mounting Hardware - Stack Side	
0	No adapter plate (0 must also be chosen under Mounting Adapter - Probe Side below)
1	New installation - square weld plate with studs
2	Mounting to Model 218/240 mounting plate (with Model 218/240 shield removed)
3	Mounting to existing Model 218/240 support shield
4	Mounting to other mounting
5	Mounting to Model 132 adapter plate
Mounting Hardware - Probe Side	
0	No adapter plate probe side
1	Probe only (ANSI) probe side
4	Probe only (DIN) probe side
Electronic Housing - NEMA 4X, IP66 HART Communications - Std.	
F1	Fieldbus communication, basic unit
F2	Fieldbus communication, local operator interface
F3	Fieldbus communication, calibration solenoids
F4	Fieldbus communication, local operator interface and calibration solenoids
H1	HART communications, basic unit
H2	HART communications, local operator interface
H3	HART communications, calibration solenoids
H4	HART communications, local operator interface and calibration solenoids

Ordering information (continued)

OCX88A Oxygen /Combustibles Transmitter - General Purpose

Electronic Mounting ¹	
01	Integral to sensor housing electronics
02	Split electronics with no cable
03	Split electronics with 20 ft (6 m) cable
04	Split electronics with 40 ft (12 m) cable
05	Split electronics with 60 ft (18 m) cable
06	Split electronics with 80 ft (24 m) cable
07	Split electronics with 100 ft (30 m) cable
08	Split electronics with 150 ft (45 m) cable
In-Situ Filter	
0	None
1	Stainless steel
2	High surface area stainless steel
3	Hasteloy
Accessories	
0	None
1	Blowback only
2	Cal gas flow rotometers & ref. gas set
3	Cal gas flow rotometers & ref. gas set w/blowback
4	Cal gas flow rotometers & ref. gas set w/blowback, panel mounted

- Notes: (1) Cable lengths to 300 ft are possible when purchased in bulk lengths:
 6P00156H01 - Signal cable
 6P00157H01 - Power cable
- (2) For cold weather operation, preheat the instrument air by wrapping the stainless steel supply tubing around the heater neck several times and insulate with the insulating scarf, PN - 6P00162H01. The entire sensor and electronics domes may also need to be separately insulated, depending on the temperatures and wind conditions. The dome insulation may be removed during the summer months.



Ordering information

OCX88C Oxygen /Combustibles Transmitter - Explosion-Proof for hazardous area

Model	Product Description
OCX88C	Oxygen /Combustibles Transmitter - Explosion-Proof (OCX 88C)
Probe Length and Material	
00	No probe or exhaust tube
11	18 in. (457 mm) 316 stainless steel, up to 1000 °F (538 °C)
12	3 ft (0.91 m) 316 stainless steel, up to 1000 °F (538 °C)
13	6 ft (1.83 m) 316 stainless steel, up to 1000 °F (538 °C)
14	9 ft (2.74 m) 316 stainless steel, up to 1000 °F (538 °C)
21	18 in. (457 m) Inconel 600, up to 1832 °F (1000 °C)
22	3 ft (0.91 m) Inconel 600, up to 1832 °F (1000 °C)
23	6 ft (1.83 m) Inconel 600, up to 1832 °F (1000 °C)
24	9 ft (2.74 m) Inconel 600, up to 1832 °F (1000 °C)
31	18 in. (457 mm) ceramic, up to 2600 °F (1426 °C)
32	3 ft (0.91 m) ceramic, up to 2600 °F (1426 °C)
Probe Mounting Assembly	
10	2 in. 150# ANSI flange-requires a 2.5 in. (63.5 mm) process hole, see drawing Standard O ₂ cell
11	2 in. 150# ANSI flange-requires a 2.5 in. (63.5 mm) process hole, see drawing Acid-resistant O ₂ cell
20	(DIN) 185 mm diameter flange, 145 mm BC with 4 x 18 mm dia. holes (European Std) - Standard O ₂ cell
21	(DIN) 185 mm diameter flange, 145 mm BC with 4 x 18 mm dia. holes (European Std) - High sulfur O ₂ cell
Mounting Hardware - Stack Side	
0	No adapter plate (0 must also be chosen under Mounting Adapter - Probe Side below)
1	New installation - square weld plate with studs
2	Mounting to Model 218/240 mounting plate (with Model 218/240 shield removed)
3	Mounting to existing Model 218/240 support shield
4	Mounting to other mounting
5	Mounting to Model 132 adapter plate
Mounting Hardware (probe side)	
0	No adapter plate probe side
1	Probe only (ANSI) probe side
4	Probe only (DIN) probe side
Electronic Housing - NEMA 4X, IP66 HART Communications - Std.	
F1	Fieldbus communication, basic unit
F2	Fieldbus communication, local operator interface
F3	Fieldbus communication, calibration solenoids
F4	Fieldbus communication, local operator interface and calibration solenoids
H1	HART communications, basic unit
H2	HART communications, local operator interface
H3	HART communications, calibration solenoids
H4	HART communications, local operator interface and calibration solenoids

Ordering information (continued)

OCX88C Oxygen /Combustibles Transmitter - Explosion-Proof

Electronic Mounting	
01	Electronics integral to sensor housing
02	Split electronics and no cable ¹
In-Situ Filter	
0	None
1	Stainless steel
2	High surface area stainless steel
3	Hasteloy
Accessories	
0	None
1	Blowback only
2	Cal gas flow rotometers & ref. gas set
3	Cal gas flow rotometers & ref. gas set w/blowback
4	Cal gas flow rotometers & ref. gas set w/blowback, panel mounted

- Notes: (1) Cable lengths to 300 ft are possible when purchased in bulk lengths:
 6P00156H01 - Signal cable
 6P00157H01 - Power cable
- (2) For cold weather operation, preheat the instrument air by wrapping the stainless steel supply tubing around the heater neck several times and insulate with the insulating scarf, PN - 6P00162H01. The entire sensor and electronics domes may also need to be separately insulated, depending on the temperatures and wind conditions. The dome insulation may be removed during the summer months.



www.Emerson.com/RosemountGasAnalysis



[YouTube.com/user/RosemountMeasurement](https://www.youtube.com/user/RosemountMeasurement)



Analyticexpert.com



[Twitter.com/Rosemount_News](https://twitter.com/Rosemount_News)



[Facebook.com/Rosemount](https://www.facebook.com/Rosemount)

Americas

**Emerson Automation Solutions
Rosemount**

8200 Market Blvd
Chanhassen, MN 55317
USA
T + 1 855 724 2638
F + 1 949 863 9159
gas.csc@emerson.com

Europe

Emerson Automation Solutions AG

Neuhofstrasse 19a P.O. Box 1046
CH-6340 Baar
Switzerland
T + 41 (0) 41 768 6111
F + 41 (0) 41 768 6300
gas.csc@emerson.com

Middle East & Asia

Emerson Automation Solutions

Emerson FZE
Jebel Ali Free Zone
Dubai, UAE
P.O. Box 17033
T + 971 4 811 8100
F + 971 4 886 5465
gas.csc@emerson.com

Asia Pacific

Emerson Automation Solutions

1 Pandan Crescent
Singapore 128461
Singapore
T + 65 777 8211
F + 65 777 0947
gas.csc@emerson.com

©2018 Emerson Automation Solutions. All rights reserved.

The Emerson logo is a trademark and service mark of Emerson Electric Co. Rosemount and the Rosemount logotype are registered trademarks of Rosemount Inc. All other marks are the property of their respective owners.

The contents of this publication are presented for information purposes only, and while effort has been made to ensure their accuracy, they are not to be construed as warranties or guarantees, express or implied, regarding the products or services described herein or their use or applicability. All sales are governed by our terms and conditions, which are available on request. We reserve the right to modify or improve the designs or specifications of our products at any time without notice.