

The

GASENZ

**Ambient Oxygen
Monitor**

With Zirconia Sensor

User Instruction Manual

Part Number: 05-679

F/W Issue Number: V233P

Issue Date: 01/10/2018





1	Introduction	1
1.1	Gasenz	1
1.2	Operation.....	2
1.3	%Vol Sensor	3
1.4	Specification.....	4
1.5	Status Indicator.....	5
2	Physical data	6
2.1	Mounting and Dimensions	6
2.1.1	Field Connections	7
2.1.2	Field Connections –DC Supply-Option. Fig.3	8
2.1.3	Field Connections –AC Supply-Option. Fig.4.....	9
2.1.4	Mounting Locations.....	10
2.1.5	Location conditions.....	11
2.1.6	Analogue Output	12
3	Software Features	13
3.1.1	Password	13
	Menu Structure	15
3.1.2	Menu 1 – Calibrate sensor.....	16
3.1.3	Menu 2 – Analogue output FSD.....	17
3.1.4	Menu 3 – Set 4 mA output.....	17
3.1.5	Menu 4 – Set 20 mA output.....	18
3.1.6	Menu 5 – Analogue Output Simulation	18
3.1.7	Menu 6 – Factory Restore	19
3.1.8	Menu 8 - Diagnostics.....	20
	3.1.9 Menu 17 – Relay	21
3.1.10	Menu 18 – Alarm levels.....	22
3.1.11	Menu 19 – Alarm hysteresis	23
3.1.12	Menu 20	23
4	Routine Maintenance & Servicing	25
	Routine Inspection and Maintenance.....	25



Revision history:

First Issue: Rev. 1.0 11/01/2018

Menu 14 note removed: Rev.1.1 30/03/2018

New product labelling: Rev.1.2 10/05/2018`

Menu access text correction Rev.1.3 01/10/2018

1 INTRODUCTION

1.1 Gasenz

The Gasenz is a wall or surface mounting device has for the monitoring of % Oxygen volume levels in an Ambient environment.

Key design features are:

- Sturdy compact enclosure
- Status indication by means of a two-lamp beacon and sounder unit.
- Simple keypad calibration facility (utilising onboard LCD display).
- 4-20mA current source output for gas level indication (10-bit resolution).
- Input voltage range, 85-264VAC. PCB mounted screw terminals for all connections. Option of 24VDC only.





1.2 Operation

When power is first applied to the Gasenz an initialisation procedure is performed as follows:

- All the display segments are displayed
- The software version number is displayed
- The company name is displayed
- The sensor type is displayed
- The display then shows the gas level.

The Gasenz is now operational

Note: The Gasenz Oxygen Monitor is based around the Microx series of Oxygen Analyser controllers and contains some Menu programming options which are not relevant to the Gasenz product and its mode of operation.

Such menu's and information are highlighted in this user manual as 'Customer Access Not Permitted' and other various warnings against adjustment of such menu options. Please observe these prohibitions to ensure correct operation of the Gasenz Oxygen Monitor.

The Gasenz Oxygen Monitor is supplied factory configured and calibrated for correct operation, and apart from sensor replacement and periodic calibration, should require no further user intervention.



1.3 %Vol Sensor

A % Volume sensor is an integral part of the Gasenz Monitor.
The % Volume measurement range of the Gasenz Monitor/sensor combination is factory set at 0 to 25%, with calibration at 20.9% O₂ (Ambient).

The sensor utilises Zirconia technology which gives a long operational life, typically 3 to 5 years depending on application.



Note that the sensor comprises a heating element. Close contact such as grasping the body of the sensor must be avoided. Exposure to the element is only possible if the sensor is removed. Do not disassemble the sensor. Avoid exposing the Gasenz gas analyzer such as H₂S and hydrocarbons as this may shorten the life of the sensor and also lead to inaccurate measurements.

1.4 Specification

Supply	
Input Voltage Options:	85-264VAC . Option of 24 VDC Only.
Supply current:	140 mA at 24VDC nominal , all relays energised, 20 mA drawn on current loop. +30mA for integral Sounder Beacon
Outputs	
Analogue Output:	4-20mA analogue output (10-bit resolution)
Sensor Input	
No of Channels:	1
Sensor	%Vol oxygen 0-25% Zirconia. (Replacement 02-444)
Relays	
#1 or 2 (For user connection)	Single pole change over. Rating 6 Amps 250 v AC
Fuses	
Fuse	500mA anti-surge on board fuse for circuit protection.
Additional Features	
Display:	4 Digit, 7 Segment Display.
Keypad:	4-Button Keypad
Status Indicator	Two-Lamp Light Tower with Sounder Red Lamp LED-Alarm (+ Sounder 80db@0.3Mtr) Green Lamp LED-Normal/Ready



1.5 Status Indicator

A Two- Lamp High Intensity LED Light Tower provides indication of Normal Operational/Ready status or condition (Green) and Alarm condition (Red). The Alarm condition is triggered by a pre-settable gas measurement level being reached. At the same time as the Red lamp is illuminated, the Sounder also operates providing the user with both audible and visual indication of the alarm condition.

(For setting alarm levels-see page 24)

The Light Tower can be pre-wired for High and Low O₂ indication or for Low O₂ indication only.

Typical Operational Settings:

High O₂=23% rising alarm.

Low O₂= 19% falling alarm.

If High and Low level alarm functionality is required then only One user interface relay is available for external connection by the user.

If Low level alarm functionality only is required, then Two user interface relays remain available for the user to connect to.

Note: The Gasenz will be supplied configured with standard alarm level settings unless otherwise requested by the user.

For details of standard settings and other options please see the alarm and Relay configuration section within this manual.

2 PHYSICAL DATA

2.1 Mounting and Dimensions

Fig.1 shows the overall dimensions of the Gasenz.

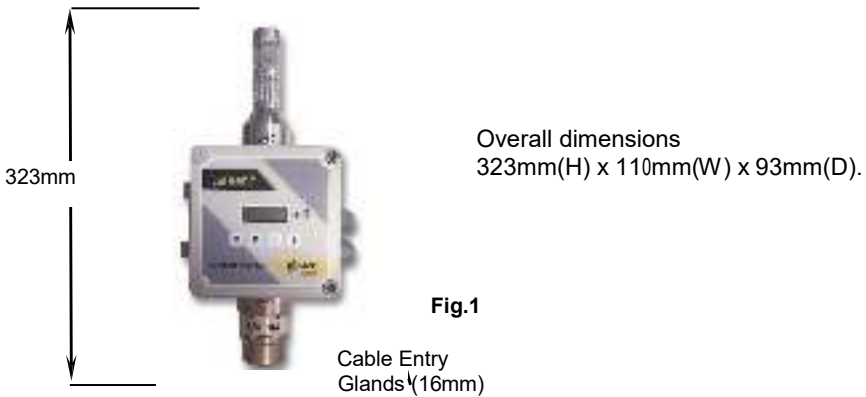

Mounting lugs-one per
corner

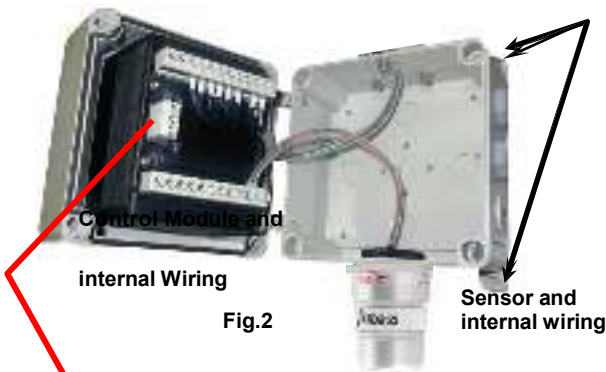

**85-264VAC supply Connection Terminal Strip. (This is for
24V on DC only models)**

2.1.1 Field Connections

All connections to the module are provided in the form of screw terminals. Access is gained by opening the Gasenz enclosure to reveal the terminal connector strips on the rear of the control module.

NOTE: Confirm the Voltage supply option of the Gasenz before connecting power.(24VDC or 85-264VAC)

Take care with Mains Voltage when Connecting and operating the Monitor. The Door should always be in the Closed position when operating.



See Fig's 3 and 4 on the following pages for user field connection wiring.

The User is to make all field connections in suitable cable to local regulation codes and taking into account the power requirements of the Gasenz as detailed in section 2 (Specification) of this manual.

2.1.2 Field Connections -DC Supply-Option. Fig.3

For customer use

See 2.1.1 page 5

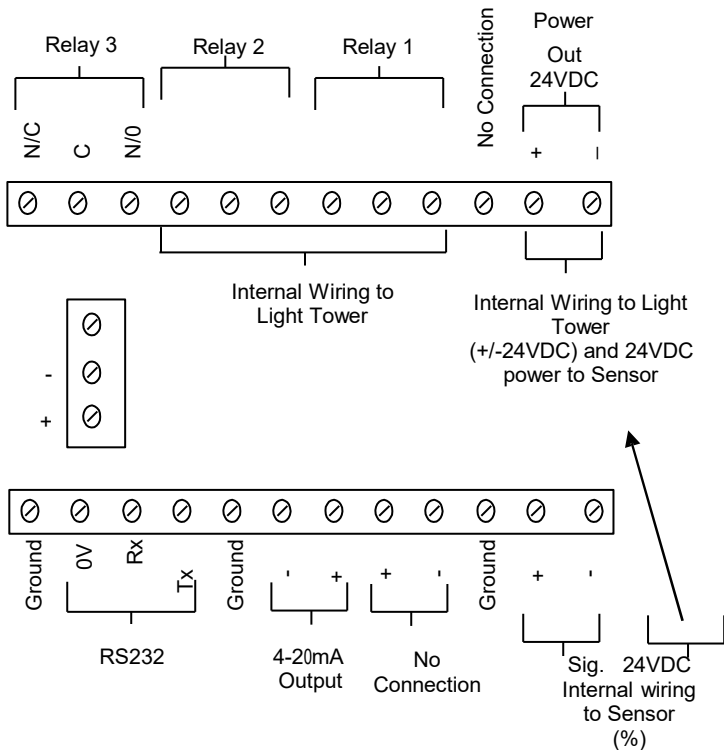

2.1.3 Field Connections –AC Supply-Option. Fig.4

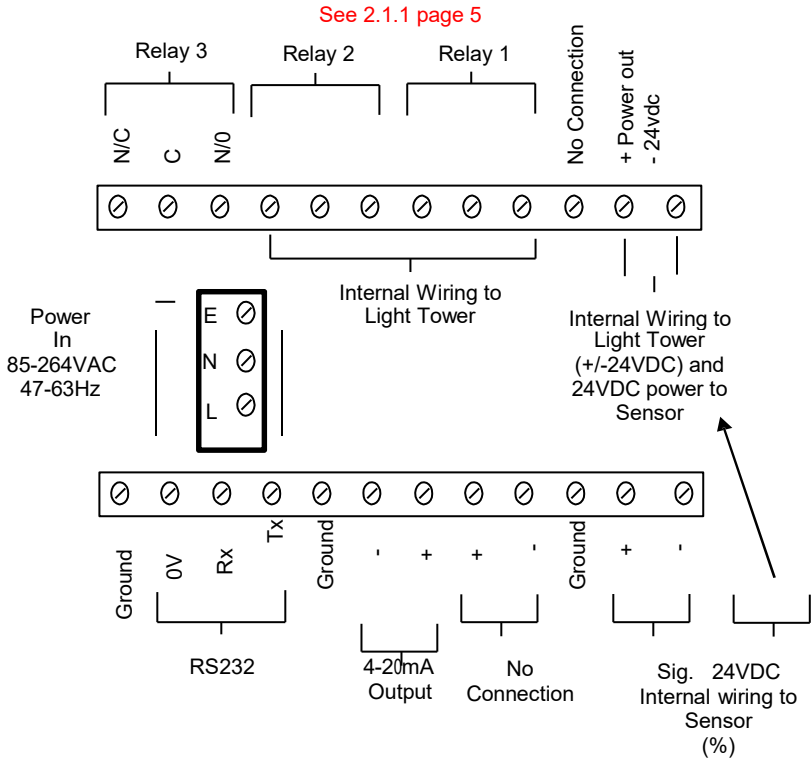



2.1.4 Mounting Locations

The Gasenz is a fixed gas detection system and should be installed so as to provide effective monitoring of a plant area where a low Oxygen level could occur. **It is a 'Safe Area' device** and is not suitable for locating in an area which requires an Ex rated device.

The Gasenz instrument should be located so as to be capable of giving an early warning of both the presence and location of an Oxygen deficient atmosphere.

The Alarm indication thus rendered by the Gasenz should be able to initiate the following actions as required:

- Safe Evacuation of location or Premises,
- Shut Down of process or plant.
- Ventilation Control.
- Appropriate Fire Fighting Procedures

In general, fixed systems should be installed so that maintenance of failure of one of the monitoring units does not compromise the safety of the location or premises being monitored. Duplication of Gasenz units may therefore be appropriate to maintain an adequate safety level.

Factors to take into consideration when choosing a location to mount the Gasenz are:

- Dimensions of location to be monitored
- Potential leak source
- Nature of gas to be detected
- Possibility of pressurized gas release/evaporation/Liquid leaks
- Confined spaces
- Air movements, ventilation, topography of location, temperature.
- Number of personnel in location.

The efficiency of the installed monitor is the customer's responsibility.

2.1.5 Location conditions

Ambient temperature range -20 to +40 degrees C

Background gases to avoid: Halogens, F, Cl, Br, SO_x, H₂S, vapours of Silicon sealing compounds, adhesives.

The Gasenz instrument has an IP65 environmental rating and is designed for indoor use only and is not to be exposed to weather elements.

The Gasenz instrument should be mounted on a vertical surface or wall with the sensor pointing downwards. The densities of gases with respect to air is given in European standard EN 617791:2000. It should be noted that high pressure gas leaks can result in a drop in gas temperature and subsequent temporary increase in gas density. In general, Gas monitors should be installed close to any potential leak source but not so close that they respond to equipment which may produce inconsequential leakage.

A well designed ventilation system should result in a number of air changes per hour and thus limit the potential for a gas build up or depleted Oxygen environment from developing.

A gas monitor, as a general rule, can cover an area of around 50M². All applications are different and require careful consideration before determining the number and location of gas monitors.

The 50M² rule equates to approximately a radius of 5M around the gas monitor. If the gas monitor is mounted on a wall, the operational area is effectively halved. (See illustrations below)

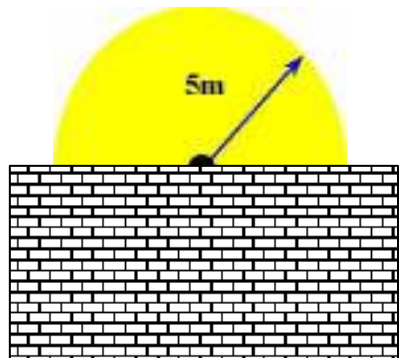



2.1.6 Analogue Output

The analogue output provides a means of indicating to external equipment (e.g. data loggers, remote displays) the gas levels currently being detected by the system. The output is that of a Current Source (4-20mA), where 4mA represents zero gas and 20mA represents gas at the sensor FSD.

3 SOFTWARE FEATURES

The menu system featured within the Gasenz allows all calibration and configuration activities to be performed.

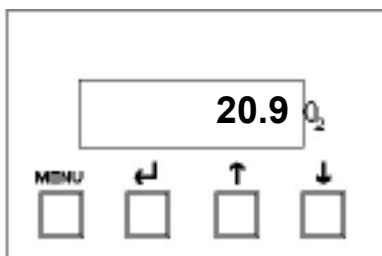

The keypad has the following functionality:

Button	Function	Alternate Function
A	Menu Open/Close	
B	Enter	Numerical value of 1
C	Next (Increment)	Numerical value of 2
D	Previous (Decrement)	Numerical value of 3

3.1.1 Password

The Gasenz Analyser uses a password system to restrict the end user from carrying out certain changes that may compromise the use of the equipment. The Password feature may be Enabled or disabled.

Menu access is organised in three levels, 1, 2 and 3.

Each of the three menu levels allows access to specific menu options within the menu system.

When a particular menu level is accessed, the user has 10 seconds to enter a specific menu within that level otherwise the menu level is automatically exited. Once a menu is entered, the user then has a duration of 10 minutes within that menu to make adjustments. When the adjustment is made, the menu is exited to save the adjusted setting to the analyser memory.

The menu structure and Password system is explained on the following pages.

Menu options

Menu option	Function
E:1	Calibrate Sensor
E:2	Analogue output FSD
E:3	Set 4 mA
E:4	Set 20 mA
E:5	Analogue Output Simulation
E:6	Factory Restore
E:8	Diagnostics
E:9*	Sensor type. (Factory Only)
E:11**	PPM Sensor Gain
E:12**	% Vol Sensor Gain
E:13**	Sensor Damping
E:14***	New Sensor Data
E:15**	Electronic Zero
E:16**	Noise Rejection
E:17	Relay
E:18	Alarm Levels
E:19	Alarm Hysteresis
E:20	Password Enable/Disable

*This Menu is protected by an additional factory Password and is not for use by the end user.

** These menus should not be accessed or changed by the user. Note: there is no Menu 10.

*** User access to this menu not necessary for Zirconia Sensors.

To access the Menus, first press the **MENU** button on the Analyser keypad. The Analyser display will flash with the word **PASS**. Enter the Password depending on the menu access required. The numerical Passwords are to be entered by using the keypad buttons as identified on the previous page. (e.g. for numerical password 1331, press button 'B' then button 'D' twice, then button 'B' again.) Note that for access to the Level 1 menus, no password entry is required. Next, press the MENU button again and press the **UP** arrow button to advance through the menu levels.

Menu Structure

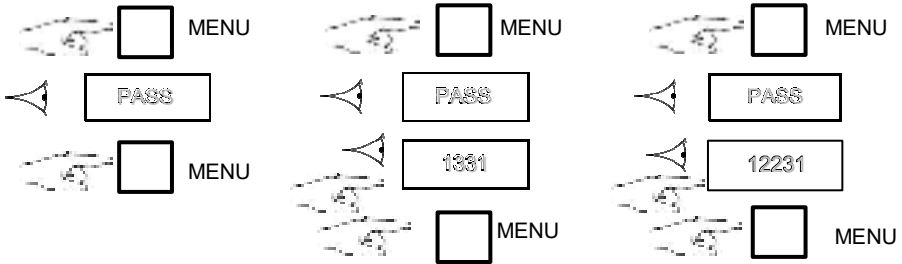

Level 1
Password
None
Menu
E:5
E:8
E:17
E:18
E:19

Level 2
Password
1331
Menu
E:3
E:4
E:5
E:8
E:17
E:18
E:19

Level 3
Password
12231
Menu
E:1
E:2
E:3
E:4
E:5
E:6
E:8
E:9*
E:11
E:12
E:13
E:14
E:15
E:16
E:17
E:18

*E:9-Password protected, Factory only; 'Greyed out' menus should not be accessed.



1.1.2 Menu 1 – calibrate sensor

For Zirconia sensor instruments, a calibration is not normally required as the sensor technology is of the non-consumptive type and operation is very stable. The user may wish to perform a periodic check of the accuracy of the Gasenz display reading by checking the environment being measured with a calibrated portable instrument and comparing this to the Gasenz reading. If it is determined that a calibration is required then this can be performed in ambient atmosphere after verification that said atmosphere is @20.9% Oxygen.

- Press the MENU button to open the menu system.
- Using the NEXT and PREVIOUS buttons select menu option: **E:1**
- Press ENTER.
- Allow time for sensor to respond/stabilise.
- Using the INC and DEC buttons set the reading to that of the calibration gas level.
- Press ENTER to span the sensor, '- - -' will be displayed to confirm the sensor span has been performed.
Note: Pressing the MENU button rather than the ENTER button exits the span feature without performing the calibration.
Wait until the reading is stable, if not press the ENTER button to span the sensor.
- Press the MENU button to close the menu system.
Note: The sensor span setting will be displayed (as a percentage value) on exit while the MENU key is pressed. Note that this value is a percentage of the initial calibration value set via "New Sensor Data" in menu E:14. See note below.

1.1.1 Menu 2 – Analogue output FSD

- Press the MENU button to open the menu system.
- Using the NEXT and PREVIOUS buttons select menu option:
E:2
- Press ENTER.
- Using the INCREASE and DECREASE buttons adjust the FSD to the required level.
- Press ENTER.
Note: Pressing the MENU button rather than the ENTER button exits the sensor FSD feature without any change.
- Press the MENU button to close the menu system.
Note: The Sensor FSD will be displayed on exit while the MENU key is pressed.

1.1.4 Menu 1 – Set 4 mA output

- Monitor the current sourced from the analogue output of the OEM module using a multimeter set to read milliamps.
- Press the MENU button to open the menu system.
- Using the NEXT and PREVIOUS buttons select menu option:
E:1
- Press ENTER.
- Using the INCREASE and DECREASE buttons adjust the output to 4mA .
- Press ENTER.
Note: Pressing the MENU button rather than the ENTER button exits the 4 mA feature without performing the calibration.
- Press the MENU button to close the menu system.
Note: The 4 mA factor will be displayed on exit.

1.1.5 Menu 4 – Set 20 mA output

- Monitor the current sourced from the analogue output of the OEM module using a multimeter set to read milliamps.
- Press the MENU button to open the menu system.
- Using the NEXT and PREVIOUS buttons select menu option: **E:4**
- Press ENTER.
- Using the INCREASE and DECREASE buttons adjust the output to 20 mA.
- Press ENTER.
- Press the MENU button to close the menu system.
Note: The 20 mA factor will be displayed on exit.

1.1.6 Menu 5 – Analogue Output Simulation

The Gasnz analogue output can be tested for functionality via menu 5. This option allows the user to simulate the analogue output.

- Press the MENU button to open the menu system.
- Using the NEXT and PREVIOUS buttons select menu option: **E:5.**
- Use the UP and DOWN button to increase or decrease the analogue output. The value displayed on the Microx display will be equivalent to the analogue output.
- Press the MENU button to close the menu system.
Note: The module will return to the conditions on entry.

1.1.7 Menu 6 – Factory Restore

This option allows the user to restore the configuration data to the factory default values.

Warning

A restore will overwrite all previous calibration data for the selected sensor excluding those set at the factory.

- Press the MENU button to open the menu system.
- Using the NEXT and PREVIOUS buttons select menu option:
E:6
- Press ENTER button. Hold for 5 or 6 seconds.
- When - - - - is displayed, release the ENTER button.
Note: Pressing the MENU button rather than the ENTER button exits the restore feature without performing any change.
- Press the MENU button to close the menu system.

1.1.8 Menu 8 • Diagnostics

This feature is a view-only feature. No configuration changes are possible from within this menu.

- Press the MENU button to open the menu system.
- Using the NEXT and PREVIOUS buttons select menu option:
E:8
- Press ENTER.
- The display will alternate between the current value and diagnostic code **E:8x**: where x is:
 - 0 Sensor signal, A to D counts low ppm range. N/A
 - 1 Sensor signal, A to D counts high ppm range. N/A
 - 2 Sensor signal, A to D counts %vol range.
 - 3 Firmware version.
- The diagnostic code can be selected by pressing the UP button.
- Press MENU to return the instrument to its standard mode of operation.
- Press MENU to close the menu system.
Note: The signal gain setting will be displayed on exit while the MENU key is pressed.



1.1.9 Menu 17 – Relay

Note: Changing these settings (and those in Menu 18) will alter the operating point of the Indicator unit and Relays and as such may affect the capability of the unit to announce a dangerous Oxygen Level to the user. Be sure you understand the intended effects of your intervention into these Menus.

Relay 1 or 1 and 2 are configured and wired for operation of the Light Tower indication unit and when so used, are not available for use by the user. Relays not used to operate the Light Tower are available for user connection. Relay 3 (and Relay 2 if available) are volt free contacts, 6A @ 250VAC rated.

The unit is fitted with three relays that are operated in conjunction with one of three alarm levels.

Relay 1 is associated with alarm level 1.

Relay 2 is associated with alarm level 2.

Relay 3 is associated with alarm level 3.

The user can select if the relay is normally Energized, 'E' or normally de-energised, 'd' when the unit is **not** in an alarm condition. The relay can also be set to act on rising, 'r' or falling 'F' gas levels.

This option allows the user to configure the operation of the relays.

- Press MENU to open the menu system.
 - Using the NEXT and PREVIOUS buttons, select menu option: **E:17**
 - Press ENTER. The display displays r:1
 - Use the UP | DOWN keys to select the desired relay.
 - The display will show the following:
E:r Normally energized, rising alarm
d:r Normally de-energized, rising alarm
E:F Normally energized, falling alarm
d:F Normally de-energized, falling alarm
 - The mode of operation can be changed by pressing the UP button.
 - Press ENTER to store the new data in the memory.
- Note: Pressing the MENU button rather than the ENTER button exits without any change.*
- Press MENU to close the menu system.



1.1.10 Menu 18 – Alarm levels

Relay's 1 and 2 alarm levels are factory configured for 19% Vol. O₂ falling (relay 1) and 21% Vol. O₂ Rising (relay 2). Relay 1 is set at 25% rising by default.

19.5% is the OSHA recognised US lower Alarm level for O₂ depletion. Some users may wish to follow this regulatory body in the application of this and other alarm level settings.

This option allows the user to set the operation of the alarm levels. There are three alarms levels associated with 3 relays.

Alarm level 1 is associated with relay 1.

Alarm level 2 is associated with relay 2.

Alarm level 3 is associated with relay 3.

- Press MENU to open the menu system.
- Using the NEXT and PREVIOUS buttons, select menu option: **E:18**
- Press ENTER. The display displays A:1
- Use the UP | DOWN keys to select the desired alarm level.
- Press ENTER. The display shows the alarm level.
- Use the UP | DOWN keys to set the desired alarm level.
- Press ENTER to store the new value in the memory.
Note: Pressing the MENU button rather than the ENTER button exits without any change.
- Press MENU to close the menu system.

1.1.11 Menu 19 – Alarm hysteresis

The unit has a hysteresis value associated with the alarm levels to avoid relay chattering as the unit goes in and out of alarm conditions.

The hysteresis value is expressed as a percentage of the alarm set point and takes a value of between 0 and 10. **Warning Note:**
Setting to •1 disables the Relays.

- Press MENU to open the menu system.
- Using the NEXT and PREVIOUS buttons, select menu option:
E:19
- Press ENTER. The display shows the hysteresis level.
- Use the UP | DOWN keys to set the desired level.
- Press ENTER to store the new value in the memory.
Note: Pressing the MENU button rather than the ENTER button exits without any change.
- Press MENU to close the menu system.

1.1.12 Menu 20

The Password function can be enabled or disabled in this Menu.

- Press MENU to open the menu system.
- Using the NEXT and PREVIOUS buttons, select menu option:
E:20
- Press ENTER. The display shows the current status **On** or **Off**
- Use the UP | DOWN keys to set the desired status **On** or **Off**.
- Press ENTER to store the new value in the memory.
Note: Pressing the MENU button rather than the ENTER button exits without any change.
- Press MENU to close the menu system.





4 ROUTINE MAINTENANCE & SERVICING

The Gasenz will provide reliable and fault free service for many years if cared for correctly.

Routine Inspection and Maintenance

It is advisable to periodically inspect the Gasenz installation:

Clean gas detector head using a clean DAMP cloth.

Inspect the sensor and ensure it is sound and the sensor-housing aperture is not obstructed (where applicable).

The maximum time interval between routine inspections should be assessed by the calibrating personnel and will depend upon the environment in which the equipment is installed.

Warnings

The Sensor is heated internally as part of its operation.

The Sensor can be damaged if moisture is allowed to condense onto the sensor element when the Gasenz is not powered. On powering up, the evaporation of the moisture has a rapid cooling effect on the sensor element which can irreversibly damage the sensor. When powered up, condensation of moisture will not occur but wetting of the sensor by water or other liquid can likewise damage the sensor.

Replacement of Sensor

The stated life of the Oxygen sensor is between 3 to 5 years depending on application conditions. When the Gasenz cannot be calibrated, this may indicate that there is a problem with the sensor or that the sensor life has expired, The Analyser should be returned to Ntron for Sensor replacement.



User Notes:



contact Ntron at:

**Mullaghboy Industrial Park,
Navan, county Meath,
Ireland.**

Pn.: 00151(0)46 9071111

Fx.: 00151(0)46 9071111

E•mail: info@ntron.com

Web.: www.ntron.com