



The Gasenz Oxygen Monitor is designed for the monitoring of oxygen deficient atmospheres in any work area where the risk of asphyxiation may occur due to the presence of gases like nitrogen or carbon dioxide.

This compact and rugged % zirconia oxide or electrochemical sensor oxygen monitor is perfectly suited for personnel protection in the gas generation industry and in hypoxic fire prevention systems.

## Applications

- » Gas generation (oxygen / nitrogen)
- » Pharmaceutical industries
- » Process industries
- » Food & Beverage industries
- » Hypoxic Fire Prevention Systems

## Features

- » Long life, low maintenance zirconia or electrochemical sensor technology
- » Measurement range: 0 to 25% O<sub>2</sub>
- » Compact ambient oxygen monitor
- » Audio/ visual alarm indicator
- » LCD + 4 button multifunction keypad
- » Simple Installation (only power lead required)

**Plug & Play  
Technology**

### Proven sensor technology

With a choice of either zirconia or electrochemical sensor technology the Gasenz offers reliability, accuracy and flexibility. Both technologies have a broad measurement capability allowing the user to measure from selected ranges from 1ppm to 96% oxygen.

### Zirconia sensor

The Ntron zirconia oxygen sensor is a non-depleting zirconia solid electrolyte sensor. A small capillary on the sensor controls the diffusion of oxygen into the sensor. When heated to over 400°C oxygen is electronically reduced causing current flow through the zirconia electrolyte. Zirconium-oxide allows the movement of oxygen ions through the substrate from a high to a low concentration. The measurement of oxygen is determined by the current flowing through the electrodes. The zirconia sensor has an unlimited shelf life without the loss of calibration and has an expected life in excess of 5 years. The zirconia sensor is not position sensitive and has low cross sensitivity to other gases and does not dry out.

### Low maintenance and cost of ownership

Due to the highly stable nature of the sensor, a calibration interval of once per year is required, allowing for significant cost savings. The construction of our zirconia oxygen sensor means that only 100 mL/min of sample gas is required, providing application flexibility and further potential cost savings.

### Fast response time

Zirconia oxygen sensors respond very quickly to oxygen concentrations in both directions with a T90 of less than 10 seconds within a set range.

### Electrochemical sensor

The key elements of the electrochemical sensors are a membrane, cathode, anode, electrolyte and measurement circuit. The sensing membrane (covering the cathode) is made of PTFE and is mounted over a metal perforated electrode. The space between the membrane and the electrode is filled either with an aqueous alkaline or an acid electrolyte. In normal operation, all portions of the anode and cathode are immersed in the electrolyte. As oxygen diffuses through the membrane into the electrolyte it causes a reaction between the cathode and anode generating an EMF. This current is proportional to the amount of oxygen present in the sample gas. In the absence of oxygen there is no output from the electrochemical sensor, meaning only one calibration is required.

### Sensor construction

The main body of the sensor is fabricated from high density PVDF. The supporting ring at the face of the sensor is constructed of stainless steel. This results in an oxygen sensor that is chemically resistant to most sampling atmospheres and can be used with trace solvents and hydrocarbons present in the sample gas, unlike zirconia (due to the high temperature of the sensor).

### Installation flexibility

Designed for the ambient detection of low Oxygen concentration with ease of installation.

## Application Setup

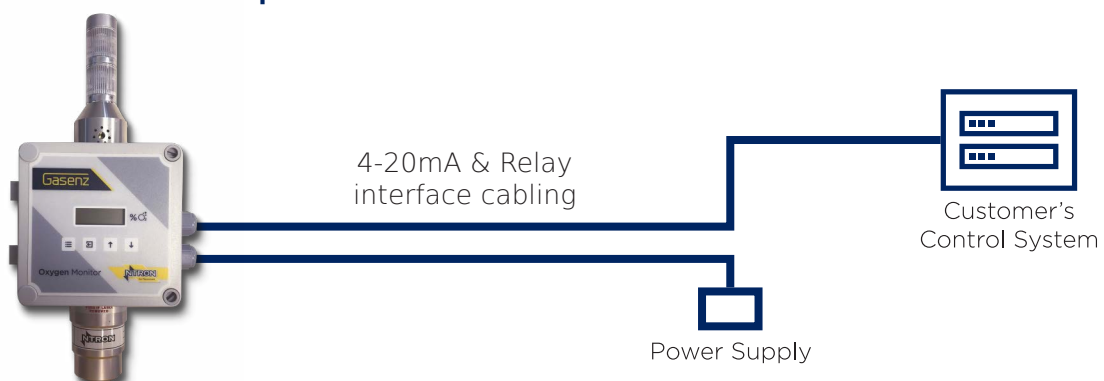

<b>Performance</b>		
<b>Transmitter Model</b>	<b>Gasenz</b>	
Measurement technology	Zirconia (ZR)	Electrochemical (EC)
Measurement range	0 to 25%	
Output resolution ( for %)	0.01%	
Accuracy	±1% of range	
Response time (T90)	<10 seconds	
LDL (Sensitivity)	0.01%	
Temperature range	-20°C to +50°C	0°C to +45°C
Pressure range	900 to 1100 mBar <sub>abs</sub>	
Linearity	1% of range	
Life expectation	3-5 years	1 year
Humidity	0-95% RH non-condensing	
Shelf life	No shelf life	Up to 6 months
<b>Electrical Input / Output</b>		
Power supply	100-240 VAC	24 VDC
Power consumption	Maximum load 160mA	
Signal output	4-20mA current loop powered	
Digital communications	RS232	
Digital output options	1 off relay, dry contact 5 Amp rated (2 relay outputs assigned to control light tower indicator)	
Display format	% O <sub>2</sub>	
Visual indicators	LCD, audio and visual alarm indication	
<b>Mechanical Specifications</b>		
Dimensions	145mm (h) x 110mm (w) x 93mm (d) incl. cable glands	
Weight	Approx 250g	
Wetted materials	Stainless steel	
Mounting	Wall	
Ingress protection	IP65 enclosure	
Housing material	ABS	
<b>Certification</b>		
Complies with EMC Directive 2004 / 108 / EC. UL/ETL Certification Number: UL-61010-1		

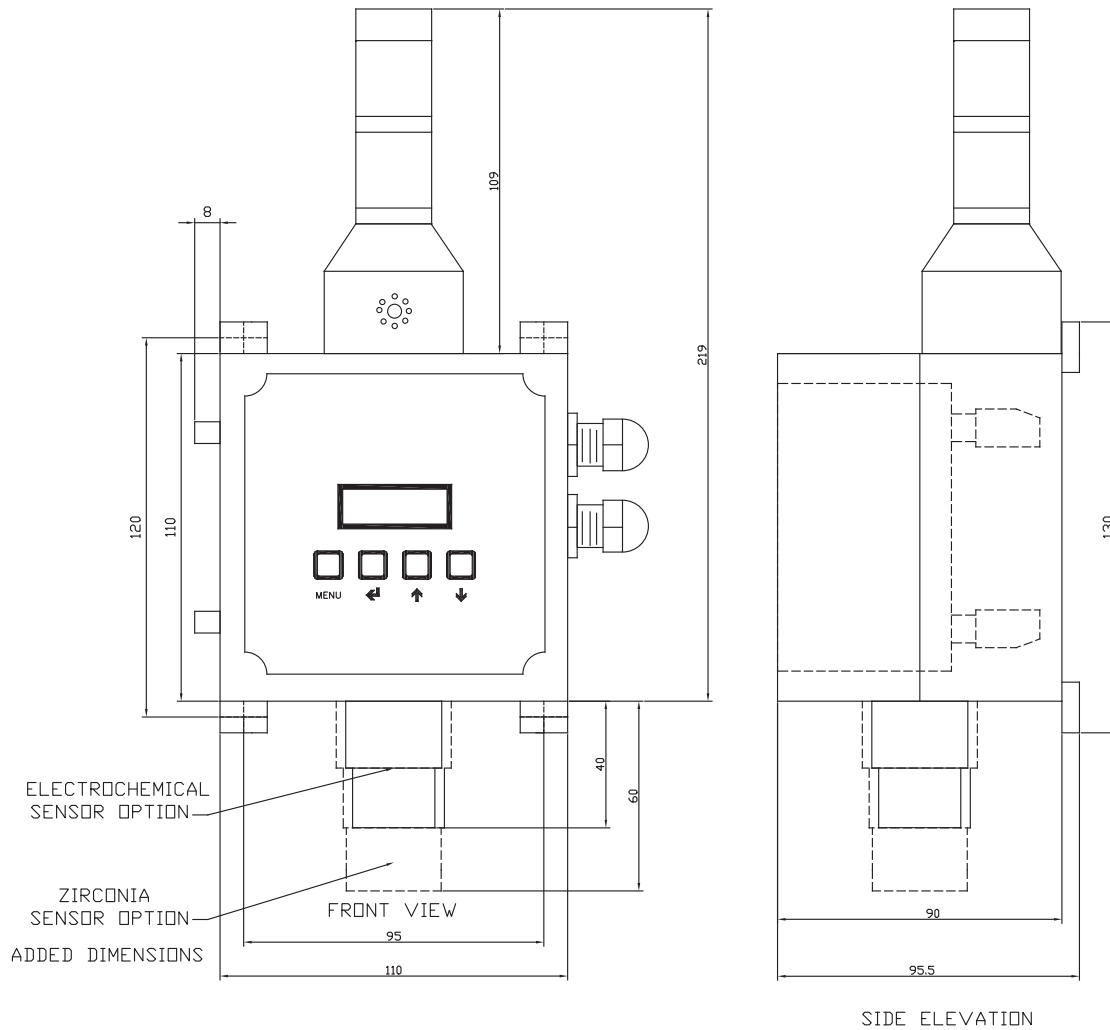

## Related Products



**SENZTX**  
Oxygen  
Transmitter



**SF82**  
Dew Point  
Transmitter



**Minox i**  
ATEX Rated  
O<sub>2</sub> Transmitter



**Microx-OL**  
Online Oxygen  
Analyser



**Microx**  
Oxygen  
Analyser



**Yellow Box**  
Portable O<sub>2</sub>  
Analyser



**GazTrak**  
Portable oxygen &  
moisture measurement