

Ultrasonic Pressurized Gas Leak Detector User Operation Manual



Model: NSM-SU343

ISO 9001:2000



MAN-0129 Rev 0.3
December 8, 2010

IMPORTANT INFORMATION

This manual is for informational purposes only. Although every effort has been made to ensure the correctness of the information, technical inaccuracies may occur and periodic changes may be made without notice. Net Safety Monitoring Inc., assumes no responsibility for any errors contained within this manual.

If the products or procedures are used for purposes other than as described in the manual, without receiving prior confirmation of validity or suitability, Net Safety Monitoring Inc., does not guarantee the results and assumes no obligation or liability. No part of this manual may be copied, disseminated or distributed without the express written consent of Net Safety Monitoring Inc.

Net Safety Monitoring Inc., products are carefully designed and manufactured from high quality components and can be expected to provide many years of trouble free service. Each product is thoroughly tested, inspected and calibrated prior to shipment. Failures can occur which are beyond the control of the manufacturer. Failures can be minimized by adhering to the operating and maintenance instructions herein. Where the absolute greatest of reliability is required, redundancy should be designed into the system.

WARRANTY

Net Safety Monitoring Inc warrants its electronic assemblies against defective parts and workmanship for a period of 18 months from date of purchase to 12 months from the date of commissioning, whichever is the shorter period. No other warranties or liability, expressed or implied, will be honored by Net Safety Monitoring Inc. Contact Net Safety Monitoring Inc. or an authorized representative for details.

We welcome your input at Net Safety Monitoring. If you have any comments please contact us at the phone/ address below or visit our website and complete our on-line customer survey: www.net-safety.com/

If further language translation for this manual is required please contact:

CONTACT INFORMATION

Net Safety Monitoring Inc.
Corporate Headquarters
2721 Hopewell Place NE
Calgary, AB Canada T1Y 7J7

Direct: (403) 219-0688
Facsimile: (403) 219-0694
E-mail: nsmsales@net-safety.com
Web-site: www.net-safety.com/

© Net Safety Monitoring, Inc. 2010. All rights reserved.

TABLE OF CONTENTS

1. Product Overview	4
1.1. Technical Specification	5
1.2. Design Standards	6
2. General Operation	7
2.1. Overall Dimensions.....	8
2.2. Electrical Connection Drawing	9
3. Installation / Commissioning / Maintenance	10
3.1. Installation Procedure	10
3.1.1. Mechanical Installation.....	10
3.1.2. Mechanical Positioning	11
3.1.3. Wall / Flat Surface Mounting	13
3.1.4. Pole Mounting.....	14
3.1.5. Vibration Mounting	15
3.1.6. Electrical Installation	17
3.2. Commissioning	21
3.2.1. Visual.....	21
3.2.2. Power up	22
3.2.3. User Changeable Functions Set-up	22
3.2.4. Function Check.....	26
3.3. Operating Principles / Instruction	26
3.3.1. Normal Operation	26
3.3.2. Alarm Level.....	27
3.3.3. Alarm Delay	28
3.3.4. Self-Test and Self-Clean	30
3.3.5. Heating (Optional).....	31
3.3.6. Output Options.....	32
3.4. Maintenance Procedures	39
3.4.1. Hand held Test	39
3.4.2. Verification Test	40
4. Customer Interface Commands	40
4.1. RS485 Digital Interface	40
4.1.1. Customer Commands	40
5. Warnings	43
5.1. Use in Hazardous Areas	43
5.2. Ownership & Confidentiality	44
5.3. Accessories	44
5.4. Liability.....	44
6. Accessories and Spare Parts	45
6.1. Accessories	45
6.2. Spare Parts.....	46
6.3. Ordering Information	47
6.4. Accessories	48
6.5. Spare Parts.....	48

1. PRODUCT OVERVIEW

NSM-SU343 is an ultrasonic gas leak detector for detecting airborne ultrasound generated from pressurized gas leaks.

Airborne ultrasound is generated when gas moves from a high-pressure area to a low pressure area with a ratio of 1.8:1 upstream to downstream, however, NSM-SU343 is only recommended for pressures down to 2 bar(29psi). The amount of airborne ultrasound generated is due to a number of factors including but not limited to gas pressure, leak size and gas temperature.

NSM-SU343 uses 4 individual piezo ceramic sensing heads. The sensor design makes the sensing heads virtually indestructible and totally immune to temperature, moisture and other contaminants found in hazardous industry.

NSM-SU343 has a large dynamic range which allows use in a large range of applications from laboratories to turbine houses. The multi-stage amplifier ensures a completely linear output across the entire detector range without drop-off at each end of range.

NSM-SU343 is not designed to detect specific gas types, LEL or ppm, but instead responds instantaneously to a wide range of leak sizes whilst being un-affected by even the most extreme weather conditions. NSM-SU343 is rated to IP66 / IP67 to withstand harsh environments and continues to work during temporary immersion.

NSM-SU343 uses a continuous background monitoring test feature alongside a broadband self-test and clean facility to ensure complete functionality. The broadband self-test comprises a pressurized air jet across both flat faces of the cylindrical piezo crystal so testing is confirmed using the medium of interest. The broadband self-test can be requested on demand from the main control system or programmed to activate at known intervals.

NSM-SU343 has an optional heating / cooling facility which enables the internal electronics to be kept within normal parameters even at ambient temperatures such as -55°C (-67°F) to +85°C (+185°F). Unlike most heating systems the NSM-SU343 has an ultra efficient heating system that reacts to the environment allowing minimal power usage.

NSM-SU343 has complete customer flexibility and can be configured to mimic existing forms of detector outputs and protocol featuring 4 – 20mA analogue output and RS485 digital interface.

NSM-SU343 also features infra-red communication which allows complete communication and setting ability from up to 8m (26ft) range using the NSM-SU343 handheld series of intelligent communicators.

NSM-SU343 handheld series allows users to map for ultrasound, test ultrasonic detectors using a powerful 40kHz sound source of 100dB at 1m (3ft), communicate and program the NSM-SU343 and communicate via Infra-red interface. See section 6 Accessories and Spare Parts or contact a Net Safety Monitoring representative for further details.

1.1. TECHNICAL SPECIFICATION

General

Detection method	Floating Piezo Ceramic – non consumable, non ageing.
Gases detected	All pressurised gases, minimum leak pressure 2 bar, leak size dependant
Self-test	Continuous background check and broadband pressurised gas release on demand or via customer defined cycle
Calibration	Factory set. Broadband self-test check requires no field calibration

Performance

Detection range	25kHz to 100kHz
Dynamic range	50dB to 140dB
Response time	Instantaneous (alarm delay via 1 second variable increments – customer programmable)
Detection coverage	2 to 40 meter (7 to 131 foot) radius (leak pressure, size and background level dependant)
Test frequency	>2Hz to <100kHz \pm 2kHz at defined frequencies
Test sound pressure	100dB \pm 4dB at sensor
Start-up time	Less than 20 seconds

Output Signal

4 – 20mA	Current source 4 – 20mA, corresponds to 40 to 200dB SPL – Maximum load resistance 500 Ω standard (options available)
Digital	RS485 interface
Option	Current sink 4 – 20mA
Relay 1	Error / Fault (NO or NC option) Load: 2A max. Switch Voltage 220VDC max. Indication resistance 70 milliohm. See Section 3.3.6.1 Relay Options for further configurations.
Relay 2	Alarm (NO or NC option)
Relay 3	Maintenance (Alert for next maintenance schedule – non urgent)

Detector Faults

0mA	No power or microprocessor fault
0.5mA	Over temperature fault
1.0mA	Watchdog fault, electronic test fault, high/low voltage fault.
2.0mA	Test Fault
2.5 to 3.0mA	Function Fault

Power

Supply	24V DC, range 15 – 30 V DC
Current Consumption	250mA normal operation 3A maximum at -55°C (-67°F) heated option
Cable entry	M20 x 2 Ex d cable gland (M25 x 2, 1/2" NPT x 2, 3/4 NPT x 2 or any combination option) M20 x 2 serial link option

Temperature Range

Storage	-40°C to +70°C (-40°F to +158°F)
Operating	-40°C to +85°C (-40°F to +185°F)
Operating option	-55°C to +85°C (-67°F to +185°F)
Humidity (operating)	0 to 100% relative humidity

Ingress Protection IP66 / IP67

Approvals

ATEX
Ⓔ Ex II 2 G Ex d ib IIB+H₂ T4 Gb (Tamb -55°C to +85°C)
ITS09ATEX16836X

IECEX
Ex d ib IIB+H₂ T4 Gb (Tamb -55°C to +85°C)
IECEX ITS 10.0004X

Enclosure

Stainless steel AISI 316.	Weight Approx. 8kg (17.5 lb)
Aluminium LM25TF BS1490.	Weight Approx. 6.5kg (14.3 lb)
Dimensions (without bracket)	Ø210 x 272mm (Ø8 1/4 " x 10 3/4 ")

1.2. DESIGN STANDARDS

IEC / EN60079-0:2009 Electrical apparatus for potentially explosive atmospheres – Part 0: General requirements

IEC/EN60079-1:2007 Electrical apparatus for potentially explosive atmospheres – Part 1: Equipment protection by flameproof enclosures “d”

EN60079-11:2007 Electrical apparatus for potentially explosive atmospheres – Part 11: Equipment protection by intrinsic safety “i”

EN60529:1992 Specification for degrees of protection provided by enclosures (IP code)

2. GENERAL OPERATION

NSM-SU343 is omni-directional and is recommended to be mounted between 3 to 5 meters (10 to 16 feet) above the area of interest to eliminate ground absorption and reflections.

It is recommended that the area where the NSM-SU343 is to be situated is ultrasonically mapped prior to installation or at commissioning whilst all process is running to establish a background noise level for alarm purposes. Alarm level should be set 6dB above the background noise level at levels below 70dB and then the value above background shown in the alarm level graph in section 3.3.2 Alarm Level. Please contact a Net Safety Monitoring representative to request a mapping survey or mapping tools.

NSM-SU343 responds to pressurized gas leaks or sources of ultrasonic noise between 25kHz and 100kHz instantaneously, it is, therefore, recommended that a time delay is built in to the control system or internally in the NSM-SU343 to prevent spurious alarms. This is especially important in areas with pressure relief valves or areas of high human involvement or maintenance work. The alarm delay is recommended at a minimum of 10 seconds but this should be increased in response to the process located near to the detector as shown in the graph in section 3.3.3 Alarm Delay.

Area monitored by NSM-SU343 is affected by several factors such as background noise level, gas pressure, leak size, temperature of gas and environmental conditions. Net Safety Monitoring has formulated a series of calculations and built up a database of detection radius using gas leak testing to determine accurate coverage information for most situations. Please contact Net Safety Monitoring or a Net Safety Monitoring representative to advise on appropriate coverage for each installation.

NSM-SU343 detection coverage can be verified at installation or as part of a maintenance schedule using the NSM-PTV Performance Target Verification Kit to simulate an actual gas release of known size and pressure at the perimeter of the NSM-SU343 detection radius. See section 6 Accessories and Spare Parts or contact a Net Safety Monitoring representative for further details.

Compared to other Ultrasonic and traditional forms of detection, the NSM-SU343 has the following advantages:

- Presence of gas is not required
- Unaffected by weather conditions
- Sensors are unaffected by temperature, pressure, moisture and contaminant build-up
- Multiple sensor redundancy in each unit
- Continuous and forced self-test function
- Self-clean function
- No calibration required results in cost saving over detector life cycle
- Can be remotely tested from up to 8m (26ft) distance saving on maintenance scaffold costs
- Can be remotely programmed from control room or 8m (26ft) distance using handheld communicator
- Can be programmed to mimic any detector inputs to suit existing control system
- Can be set-up to act as a standalone unit
- Multiple Detectors can be linked together to save control system I/O

2.1. OVERALL DIMENSIONS

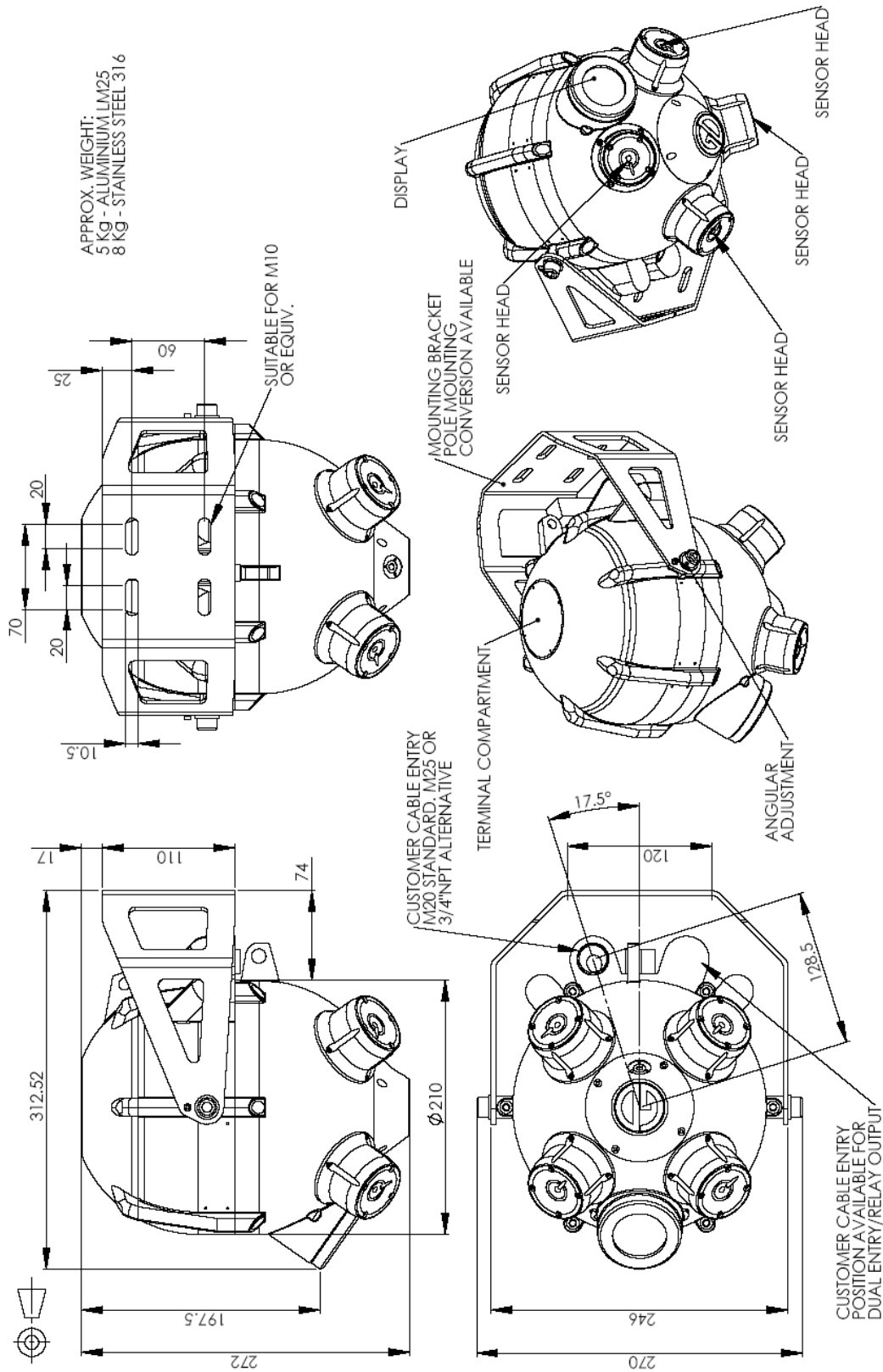

2.2. ELECTRICAL CONNECTION DRAWING

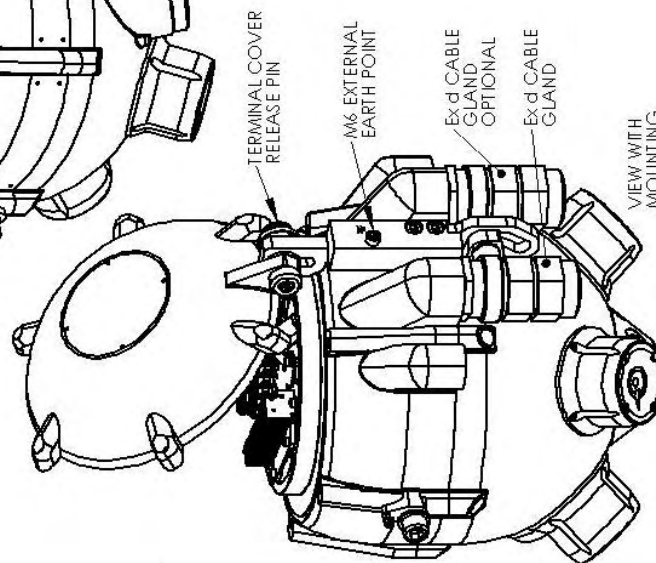
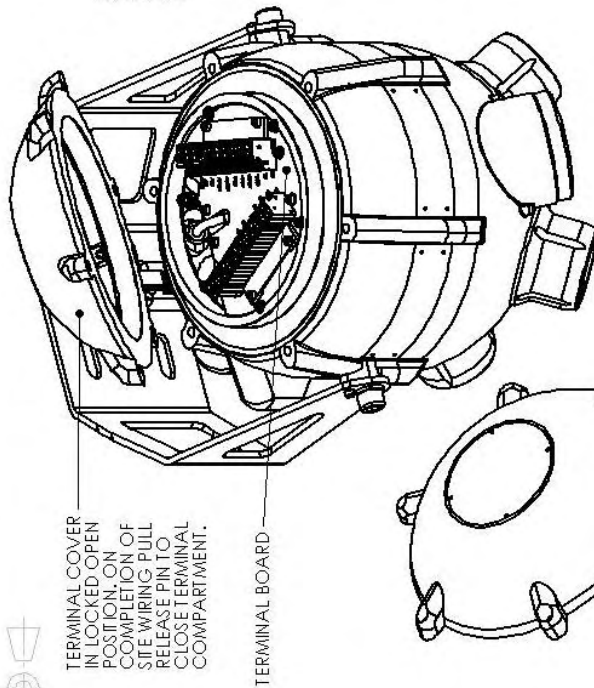
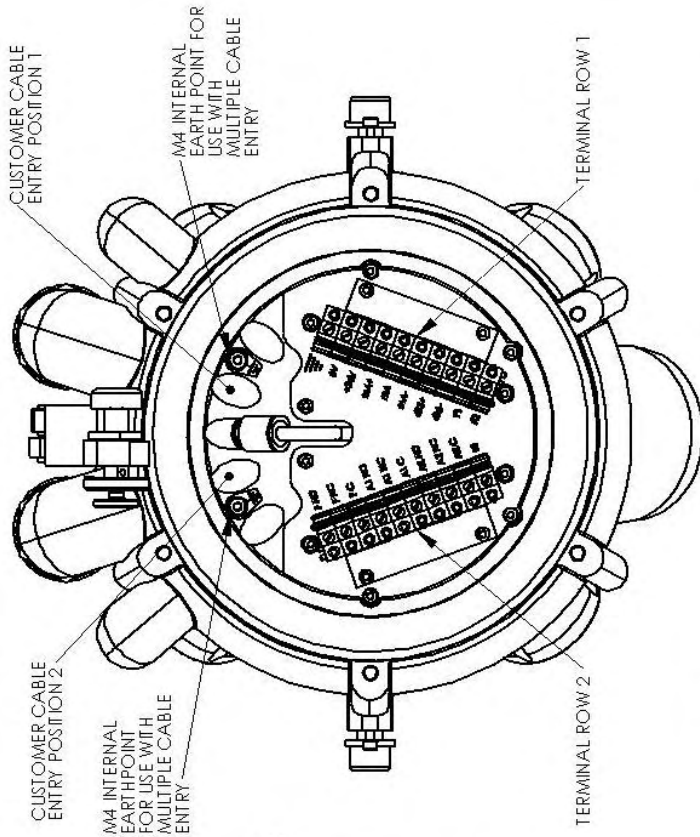

	TERMINAL ROW 2	TERMINAL ROW 1
F NO	FAULT RELAY NORMALLY OPEN	SINGLE CABLE ENTRY INTERNAL EARTH
F NC	FAULT RELAY NORMALLY CLOSED	24V RETURN - (0V)
F C	FAULT RELAY CIRCUIT CONTACT	+24VDC (15 to 30 VDC)
A1 NO	ALARM 1 NORMALLY OPEN	mA +
A1 NC	ALARM 1 NORMALLY CLOSED	mA
A1 C	ALARM 1 CIRCUIT CONTACT	4 - 20 mA OUTPUT
A2 NO	ALARM 2 NORMALLY OPEN	mA -
A2 NC	ALARM 2 NORMALLY CLOSED	RS485 + (EIA 485)
A2 C	ALARM 2 CIRCUIT CONTACT	RS485 - (EIA 485)
F3	FACTORY USE ONLY	F1
		F2
		FACTORY USE ONLY

3. INSTALLATION / COMMISSIONING / MAINTENANCE



Warnings:

The area in which the detector may be mounted must be in accordance with the certification of the apparatus and in accordance with the standards of the appropriate authority in the country concerned.

Do not modify the enclosure or component parts as this will compromise the Hazardous Area Certification.

Ensure all wiring and power supply to the detector is within specified operating parameters.

NSM-SU343 is a sealed unit with the exception of the terminal cover; the main enclosure is not to be opened by anybody other than Net Safety Monitoring or Net Safety Monitoring authorized personnel. All warranties and certification are nullified if these seals are broken or tampered with.

NSM-SU343 is supplied without cable glands. Ensure all cable entry threads are sealed with an appropriate plug to eliminate water ingress and thread damage. At installation all shipping cable entry plugs are to be removed and replaced with suitably approved Ex d cable glands or plugs.

3.1. INSTALLATION PROCEDURE

Mounting height of NSM-SU343 is recommended between 3 and 5 meters (10 and 16 feet) above floor level to eliminate ground reflections and absorption. NSM-SU343 may be used lower than 3 meters (10 feet) but coverage may be reduced, please contact Net Safety Monitoring or a Net Safety Monitoring representative for details.

It is recommended that all identification tags are firmly secured to prevent unwanted locally generated ultrasonic noise.

Observe the area of installation for equipment capable of generating high levels of spurious airborne noise that would not be classified as normal background noise such as pressure release valves, helipads, sirens etc. If any are present in the detector range of coverage please contact Net Safety Monitoring or monitor detector when activated to ensure immunity.

3.1.1. MECHANICAL INSTALLATION

NSM-SU343 incorporates a dedicated flameproof terminal compartment certified to Ex d, a flameproof main electronics compartment certified to Ex d, and a pump compartment which contains no electrical devices, all are sealed to IP66/IP67.

NSM-SU343 has a large detection radius capability and care should be taken when positioning to utilize the maximum detector coverage and eliminate blind spots and spurious alarms.

NSM-SU343 has a variety of fixing options to incorporate installation into most situations found in industrial environments such as wall / flat surface (section 3.1.3), vertical / horizontal pole (section 3.1.4) and vibrating surfaces (section 3.1.5). If fixing is required to mount the detector into a position which falls outside of the scope of the standard mounting options please contact a Net Safety Monitoring representative for details of specialist design service.

NSM-SU343 can be mounted in any orientation but care should be taken to position the display facing an area with ease of access to allow the information to be viewed. **Note:** The infra-red send and receive ports are located above the display, if remote programming is required then care should be taken that line of sight to the display can easily be achieved up to a maximum distance of 8m (26ft).

3.1.2. MECHANICAL POSITIONING

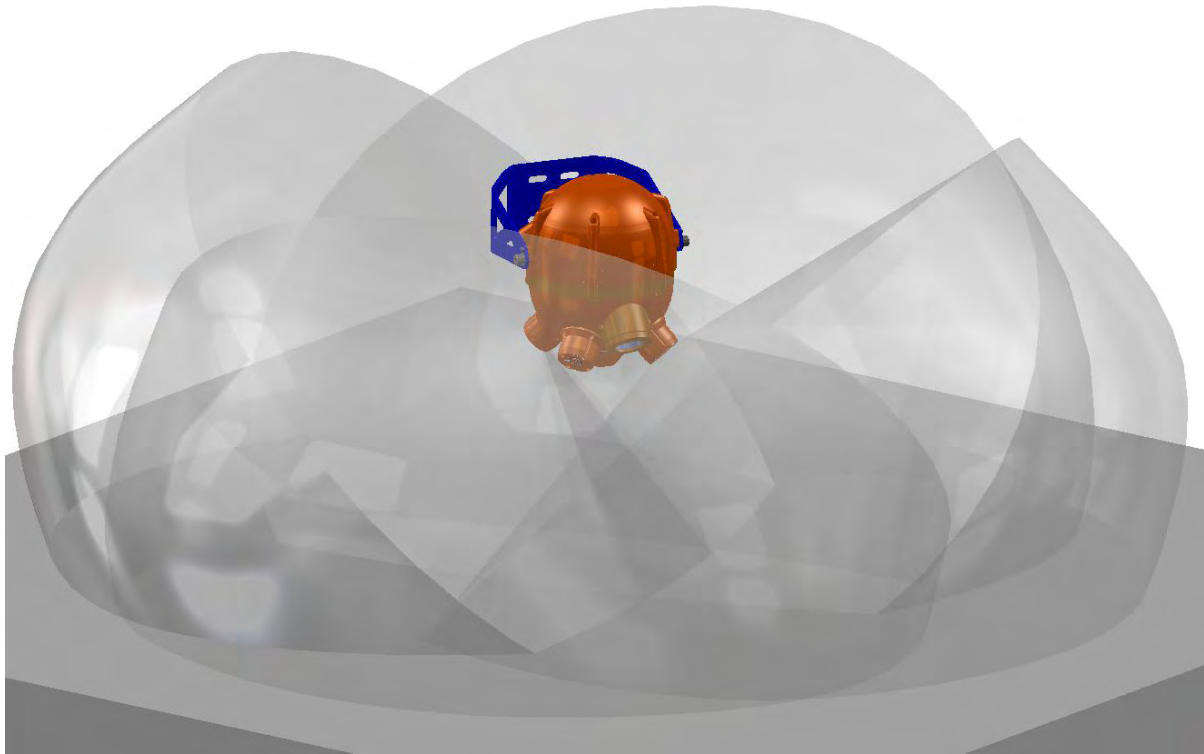

Figure 1

NSM-SU343 utilizes 4 independent sensors heads for full coverage. Figure 1 shows a 3D view of the coverage (detector not to scale) at a 3m (10ft) height above floor level with the detector pointing vertically downwards. NSM-SU343 coverage is specified as meters radius at the floor level as this is the minimum sensing distance. As shown the entire area below the detector is covered as well as some of the area above and around the detector. Each sensor overlaps the next so areas underneath the detector are covered by multiple sensors.

Note: The figure shows coverage stopping at 75° perpendicular from the sensor face, in reality it will decrease so the area above the detector will also have some limited coverage.

Figure 2 shows a 2D view of coverage when the detector is mounted vertically downwards and highlights that the radius coverage stated is the minimum area covered.



Figure 2

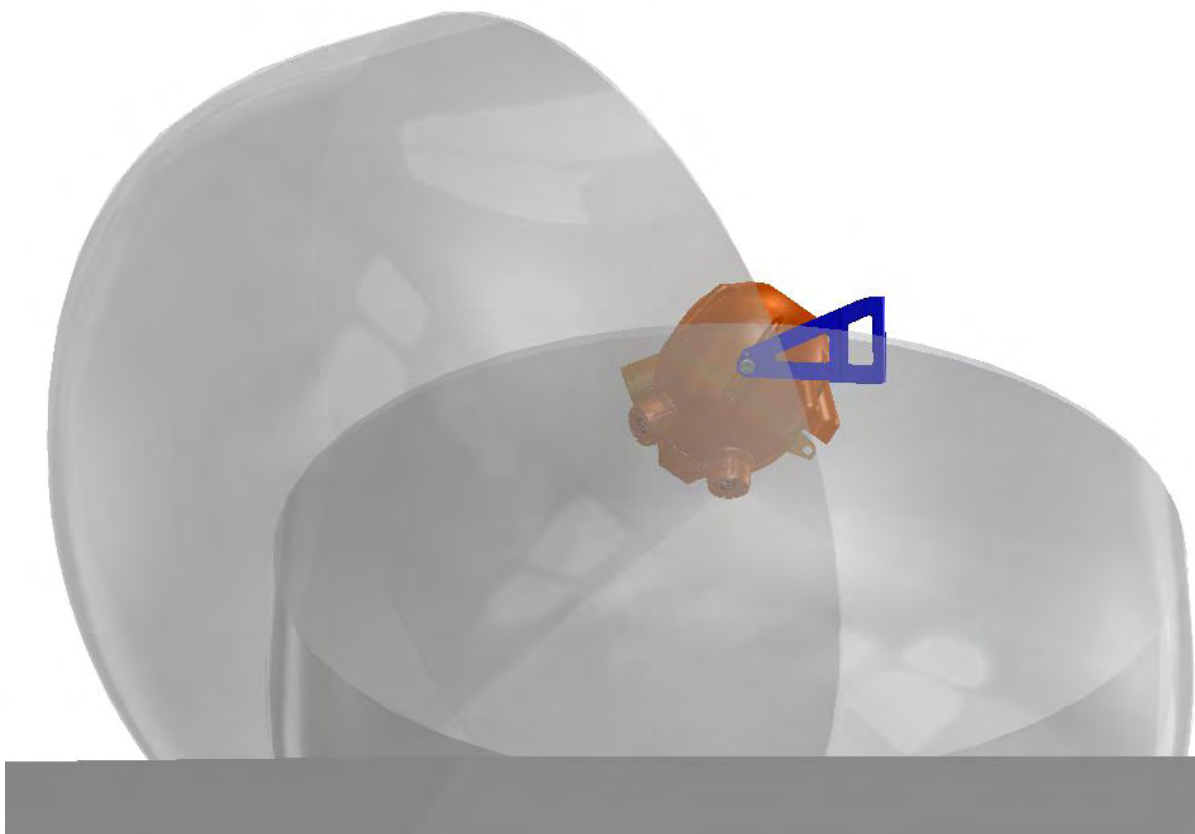
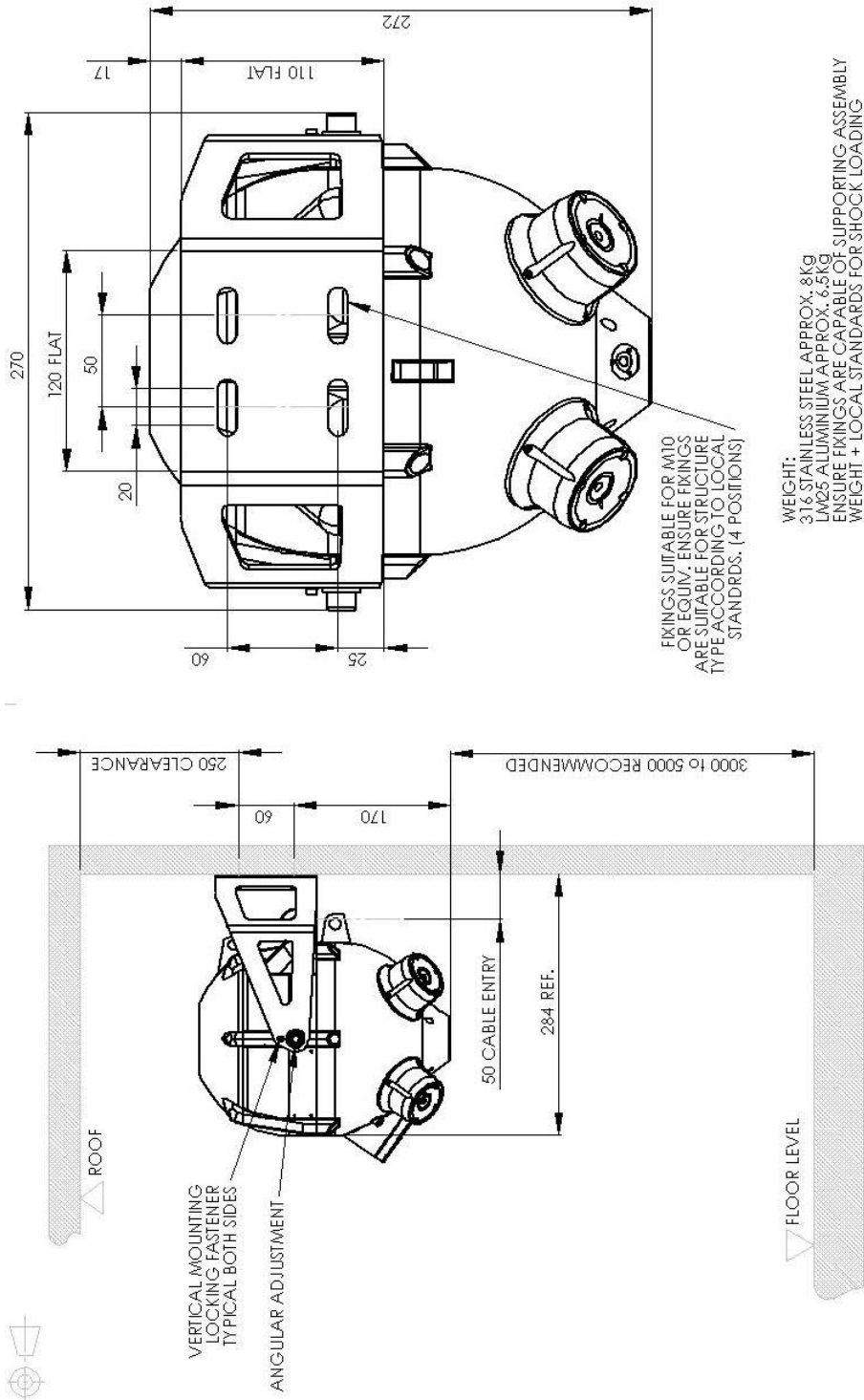

Figure 3

Figure 3 shows coverage when the detector is mounted at an angle, this method is recommended when the detector is mounted close to a wall or in an enclosed space to increase the coverage area.

3.1.3. WALL / FLAT SURFACE MOUNTING



When mounting on a vertical flat surface such as a wall with no significant vibration (<20kHz) it is sufficient to use just the standard mounting bracket supplied with the NSM-SU343.

3.1.4. POLE MOUNTING

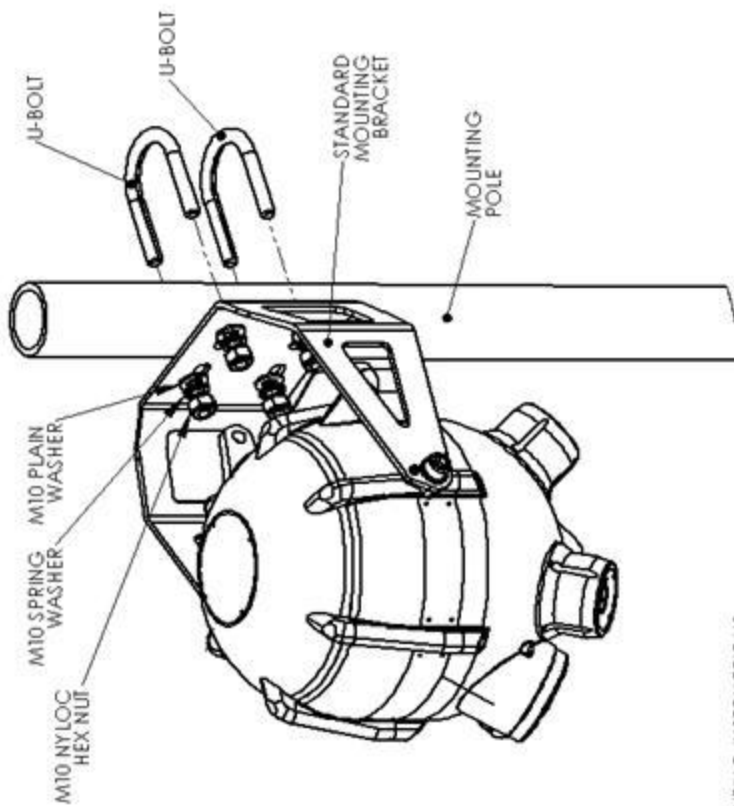

POLE MOUNTING INSTRUCTIONS
 U-BOLT SIZE SHOULD BE SPECIFIED AT TIME OF ORDER. STANDARD SIZES AVAILABLE FOR THE FOLLOWING TUBE SIZES : Ø25.4mm (1"), Ø38.1mm (1.5"), Ø50.8mm (2"). OTHERS AVAILABLE ON REQUEST.
 GDU-INCUIS CAN BE ROTATED 360 ° AROUND THE POLE WITH ANGULAR ADJUSTMENT TO ENHANCE DETECTION COVERAGE.

FREE STANDING POLE SIZE SHOULD BE SPECIFIED TO SUPPORT THE GDU-INCUIS TO LOCAL STANDARDS.
 WEIGHT OF ASSEMBLY FOR ALUMINIUM = 6.5kg APPROX.
 WEIGHT OF ASSEMBLY FOR STAINLESS STEEL = 8.0kg APPROX.
 ENSURE CALCULATIONS EMPLOY SUITABLE CIVIL FACTOR OF SAFETY TO SUPPORT EXTENDED WEIGHT AT DETECTION HEIGHT.
 ENSURE NYLOC FIXING NUTS ARE TIGHTENED TO 9Nm OR APPLICABLE LOCAL STANDARDS.
 ENSURE U-BOLTS ARE SUITABLE FOR POLE DIAMETER.
 CONTACT GROVELEY REPRESENTATIVE FOR POLE MOUNTING VARIATIONS.

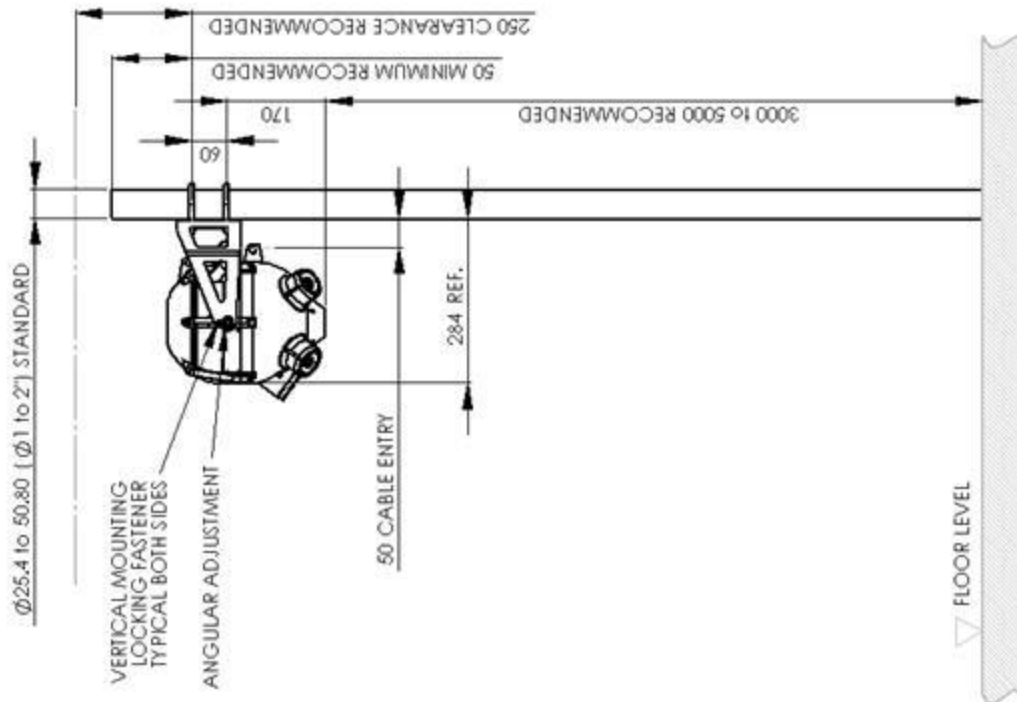

In large open areas it is recommended that the NSM-SU343 is pole mounted to take advantage of the large omni-directional detection coverage. The detector should be mounted 3 to 5 meters (10 to 16 feet) high to eliminate reflections and ground absorption. NSM-SU343 may be used lower than 3 meters (10 feet) but coverage may be reduced, please contact Net Safety Monitoring or a Net Safety Monitoring representative for details.

Pole should be mounted to local standards and be capable of supporting the detector weight at the installation height when environmental factors are taken into consideration.

NSM-SU343 is attached to the pole using 2 U-bolts fixed to the mounting bracket. Suggested U-bolt torque is 9Nm but local standards should be used in the first instance.

NSM-SU343 can be supplied with a vertical mounting accessory that allows the detector to be mounted on a ceiling / upper deck or a horizontal pipe.

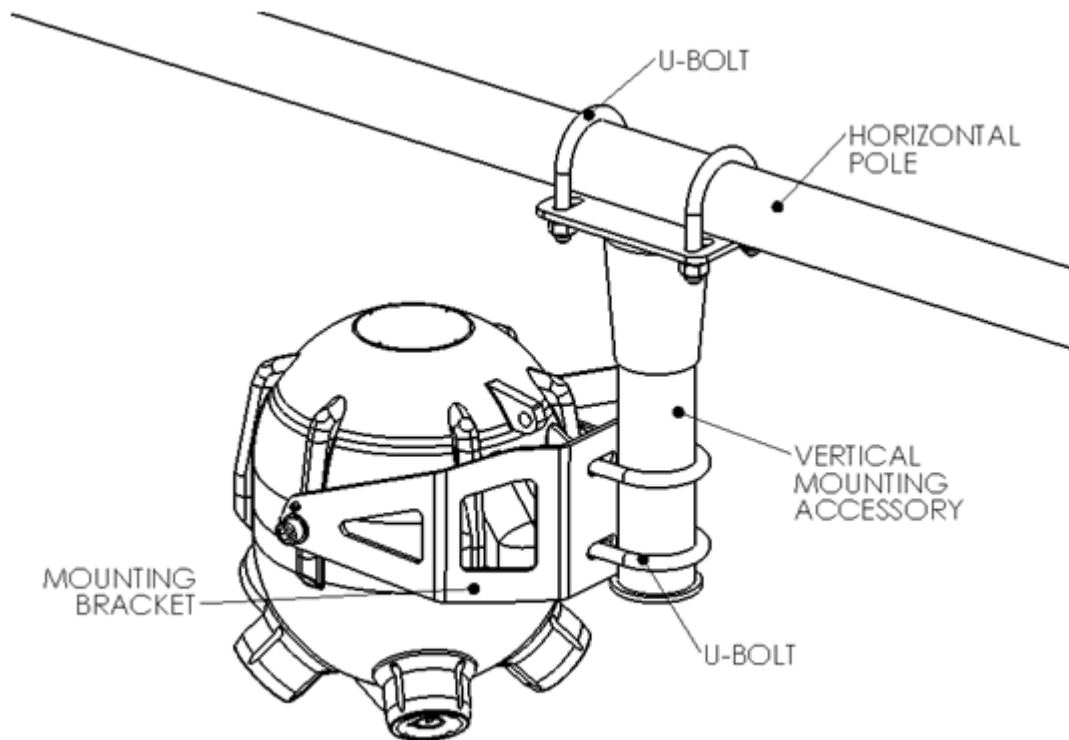

Figure 4

Figure 4 shows typical mounting arrangement for a horizontal pole. If ceiling or upper deck mounting is required the upper U-bolts can be replaced using appropriate fixings.

3.1.5. VIBRATION MOUNTING

If significant vibration (resonance) is found at the mounting point (below 20kHz) it is recommended that the vibration plate is used to eliminate excessive stress on the fixings and internal components of the detector.

If significant vibration is found at the mounting point in the detector sensing range (between 20kHz and 100kHz) the vibration plate must be used to avoid spurious results.

NSM-SU343 can be mounted on a wall / flat surface or a pole subject to vibration as described in sections 3.1.3 and 3.1.4 using the vibration damping plate accessory.

The vibration damping plate assembly can be supplied with a range of different frequency dampers to eliminate vibrations for all applications and can easily be attached to both the wall / flat surface or pole mounting as follows;

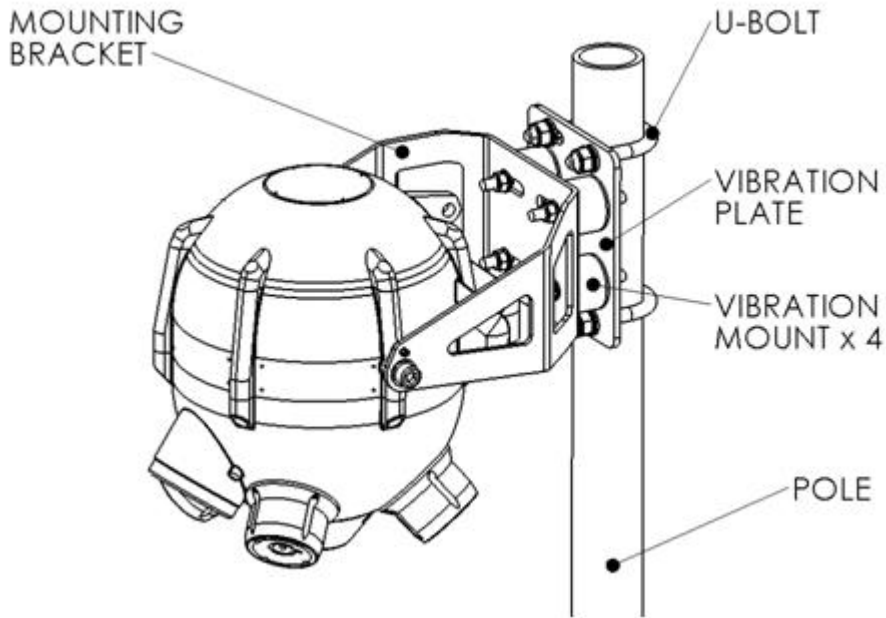

Figure 5

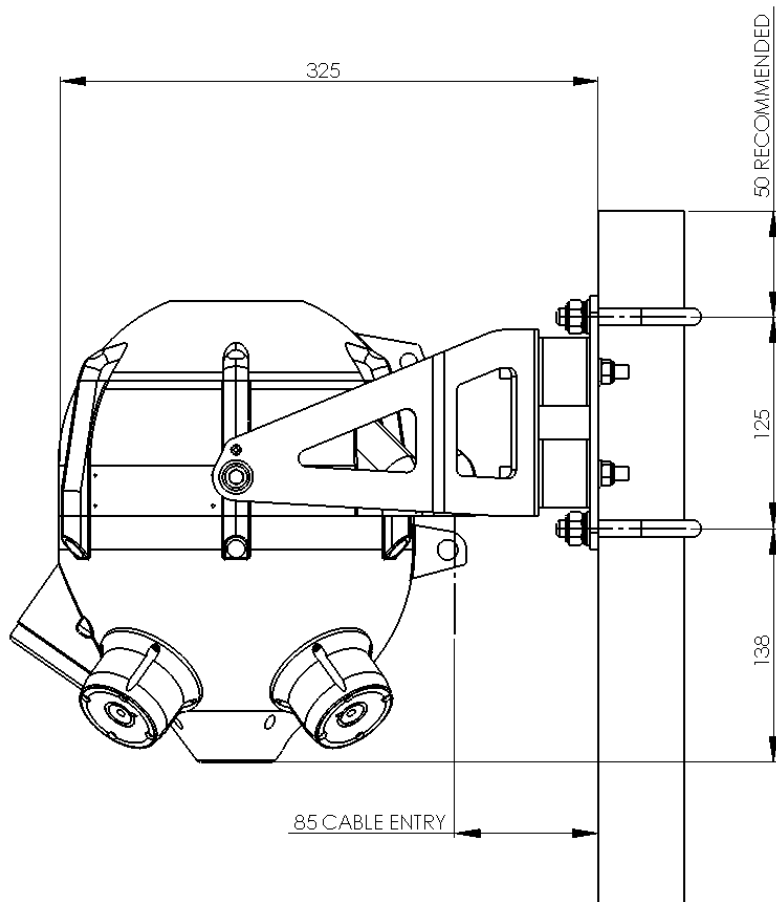

Figure 6

Figure 5 and Figure 6 show general details for mounting on a surface or pole that has severe vibration in the detector range or which may affect operation.

If vibration at fixing point is suspected please contact Net Safety Monitoring or a Net Safety Monitoring representative for details.

3.1.6. ELECTRICAL INSTALLATION



Warnings:

NSM-SU343 terminal cover is certified to flameproof standards and should not be opened whilst energized.

The detector housing should be connected to local ground via the external earth point as shown in Figure 7. Wire should be minimum of 4mm² (8 AWG) and as short as possible. Termination at detector should be suitable for M6 (0.25”) fastener. Ensure earth wire is attached using the supplied spring washer.

NSM-SU343 is temperature rated between -55°C and +85°C (-67°F and +185°F) ensure that all cable is rated to the appropriate temperature of installation. See section on external cables later in this section.

General

To gain access to the terminal compartment undo the six terminal cover fixing screws and raise the terminal cover until it reaches the pivot point then rotate towards the back of the detector. The captive mechanism has 3 locking positions to allow the terminal cover to be held open at different heights to aid cable termination. The terminal cover release pin should be pulled outwards to allow the terminal cover to be opened as required. Upon completion of wiring pull the terminal cover release pin outwards and rotate the terminal cover lid until parallel with the detector main body and lower back into position. Tighten the six terminal cover fixing screws to a torque of 9Nm.

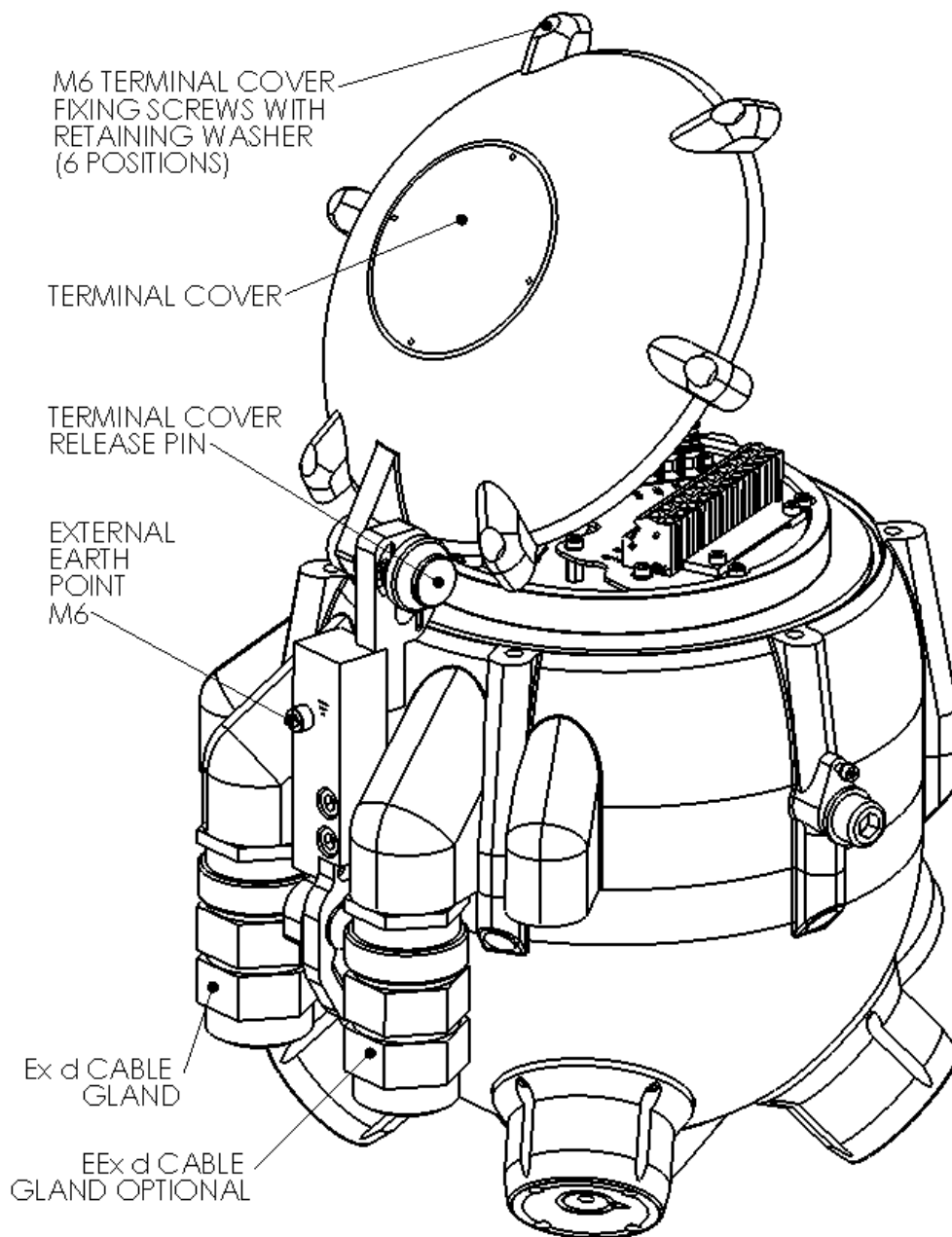

Figure 7



Cable entry is via suitable hazardous area approved and ingress protection certified cable glands (customer supply). NSM-SU343 has 2 positions (1 standard, 1 optional) for cable gland sizes M20, M25, 1/2" NPT or 3/4" NPT. Cable glands should be fitted in accordance with cable gland manufacturers instructions for assembly to a certified flameproof enclosure. All unused cable glands should be sealed using a flameproof certified plugging device. Ensure all cable gland and plugging devices are ingress protected to the same standard as the enclosure to maintain certification and are suitable for the size of cable used.

Note: Thread size for cable entry is specified for each position on the terminal cover label.

The terminal cover contains two sealed O rings to prevent water ingress into the terminal compartment. Before closing it is recommended that a visual inspection is undertaken to ensure the O rings are in place and undamaged. Also check the flame paths of the terminal cover and main enclosure for signs of damage. Send the detector to Net Safety Monitoring for repair if the flame path is damaged. See Figure 8 for O ring and flame path positions.

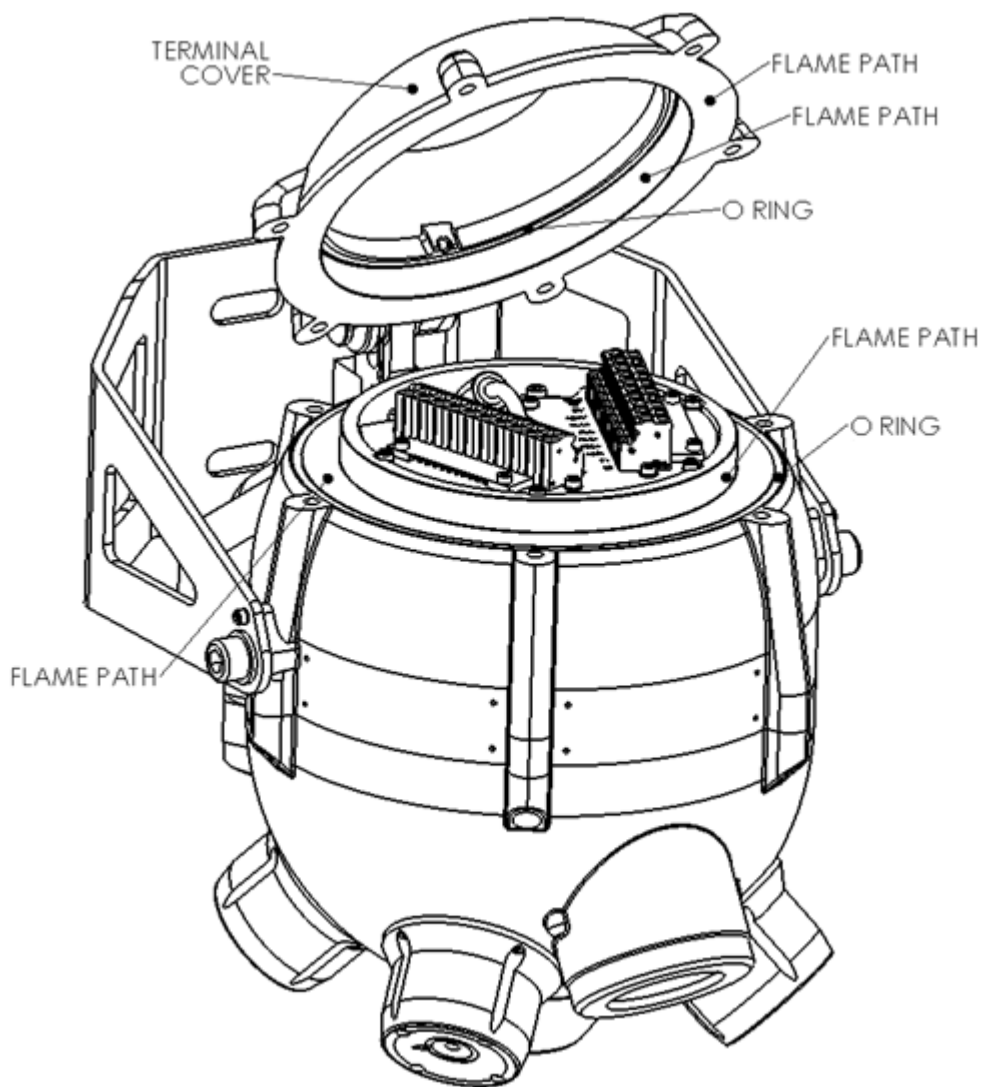

Figure 8

Cable shield should be connected to instrument earth in the control room only unless extra RFI protection is required and all local and site grounding regulations are met in which case the shield is to be terminated to local ground via one of the internal earth points shown in Figure 9.

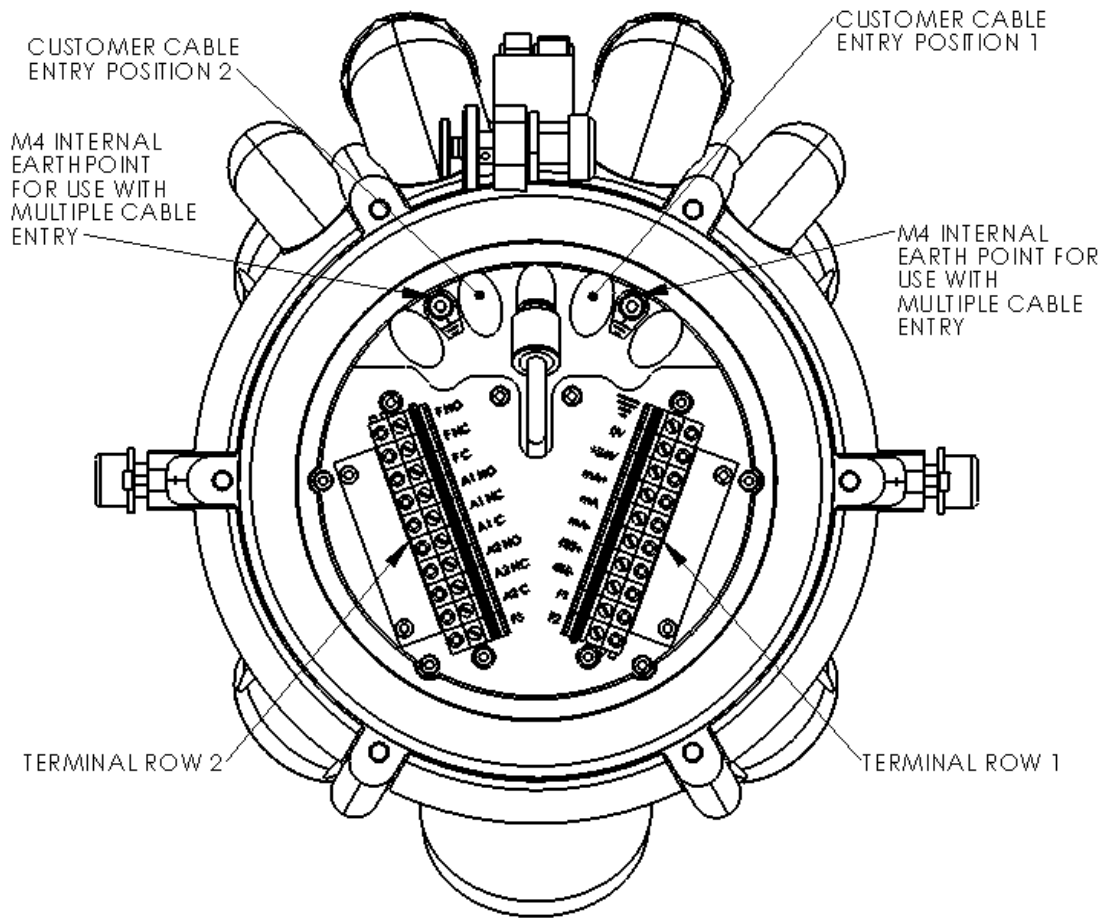

Figure 9

Figure 9 shows a view of the NSM-SU343 with the terminal cover removed. For single entry enclosures customer cable entry is via position 1 whereas dual entry enclosures will use positions 1 and 2.

The terminals are separated into power and communications for terminal row 1 and relay outputs for terminal 2.

Wiring Configurations

	TERMINAL ROW 2		TERMINAL ROW 1
F NO	FAULT RELAY NORMALLY OPEN		SINGLE CABLE ENTRY INTERNAL EARTH
F NC	FAULT RELAY NORMALLY CLOSED	0V	24V RETURN - (0V)
F C	FAULT RELAY CIRCUIT CONTACT	+24V	+24VDC (15 to 30 VDC)
A1 NO	ALARM 1 NORMALLY OPEN	mA +	FACTORY USE ONLY
A1 NC	ALARM 1 NORMALLY CLOSED	mA	4 - 20 mA OUTPUT
A1 C	ALARM 1 CIRCUIT CONTACT	mA -	FACTORY USE ONLY
A2 NO	ALARM 2 NORMALLY OPEN	485 +	RS485 + (EIA 485)
A2 NC	ALARM 2 NORMALLY CLOSED	485 -	RS485 - (EIA 485)
A2 C	ALARM 2 CIRCUIT CONTACT	F1	FACTORY USE ONLY
F3	FACTORY USE ONLY	F2	FACTORY USE ONLY

Figure 10

Figure 10 shows descriptions for cable entries for terminal rows 1 & 2.

Current source is the standard default operation, current sink is an option and should be specified at time of order.

For standard 3 wire connection inputs should be connected to Terminal Row 1 in positions +24V and 0V with 4 – 20mA output connected to the mA terminal. Maximum load resistance : 500 Ω.

Relay data : 2A, 250VDC switch voltage, 70 milliohm on-resistance.

For a full description of fault relays refer to section 3.3.6.1 Relay Options.

External cables:



Customer cable should be chosen in accordance with Hazardous Area Certification and applicable local regulations. Note: NSM-SU343 has a temperature rating of +85°C (185°F), when used in areas with an ambient temperature above 60°C (158°F) ensure cable has a rating that is equal to or exceeds the proposed maximum working temperature.

The following data indicates maximum cable length restriction due to voltage drop:

Conductor CSA	0.5mm ²	1.0mm ²	1.5mm ²	2.5mm ²
24 VDC no heater cable length	355M	695M	1095M	1805M
24 VDC with heater cable length	40M	76M	120M	200M

Note: Figures shown for the heater option are for indication only and can usually be improved depending upon environmental factors as it is extremely unlikely full heating power will be required.

Refer to section 3.3.5 Heating for description and power requirements for optional heating function or contact a Net Safety Monitoring representative for further details.

3.2. COMMISSIONING

3.2.1. VISUAL

Before powering up NSM-SU343 the following should be inspected:

- Ensure detector is correctly situated for area of detection.
- Ensure mounting bracket is secured to mounting points on the detector and mounting surface / pole.
- Check pole mount (if present) for suitability to withstand detector weight and environment.
- Ensure External earth is correctly attached using spring washer.
- Ensure correct cable gland installation and appropriate certification or local regulations have been observed.
- Ensure external cable is suitable for operating environment.
- Check correct cable installation in the terminal compartment, ensure terminal compartment flame paths and seals are intact. Tighten terminal cover bolts to 9Nm recommended torque.
- Ensure main enclosure bolts are in place and tighten to 9Nm recommended torque.
- Check display glass for damage or contaminants that may obscure display or Infra-red ports.
- Check sensors, sensor pods and cleaning nozzles for signs of damage.
- Ensure pump compartment is secure and check breather membrane for signs of damage or blockage.
- Ensure correct operating supply voltage.

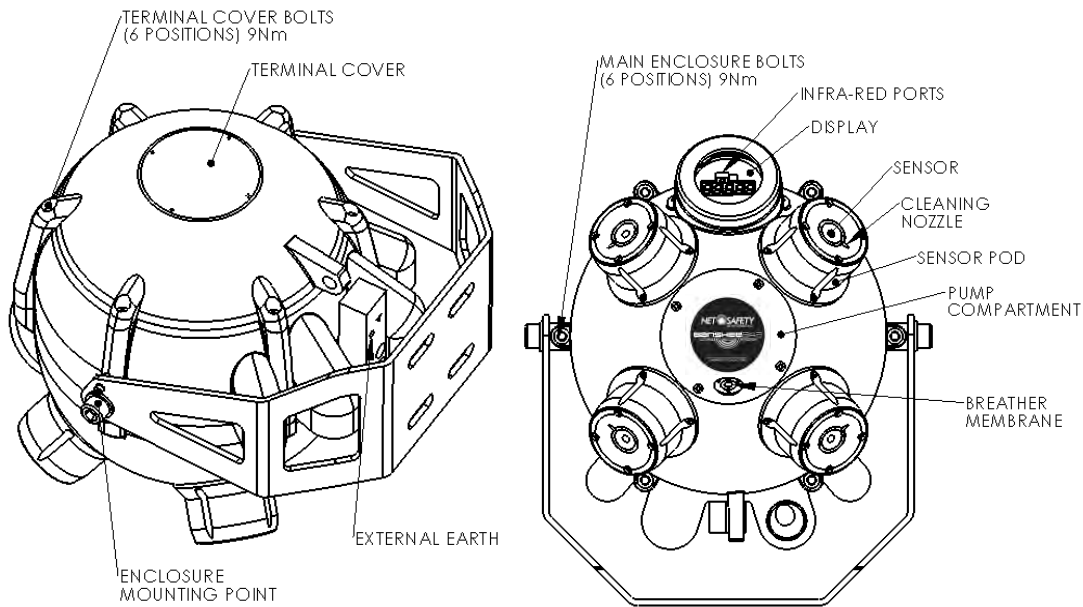

Figure 11

Ensure that all Installation procedures have been applied.

3.2.2. POWER UP

Upon power up a brief diagnostic check will run to ensure detector functionality which will last for no more than 20 seconds. Once completed NSM-SU343 will go into normal operation using the factory/customer defaults specified at time of order or signal any faults that may be present. Factory default options can be found in section 3.3.1 Normal operation and a list of faults can be found in section 3.3.6.4 Fault Outputs.

In addition, the display will show the real-time ultrasonic sound level and the detector will become responsive to RS485, Infra-red commands for function set-up and all relays will be energized or de-energized as per defaults.

Note: If NSM-SU343 has been factory set for specific site requirements it is recommended to carry out the steps outlined in section 3.2.4 Function Check before completion of Commissioning.

3.2.3. USER CHANGEABLE FUNCTIONS SET-UP

NSM-SU343 is supplied with a range of defaults designed to ensure safe working without adjustment but to enable the detector to work to maximum effect it is also possible to change a number of settings to increase the detection range and sensitivity, increase speed of response, decrease the possibility of spurious alarms and increase or decrease the internal safe-working safety checks contained within the detector.

It is recommended that certain parameters are only to be changed after detailed analysis of the installation position and site safety protocol. Therefore, the following user changeable functions are listed using a scale of 1 to 4 to signify potential risk of change, 1 representing safe change, 2 representing minor risk, 3 representing medium risk and 4 representing high risk. All functions can be disabled or password protected to fit site or local regulations.

Function	Change Level
Set Display Brightness	1
Set Pulse Filter	1
Set 'CLEAN' Display	1
Start Cleaning Cycle	1 to 2
Set Relays Normally Open	1 to 4
Set Relays Latching	2
Set Heat Enable	2
Reset Alarms	2 to 3
Set Test Interval	3
Initialise Factory Defaults	3
Set Alarm Level	3 to 4
Set Alarm Delay	3 to 4
Set Unit Address ID	4

Function Definition

- Set Display Brightness:** Changes LED intensity to suit environment or increase viewing distance. See section 3.3.6.2 Display Options for full definition.
- Setting values; 0 to 32 with 0 representing off and 32 representing maximum. Factory default value = 12.
- Potential change risk = safe. Changing the display brightness will have no impact on safe working of the detector. It is recommended that the display is not changed to a value less than 7 as light emitted is extremely low and, therefore, difficult to see in most environments. Also setting the display at maximum may shorten the life of the LED.
- Set Pulse Filter:** Changes display response time to cancel out spikes of ultrasonic noise. See section 3.3.6.2 Display Options for full definition.
- Setting values; 0 to 127 seconds. Factory default value = 0 seconds (instantaneous). Note: It is recommended to keep pulse filter duration less than alarm delay duration.
- Potential change risk = safe. Changing pulse filter duration will have no impact on safe working of the detector.
- Set 'tEst' Display:** Changes display information during test cycle. See section 3.3.6.2 Display Options for full definition.
- Setting values; 0 or 1 with 0 representing the word 'tEst' and 1 showing numerical code for test sequence pass, see section 3.3.6.2 Display options for full details. Factory default value = 0.
- Potential change risk = safe. Changing 'tEst' display will have no impact on safe working of the detector.
- Start Cleaning Cycle:** Initiates a forced cleaning cycle. See section 3.3.4 Self Test and Self

Clean for full definition.

Potential change risk = safe to minor. Used intermittently in conjunction with the built-in cleaning cycle interval the forced cleaning cycle is safe to use. The change risk increases if the forced cleaning cycle is used regularly as it temporarily reduces detection coverage and increases detector reaction time if it coincides with the start of a leak.

Set Relays Normally Open: Allows relay configuration to be switched between energised in normal operating condition or energised when in fault condition. Factory default = energised in normal operating condition.

Potential change risk = safe if changed to energised in normal operating condition, high risk if changed to energised when in fault condition if power supply is not independently monitored. Changing relay operating state will cause a local alarm under normal conditions, other communication with control room will be unaffected.

Set Relays Latching: Allows relays to be latching or non-latching. Factory default = non-latching.

Potential change risk = minor. Local alarms will turn off when detector comes out of alarm if left unlatched or stay in alarm after the detector comes out of alarm, other forms of communication with control room will be unaffected.

Set Heat Enable: Allows optional heating function to be turned permanently on or off or automatic to adjust to the environment. See section 3.3.5 Heating for full definition. Setting values 0 to 2 with 0 representing off, 1 representing automatic and 2 representing on. Factory default = 1.

Potential change risk = minor. NSM-SU343 will work with or without heating enabled but it is recommended to leave the heat setting in automatic to ensure the cleaning function is unaffected by ice build-up at low temperatures.

Reset Alarms: Allows latching relays to be reset.

Potential change risk = minor to medium. Operation of NSM-SU343 is unaffected but it is recommended that only qualified personnel as dictated by site protocol are allowed to reset alarms.

Set Test Interval: The test cycle interval defines the duration between detector self-check. Test cycle consists of two functions on each sensor, a broadband self-test and cleaning of the sensor face to remove contaminant. See section 3.3.4 Self Test and Self Clean for full definition.

Setting values; 0 to 127 in increments of 1 minute with 0 representing off, 1 representing 1 minute and 127 representing 127 minutes. Factory

default setting 15 minutes.

In areas of low background noise it is recommended that the cleaning interval is set to 15 minutes but may be changed to suit existing site protocol.

Potential change risk = medium. Operation of the NSM-SU343 is unaffected but it is recommended that the test cycle interval is set as per site protocol and only qualified personnel as dictated by site protocol are allowed to change duration time.

Initialise to Factory Defaults:

Changes all function settings back to default values. See section 3.3.1 Normal Operation for full definition.

Potential change risk = medium. NSM-SU343 factory default settings are defined to provide safe working conditions but once NSM-SU343 is set-up to provide optimum detection coverage it is recommended that only qualified personnel as dictated by site protocol are allowed to restore Factory Defaults.

Set Alarm Level:

Changes dB level of detector alarm. See section 3.3.2 Alarm Level for full definition.

Setting values; 40 to 127 in increments of 1dB with 40 representing 40dB and 127 representing 127dB. Alarm level default = 70 (70dB).

Potential change risk = medium to high risk. If alarm level is raised too high above the background level it will reduce detector sensitivity. It is recommended that only qualified personnel as dictated by site protocol in conjunction with Net Safety Monitoring personnel are allowed to change alarm levels.

Note: Alarm level can also be set at control room or panel.

Set Alarm Delay:

Changes duration of time that constant alarm dB level must be experienced before alarm is activated. See section 3.3.3 Alarm Delay for full definition.

Setting values; 0 to 99 in 10 second increments and 100 to 127 in 1 second increments. 0 and 100 represent 'off' instantaneous alarm, 1 represents 10 seconds and 99 represents 990 seconds. 101 represents 1 second and 127 represents 27 seconds.

Factory default = 3 (30 seconds).

Potential change risk = medium to high. If delay is too short spurious alarms may occur, if delay is too long, dangerous gas build up may occur. It is recommended that only qualified personnel as dictated by site protocol in conjunction with Net Safety Monitoring personnel are

allowed to change alarm delay times.

Note: Alarm delay level can also be set at control room or panel.

Set Unit Address ID: Changes RS485 unique identity.

Setting values; 1 to 31 (126 option). Factory default = 1.

Potential change risk = high. If two units are given the same RS485 ID then it is impossible to relay information to individual detectors on the same control loop.

It is recommended that set-up of ID address is undertaken by qualified personnel as dictated by site protocol in conjunction with Net Safety Monitoring personnel and upon completion changes are tightly controlled.

3.2.4. FUNCTION CHECK

NSM-SU343 sensors are factory calibrated and require no adjustment before operation but functionality checks are recommended to ensure correct installation.

On power up the NSM-SU343 will perform a diagnostic check to ensure all main functions are operational but the following additional checks may be undertaken:

Sensor Functionality

Sensor functionality can be checked in a number of ways;

Internal forced test cycle – faulty sensor(s) will be shown as a fault on the display and via 4 – 20 mA signal output. See section 3.3.6.4 Fault Outputs.

NSM-SU343 hand held series test transmitter sound source. Ensure that the background ultrasonic level is suitable for the distance of proposed test transmitter test. Aim the transmitter at the sensor face at a known distance, NSM-SU343 display dB level will rise according to hand held device used and distance. Check all 4 sensors if possible by moving round the detector and repeating.

Test Verification kit – a pressurized gas release of a known pressure and size at a known distance. NSM-SU343 display level will rise according to the size, pressure and distance used.

- Check all other user required variables as described in section 3.2.3 User Changeable Functions Set-up.

3.3. OPERATING PRINCIPLES / INSTRUCTION

3.3.1. NORMAL OPERATION

On power up the NSM-SU343 initializes a diagnostic check and then enters normal operation mode as per factory defaults supplied.

Factory default 1 settings;

- 4 – 20mA set to linear dB output.
- Display brightness set to 12. Viewing distance +10M outdoor environment.
- Real time instantaneous ultrasonic sound level shown on display in dB.

- Display shows 'tEst' when in Self-Test and Self-Clean mode.
- Forced Clean enabled.
- Relays are energized open, loss of power causes alarm (fail-safe).
- Relays are set to non-latching.
- Heating set to automatic, system activates below 5°C (41°F).
- Reset alarms enabled, allows latched relays to be reset and restarts alarm delay.
- Self-Test and Self-Clean set to activate at 15 minute intervals.
- Alarm level set at 70dB.
- Alarm delay set to 30 seconds.
- RS485 ID set to 1.

In addition all communication ports are active and ready to receive commands.

Factory default 2 settings;

- 4 – 20mA set to 4mA when in fully functioning non-alarm condition.
- Display brightness set to 12. Viewing distance +10M outdoor environment.
- Display shows 'CLEAN' when in Self-Test and Self-Clean mode.
- Forced Clean enabled.
- Relays are energized open, loss of power causes alarm (fail-safe).
- Relays are set to non-latching
- Heating set to automatic, system activates below 5°C (41°F).
- Reset alarms enabled, allows latched relays to be reset and restarts alarm delay.
- Self-Test and Self-Clean set to activate at 15 minute intervals.
- Alarm level set at 70dB
- Alarm delay set to 30 seconds
- RS485 ID set to 1

In addition all communication ports are active and ready to receive commands.

Further default settings are available on request.

3.3.2. ALARM LEVEL

To avoid false alarms it is recommended to set the alarm level above the background level found through mapping when all process is operational. If the background level is unknown it is recommended to analyze the background using the detector. Care should be taken to observe process that may cause intermittent ultrasonic noise such as pressure relief valves.

Please contact Net Safety Monitoring or a representative for advice on alarm levels.

Note: the higher the alarm level the smaller the detector coverage radius, it is therefore important to establish a safe alarm level at the lowest permissible value.

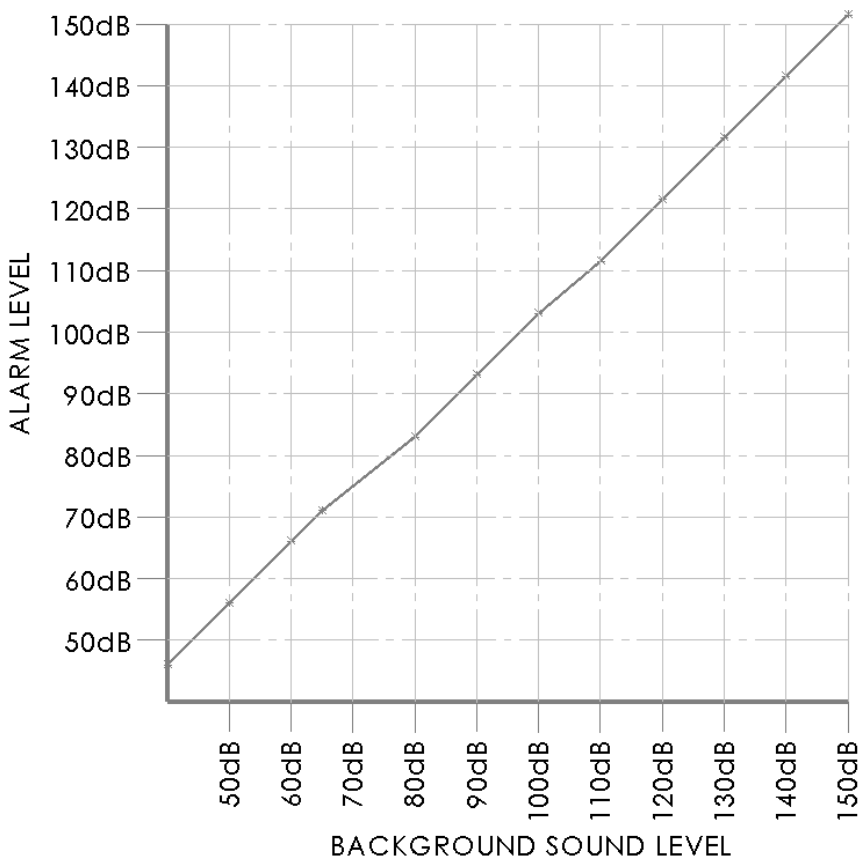

Figure 12

Figure 12 shows suggested alarm level settings for known background sound level. The values shown have been found to provide sufficient immunity against most spurious alarms but care should be taken to survey the area of installation for potential spurious noise such as pressure relief valves, audible alarms with resonance or maintenance hotspots.

If background levels are unknown typical historical process background levels can be used along with a safety factor. Please contact Net Safety Monitoring or a representative for historical values and guidance.

Alarm levels can be set at the detector or at the control panel if functionality is available.

Factory Default standard alarm level is 70dB. See section 3.2.3 user changeable functions.

3.3.3. ALARM DELAY

To avoid spurious alarms it is recommended that an alarm delay is used for non-toxic applications or when instantaneous detection is not required. The alarm delay is intended to activate once the ultrasonic noise alarm level threshold is reached. The alarm delay will then monitor the sound level to ensure that it does not drop below the alarm level threshold for the duration of the delay. If the ultrasonic noise drops below the alarm level threshold the delay time will be reset as shown in Figure 14. If the ultrasonic noise level remains above the alarm level threshold for the duration of the delay the alarm will be activated as shown in Figure 13.

Spurious ultrasonic noise is usually found in short time-cycles such a pressure relief valves and man-made maintenance operations such as hammering or use of pneumatic hand tools and therefore are eliminated by the delay.

Alarm delay time should be assessed with regards to the following;

- Detector proximity to release valves and intermittent ultrasonic noise sources
- Process leak severity, toxic / non-toxic, acceptable leak size before alarm
- Existing site protocols and local regulations

Note: If a gas leak occurs during spurious noise the delay time will continue from the first instance of noise above the alarm threshold level.

Factory Default standard alarm delay is 30 seconds. See section 3.2.3 User Changeable functions.

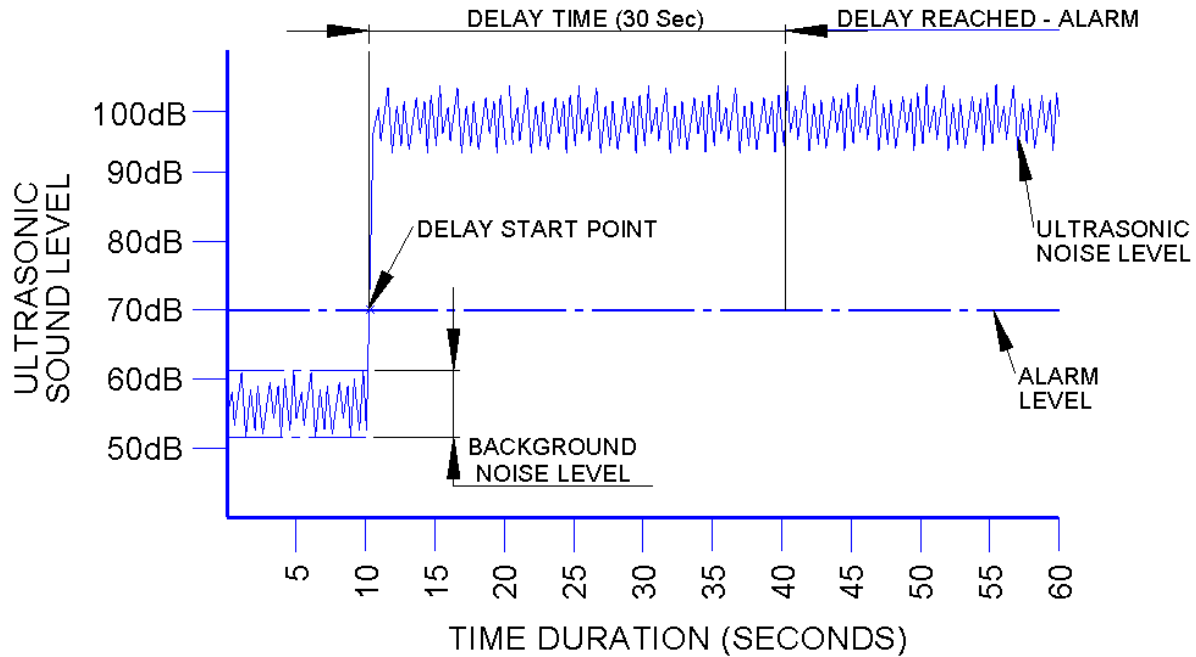

Figure 13

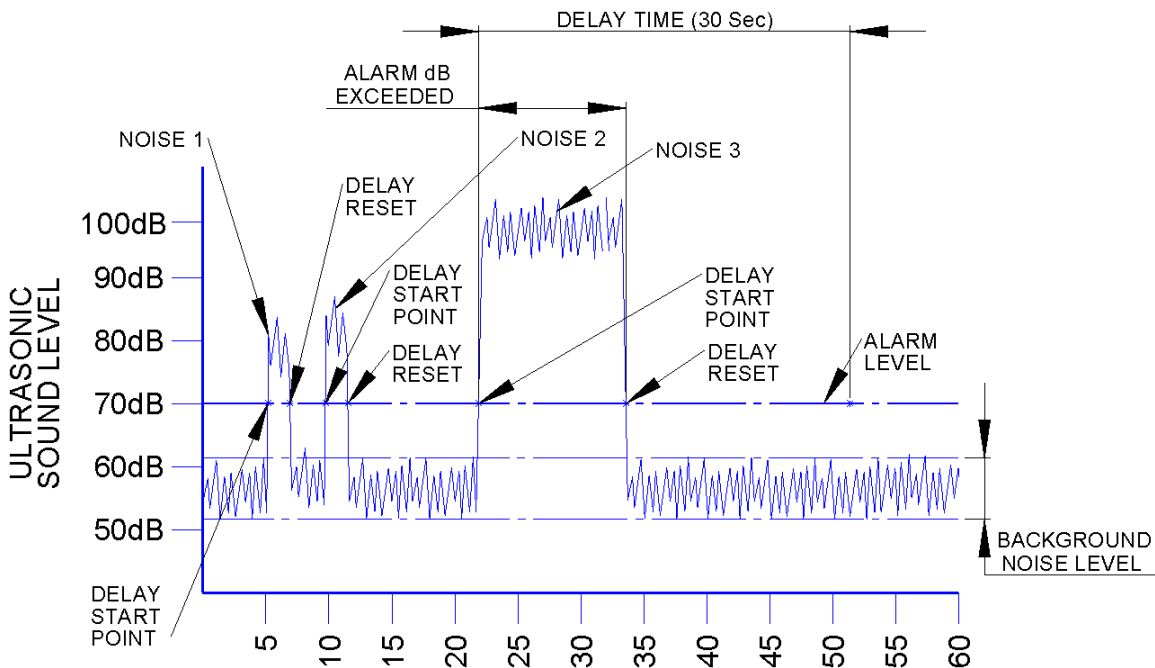

Figure 14

In Figure 14 noise 1 and 2 are spurious noise spikes of approx. 1.5 seconds, typical of man-made ultrasonic noise produced through normal maintenance procedures. Noise 3 is a longer spurious noise of approx. 13 seconds typical of a pressure relief valve. Delay time is introduced to ignore spurious noise spikes as the detector will reset when noise level drops below the alarm level before the delay time is reached.

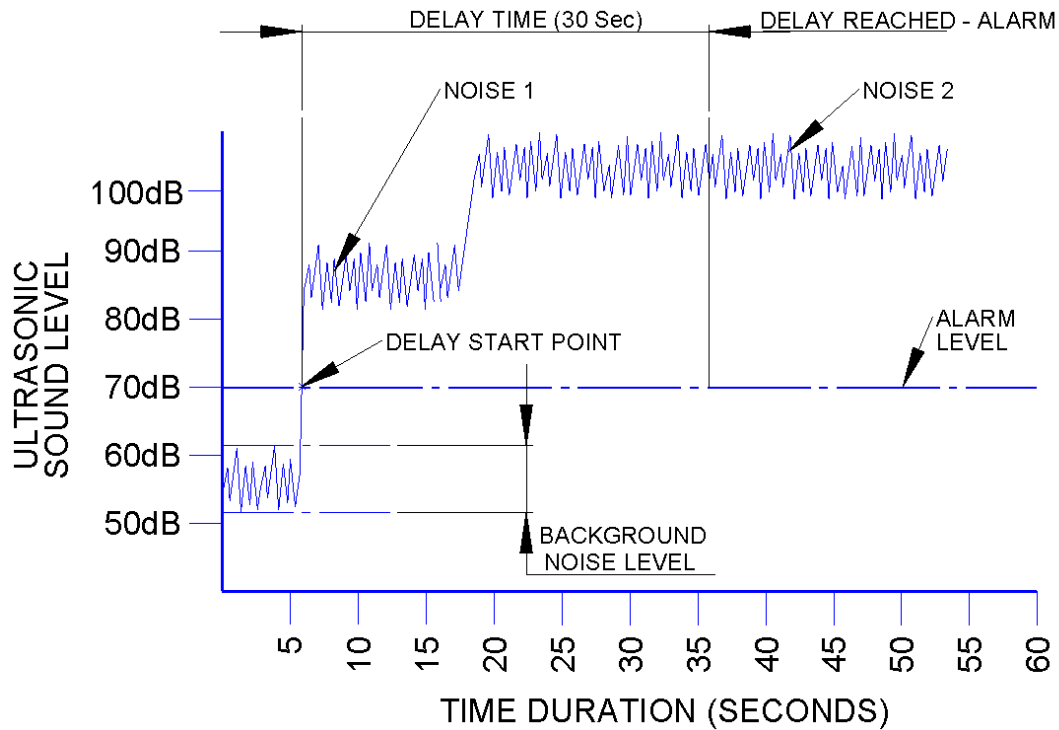

Figure 15

Figure 15 shows detector response when a leak is encountered during a spurious noise spike such as a pressure relief valve. Noise 1 represents a pressure relief valve actuating for approx. 13 seconds before a leak (noise 2) occurs. The detector starts the delay time when the pressure relief valve opens and continues to monitor for leaks. If a leak occurs during a spurious noise spike the delay time will be reduced by the duration of the spurious noise spike.

Note: It is important that all spurious noise spikes of significant duration within the detector coverage are identified. It is recommended that the alarm delay is set to a value greater than the maximum spurious noise spike operating duration. If two or more spurious noise spikes are situated in the detector coverage it is recommended to establish if operation will overlap and that the delay time is adjusted accordingly.

3.3.4. SELF-TEST AND SELF-CLEAN

Self-Test

To ensure correct detector operation NSM-SU343 incorporates an internal self-test function which uses a compressed air jet to simulate an actual gas release. The jet is forced through a nozzle designed to produce a sound pressure level in excess of 100dB across the entire detector sensing range (broadband) allowing system check to be carried out in environments with a background as high as 95dB.

The self-test is delivered to all four sensing heads independently using a self contained direct drive pump to an internal sensor chamber which is protected from the environment to allow accurate

repeatable testing without emitting any noise externally. This allows other ultrasonic detectors to be situated close by without causing spurious alarms.

Self-Clean

To allow NSM-SU343 to operate in extremely harsh environments a Self-Clean function has been incorporated. Under most conditions Ultrasonic detectors will continue to work without loss of coverage providing that debris has not built up on the sensing heads and produced air pockets which force the sound pressure level to travel through a decreasing then increasing medium density (refer to section 3.3.5. Heating for removal of ice). NSM-SU343 can be mounted in any orientation, when mounted horizontally or vertically downwards build up of debris is virtually eliminated. If NSM-SU343 is mounted vertically upwards or upwards of 45° to the horizontal, debris may build up. To ensure this does not occur the Self-Clean operates in conjunction with the self test function to remove all debris from the sensor detecting face. The Self-Test uses a compressed air jet directed at the sensing face which removes debris before build up can occur. The Self-Clean uses a nozzle designed to produce nominal amounts of ultrasonic noise so that detector functionality is not affected during use.

Test Cycle

In standard Factory Default operating mode the test cycle (combined Self-Test and Self-Clean) will activate every 15 minutes (or when one of the continuous self-testing electronic checks signals an abnormal operating parameter) and lasts for approximately 6 seconds.

Testing consists of a background noise check and self-clean to clear debris followed by an internal ultrasonic compressed air jet test to check sensor functionality for each sensor position (1 through 4 standard). Each sensor head is checked in turn to enable the detector to continue to monitor the coverage zone for leaks that may occur during testing.

The detector will analyze the sound produced by the air jet test to establish if the sensors fall within a factory determined tolerance. If the results fall outside of acceptable parameters the test will activate again and produce a test fault if correct functionality cannot be determined. If the background level exceeds 97dB before the test initiates the detector will produce a test inconclusive fault.

For a full list of fault outputs refer to sections 3.3.6.3 4-20mA Output, 3.3.6.4 Fault Outputs.

Factory Default standard self-clean is 15 minutes. See section 3.2.3 User Changeable functions.

3.3.5. HEATING (OPTIONAL)

NSM-SU343 is available with an optional environmentally controlled heating circuit to ensure functionality at temperatures as low as -55°C (-67°F) and eliminate any ice buildup over the sensor covers.

If NSM-SU343 is mounted facing upwards of 45° to the horizontal water may build up on the sensor face. Although this has no influence on the sensor performance and will normally be removed during self-clean it may cause problems if the environment is sufficiently cold to allow ice to form between self-clean cycles. Air pockets may form in the ice and this may cause a small loss of sensitivity due to the change in densities. When the heating circuit is enabled it will activate when the sensor head is just above freezing and stop ice buildup, it can then be removed by the self-clean function. In most conditions the loss of sensitivity has been built into the detector coverage, enabling the heating circuit allows for greater consistent coverage in all temperatures and environments irrespective of mounting orientation.

The heating circuit is extremely efficient as heat is only transferred to areas that require it when the temperature drops below a certain value. The external temperature is constantly monitored and the heating circuit can be set to turn on at any temperature, 5°C (41°F) as standard Factory Default.

The heating option is recommended in areas that are prone to extreme low temperatures.

Relay configuration can be changed to suit installation requirements using the user changeable functions, options include Normally Open / Normally Closed condition and latching / non-latching. See section 3.2.3 User changeable functions set up.

3.3.6.2. DISPLAY OPTIONS

NSM-SU343 incorporates a 5 digit, 7 segment, 8mm high x 4mm wide character LED display with red numerals as standard.

In standard Factory Default option the real-time dB level is continuously shown whilst below alarm level and flashing when above alarm level. Alternative options are available that include real-time mA value and display delay. When in stepped mA output mode the display will continue to display the real time dB.

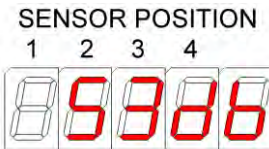

Example of real-time dB level display '53db'

During the Self-Test cycle the display will show 'tEst' for the duration of the test cycle as factory default.

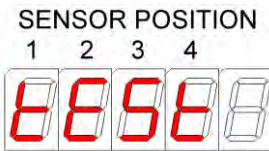

Example of Self-Test display

Test option is to display test status in numerical form for the duration of the test with 0 meaning test fail, 1 test pass and 2 test and clean pass with numeral position indicating sensor head number.

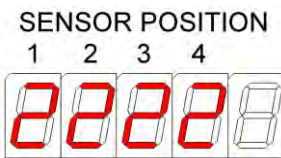

Indicates test and clean pass in all 4 sensors

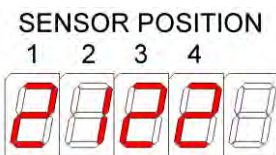

Indicates test and clean pass for sensors 1, 3 and 4, test pass and clean fail for sensor 2

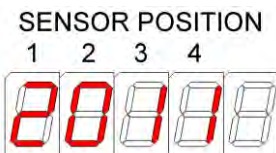

Indicates test and clean pass for sensor 1, test and clean fail for sensor 2, test pass and clean fail for sensors 3 and 4

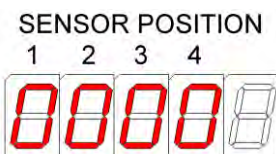

Indicates test and clean fail For all sensors

If a maintenance/minor fault occurs the display will continue to display the real-time dB value.

If a major test fault occurs the display will continue to display the real-time dB value when test is completed.

If a major fault occurs the display will shut down.

Real-time mA value mimics the mA output value sent to the control room.

Display delay can be set to delay the results shown on the LED to eliminate any spiked spurious noise events and display a more consistent value.

Stepped mA output enables connection to systems requiring inputs which mimic other forms of gas detection such as point IR detectors. Standard Factory Default option is set to continuous real-time dB when below alarm level and flashed real-time dB when in alarm.

Display settings can be changed using the user changeable functions, options include brightness, delay and self test text setting. See section 3.2.3 User Changeable functions Set-up.

3.3.6.3. 4-20MA OUTPUT

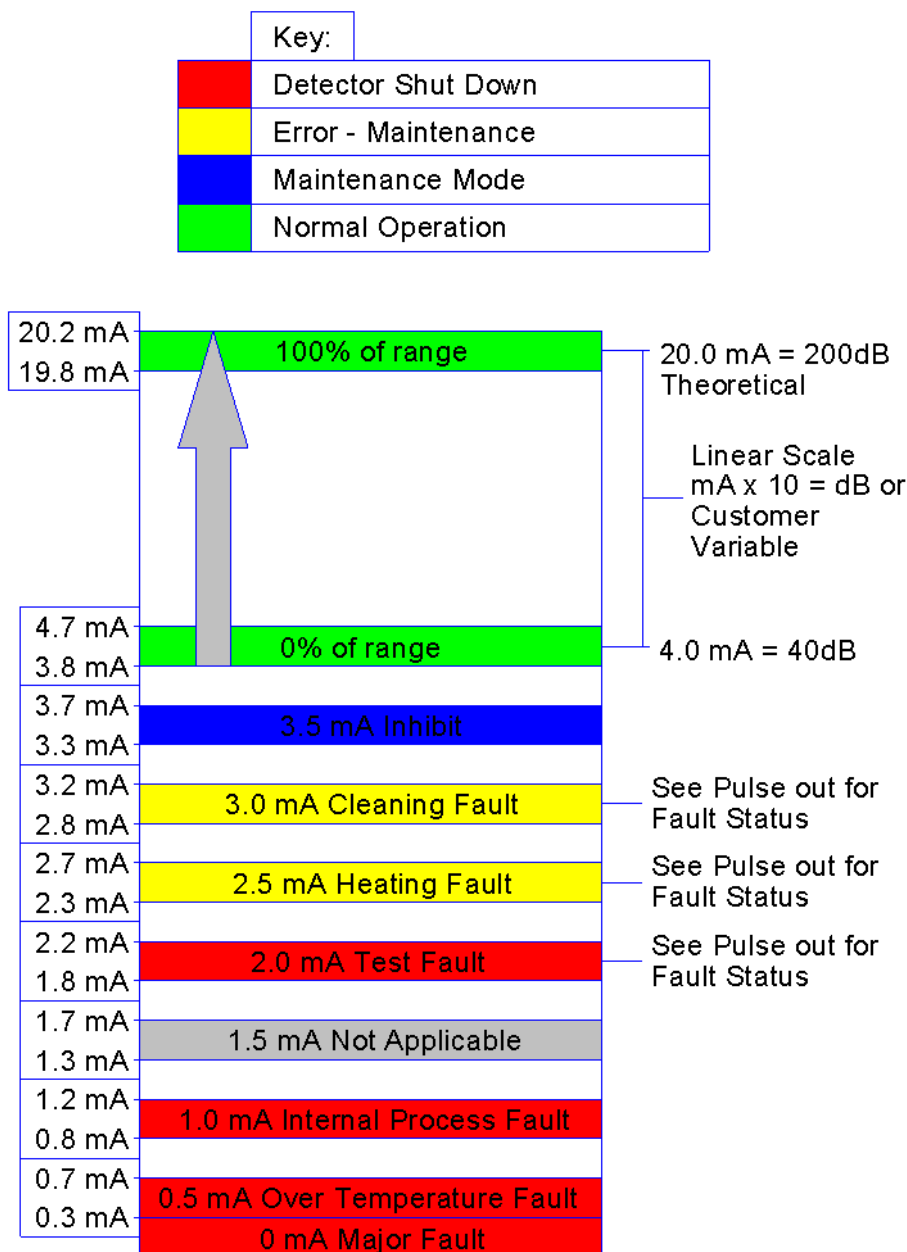

Figure 16

Figure 16 shows the 4 – 20mA output values for all detector variants and various fault conditions depending on detector set up. Value on the left side shows the mA output tolerance band, Test fault is set for a 2.0mA output with a tolerance of 1.8 to 2.2mA for example.

Normal operation is shown with an upper tolerance of 4.7mA (+/-0.3mA) as the gain is usually set to a minimum working level of 47dB.

mA outputs are grouped in descending order to signify importance and to allow for instant status recognition, see section 3.3.6.4 Fault Outputs for options;

Normal operation between 4 to 20mA (+/- 0.2mA) – detector working, no fault conditions.

Inhibit 3.5mA (+/- 0.2mA) – Maintenance mode, detector is in self-test mode (option) or receiving communication via RS485 or infra-red.

Error – Maintenance between 2.5 to 3mA (+/- 0.2mA) – detector still functioning safely but requires maintenance in area described by mA output. Maintenance errors are signaled using an optional pulsed interrupt output via the 4-20mA signal during the normal operation signal.

Detector shut down 0 to 2mA (+ 0.2mA) – detector has stopped functioning due to serious known fault ,0.5 to 2mA, or serious unknown fault ,0mA. Note: Optional 2.0mA pulsed signal output falls into Error – Maintenance classification.

Serious known faults include test fault, microprocessor watchdog fault, circuit test fault or high voltage fault up to 40VDC

Serious unknown faults include microprocessor fault, low voltage input, high voltage input above 40VDC or loss of power.

3.3.6.4. FAULT OUTPUTS

Option 1 Standard

2.0mA Test Fault

Test fault when three or more sensor heads fail to respond to test leak (when background is below 95dB). Output is continuous until reset or test is passed successfully.

All alarm conditions (gas leak) or major faults will override this fault condition.

1.0mA Internal Process Fault

Continuous 1.0mA (+/-0.2mA) output for any known internal or external faults which include microprocessor watchdog fault, circuit test fault, high/low external voltage, blown fuse or high/low internal voltage. The output can be reset via control room.

0.5mA Over Temperature Fault

If the detector is subject to an ambient temperature of 87°C (188°F) or above the output is a continuous 0.5mA (+/-0.2mA) and can only be reset by Net Safety Monitoring or a Net Safety Monitoring representative due to certification restrictions.

0mA Major Fault

Output is the result of a loss of power to the detector or a serious microprocessor fault. If fault occurs due to loss of power fault will be reset when power is supplied to the detector. If fault occurs due to the microprocessor the NSM-SU343 should be returned to Net Safety Monitoring or a Net Safety Monitoring representative for repair.

Option 2 (Specify at time of order)

3.0mA Cleaning Fault

Pulsed output of 3.0mA (+/-0.2mA) for 5 seconds every minute if cleaning function is unsuccessful for 5 times in a row. Pulse output is reset if clean function is performed successfully.

All alarm conditions (gas leak) or major faults will override this fault condition.

2.5mA Heating Fault

Pulsed output of 2.5mA (+/-0.2mA) for 2 seconds every minute if either one of the internal temperature sensors is in fault.

Pulsed output of 2.5mA (+/-0.2mA) for 5 seconds every minute if heating circuit is in fault.

All alarm conditions (gas leak) or major faults will override this fault condition.

2.0mA Test Fault

Test fault when three or more sensor heads fail to respond to test leak (when background is below 95dB). Output is continuous until reset or test is passed successfully.

All alarm conditions (gas leak) or major faults will override this fault condition.

Pulsed output of 2.0mA (+/-0.2mA) for 10 seconds every minute if the test is inconclusive due to high background noise (+95dB). Output is reset if the test is completed satisfactorily.

All alarm conditions (gas leak) or major faults will override this fault condition.

Pulsed output of 2.0mA (+/-0.2mA) for 8 seconds every minute if test cannot be performed due to pump motor overload. Output is reset if the test is completed satisfactorily.

All alarm conditions (gas leak) or major faults will override this fault condition.

Individual sensor head faults;

Sensor head 1 fault – pulse 2.0mA (+/-0.2mA) for 1 second every minute.

Sensor head 2 fault – pulse 2.0mA (+/-0.2mA) for 2 seconds every minute.

Sensor head 3 fault – pulse 2.0mA (+/-0.2mA) for 3 seconds every minute.

Sensor head 4 fault – pulse 2.0mA (+/-0.2mA) for 4 seconds every minute.

Any two heads fault – pulse 2.0mA (+/-0.2mA) for 5 seconds every minute.

Output is reset if the test is completed satisfactorily.

All alarm conditions (gas leak) or major faults will override these fault conditions.

1.0mA Internal Process Fault

Continuous 1.0mA (+/-0.2mA) output for any known internal or external faults which include microprocessor watchdog fault, circuit test fault, high/low external voltage, blown fuse or high/low internal voltage. The output can be reset via control room.

0.5mA Over Temperature Fault

If the detector is subject to an ambient temperature of 87°C (188°F) the output is a continuous 0.5mA (+/-0.2mA) and can only be reset by Net Safety Monitoring or a Net Safety Monitoring representative.

0mA Major Fault

Output is the result of a loss of power to the detector or a serious microprocessor fault. If fault occurs due to loss of power fault will be reset when power is supplied to the detector. If fault occurs due to the microprocessor the NSM-SU343 should be returned to Net Safety Monitoring or a Net Safety Monitoring representative for repair.

3.3.6.5. RS485 DIGITAL

NSM-SU343 incorporates an RS485 digital interface as standard which allows the operator to change and receive status and setting information. A maximum of 32 NSM-SU343 can be connected into the RS485 interface and the communication line should be terminated between the controller and the last detector with a 150 ohm resistor. Note: NSM-SU343 main PCB can be set up as the last in line communicator if specified at the time of order. Contact Net Safety Monitoring or a Net Safety Monitoring representative for further details.

NSM-SU343 is supplied as standard with an address ID of 1 and cannot initiate communication, therefore care should be taken to assign detector address ID upon installation.

The controller should broadcast an address, a command, a variable and a checksum which will initiate a response, a variable and a checksum from the detector with the appropriate address. If data corruption occurs the checksum will initiate a repeat send of information and the initial information is disregarded.

RS485 interface uses a Baud rate of 2400 (9600 option) and should be made via shielded 'twisted pair' cable to reduce interference.

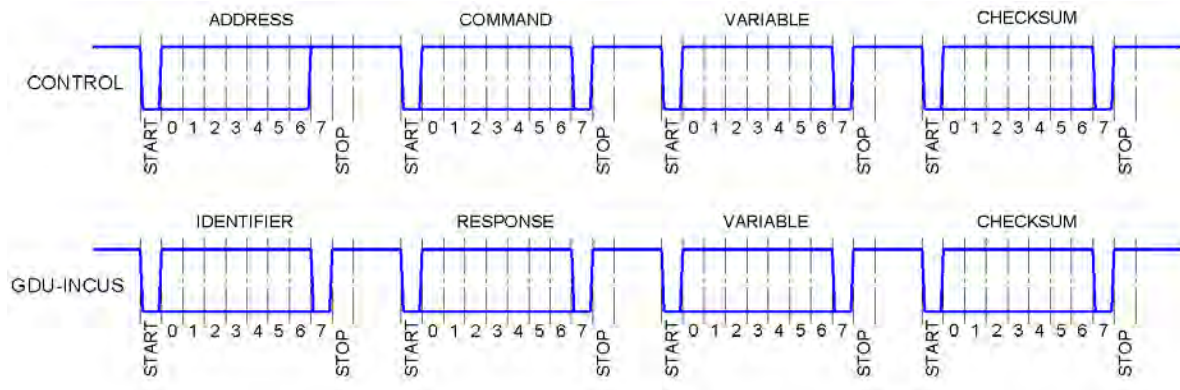

Figure 17

Figure 17 shows a typical set-up to allow fields to be distinguished. D7 is set in the control address field and cleared in all other fields.

See section 4. Customer Interface Commands for further details.

3.3.6.6. INFRA-RED

NSM-SU343 has Infra-red communication capability which allows all user variable functions to be changed and full functionality to be checked via a portable handheld device. The device can communicate over a distance of up to 8M allowing commissioning and maintenance procedures to be undertaken without the need of scaffolding.

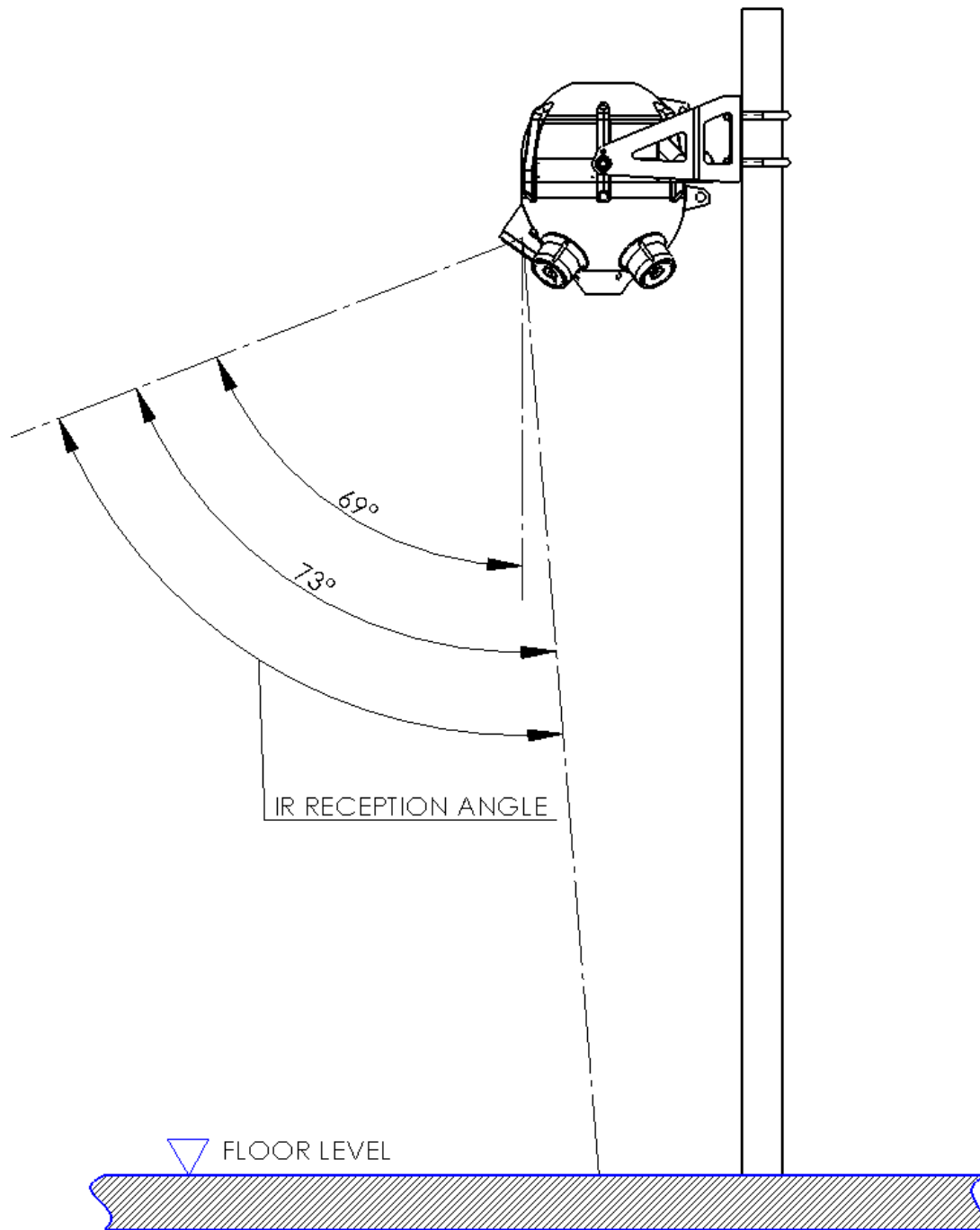

Figure 18

Figure 18 shows the extent of angular Infra-red reception when face on to the detector, angular reception from side to side is approximately 25° either side of the detector centre.

Ensure that the area in front of the detector has ease of access if Infra-red communication is required.

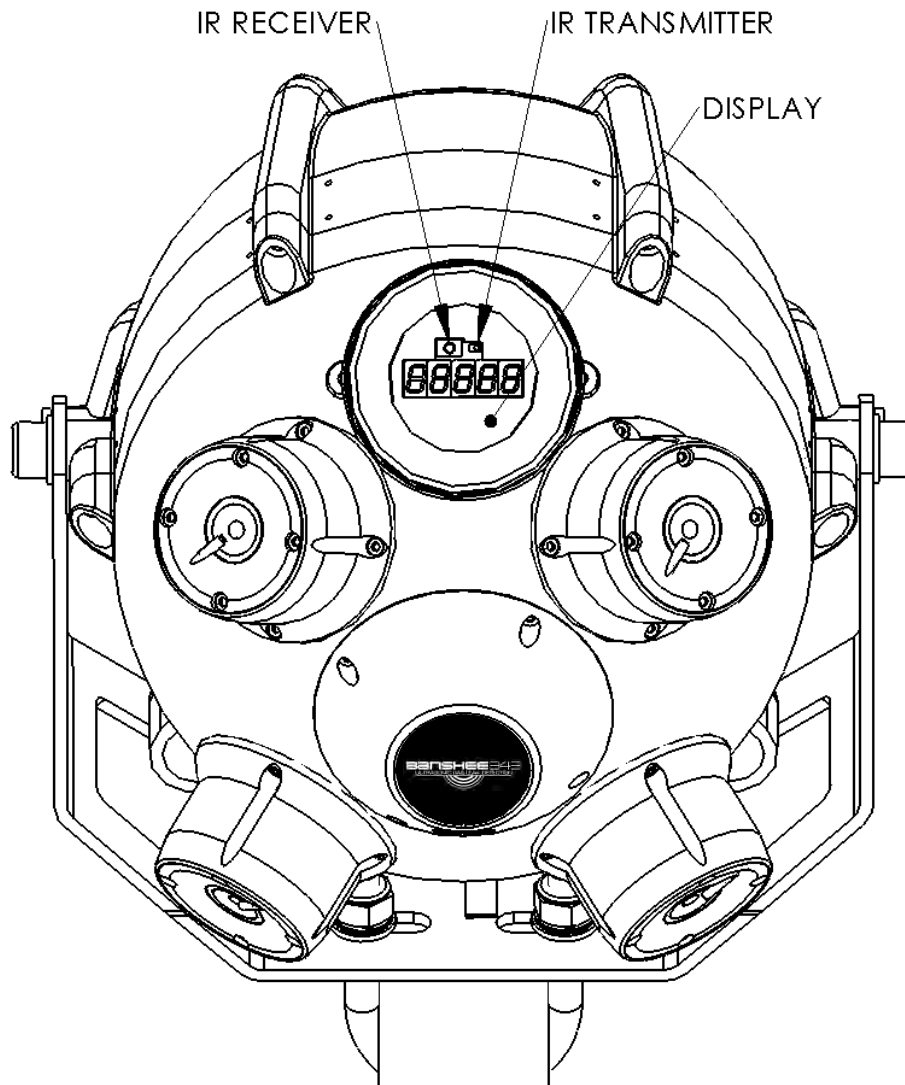

Figure 19

Figure 19 shows the position of the Infra-red receiver and transmitter with relation to the display. It is recommended that the display is visible to the user when using the Infra-red communicator to ensure correct communication.

3.4. MAINTENANCE PROCEDURES

3.4.1. HAND HELD TEST

GDU-01-TT Test Transmitter and NSM-SU343 Communicator can be used to emit an ultrasonic tone of 40kHz with a sound pressure level of 100dB at 1m (3ft). Using either handheld device makes testing the NSM-SU343 and other types of Ultrasonic detector quick and cost effective as it may be undertaken at floor level at distances of up to 8m (26ft) (dependant on background noise) provided line of sight with the sensor can be achieved. It is recommended that all alarms are disabled and the 4-20mA output is monitored from the control room or observed on the display. Testing is carried out to ensure that the sensors are functioning correctly in addition to any internal test function contained within NSM-SU343. It is recommended that a handheld test is undertaken in line with existing site maintenance procedures.

Note: ensure that any internal test functions are disabled or not activated when undertaking a handheld test to avoid spurious results.

3.4.2. VERIFICATION TEST

GDU-PTV Performance Target Verification Kit can be used to provide an accurate method to test both functionality and performance of ultrasonic gas detectors by generating a 'burst release' representative of that expected in the event of a gas leak. GDU-PTV should be used at the perimeter of the detector coverage to ensure that all leaks will be detected. It is recommended that all alarms are disabled and the 4-20mA output is monitored from the control room or observed on the display. Testing is carried out to ensure that the sensors are functioning correctly in addition to any internal test function contained within NSM-SU343 with respect to sensor response and coverage. It is recommended that a verification test is undertaken at installation and in line with existing site maintenance procedures.

4. CUSTOMER INTERFACE COMMANDS

4.1. RS485 DIGITAL INTERFACE

NSM-SU343 has a range of user changeable settings and defaults settings to allow complete flexibility for any installation environment.

4.1.1. CUSTOMER COMMANDS

NSM-SU343 starts in customer command mode to allow modification of user changeable settings which are detailed in the following table to allow the end user to write PC code to communicate with the detector. Net Safety Monitoring can also supply Graphical User Interface software that can be installed directly into the control PC for communication purposes.

Action	Master				NSM-SU343			
	Address	Command	Variable	Checksum	ID	Response	Variable	Checksum
Set Alarm Level (dB)	ADR	1	50 to 127 (50to127dB)	Checksum	ID	0	CONF	Checksum
Read Alarm Level (dB)	ADR	11	##	Checksum	ID	0	50 to 127 (50 to 127dB)	Checksum
Set Alarm Delay (10 & 1 second increments)	ADR	2	0 to 99 (0=0sec, 99=990sec) 100 to 127 (100=0sec, 127=27sec)	Checksum	ID	0	CONF	Checksum
Read Alarm Delay (10 & 1 second increments)	ADR	12	##	Checksum	ID	12	0 to 99 (0=0sec, 99=990sec) 100 to 127 (100=0sec, 127=27sec)	Checksum
Set Relays Normally Open / Normally Closed	ADR	3	0 NC 1 NO	Checksum	ID	0	CONF	Checksum
Read Relays Normally Open / Normally Closed	ADR	13	##	Checksum	ID	13	0 NC 1 NO	Checksum
Set Relays Latching	ADR	4	0 Off 1 On	Checksum	ID	0	CONF	Checksum
Read Relays Latching	ADR	14	##	Checksum	ID	14	0 Off 1 On	Checksum
Read Sound Level (dB)	ADR	20	##	Checksum	ID	20	47 to 200 (47 to 200dB)	Checksum
Read Alarm Data	ADR	21	##	Checksum	ID	21	Bit 0 = Low Supply Bit 1 = Test Bit 2 = Internal Fault Bit 3 = Inhibit	Checksum
Read Case Temperature	ADR	28	##	Checksum	ID	28	0 to 127 (-40 to 87°C)	Checksum
Read Supply Voltage	ADR	29	##	Checksum	ID	29	15 to 20 (15V to 30V)	Checksum
Read Heater Temperature	ADR	2A	##	Checksum	ID	2A	0 to 127 (-40 to 87°C)	Checksum
Set to Factory Defaults	ADR	30	##	Checksum	ID	0	CONF	Checksum
Reset Alarms	ADR	31	##	Checksum	ID	0	CONF	Checksum
Start Cleaning Cycle	ADR	32	##	Checksum	ID	0	CONF	Checksum
Set Pulsefilter (1sec increments)	ADR	40	0 – off 1 to 127 (sec)	Checksum	ID	0	CONF	Checksum
Read Pulsefilter (1sec increments)	ADR	41	##	Checksum	ID	41	0 – off 1 to 127 (sec)	Checksum
Set Display Brightness	ADR	42	0 – off 32 maximum	Checksum	ID	0	CONF	Checksum
Read Display Brightness	ADR	43	##	Checksum	ID	43	0 – off 32 maximum	Checksum
Set Heat Enable	ADR	44	0 – off 1 – auto 2 – on	Checksum	ID	44	CONF	Checksum
Read Heat Enable	ADR	45	##	Checksum	ID	45	0 – off 1 – auto 2 – on	Checksum

Action	Address	Command	Master		NSM-SU343			
			Variable	Checksum	ID	Response	Variable	Checksum
Set Cleaning Interval	ADR	46	0 – off 1 to 127 – on	Checksum	ID	0	CONF	Checksum
Read Cleaning Interval	ADR	47	##	Checksum	ID	47	0 – off 1 to 127 – on	Checksum
Set 'TeST' Display	ADR	48	0 – mA 1 – TEST	Checksum	ID	0	CONF	Checksum
Read 'TEST' Display	ADR	49	##	Checksum	ID	49	0 – mA 1 – TEST	Checksum
Initialize Customer Defaults	ADR	70	##	Checksum	ID	0	CONF	Checksum
Set Unit Address ID	ADR	71	1 to 31	Checksum	ID	0	CONF	Checksum

- Any Value

CONF – Confirmation (06 HEX)

Command and Response in HEX

5. WARNINGS



The specification and information included in this documentation may be subject to modification without notice to ensure certification compliance and improve functionality.

Please ensure that the following safety guidelines are observed at all times.

5.1. USE IN HAZARDOUS AREAS

NSM-SU343 should be installed and operated in compliance with the applicable standards relating to electrical installations in hazardous areas.

Please read the NSM-SU343 Ultrasonic Gas Leak Detector Operation Manual before installation.

All assembly work, electrical installations, operation and maintenance work must be performed by qualified personnel trained in handling products in hazardous areas.

All national regulations applicable to the installation, maintenance and repair of instruments in hazardous areas must be observed at all times.

Do not modify the enclosure or component parts as certification may be void.

The temperature class based on the ambient temperature must correspond to the temperature class on the EX type label.

The main enclosure should never be opened, certification and any warranties will be void.

Never open the terminal cover when an explosive atmosphere is present or when energised.

All enclosure and terminal cover fasteners to be tightened to a torque of 9Nm.

Only use a moist cloth or antistatic products to clean the display glass.

If NSM-SU343 is to be installed in areas with an ambient temperature greater than 60°C (158°F) ensure cable has a rating that is equal to or exceeds the proposed maximum working temperature.

Only certified, Ex d cable glands should be used in hazardous areas. Please refer to Cable gland manufacturers instructions for correct installation instructions.

All unused cable entries and glands in hazardous areas should be sealed using certified, type Ex d plugs. Please refer to Cable plug manufacturers instructions for correct installation instructions.

Earth wire to be connected to local earth. Ensure earth wire is attached using the supplied spring washer.

NSM-SU343 is certified to IP66/IP67 (EN60529), to ensure protection class is maintained the following installation the following points should be observed.

All cable glands should meet the appropriate Ingress Protection rating.

Always use cable glands suitable for the outside diameter of the cables used.

Tighten cable glands on cable to manufacturers instructions to ensure ingress protection rating.

Unused cable glands must be replaced by plugs.

The limit values for the maximum and minimum ambient temperatures should be observed at all times.

Additional protection may be required if the detector is installed in locations where it may be subjected to damage, excessive external stresses (vibration, heat, impact) or situated in environments with aggressive substances. Please contact Net Safety Monitoring or a Net Safety Monitoring representative if in doubt.

5.2. OWNERSHIP & CONFIDENTIALITY

All content contained in this document remains proprietary information of Net Safety Monitoring and is issued in strict confidence. Use, or reproduction of use, for reverse engineering, development or manufacture of hardware or software described herein is prohibited. No part of this document may be photocopied or reproduced without prior written consent of Net Safety Monitoring.

5.3. ACCESSORIES

Use only original spares and accessories to achieve certification compliance. Use of unapproved spares and accessories may result in detector failure and loss of warranties where applicable.

For a full list of accessories see section 6. Accessories and Spare Parts.

5.4. LIABILITY

Net Safety Monitoring Inc. declines all liability in the following events:

- Use of NSM-SU343 contrary to local and international health and safety laws.
- Incorrect installation, failure to, or incorrect use of the instructions given in this manual.
- Faults in the power supplied to NSM-SU343.
- Faults in the control room / panel connected to NSM-SU343.
- Modifying or tampering.
- Operations or maintenance carried out by un-authorized, non-qualified or unfit personnel.
- Operation outside of recommended usage limits.
- Use of spares and accessories that have not been approved by Net Safety Monitoring.

6. ACCESSORIES AND SPARE PARTS

6.1. ACCESSORIES

U-Bolt Kit.	Consists of two U-Bolts and all fasteners required to allow NSM-SU343 to be pole mounted using the standard mounting bracket. Size of U-Bolt should be specified at time of order.
Horizontal Mounting Kit	<p>Consists of mounting assembly and all fastening equipment required to allow the NSM-SU343 to be ceiling mounted using the standard mounting bracket.</p> <p>Note: the Horizontal Mounting Kit will also allow mounting to an overhead pole or pipe when used in conjunction with the U-Bolt Kit</p>
Vibration Plate.	<p>Consists of vibration plate, four dampers and fixings to allow NSM-SU343 to be mounted to vibrating surfaces using the standard mounting bracket. The Vibration Plate is available with 3 gradients of standard dampers to ensure the detector is shielded from interference and possible damage. The Vibration plate may be used in conjunction with the U-Bolt Kit and the Horizontal Mounting Kit.</p> <p>Corrosive proof dampers are available in 3 gradients for extreme environments. Contact Net Safety Monitoring or a Net Safety Monitoring representative for exact requirements.</p>
Ex e Junction Box.	Consists of Ex e certified Junction Box, standard mounting bracket adaptor and fasteners, Ex d certified cable glands and connecting cable to allow the detector to be installed on site using Ex e standards and certified components.
Test Transmitter.	Consists of a handheld rechargeable ultrasonic sound emitter with carry case, charger and shoulder strap to allow remote independent testing of any ultrasonic gas leak detector from floor level. Note: NSM-01-TT is not hazardous area approved and will require a hot work permit.
Mapping Tool.	Consists of a handheld rechargeable ultrasonic sound receiver with carry case, charger and shoulder strap to allow background ultrasonic noise levels to be determined. Can also be used to pinpoint exact leak position once a leak has been identified using fixed forms of detector. Note: NSM-MT-01 is not hazardous area approved and will require a hot work permit.
GUI Software Package.	Graphical User Interface software that allows communication with the NSM-SU343 from the control room. User can obtain detector status and operating conditions, change parameters and force self-test

functionality.

**Performance Target
Verification Kit.**

Consists of Cylinder trolley with cylinder retainers, 2 off 150 bar Nitrogen (N₂) cylinders, high pressure hose from cylinders to regulator, high pressure regulator, high pressure hose from regulator release pressure gauge, shut off valve and release nozzle to allow performance and verification testing of installed Ultrasonic Detectors by releasing an actual gas release.

Please refer to individual accessory datasheets for further information or contact Net Safety Monitoring or a Net Safety Monitoring representative

6.2. SPARE PARTS

Mounting Bracket.

Standard mounting bracket, allows NSM-SU343 to be mounted to a flat surface or other Net Safety Monitoring supplied mounting accessories. Consists of a standard mounting bracket and fasteners required to fix to the NSM-SU343.

Pump.

Complete assembled H₂S pump unit with H₂S resistant seals and diaphragm.

Distributor O Ring Kit.

H₂S resistant distributor O ring and sealing washer.

External Earth Kit.

Fastener and washer kit for external earth point.

Enclosure O Ring Kit.

H₂S resistant enclosure O ring kit consisting of terminal and pump cover O rings.

Enclosure Fastener Kits.

Terminal cover fastener kit. Consists of 6 terminal cover fasteners and retaining washers.

Pump compartment fastener kit. Consists of 4 pump compartment fasteners and pump compartment sealing washer.

Terminal Cover O Ring
Upper

Replacement terminal cover O ring for upper position, H₂S resistant.

Terminal Cover O Ring
Lower

Replacement terminal cover O ring for lower position, H₂S resistant.

Please refer to individual spare part installation sheets for further information.

6.3. ORDERING INFORMATION

Ordering Information. NSM-SU343 Series of Ultrasonic Gas Leak Detectors										
Variant No.	1-10	11	12	13	14	15	16	17	18	
NSM Part Number	NSM-SU343-	#	#	#	#	#	#	#	#	#
Enclosure Material										
Aluminum		A								
316 Stainless Steel		S								
Communications										
Continuous 4-20mA Output										
4-20mA = 40 to 200dB, Fault Output Option 1 & RS485 Digital Interface			0	1						
4-20mA = 40 to 200dB, Fault Output Option 2 & RS485 Digital Interface			0	2						
Stepped 4-20mA Output										
4mA Normal Output, 12mA Alarm Output, Fault Output Option 1 & RS485 Digital Interface			1	1						
4mA Normal Output, 12mA Alarm Output, Fault Output Option 2 & RS485 Digital Interface			1	2						
4mA Normal Output, 20mA Alarm Output, Fault Output Option 1 & RS485 Digital Interface			1	3						
4mA Normal Output, 20mA Alarm Output, Fault Output Option 2 & RS485 Digital Interface			1	4						
Sealing Options										
H2S Resistant. IP66/67						1				
Mounting Options										
Standard										
Wall Mounting Bracket							0			
U-Bolts										
U-Bolt Kit for 1" Pipe								1		
U-Bolt Kit for 2" Pipe								2		
Horizontal Mounting										
Ceiling Mounted								4		
Overhead Pipe Mounting for 1" Pipe								5		
Overhead Pipe Mounting for 2" Pipe								6		
Vibration Plate										
Standard										
No Vibration Damping								0		
Non Corrosive Environment										
Low Frequency Damping								1		
Mid Frequency Damping								2		
High Frequency Damping								3		
Corrosive Environment										
Low Frequency Damping								4		
Mid Frequency Damping								5		
High Frequency Damping								6		
External Cabling										
Standard. Ex d										
M20 x 1 off									1	0
M20 x 2 off									2	0
M25 x 1 off									3	0
M25 x 2 off									4	0
1/2" NPT x 1 off									5	0
1/2" NPT x 2 off									6	0
3/4" NPT x 1 off									7	0
3/4" NPT x 2 off									8	0
Ex e Junction Box and Mounting Bracket										
Note: 1-8 in first column represents JB cable entry as per standard Ex d designation									1-8	1

Example: NSM-SU343-A0211061 designates an Aluminum enclosure, continuous 4-20mA with Fault option 2 & RS485 Digital Interface, H₂S resistant seals and pump unit, 1" pipe U-Bolt kit, no vibration plate and an Ex e Junction Box with 2 x 1/2" NPT cable entries.

6.4. ACCESSORIES

Description	Part Number
Test Transmitter. Handheld rechargeable Ultrasonic Sound Emitter	NSM-01-TT
Mapping Tool. Handheld rechargeable Ultrasonic Sound Receiver	NSM-MT-01
GUI Software Package. Graphical User Interface for RS485 communication	NSM-SU343-GUI
Performance Target Verification Kit	NSM-PTV

6.5. SPARE PARTS

Description	Part number
Mounting Bracket. Replacement standard Mounting Bracket for flat surface mounting	NSM-SU343-MTBR
H ₂ S Pump. Replacement Pump Unit with H ₂ S resistant seals and diaphragm	NSM-SU343-HSPU
H ₂ S Distributor O ring Kit. Replacement H ₂ S resistant O ring and sealing washer	NSM-SU343-DHOR
External Earth Kit. Replacement fastener and washer kit for external earth point	NSM-SU343-EXEK
H ₂ S Enclosure O Ring Kit. Replacement H ₂ S terminal and pump cover O rings	NSM-SU343-EHOR
Terminal Fastener Kit. Replacement Terminal Cover fasteners and retaining washers	NSM-SU343-TCFK
Pump Compartment Fastener Kit. Replacement Pump Compartment fasteners.	NSM-SU343-PCFK
Terminal Cover O Ring Upper H ₂ S Resistant	NSM-02-TCU-H2
Terminal Cover O Ring Lower H ₂ S Resistant	NSM-02-TCL-H2

Blank Page

Net Safety Monitoring, Inc.
2721 Hopewell Place NE, Calgary, AB Canada T1Y 7J7
1-866-FIREGAS (347-3427) | ph. (403) 219-0688 | fx. (403) 219-0694
<http://www.net-safety.com> | e-mail: nsmsales@net-safety.com

PRODUCT SERVICES CONTACT INFORMATION
Telephone [8am - 5pm MDT]: (403) 769-6074 | (403) 717-8219
Fax: (403) 219-0694 | e-mail: productservices@net-safety.com
http://www.net-safety.com/service/product_services.html

