

Operating Instructions

Tankside Monitor NRF81

Tank Gauging

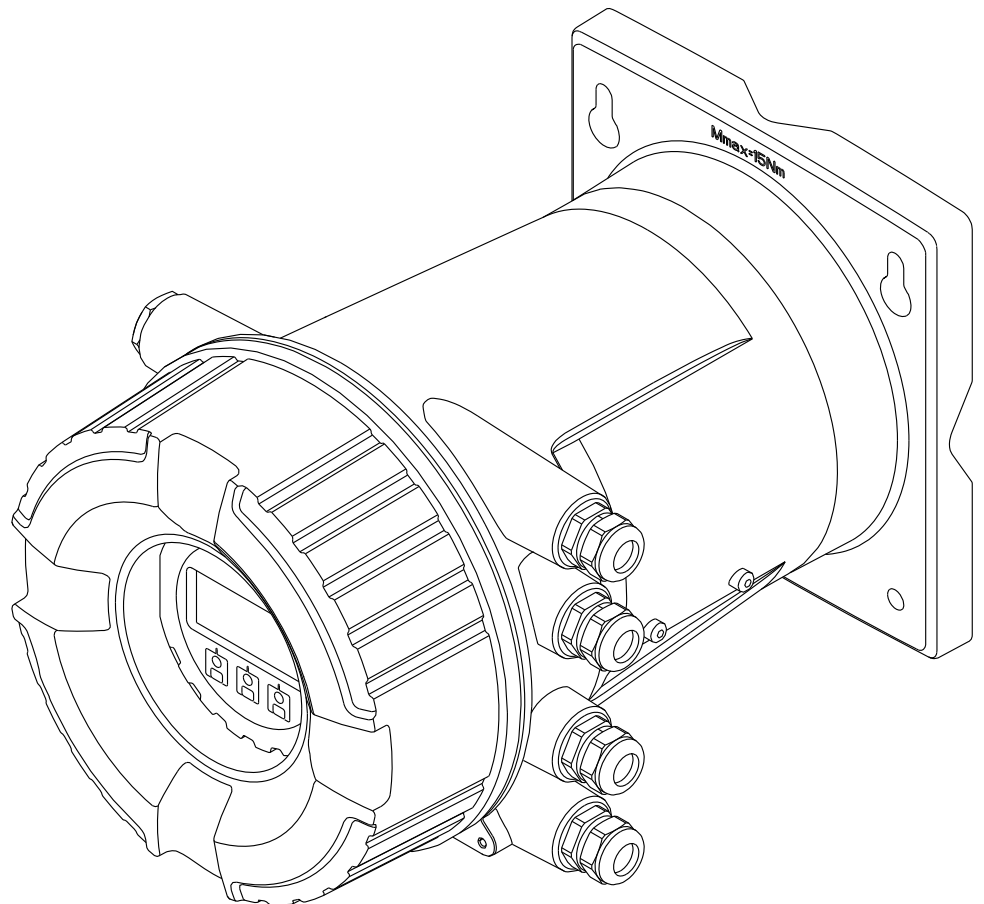



A0023555

Table of contents

1	About this document	4	9.2	Configuring the tank gauging application	57
1.1	Document function	4	9.3	Advanced settings	83
1.2	Symbols	4	9.4	Simulation	83
1.3	Documentation	7	9.5	Protecting settings from unauthorized access	83
1.4	Registered trademarks	9			
2	Basic safety instructions	10	10	Operation	84
2.1	Requirements for the personnel	10	10.1	Reading off the device locking status	84
2.2	Designated use	10	10.2	Reading off measured values	84
2.3	Workplace safety	10			
2.4	Operational safety	11	11	Diagnostics and troubleshooting ...	85
2.5	Product safety	11	11.1	General trouble shooting	85
3	Product description	12	11.2	Diagnostic information on local display	86
3.1	Product design	12	11.3	Diagnostic information in FieldCare	89
4	Incoming acceptance and product identification	13	11.4	Overview of the diagnostic messages	91
4.1	Incoming acceptance	13	11.5	Diagnostic list	97
4.2	Product identification	13	11.6	Reset measuring device	98
4.3	Storage and transport	15	11.7	Device information	98
5	Installation	16	11.8	Firmware history	98
5.1	Installation conditions	16	12	Maintenance	99
5.2	Post-installation check	17	12.1	Maintenance tasks	99
6	Electrical connection	18	12.2	Endress+Hauser services	99
6.1	Terminal assignment	18	13	Repair	100
6.2	Connecting requirements	34	13.1	General information on repairs	100
6.3	Ensuring the degree of protection	35	13.2	Spare parts	100
6.4	Post-connection check	35	13.3	Endress+Hauser services	101
7	Operability	36	13.4	Return	101
7.1	Overview of the operation options	36	13.5	Disposal	101
7.2	Structure and function of the operating menu	37	14	Accessories	102
7.3	Access to the operating menu via the local or remote display and operating module	38	14.1	Device-specific accessories	102
7.4	Access to the operating menu via the service interface and FieldCare	50	14.2	Communication-specific accessories	103
7.5	Access to the operating menu via Tankvision Tank Scanner NXA820 and FieldCare	51	14.3	Service-specific accessories	103
8	System integration	54	14.4	System components	103
8.1	Overview of the Device Description files (DTM)	54	15	Operating menu	104
9	Commissioning	55	15.1	Overview of the operating menu	104
9.1	Initial settings	55	15.2	"Operation" menu	112
			15.3	"Setup" menu	121
			15.4	"Diagnostics" menu	236
			Index	245	





1 About this document

1.1 Document function







These Operating Instructions contain all the information that is required in various phases of the life cycle of the device: from product identification, incoming acceptance and storage, to mounting, connection, operation and commissioning through to troubleshooting, maintenance and disposal.

1.2 Symbols





1.2.1 Safety symbols

Symbol	Meaning
	DANGER! This symbol alerts you to a dangerous situation. Failure to avoid this situation will result in serious or fatal injury.
	WARNING! This symbol alerts you to a dangerous situation. Failure to avoid this situation can result in serious or fatal injury.
	CAUTION! This symbol alerts you to a dangerous situation. Failure to avoid this situation can result in minor or medium injury.
	NOTE! This symbol contains information on procedures and other facts which do not result in personal injury.





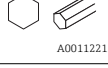







1.2.2 Electrical symbols

Symbol	Meaning
	Direct current
	Alternating current
	Direct current and alternating current
	Ground connection A grounded terminal which, as far as the operator is concerned, is grounded via a grounding system.
	Protective ground connection A terminal which must be connected to ground prior to establishing any other connections.
	Equipotential connection A connection that has to be connected to the plant grounding system: This may be a potential equalization line or a star grounding system depending on national or company codes of practice.

1.2.3 Tool symbols



Symbol	Meaning
 A0013442	Torx screwdriver
 A0011220	Flat blade screwdriver
 A0011219	Cross-head screwdriver
 A0011221	Allen key
 A0011222	Hexagon wrench

1.2.4 Symbols for certain types of information



Symbol	Meaning
	Permitted Procedures, processes or actions that are permitted.
	Preferred Procedures, processes or actions that are preferred.
	Forbidden Procedures, processes or actions that are forbidden.
	Tip Indicates additional information.
	Reference to documentation
	Reference to page
	Reference to graphic
	Notice or individual step to be observed
	Series of steps
	Result of a step
	Help in the event of a problem
	Visual inspection

1.2.5 Symbols in graphics

Symbol	Meaning
1, 2, 3 ...	Item numbers
	Series of steps
A, B, C, ...	Views
A-A, B-B, C-C, ...	Sections

Symbol	Meaning
	Hazardous area Indicates a hazardous area.
	Safe area (non-hazardous area) Indicates the non-hazardous area.

1.2.6 Symbols at the device

Symbol	Meaning
	Safety instructions Observe the safety instructions contained in the associated Operating Instructions.
	Temperature resistance of the connection cables Specifies the minimum value of the temperature resistance of the connection cables.

1.3 Documentation

 For an overview of the scope of the associated Technical Documentation, refer to the following:

- The *W@M Device Viewer* : Enter the serial number from the nameplate (www.endress.com/deviceviewer)
- The *Endress+Hauser Operations App*: Enter the serial number from the nameplate or scan the 2-D matrix code (QR code) on the nameplate.

1.3.1 Technical Information (TI)

The Technical Information contains all the technical data on the device and provides an overview of the accessories and other products that can be ordered for the device.

Device	Technical Information
Tankside Monitor NRF81	TI01251G

1.3.2 Brief Operating Instructions (KA)

The Brief Operating Instructions contain all the essential information from incoming acceptance to initial commissioning.

Device	Brief Operating Instructions
Tankside Monitor NRF81	KA01209G

1.3.3 Operating Instructions (BA)

The Operating Instructions contain all the information that is required in various phases of the life cycle of the device: from product identification, incoming acceptance and storage, to mounting, connection, operation and commissioning through to troubleshooting, maintenance and disposal.

It also contains a detailed explanation of each individual parameter in the operating menu (except the **Expert** menu). The description is aimed at those who work with the device over the entire life cycle and perform specific configurations.

Device	Operating Instructions
Tankside Monitor NRF81	BA01465G

1.3.4 Description of Device Parameters (GP)

The Description of Device Parameters provides a detailed explanation of each individual parameter in the 2nd part of the operating menu: the **Expert** menu. It contains all the device parameters and allows direct access to the parameters by entering a specific code. The description is aimed at those who work with the device over the entire life cycle and perform specific configurations.

Device	Description of Device Parameters
Tankside Monitor NRF81	GP01083G

1.3.5 Safety instructions (XA)

Ordering feature 010 "Approval"	Meaning	XA
BA	ATEX II 2 (1)G Ex db [ia Ga] IIC T6 Gb	XA01531G
FD	FM C/US XP-AIS Cl.I Div.1 Gr.BCD T6 AEx d[ia] IIC T6	XA01532G
GA	EAC Ex db[ia Ga] IIC T6 Gb	XA01701G
IA	IEC Ex db [ia Ga] IIC T6 Gb	XA01531G
KA	KC Ex db[ia Ga] IIC T6 Gb	in preparation
MA	INMETRO Ex db[ia Ga] IIC T6 Gb	in preparation
NA	NEPSI Ex db[ia Ga] IIC T6 Gb	XA01752G
TA	TIIS Ex d[ia] IIC T6 Ga/Gb	in preparation

1.4 Registered trademarks

FieldCare®

Registered trademark of the Endress+Hauser Process Solutions AG, Reinach, Switzerland

MODBUS®

Registered trademark of the MODBUS-IDA, Hopkinton, MA, USA

2 Basic safety instructions

2.1 Requirements for the personnel

The personnel for installation, commissioning, diagnostics and maintenance must fulfill the following requirements:

- ▶ Trained, qualified specialists must have a relevant qualification for this specific function and task.
- ▶ Are authorized by the plant owner/operator.
- ▶ Are familiar with federal/national regulations.
- ▶ Before starting work, read and understand the instructions in the manual and supplementary documentation as well as the certificates (depending on the application).
- ▶ Follow instructions and comply with basic conditions.

The operating personnel must fulfill the following requirements:

- ▶ Are instructed and authorized according to the requirements of the task by the facility's owner-operator.
- ▶ Follow the instructions in this manual.

2.2 Designated use

Application and measured materials

The device described in these Operating Instructions is a monitoring unit for use with the Endress+Hauser Micropilot M and Micropilot S-series radars and other HART compatible devices. Mounted at the tank side, it provides indication of measured data, allows configuration and supplies intrinsically safe (i.s.) or explosion proof (XP) power to the connected sensors on the tank. Various industry standard digital gauging communication protocols support integration into open architecture tank gauging and inventory systems.

Measuring devices for use in hazardous areas, in hygienic applications or in applications where there is an increased risk due to process pressure, are labeled accordingly on the nameplate.

To ensure that the measuring device remains in proper condition for the operation time:

- ▶ Only use the measuring device in full compliance with the data on the nameplate and the general conditions listed in the Operating Instructions and supplementary documentation.
- ▶ Check the nameplate to verify if the device ordered can be put to its intended use in the approval-related area (e.g. explosion protection, pressure vessel safety).
- ▶ If the measuring device is not operated at atmospheric temperature, compliance with the relevant basic conditions specified in the associated device documentation is absolutely essential.
- ▶ Protect the measuring device permanently against corrosion from environmental influences.
- ▶ Observe the limit values in the "Technical Information".

The manufacturer is not liable for damage caused by improper or non-designated use.

2.3 Workplace safety

For work on and with the device:

- ▶ Wear the required personal protective equipment according to federal/national regulations.

2.4 Operational safety

Risk of injury.

- ▶ Operate the device in proper technical condition and fail-safe condition only.
- ▶ The operator is responsible for interference-free operation of the device.

Conversions to the device

Unauthorized modifications to the device are not permitted and can lead to unforeseeable dangers.

- ▶ If, despite this, modifications are required, consult with the manufacturer.

Repair

To ensure continued operational safety and reliability,

- ▶ Carry out repairs on the device only if they are expressly permitted.
- ▶ Observe federal/national regulations pertaining to repair of an electrical device.
- ▶ Use original spare parts and accessories from the manufacturer only.

Hazardous area

To eliminate a danger for persons or for the facility when the device is used in the hazardous area (e.g. explosion protection, pressure vessel safety):

- ▶ Based on the nameplate, check whether the ordered device is permitted for the intended use in the hazardous area.
- ▶ Observe the specifications in the separate supplementary documentation that is an integral part of these Instructions.

2.5 Product safety

This measuring device is designed in accordance with good engineering practice to meet state-of-the-art safety requirements, has been tested, and left the factory in a condition in which it is safe to operate. It meets general safety standards and legal requirements.

2.5.1 CE mark

The measuring system meets the legal requirements of the applicable EC guidelines. These are listed in the corresponding EC Declaration of Conformity together with the standards applied.

Endress+Hauser confirms successful testing of the device by affixing to it the CE mark.

3 Product description

3.1 Product design

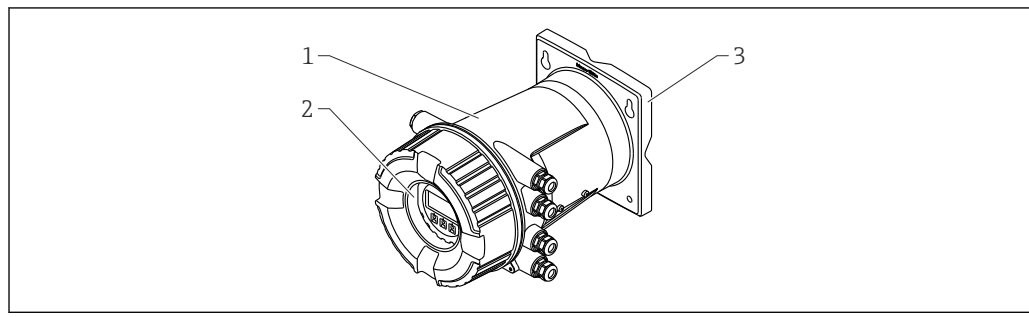

A0027767

 1 Design of Tankside Monitor NRF81

1 Housing

2 Display and operating module (can be operated without opening the cover)

3 Mounting plate for wall or pipe mounting

4 Incoming acceptance and product identification

4.1 Incoming acceptance

Upon receipt of the goods check the following:

- Are the order codes on the delivery note and the product sticker identical?
- Are the goods undamaged?
- Do the nameplate data match the ordering information on the delivery note?
- If required (see nameplate): Are the Safety Instructions (XA) enclosed?



If one of these conditions is not satisfied, contact your Endress+Hauser Sales Center.

4.2 Product identification

The following options are available for identification of the measuring device:

- Nameplate specifications
- Extended order code with breakdown of the device features on the delivery note
- Enter serial numbers from nameplates in *W@M Device Viewer* (www.endress.com/deviceviewer): All information about the measuring device is displayed.
- Enter the serial number from the nameplates into the *Endress+Hauser Operations App* or scan the 2-D matrix code (QR code) on the nameplate with the *Endress+Hauser Operations App*: all the information for the measuring device is displayed.

For an overview of the scope of the associated Technical Documentation, refer to the following:

- The *W@M Device Viewer*: Enter the serial number from the nameplate (www.endress.com/deviceviewer)
- The *Endress+Hauser Operations App*: Enter the serial number from the nameplate or scan the 2-D matrix code (QR code) on the nameplate.

4.2.1 Nameplate

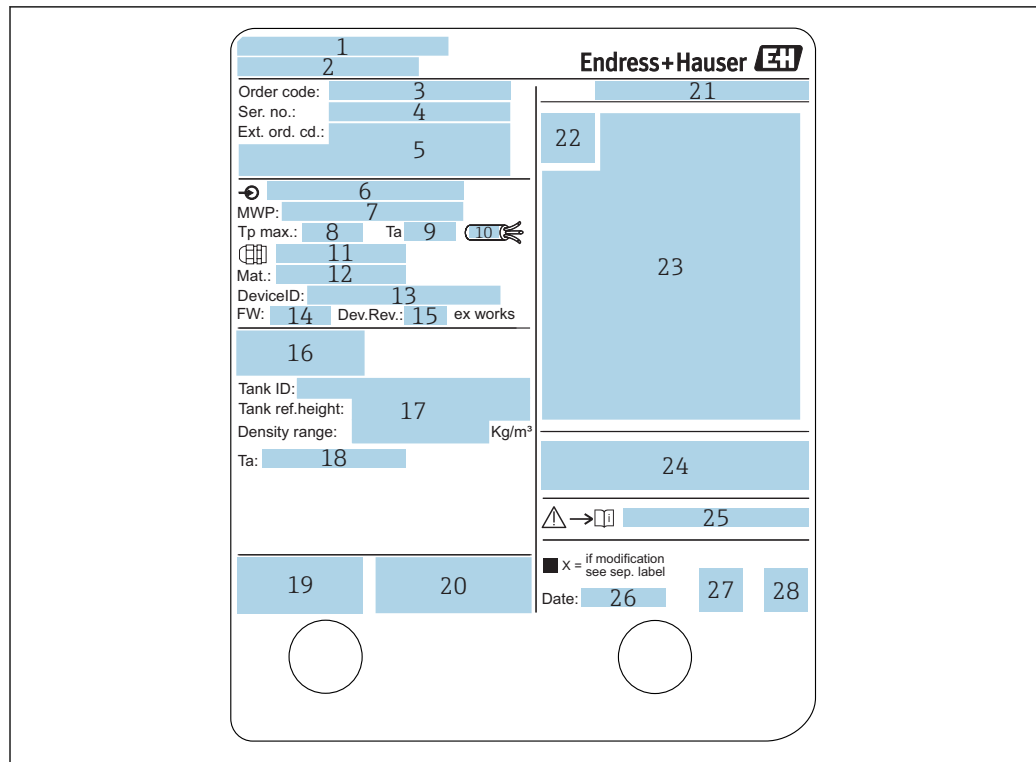

A0027791

2 Nameplate

- 1 Manufacturer address
- 2 Device name
- 3 Order code
- 4 Serial number
- 5 Extended order code
- 6 Supply voltage
- 7 Maximum process pressure
- 8 Maximum process temperature
- 9 Permitted ambient temperature (T_a)
- 10 Temperature resistance of cable
- 11 Thread for cable entry
- 12 Material in contact with process
- 13 Device ID
- 14 Firmware version
- 15 Device revision
- 16 Metrology certification numbers
- 17 Customized parametrization data
- 18 Ambient temperature range
- 19 CE mark / C-tick mark
- 20 Additional information on the device version
- 21 Ingress protection
- 22 Certificate symbol
- 23 Data concerning the Ex approval
- 24 General certificate of approval
- 25 Associated Safety Instructions (XA)
- 26 Manufacturing date
- 27 RoHS mark
- 28 QR code for the Endress+Hauser Operations App

4.2.2 Manufacturer address

Endress+Hauser SE+Co. KG
 Hauptstraße 1
 79689 Maulburg, Germany

Address of the manufacturing plant: See nameplate.

4.3 Storage and transport

4.3.1 Storage conditions

- Storage temperature: -50 to +80 °C (-58 to +176 °F)
- Store the device in its original packaging.

4.3.2 Transport

NOTICE

Risk of injury

- ▶ Transport the measuring device to the measuring point in its original packaging.
- ▶ Take into account the mass center of the device in order to avoid unintended tilting.
- ▶ Comply with the safety instructions, transport conditions for devices over 18kg (39.6lbs) (IEC61010).

5 Installation

5.1 Installation conditions

5.1.1 Wall mounting

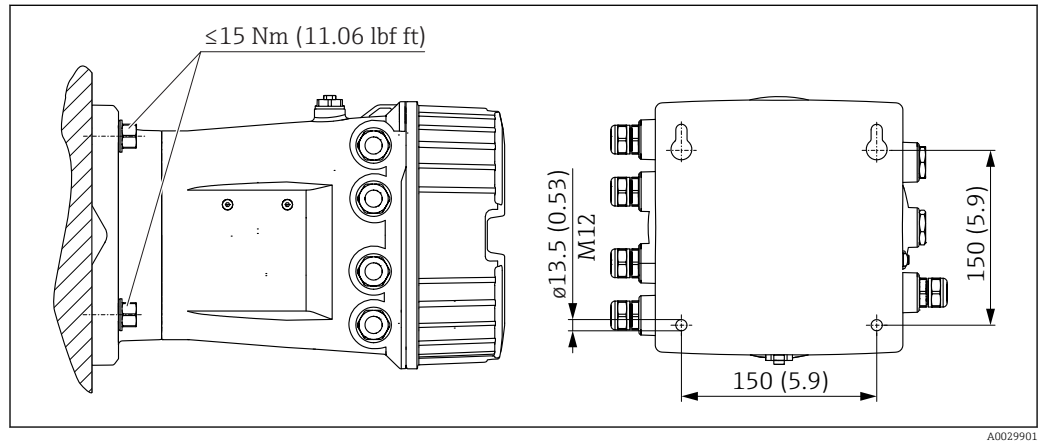

3 Wall mounting of the Tankside Monitor

5.1.2 Pipe mounting

Ordering feature 620 "Accessory enclosed"	Mounting kit
PV	Mounting kit, pipe, DN32-50 (1-1/4" - 2")
PW	Mounting kit, pipe, DN80 (3")

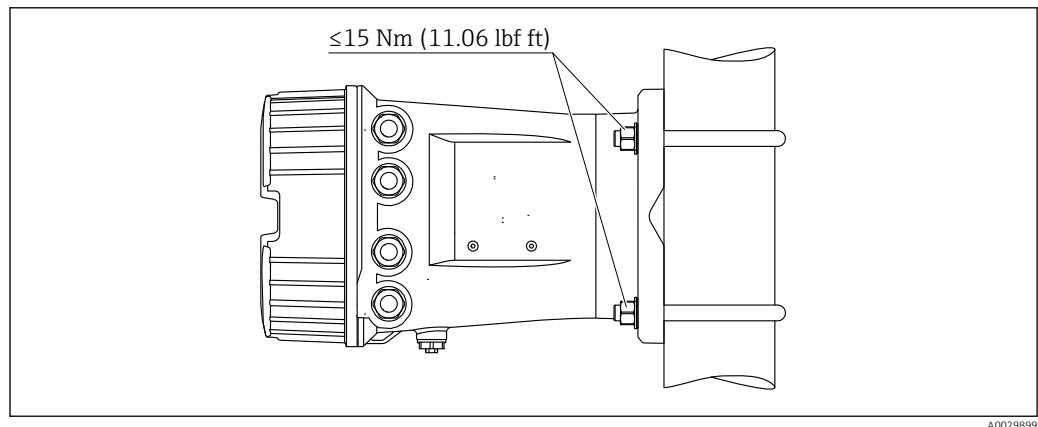

4 Mounting of the Tankside Monitor at a vertical pipe

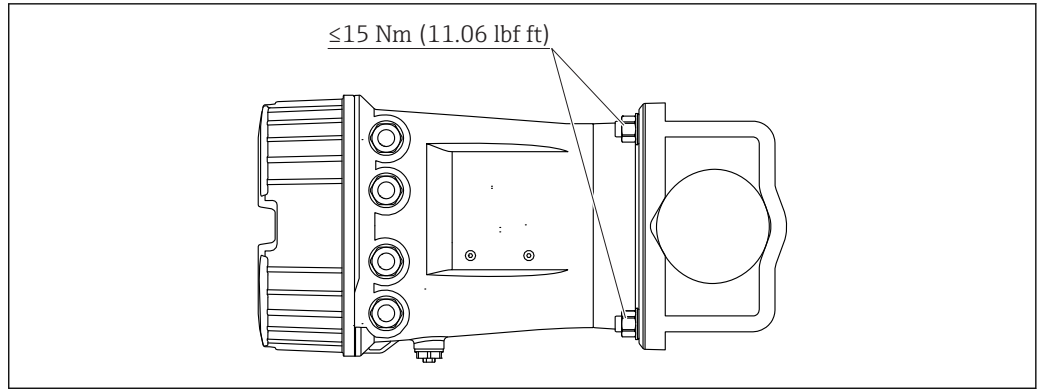

A0029900

5 Mounting of the Tankside Monitor at a horizontal pipe

5.2 Post-installation check

<input type="radio"/>	Is the device undamaged (visual inspection)?
<input type="radio"/>	Does the device conform to the measuring point specifications? For example: <ul style="list-style-type: none"> ▪ Process temperature ▪ Process pressure (refer to the chapter on "Material load curves" of the "Technical Information" document) ▪ Ambient temperature range ▪ Measuring range
<input type="radio"/>	Are the measuring point identification and labeling correct (visual inspection)?
<input type="radio"/>	Is the device adequately protected from precipitation and direct sunlight?

6 Electrical connection

6.1 Terminal assignment

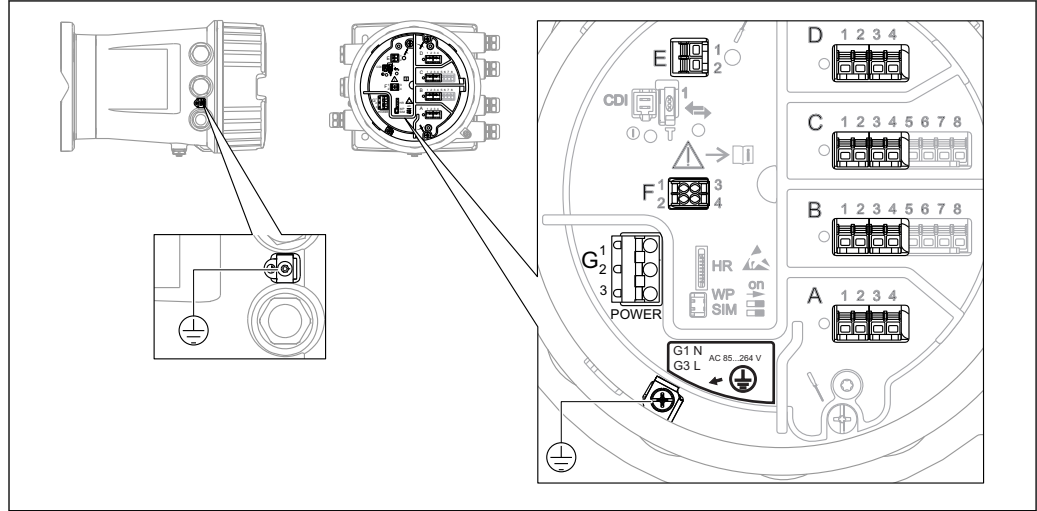

6 Terminal compartment (typical example) and ground terminals

A0027362

Terminal area	Module
A/B/C/D (slots for I/O modules)	<p>Up to four I/O modules, depending on the order code</p> <ul style="list-style-type: none"> Modules with four terminals can be in any of these slots. Modules with eight terminals can be in slot B or C. <p>i The exact assignment of the modules to the slots is dependent on the device version → 21.</p>
E	<p>HART Ex i/IS interface</p> <ul style="list-style-type: none"> E1: H+ E2: H-
F	<p>Remote display</p> <ul style="list-style-type: none"> F1: V_{CC} (connect to terminal 81 of the remote display) F2: Signal B (connect to terminal 84 of the remote display) F3: Signal A (connect to terminal 83 of the remote display) F4: Gnd (connect to terminal 82 of the remote display)
G	<p>Power supply: 85 to 264 V_{AC}</p> <ul style="list-style-type: none"> G1: N G2: not connected G3: L
	<p>Protective ground connection (M4 screw)</p> <p>A0018339</p>

6.1.1 Power supply

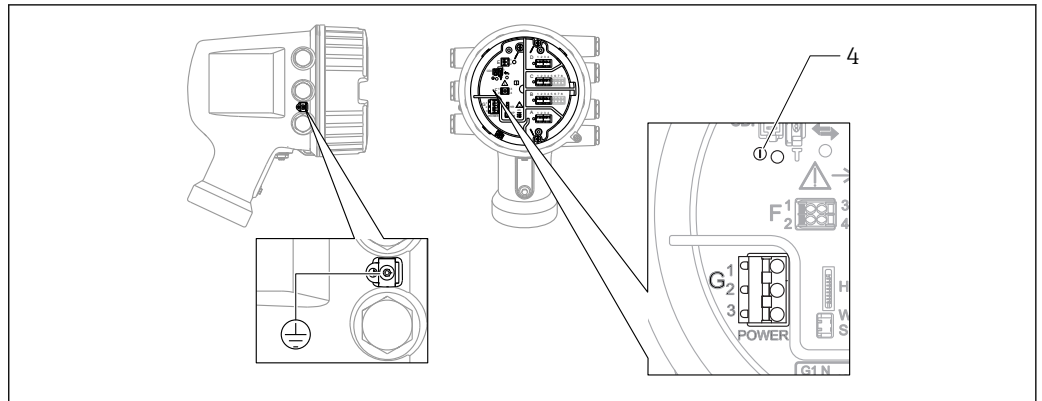

- G1 N
- G2 not connected
- G3 L
- 4 Green LED: indicates power supply

Supply voltage

85 to 264 V_{AC}, 50/60 Hz, 28.8 VA ¹⁾

i The supply voltage is also indicated on the nameplate.

6.1.2 Remote display and operating module DKX001

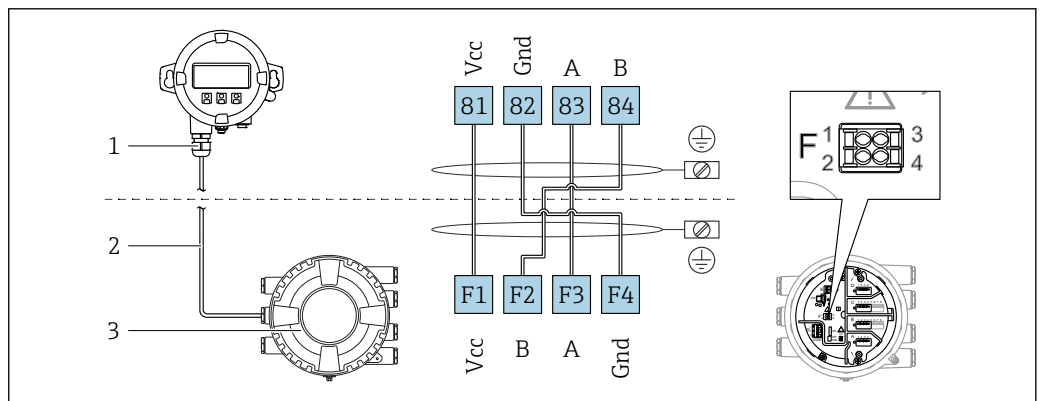

7 Connection of the remote display and operating module DKX001 to the Tank Gauging device (NMR8x, NMS8x or NRF8x)

- 1 Remote display and operating module
- 2 Connecting cable
- 3 Tank Gauging device (NMR8x, NMS8x or NRF8x)

i The remote display and operating module DKX001 is available as an accessory. For details refer to SDO1763D.

- i**
 - The measured value is indicated on the DKX001 and on the local display and operating module simultaneously.
 - The operating menu cannot be accessed on both modules at the same time. If the operating menu is entered in one of these modules, the other module is automatically locked. This locking remains active until the menu is closed in the first module (back to measured value display).

1) maximum value; actual value depending on modules installed. 28.8 VA includes the nominal power, and the cabling specification has to meet this value. On the other hand, the effective power consumption is 12 W.

6.1.3 HART Ex i/IS interface

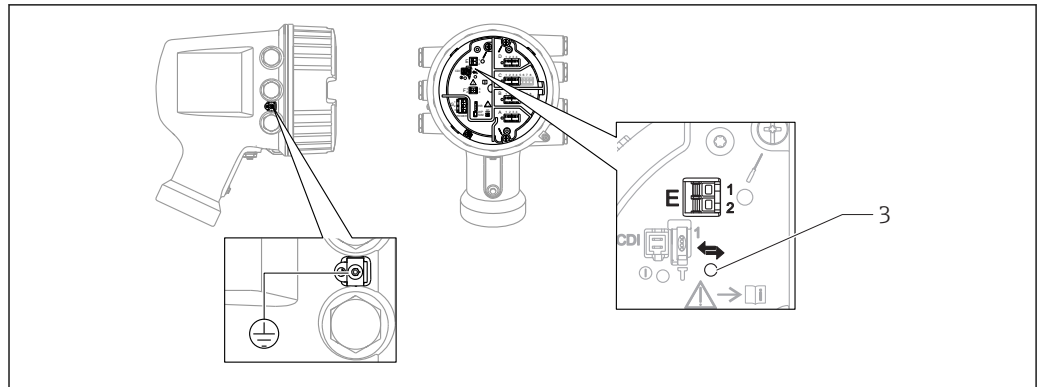

A0033414

- E1 H+
- E2 H-
- 3 Orange LED: indicates data communication

i This interface always operates as the main HART master for connected HART slave transmitters. The Analog I/O modules, on the other hand, can be configured as a HART master or slave → 28 → 30.

6.1.4 Slots for I/O modules

The terminal compartment contains four slots (A, B, C and D) for I/O modules. Depending on the device version (ordering features 040, 050 and 060) these slots contain different I/O modules. The table below shows which module is located in which slot for a specific device version.

i The slot assignment for the device is also indicated on a label attached to the back cover of the display module.

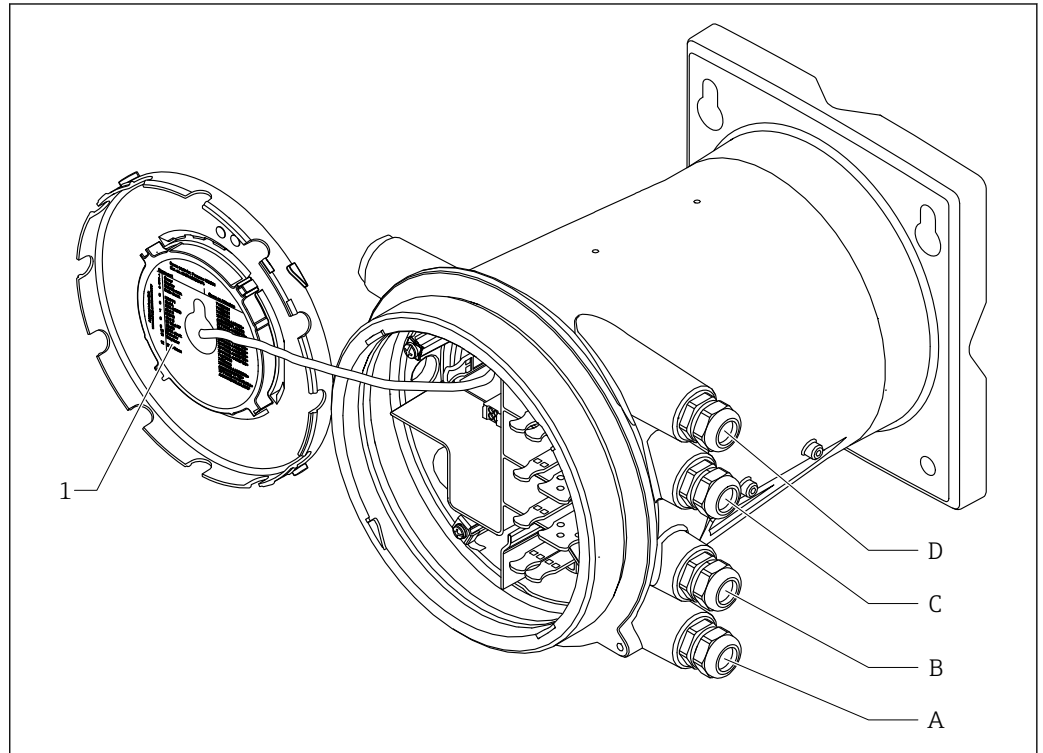

- 1 Label showing (among other things) the modules in the slots A to D.
- A Cable entry for slot A
- B Cable entry for slot B
- C Cable entry for slot C
- D Cable entry for slot D

A0030069

"Primary Output" (040) = "Modbus" (A1)

Ordering feature			Terminal area			
NRF81 - xxxx <u>XX</u> <u>XX</u> <u>XX</u> ... 040 050 060						
040 Primary Output	050 Secondary IO Analog	060 Secondary IO Digital Ex d/XP				
A1	X0	X0	Modbus	-	-	-
A1	X0	A1	Modbus	-	-	Digital
A1	X0	A2	Modbus	-	Digital	Digital
A1	X0	A3	Modbus	Digital	Digital	Digital
A1	X0	B1	Modbus	Modbus	-	-
A1	X0	B2	Modbus	Modbus	-	Digital
A1	X0	B3	Modbus	Modbus	Digital	Digital
A1	A1	X0	Modbus	Analog Ex d/XP	-	-
A1	A1	A1	Modbus	Analog Ex d/XP	-	Digital
A1	A1	A2	Modbus	Analog Ex d/XP	Digital	Digital
A1	A1	B1	Modbus	Modbus	Analog Ex d/XP	-
A1	A1	B2	Modbus	Modbus	Analog Ex d/XP	Digital
A1	A2	X0	Modbus	Analog Ex d/XP	Analog Ex d/XP	-
A1	A2	A1	Modbus	Analog Ex d/XP	Analog Ex d/XP	Digital
A1	A2	B1	Modbus	Analog Ex d/XP	Analog Ex d/XP	Modbus
A1	B1	X0	Modbus	Analog Ex i/IS	-	-
A1	B1	A1	Modbus	Analog Ex i/IS	-	Digital
A1	B1	A2	Modbus	Analog Ex i/IS	Digital	Digital
A1	B1	B1	Modbus	Modbus	Analog Ex i/IS	-
A1	B1	B2	Modbus	Modbus	Analog Ex i/IS	Digital
A1	B2	X0	Modbus	Analog Ex i/IS	Analog Ex i/IS	-
A1	B2	A1	Modbus	Analog Ex i/IS	Analog Ex i/IS	Digital
A1	B2	B1	Modbus	Analog Ex i/IS	Analog Ex i/IS	Modbus
A1	C2	X0	Modbus	Analog Ex i/IS	Analog Ex d/XP	-
A1	C2	A1	Modbus	Analog Ex i/IS	Analog Ex d/XP	Digital
A1	C2	B1	Modbus	Analog Ex i/IS	Analog Ex d/XP	Modbus

"Primary Output" (040) = "V1" (B1)

Ordering feature			Terminal area			
NRF81 - xxxx <u>XX</u> <u>XX</u> <u>XX</u> ... 040 050 060						
040 Primary Output	050 Secondary IO Analog	060 Secondary IO Digital Ex d/XP				
B1	X0	X0	V1	-	-	-
B1	X0	A1	V1	-	-	Digital
B1	X0	A2	V1	-	Digital	Digital
B1	X0	A3	V1	Digital	Digital	Digital
B1	X0	B1	V1	Modbus	-	-
B1	X0	B2	V1	Modbus	-	Digital
B1	X0	B3	V1	Modbus	Digital	Digital
B1	A1	X0	V1	Analog Ex d/XP	-	-
B1	A1	A1	V1	Analog Ex d/XP	-	Digital
B1	A1	A2	V1	Analog Ex d/XP	Digital	Digital
B1	A1	B1	V1	Modbus	Analog Ex d/XP	-
B1	A1	B2	V1	Modbus	Analog Ex d/XP	Digital
B1	A2	X0	V1	Analog Ex d/XP	Analog Ex d/XP	-
B1	A2	A1	V1	Analog Ex d/XP	Analog Ex d/XP	Digital
B1	A2	B1	V1	Analog Ex d/XP	Analog Ex d/XP	Modbus
B1	B1	X0	V1	Analog Ex i/IS	-	-
B1	B1	A1	V1	Analog Ex i/IS	-	Digital
B1	B1	A2	V1	Analog Ex i/IS	Digital	Digital
B1	B1	B1	V1	Modbus	Analog Ex i/IS	-
B1	B1	B2	V1	Modbus	Analog Ex i/IS	Digital
B1	B2	X0	V1	Analog Ex i/IS	Analog Ex i/IS	-
B1	B2	A1	V1	Analog Ex i/IS	Analog Ex i/IS	Digital
B1	B2	B1	V1	Analog Ex i/IS	Analog Ex i/IS	Modbus
B1	C2	X0	V1	Analog Ex i/IS	Analog Ex d/XP	-
B1	C2	A1	V1	Analog Ex i/IS	Analog Ex d/XP	Digital
B1	C2	B1	V1	Analog Ex i/IS	Analog Ex d/XP	Modbus

"Primary Output" (040) = "4-20mA HART Ex d" (E1)

Ordering feature			Terminal area			
NRF81 - xxxx <u>XX</u> <u>XX</u> <u>XX</u> ... 040 050 060						
040 Primary Output	050 Secondary IO Analog	060 Secondary IO Digital Ex d/XP				
E1	X0	X0	-	Analog Ex d/XP	-	-
E1	X0	A1	-	Analog Ex d/XP	-	Digital
E1	X0	A2	-	Analog Ex d/XP	Digital	Digital
E1	X0	A3	Digital	Analog Ex d/XP	Digital	Digital
E1	X0	B1	Modbus	Analog Ex d/XP	-	-
E1	X0	B2	Modbus	Analog Ex d/XP	-	Digital
E1	X0	B3	Modbus	Analog Ex d/XP	Digital	Digital
E1	A1	X0	-	Analog Ex d/XP	Analog Ex d/XP	-
E1	A1	A1	-	Analog Ex d/XP	Analog Ex d/XP	Digital
E1	A1	A2	Digital	Analog Ex d/XP	Analog Ex d/XP	Digital
E1	A1	B1	Modbus	Analog Ex d/XP	Analog Ex d/XP	-
E1	A1	B2	Modbus	Analog Ex d/XP	Analog Ex d/XP	Digital
E1	B1	X0	-	Analog Ex d/XP	Analog Ex i/IS	-
E1	B1	A1	-	Analog Ex d/XP	Analog Ex i/IS	Digital
E1	B1	A2	Digital	Analog Ex d/XP	Analog Ex i/IS	Digital
E1	B1	B1	Modbus	Analog Ex d/XP	Analog Ex i/IS	-
E1	B1	B2	Modbus	Analog Ex d/XP	Analog Ex i/IS	Digital

"Primary Output" (040) = "4-20mA HART Ex i" (H1)

Ordering feature			Terminal area			
NRF81 - xxxx <u>XX</u> <u>XX</u> <u>XX</u> ... 040 050 060						
040 Primary Output	050 Secondary IO Analog	060 Secondary IO Digital Ex d/XP				
H1	X0	X0	-	Analog Ex i/IS	-	-
H1	X0	A1	-	Analog Ex i/IS	-	Digital
H1	X0	A2	-	Analog Ex i/IS	Digital	Digital
H1	X0	A3	Digital	Analog Ex i/IS	Digital	Digital
H1	X0	B1	Modbus	Analog Ex i/IS	-	-
H1	X0	B2	Modbus	Analog Ex i/IS	-	Digital
H1	X0	B3	Modbus	Analog Ex i/IS	Digital	Digital
H1	A1	X0	-	Analog Ex i/IS	Analog Ex d/XP	-
H1	A1	A1	-	Analog Ex i/IS	Analog Ex d/XP	Digital
H1	A1	A2	Digital	Analog Ex i/IS	Analog Ex d/XP	Digital
H1	A1	B1	Modbus	Analog Ex i/IS	Analog Ex d/XP	-
H1	A1	B2	Modbus	Analog Ex i/IS	Analog Ex d/XP	Digital
H1	B1	X0	-	Analog Ex i/IS	Analog Ex i/IS	-
H1	B1	A1	-	Analog Ex i/IS	Analog Ex i/IS	Digital
H1	B1	A2	Digital	Analog Ex i/IS	Analog Ex i/IS	Digital
H1	B1	B1	Modbus	Analog Ex i/IS	Analog Ex i/IS	-
H1	B1	B2	Modbus	Analog Ex i/IS	Analog Ex i/IS	Digital

6.1.5 Terminals of the "Modbus" or "V1" module

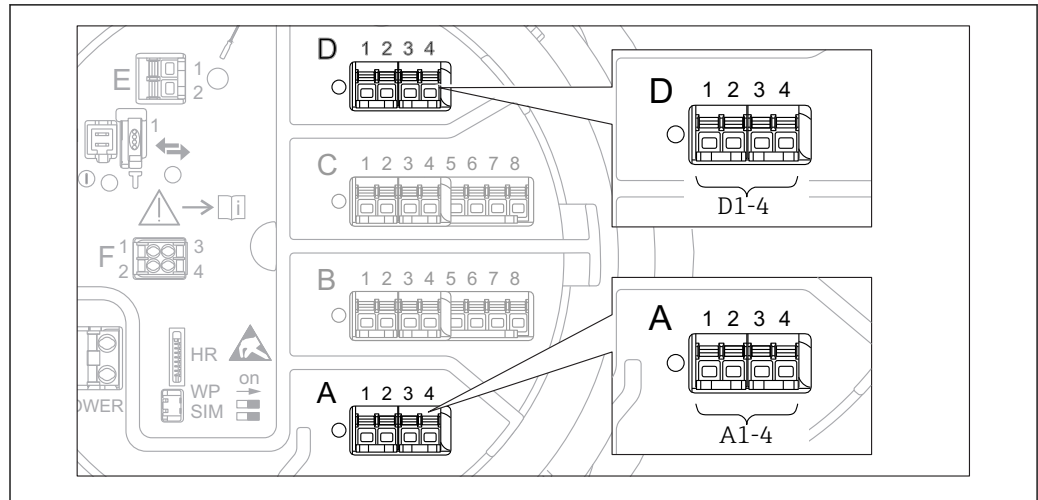

8 Designation of the "Modbus" or "V1" modules (examples); depending on the device version these modules may also be in slot B or C.

Depending on the device version, the "Modbus" and/or "V1" module may be in different slots of the terminal compartment. In the operating menu the "Modbus" and "V1" interfaces are designated by the respective slot and the terminals within this slot: **A1-4, B1-4, C1-4, D1-4.**

Terminals of the "Modbus" module

Terminal ¹⁾	Name	Description
X1	S	Cable shielding connected via a capacitor to EARTH
X2	0V	Common reference
X3	B-	Non-inverting signal line
X4	A+	Inverting signal line
Designation of the module in the operating menu: Modbus X1-4 ; (X = A, B, C or D)		

1) In this column, "X" stands for one of the slots "A", "B", "C", or "D".

Terminals of the "V1" module

Terminal ¹⁾	Name	Description
X1	S	Cable shielding connected via capacitor to EARTH
X2		not connected
X3	B-	Protocol loop signal -
X4	A+	Protocol loop signal +
Designation of the module in the operating menu: V1 X1-4 ; (X = A, B, C or D)		

1) In this column, "X" stands for one of the slots "A", "B", "C", or "D".

6.1.6 Terminals of the "Analog I/O" module (Ex d /XP or Ex i/IS)

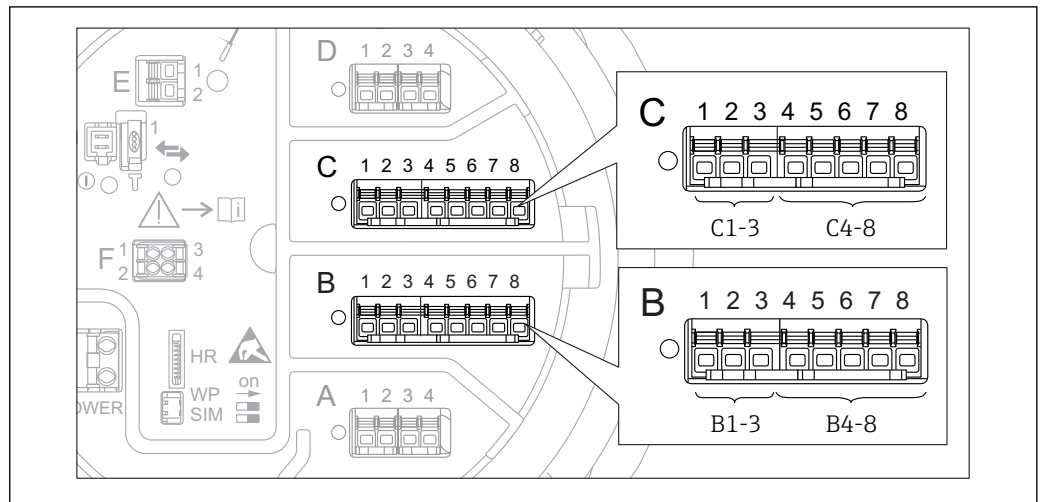

A0031168

Terminals	Function	Connection diagrams	Designation in the operating menu
B1-3	Analog input or output (configurable)	<ul style="list-style-type: none"> ■ Passive usage: → ☰ 28 ■ Active usage: → ☰ 30 	Analog I/O B1-3 (→ ☰ 138)
C1-3			Analog I/O C1-3 (→ ☰ 138)
B4-8	Analog input	<ul style="list-style-type: none"> ■ RTD: → ☰ 31 ■ FMR5xx: → ☰ 32 	Analog IP B4-8 (→ ☰ 132)
C4-8			Analog IP C4-8 (→ ☰ 132)

6.1.7 Connection of the "Analog I/O" module for passive usage

- i** In the passive usage the supply voltage for the communication line must be supplied by an external source.
- The wiring must be in accordance with the intended operating mode of the Analog I/O module; see the drawings below.

"Operating mode" = "4..20mA output" or "HART slave +4..20mA output"

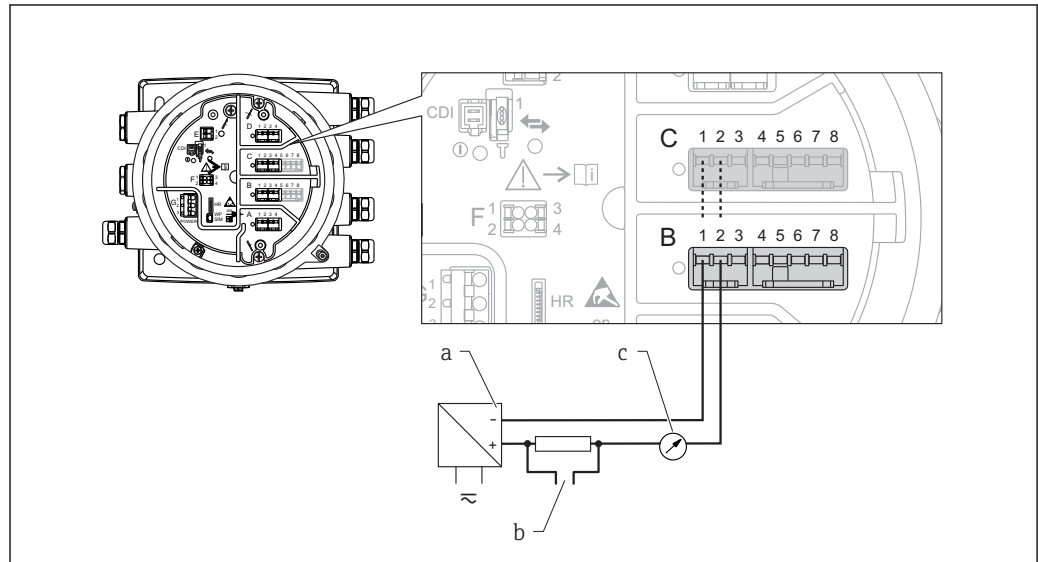

A0027931

9 Passive usage of the Analog I/O module in the output mode

- a Power supply
- b HART signal output
- c Analog signal evaluation

"Operating mode" = "4..20mA input" or "HART master+4..20mA input"

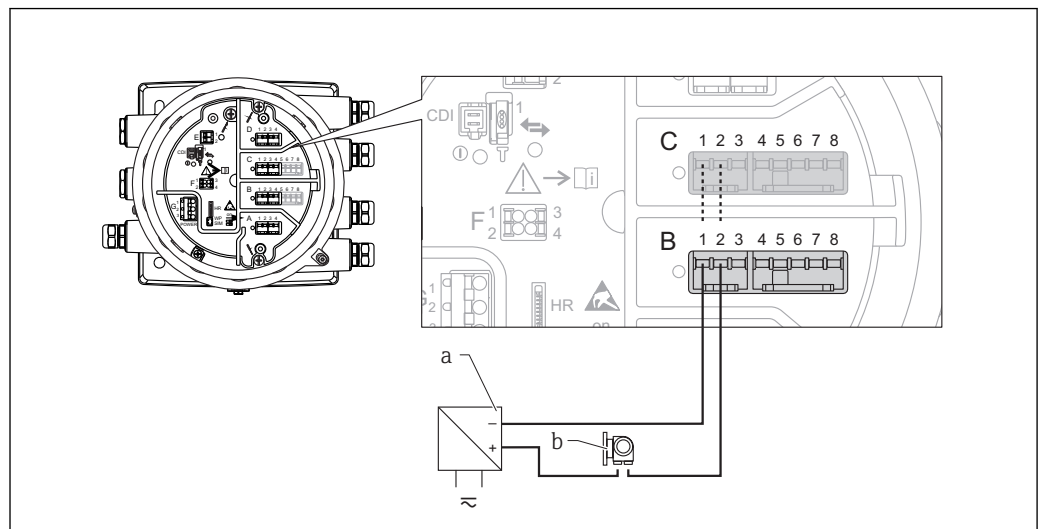

A0027933

10 Passive usage of the Analog I/O module in the input mode

- a Power supply
- b External device with 4...20mA and/or HART signal output

"Operating mode" = "HART master"

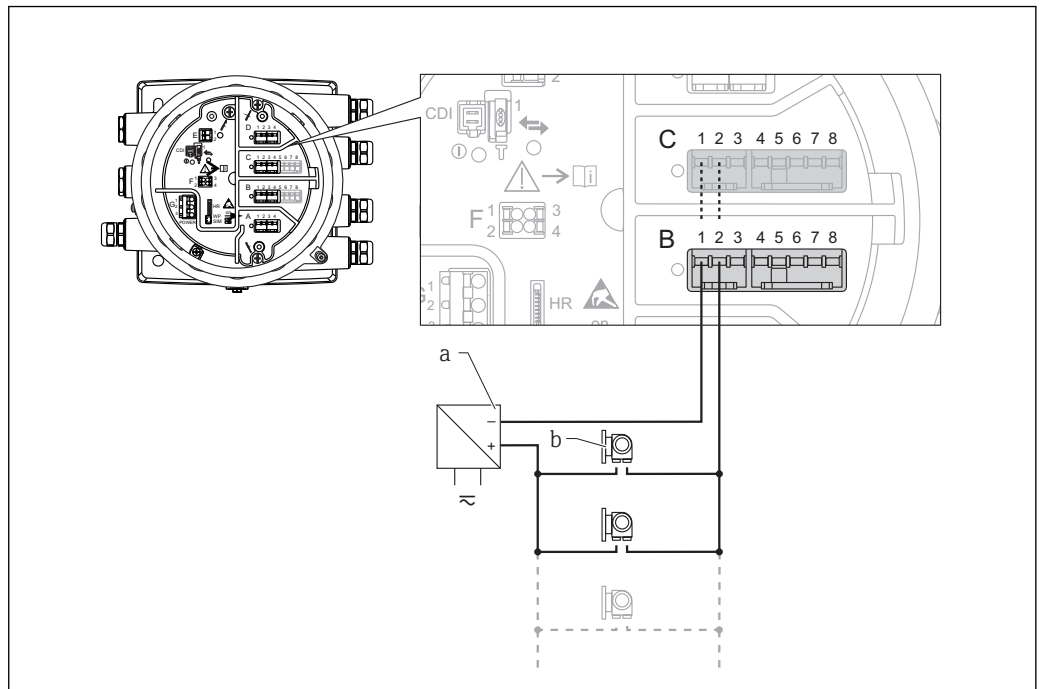

A0027934

11 Passive usage of the Analog I/O module in the HART master mode

- a Power supply
- b Up to 6 external devices with HART signal output

6.1.8 Connection of the "Analog I/O" module for active usage

- i** In the active usage the supply voltage for the communication line is supplied by the device itself. There is no need of an external power supply.
- The wiring must be in accordance with the intended operating mode of the Analog I/O module; see the drawings below.
- i** Maximum current consumption of the connected HART devices: 24 mA (i.e. 4 mA per device if 6 devices are connected).
- Output voltage of the Ex-d module: 17.0 V@4 mA to 10.5 V@22 mA
- Output voltage of the Ex-ia module: 18.5 V@4 mA to 12.5 V@22 mA

"Operating mode" = "4..20mA output" or "HART slave +4..20mA output"

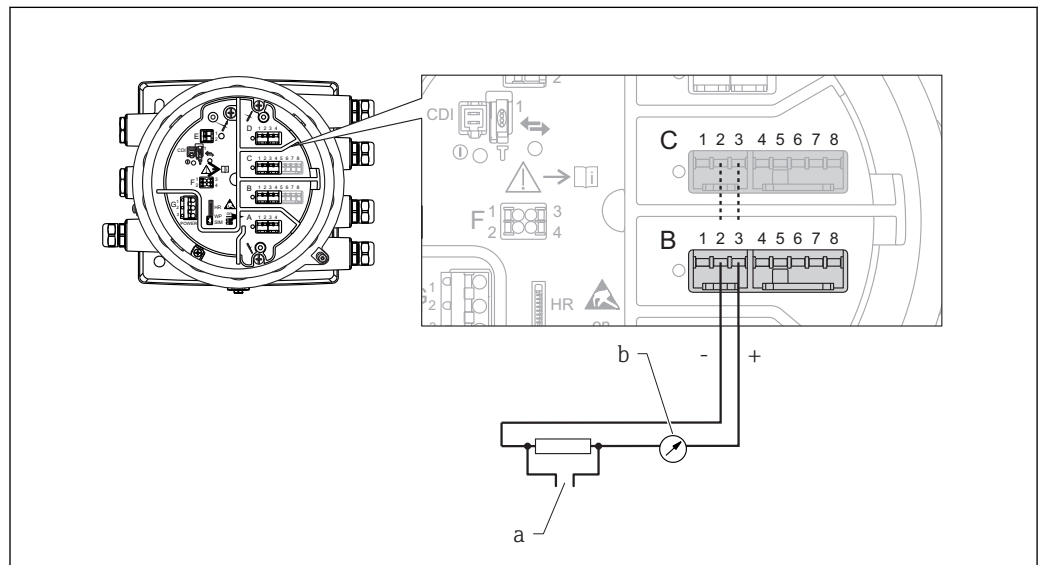

A0027932

12 Active usage of the Analog I/O module in the output mode

- a HART signal output
- b Analog signal evaluation

"Operating mode" = "4..20mA input" or "HART master+4..20mA input"

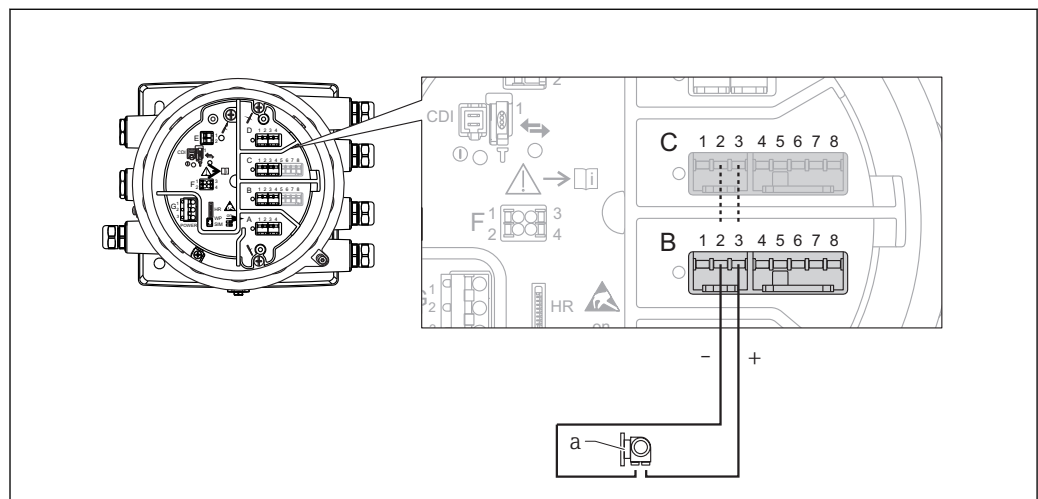

A0027935

13 Active usage of the Analog I/O module in the input mode

- a External device with 4...20mA and/or HART signal output

"Operating mode" = "HART master"

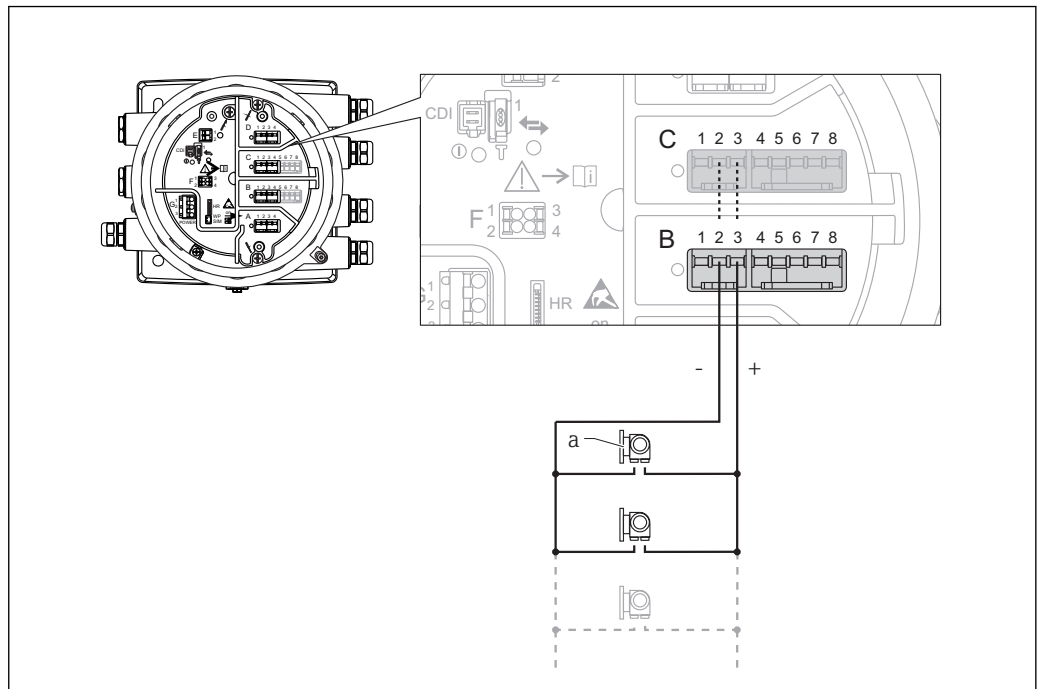

A0027936

14 Active usage of the Analog I/O module in the HART master mode

a Up to 6 external devices with HART signal output

i The maximum current consumption for the connected HART devices is 24 mA (i.e. 4 mA per device if 6 devices are connected).

6.1.9 Connection of a RTD

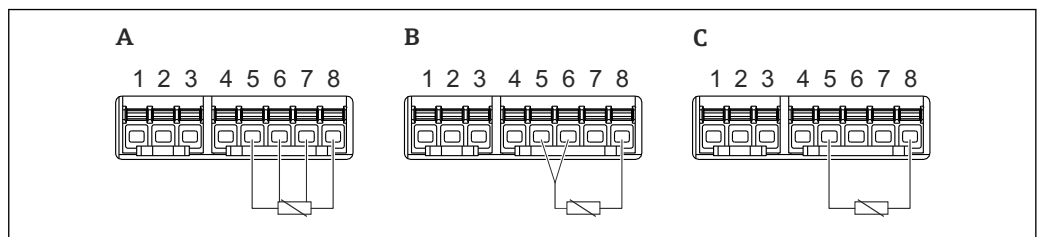

A0026371

A 4-wire RTD connection

B 3-wire RTD connection

C 2-wire RTD connection

6.1.10 Connection of a Micropilot S FMR5xx

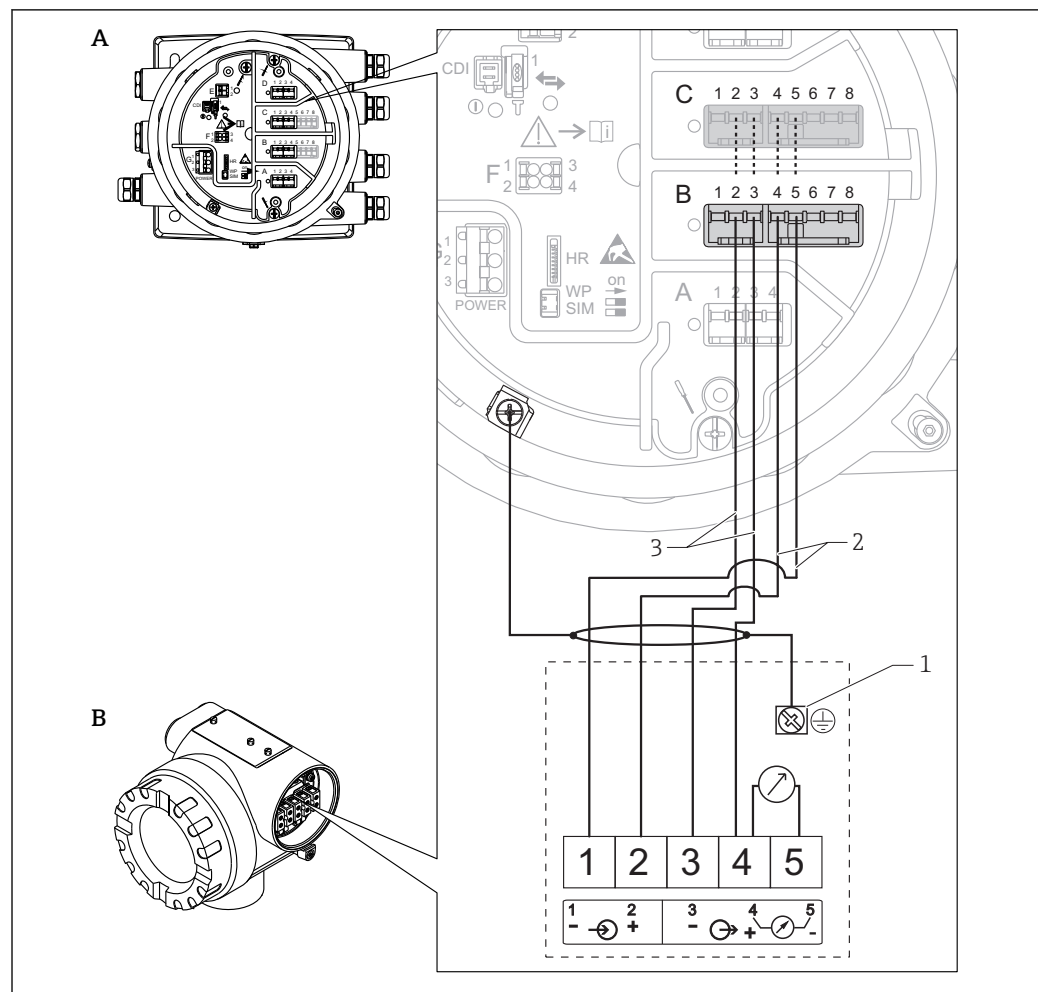

A0027717

15 Connection of a Micropilot S FMR5xx to the Analog input module of a Tankside Monitor NRF81

- A Tankside Monitor NRF81
- B Micropilot S FMR5xx
- 1 Grounding
- 2 Power supply (from NRF81 to FMR5xx)
- 3 4-20mA/HART signal (from FMR5xx to NRF81)

i If connected in this way, the Micropilot S FMR5xx gets its supply voltage from the Tankside Monitor NRF81.

6.1.11 Terminals of the "Digital I/O" module

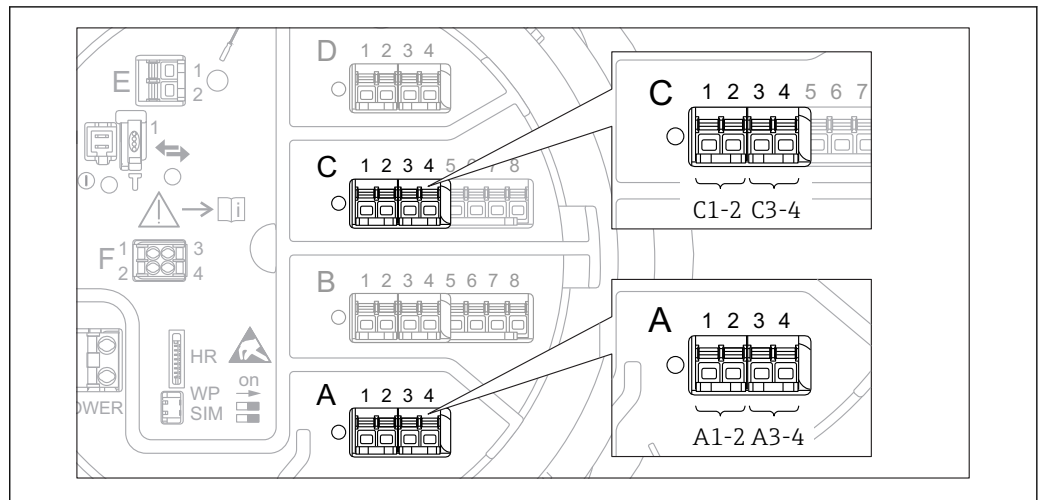

16 Designation of the digital inputs or outputs (examples)

- Each Digital IO Module provides two digital inputs or outputs.
- In the operating menu each input or output is designated by the respective slot and two terminals within this slot. **A1-2**, for example, denotes terminals 1 and 2 of slot **A**. The same is valid for slots **B**, **C** and **D** if they contain a Digital IO module.
- For each of these pairs of terminals, one of the following operating modes can be selected in the operating menu:
 - Disable
 - Passive Output
 - Passive Input
 - Active Input

6.2 Connecting requirements

6.2.1 Cable specification

Terminals

Terminal	Wire cross section
Signal and power supply <ul style="list-style-type: none"> ▪ Spring terminals (NRF81-xx1...) ▪ Screw terminals (NRF81-xx2...) 	0.2 to 2.5 mm ² (24 to 13 AWG)
Ground terminal in the terminal compartment	max. 2.5 mm ² (13 AWG)
Ground terminal at the housing	max. 4 mm ² (11 AWG)

Power supply line

Standard device cable is sufficient for the power line.

HART communication line

- Standard device cable is sufficient if only the analog signal is used.
- Shielded cable is recommended if using the HART protocol. Observe the grounding concept of the plant.

Modbus communication line

- Observe the cable conditions from the TIA-485-A, Telecommunications Industry Association.
- Additional conditions: Use shielded cable.

V1 communication line

- Two wire (twisted pair) screened or un-screened cable
- Resistance in one cable: $\leq 120 \Omega$
- Capacitance between lines: $\leq 0.3 \mu\text{F}$

6.3 Ensuring the degree of protection

To guarantee the specified degree of protection, carry out the following steps after the electrical connection:

1. Check that the housing seals are clean and fitted correctly. Dry, clean or replace the seals if necessary.
2. Tighten all housing screws and screw covers.
3. Firmly tighten the cable glands.
4. To ensure that moisture does not enter the cable entry, route the cable so that it loops down before the cable entry ("water trap").

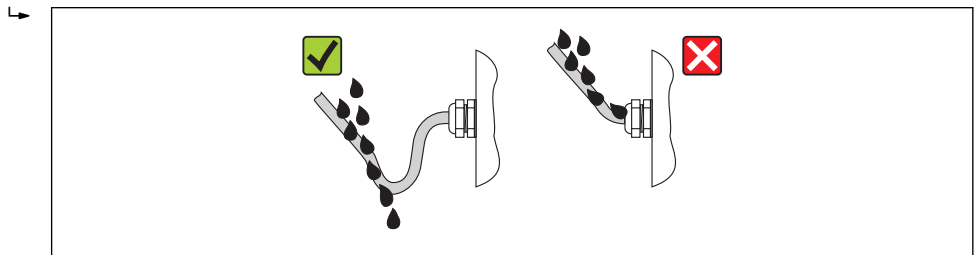

A0013960

5. Insert blind plugs appropriate for the safety rating of the device (e.g. Ex d/XP).





6.4 Post-connection check

<input type="radio"/>	Are cables or the device undamaged (visual inspection)?
<input type="radio"/>	Do the cables comply with the requirements?
<input type="radio"/>	Do the cables have adequate strain relief?
<input type="radio"/>	Are all cable glands installed, firmly tightened and correctly sealed?
<input type="radio"/>	Does the supply voltage match the specifications on the transmitter nameplate?
<input type="radio"/>	Is the terminal assignment correct → 18?
<input type="radio"/>	If required: Is the protective earth connected correctly ?
<input type="radio"/>	If supply voltage is present: Is the device ready for operation and do values appear on the display module?
<input type="radio"/>	Are all housing covers installed and firmly tightened?
<input type="radio"/>	Is the securing clamp tightened correctly?

7 Operability

7.1 Overview of the operation options

The device is operated via an operating menu →  37. This menu can be accessed by the following interfaces:

- The display and operating module at the device or the remote display and operating module DKX001 (→  38).
- FieldCare connected through the service interface in the terminal compartment of the device (→  50).
- FieldCare connected through Tankvision Tank Scanner NXA820 (remote operation; →  51).
- FieldCare connected through Commubox FXA195 (→  103) to a HART interface of the device.

7.2 Structure and function of the operating menu

Menu	Submenu / parameter	Meaning
Operation	Level	Shows the measured and calculated level values.
	Temperature	Shows the measured and calculated temperature values.
	Density	Shows the measured and calculated density values.
	Pressure	Shows the measured and calculated pressure values.
	GP values	Shows the general purpose values.
Setup	Parameters 1 to N	Standard commissioning parameters
	Advanced setup	Contains further parameters and submenus: <ul style="list-style-type: none"> ▪ to adapt the device to special measuring conditions. ▪ to process the measured value. ▪ to configure the signal output.
Diagnostics	Diagnostic parameters	Indicates: <ul style="list-style-type: none"> ▪ The latest diagnostic messages and their timestamps. ▪ The operating time (overall time and time since last restart). ▪ The time according to the real-time clock.
	Diagnostic list	Contains up to 5 currently active error messages.
	Device information	Contains information needed to identify the device.
	Simulation	Used to simulate measured values or output values.
Expert ¹⁾ Contains all parameters of the device (including those which are already contained in one of the other menus). This menu is organized according to the function blocks of the device. The parameter of the Expert menu are described in: GP01083G (NRF81)	System	Contains all general device parameters which do not affect the measurement or the communication interface.
	Input/output	Contains submenus to configure the analog and discrete I/O modules and connected HART devices.
	Communication	Contains all parameters needed to configure the digital communication interface.
	Application	Contains submenus to configure <ul style="list-style-type: none"> ▪ the tank gauging application ▪ the tank calculations ▪ the alarms.
	Tank values	Shows measured and calculated tank values
	Diagnostics	Contains all parameters needed to detect and analyze operational errors.

1) On entering the "Expert" menu, an access code is always requested. If a customer specific access code has not been defined, "0000" has to be entered.

7.3 Access to the operating menu via the local or remote display and operating module.

- i
 - Operating via the remote display and operating module DKX001 (→  19) or the local display and operating module at the device are equivalent.
 - The measured value is indicated on the DKX001 and on the local display and operating module simultaneously.
 - The operating menu cannot be accessed on both modules at the same time. If the operating menu is entered in one of these modules, the other module is automatically locked. This locking remains active until the menu is closed in the first module (back to measured value display).

7.3.1 Display and operating elements

The device has an illuminated **liquid crystal display (LCD)** that shows measured and calculated values as well as the device status in the standard view. Other views are used to navigate through the operating menu and to set parameter values.

The device is operated by **three optical keys**, namely "-", "+" and "E". They are actuated when the appropriate field on the protective glass of the front is touched with the finger ("touch control").

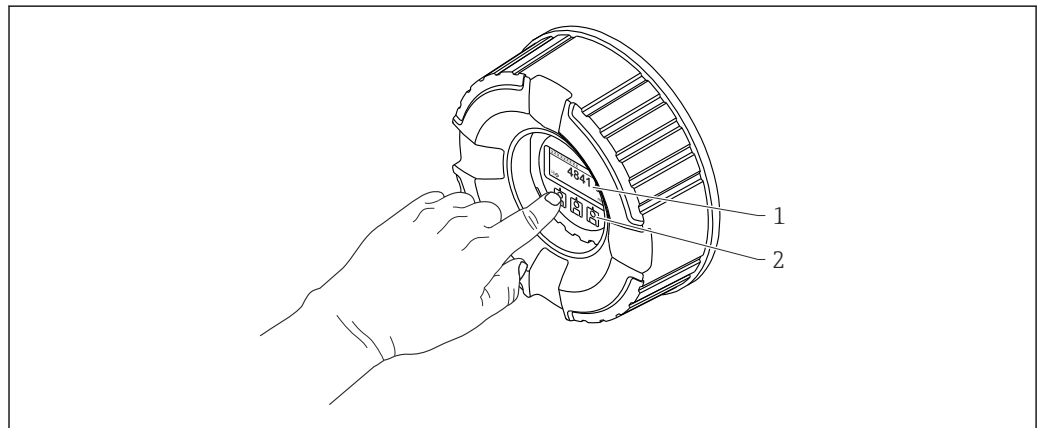

A0028345

 17 Display and operating elements

- 1 Liquid crystal display (LCD)
- 2 Optical keys; can be operated through the cover glass.

7.3.2 Standard view (measured value display)

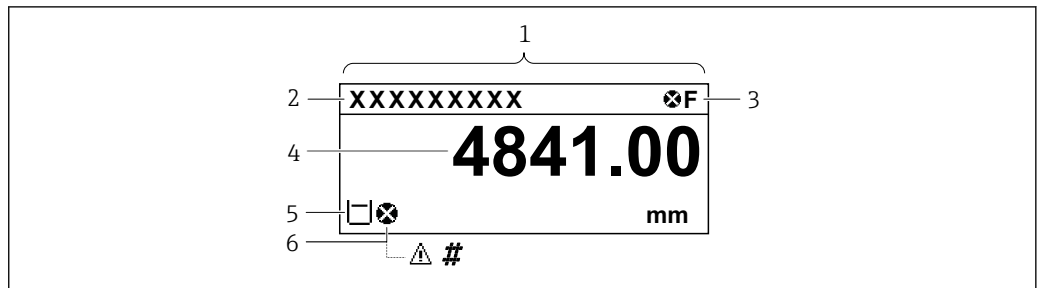

A0028317

18 Typical appearance of the standard view (measured value display)

- 1 Display module
- 2 Device tag
- 3 Status area
- 4 Display area for measured values
- 5 Display area for measured value and status symbols
- 6 Measured value status symbol

Status symbols

Symbol	Meaning
F A0013956	"Failure" A device error is present. The measured value is no longer valid.
C A0013959	"Function check" The device is in service mode (e.g. during a simulation).
S A0013958	"Out of specification" The device is operated: <ul style="list-style-type: none"> ▪ Outside of its technical specifications (e.g. during startup or a cleaning) ▪ Outside of the configuration carried out by the user (e.g. level outside configured span)
M A0013957	"Maintenance required" Maintenance is required. The measured value is still valid.

Measured value status symbols

Symbol	Meaning
 A0012102	Status "Alarm" The measurement is interrupted. The output assumes the defined alarm value. A diagnostic message is generated.
 A0012103	Status "Warning" The device continues measuring. A diagnostic message is generated.
 A0031169	Calibration to regulatory standards disturbed Is displayed in the following situations: <ul style="list-style-type: none"> ▪ The write protection switch is OFF. → 48 ▪ The write protection switch is ON but the level value can currently not be guaranteed.

Locking state symbols

Symbol	Meaning
 A0011978	Display parameter Marks display-only parameters which cannot be edited.
 A0011979	Device locked <ul style="list-style-type: none"> ▪ In front of a parameter name: The device is locked via software and/or hardware. ▪ In the header of the measured value screen: The device is locked via hardware.

Meaning of the keys in the standard view

Key	Meaning
 <p>A0028326</p>	<p>Enter key</p> <ul style="list-style-type: none"> ■ Pressing the key briefly opens the operating menu. ■ Pressing the key for 2 s opens the context menu: <ul style="list-style-type: none"> - Level (visible if the keylock is inactive): Shows the measured levels. - Keylock on (visible if the keylock is inactive): Activates the keylock. - Keylock off (visible if the keylock is active): Deactivates the keylock.

7.3.3 Navigation view

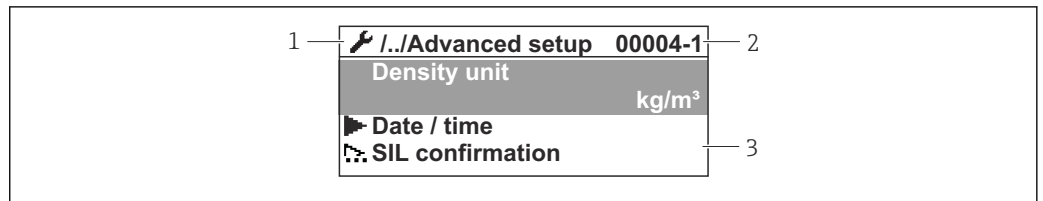







A0028348-EN





19 Navigation view

- 1 Current submenu or wizard
- 2 Quick access code
- 3 Display area for navigation

Navigation symbols

Symbol	Meaning
 A0011975	Operation Is displayed: <ul style="list-style-type: none"> ▪ in the main menu next to the selection Operation ▪ in the header, if you are in the Operation menu.
 A0011974	Setup Is displayed: <ul style="list-style-type: none"> ▪ in the main menu next to the selection Setup ▪ in the header, if you are in the Setup menu
 A0011976	Expert Is displayed: <ul style="list-style-type: none"> ▪ in the main menu next to the selection Expert ▪ in the header, if you are in the Expert menu
 A0011977	Diagnostics Is displayed: <ul style="list-style-type: none"> ▪ in the main menu next to the selection Diagnostics ▪ in the header, if you are in the Diagnostics menu
 A0013967	Submenu
 A0013968	Wizard
 A0013963	Parameter locked When displayed in front of a parameter name, indicates that the parameter is locked.

Meaning of the keys in the navigation view

Key	Meaning
 <p style="text-align: center; font-size: small;">A0028324</p>	<p>Minus key Moves the selection bar upwards in a picklist.</p>
 <p style="text-align: center; font-size: small;">A0028325</p>	<p>Plus key Moves the selection bar downwards in a picklist.</p>
 <p style="text-align: center; font-size: small;">A0028326</p>	<p>Enter key</p> <ul style="list-style-type: none"> ■ Pressing the key briefly opens the selected menu, submenu or parameter. ■ For parameters: Pressing the key for 2 s opens the help text for the function of the parameter (if present).
 <p style="text-align: center; font-size: small;">A0028327</p>	<p>Escape key combination (press keys simultaneously)</p> <ul style="list-style-type: none"> ■ Pressing the keys briefly <ul style="list-style-type: none"> - Exits the current menu level and takes you to the next higher level. - If help text is open, closes the help text of the parameter. ■ Pressing the keys for 2 s returns you to the measured value display ("standard view").

7.3.4 Wizard view

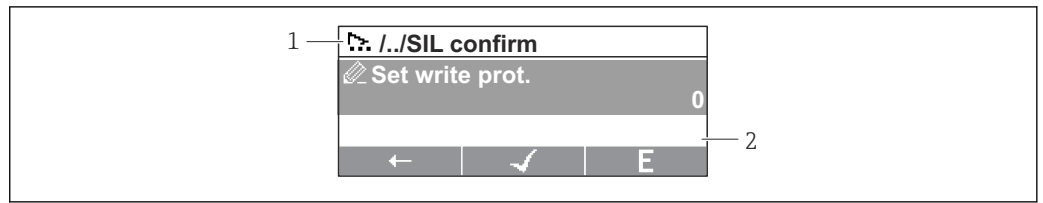





A0028351-EN

20 Wizard view on the display module

- 1 Current wizard
- 2 Display area for navigation

Wizard navigation symbols

Symbol	Meaning
 A0013972	Parameters within a wizard
 A0013978	Switches to the previous parameter.
 A0013976	Confirms the parameter value and switches to the next parameter.
 A0013977	Opens the editing view of the parameter.

 In the wizard view the meaning of the keys is indicated by the navigation symbol directly above the respective key (softkey functionality).



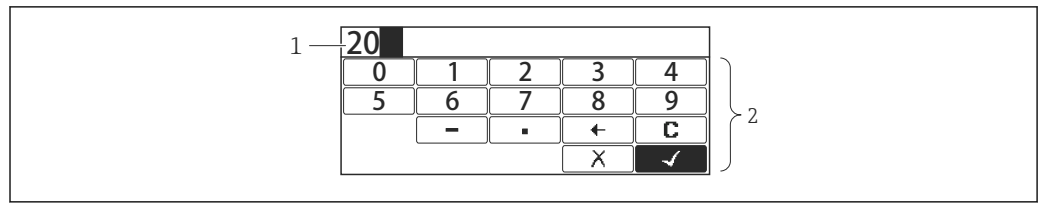



7.3.5 Numeric editor







A0028341

21 Numeric editor on the display module

- 1 Display area of the entered value
- 2 Input mask

Symbol	Meaning
 <p>A0013998</p>	Selection of numbers from 0 to 9.
 <p>A0016619</p>	Inserts decimal separator at the input position.
 <p>A0016620</p>	Inserts minus sign at the input position.
 <p>A0013985</p>	Confirms selection.
 <p>A0016621</p>	Moves the input position one position to the left.
 <p>A0013986</p>	Exits the input without applying the changes.
 <p>A0014040</p>	Clears all entered characters.

Meaning of the keys in the numeric editor

Key	Meaning
 <p>A0028324</p>	Minus key In the input mask, moves the selection bar to the left (backwards).
 <p>A0028325</p>	Plus key In the input mask, moves the selection bar to the right (forwards).
 <p>A0028326</p>	Enter key <ul style="list-style-type: none"> ■ Pressing the key briefly adds the selected number to the current decimal place or carries out the selected action. ■ Pressing the key for 2 s confirms the edited parameter value.
 <p>A0028327</p>	Escape key combination (press keys simultaneously) Closes the text or numeric editor without applying changes.

7.3.6 Text editor

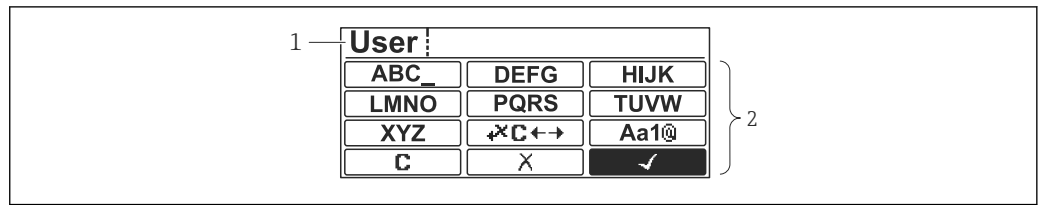

A0028342

22 Text editor on the display module

- 1 Display area of the entered text
- 2 Input mask





Text editor symbols

Symbol	Meaning
 <small>A0013997</small>	Selection of letters from A to Z
 <small>A0013981</small>	Toggle <ul style="list-style-type: none"> ▪ Between upper-case and lower-case letters ▪ For entering numbers ▪ For entering special characters
 <small>A0013985</small>	Confirms selection.
 <small>A0013987</small>	Switches to the selection of the correction tools.
 <small>A0013986</small>	Exits the input without applying the changes.
 <small>A0014040</small>	Clears all entered characters.

Correction symbols under

 <small>A0013989</small>	Clears all entered characters.
 <small>A0013991</small>	Moves the input position one position to the right.
 <small>A0013990</small>	Moves the input position one position to the left.
 <small>A0013988</small>	Deletes one character immediately to the left of the input position.

Meaning of the keys in the text editor

Key	Meaning
 A0028324	Minus key In the input mask, moves the selection bar to the left (backwards).
 A0028325	Plus key In the input mask, moves the selection bar to the right (forwards).
 A0028326	Enter key <ul style="list-style-type: none"> ▪ Pressing the key briefly <ul style="list-style-type: none"> - Opens the selected group. - Carries out the selected action. ▪ Pressing the key for 2 s confirms the edited parameter value.
 A0028327	Escape key combination (press keys simultaneously) Closes the text or numeric editor without applying changes.

7.3.7 Keypad lock**Automatic keypad lock**

Operation via the local display is automatically locked:

- after a start-up or restart of the device.
- if the device has not been operated via the display for > 1 minute.

 When attempting to access the operating menu while the keylock is enabled, the **Keylock on** message appears.

Disabling the keypad lock

1. The keylock is enabled.
 Press  for at least 2 seconds.
 - ↳ A context menu appears.
2. Select **Keylock off** from the context menu.
 - ↳ The keylock is disabled.

Manual activation of the keypad lock

After commissioning of the device the keypad lock can be activated manually.

1. The device is in the measured value display.
 Press  for at least 2 seconds.
 - ↳ A context menu appears.
2. Select **Keylock on** from the context menu.
 - ↳ The keylock is enabled.

7.3.8 Access code and user roles

Meaning of the access code

An access code can be defined in order to distinguish between the following user roles:

User role	Definition
Maintenance	<ul style="list-style-type: none"> ▪ Knows the access code. ▪ Has write access to all parameters (except service parameters).
Operator	<ul style="list-style-type: none"> ▪ Doesn't know the access code. ▪ Has write access to only a few parameters.



- 
 - The description of parameters states which role is needed at least for read and write access to each parameter.
 - The current user role is indicated by the **Access status display** parameter.
 - If the access code is "0000", every user is in the **Maintenance** role. This is the default setting on delivery of the device.

Defining an access code

1. Navigate to: Setup → Advanced setup → Administration → Define access code → Define access code
2. Enter the intended access code (max. 4 digits).
3. Repeat the same code in the **Confirm access code** parameter.
 - ↳ The user is in the **Operator** role. The -symbol appears in front of all write-protected parameters.

Switching to the "Maintenance" role

If the -symbol appears on the local display in front of a parameter, the parameter is write-protected because the user is in the **Operator** role. To switch to the **Maintenance** role, proceed as follows:

1. Press .
 - ↳ The input prompt for the access code appears.
2. Enter the access code.
 - ↳ The user is in the **Maintenance** role. The -symbol in front of the parameters disappears; all previously write-protected parameters are now re-enabled.

Switching back to the "Operator" role automatically

The user automatically switches back to the **Operator** role:

- if no key is pressed for 10 minutes in the navigation and editing mode.
- 60 s after going back from the navigation and editing mode to the standard view (measured value display).

7.3.9 Write protection switch

The operating menu can be locked by a hardware switch in the connection compartment. In this locking state W&M related parameters are read only.

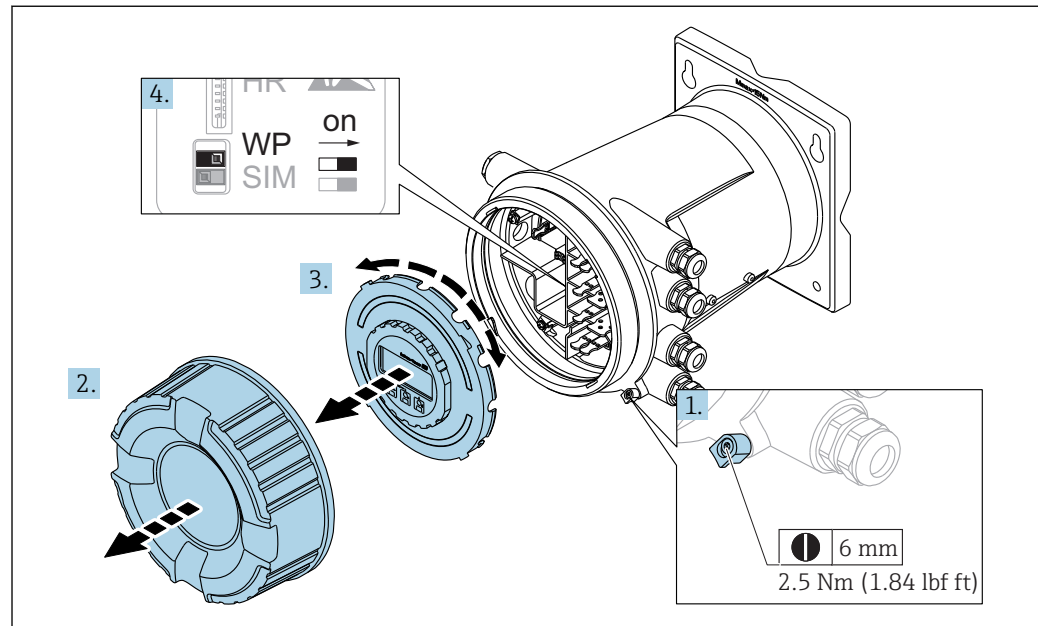

A0028364

1. Loosen the securing clamp.
2. Unscrew the housing cover.
3. Pull out the display module with a gentle rotation movement.
4. Using a flat blade screwdriver or a similar tool, set the write protection switch (**WP**) into the desired position. **ON**: operating menu is locked; **OFF**: operating menu is unlocked.
5. Put the display module onto the connection compartment, screw the cover closed and tighten the securing clamp.

i To avoid access to the write protection switch, the cover of the connection compartment can be secured by a lead seal.

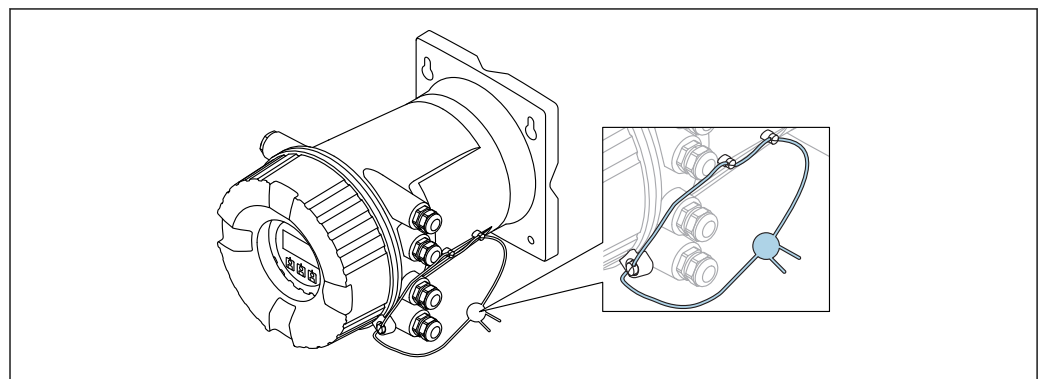

A0033364

i The display module can be attached to the edge of the electronics compartment. This makes it easier to access the lock switch.

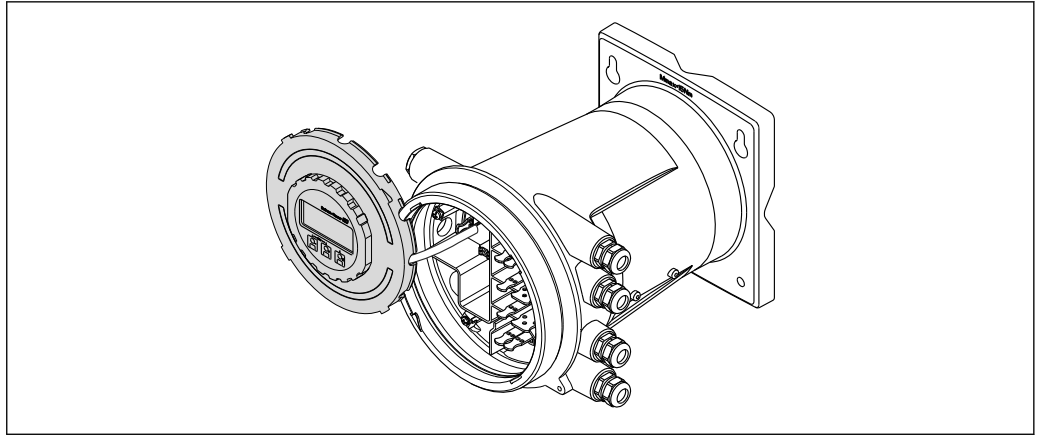

A0028382

Indication of the locking state

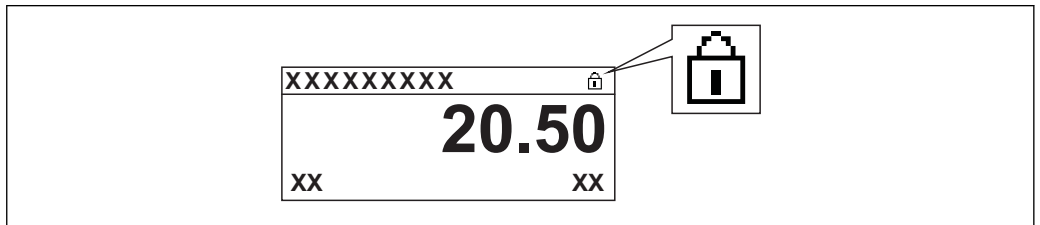

A0015870

🔒 23 Write protection symbol in the header of the display

Write protection via locking switch is indicated as follows:

- **Locking status** (→ 📄 124) = **Hardware locked**
- 🔒 appears in the header of the display.

7.4 Access to the operating menu via the service interface and FieldCare

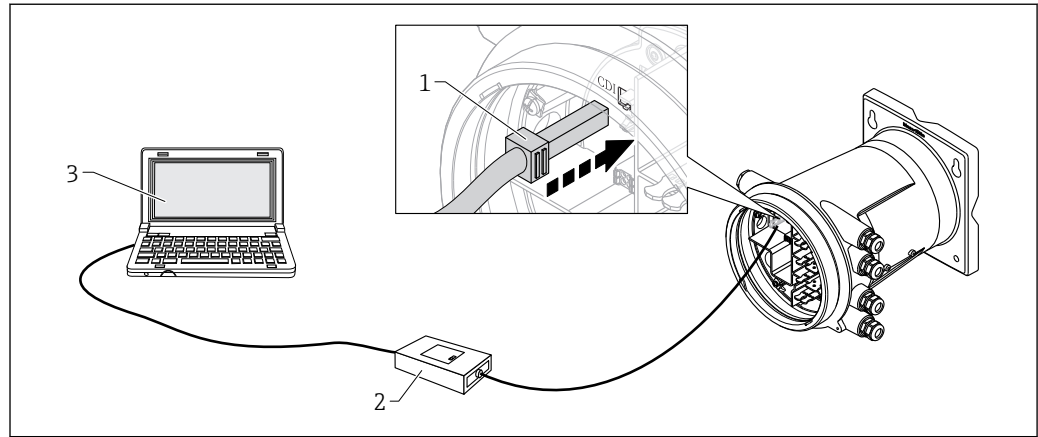

24 Operation via service interface

- 1 Service interface (CDI = Endress+Hauser Common Data Interface)
- 2 Commubox FXA291
- 3 Computer with "FieldCare" operating tool and "CDI Communication FXA291" COM DTM

i The "Save/Restore" function

After a device configuration has been saved to a computer and restored to the device using the **Save/Restore** function of FieldCare, the device must be restarted by the following setting:

Setup → **Advanced setup** → **Administration** → **Device reset** = **Restart device**.

This ensures correct operation of the device after the restore.

7.5 Access to the operating menu via Tankvision Tank Scanner NXA820 and FieldCare

7.5.1 Wiring scheme

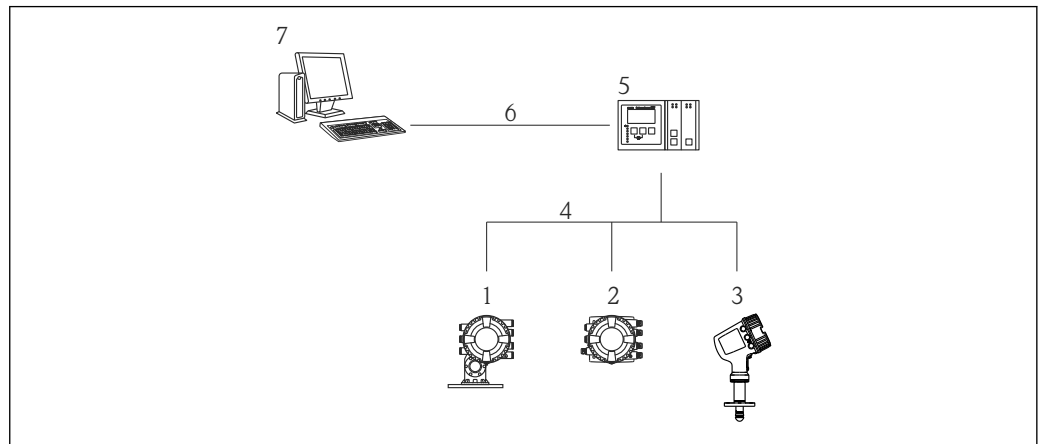

A0025621

25 Connection of Tank Gauging devices to FieldCare via the Tankvision Tank Scanner NXA820

- 1 Proservo NMS8x
- 2 Tankside Monitor NRF81
- 3 Micropilot NMR8x
- 4 Field protocol (e.g. Modbus, V1)
- 5 Tankvision Tank Scanner NXA820
- 6 Ethernet
- 7 Computer with FieldCare installed

7.5.2 Establishing the connection between FieldCare and the device

1. Make sure the **HART CommDTM NXA** is installed and update the DTM catalogue if required.
2. Create a new project in FieldCare.
- 3.

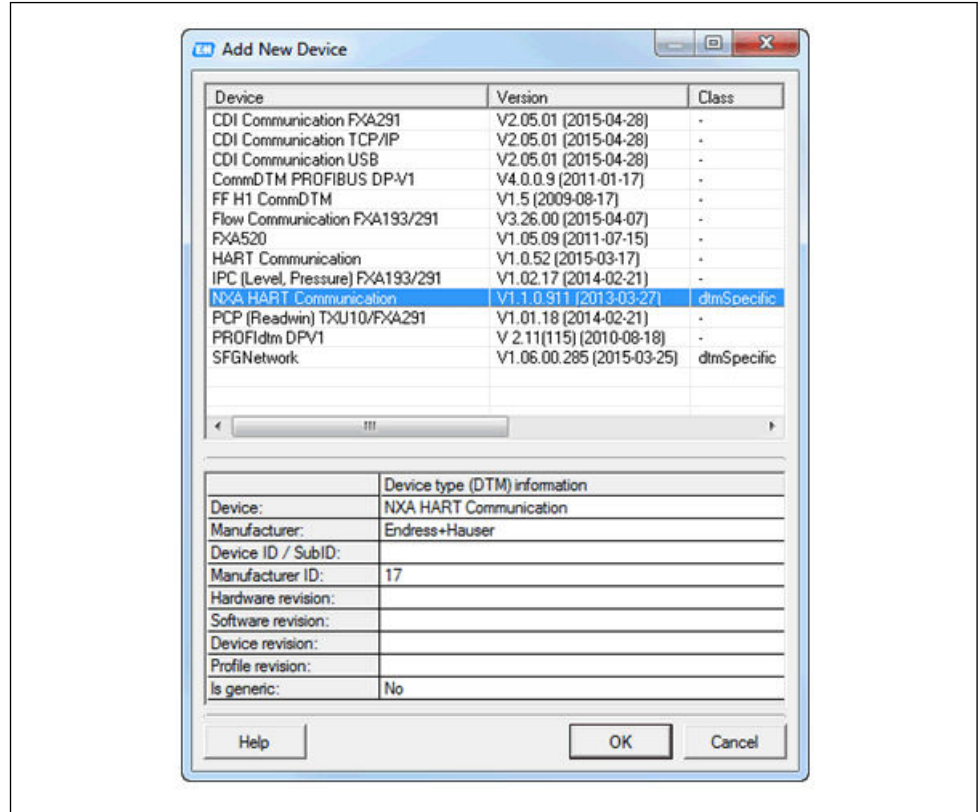

A0028515

Add a new device: **NXA HART Communication**

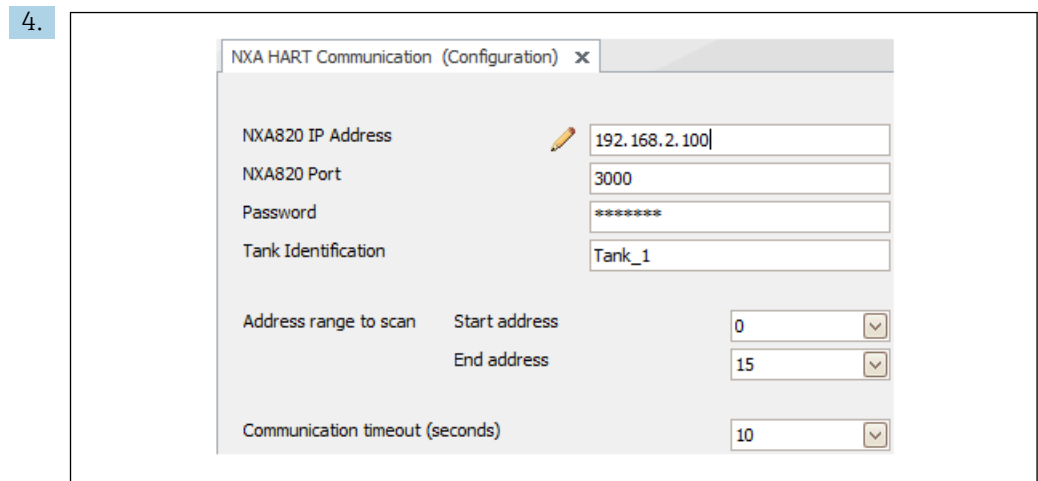

A0028516

Open the configuration of the DTM and enter the required data (IP address of the NXA820; "Password" = "hart"; "Tank identification" only with NXA V1.05 or higher)

5.

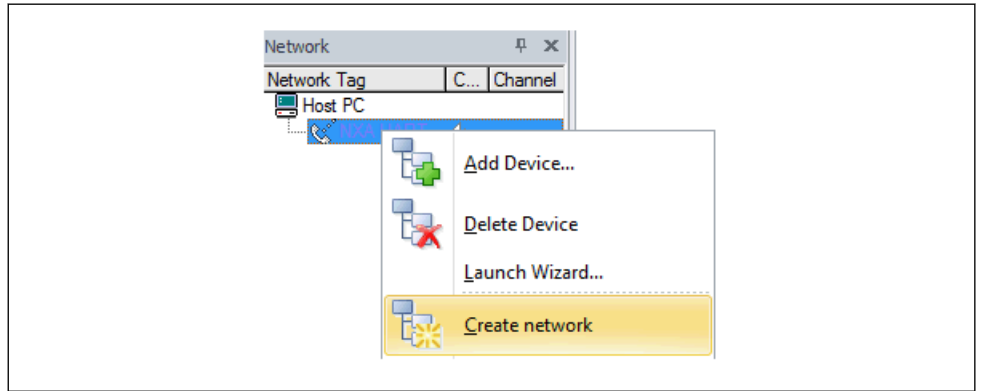

A0028517

Select **Create network** from the context menu.

↳ The device is detected and the DTM is assigned.

6.

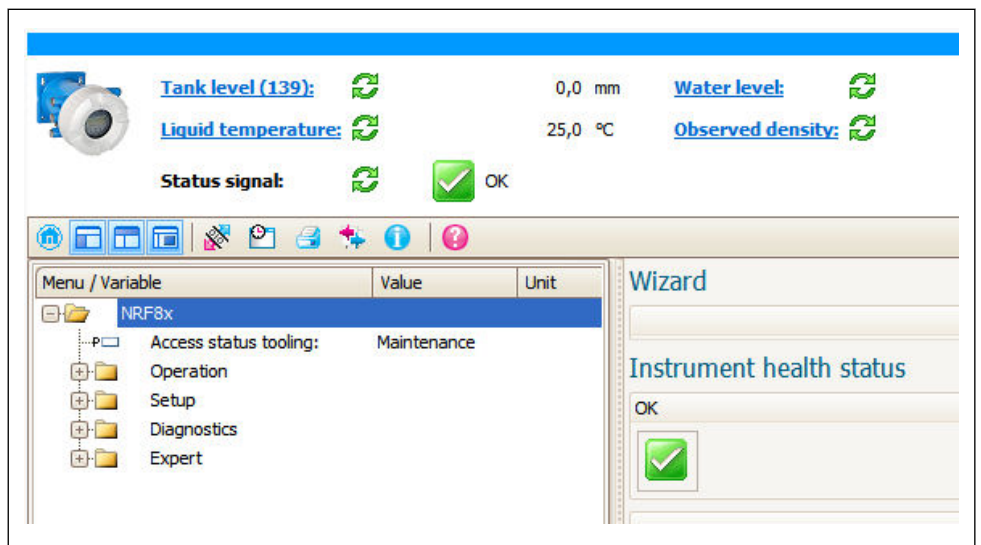

A0032934

↳ The device can be configured.

i The "Save/Restore" function

After a device configuration has been saved to a computer and restored to the device using the **Save/Restore** function of FieldCare, the device must be restarted by the following setting:

Setup → Advanced setup → Administration → Device reset = Restart device.

This ensures correct operation of the device after the restore.

8 System integration

8.1 Overview of the Device Description files (DTM)

To integrate the device via HART into FieldCare, a Device Description file (DTM) according to the following specification is required:

Manufacturer ID	0x11
Device type (NRF8x)	0x112F
HART specification	7.0
DD files	For information and files see: www.endress.com

9 Commissioning

9.1 Initial settings

9.1.1 Setting the display language

Setting the display language via the display module

1. While in the standard view (→  39), press "E". If required, select **Keylock off** from the context menu and press "E" again.
 - ↳ The **Language** parameter appears.
2. Open the **Language** parameter and select the display language.

Setting the display language via an operating tool (e.g. FieldCare)

1. Navigate to: Setup → Advanced setup → Display → Language
2. Select the display language.

 This setting only affects the language on the display module. To set the language in the operating tool use the language setting functionality of FieldCare or DeviceCare, respectively.

9.1.2 Setting the real-time clock

Setting the real-time clock via the display module

1. Navigate to: Setup → Advanced setup → Date / time → Set date
2. Use the following parameters to set the the real-time clock to the current date and time: **Year, Month, Day, Hour, Minutes**.

Setting the real-time clock via an operating tool (e.g. FieldCare)



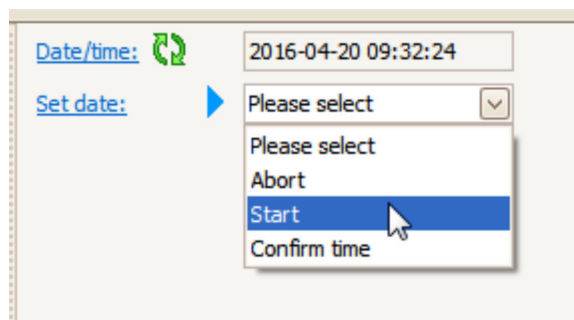

1. Navigate to: Setup → Advanced setup → Date / time

2.







Go to the **Set date** parameter and select the **Start** option.

3.

Date/time:		2016-04-20 09:34:25
Set date:	 	Please select 
Year:		2016
Month:		4
Day:		20
Hour:		9
Minute:		34

Use the following parameters to set the date and time: **Year, Month, Day, Hour, Minutes.**

















4.

Date/time:		2016-04-20 09:35:49
Set date:	 	Please select 
Year:		Please select
Month:		Abort
Day:		Start
Hour:		Confirm time 
Minute:		9
		34

Go to the **Set date** parameter and select the **Confirm time** option.

↳ The real-time clock is set to the current date and time.

9.2 Configuring the tank gauging application

Configuration of the inputs:	Description
HART inputs	→  58
NMT532/539 connected via HART	→  61
4-20mA inputs	→  62
RTD input	→  63
Digital inputs	→  65
Configuration of the data processing in the device:	Description
Linking input values to tank variables	→  67
Tank calculation: Direct Level Measurement	→  68
Tank calculation: Hybrid Tank Measurement System (HTMS)	→  69
Tank calculation: Hydrostatic Tank Gauging (HTG)	→  70
Tank calculation: Correction of the Hydrostatic Tank Deformation (HyTD)	→  73
Tank calculation: Thermal Tank Shell Correction (CTSh)	→  74
Alarms (limit evaluation)	→  75
Configuration of the signal output:	Description
4-20mA output	→  76
HART slave + 4-20mA output	→  77
Modbus	→  79
V1	→  80
Digital outputs	→  81

9.2.1 Configuration of the HART inputs

Connecting and addressing HART devices

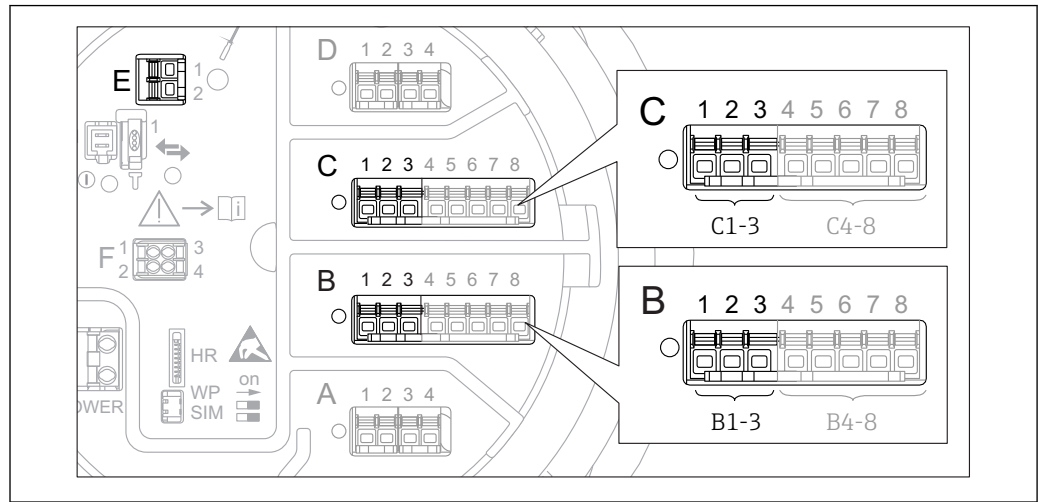

A0032955

26 Possible terminals for HART loops

- B Analog I/O module in slot B (availability depending on device version → 21)
 C Analog I/O module in slot C (availability depending on device version → 21)
 E HART Ex is output (available in all device versions)

i HART devices must be configured and given a unique HART address in the range from 1 to 15 via their own user interface before they are connected to the Tankside Monitor NRF81²⁾. Make sure they are connected as defined by the terminal assignment → 27. Devices with an address larger than 15 are not recognized by the Tankside Monitor.

Slot B or C: Setting the operating mode of the Analog I/O module

i This section is not relevant for the HART Ex is output (Slot E). This output always functions as a HART master for the connected HART slaves.

If HART devices are connected to an Analog I/O module (slot B or C in the terminal compartment), this module must be configured as follows:



1. Navigate to the submenu of the respective Analog I/O module: Setup → Advanced setup → Input/output → Analog I/O X1-3
2. Go to the **Operating mode** parameter (→ 138).
3. If only one HART device is connected to this loop:
 Select the **HART master+4..20mA input** option. In this case the 4-20mA signal can be used in addition to the HART signal. For the configuration of the 4-20mA input: → 62.
4. If up to 6 HART devices are connected to this loop:
 Select the **HART master** option.

Configuring the power supply for a connected Micropilot S FMR5xx

i This section is only relevant if a Micropilot S FMR5xx is connected to the Tankside Monitor.

2) The current software does not support HART devices with address 0 (zero).

The Tankside Monitor can provide the supply voltage for a connected Micropilot S FMR5xx. To configure this functionality, proceed as follows:





1. Make sure the FMR5xx is connected to the Analog I/O module as defined by the terminal assignment →  32.
2. Navigate to the submenu of the respective Analog I/O module: Setup → Advanced setup → Input/output → Analog IP X4-8
3. Go to the **Operating mode** parameter (→  132) and select the **Gauge power supply** option.

Defining the type of measured value

 This setting can be skipped for a connected Prothermo NMT5xx or Micropilot FMR5xx as for these devices the type of measured value is automatically recognized by the Tankside Monitor.

- 
 - The measured values can only be used in the system if the unit of the assigned HART variable fits the type of measured value. The HART variable assigned to **Output temperature**, for example, has to be in °C or °F.
 - A HART variable with unit "%" can not be used for **Output level**. Instead, the HART variable must be in mm, m, ft or in.

The type of measured value must be specified for each HART variable (PV, SV, TV and QV). To do so, proceed as follows:

1. Navigate to: Setup → Advanced setup → Input/output → HART devices
 - ↳ There is a submenu for each connected HART device.
2. For each device go to the corresponding submenu.
3. If the device measures a pressure:
 - Go to the **Output pressure** parameter (→  128) and specify which of the four HART variables contains the measured pressure. Only a HART variable with a pressure unit may be selected.
4. If the device measures a density:
 - Go to the **Output density** parameter (→  129) and specify which of the four HART variables contains the measured density. Only a HART variable with a density unit may be selected.
5. If the device measures a temperature:
 - Go to the **Output temperature** parameter (→  129) and specify which of the four HART variables contains the measured temperature. Only a HART variable with a temperature unit may be selected.
6. If the device measures the vapor temperature:
 - Go to the **Output vapor temperature** parameter (→  130) and specify which of the four HART variables contains the measured vapor temperature. Only a HART variable with a temperature unit may be selected.
7. If the device measures a level:
 - Go to the **Output level** parameter (→  130) and specify which of the four HART variables contains the measured level. Only a HART variable with a level unit (not "%") may be selected.

Disconnecting HART devices

When a HART device is disconnected from the device, it must also be logically removed as follows:

1. Navigate to Setup → Advanced setup → Input/output → HART devices → Forget device → Forget device

2. Select the HART device to be removed.

 This procedure is also necessary if a defective device is exchanged.

9.2.2 Configuration of a connected Prothermo NMT532/NMT539

If a Prothermo NMT532 or NMT539 temperature transmitter is connected via HART, it can be configured as follows:

1. Navigate to: Expert → Input/output → HART devices → HART Device(s) → NMT device config; here, **HART Device(s)** is the name of the connected Prothermo.
2. Go to the **Configure device?** parameter and select **Yes**.
3. Go to the **Bottom point** parameter and enter the position of the bottom temperature element (see picture below).

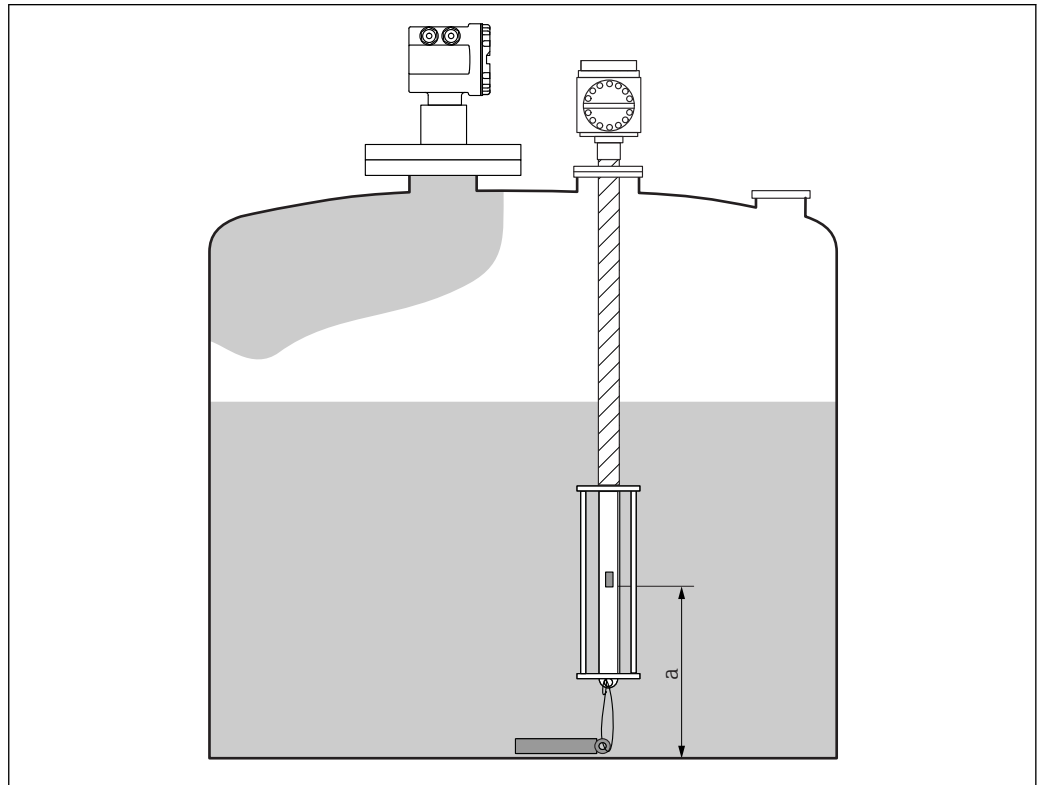

 27 Position of the bottom temperature element

a Distance from bottom temperature element to zero reference (tank bottom or datum plate). The standard factory default setting is 500 mm (19.69 in), and it can be adjusted according to the actual installation.

-  To check the temperatures measured by the individual elements, go to the following submenu: Operation → Temperature → NMT element values → Element temperature
There is a **Element temperature X** parameter for each element of the Prothermo.

9.2.3 Configuration of the 4-20mA inputs

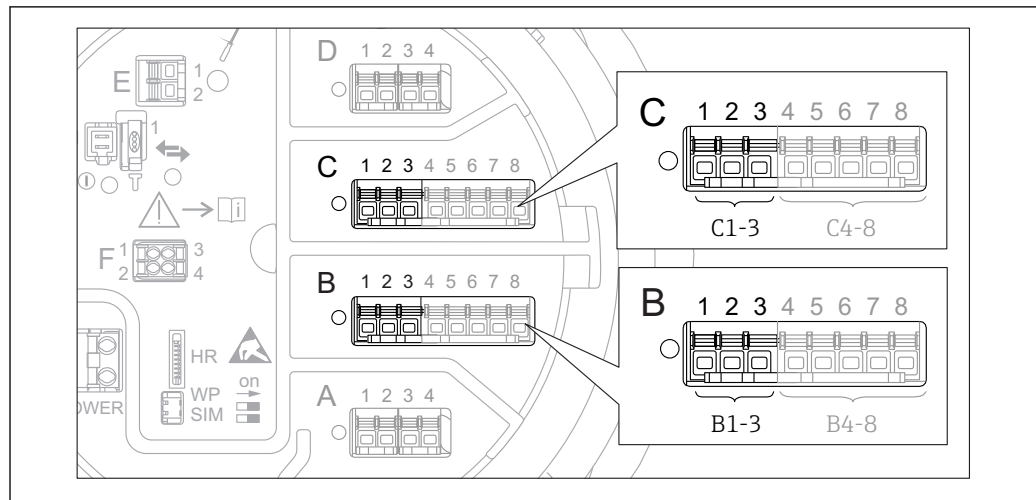

28 Possible locations of the Analog I/O modules, which can be used as a 4-20mA input. The order code of the device determines which of these modules is actually present → 21.

For each Analog I/O module to which a 4-20mA device is connected, proceed as follows:

1. Make sure the 4-20mA devices are connected as defined by the terminal assignment → 27.
2. Navigate to the submenu of the respective Analog I/O module: Setup → Advanced setup → Input/output → Analog I/O X1-3
3. Go to the **Operating mode** parameter (→ 138) and select **4..20mA input** or **HART master+4..20mA input**.
4. Go to the **Process variable** parameter (→ 144) and specify which process variable is transmitted by the connected device.
5. Go to the **Analog input 0% value** parameter (→ 144) and define which value of the process variable corresponds to an input current of 4 mA (see diagram below).
6. Go to the **Analog input 100% value** parameter (→ 144) and define which value of the process variable corresponds to an input current of 20 mA (see diagram below).
7. Go to the **Process value** parameter (→ 145) and check whether the indicated value matches the actual value of the process variable.

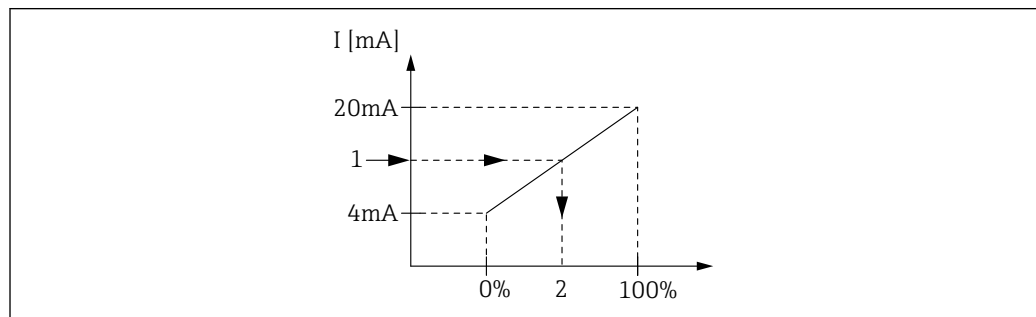

29 Scaling of the 4-20mA input to the process variable

- 1 Input value in mA
- 2 Process value

i The **Analog I/O** submenu contains additional parameters for a more detailed configuration of the Analog Input. For a description refer to : → 138

9.2.4 Configuration of a connected RTD

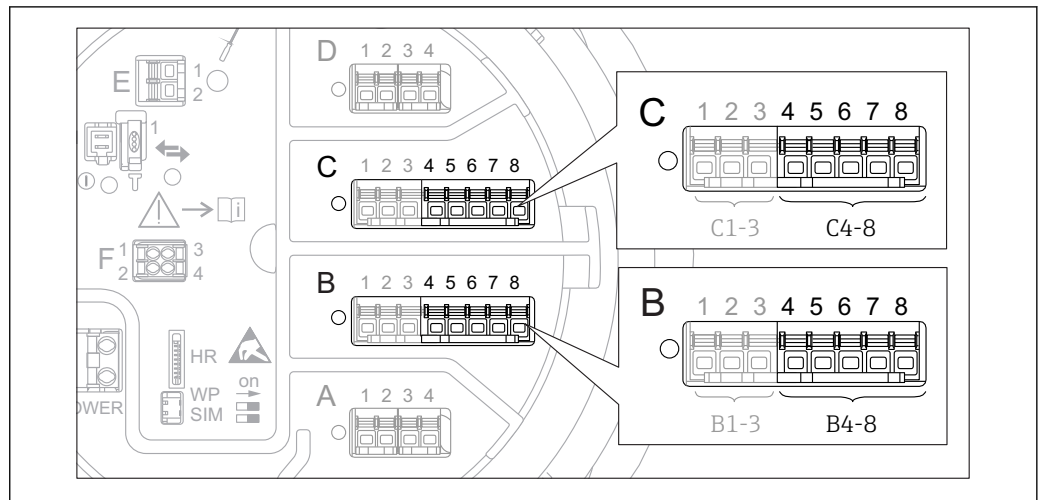

30 Possible locations of the Analog I/O modules, to which an RTD can be connected. The order code of the device determines which of these modules is actually present → 21.

1. Make sure the RTD is connected as defined by the terminal assignment → 31.
2. Navigate to the submenu of the respective Analog I/O module: Setup → Advanced setup → Input/output → Analog IP X4-8.
3. Go to the **RTD type** parameter (→ 132) and specify the type of the connected RTD.

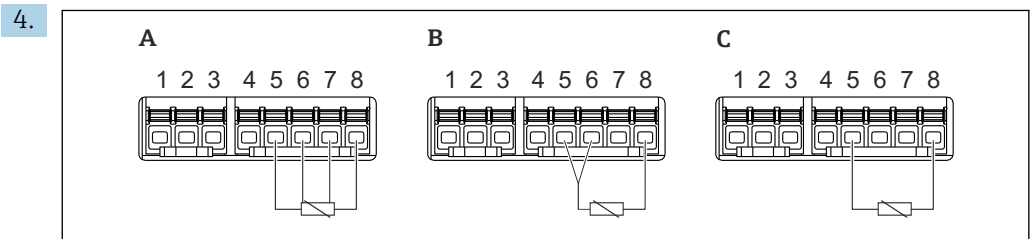

31 RTD connection types

- A 2 wire RTD connection
- B 3 wire RTD connection
- C 4 wire RTD connection

Go to the **RTD connection type** parameter (→ 133) and specify the type of connection of the RTD (2-, 3- or 4-wire).

5. Go to the **Input value** parameter (→ 135) and check whether the indicated temperature matches the actual temperature.
6. Go to the **Minimum probe temperature** parameter (→ 135) and specify the minimum approved temperature of the connected RTD.
7. Go to the **Maximum probe temperature** parameter (→ 135) and specify the maximum approved temperature of the connected RTD.

8.

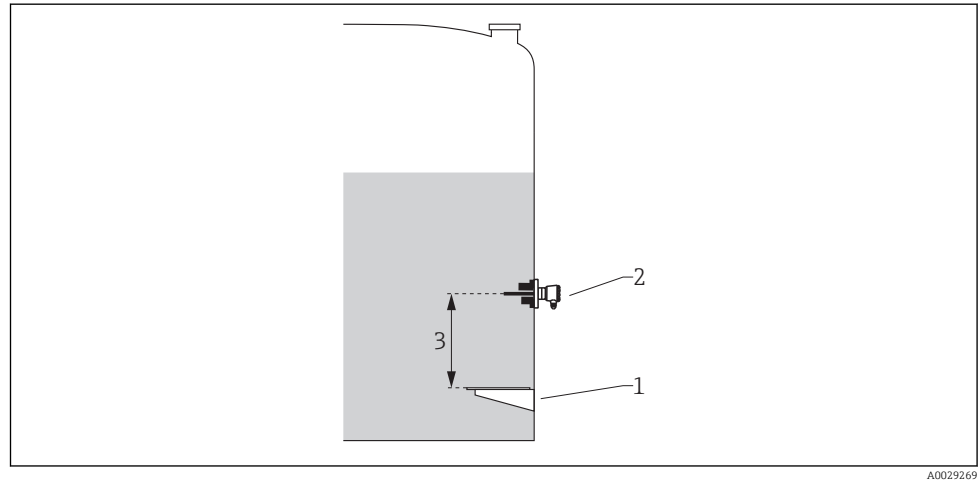

- 1 Datum plate
- 2 RTD
- 3 Probe position (→ [136](#))

Go to the **Probe position** parameter and enter the mounting position of the RTD (measured from the datum plate).

- ↳ This parameter, in conjunction with the measured level, determines whether the measured temperature refers to the product or to the gas phase.

Offset for resistance and/or temperature



An offset for the resistance or the temperature can be defined in the following submenu: Expert → Input/output → Analog IP X4-8.

- **Ohms offset** is added to the measured resistance before the calculation of the temperature.
- **Temperature offset after conversion** is added to the measured temperature.

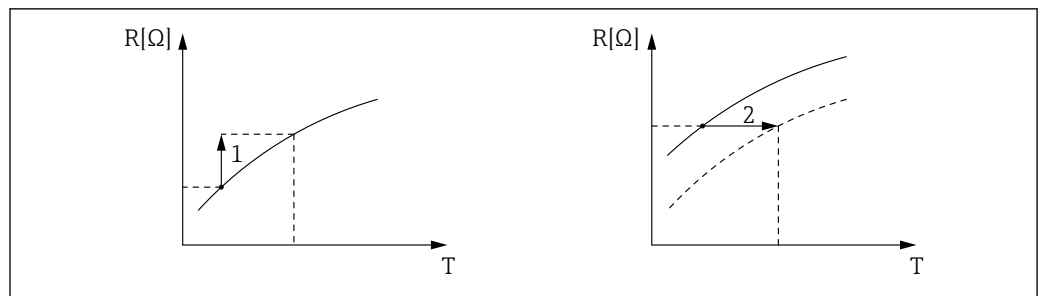

- 1 Ohms offset
- 2 Temperature offset after conversion

9.2.5 Configuration of the digital inputs

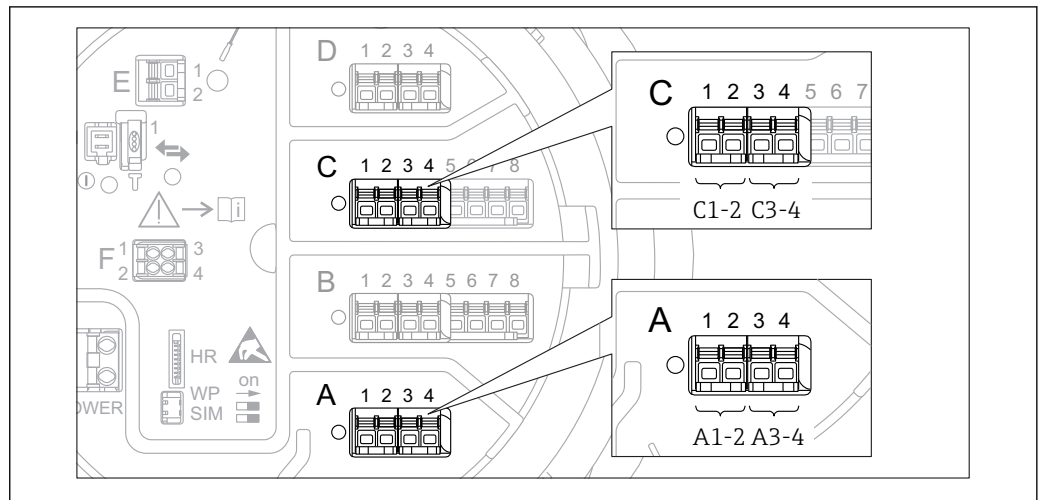

32 Possible locations of the Digital I/O modules (examples); the order code defines the number and location of digital input modules → 21.

There is a **Digital Xx-x** submenu for each digital I/O module of the device. "X" designates the slot in the terminal compartment, "x-x" the terminals within this slot. The most important parameters of this submenu are **Operating mode** and **Contact type**.

The "Operating mode" parameter

Setup → Advanced setup → Input/output → Digital Xx-x → Operating mode

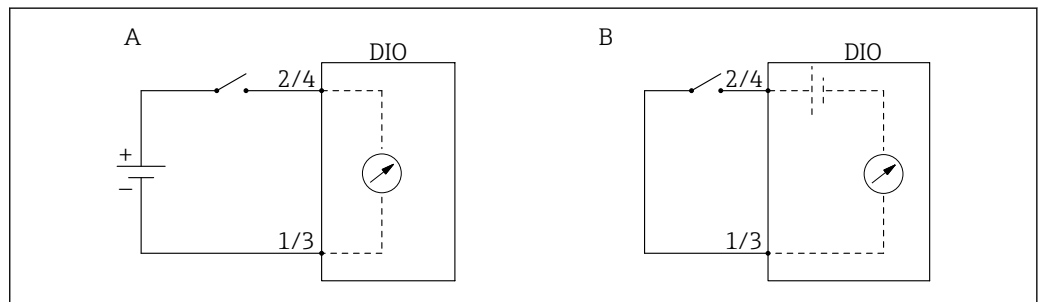

A "Operating mode" = "Input passive"
 B "Operating mode" = "Input active"

Meaning of the options

- **Input passive**

The DIO module measures the voltage provided by an external source. Depending on the status of the external switch, this voltage is 0 at the input (switch open) or exceeds a certain limit voltage (switch closed). These two states represent the digital signal.

- **Input active**



The DIO module provides a voltage and uses it to detect whether the external switch is open or closed.

The "Contact type" parameter

Setup → Advanced setup → Input/output → Digital Xx-x → Contact type

This parameter determines how the state of the external switch is mapped to the internal states of the DIO module:

State of the external switch	Internal state of the DIO module	
	Contact type = Normally open	Contact type = Normally closed
Open	Inactive	Active
Closed	Active	Inactive
Behavior in special situations:		
During start-up	Unknown	Unknown
Fault in measurement	Error	Error

- 
 - The internal state of the Digital Input can be transferred to a Digital Output or can be used to control the measurement.
 - The **Digital Xx-x** submenu contains additional parameters for a more detailed configuration of the Digital Input. For a description refer to →  148.

9.2.6 Linking input values to tank variables

Measured values must be linked to tank variables before they can be used in the Tank Gauging application. This is done by defining the source of each tank variable in the following parameters:

Tank variable	Parameter defining the source of this variable
Product level	<ul style="list-style-type: none"> ▪ Setup → Level source ▪ Setup → Advanced setup → Application → Tank configuration → Level → Level source
Bottom water level	Setup → Advanced setup → Application → Tank configuration → Level → Water level source
Average or spot temperature of the product	<ul style="list-style-type: none"> ▪ Setup → Liquid temp source ▪ Setup → Advanced setup → Application → Tank configuration → Temperature → Liquid temp source
Temperature of the air surrounding the tank	Setup → Advanced setup → Application → Tank configuration → Temperature → Air temperature source
Temperature of the vapor above the product	Setup → Advanced setup → Tank configuration → Temperature → Vapor temp source
Density of the product	Setup → Advanced setup → Application → Tank configuration → Density → Observed density source
Bottom pressure (P1)	Setup → Advanced setup → Application → Tank configuration → Pressure → P1 (bottom) source
Middle pressure (P2)	Setup → Advanced setup → Application → Tank configuration → Pressure → P2 (middle) source
Top pressure (P3)	Setup → Advanced setup → Application → Tank configuration → Pressure → P3 (top) source



Depending on the application not all these parameters will be relevant in a given situation.

9.2.7 Tank calculation: Direct level measurement

If no tank calculation is configured, level and temperature are measured directly.

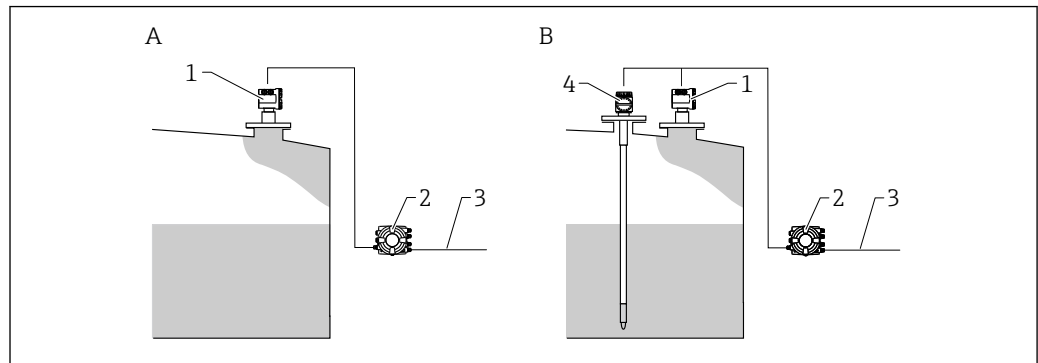

- A Direct level measurement (without temperature)
 B Direct level and temperature measurement
 1 Level transmitter (typically FMR540 or FMR51)
 2 Tankside Monitor
 3 To inventory management system
 4 Temperature transmitter

1. Navigate to: "Setup → Level source" and specify from which device the level is obtained.
2. If a temperature transmitter is connected:
 Navigate to: "Setup → Liquid temp source" and specify from which device the temperature is obtained.

9.2.8 Tank calculation: Hybrid tank measurement system (HTMS)

HTMS uses level and pressure measurements to calculate the density of the medium.

i In non-atmospheric (i.e. pressurized) tanks it is recommended to use the **HTMS P1+P3** mode. Two pressure sensors are required in this case. In atmospheric (i.e. unpressurized) tanks the **HTMS P1** with only one pressure sensor is sufficient.

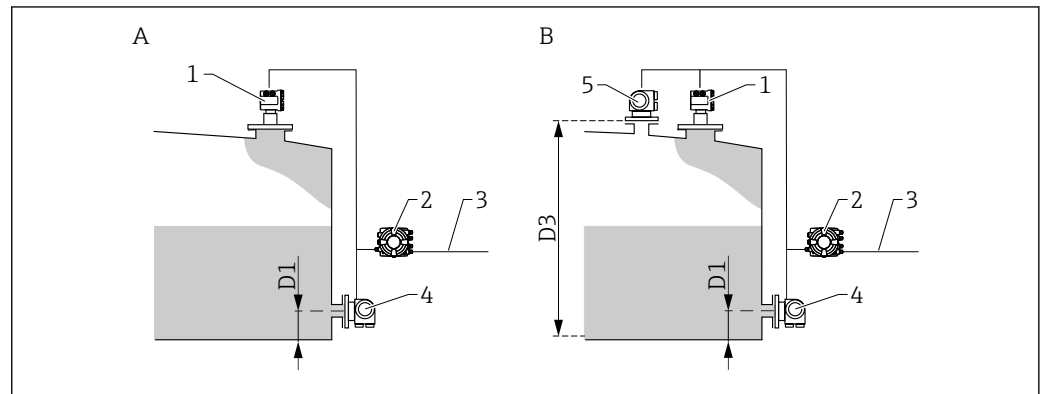

- A The "HTMS P1" measurement mode
 B The "HTMS P1+P3" measurement mode
 D1 P1 position
 D3 P3 position
 1 Level transmitter (e.g. typically FMR540 or FMR51)
 2 Tankside Monitor
 3 To inventory management system
 4 Pressure sensor (bottom)
 5 Pressure sensor (top)

1. Navigate to Setup → Advanced setup → Application → Tank configuration → Level
2. Go to **Level source** (→ 📖 122) and specify from which device the level is obtained.
3. Navigate to Setup → Advanced setup → Application → Tank configuration → Pressure
4. Go to **P1 (bottom) source** (→ 📖 181) and specify from which device the bottom pressure (P1) is obtained.
5. If a top pressure transmitter (P3) is connected:
 Go to **P3 (top) source** (→ 📖 185) and specify from which device the bottom pressure (P1) is obtained.
6. Navigate to: Setup → Advanced setup → Application → Tank calculation → HTMS
7. Go to **HTMS mode** (→ 📖 210) and specify the HTMS mode.
8. Navigate to Setup → Advanced setup → Application → Tank configuration → Density
9. Go to **Observed density source** (→ 📖 179) and select **HTMS**.
10. Use the other parameters of the **HTMS** submenu to configure the calculation. For a detailed description: → 📖 208

9.2.9 Tank calculation: Hydrostatic tank gauging (HTG)

Hydrostatic Tank Gauging (HTG) is a method to calculate the level and the density of the product inside a tank using pressure measurements only. The pressure is measured at different heights of the tank using one, two or three pressure sensors. With these data the density or the level of the product (or both) can be calculated.

Overview of the HTG parameters

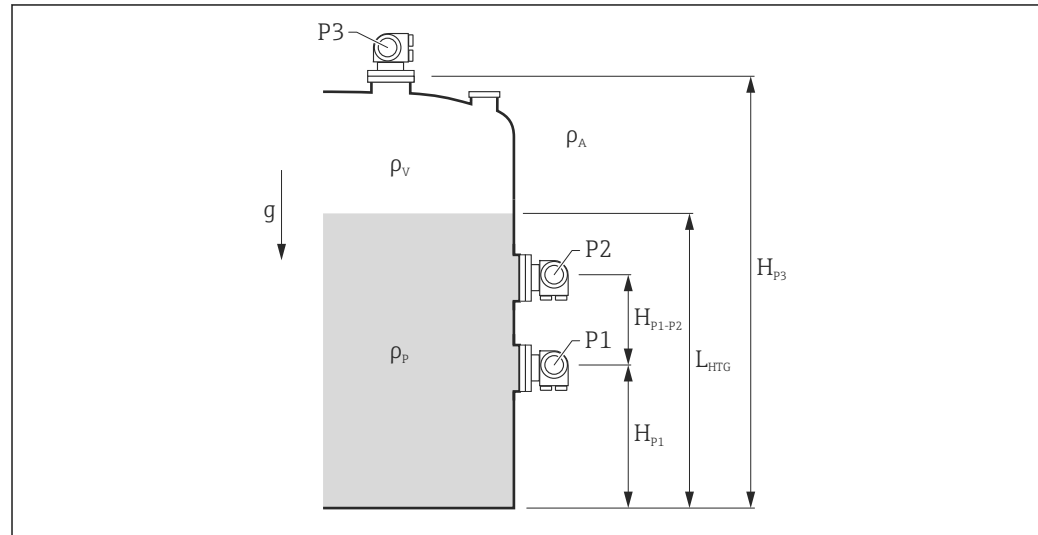

33 HTG parameters

A0028711

Parameter	Navigation path
P1 (Bottom pressure)	Setup → Advanced setup → Application → Tank configuration → Pressure → P1 (bottom)
H_{P1} (Position of P1 sensor)	Setup → Advanced setup → Application → Tank configuration → Pressure → P1 position
P2 (Middle pressure)	Setup → Advanced setup → Application → Tank configuration → Pressure → P2 (middle)
H_{P1-P2} (Distance between P1 and P2 sensors)	Setup → Advanced setup → Application → Tank configuration → Pressure → P1-2 distance
P3 (Top pressure)	Setup → Advanced setup → Application → Tank configuration → Pressure → P3 (top)
H_{P3} (Position of P3 sensor)	Setup → Advanced setup → Application → Tank configuration → Pressure → P3 position
ρ_P (Density of the product ¹⁾)	<ul style="list-style-type: none"> ■ Read-only: Setup → Advanced setup → Application → Tank calculation → HTG → Density value ■ Writable: Setup → Advanced setup → Application → Tank calculation → HTG → Manual density
ρ_V (Vapor density)	Setup → Advanced setup → Application → Tank configuration → Density → Vapor density
ρ_A (Ambient air temperature)	Setup → Advanced setup → Application → Tank configuration → Density → Air density
g (Local gravity)	Expert → Application → Tank Calculation → Local gravity
L_{HTG} (Calculated level)	Setup → Advanced setup → Application → Tank calculation → HTG → Tank level

1) Depending on the **HTG mode** parameter this is a writable or a read-only parameter.

Selecting the HTG mode

1. Navigate to Setup → Advanced setup → Application → Tank calculation → HTG
2. Go to the **HTG mode** parameter (→ ⓘ 205) and select the mode according to the following table.

HTG mode	Measured variables	Required additional parameters	Calculated variables
P1 only	P1	<ul style="list-style-type: none"> ▪ ρ_P ▪ g ▪ H_{P1} 	L_{HTG}
P1 + P3	<ul style="list-style-type: none"> ▪ P1 ▪ P3 	<ul style="list-style-type: none"> ▪ ρ_P ▪ ρ_V ▪ ρ_A ▪ g ▪ H_{P1} ▪ H_{P3} 	L_{HTG} (more precise calculation for pressurized tanks)
P1 + P2	<ul style="list-style-type: none"> ▪ P1 ▪ P2 	<ul style="list-style-type: none"> ▪ ρ_A ▪ g ▪ H_{P1} ▪ H_{P1-P2} 	<ul style="list-style-type: none"> ▪ ρ_P ▪ L_{HTG}
P1 + P2 + P3	<ul style="list-style-type: none"> ▪ P1 ▪ P2 ▪ P3 	<ul style="list-style-type: none"> ▪ ρ_V ▪ ρ_A ▪ g ▪ H_{P1} ▪ H_{P1-P2} ▪ H_{P3} 	<ul style="list-style-type: none"> ▪ ρ_P ▪ L_{HTG} (more precise calculation for pressurized tanks)

Assigning the P1 (bottom) pressure sensor

1. Navigate to : Setup → Advanced setup → Application → Tank configuration → Pressure
2. Go to the **P1 (bottom) source** parameter (→ ⓘ 181) and select the device from which the bottom pressure is obtained.
3. Go to the **P1 (bottom)** parameter (→ ⓘ 118) and check whether the indicated pressure matches the actual pressure at the P1 position. If necessary, the indicated pressure can be corrected by the **P1 offset** parameter.
4. Go to the **P1 position** parameter (→ ⓘ 182) and enter the distance from the datum plate to the P1 sensor.
5. Go to the **P1 abs / rel** parameter (→ ⓘ 182) and specify whether the P1 sensor measures an absolute or a relative pressure.

Assigning the P2 (middle) pressure sensor

 This procedure is only required for the following HTG modes:





- P1 + P2
- P1 + P2 + P3

1. Navigate to Setup → Advanced setup → Application → Tank configuration → Pressure
2. Go to the **P2 (middle) source** parameter (→ ⓘ 183) and select the device from which the middle pressure is obtained.
3. Go to the **P2 (middle)** parameter (→ ⓘ 118) and check whether the indicated pressure matches the actual pressure at the P2 position. If necessary, the indicated pressure can be corrected by the **P2 offset** parameter (→ ⓘ 184).
4. Go to the **P1-2 distance** parameter (→ ⓘ 184) and enter the distance between the P1 and P2 sensors.
5. Go to the **P2 abs / rel** parameter (→ ⓘ 184) and specify whether the P2 sensor measures an absolute or a relative pressure.

Assigning the P3 (top) sensor

 This procedure is only required for the following HTG mode:

- P1 + P3
- P1 + P2 + P3



1. Navigate to Setup → Advanced setup → Application → Tank configuration → Pressure
2. Go to the **P3 (top) source** parameter (→  185) and select the device from which the top pressure is obtained.
3. Go to the **P3 (top)** parameter (→  118) and check whether the indicated pressure matches the actual pressure at the P3 position. If necessary, the indicated pressure can be corrected by the **P3 offset** parameter (→  186).
4. Go to the **P3 position** parameter (→  186) and enter the distance from the datum plate to the P3 sensor.
5. Go to the **P3 abs / rel** parameter (→  186) and specify whether the P3 sensor measures an absolute or a relative pressure.

Selecting HTG as the level source

1. Navigate to Setup → Advanced setup → Application → Tank configuration → Level
2. Go to the **Operation mode** parameter and select **HTG**.

Supplementary specifications

1. If the ambient pressure deviates considerably from 1 bar (14.5 psi):
Navigate to Setup → Advanced setup → Application → Tank configuration → Pressure
2. Go to the **Ambient pressure** parameter (→  187) and specify the ambient pressure.

 The **HTG** submenu contains additional parameters for a more detailed configuration of the HTG calculation. For details: →  198

9.2.10 Tank calculation: Hydrostatic Tank Deformation (HyTD)

Hydrostatic Tank Deformation can be used to compensate the vertical movement of the Gauge Reference Height (GRH) due to bulging of the tank shell caused by the hydrostatic pressure exerted by the liquid stored in the tank. The compensation is based on a linear approximation obtained from manual hand dips at several levels divided over the full range of the tank.

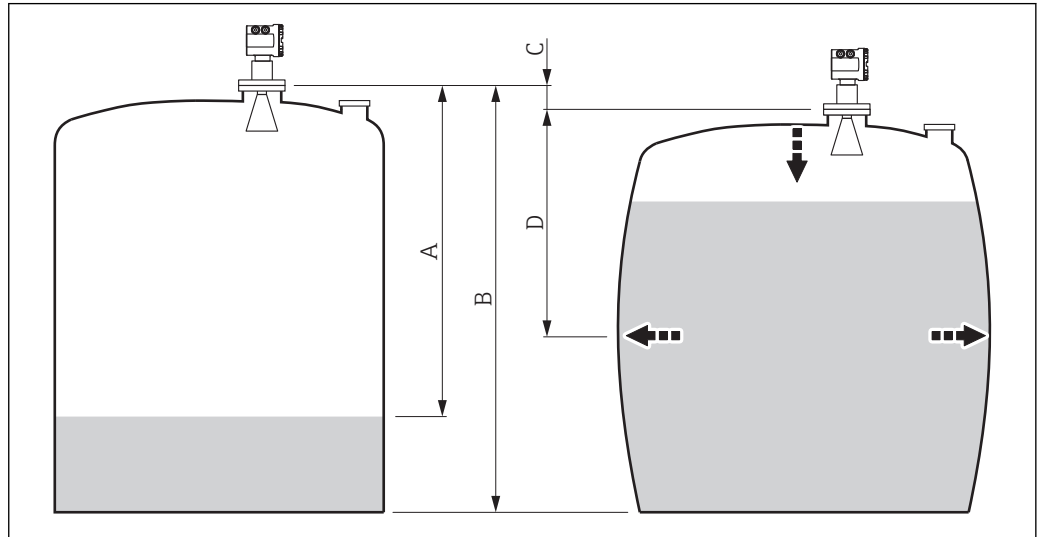



34 Correction of the hydrostatic tank deformation (HyTD)

- A "Distance" (tank nearly empty)
- B Gauge Reference Height (GRH)
- C HyTD correction value
- D "Distance" (tank filled)

- i** This mode should not be used in conjunction with HTG as with HTG the level is not measured relative to the gauge reference height.
- i** The Correction of the Hydrostatic Tank Deformation is configured in the **HyTD** submenu (→ 190)

9.2.11 Tank calculation: Thermal tank shell correction (CTSh)

CTSh (correction for the thermal expansion of the tank shell) compensates for effects on the Gauge Reference Height (GRH) and on the expansion or contraction of the measuring wire due to temperature effects on the tank shell or stilling well. The temperature effects are separated into two parts, respectively affecting the 'dry' and 'wetted' part of the tank shell or stilling well. The correction function is based on thermal expansion coefficients of steel and insulation factors for both the 'dry' and 'wet' parts of the wire and the tank shell. The temperatures used for the correction can be selected from on manual or measured values.

-  This correction is recommended for the following situations:
 - if the operating temperature deviates considerably from the temperature during calibration ($\Delta T > 10\text{ }^{\circ}\text{C}$ (18 °F))
 - for extremely high tanks
 - for refrigerated, cryogenic or heated applications
-  As the use of this correction will influence the innage level reading, it is recommended to ensure the manual hand dip and level verification procedures are being conducted correctly before enabling this correction method.
-  This mode cannot be used in conjunction with HTG because the level is not measured relative to the gauge reference height with HTG.

9.2.12 Configuration of the alarms (limit evaluation)

A limit evaluation can be configured for up to 4 tank variables. The limit evaluation issues an alarm if the value exceeds an upper limit or falls below a lower limit, respectively. The limit values can be defined by the user.

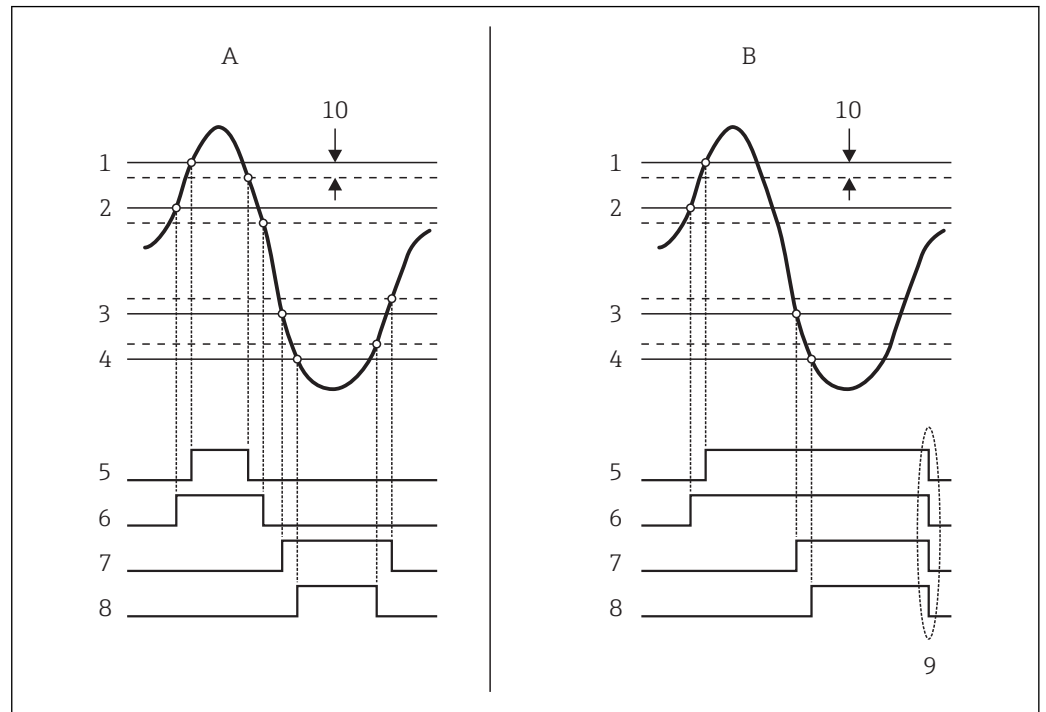

35 Principle of the limit evaluation

- A Alarm mode = On
- B Alarm mode = Latching
- 1 HH alarm value
- 2 H alarm value
- 3 L alarm value
- 4 LL alarm value
- 5 HH alarm
- 6 H alarm
- 7 L alarm
- 8 LL alarm
- 9 "Clear alarm" = "Yes" or power off-on
- 10 Hysteresis

The limit evaluation is configured in the **Alarm 1 to 4** submenus.

Navigation path: Setup → Advanced setup → Alarm → Alarm 1 to 4

i For **Alarm mode = Latching** all alarms remain active until the user selects **Clear alarm = Yes** or the power is switched off and on.

9.2.13 Configuration of the 4-20mA output

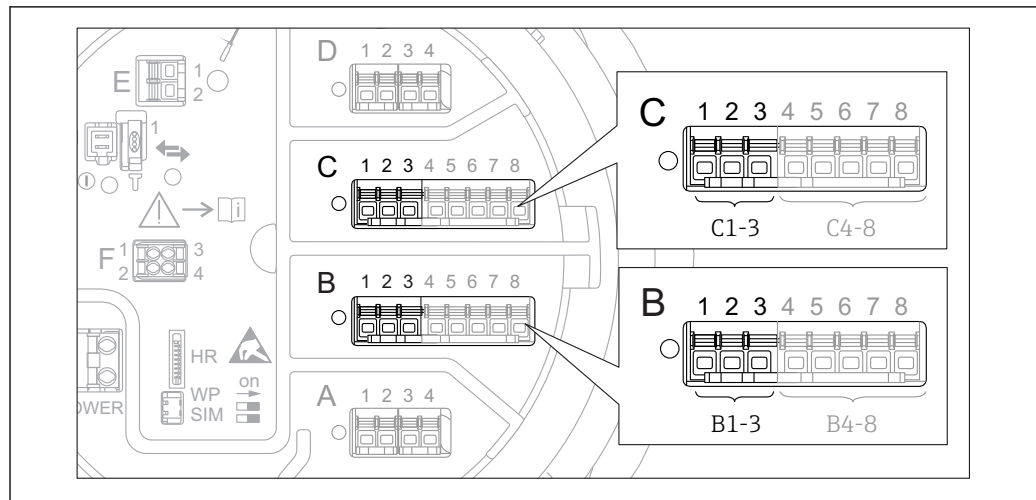

36 Possible locations of the Analog I/O modules, which can be used as a 4-20mA output. The order code of the device determines which of these modules is actually present → 21.

Each Analog I/O module of the device can be configured as a 4...20mA analog output. To do so, proceed as follows:

1. Navigate to: Setup → Advanced setup → Input/output → Analog I/O X1-3.
2. Go to the **Operating mode** parameter and select **4..20mA output** or **HART slave +4..20mA output**³⁾.
3. Go to the **Analog input source** parameter and select the tank variable which is to be transmitted via the 4...20mA output.
4. Go to the **0 % value** parameter and enter the value of the selected tank variable which will be mapped to 4 mA.
5. Go to the **100 % value** parameter and enter the value of the selected tank variable which will be mapped to 20 mA.

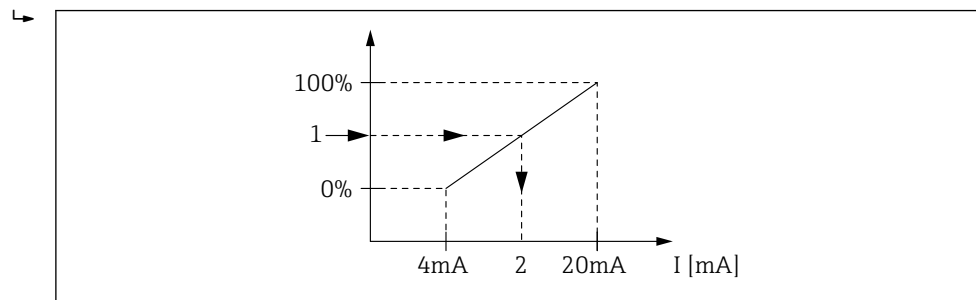

37 Scaling of the tank variable to the output current

- 1 Tank variable
- 2 Output current



i After startup of the device, as long as the assigned tank variable is not yet available, the output current assumes the defined error value.

i The **Analog I/O** submenu contains more parameters which can be used for a more detailed configuration of the analog output. For a description see → 138

3) "HART slave +4..20mA output" means that the Analog I/O module serves as a HART slave which cyclically sends up to four HART variables to a HART master. For the configuration of the HART output: → 77

9.2.14 Configuration of the HART slave + 4-20mA output

If **Operating mode = HART slave +4..20mA output** has been selected for an Analog I/O module, it serves as a HART slave which sends up to four HART variables to a HART master.

 The 4-20 mA signal can be used in this case, too. For its configuration: →  76

Standard case: PV = 4-20mA signal

By default, the Primary Variable (PV) is identical to the tank variable transmitted by the 4-20mA output. To define the other HART variables and to configure the HART output in more detail, proceed as follows:

1. Navigate to: Setup → Advanced setup → Communication → HART output → Configuration
2. Go to the **System polling address** parameter and set the HART slave address of the device.
3. Use the following parameters to assign tank variables to the second to fourth HART variable: **Assign SV**, **Assign TV**, **Assign QV**.
 - ↳ The four HART variables are transmitted to a connected HART Master.

Special case: PV ≠ 4-20mA signal

In exceptional cases it might be required that the Primary Variable (PV) transmits a different tank variable than the 4-20mA output. This is configured as follows.

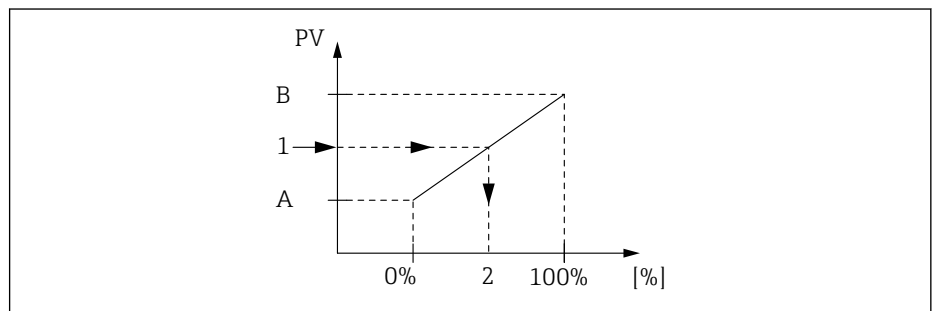

1. Navigate to: Setup → Advanced setup → Communication → HART output → Configuration
2. Go to the **PV source** parameter and select **Custom**.
 - ↳ The following additional parameters appear in the submenu: **Assign PV**, **0 % value**, **100 % value** and **PV mA selector**.
3. Go to the **Assign PV** parameter and select the tank variable to be transmitted as the Primary Variable (PV).
4. Use the **0 % value** and **100 % value** parameters to define a range for the PV. The **Percent of range** parameter indicates the percentage for the actual value of the PV. It is included in the cyclical output to the HART master.
 - ↳



 38 Scaling of the tank variable to the percentage

- A 0 % value
- B 100 % value
- 1 Primary variable (PV)
- 2 Percent of range

5. Use the **PV mA selector** parameter to define whether the output current of an Analog I/O module is to be included in the cyclical HART output.

-  After startup of the device, as long as the assigned tank variable is not yet available, the output current assumes the defined error value.
-  The **PV mA selector** parameter does not influence the output current at the terminals of the Analog I/O module. It only defines whether the value of this current is part of the HART output or not.

9.2.15 Configuration of the Modbus output

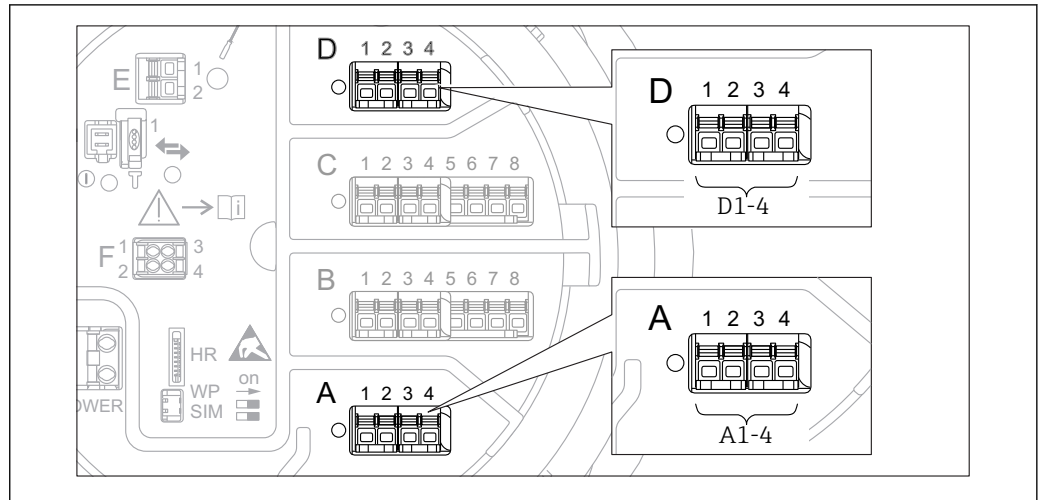

39 Possible locations of the Modbus modules (examples); depending on the device version these modules may also be in slot B or C → 21.

The Tankside Monitor NRF81 acts as a Modbus slave. Measured or calculated tank values are stored in registers which can be requested by a Modbus master.

The following submenu is used to configure the communication between the device and the Modbus master:

Setup → Advanced setup → Communication → Modbus X1-4 → Configuration (→ 154)

9.2.16 Configuration of the V1 output

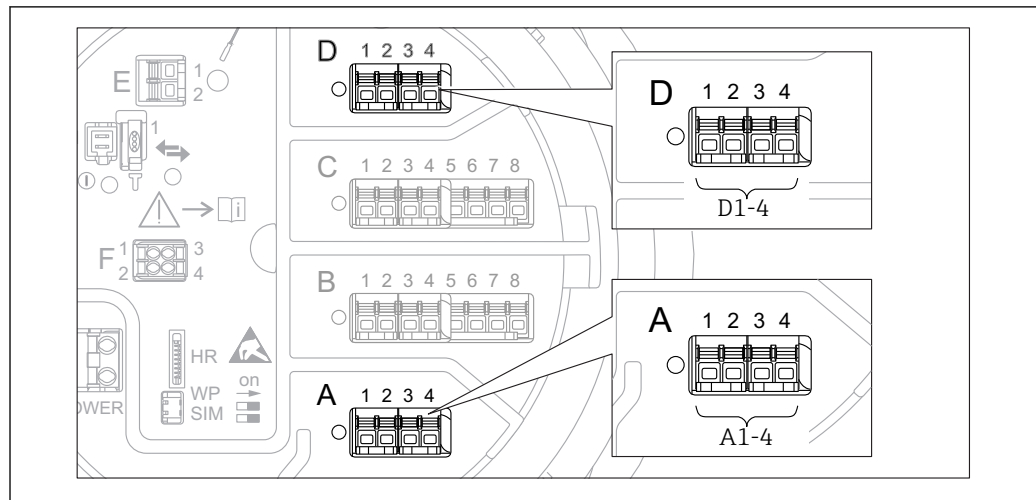

A0031200

40 Possible locations of the V1 modules (examples); depending on the device version these modules may also be in slot B or C → 21.

The following submenus are used to configure the V1 communication between the device and the control system:

- Setup → Advanced setup → Communication → V1 X1-4 → Configuration (→ 157)
- Setup → Advanced setup → Communication → V1 X1-4 → V1 input selector (→ 160)

9.2.17 Configuration of the digital outputs

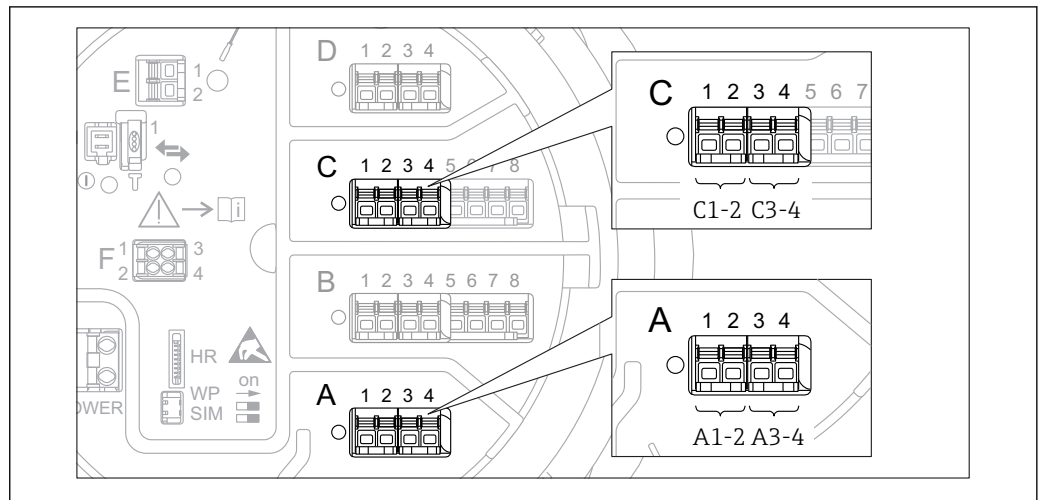

A0026424

41 Possible locations of the Digital I/O modules (examples); the order code defines the number and location of Digital I/O modules → 21.

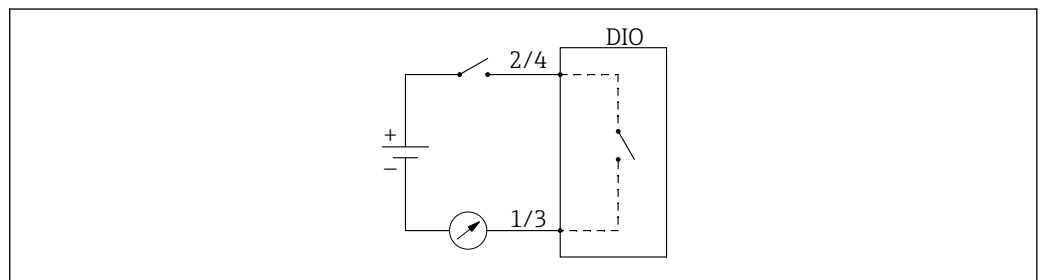

A0033029

42 Usage of the Digital I/O module as a digital output

There is a **Digital Xx-x** submenu for each digital I/O module of the device. "X" designates the slot in the terminal compartment, "x-x" the terminals within this slot. The most important parameters of this submenu are **Operating mode**, **Digital input source** and **Contact type**.



A digital output can be used to

- output the state of an alarm (if an alarm has been configured → 75)
- transmit the status of a digital input (if a digital input has been configured → 65)

To configure a digital output, proceed as follows:

1. Navigate to Setup → Advanced setup → Input/output → Digital Xx-x, where Xx-x designates the digital I/O module to be configured.
2. Go to the **Operating mode** parameter and select the **Output passive** option.
3. Go to the **Digital input source** parameter and select the alarm or digital input to be transmitted.
4. Go to the **Contact type** parameter and select how the internal state of the alarm or digital input is to be mapped to the digital output (see table below).

<ul style="list-style-type: none"> ▪ State of the alarm ▪ Internal state of the digital input 	Switching state of the digital output	
	Contact type = Normally open	Contact type = Normally closed
Inactive	Open	Closed
Active	Closed	Open

- 
 - For SIL applications, **Contact type** is automatically set to **Normally closed** by the device when starting the SIL confirmation procedure.
 - In case of a power supply failure, the switching state is always "open", irrespective of the selected option.
 - The **Digital Xx-x** submenu contains additional parameters for a more detailed configuration of the Digital Input. For a description refer to →  148.

9.3 Advanced settings



For a more detailed configuration of the signal inputs, the tank calculations and the signal outputs refer to the **Advanced setup** submenu (→  124).

9.4 Simulation

To check the correct configuration of the device and of the control system, it is possible to simulate different situations (measured values, diagnostic messages etc.). See the **Simulation** submenu (→  243) for details.

9.5 Protecting settings from unauthorized access

There are two possibilities to protect the settings from unauthorized access:

- By an access code (→  47)
This locks the access via the display and operating module.
- By the protection switch (→  48)
This locks the access to W&M-related parameters by any user interface (display and operating module, FieldCare, other configuration tools).

10 Operation

10.1 Reading off the device locking status

Depending on the locking state of the device some operations may be locked. The current locking status is indicated at: Setup → Advanced setup → Locking status. The following table summarizes the different locking statuses:

Locking status	Meaning	Unlocking procedure
Hardware locked	The device is locked by the write-protection switch in the terminal compartment.	→ 48
SIL locked	The device is in SIL-locked mode.	See the SIL Safety manual
CT active - all parameters	The custody transfer mode is active.	→ 48
WHG locked (in preparation)	The device is in WHG-locked mode.	in preparation
Temporarily locked	Write access to the parameters is temporarily lock due to device-internal processing (e.g. data upload/download, reset). Once the internal processing has been completed, the parameters can be changed again.	Wait for completion of the device-internal processing.

A locking is indicated by the write protection symbol in the header of the display:

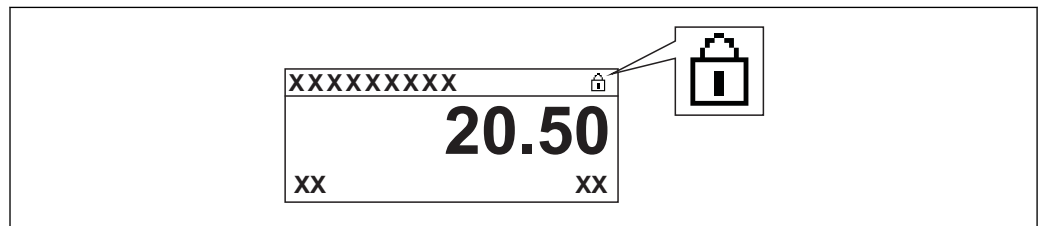

A0015870

10.2 Reading off measured values

Tank values can be read off in the following submenus:

- Operation → Level
- Operation → Temperature
- Operation → Density
- Operation → Pressure

11 Diagnostics and troubleshooting

11.1 General trouble shooting

11.1.1 General errors

Error	Possible cause	Remedial action
Device does not respond.	Supply voltage not connected.	Connect the correct voltage.
	The cables do not contact the terminals properly.	Ensure electrical contact between the cable and the terminal.
Values on the display invisible	The plug of the display cable is not connected correctly.	Connect the plug correctly.
	Display is defective.	Replace display.
	Display contrast too low.	Set Setup → Advanced setup → Display → Contrast display to a value ≥ 60 %.
"Communication error" is indicated on the display when starting the device or connecting the display	Electromagnetic interference	Check grounding of the device.
	Broken display cable or display plug.	Exchange display.
CDI communication does not work.	Wrong setting of the COM port on the computer.	Check the setting of the COM port on the computer (e.g. FieldCare) and change it if necessary.
Device measures incorrectly.	Parametrization error	Check and adjust parameterization.

11.2 Diagnostic information on local display

11.2.1 Diagnostic message

Faults detected by the self-monitoring system of the measuring device are displayed as a diagnostic message in alternation with the measured value display.

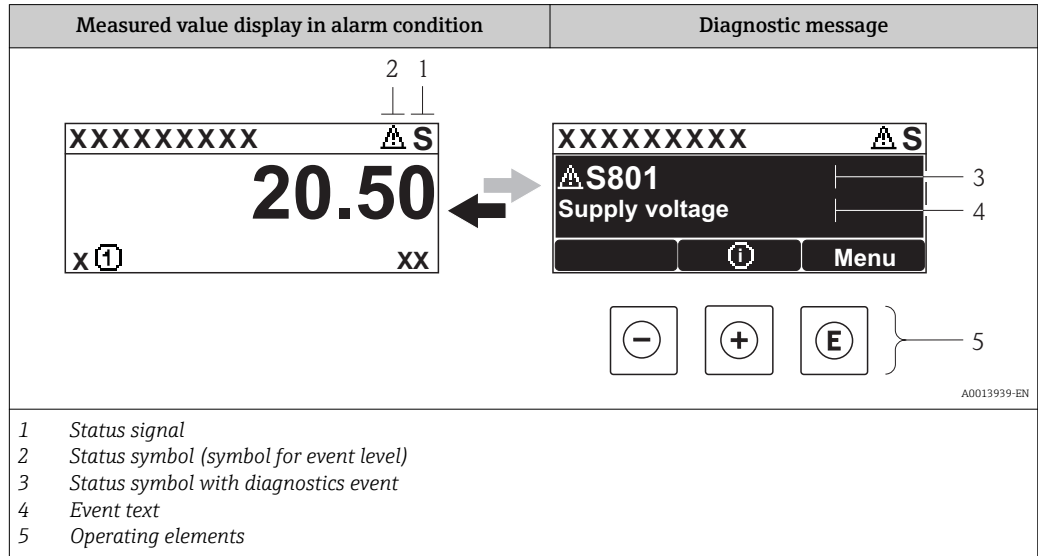

Status signals

F <small>A0013956</small>	"Failure" A device error is present. The measured value is no longer valid.
C <small>A0013959</small>	"Function check" The device is in service mode (e.g. during a simulation or a warning).
S <small>A0013958</small>	"Out of specification" The device is operated: <ul style="list-style-type: none"> ▪ Outside of its technical specifications (e.g. during startup or a cleaning) ▪ Outside of the configuration carried out by the user (e.g. level outside configured span)
M <small>A0013957</small>	"Maintenance required" Maintenance is required. The measured value is still valid.

Status symbol (symbol for event level)

 <small>A0013961</small>	"Alarm" status The measurement is interrupted. The signal outputs take on the defined alarm condition. A diagnostic message is generated.
 <small>A0013962</small>	"Warning" status The device continues to measure. A diagnostic message is generated.

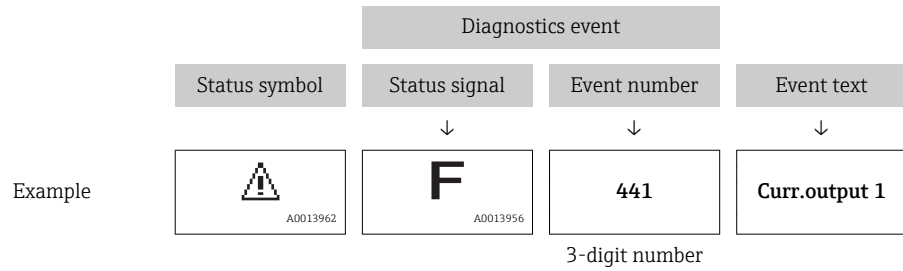

Diagnostics event and event text

The fault can be identified using the diagnostics event. The event text helps you by providing information about the fault. In addition, the corresponding symbol is displayed before the diagnostics event.



If two or more diagnostic messages are pending simultaneously, only the message with the highest priority is shown. Additional pending diagnostic messages can be shown in **Diagnostic list** submenu (→  239).

Operating elements

Operating functions in menu, submenu	
 <small>A0013970</small>	Plus key Opens the message about the remedial measures.
 <small>A0013952</small>	Enter key Opens the operating menu.

11.2.2 Calling up remedial measures

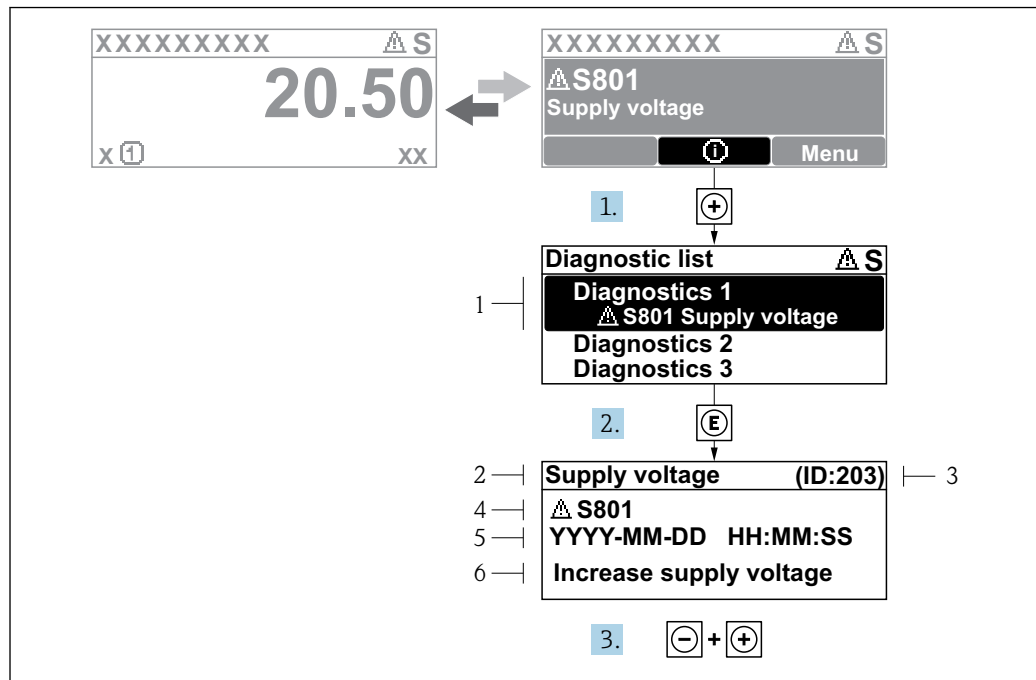

43 Message for remedial measures

- 1 Diagnostic information
- 2 Short text
- 3 Service ID
- 4 Diagnostic behavior with diagnostic code
- 5 Operation time of occurrence
- 6 Remedial measures

A diagnostic message appears in the standard view (measured value display).

1. Press \oplus (ⓘ symbol).
 - ↳ The **Diagnostic list** submenu opens.
2. Select the desired diagnostic event with \oplus or \ominus and press ⏏ .
 - ↳ The message for the remedial measures for the selected diagnostic event opens.
3. Press $\ominus + \oplus$ simultaneously.
 - ↳ The message for the remedial measures closes.

The user is in the **Diagnostics** menu at an entry for a diagnostics event, e.g. in the **Diagnostic list** submenu or in the **Previous diagnostics**.

1. Press ⏏ .
 - ↳ The message for the remedial measures for the selected diagnostic event opens.
2. Press $\ominus + \oplus$ simultaneously.
 - ↳ The message for the remedial measures closes.

11.3 Diagnostic information in FieldCare

Any faults detected by the measuring device are displayed on the home page of the operating tool once the connection has been established.

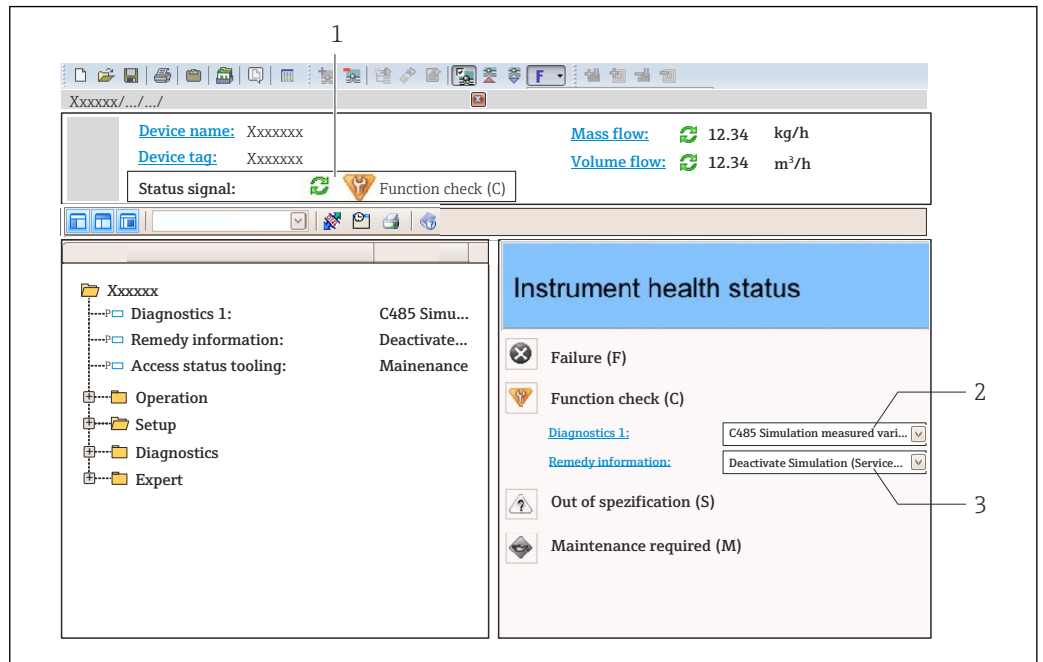

- 1 Status area with status signal
- 2 Diagnostic information
- 3 Remedial measures with Service ID

i Furthermore, diagnostic events that have occurred can be viewed in the **Diagnostic list** submenu.

11.3.1 Status signals

The status signals provide information on the state and reliability of the device by categorizing the cause of the diagnostic information (diagnostic event).

Symbol	Meaning
 <small>A0017271</small>	Failure A device error has occurred. The measured value is no longer valid.
 <small>A0017278</small>	Function check The device is in service mode (e.g. during a simulation or a warning).
 <small>A0017277</small>	Out of specification The device is operated outside its technical specification limits (e.g. outside the process temperature range)
 <small>A0017276</small>	Maintenance required Maintenance is required. The measured value is still valid.

i The status signals are categorized in accordance with VDI/VDE 2650 and NAMUR Recommendation NE 107.

11.3.2 Calling up remedy information

Remedy information is provided for every diagnostic event to ensure that problems can be rectified quickly:

- On the home page
Remedy information is displayed in a separate field below the diagnostics information.
- In the **Diagnostics** menu
Remedy information can be called up in the working area of the user interface.

The user is in the **Diagnostics** menu.

1. Call up the desired parameter.
2. On the right in the working area, mouse over the parameter.
 - ↳ A tool tip with remedy information for the diagnostic event appears.

11.4 Overview of the diagnostic messages

Diagnostic number	Short text	Remedy instructions	Status signal [from the factory]	Diagnostic behavior [from the factory]
Diagnostic of sensor				
102	Sensor incompatible error	1. Restart device 2. Contact service	F	Alarm
150	Detector error	1. Restart device 2. Check electrical connections of detector 3. Replace detector unit	F	Alarm
151	Sensor electronic failure	Replace sensor electronic module	F	Alarm
Diagnostic of electronic				
242	Software incompatible	1. Check software 2. Flash or change main electronics module	F	Alarm
252	Modules incompatible	1. Check if correct electronic modul is plugged 2. Replace electronic module	F	Alarm
261	Electronic modules	1. Restart device 2. Check electronic modules 3. Change I/O Modul or main electronics	F	Alarm
262	Module connection	1. Check module connections 2. Change electronic modules	F	Alarm
270	Main electronic failure	Replace main electronics	F	Alarm
271	Main electronic failure	1. Restart device 2. Change main electronic module	F	Alarm
272	Main electronic failure	1. Restart device 2. Contact service	F	Alarm
273	Main electronic failure	1. Emergency operation via display 2. Change main electronics	F	Alarm
275	I/O module failure	1. Restart device 2. Change I/O module	F	Alarm
276	I/O module faulty	1. Restart device 2. Change I/O module	F	Alarm
282	Data storage	1. Restart device 2. Contact service	F	Alarm
283	Memory content	1. Transfer data or reset device 2. Contact service	F	Alarm
284	Detector SW update in progress	Firmware update active, please wait!	F	Alarm
311	Electronic failure	Maintenance required! 1. Do not perform reset 2. Contact service	M	Warning
333	System recovery required	HW change detected System configuration recovery required Go to menu on device and perform recovery	F	Alarm
334	System recovery failure	HW changed, system recovery failure. Return to factory	F	Alarm

Diagnostic number	Short text	Remedy instructions	Status signal [from the factory]	Diagnostic behavior [from the factory]
381	Displacer distance invalid	1. Calibrate sensor 2. Restart device 3. Replace sensor electronics	F	Alarm
382	Sensor communication	1. Check connection of sensor electronics 2. Restart device 3. Replace sensor electronics	F	Alarm
Diagnostic of configuration				
400	AIO simulation output	Deactivate simulation AIO output	C	Warning
401	DIO simulation output	Deactivate simulation DIO output	C	Warning
403	Calibration AIO	1. Restart device 2. Change I/O module	F	Alarm
404	Calibration AIP	1. Restart device 2. Change I/O module	F	Alarm
405	COMM timeout DIO 1 to 8	1. Check wiring 2. Change I/O module	F	Alarm
406	IOM offline	1. Check wiring 2. Change I/O module	F	Alarm
407	COMM timeout AIO 1 to 2	1. Check wiring 2. Change I/O module	F	Alarm
408	Invalid range AIO 1 to 2	1. Check device configuration. 2. Check wiring.	C	Warning
409	RTD temp out of range 1 to 2	1. Check electronic modules 2. Change I/O or main electronic module	C	Warning
410	Data transfer	1. Check connection 2. Retry data transfer	F	Alarm
411	Hart device 1 to 15 has malfunction	1. Check HART device 2. Change HART device	F	Alarm ¹⁾
412	Processing download	Download active, please wait	C	Warning
413	NMT 1 to 15: element is open or short	1. Check NMT wiring connection 2. Replace NMT	C	Warning
415	Hart device 1 to 15 offline	1. Check HART device 2. Change HART device	C	Warning
434	Real time clock defective	Replace main electronics	C	Warning
436	Date/Time incorrect	Check date and time settings.	M	Warning
437	Configuration incompatible	1. Restart device 2. Contact service	F	Alarm
438	Dataset	1. Check data set file 2. Check device configuration 3. Up- and download new configuration	M	Warning
441	AIO 1 to 2 current output alarm	1. Check process 2. Check current output settings	F	Alarm
442	AIO 1 to 2 current output warning	1. Check process 2. Check current output settings	C	Warning
443	AIO 1 to 2 Input not HART compatible	Change PV source or AIO input source.	C	Warning
484	Failure mode simulation	Deactivate simulation	C	Alarm

Diagnostic number	Short text	Remedy instructions	Status signal [from the factory]	Diagnostic behavior [from the factory]
495	Diagnostic event simulation	Deactivate simulation	C	Warning
500	AIO C1-3 source no longer valid	Change input source	C	Warning
501	Level source no longer valid	Change input source	C	Warning
502	GP1 source no longer valid	Change input source	C	Warning
503	GP2 source no longer valid	Change input source	C	Warning
504	GP3 source no longer valid	Change input source	C	Warning
505	GP4 source no longer valid	Change input source	C	Warning
506	Water level source no longer valid	Change input source	C	Warning
507	Liquid temp source no longer valid	Change input source	C	Warning
508	Vapor temperatur source no longer valid	Change input source	C	Warning
509	Air temperature source no longer valid	Change input source	C	Warning
510	P1 source no longer valid	Change input source	C	Warning
511	P2 source no longer valid	Change input source	C	Warning
512	P3 source no longer valid	Change input source	C	Warning
513	Upper density source no longer valid	Change input source	C	Warning
514	Middle density source no longer valid	Change input source	C	Warning
515	Lower density source no longer valid	Change input source	C	Warning
516	Gauge command source no longer valid	Change input source	C	Warning
517	Gauge status source no longer valid	Change input source	C	Warning
518	Average density source no longer valid	Change input source	C	Warning
519	Upper interface source no longer valid	Change input source	C	Warning
520	Lower interface source no longer valid	Change input source	C	Warning
521	Bottom level source no longer valid	Change input source	C	Warning
522	Displacer position source not valid	Change input source	C	Warning
523	Distance source no longer valid	Change input source	C	Warning
524	Balance flag source no longer valid	Change input source	C	Warning
525	One time cmd source no longer valid	Change input source	C	Warning
526	Alarm 1 to 4 source no longer valid	Change input source	C	Warning

Diagnostic number	Short text	Remedy instructions	Status signal [from the factory]	Diagnostic behavior [from the factory]
527	AIO B1-3 source no longer valid	Change input source	C	Warning
528	CTSh	1. Check device configuration. 2. Check wiring.	C	Warning
529	HTG	1. Check device configuration. 2. Check wiring.	C	Warning
530	HTMS	1. Check device configuration. 2. Check wiring.	C	Warning
531	HyTD correction value	1. Check device configuration. 2. Check wiring.	C	Warning
532	HART output: PV source not valid	Change input source	C	Warning
533	HART output: SV source not valid	Change input source	C	Warning
534	HART output: QV source not valid	Change input source	C	Warning
535	HART output: TV source not valid	Change input source	C	Warning
536	Display: source no longer valid	Change input source	C	Warning
537	Trend: source no longer valid	Change input source	C	Warning
538	HART output: PV mA source not valid	Change input source	C	Warning
539	Modbus 1-4 SP source invalid	Set valid SP input selector	C	Warning
540	V1 1-4 SP source invalid	Set valid SP input selector	C	Warning
541	Modbus 1-4 alarm source invalid	Set valid alarm input selector	C	Warning
542	V1 1-4 alarm source invalid	Set valid alarm input selector	C	Warning
543	Modbus 1-4 analog source invalid	Set valid analog input selector	C	Warning
544	V1 1-4 analog source invalid	Set valid analog input selector	C	Warning
545	Modbus 1-4 user value source invalid	Set valid user value input selector	C	Warning
546	Modbus 1-4 discrete value source invalid	Set valid user discrete input selector	C	Warning
547	V1 1-4 user value source invalid	Set valid user value input selector	C	Warning
548	V1 1-4 discrete value source invalid	Set valid user discrete input selector	C	Warning
549	Modbus 1-4 percent source invalid	Set valid percentage input selector	C	Warning
550	V1 1-4 percent source invalid	Set valid percentage input selector	C	Warning
560	Calibration mandatory	1. Carry out weight calibration 2. Carry out reference calibration 3. Carry out drum calibration	C	Alarm
564	DIO B1-2 source no longer valid	Change input source	C	Warning
565	DIO B3-4 source not valid	Change input source	C	Warning

Diagnostic number	Short text	Remedy instructions	Status signal [from the factory]	Diagnostic behavior [from the factory]
566	DIO C1-2 source no longer valid	Change input source	C	Warning
567	DIO C3-4 source no longer valid	Change input source	C	Warning
568	DIO D1-2 source no longer valid	Change input source	C	Warning
569	DIO D3-4 source no longer valid	Change input source	C	Warning
585	Simulation distance	Deactivate simulation	C	Warning
586	Record map	Recording of mapping please wait	C	Warning
598	DIO A1-2 source no longer valid	Change input source	C	Warning
599	DIO A3-4 source no longer valid	Change input source	C	Warning
Diagnostic of process				
801	Energy too low	Increase supply voltage	S	Warning
803	Current loop	1. Check device configuration. 2. Check wiring.	F	Alarm
803	Current loop 1 to 2		M	Warning
803	Current loop		C	Warning
825	System temperature	1. Check ambient temperature 2. Check process temperature	S	Warning
825	System temperature		F	Alarm
826	Sensor temperature	1. Check ambient temperature 2. Check process temperature	S	Warning
826	Sensor temperature		F	Alarm
844	Process value out of specification	1. Check process value 2. Check application 3. Check sensor	S	Alarm ¹⁾
844	Process value out of specification		S	Warning
903	Current loop 1 to 2	1. Check device configuration. 2. Check wiring.	F	Alarm
904	Digital output 1 to 8	1. Check device configuration. 2. Check wiring.	F	Alarm
941	Echo lost	1. Check process value 2. Check application 3. Check sensor	S	Warning
942	In safety distance	1. Check level 2. Check safety distance 3. Reset self holding	S	Warning
943	In blocking distance	Reduced accuracy Check level	S	Warning
950	Advanced diagnostics	Maintain your diagnostic event	M	Warning
961	Alarm 1 to 4 HighHigh	1. Check alarm source 2. Check configuration settings	C	Warning
962	Alarm 1 to 4 High	1. Check alarm source 2. Check configuration settings	C	Warning
963	Alarm 1 to 4 Low	1. Check alarm source 2. Check configuration settings	C	Warning

Diagnostic number	Short text	Remedy instructions	Status signal [from the factory]	Diagnostic behavior [from the factory]
964	Alarm 1 to 4 LowLow	1. Check alarm source 2. Check configuration settings	C	Warning
965	Alarm 1 to 4 HighHigh	1. Check alarm source 2. Check configuration settings	F	Alarm
966	Alarm 1 to 4 High	1. Check alarm source 2. Check configuration settings	F	Alarm
967	Alarm 1 to 4 Low	1. Check alarm source 2. Check configuration settings	F	Alarm
968	Alarm 1 to 4 LowLow	1. Check alarm source 2. Check configuration settings	F	Alarm
970	Overtension	1. Check displacer and process conditions 2. Release overtension	C	Alarm
971	Undertension	Check displacer and process.	C	Alarm

- 1) Diagnostic behavior can be changed.



11.5 Diagnostic list

In the Diagnostic list submenu, up to 5 currently pending diagnostic messages can be displayed. If more than 5 messages are pending, the messages with the highest priority are shown on the display.

Navigation path

Diagnostics → Diagnostic list

Calling up and closing the remedial measures

1. Press .
 - ↳ The message for the remedial measures for the selected diagnostic event opens.
2. Press  +  simultaneously.
 - ↳ The message about the remedial measures closes.

11.6 Reset measuring device

To reset the device to a defined state use the **Device reset** parameter (→  235).

11.7 Device information

Information on the device (order code, hardware and software version of the individual modules etc.) can be found in the **Device information** submenu (→  240).

11.8 Firmware history

Date	Software version	Modifications	Documentation (NRF81)		
			Operating Instructions	Description of Parameters	Technical Information
04.2016	01.00.zz	Original software	BA01465G/00/EN/01.16	GP01083G/00/EN/01.16	TI01251G/00/EN/01.16
12.2016	01.02.zz	Bugfixes and improvements	BA01465G/00/EN/02.17	GP01083G/00/EN/01.17	TI01251G/00/EN/02.17

12 Maintenance

12.1 Maintenance tasks

No special maintenance work is required.

12.1.1 Exterior cleaning

When cleaning the exterior of measuring devices, always use cleaning agents that do not attack the surface of the housing or the seals.

12.2 Endress+Hauser services

Endress+Hauser offers a wide variety of services for maintenance such as recalibration, maintenance service or device tests.



Your Endress+Hauser Sales Center can provide detailed information on the services.

13 Repair

13.1 General information on repairs

13.1.1 Repair concept

The Endress+Hauser repair concept assumes that the devices have a modular design and that repairs can be done by the Endress+Hauser service or specially trained customers.

Spare parts are contained in suitable kits. They contain the related replacement instructions.

For more information on service and spare parts, contact the Service Department at Endress+Hauser.

13.1.2 Repairs to Ex-approved devices

When carrying out repairs to Ex-approved devices, please note the following:

- Repairs to Ex-approved devices may only be carried out by trained personnel or by the Endress+Hauser Service.
- Comply with the prevailing standards, national Ex-area regulations, safety instructions (XA) and certificates.
- Only use original spare parts from Endress+Hauser.
- When ordering a spare part, please note the device designation on the nameplate. Only replace parts with identical parts.
- Carry out repairs according to the instructions. On completion of repairs, carry out the specified routine test on the device.
- Only Endress+Hauser Service may convert a certified device into a different certified variant.
- Document all repair work and conversions.

13.1.3 Replacement of a device or electronic module

After a complete device or the electronic mainboard has been replaced, the parameters can be downloaded into the instrument again via FieldCare.

Condition: The configuration of the old device has been saved to the computer via FieldCare.

The "Save/Restore" function

After a device configuration has been saved to a computer and restored to the device using the **Save/Restore** function of FieldCare, the device must be restarted by the following setting:

Setup → **Advanced setup** → **Administration** → **Device reset** = **Restart device**.

This ensures correct operation of the device after the restore.

13.2 Spare parts

Some interchangeable measuring device components are listed on an overview sign in the connection compartment cover.

The spare part overview sign contains the following information:

- A list of the most important spare parts for the measuring device, including their ordering information.
- The URL for the *W@M Device Viewer* (www.endress.com/deviceviewer):
All the spare parts for the measuring device, along with the order code, are listed here and can be ordered. If available, users can also download the associated Installation Instructions.

13.3 Endress+Hauser services

Endress+Hauser offers a wide range of services.

 Your Endress+Hauser Sales Center can provide detailed information on the services.

13.4 Return

The measuring device must be returned if it is need of repair or a factory calibration, or if the wrong measuring device has been delivered or ordered. Legal specifications require Endress+Hauser, as an ISO-certified company, to follow certain procedures when handling products that are in contact with the medium.

To ensure safe, swift and professional device returns, please refer to the procedure and conditions for returning devices provided on the Endress+Hauser website at <http://www.endress.com/support/return-material>

13.5 Disposal

Observe the following notes during disposal:

- Observe valid federal/national regulations.
- Ensure proper separation and reuse of the device components.

14 Accessories

14.1 Device-specific accessories

14.1.1 Weather protection cover

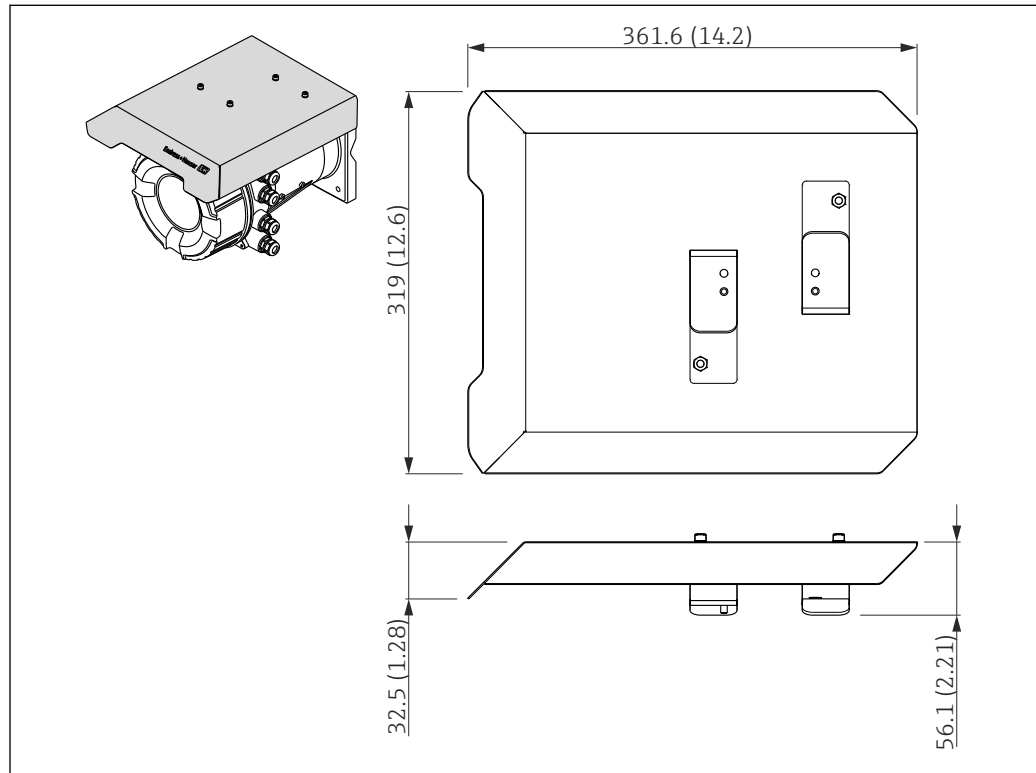

44 Weather protection cover; dimensions: mm (in)

Materials

Part	Material
Protection cover and mounting brackets	316L (1.4404)
Screws and washers	A4

- i** The weather protection cover can be ordered together with the device:
Ordering feature 620 "Accessory Enclosed", option PA "Weather Protection Cover")
- It can also be ordered as an accessory:
Order code: 71292751 (for NMR8x and NRF8x)

14.2 Communication-specific accessories

Accessory	Description
WirelessHART Adapter SWA70	<p>Connects field devices to a WirelessHART network. The WirelessHART adapter can be mounted directly at a HART device and is easily integrated into an existing HART network. It ensures safe data transmission and can be operated in parallel with other wireless networks.</p> <p> For details refer to Operating Instructions BA00061S</p>



14.3 Service-specific accessories

Accessory	Description
Commubox FXA195 HART	<p>For intrinsically safe HART communication with FieldCare via the USB interface.</p> <p> For details refer to Technical Information TI00404F</p>





Accessory	Description
Commubox FXA291	<p>Connects Endress+Hauser field devices with CDI interface (= Endress+Hauser Common Data Interface) to the USB interface of a computer.</p> <p> For details refer to Technical Information TI00405C</p>

Accessory	Description
FieldCare	<p>Endress+Hauser's FDT-based Plant Asset Management tool. Helps to configure and maintain all field devices of your plant. By supplying status information it also supports the diagnosis of the devices.</p> <p> For details refer to Operating Instructions BA00027S and BA00059S.</p>





14.4 System components

Accessory	Description
RIA15	<p>Compact process display unit with very low voltage drop for universal use to display 4 to 20 mA/HART signals</p> <p> For details refer to Technical Information TI01043K.</p>
Tankvision <ul style="list-style-type: none"> ▪ Tank Scanner NXA820 ▪ Data Concentrator NXA821 ▪ Host Link NXA822 	<p>Inventory Management System with completely integrated software for operation via standard web browser</p> <p> For details refer to Technical Information TI00419G.</p>













15 Operating menu



























-   : Navigation path for operating module at the device
-  : Navigation path for operating tool (e.g. FieldCare)
-  : Parameter can be locked via software locking

























15.1 Overview of the operating menu























-  This section lists the parameters of the following menus:
 - Operation (→  112)
 - Setup (→  121)
 - Diagnostics (→  236)
- For the **Expert** menu refer to the "Description of Device Parameters" (GP) of the respective device.
- Depending on the device version and parametrization some parameters will not be available in a given situation. For details refer to the "Prerequisite" category in the description of the respective parameter.
- The representation essentially corresponds to the menu in an operating tool (e.g. FieldCare). On the local display there may be minor differences in the menu structure. Details are mentioned in the description of the respective submenu.

Navigation   Operating tool

Operation	→  112
▶ Level	→  112
Tank level	→  112
Tank Level %	→  112
Tank ullage	→  112
Tank ullage %	→  113
Upper interface level	→  113
Lower interface level	→  113
Water level	→  113
Measured level	→  114
▶ Temperature	→  114
Air temperature	→  114
Liquid temperature	→  114

























Vapor temperature	→  114
▶ NMT element values	→  115
▶ Element temperature	→  115
Element temperature 1 to 24	→  115
▶ Element position	→  115
Element position 1 to 24	→  115
▶ Density	→  116
Observed density	→  116
Vapor density	→  116
Air density	→  116
Measured upper density	→  117
Measured middle density	→  117
Measured lower density	→  117
▶ Pressure	→  118
P1 (bottom)	→  118
P2 (middle)	→  118
P3 (top)	→  118
▶ GP values	→  119
GP 1 to 4 name	→  119
GP Value 1	→  119
GP Value 2	→  119
GP Value 3	→  119
GP Value 4	→  120
 Setup	→  121
Device tag	→  121

Units preset	→  121
Tank reference height	→  122
Tank level	→  112
Level source	→  122
Liquid temp source	→  123
▶ Advanced setup	→  124
Locking status	→  124
Access status tooling	→  124
Enter access code	→  124
▶ Input/output	→  125
▶ HART devices	→  125
Number of devices	→  125
▶ HART Device(s)	→  126
▶ Forget device	→  131
▶ Analog IP	→  132
Operating mode	→  132
RTD type	→  132
RTD connection type	→  133
Process value	→  133
Process variable	→  134
0 % value	→  134
100 % value	→  134
Input value	→  135
Minimum probe temperature	→  135
Maximum probe temperature	→  135

Probe position	→  136
Damping factor	→  136
Gauge current	→  137
► Analog I/O	→  138
Operating mode	→  138
Current span	→  139
Fixed current	→  140
Analog input source	→  140
Failure mode	→  141
Error value	→  142
Input value	→  142
0 % value	→  142
100 % value	→  143
Input value %	→  143
Output values	→  143
Process variable	→  144
Analog input 0% value	→  144
Analog input 100% value	→  144
Error event type	→  145
Process value	→  145
Input value in mA	→  145
Input value percent	→  146
Damping factor	→  146

Used for SIL/WHG	→ 146
Expected SIL/WHG chain	→ 147
▶ Digital Xx-x	→ 148
Operating mode	→ 148
Digital input source	→ 149
Input value	→ 150
Contact type	→ 150
Output simulation	→ 150
Output values	→ 151
Readback value	→ 151
Used for SIL/WHG	→ 152
▶ Communication	→ 153
▶ Communication interface 1 to 2	
Communication interface protocol	→ 153
▶ Configuration	→ 154
▶ Configuration	→ 157
▶ V1 input selector	→ 160
▶ HART output	→ 162
▶ Configuration	→ 162
▶ Information	→ 170
▶ Application	→ 172
▶ Tank configuration	→ 172
▶ Level	→ 172
▶ Temperature	→ 175

▶ Density	→ 📄 179
▶ Pressure	→ 📄 181
▶ Tank calculation	→ 📄 188
▶ HyTD	→ 📄 190
▶ CTSh	→ 📄 195
▶ HTG	→ 📄 205
▶ HTMS	→ 📄 210
▶ Alarm	
▶ Alarm 1 to 4	→ 📄 214
▶ Display	→ 📄 222
Language	→ 📄 222
Format display	→ 📄 222
Value 1 to 4 display	→ 📄 223
Decimal places 1 to 4	→ 📄 224
Separator	→ 📄 224
Number format	→ 📄 225
Header	→ 📄 225
Header text	→ 📄 225
Display interval	→ 📄 226
Display damping	→ 📄 226
Backlight	→ 📄 226
Contrast display	→ 📄 227
▶ System units	→ 📄 228
Units preset	→ 📄 121
Distance unit	→ 📄 228

Pressure unit	→  229
Temperature unit	→  229
Density unit	→  229
► Date / time	→  231
Date/time	→  231
Set date	→  231
Year	→  231
Month	→  232
Day	→  232
Hour	→  232
Minute	→  233
► SIL confirmation	→  234
► Deactivate SIL/WHG	→  234
► Administration	→  235
Define access code	→  235
Device reset	→  235
 Diagnostics	→  236
Actual diagnostics	→  236
Timestamp	→  236
Previous diagnostics	→  236
Timestamp	→  237
Operating time from restart	→  237
Operating time	→  237
Date/time	→  231

▶ Diagnostic list	→ 📄 239
Diagnostics 1 to 5	→ 📄 239
Timestamp 1 to 5	→ 📄 239
▶ Device information	→ 📄 240
Device tag	→ 📄 240
Serial number	→ 📄 240
Firmware version	→ 📄 240
Firmware CRC	→ 📄 240
Weight and measures configuration CRC	→ 📄 241
Device name	→ 📄 241
Order code	→ 📄 241
Extended order code 1 to 3	→ 📄 241
▶ Simulation	→ 📄 243
Device alarm simulation	→ 📄 243
Diagnostic event simulation	→ 📄 243
Current output 1 simulation	→ 📄 243
Simulation value	→ 📄 244

15.2 "Operation" menu

The **Operation** menu (→  112) shows the most important measured values.

Navigation   Operation

15.2.1 "Level" submenu

Navigation   Operation → Level

Tank level

Navigation   Operation → Level → Tank level

Description Shows the distance from the zero position (tank bottom or datum plate) to the product surface.

Additional information

Read access	Operator
Write access	-

Tank Level %

Navigation   Operation → Level → Tank Level %

Description Shows the level as a percentage of the full measuring range.

Additional information

Read access	Operator
Write access	-

Tank ullage

Navigation   Operation → Level → Tank ullage

Description Shows the remaining empty space in the tank.

Additional information

Read access	Operator
Write access	-

Tank ullage %

Navigation
 Operation → Level → Tank ullage %
Description

Shows the remaining empty space in percentage related to parameter tank reference height.

Additional information

Read access	Operator
Write access	-

Upper interface level

Navigation
 Operation → Level → Upper interface level
Description

Shows measured interface level from zero position (tank bottom or datum plate). Value is updated when device generates a valid Interface measurement.

Additional information

Read access	Maintenance
Write access	-

Lower interface level

Navigation
 Operation → Level → Lower interface level
Description

Shows measured interface level from zero position (tank bottom or datum plate). Value is updated when device generates a valid interface measurement.

Additional information

Read access	Maintenance
Write access	-

Water level

Navigation
 Operation → Level → Water level
Description

Shows the bottom water level.

Additional information

Read access	Operator
Write access	-

Measured level

Navigation  Operation → Level → Measured level**Description** Shows the measured level without any correction from the tank calculations.**Additional information**

Read access	Operator
Write access	-

15.2.2 "Temperature" submenu

Navigation  Operation → Temperature

Air temperature

Navigation  Operation → Temperature → Air temperature**Description** Shows the air temperature.**Additional information**

Read access	Operator
Write access	-

Liquid temperature

Navigation  Operation → Temperature → Liquid temperature**Description** Shows the average or spot temperature of the measured liquid.**Additional information**

Read access	Operator
Write access	-

Vapor temperature

Navigation  Operation → Temperature → Vapor temperature**Description** Shows the measured vapor temperature.

Additional information

Read access	Operator
Write access	-

"NMT element values" submenu

 This submenu is only visible if a Prothermo NMT is connected.

Navigation  Operation → Temperature → NMT element values

"Element temperature" submenu

Navigation  Operation → Temperature → NMT element values → Element temperature

Element temperature 1 to 24

Navigation

 Operation → Temperature → NMT element values → Element temperature → Element temperature 1 to 24

Description

Shows the temperature of an element in the NMT.

Additional information

Read access	Operator
Write access	-

"Element position" submenu

Navigation  Operation → Temperature → NMT element values → Element position

Element position 1 to 24

Navigation

 Operation → Temperature → NMT element values → Element position → Element position 1 to 24

Description

Shows the position of the selected element in the NMT.

Additional information

Read access	Operator
Write access	-

15.2.3 "Density" submenu

Navigation  Operation → Density

Observed density**Navigation**



 Operation → Density → Observed density

Description

Calculated density of the product.

Additional information

Read access	Operator
Write access	-

 This value is calculated from different measured variables depending on the selected calculation method →  188.

Vapor density**Navigation**

 Operation → Density → Vapor density

Description

Defines the density of the gas phase in the tank.

User entry

0.0 to 500.0 kg/m³

Factory setting

1.2 kg/m³

Additional information

Read access	Operator
Write access	Maintenance

Air density**Navigation**

 Operation → Density → Air density

Description

Defines the density of the air surrounding the tank.

User entry

0.0 to 500.0 kg/m³

Factory setting 1.2 kg/m³

Additional information

Read access	Operator
Write access	Maintenance

Measured upper density

Navigation  Operation → Density → Measured upper density

Description Shows the density of the upper phase.

Additional information

Read access	Operator
Write access	-

Measured middle density

Navigation  Operation → Density → Measured middle density

Description Density of the middle phase.

Additional information

Read access	Operator
Write access	-

Measured lower density

Navigation  Operation → Density → Measured lower density

Description Density of the lower phase.

Additional information

Read access	Maintenance
Write access	-

15.2.4 "Pressure" submenu

Navigation  Operation → Pressure

P1 (bottom)

Navigation  Operation → Pressure → P1 (bottom)

Description Shows the pressure at the tank bottom.

Additional information

Read access	Operator
Write access	-

P2 (middle)

Navigation  Operation → Pressure → P2 (middle)

Description Shows the pressure (P2) at the middle transmitter.

Additional information

Read access	Operator
Write access	-

P3 (top)

Navigation  Operation → Pressure → P3 (top)

Description Shows the pressure (P3) at the top transmitter.

Additional information

Read access	Operator
Write access	-

15.2.5 "GP values" submenu

Navigation  Operation → GP values

GP 1 to 4 name

Navigation  Operation → GP values → GP 1 name

Description Defines the label associated with the respective GP value.

Factory setting GP Value 1

Additional information

Read access	Operator
Write access	Maintenance

GP Value 1

Navigation  Operation → GP values → GP Value 1

Description Displays the value that will be used as general purpose value.

Additional information

Read access	Operator
Write access	-

GP Value 2

Navigation  Operation → GP values → GP Value 2

Description Displays the value that will be used as general purpose value.

Additional information

Read access	Operator
Write access	-

GP Value 3

Navigation  Operation → GP values → GP Value 3

Description Displays the value that will be used as general purpose value.

Additional information

Read access	Operator
Write access	-

GP Value 4

Navigation Operation → GP values → GP Value 4**Description**





Displays the value that will be used as general purpose value.



Additional information

Read access	Operator
Write access	-





15.3 "Setup" menu

Navigation   Setup

Device tag 					
Navigation	  Setup → Device tag				
Description	Enter a unique name for the measuring point to identify the device quickly within the plant.				
Factory setting	NRF8x				
Additional information	<table border="1"> <tr> <td>Read access</td> <td>Operator</td> </tr> <tr> <td>Write access</td> <td>Maintenance</td> </tr> </table>	Read access	Operator	Write access	Maintenance
Read access	Operator				
Write access	Maintenance				
Units preset 					

Navigation	  Setup → Units preset				
Description	Defines a set of units for length, pressure and temperature.				
Selection	<ul style="list-style-type: none"> ■ mm, bar, °C ■ m, bar, °C ■ mm, PSI, °C ■ ft, PSI, °F ■ ft-in-16, PSI, °F ■ ft-in-8, PSI, °F ■ Customer value 				
Factory setting	mm, bar, °C				
Additional information	<table border="1"> <tr> <td>Read access</td> <td>Operator</td> </tr> <tr> <td>Write access</td> <td>Maintenance</td> </tr> </table>	Read access	Operator	Write access	Maintenance
Read access	Operator				
Write access	Maintenance				

If the **Customer value** option is selected, the units are defined in the following parameters:

- Distance unit (→  228)
- Pressure unit (→  229)
- Temperature unit (→  229)
- Density unit (→  229)

In any other case these are read-only parameters used to indicate the respective unit.

Tank reference height



Navigation	Setup → Tank reference height				
Description	Defines the distance from the dipping reference point to the zero position (tank bottom or datum plate).				
User entry	0 to 10 000.00 mm				
Factory setting	Dependent on the device version				
Additional information	<table border="1" style="width: 100%; border-collapse: collapse;"> <tr> <td style="width: 50%;">Read access</td> <td>Operator</td> </tr> <tr> <td>Write access</td> <td>Maintenance</td> </tr> </table>	Read access	Operator	Write access	Maintenance
Read access	Operator				
Write access	Maintenance				

Tank level

Navigation	Setup → Tank level				
Description	Shows the distance from the zero position (tank bottom or datum plate) to the product surface.				
Additional information	<table border="1" style="width: 100%; border-collapse: collapse;"> <tr> <td style="width: 50%;">Read access</td> <td>Operator</td> </tr> <tr> <td>Write access</td> <td>-</td> </tr> </table>	Read access	Operator	Write access	-
Read access	Operator				
Write access	-				

Level source



Navigation	Setup → Level source				
Description	Defines the source of the level value.				
Selection	<ul style="list-style-type: none"> ■ No input value ■ HART device 1 ... 15 level ■ Level SR[*] ■ Level[*] ■ Displacer position[*] ■ AIO B1-3 value[*] ■ AIO C1-3 value[*] ■ AIP B4-8 value[*] ■ AIP C4-8 value[*] 				
Factory setting	Dependent on the device version				
Additional information	<table border="1" style="width: 100%; border-collapse: collapse;"> <tr> <td style="width: 50%;">Read access</td> <td>Operator</td> </tr> <tr> <td>Write access</td> <td>Maintenance</td> </tr> </table>	Read access	Operator	Write access	Maintenance
Read access	Operator				
Write access	Maintenance				

* Visibility depends on order options or device settings

Liquid temp source



Navigation Setup → Liquid temp source

Description Defines source from which the liquid temperature is obtained.

- Selection**
- Manual value
 - HART device 1 ... 15 temperature
 - AIO B1-3 value
 - AIO C1-3 value
 - AIP B4-8 value
 - AIP C4-8 value

Factory setting Manual value

Additional information

Read access	Operator
Write access	Maintenance

15.3.1 "Advanced setup" submenu

Navigation  Setup → Advanced setup

Locking status

Navigation  Setup → Advanced setup → Locking status

Description Indicates the write protection with the highest priority that is currently active.

Additional information

Read access	Operator
Write access	-

Access status tooling

Navigation  Setup → Advanced setup → Access status tooling

Description Shows the access authorization to the parameters via the operating tool.

Additional information

Read access	Operator
Write access	-

Enter access code

Navigation  Setup → Advanced setup → Enter access code

Description Enter access code to disable write protection of parameters.

Additional information

Read access	Operator
Write access	Operator

"Input/output" submenu

Navigation  Setup → Advanced setup → Input/output

"HART devices" submenu

Navigation  Setup → Advanced setup → Input/output → HART devices

Number of devices

Navigation  Setup → Advanced setup → Input/output → HART devices → Number of devices

Description Shows the number of devices on the HART bus.

Additional information

Read access	Operator
Write access	-

"HART Device(s)" submenu

 There is a **HART Device(s)** submenu for each HART slave device found on the HART loop.

Navigation  Setup → Advanced setup → Input/output → HART devices → HART Device(s)

Device name

Navigation

 Setup → Advanced setup → Input/output → HART devices → HART Device(s) → Device name

Description

Shows the name of the transmitter.

Additional information

Read access	Operator
Write access	-

Polling address

Navigation

 Setup → Advanced setup → Input/output → HART devices → HART Device(s) → Polling address

Description

Shows the polling address of the transmitter.

Additional information

Read access	Operator
Write access	-

Device tag

Navigation

 Setup → Advanced setup → Input/output → HART devices → HART Device(s) → Device tag

Description

Shows the device tag of the transmitter.

Additional information

Read access	Operator
Write access	-

Operating mode



Navigation Setup → Advanced setup → Input/output → HART devices → HART Device(s) → Operating mode

Prerequisite Not available if the HART device is a Prothermo NMT.

Description Selection of the operation mode PV only or PV,SV,TV,QV. Devines which values are polled from the connected HART Device.

- Selection**
- PV only
 - PV,SV,TV & QV
 - Level ⁴⁾
 - Measured level ⁴⁾

Factory setting PV,SV,TV & QV

Additional information

Read access	Operator
Write access	Maintenance

Communication status

Navigation Setup → Advanced setup → Input/output → HART devices → HART Device(s) → Communication status

Description Shows the operating status of the transmitter.

- User interface**
- Operating normally
 - Device offline

Additional information

Read access	Operator
Write access	-

#blank# (HART PV - designation dependent on device)

Navigation Setup → Advanced setup → Input/output → HART devices → HART Device(s) → #blank#



Description Shows the first HART variable (PV).

Additional information

Read access	Operator
Write access	-

4) only visible if the connected device is a Micropilot



#blank# (HART SV - designation dependent on device)

- Navigation**  Setup → Advanced setup → Input/output → HART devices → HART Device(s) → #blank#
- Prerequisite** For HART devices other than NMT: **Operating mode** (→  127) = **PV,SV,TV & QV**
- Description** Shows the second HART variable (SV).

Additional information

Read access	Operator
Write access	-



#blank# (HART TV - designation dependent on device)

- Navigation**  Setup → Advanced setup → Input/output → HART devices → HART Device(s) → #blank#
- Prerequisite** For HART devices other than NMT: **Operating mode** (→  127) = **PV,SV,TV & QV**
- Description** Shows the third HART variable (TV).

Additional information

Read access	Operator
Write access	-

#blank# (HART QV - designation dependent on device)

- Navigation**  Setup → Advanced setup → Input/output → HART devices → HART Device(s) → #blank#
- Prerequisite** For HART devices other than NMT: **Operating mode** (→  127) = **PV,SV,TV & QV**
- Description** Shows the fourth HART variable (QV).

Additional information

Read access	Operator
Write access	-

Output pressure 

- Navigation**  Setup → Advanced setup → Input/output → HART devices → HART Device(s) → Output pressure
- Prerequisite** Not available for Micropilot S FMR5xx and Prothermo 53x. (In these cases the measured variables are allocated automatically).

Description Defines which HART variable is the pressure.

Selection



- No value
- Primary variable (PV)
- Secondary variable (SV)
- Tertiary variable (TV)
- Quaternary variable (QV)

Factory setting No value

Additional information

Read access	Operator
Write access	Maintenance

Output density

Navigation   Setup → Advanced setup → Input/output → HART devices → HART Device(s) → Output density

Prerequisite Not available for Micropilot S FMR5xx and Prothermo 53x. (In these cases the measured variables are allocated automatically).

Description Defines which HART variable is the density.

Selection



- No value
- Primary variable (PV)
- Secondary variable (SV)
- Tertiary variable (TV)
- Quaternary variable (QV)

Factory setting No value

Additional information

Read access	Operator
Write access	Maintenance

Output temperature

Navigation   Setup → Advanced setup → Input/output → HART devices → HART Device(s) → Output temperature

Prerequisite Not available for Micropilot S FMR5xx and Prothermo 53x. (In these cases the measured variables are allocated automatically).

Description Defines which HART variable is the temperature.

Selection

- No value
- Primary variable (PV)
- Secondary variable (SV)
- Tertiary variable (TV)
- Quaternary variable (QV)



Factory setting No value

Additional information

Read access	Operator
Write access	Maintenance

Output vapor temperature 

Navigation

  Setup → Advanced setup → Input/output → HART devices → HART Device(s)
→ Output vapor temperature

Prerequisite

Not available for Micropilot S FMR5xx and Prothermo 53x. (In these cases the measured variables are allocated automatically).

Description

Defines which HART variable is the vapor temperature.

Selection

- No value
- Primary variable (PV)
- Secondary variable (SV)
- Tertiary variable (TV)
- Quaternary variable (QV)

Factory setting



No value

Additional information

Read access	Operator
Write access	Maintenance

Output level 

Navigation

  Setup → Advanced setup → Input/output → HART devices → HART Device(s)
→ Output level

Prerequisite

Not available for Micropilot S FMR5xx and Prothermo 53x. (In these cases the measured variables are allocated automatically).

Description

Defines which HART variable is the level.

Selection

- No value
- Primary variable (PV)
- Secondary variable (SV)
- Tertiary variable (TV)
- Quaternary variable (QV)

Factory setting



No value



Additional information

Read access	Operator
Write access	Maintenance

"Forget device" wizard



Read access	Maintenance
-------------	-------------

 This submenu is only visible if **Number of devices** (→  125) ≥ 1.

Navigation   Setup → Advanced setup → Input/output → HART devices
→ Forget device

Forget device



Navigation   Setup → Advanced setup → Input/output → HART devices → Forget device → Forget device

Description With this function an offline device can be deleted from the device list.

Selection

- HART Device 1 *
- HART Device 2 *
- HART Device 3 *
- HART Device 4 *
- HART Device 5 *
- HART Device 6 *
- HART Device 7 *
- HART Device 8 *
- HART Device 9 *
- HART Device 10 *
- HART Device 11 *
- HART Device 12 *
- HART Device 13 *
- HART Device 14 *
- HART Device 15 *
- None

Factory setting None

Additional information

Read access	Operator
Write access	Maintenance

* Visibility depends on order options or device settings

"Analog IP" submenu

i There is a **Analog IP** submenu for each Analog I/O module of the device. This submenu refers to terminals 4 to 8 of this module (the analog input). They are primarily used to connect an RTD. For terminals 1 to 3 (analog input or output) refer to → 138.

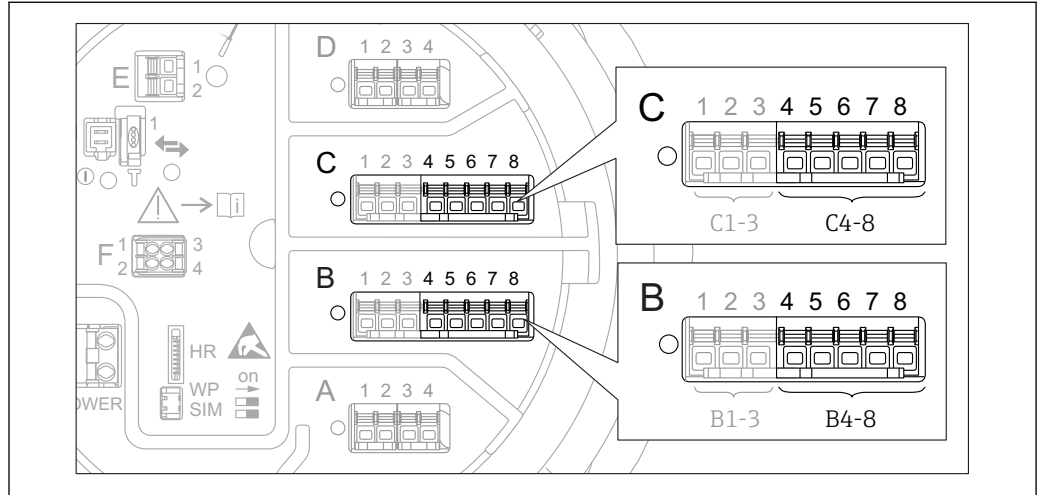

45 Terminals for the "Analog IP" submenu ("B4-8" or "C4-8", respectively)

Navigation Setup → Advanced setup → Input/output → Analog IP

Operating mode

Navigation Setup → Advanced setup → Input/output → Analog IP → Operating mode

Description Defines the operating mode of the analog input.

- Selection
- Disabled
 - RTD temperature input
 - Gauge power supply

Factory setting Disabled

Additional information

Read access	Operator
Write access	Maintenance

RTD type

Navigation Setup → Advanced setup → Input/output → Analog IP → RTD type

Prerequisite **Operating mode** (→ 132) = RTD temperature input

Description Defines the type of the connected RTD.

- Selection**
- Cu50 (w=1.428, GOST)
 - Cu53 (w=1.426, GOST)
 - Cu90; 0°C (w=1.4274, GOST)
 - Cu100; 25°C (w=1.4274, GOST)
 - Cu100; 0°C(w=1.4274, GOST)
 - Pt46 (w=1.391, GOST)
 - Pt50 (w=1.391, GOST)
 - Pt100(385) (a=0.00385, IEC751)
 - Pt100(389) (a=0.00389, Canadian)
 - Pt100(391) (a=0.003916, JIS1604)
 - Pt100 (w=1.391, GOST)
 - Pt500(385) (a=0.00385, IEC751)
 - Pt1000(385) (a=0.00385, IEC751)
 - Ni100(617) (a=0.00617, DIN43760)
 - Ni120(672) (a=0.00672, DIN43760)
 - Ni1000(617) (a=0.00617, DIN43760)

Factory setting Pt100(385) (a=0.00385, IEC751)

Additional information

Read access	Operator
Write access	Maintenance

RTD connection type



Navigation Setup → Advanced setup → Input/output → Analog IP → RTD connection type

Prerequisite **Operating mode (→ 132) = RTD temperature input**

Description Defines the connection type of the RTD.

- Selection**
- 4 wire RTD connection
 - 2 wire RTD connection
 - 3 wire RTD connection

Factory setting 4 wire RTD connection

Additional information

Read access	Operator
Write access	Maintenance

Process value

Navigation Setup → Advanced setup → Input/output → Analog IP → Process value

Prerequisite **Operating mode (→ 132) ≠ Disabled**

Description Shows the measured value received via the analog input.

Additional information

Read access	Operator
Write access	-

Process variable



Navigation Setup → Advanced setup → Input/output → Analog IP → Process variable

Prerequisite **Operating mode (→ 132) ≠ RTD temperature input**

Description Determines type of measured value.

- Selection**
- Level linearized
 - Temperature
 - Pressure
 - Density

Factory setting Level linearized

Additional information

Read access	Operator
Write access	Maintenance

0 % value



Navigation Setup → Advanced setup → Input/output → Analog IP → 0 % value

Prerequisite **Operating mode (→ 132) = 4..20mA input**

Description Defines the value represented by a current of 4mA.

User entry -100 000 to 100 000 mm

Factory setting 0 mm

Additional information

Read access	Operator
Write access	Maintenance

100 % value



Navigation Setup → Advanced setup → Input/output → Analog IP → 100 % value

Prerequisite **Operating mode (→ 132) = 4..20mA input**

Description Defines the value represented by a current of 20mA.



User entry -100 000 to 100 000 mm

Factory setting 0 mm

Additional information

Read access	Operator
Write access	Maintenance

Input value

Navigation   Setup → Advanced setup → Input/output → Analog IP → Input value

Prerequisite **Operating mode (→  132) ≠ Disabled**



Description Shows the value received via the analog input.

Additional information

Read access	Operator
Write access	-

Minimum probe temperature



Navigation   Setup → Advanced setup → Input/output → Analog IP → Minimum probe temperature

Prerequisite **Operating mode (→  132) = RTD temperature input**

Description Minimum approved temperature of the connected probe. If the temperature falls below this value, the W&M status will be 'invalid'.

User entry -213 to 927 °C



Factory setting -100 °C

Additional information

Read access	Operator
Write access	Maintenance

Maximum probe temperature



Navigation   Setup → Advanced setup → Input/output → Analog IP → Maximum probe temperature

Prerequisite **Operating mode (→  132) = RTD temperature input**

Description Maximum approved temperature of the connected probe. If the temperature rises above this value, the W&M status will be 'invalid'.



User entry -213 to 927 °C

Factory setting 250 °C

Additional information

Read access	Operator
Write access	Maintenance

Probe position 

Navigation   Setup → Advanced setup → Input/output → Analog IP → Probe position

Prerequisite **Operating mode (→  132) = RTD temperature input**

Description Position of the temperature probe, measured from zero position (tank bottom or datum plate). This parameter, in conjunction with the measured level, determines whether the temperature probe is still covered by the product. If this is no longer the case, the status of the temperature value will be 'invalid'.

User entry -5 000 to 30 000 mm

Factory setting 5 000 mm

Additional information

Read access	Operator
Write access	Maintenance

Damping factor 

Navigation   Setup → Advanced setup → Input/output → Analog IP → Damping factor

Prerequisite **Operating mode (→  132) ≠ Disabled**

Description Defines the damping constant (in seconds).



User entry 0 to 999.9 s

Factory setting 0 s

Additional information

Read access	Operator
Write access	Maintenance

Gauge current

Navigation Setup → Advanced setup → Input/output → Analog IP → Gauge current**Prerequisite****Operating mode (→  132) = Gauge power supply****Description**

Shows the current on the power supply line for the connected device.

Additional information

Read access	Operator
Write access	-

"Analog I/O" submenu

i There is a **Analog I/O** submenu for each Analog I/O module of the device. This submenu refers to terminals 1 to 3 of this module (an analog input or output). For terminals 4 to 8 (always an analog input) refer to → 132.

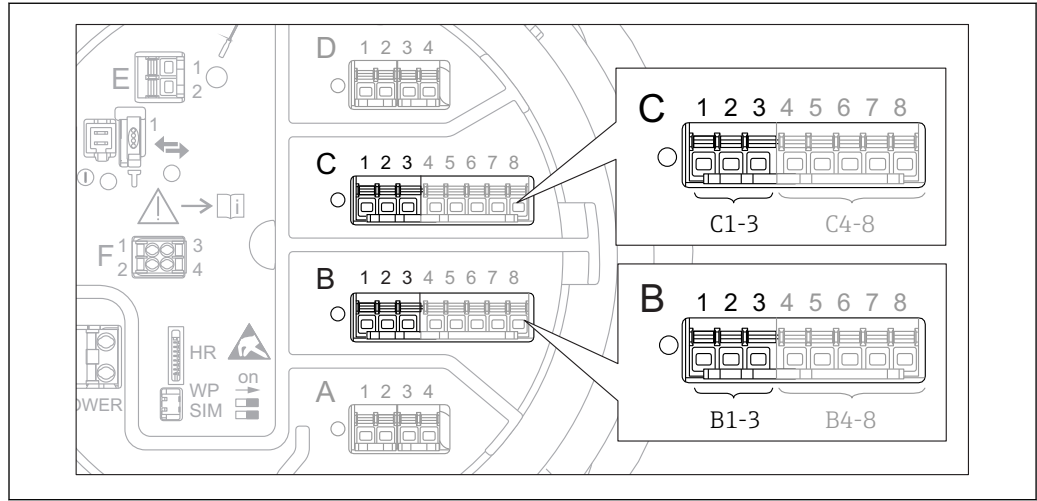

46 Terminals for the "Analog I/O" submenu ("B1-3" or "C1-3", respectively)

Navigation Setup → Advanced setup → Input/output → Analog I/O

Operating mode

Navigation Setup → Advanced setup → Input/output → Analog I/O → Operating mode

Description Defines the operating mode of the analog I/O module.

- Selection
- Disabled
 - 4..20mA input
 - HART master+4..20mA input
 - HART master
 - 4..20mA output
 - HART slave +4..20mA output

Factory setting Disabled

Additional information

Read access	Operator
Write access	Maintenance

Meaning of the options

Operating mode (→ 138)	Direction of signal	Type of signal
Disabled	-	-
4..20mA input	Input from 1 external device	Analog (4...20mA)
HART master+4..20mA input	Input from 1 external device	<ul style="list-style-type: none"> ■ Analog (4...20mA) ■ HART
HART master	Input from up to 6 external devices	HART

Operating mode (→ ⓘ 138)	Direction of signal	Type of signal
4...20mA output	Output to higher-level unit	Analog (4...20mA)
HART slave +4...20mA output	Output to higher-level unit	<ul style="list-style-type: none"> ■ Analog (4...20mA) ■ HART

Depending on the terminals used, the Analog I/O module is used in the passive or active mode.

Mode	Terminals of the I/O module		
	1	2	3
Passive (power supply from external source)	-	+	not used
Active (power supplied by the device itself)	not used	-	+

- i** In the active mode the following conditions must be met:
- Maximum current consumption of the connected HART devices: 24 mA (i.e. 4 mA per device if 6 devices are connected).
 - Output voltage of the Ex-d module: 17.0 V@4 mA to 10.5 V@22 mA
 - Output voltage of the Ex-ia module: 18.5 V@4 mA to 12.5 V@22 mA

Current span



Navigation Setup → Advanced setup → Input/output → Analog I/O → Current span

Prerequisite **Operating mode** parameter (→ ⓘ 138) ≠ **Disabled** option or **HART master** option

Description Defines the current range for the measured value transmission.

- Selection**
- 4...20 mA NAMUR
 - 4...20 mA US
 - 4...20 mA
 - Fixed current *

Factory setting 4...20 mA NAMUR

Additional information

Read access	Operator
Write access	Maintenance

Meaning of the options

Option	Current range for process variable	Lower alarm signal level	Upper alarm signal level
4...20 mA	4 to 20.5 mA	< 3.6 mA	> 21.95 mA
4...20 mA NAMUR	3.8 to 20.5 mA	< 3.6 mA	> 21.95 mA

* Visibility depends on order options or device settings

Option	Current range for process variable	Lower alarm signal level	Upper alarm signal level
4...20 mA US	3.9 to 20.8 mA	< 3.6 mA	> 21.95 mA
Fixed current	Constant current, defined in the Fixed current parameter (→ ⓘ 140).		

 In the case of an error, the output current assumes the value defined in the **Failure mode** parameter (→ ⓘ 141).

Fixed current 

Navigation   Setup → Advanced setup → Input/output → Analog I/O → Fixed current

Prerequisite **Current span** (→ ⓘ 139) = **Fixed current**

Description Defines the fixed output current.



User entry 4 to 22.5 mA

Factory setting 4 mA

Additional information

Read access	Operator
Write access	Maintenance

Analog input source 

Navigation   Setup → Advanced setup → Input/output → Analog I/O → Analog input source

Prerequisite

- **Operating mode** (→ ⓘ 138) = **4..20mA output** or **HART slave +4..20mA output**
- **Current span** (→ ⓘ 139) ≠ **Fixed current**

Description Defines the process variable transmitted via the AIO.

Selection

- None
- Tank level
- Tank level %
- Tank ullage
- Tank ullage %
- Measured level
- Distance
- Displacer position
- Water level
- Upper interface level
- Lower interface level
- Bottom level
- Tank reference height
- Liquid temperature
- Vapor temperature
- Air temperature

- Observed density value
- Average profile density ⁵⁾
- Upper density
- Middle density
- Lower density
- P1 (bottom)
- P2 (middle)
- P3 (top)
- GP 1 ... 4 value
- AIO B1-3 value ⁵⁾
- AIO B1-3 value mA ⁵⁾
- AIO C1-3 value ⁵⁾
- AIO C1-3 value mA ⁵⁾
- AIP B4-8 value ⁵⁾
- AIP C4-8 value ⁵⁾
- Element temperature 1 ... 24 ⁵⁾
- HART device 1...15 PV ⁵⁾
- HART device 1 ... 15 PV mA ⁵⁾
- HART device 1 ... 15 PV % ⁵⁾
- HART device 1 ... 15 SV ⁵⁾
- HART device 1 ... 15 TV ⁵⁾
- HART device 1 ... 15 QV ⁵⁾

Factory setting

Tank level

Additional information

Read access	Operator
Write access	Maintenance

Failure mode



Navigation

Setup → Advanced setup → Input/output → Analog I/O → Failure mode

Prerequisite

Operating mode (→ 138) = 4..20mA output or HART slave +4..20mA output

Description

Defines the output behavior in case of an error.

Selection

- Min.
- Max.
- Last valid value
- Actual value
- Defined value

Factory setting

Max.

Additional information

Read access	Operator
Write access	Maintenance

⁵⁾ Visibility depends on order options or device settings

Error value 

Navigation   Setup → Advanced setup → Input/output → Analog I/O → Error value

Prerequisite **Failure mode (→  141) = Defined value**

Description Defines the output value in case of an error.



User entry 3.4 to 22.6 mA

Factory setting 22 mA



Additional information

Read access	Operator
Write access	Maintenance

Input value

Navigation   Setup → Advanced setup → Input/output → Analog I/O → Input value

Prerequisite



- **Operating mode (→  138) = 4..20mA output or HART slave +4..20mA output**
- **Current span (→  139) ≠ Fixed current**

Description Shows the input value of the analog I/O module.



Additional information

Read access	Operator
Write access	-

0 % value 

Navigation   Setup → Advanced setup → Input/output → Analog I/O → 0 % value

Prerequisite

- **Operating mode (→  138) = 4..20mA output or HART slave +4..20mA output**
- **Current span (→  139) ≠ Fixed current**

Description Value corresponding to an output current of 0% (4mA).

User entry Signed floating-point number

Factory setting 0 Unitless

Additional information

Read access	Operator
Write access	Maintenance

100 % value

**Navigation**

Setup → Advanced setup → Input/output → Analog I/O → 100 % value

Prerequisite

- **Operating mode** (→ 138) = **4..20mA output** or **HART slave +4..20mA output**
- **Current span** (→ 139) ≠ **Fixed current**

Description

Value corresponding to an output current of 100% (20mA).

User entry

Signed floating-point number

Factory setting

0 Unitless

Additional information

Read access	Operator
Write access	Maintenance

Input value %

Navigation

Setup → Advanced setup → Input/output → Analog I/O → Input value %

Prerequisite

- **Operating mode** (→ 138) = **4..20mA output** or **HART slave +4..20mA output**
- **Current span** (→ 139) ≠ **Fixed current**

Description

Shows the output value as a percentage of the complete 4...20mA range.

Additional information

Read access	Operator
Write access	-

Output value

Navigation

Setup → Advanced setup → Input/output → Analog I/O → Output value

Prerequisite**Operating mode** (→ 138) = **4..20mA output** or **HART slave +4..20mA output****Description**

Shows the output value in mA.

Additional information

Read access	Operator
Write access	-

Process variable



- Navigation** Setup → Advanced setup → Input/output → Analog I/O → Process variable
- Prerequisite** **Operating mode (→ 138) = 4..20mA input or HART master+4..20mA input**
- Description** Defines the type of measuring variable.
- Selection**
 - Level linearized
 - Temperature
 - Pressure
 - Density
- Factory setting** Level linearized

Additional information

Read access	Operator
Write access	Maintenance

Analog input 0% value



- Navigation** Setup → Advanced setup → Input/output → Analog I/O → Analog input 0% value
- Prerequisite** **Operating mode (→ 138) = 4..20mA input or HART master+4..20mA input**
- Description** Value corresponding to an input current of 0% (4mA).
- User entry** -100 000 to 100 000 mm
- Factory setting** 0 mm

Additional information

Read access	Operator
Write access	Maintenance

Analog input 100% value



- Navigation** Setup → Advanced setup → Input/output → Analog I/O → Analog input 100% value
- Prerequisite** **Operating mode (→ 138) = 4..20mA input or HART master+4..20mA input**
- Description** Value corresponding to an input current of 100% (20mA).
- User entry** -100 000 to 100 000 mm
- Factory setting** 0 mm

Additional information

Read access	Operator
Write access	Maintenance

Error event type**Navigation**

Setup → Advanced setup → Input/output → Analog I/O → Error event type

Prerequisite

Operating mode (→ 138) ≠ Disabled or HART master

Description

Defines the type of event message (alarm/warning) in case of an error or output out of range in the analog I/O module.

Selection

- None
- Warning
- Alarm

Factory setting

Warning

Additional information

Read access	Operator
Write access	Maintenance

Process value**Navigation**

Setup → Advanced setup → Input/output → Analog I/O → Process value

Prerequisite

Operating mode (→ 138) = 4..20mA input or HART master+4..20mA input

Description

Shows the input value scaled to customer units.

Additional information

Read access	Operator
Write access	-

Input value in mA**Navigation**

Setup → Advanced setup → Input/output → Analog I/O → Input value in mA

Prerequisite

Operating mode (→ 138) = 4..20mA input or HART master+4..20mA input

Description

Shows the input value in mA.

Additional information

Read access	Operator
Write access	-

Input value percent

Navigation  Setup → Advanced setup → Input/output → Analog I/O → Input value percent

Prerequisite **Operating mode (→  138) = 4..20mA input or HART master+4..20mA input**

Description Shows the input value as a percentage of the complete 4...20mA current range.

Additional information

Read access	Operator
Write access	-

Damping factor



Navigation  Setup → Advanced setup → Input/output → Analog I/O → Damping factor

Prerequisite **Operating mode (→  138) ≠ Disabled or HART master**

Description Defines the damping constant (in seconds).

User entry 0 to 999.9 s

Factory setting 0 s

Additional information

Read access	Operator
Write access	Maintenance

Used for SIL/WHG



Navigation  Setup → Advanced setup → Input/output → Analog I/O → Used for SIL/WHG

Prerequisite

- **Operating mode (→  138) = 4..20mA output or HART slave +4..20mA output**
- The device has a SIL approval.

Description Determines whether the discrete I/O module is in SIL/WHG mode.

Selection

- Enabled
- Disabled

Factory setting Disabled

Additional information

Read access	Operator
Write access	Maintenance

Expected SIL/WHG chain

Navigation

  Setup → Advanced setup → Input/output → Analog I/O → Expected SIL/WHG chain

Prerequisite

- **Operating mode (→  138) = 4..20mA output or HART slave +4..20mA output**
- The device has a SIL approval.

Additional information

Read access	Operator
Write access	-

"Digital Xx-x" submenu

- i
 - In the operating menu, each digital input or output is designated by the respective slot of the terminal compartment and two terminals within this slot. **A1-2**, for example, denotes terminals 1 and 2 of slot **A**. The same is valid for slots **B**, **C** and **D** if they contain a Digital IO module.
 - In this document, **Xx-x** designates any of these submenus. The structure of all these submenus is the same.

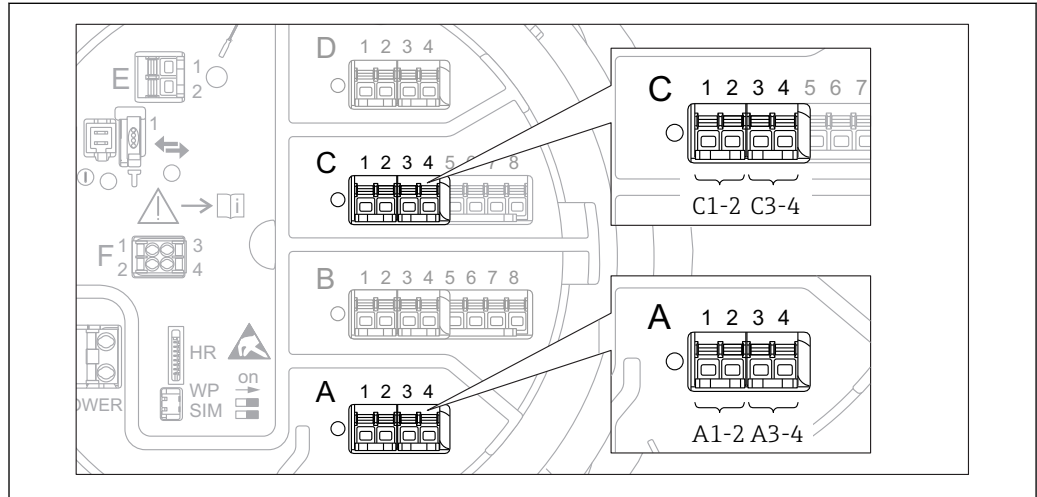

47 Designation of the digital inputs or outputs (examples)

Navigation Setup → Advanced setup → Input/output → Digital Xx-x

Operating mode

Navigation	Setup → Advanced setup → Input/output → Digital Xx-x → Operating mode
Description	Defines the operating mode of the discrete I/O module.
Selection	<ul style="list-style-type: none"> ▪ Disabled ▪ Output passive ▪ Input passive ▪ Input active
Factory setting	Disabled

Additional information

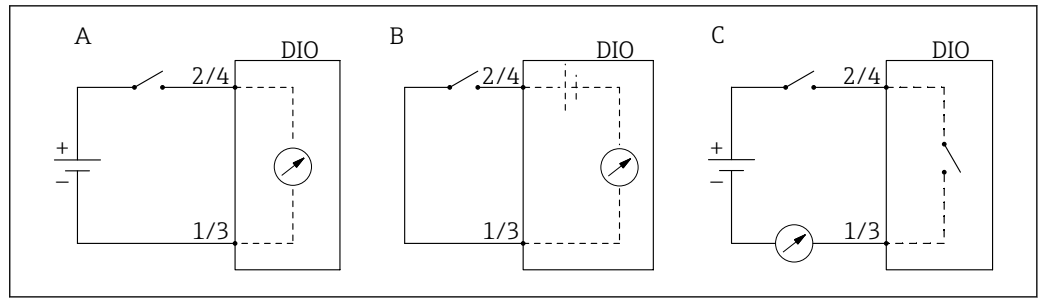

48 Operating modes of the Digital I/O module

- A Input passive
- B Input active
- C Output passive

A0033028

Digital input source



Navigation

Setup → Advanced setup → Input/output → Digital Xx-x → Digital input source

Prerequisite

Operating mode (→ 148) = Output passive

Description

Defines which device state is indicated by the digital output.

Selection

- None
- Alarm x any
- Alarm x High
- Alarm x HighHigh
- Alarm x High or HighHigh
- Alarm x Low
- Alarm x LowLow
- Alarm x Low or LowLow
- Digital Xx-x
- Pri. Modbus x
- Sec. Modbus x

Factory setting

None

Additional information

Meaning of the options

- Alarm x any, Alarm x High, Alarm x HighHigh, Alarm x High or HighHigh, Alarm x Low, Alarm x LowLow, Alarm x Low or LowLow

The digital output indicates if the selected alarm is currently active. The alarms themselves are defined in the **Alarm 1 to 4** submenus.

- Digital Xx-x⁶⁾

The digital signal present at the digital input Xx-x is passed through to the digital output.



- Modbus A1-4 Discrete x
- Modbus B1-4 Discrete x
- Modbus C1-4 Discrete x
- Modbus D1-4 Discrete x

The digital value written by the Modbus Master device to the **Modbus discrete x** parameter⁷⁾ is passed to the digital output. For details refer to Special Documentation SD02066G.

6) Only present if "Operating mode (→ 148)" = "Input passive" or "Input active" for the respective Digital I/O module.

7) Expert → Communication → Modbus Xx-x → Modbus discrete x

Input value



- Navigation**  Setup → Advanced setup → Input/output → Digital Xx-x → Input value
- Prerequisite** **Operating mode (→  148) = "Input passive" option or "Input active" option**
- Description** Shows the digital input value.

Additional information

Read access	Operator
Write access	-



Contact type



- Navigation**  Setup → Advanced setup → Input/output → Digital Xx-x → Contact type
- Prerequisite** **Operating mode (→  148) ≠ Disabled**
- Description** Determines the switching behavior of the input or output.
- Selection**
 - Normally open
 - Normally closed
- Factory setting** Normally open

Output simulation



- Navigation**  Setup → Advanced setup → Input/output → Digital Xx-x → Output simulation
- Prerequisite** **Operating mode (→  148) = Output passive**
- Description** Sets the output to a specific simulated value.
- Selection**
 - Disable
 - Simulating active
 - Simulating inactive
 - Fault 1
 - Fault 2
- Factory setting** Disable

Additional information

Read access	Operator
Write access	Maintenance

The digital output consists of two relays connected in series:

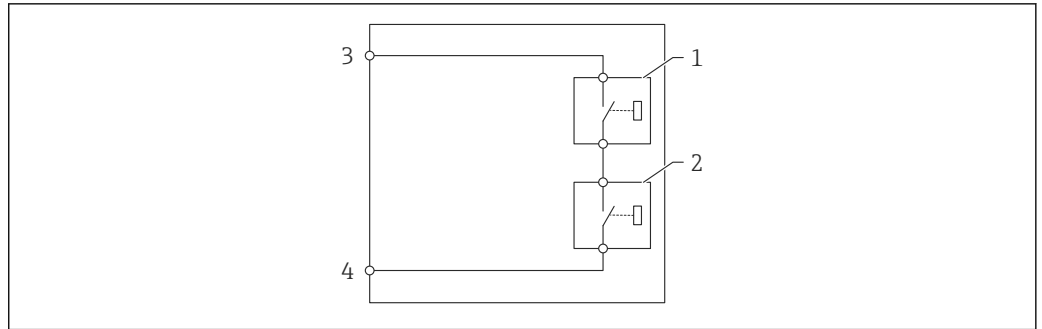

A0028602

49 The two relays of a digital output

1/2 The relays

3/4 The terminals of the digital output

The switching state of these relays is defined by the **Output simulation** parameter as follows:

Output simulation	State of relay 1	State of relay 2	Expected result on the terminals of the I/O module
Simulating active	Closed	Closed	Closed
Simulating inactive	Open	Open	Open
Fault 1	Closed	Open	Open
Fault 2	Open	Closed	Open

i The **Fault 1** and **Fault 2** options can be used to check the correct switching behavior of the two relays.

Output value

Navigation Setup → Advanced setup → Input/output → Digital Xx-x → Output values

Prerequisite **Operating mode (→ 148) = Output passive**

Description Shows the digital output value.

Additional information

Read access	Operator
Write access	-

Readback value

Navigation Setup → Advanced setup → Input/output → Digital Xx-x → Readback value

Prerequisite **Operating mode (→ 148) = Output passive**

Description Shows the value read back from the output.

Additional information

Read access	Operator
Write access	-

Used for SIL/WHG**Navigation**

Setup → Advanced setup → Input/output → Digital Xx-x → Used for SIL/WHG

Prerequisite

- **Operating mode (→ 148) = Output passive**
- The device has a SIL certificate.

Description

Determines whether the discrete I/O module is in SIL/WHG mode.

Selection

- Enabled
- Disabled

Factory setting

Disabled

Additional information

Read access	Operator
Write access	Maintenance

"Communication" submenu

This menu contains a submenu for each digital communication interface of the device. The communication interfaces are designated by "X1-4" where "X" specifies the slot in the terminal compartment and "1-4" the terminals within this slot.

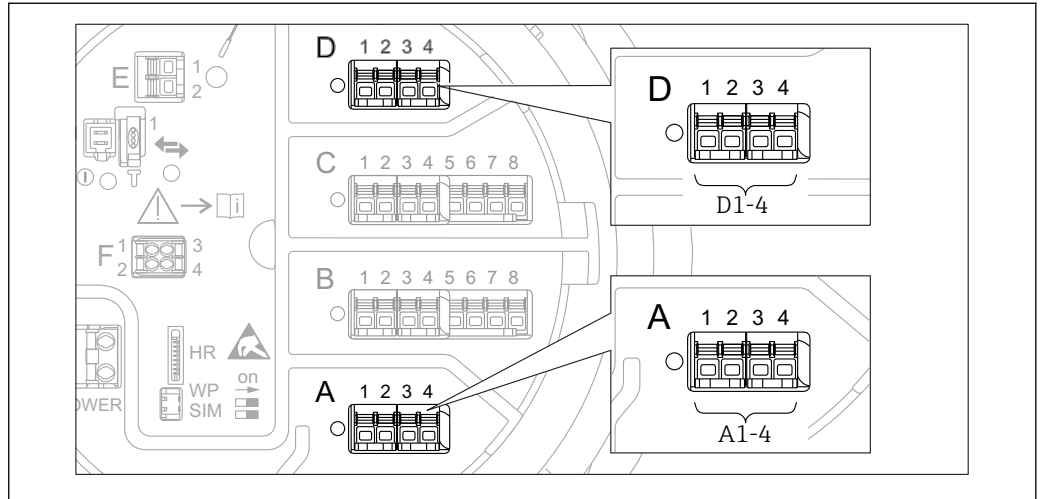

A0031200

50 Designation of the "Modbus" or "V1" modules (examples); depending on the device version these modules may also be in slot B or C.

Navigation Setup → Advanced setup → Communication

"Modbus X1-4" or "V1 X1-4" submenu

This submenu is only present for devices with **MODBUS** and/or **V1** communication interface. There is one submenu of this type for each communication interface.

Navigation Setup → Advanced setup → Communication → Modbus X1-4 / V1 X1-4

Communication interface protocol

Navigation Setup → Advanced setup → Communication → Modbus X1-4 / V1 X1-4 → Communication interface protocol

Description Shows the type of communication protocol.

Additional information

Read access	Operator
Write access	-

"Configuration" submenu

This submenu is only present for devices with a **MODBUS** communication interface.

Navigation  Setup → Advanced setup → Communication → Modbus X1-4 → Configuration

Baudrate 

Navigation  Setup → Advanced setup → Communication → Modbus X1-4 → Configuration → Baudrate

Prerequisite **Communication interface protocol (→  153) = MODBUS**

Description Defines the baud rate of the Modbus communication.

- Selection**
- 300 BAUD
 - 600 BAUD
 - 1200 BAUD
 - 2400 BAUD
 - 4800 BAUD
 - 9600 BAUD
 - 19200 BAUD

Factory setting 9600 BAUD

Additional information

Read access	Operator
Write access	Maintenance

Parity 

Navigation  Setup → Advanced setup → Communication → Modbus X1-4 → Configuration → Parity

Prerequisite **Communication interface protocol (→  153) = MODBUS**

Description Defines the parity of the Modbus communication.

- Selection**
- Odd
 - Even
 - None / 1 stop bit
 - None / 2 stop bits

Factory setting None / 1 stop bit

Additional information

Read access	Operator
Write access	Maintenance

Modbus address



Navigation Setup → Advanced setup → Communication → Modbus X1-4 → Configuration → Device ID

Prerequisite **Communication interface protocol (→ 153) = MODBUS**

Description Defines the Modbus address of the device.

User entry 1 to 247

Factory setting 1

Additional information

Read access	Operator
Write access	Maintenance

Float swap mode



Navigation Setup → Advanced setup → Communication → Modbus X1-4 → Configuration → Float swap mode

Prerequisite **Communication interface protocol (→ 153) = MODBUS**

Description Sets the format of how the floating point value is transferred on Modbus.

- Selection**
- Normal 3-2-1-0
 - Swap 0-1-2-3
 - WW Swap 1-0-3-2

Factory setting Swap 0-1-2-3

Additional information

Read access	Operator
Write access	Maintenance

Bus termination



Navigation Setup → Advanced setup → Communication → Modbus X1-4 → Configuration → Bus termination

Prerequisite **Communication interface protocol (→ 153) = MODBUS**

Description Activates or deactivates the bus termination at the device. Should only be activated on the last device in a loop.

- Selection**
- Off
 - On

Factory setting Off

Additional information

Read access	Operator
Write access	Maintenance

"Configuration" submenu

This submenu is only present for devices with a **V1** communication interface.

Navigation  Setup → Advanced setup → Communication → V1 X1-4 → Configuration

Communication interface protocol variant 

Navigation  Setup → Advanced setup → Communication → V1 X1-4 → Configuration → Communication interface protocol variant

Description Determines which variant of the V1 protocol is used.

User interface

- None
- V1*

Factory setting None

Additional information

Read access	Operator
Write access	Maintenance

V1 address 

Navigation  Setup → Advanced setup → Communication → V1 X1-4 → Configuration → V1 address

Prerequisite **Communication interface protocol variant (→  157) = V1**

Description Identifier of the device for the V1 communication.

User entry 0 to 99

Factory setting 1

Additional information

Read access	Operator
Write access	Maintenance

* Visibility depends on order options or device settings

V1 address



Navigation Setup → Advanced setup → Communication → V1 X1-4 → Configuration → V1 address

Prerequisite **Communication interface protocol variant (→ 157)**

Description Identifier of the previous device for V1 communication.

User entry 0 to 255

Factory setting 1

Additional information

Read access	Operator
Write access	Maintenance

Level mapping



Navigation Setup → Advanced setup → Communication → V1 X1-4 → Configuration → Level mapping

Prerequisite **Communication interface protocol (→ 153) = V1**

Description Determines the transmittable range of levels.

Selection

- +ve
- +ve & -ve

Factory setting +ve

Additional information

Read access	Operator
Write access	Maintenance

In V1, the level is always represented by a number in the range from 0 to 999 999. This number corresponds to a level as follows:

"Level mapping" = "+ve"

Number	Corresponding level
0	0.0 mm
999 999	99 999.9 mm

"Level mapping" = "+ve & -ve"

Number	Corresponding level
0	0.0 mm
500 000	50 000.0 mm

Number	Corresponding level
500 001	-0.1 mm
999 999	-49 999.9 mm

Line impedance



Navigation Setup → Advanced setup → Communication → V1 X1-4 → Configuration → Line impedance

Prerequisite **Communication interface protocol (→ 153) = V1**

Description Adjusts the impedance of the communication line.

User entry 0 to 15

Factory setting 15

Additional information

Read access	Operator
Write access	Maintenance

The line impedance affects the voltage difference between a logical 0 and a logical 1 on the message of the device to the bus. The default setting is suitable for most applications.

"V1 input selector" submenu

This submenu is only present for devices with a **V1** communication interface.

Navigation  Setup → Advanced setup → Communication → V1 X1-4 → V1 input selector

Alarm 1 input source 

Navigation  Setup → Advanced setup → Communication → V1 X1-4 → V1 input selector → Alarm 1 input source

Description Determines which discrete value will be transmitted as V1 alarm 1 status.

- Selection**
- None
 - Alarm 1-4 any
 - Alarm 1-4 HighHigh
 - Alarm 1-4 High or HighHigh
 - Alarm 1-4 High
 - Alarm 1-4 Low
 - Alarm 1-4 Low or LowLow
 - Alarm 1-4 LowLow

Factory setting None

Additional information

Read access	Operator
Write access	Maintenance

Alarm 2 input source 

Navigation  Setup → Advanced setup → Communication → V1 X1-4 → V1 input selector → Alarm 2 input source

Description Determines which discrete value will be transmitted as V1 alarm 2 status.

- Selection**
- None
 - Alarm 1-4 any
 - Alarm 1-4 HighHigh
 - Alarm 1-4 High or HighHigh
 - Alarm 1-4 High
 - Alarm 1-4 Low
 - Alarm 1-4 Low or LowLow
 - Alarm 1-4 LowLow

Factory setting None

Additional information

Read access	Operator
Write access	Maintenance

Value percent selector**Navigation**

Setup → Advanced setup → Communication → V1 X1-4 → V1 input selector → Value percent selector

Description

Selects which value shall be transmitted as a 0..100% value in the V1 Z0/Z1 message.

Selection

- None
- Tank level %
- Tank ullage %
- AIO B1-3 value % *
- AIO C1-3 value % *

Factory setting

None

Additional information

Read access	Operator
Write access	Maintenance

* Visibility depends on order options or device settings

"HART output" submenu

Navigation  Setup → Advanced setup → Communication → HART output

"Configuration" submenu

Navigation  Setup → Advanced setup → Communication → HART output
→ Configuration

System polling address 

Navigation  Setup → Advanced setup → Communication → HART output → Configuration
→ System polling address

Description Device address for HART communication.

User entry 0 to 63

Factory setting 15

Additional information

Read access	Operator
Write access	Maintenance

No. of preambles 

Navigation  Setup → Advanced setup → Communication → HART output → Configuration → No.
of preambles

Description Defines the number o preambles in the HART telegram.

User entry 5 to 20

Factory setting 5

Additional information

Read access	Operator
Write access	Maintenance

PV source 

Navigation  Setup → Advanced setup → Communication → HART output → Configuration → PV
source

Description Decides, if the PV configuration is according to an analog output (HART slave) or
customized (in case of HART tunneling only).

- Selection**
- AIO B1-3 *
 - AIO C1-3 *
 - Custom

Factory setting Custom

Additional information

Read access	Maintenance
Write access	Maintenance

Assign PV



Navigation Setup → Advanced setup → Communication → HART output → Configuration → Assign PV

Prerequisite **PV source (→ 162) = Custom**

Description Assigns a tank variable to the primary HART variable (PV).

- Selection**
- None
 - Tank level
 - Tank ullage
 - Measured level
 - Distance
 - Displacer position
 - Water level
 - Upper interface level
 - Lower interface level
 - Bottom level
 - Tank reference height
 - Liquid temperature
 - Vapor temperature
 - Air temperature
 - Observed density value
 - Average profile density
 - Upper density
 - Middle density
 - Lower density
 - P1 (bottom)
 - P2 (middle)
 - P3 (top)
 - GP 1 value
 - GP 2 value
 - GP 3 value
 - GP 4 value

Factory setting Tank level

* Visibility depends on order options or device settings

Additional information

Read access	Operator
Write access	Maintenance

 The **Measured level** option doesn't contain a unit. If a unit is needed, select the **Tank level** option.

0 % value



Navigation

 Setup → Advanced setup → Communication → HART output → Configuration → 0 % value

Prerequisite

PV source = Custom

Description

0% value of the primary variable (PV).

User entry

-100 000 to 100 000 mm

Factory setting

0 mm

Additional information

Read access	Operator
Write access	Maintenance

100 % value



Navigation

 Setup → Advanced setup → Communication → HART output → Configuration → 100 % value

Prerequisite

PV source = Custom

Description

100% value of the primary variable (PV).

User entry

-100 000 to 100 000 mm

Factory setting

0 mm

Additional information

Read access	Operator
Write access	Maintenance

PV mA selector



Navigation

 Setup → Advanced setup → Communication → HART output → Configuration → PV mA selector

Prerequisite

PV source = Custom

Description Assigns a current to the primary HART variable (PV).



Selection

- None
- AIO B1-3 value mA *
- AIO C1-3 value mA *

Factory setting None

Additional information	Read access	Operator
	Write access	Maintenance



Primary variable (PV)

Navigation   Setup → Advanced setup → Communication → HART output → Configuration → Primary variable (PV)

Description Shows the value of the primary HART variable (PV).

Additional information	Read access	Operator
	Write access	-

Percent of range



Navigation   Setup → Advanced setup → Communication → HART output → Configuration → Percent of range

Description Shows the value of the primary variable (PV) as a percentage of the defined 0% to 100% range.

Additional information	Read access	Operator
	Write access	-

Assign SV



Navigation   Setup → Advanced setup → Communication → HART output → Configuration → Assign SV

Description Assigns a tank variable to the secondary HART variable (SV).

Selection

- None
- Tank level
- Tank ullage

* Visibility depends on order options or device settings

- Measured level
- Distance
- Displacer position
- Water level
- Upper interface level
- Lower interface level
- Bottom level
- Tank reference height
- Liquid temperature
- Vapor temperature
- Air temperature
- Observed density value
- Average profile density
- Upper density
- Middle density
- Lower density
- P1 (bottom)
- P2 (middle)
- P3 (top)
- GP 1 value
- GP 2 value
- GP 3 value
- GP 4 value

Factory setting

Liquid temperature

Additional information

Read access	Operator
Write access	Maintenance

 The **Measured level** option doesn't contain a unit. If a unit is needed, select the **Tank level** option.

Secondary variable (SV)

Navigation

 Setup → Advanced setup → Communication → HART output → Configuration → Secondary variable (SV)

Prerequisite

Assign SV (→  165) ≠ None

Description

Shows the value of the secondary HART variable (SV).

Additional information

Read access	Operator
Write access	-

Assign TV



Navigation Setup → Advanced setup → Communication → HART output → Configuration → Assign TV

Description Assigns a tank variable to the third HART variable (TV).

- Selection**
- None
 - Tank level
 - Tank ullage
 - Measured level
 - Distance
 - Displacer position
 - Water level
 - Upper interface level
 - Lower interface level
 - Bottom level
 - Tank reference height
 - Liquid temperature
 - Vapor temperature
 - Air temperature
 - Observed density value
 - Average profile density
 - Upper density
 - Middle density
 - Lower density
 - P1 (bottom)
 - P2 (middle)
 - P3 (top)
 - GP 1 value
 - GP 2 value
 - GP 3 value
 - GP 4 value

Factory setting Water level

Additional information

Read access	Operator
Write access	Maintenance

The **Measured level** option doesn't contain a unit. If a unit is needed, select the **Tank level** option.

Tertiary variable (TV)

Navigation Setup → Advanced setup → Communication → HART output → Configuration → Tertiary variable (TV)

Prerequisite Assign TV (→ 167) ≠ None

Description Shows the value of the third HART variable (TV).

Additional information

Read access	Operator
Write access	-

Assign QV



Navigation

Setup → Advanced setup → Communication → HART output → Configuration → Assign QV

Description

Assigns a tank variable to the fourth HART variable (QV).

Selection

- None
- Tank level
- Tank ullage
- Measured level
- Distance
- Displacer position
- Water level
- Upper interface level
- Lower interface level
- Bottom level
- Tank reference height
- Liquid temperature
- Vapor temperature
- Air temperature
- Observed density value
- Average profile density
- Upper density
- Middle density
- Lower density
- P1 (bottom)
- P2 (middle)
- P3 (top)
- GP 1 value
- GP 2 value
- GP 3 value
- GP 4 value

Factory setting

Observed density value

Additional information

Read access	Operator
Write access	Maintenance

The **Measured level** option doesn't contain a unit. If a unit is needed, select the **Tank level** option.

Quaternary variable (QV)

Navigation

☰☰ Setup → Advanced setup → Communication → HART output → Configuration
→ Quaternary variable (QV)

Prerequisite

Assign QV (→ 📄 168) ≠ None

Description

Shows the value of the fourth HART variable (QV).

Additional information

Read access	Operator
Write access	-

"Information" submenu

Navigation  Setup → Advanced setup → Communication → HART output → Information

HART short tag 

Navigation  Setup → Advanced setup → Communication → HART output → Information → HART short tag

Description Defines the short tag for the measuring point. Maximum length: 8 characters Allowed characters: A-Z, 0-9, certain special characters.

Factory setting NRF8x

Additional information

Read access	Operator
Write access	Maintenance

Device tag 

Navigation  Setup → Advanced setup → Communication → HART output → Information → Device tag

Description Enter a unique name for the measuring point to identify the device quickly within the plant.

Factory setting NRF8x

Additional information

Read access	Operator
Write access	Maintenance

HART descriptor 

Navigation  Setup → Advanced setup → Communication → HART output → Information → HART descriptor

Description User defined HART descriptor (16 characters).

Factory setting NRF8x

Additional information

Read access	Operator
Write access	Maintenance

HART message
**Navigation**

Setup → Advanced setup → Communication → HART output → Information → HART message

Description

User defined HART message (32 characters).

Factory setting

NRF8x

Additional information

Read access	Operator
Write access	Maintenance

HART date code
**Navigation**

Setup → Advanced setup → Communication → HART output → Information → HART date code

Description

Enter date of the last configuration change. Use this format yyyy-mm-dd.

Factory setting

2009-07-20

Additional information

Read access	Operator
Write access	Maintenance

"Application" submenu

Navigation  Setup → Advanced setup → Application

"Tank configuration" submenu

Navigation  Setup → Advanced setup → Application → Tank configuration

"Level" submenu

Navigation  Setup → Advanced setup → Application → Tank configuration → Level

Level source 

Navigation  Setup → Advanced setup → Application → Tank configuration → Level → Level source

Description Defines the source of the level value.

- Selection**
- No input value
 - HART device 1 ... 15 level
 - Level SR*
 - Level*
 - Displacer position*
 - AIO B1-3 value*
 - AIO C1-3 value*
 - AIP B4-8 value*
 - AIP C4-8 value*

Factory setting Dependent on the device version

Additional information

Read access	Operator
Write access	Maintenance

Operation mode 

Navigation  Setup → Advanced setup → Application → Tank configuration → Level → Operation mode

Description Selection of normal or HTG mode for level measurement . In the HTG mode, the level is calculated using a pressure device.

* Visibility depends on order options or device settings

Selection

- Normal
- HTG^{*}

Factory setting Normal

Additional information

Read access	Operator
Write access	Maintenance

Tank reference height



Navigation Setup → Advanced setup → Application → Tank configuration → Level → Tank reference height

Description Defines the distance from the dipping reference point to the zero position (tank bottom or datum plate).

User entry 0 to 10 000.00 mm

Factory setting Dependent on the device version

Additional information

Read access	Operator
Write access	Maintenance

Tank level

Navigation Setup → Advanced setup → Application → Tank configuration → Level → Tank level

Description Shows the distance from the zero position (tank bottom or datum plate) to the product surface.

Additional information

Read access	Operator
Write access	-

Water level source



Navigation Setup → Advanced setup → Application → Tank configuration → Level → Water level source

Description Defines the source of the bottom water level.

* Visibility depends on order options or device settings

- Selection**
- Manual value
 - Bottom level
 - HART device 1 ... 15 level
 - AIO B1-3 value
 - AIO C1-3 value
 - AIP B4-8 value
 - AIP C4-8 value

Factory setting Manual value

Additional information

Read access	Operator
Write access	Maintenance

Manual water level



Navigation Setup → Advanced setup → Application → Tank configuration → Level → Manual water level

Prerequisite **Water level source (→ 173) = Manual value**

Description Defines the manual value of the bottom water level.

User entry -2 000 to 5 000 mm

Factory setting 0 mm

Additional information

Read access	Operator
Write access	Maintenance

Water level

Navigation Setup → Advanced setup → Application → Tank configuration → Level → Water level

Description Shows the bottom water level.

Additional information

Read access	Operator
Write access	-

"Temperature" submenu

Read access	Maintenance
-------------	-------------

Navigation  Setup → Advanced setup → Application → Tank configuration → Temperature

Liquid temp source 

Navigation  Setup → Advanced setup → Application → Tank configuration → Temperature → Liquid temp source

Description Defines source from which the liquid temperature is obtained.

- Selection**
- Manual value
 - HART device 1 ... 15 temperature
 - AIO B1-3 value
 - AIO C1-3 value
 - AIP B4-8 value
 - AIP C4-8 value

Factory setting Manual value

Additional information

Read access	Operator
Write access	Maintenance

Manual liquid temperature 

Navigation  Setup → Advanced setup → Application → Tank configuration → Temperature → Manual liquid temperature

Prerequisite **Liquid temp source (→  123) = Manual value**

Description Defines the manual value of the liquid temperature.



User entry -50 to 300 °C

Factory setting 25 °C

Additional information

Read access	Operator
Write access	Maintenance

Liquid temperature

Navigation   Setup → Advanced setup → Application → Tank configuration → Temperature → Liquid temperature

Description Shows the average or spot temperature of the measured liquid.

Additional information

Read access	Operator
Write access	-

Air temperature source

Navigation   Setup → Advanced setup → Application → Tank configuration → Temperature → Air temperature source

Description Defines source from which the air temperature is obtained.



- Selection**
- Manual value
 - HART device 1 ... 15 temperature
 - AIO B1-3 value
 - AIO C1-3 value
 - AIP B4-8 value
 - AIP C4-8 value

Factory setting Manual value

Additional information

Read access	Operator
Write access	Maintenance

Manual air temperature

Navigation   Setup → Advanced setup → Application → Tank configuration → Temperature → Manual air temperature

Prerequisite **Air temperature source** (→  176) = **Manual value**

Description Defines the manual value of the air temperature.

User entry -50 to 300 °C

Factory setting 25 °C

Additional information

Read access	Operator
Write access	Maintenance

Air temperature

Navigation  Setup → Advanced setup → Application → Tank configuration → Temperature → Air temperature

Description Shows the air temperature.

Additional information

Read access	Operator
Write access	-

Vapor temp source



Navigation  Setup → Advanced setup → Application → Tank configuration → Temperature → Vapor temp source

Description Defines the source from which the vapor temperature is obtained.

Selection

- Manual value
- HART device 1 ... 15 vapor temp
- AIO B1-3 value
- AIO C1-3 value
- AIP B4-8 value
- AIP C4-8 value

Factory setting Manual value

Additional information

Read access	Operator
Write access	Maintenance

Manual vapor temperature



Navigation  Setup → Advanced setup → Application → Tank configuration → Temperature → Manual vapor temperature

Prerequisite **Vapor temp source (→  177) = Manual value**

Description Defines the manual value of the vapor temperature.

User entry -50 to 300 °C

Factory setting 25 °C

Additional information

Read access	Operator
Write access	Maintenance

Vapor temperature

Navigation

 Setup → Advanced setup → Application → Tank configuration → Temperature
→ Vapor temperature

Description

Shows the measured vapor temperature.

Additional information

Read access	Operator
Write access	-

"Density" submenu

Navigation  Setup → Advanced setup → Application → Tank configuration → Density

Observed density source 

Navigation  Setup → Advanced setup → Application → Tank configuration → Density → Observed density source

Description Determines how the density is obtained.

- Selection**
- HTG *
 - HTMS *
 - Average profile density *
 - Upper density
 - Middle density
 - Lower density

Factory setting Dependent on the device version

Additional information

Read access	Operator
Write access	Maintenance

Observed density

Navigation  Setup → Advanced setup → Application → Tank configuration → Density → Observed density

Description Shows the measured or calculated density.

Additional information

Read access	Operator
Write access	-

Air density 

Navigation  Setup → Advanced setup → Application → Tank configuration → Density → Air density

Description Defines the density of the air surrounding the tank.

User entry 0.0 to 500.0 kg/m³

* Visibility depends on order options or device settings

Factory setting 1.2 kg/m³

Additional information

Read access	Operator
Write access	Maintenance

Vapor density



Navigation

Setup → Advanced setup → Application → Tank configuration → Density → Vapor density

Description

Defines the density of the gas phase in the tank.

User entry

0.0 to 500.0 kg/m³

Factory setting

1.2 kg/m³

Additional information

Read access	Operator
Write access	Maintenance

"Pressure" submenu

Navigation  Setup → Advanced setup → Application → Tank configuration → Pressure → Pressure

P1 (bottom) source 

Navigation  Setup → Advanced setup → Application → Tank configuration → Pressure → P1 (bottom) source

Description Defines the source of the bottom pressure (P1).

- Selection**
- Manual value
 - HART device 1 ... 15 pressure
 - AIO B1-3 value
 - AIO C1-3 value
 - AIP B4-8 value
 - AIP C4-8 value

Factory setting Manual value

Additional information

Read access	Operator
Write access	Maintenance

P1 (bottom)

Navigation  Setup → Advanced setup → Application → Tank configuration → Pressure → P1 (bottom)

Description Shows the pressure at the tank bottom.

Additional information

Read access	Operator
Write access	-

P1 (bottom) manual pressure 

Navigation  Setup → Advanced setup → Application → Tank configuration → Pressure → P1 (bottom) manual pressure

Prerequisite P1 (bottom) source (→  181) = Manual value

Description Defines the manual value of the bottom pressure (P1).

User entry -25 to 25 bar

Factory setting 0 bar

Additional information

Read access	Operator
Write access	Maintenance

P1 position 

Navigation

  Setup → Advanced setup → Application → Tank configuration → Pressure → P1 position

Description

Defines the position of the bottom pressure transmitter (P1), measured from zero position (tank bottom or datum plate).

User entry

-10 000 to 100 000 mm

Factory setting

5 000 mm

Additional information

Read access	Operator
Write access	Maintenance

P1 offset 

Navigation

  Setup → Advanced setup → Application → Tank configuration → Pressure → P1 offset

Description

Offset for the bottom pressure (P1). The offset is added to the measured pressure prior to any tank calculation.

User entry

-25 to 25 bar

Factory setting

0 bar

Additional information

Read access	Operator
Write access	Maintenance

P1 absolute / gauge 

Navigation

  Setup → Advanced setup → Application → Tank configuration → Pressure → P1 absolute / gauge

Description

Defines whether the connected pressure transmitter measures an absolute or a gauge pressure.

Selection

- Absolute
- Gauge

Factory setting

Gauge

Additional information

Read access	Operator
Write access	Maintenance

P2 (middle) source**Navigation**

Setup → Advanced setup → Application → Tank configuration → Pressure → P2 (middle) source

Description

Defines the source of the middle pressure (P2).

Selection

- Manual value
- HART device 1 ... 15 pressure
- AIO B1-3 value
- AIO C1-3 value
- AIP B4-8 value
- AIP C4-8 value

Factory setting

Manual value

Additional information

Read access	Operator
Write access	Maintenance

P2 (middle)**Navigation**

Setup → Advanced setup → Application → Tank configuration → Pressure → P2 (middle)

Description

Shows the pressure (P2) at the middle transmitter.

Additional information

Read access	Operator
Write access	-

P2 (middle) manual pressure**Navigation**

Setup → Advanced setup → Application → Tank configuration → Pressure → P2 (middle) manual pressure

Prerequisite

P2 (middle) source (→ 183) = **Manual value**

Description

Defines the manual value of the middle pressure (P2).

User entry

-25 to 25 bar

Factory setting 0 bar

Additional information

Read access	Operator
Write access	Maintenance

P2 offset 

Navigation   Setup → Advanced setup → Application → Tank configuration → Pressure → P2 offset

Description Defines the offset for the middle pressure (P2). The offset is added to the measured pressure prior to any tank calculation.

User entry -25 to 2.5 bar

Factory setting 0 bar

Additional information

Read access	Operator
Write access	Maintenance

P1-2 distance 

Navigation   Setup → Advanced setup → Application → Tank configuration → Pressure → P1-2 distance

Description Defines the distance between the bottom and the middle pressure transmitter.

User entry 0 to 100 000 mm

Factory setting 2 000 mm

Additional information

Read access	Operator
Write access	Maintenance

P2 absolute / gauge 

Navigation   Setup → Advanced setup → Application → Tank configuration → Pressure → P2 absolute / gauge

Description Defines whether the connected pressure transmitter measures an absolute or a gauge pressure.

Selection

- Absolute
- Gauge

Factory setting

Gauge

Additional information

Read access	Operator
Write access	Maintenance

P3 (top) source**Navigation**

Setup → Advanced setup → Application → Tank configuration → Pressure → P3 (top) source

Description

Defines the source of the top pressure (P3).

Selection

- Manual value
- HART device 1 ... 15 pressure
- AIO B1-3 value
- AIO C1-3 value
- AIP B4-8 value
- AIP C4-8 value

Factory setting

Manual value

Additional information

Read access	Operator
Write access	Maintenance

P3 (top)**Navigation**

Setup → Advanced setup → Application → Tank configuration → Pressure → P3 (top)

Description

Shows the pressure (P3) at the top transmitter.

Additional information

Read access	Operator
Write access	-

P3 (top) manual pressure**Navigation**

Setup → Advanced setup → Application → Tank configuration → Pressure → P3 (top) manual pressure

Prerequisite

P3 (top) source (→ 185) = Manual value

Description

Defines the manual value of the top pressure (P3).

User entry

-2.5 to 2.5 bar

Factory setting

0 bar

Additional information

Read access	Operator
Write access	Maintenance

P3 position



Navigation

Setup → Advanced setup → Application → Tank configuration → Pressure → P3 position

Description

Defines the position of the top pressure transmitter (P3), measured from zero position (tank bottom or datum plate).

User entry

0 to 100 000 mm

Factory setting

20 000 mm

Additional information

Read access	Operator
Write access	Maintenance

P3 offset



Navigation

Setup → Advanced setup → Application → Tank configuration → Pressure → P3 offset

Description

Offset for the top pressure (P3). The offset is added to the measured pressure prior to any tank calculation.

User entry

-2.5 to 2.5 bar

Factory setting

0 bar

Additional information

Read access	Operator
Write access	Maintenance

P3 absolute / gauge



Navigation

Setup → Advanced setup → Application → Tank configuration → Pressure → P3 absolute / gauge

Description

Defines whether the connected pressure transmitter measures an absolute or a gauge pressure.

Selection

- Absolute
- Gauge

Factory setting

Gauge

Additional information

Read access	Operator
Write access	Maintenance

Ambient pressure



Navigation

Setup → Advanced setup → Application → Tank configuration → Pressure → Ambient pressure

Description

Defines the manual value of the ambient pressure.

User entry

0 to 2.5 bar

Factory setting

1 bar

Additional information

Read access	Operator
Write access	Maintenance

"Tank calculation" submenu

Navigation  Setup → Advanced setup → Application → Tank calculation

*"HyTD" submenu**Overview*

Hydrostatic Tank Deformation can be used to compensate the vertical movement of the Gauge Reference Height (GRH) due to bulging of the tank shell caused by the hydrostatic pressure exerted by the liquid stored in the tank. The compensation is based on a linear approximation obtained from manual hand dips at several levels distributed over the full range of the tank.

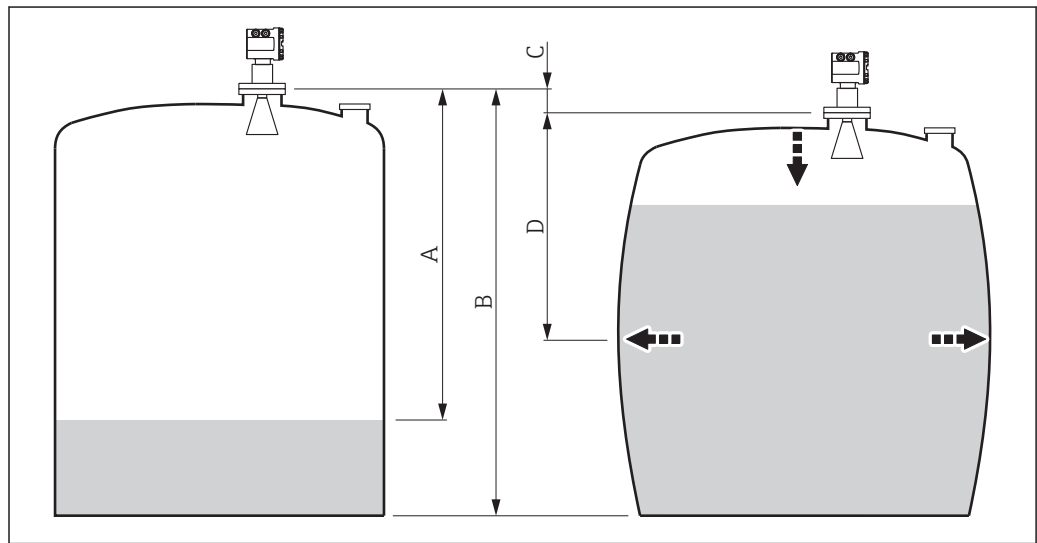

 51 Correction of the hydrostatic tank deformation (HyTD)

- A "Distance" (level below L_0 → "HyTD correction value" = 0)
- B Gauge Reference Height (GRH)
- C HyTD correction value
- D "Distance" (level above L_0 → "HyTD correction value" > 0)

 This mode should not be used in conjunction with HTG as with HTG the level is not measured relative to the gauge reference height.

Linear approximation of the HyTD correction

The real amount of deformation varies non-linearly with the level due to the construction of the tank. However, as the correction values are typically small compared to the measured level, a simple straight line method can be used with good results.

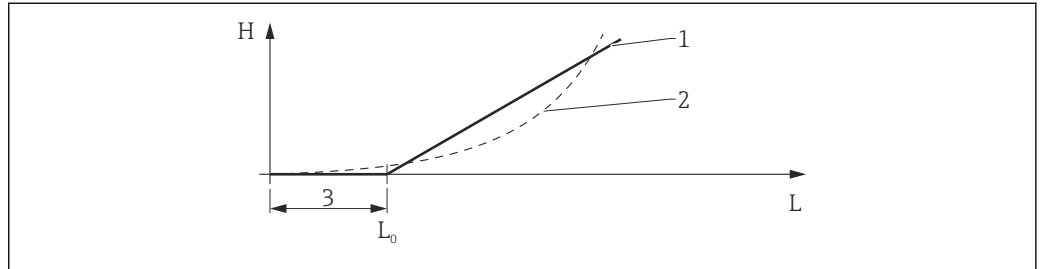

A0028724

52 Calculation of the HyTD correction

- 1 Linear correction according to "Deformation factor (→ 191)"
- 2 Real correction
- 3 Starting level (→ 190)
- L Measured level
- H HyTD correction value (→ 190)

Calculation of the HyTD correction

$$L \leq L_0 \Rightarrow C_{HyTD} = 0$$

$$L > L_0 \Rightarrow C_{HyTD} = - (L - L_0) \times D$$

A0028715

L	Measured level
L₀	Starting level
C_{HyTD}	HyTD correction value
D	Deformation factor

Description of parameters

Navigation  Setup → Advanced setup → Application → Tank calculation → HyTD

HyTD correction value

Navigation  Setup → Advanced setup → Application → Tank calculation → HyTD → HyTD correction value

Description Shows the correction value from the Hydrostatic Tank Deformation.

Additional information

Read access	Operator
Write access	-

HyTD mode



Navigation  Setup → Advanced setup → Application → Tank calculation → HyTD → HyTD mode

Description Activates or deactivates the calculation of the Hydrostatic Tank Deformation.

Selection No
 Yes

Factory setting No

Additional information

Read access	Operator
Write access	Maintenance

Starting level



Navigation  Setup → Advanced setup → Application → Tank calculation → HyTD → Starting level

Description Defines the starting level for the Hydrostatic Tank Deformation. Levels below this value are not corrected.

User entry 0 to 5 000 mm

Factory setting 500 mm

Additional information

Read access	Operator
Write access	Maintenance

Deformation factor

**Navigation**

Setup → Advanced setup → Application → Tank calculation → HyTD → Deformation factor

Description

Defines the deformation factor for the HyTD (change of device position per change of level).

User entry

-1.0 to 1.0 %

Factory setting



0.2 %

Additional information

Read access	Operator
Write access	Maintenance

*"CTSh" submenu**Overview*

CTSh (correction for the thermal expansion of the tank shell) compensates for effects on the Gauge Reference Height (GRH) and on the expansion or contraction of the measuring wire due to temperature effects on the tank shell or stilling well. The temperature effects are separated into two parts, respectively affecting the 'dry' and 'wetted' part of the tank shell or stilling well. The correction function is based on thermal expansion coefficients of steel and insulation factors for both the 'dry' and 'wet' parts of the wire and the tank shell. The temperatures used for the correction can be selected from on manual or measured values.

-  This correction is recommended for the following situations:
 - if the operating temperature deviates considerably from the temperature during calibration ($\Delta T > 10\text{ °C}$ (18 °F))
 - for extremely high tanks
 - for refrigerated, cryogenic or heated applications
-  As the use of this correction will influence the innage level reading, it is recommended to ensure the manual hand dip and level verification procedures are being conducted correctly before enabling this correction method.
-  This mode cannot be used in conjunction with HTG because the level is not measured relative to the gauge reference height with HTG.

CTSh: Calculation of the wall temperature

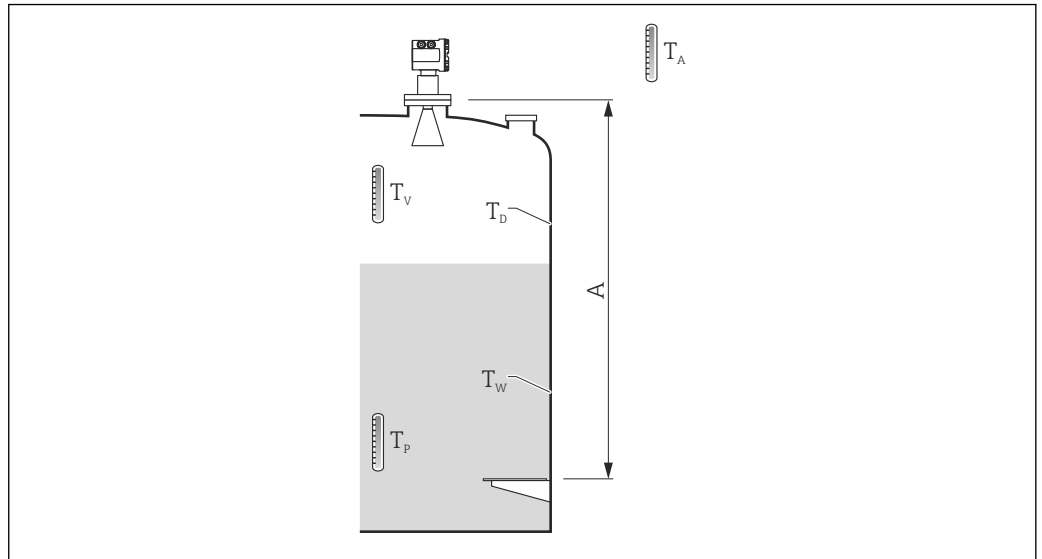

A0028714

53 Parameters for the CTSh calculation

A Gauge Reference Height (GRH)

T_W	Temperature of the wetted part of the tank shell
T_D	Temperature of the dry part of the tank shell
T_P	Product temperature
T_V	Vapor temperature (in the tank)
T_A	Ambient temperature (atmosphere surrounding the tank)

CTSh: Calculation of the wall temperature

Depending on the parameters **Covered tank** (→ 195) and **Stilling well** (→ 196), the temperatures T_W of the wetted and T_D of the dry part of the tank wall are calculated as follows:

Covered tank (→ 195)	Stilling well (→ 196)	T_W	T_D
Covered	Yes ¹⁾	T_P	T_V
	No	$(7/8) T_P + (1/8) T_A$	$(1/2) T_V + (1/2) T_A$
Open top	Yes	T_P	T_A
	No	$(7/8) T_P + (1/8) T_A$	T_A

1) This option is also valid for insulated tanks without a stilling well. This is due to the temperature inside and outside of the tank shell being the same due to the insulation of the tank.

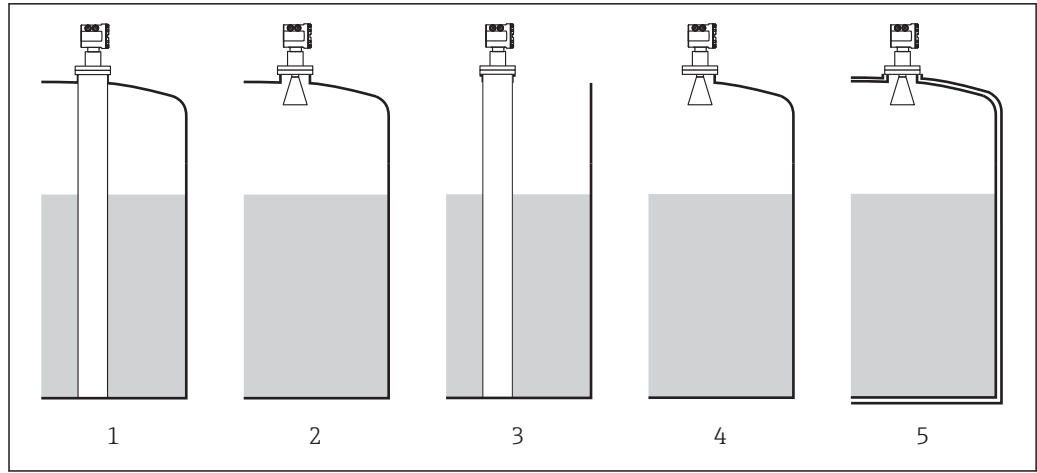

A0030381

- 1 Covered tank (→ 195) = Covered; Stilling well (→ 196) = Yes
- 2 Covered tank (→ 195) = Covered; Stilling well (→ 196) = No
- 3 Covered tank (→ 195) = Open top; Stilling well (→ 196) = Yes
- 4 Covered tank (→ 195) = Open top; Stilling well (→ 196) = No
- 5 Insulated tank: Covered tank (→ 195) = Open top; Stilling well (→ 196) = Yes

CTSh: Calculation of the correction

$$C_{CTSh} = \alpha (H - L)(T_D - T_{cal}) + \alpha L (T_W - T_{cal})$$

A0028716

H	Gauge Reference Height
L	Measured level
T_D	Temperature of the dry part of the tank shell (calculated from T _p , T _v and T _A)
T_W	Temperature of the wetted part of the tank shell (calculated from T _p , T _v and T _A)
T_{cal}	Temperature at which the measurement has been calibrated
α	Linear expansion coefficient
C_{CTSh}	CTSh correction value

Description of parameters

Navigation  Setup → Advanced setup → Application → Tank calculation → CTSh

CTSh correction value

Navigation  Setup → Advanced setup → Application → Tank calculation → CTSh → CTSh correction value

Description Shows the CTSh correction value.

Additional information

Read access	Operator
Write access	-

CTSh mode



Navigation  Setup → Advanced setup → Application → Tank calculation → CTSh → CTSh mode

Description Activates or deactivates the CTSh.

- Selection**
- No
 - Yes
 - With wire *
 - Only wire *

Factory setting No

Additional information

Read access	Operator
Write access	Maintenance

Covered tank



Navigation  Setup → Advanced setup → Application → Tank calculation → CTSh → Covered tank

Description Determines whether the tank is covered.

- Selection**
- Open top
 - Covered

Factory setting Open top

* Visibility depends on order options or device settings

Additional information

Read access	Operator
Write access	Maintenance

 The **Covered** option is only valid for fixed tank roofs. For a floating roof select **Open top**.

Stilling well**Navigation**

 Setup → Advanced setup → Application → Tank calculation → CTSh → Stilling well

Description

Determines whether the device is mounted on a stilling well.

Selection

- No
- Yes

Factory setting

No

Additional information

Read access	Operator
Write access	Maintenance

Calibration temperature**Navigation**

 Setup → Advanced setup → Application → Tank calculation → CTSh → Calibration temperature

Description

Specify temperature at which the measurement has been calibrated.

User entry

-50 to 250 °C

Factory setting

25 °C

Additional information

Read access	Operator
Write access	Maintenance

Linear expansion coefficient**Navigation**

 Setup → Advanced setup → Application → Tank calculation → CTSh → Linear expansion coefficient

Description

Defines the linear expansion coefficient of the tank shell material.

User entry

0 to 100 ppm

Factory setting

15 ppm

Additional information

Read access	Operator
Write access	Maintenance

Wire expansion coefficient



Navigation

Setup → Advanced setup → Application → Tank calculation → CTSh → Wire expansion coefficient

Description

Defines the expansion coefficient of the wire material of the drum. Value is programmed in factory.

User entry

0 to 100 ppm

Factory setting

15 ppm

*"HTG" submenu**Overview*

Hydrostatic Tank Gauging (HTG) is a method to calculate the level and the density of the product inside a tank using pressure measurements only. The pressure is measured at different heights of the tank using one, two or three pressure sensors. With these data either the density or the level of the product (or both) can be calculated.

HTG modes

Four HTG modes can be selected in the **HTG mode** parameter (\rightarrow  205). They determine which variables are measured and which are calculated. Depending on the selected mode a number of additional parameters are required for the calculation.

HTG mode (\rightarrow  205)	Measured variables	Required additional parameters	Calculated variables
P1 only	P1	<ul style="list-style-type: none"> ▪ ρ_P ▪ g ▪ H_{P1} 	L_{HTG}
P1 + P3	<ul style="list-style-type: none"> ▪ P1 ▪ P3 	<ul style="list-style-type: none"> ▪ ρ_P ▪ ρ_V ▪ ρ_A ▪ g ▪ H_{P1} ▪ H_{P3} 	L_{HTG} (more precise calculation for pressurized tanks)
P1 + P2	<ul style="list-style-type: none"> ▪ P1 ▪ P2 	<ul style="list-style-type: none"> ▪ ρ_A ▪ g ▪ H_{P1} ▪ H_{P1-P2} 	<ul style="list-style-type: none"> ▪ ρ_P ▪ L_{HTG}
P1 + P2 + P3	<ul style="list-style-type: none"> ▪ P1 ▪ P2 ▪ P3 	<ul style="list-style-type: none"> ▪ ρ_V ▪ ρ_A ▪ g ▪ H_{P1} ▪ H_{P1-P2} ▪ H_{P3} 	<ul style="list-style-type: none"> ▪ ρ_P ▪ L_{HTG} (more precise calculation for pressurized tanks)

HTG parameters

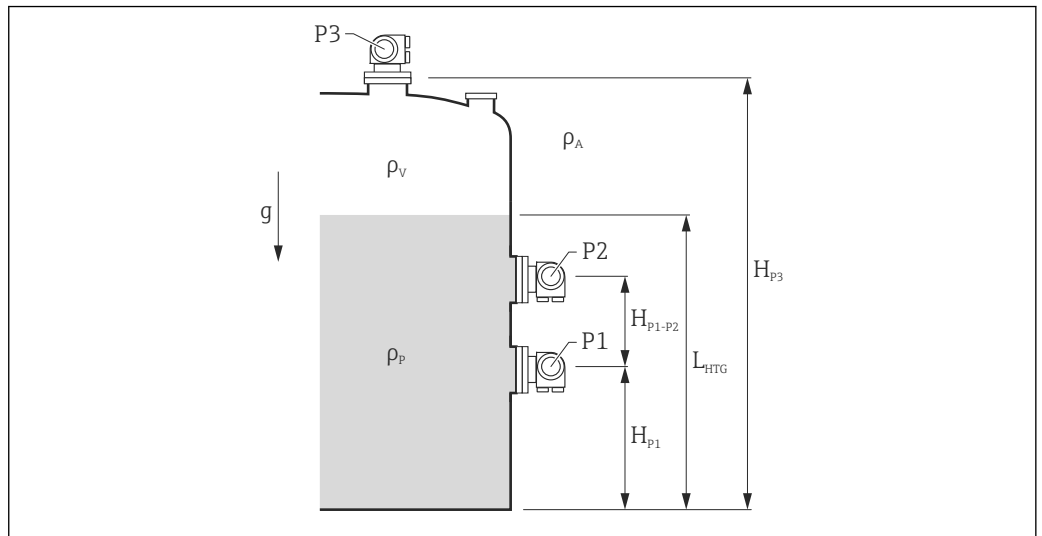

54 HTG parameters

A0028711

Parameter	Navigation path
P1 (Bottom pressure)	Setup → Advanced setup → Tank configuration → Pressure → P1 (bottom)
H_{p1} (Position of P1 transmitter)	Setup → Advanced setup → Tank configuration → Pressure → P1 position
P2 (Middle pressure)	Setup → Advanced setup → Tank configuration → Pressure → P2 (middle)
H_{p1-p2} (Distance between P1 and P2 transmitters)	Setup → Advanced setup → Tank configuration → Pressure → P1-2 distance
P3 (Top pressure)	Setup → Advanced setup → Tank configuration → Pressure → P3 (top)
H_{p3} (Position of P3 transmitter)	Setup → Advanced setup → Tank configuration → Pressure → P3 position
ρ_p (Density of the product ¹⁾)	<ul style="list-style-type: none"> ■ Read-only: Setup → Advanced setup → Calculation → HTG → Density value ■ Writable: Setup → Advanced setup → Calculation → HTG → Manual upper density
ρ_v (Vapor density)	Expert → Application → Tank configuration → Density → Vapor density
ρ_A (Ambient air temperature)	Setup → Advanced setup → Tank configuration → Density → Air density
g (Local gravity)	Expert → Application → Tank Calculation → Local gravity
L_{HTG} (Calculated level)	Setup → Advanced setup → Calculation → HTG → Tank level

1) Depending on the HTG mode parameter (→ 205) this is a writable or a read-only parameter.

HTG evaluation: dependence on measured level

To calculate the level or density by HTG with the required accuracy, P1 and P2 have to be covered by a certain product level. To avoid a measurement with an insufficient accuracy, the calculation will stop before the level reaches the position of the pressure sensor.

Two parameters are defined for this purpose:

▪ **Minimum level**

This parameter defines the position below which no level is accepted. If the calculation leads to **Tank level** < **Minimum level**, the value of **Minimum level** will be displayed instead of the calculated value.

▪ **Safety distance**

This parameter defines the minimum amount of product which must be present above the pressure sensor P1 or P2 for the level or density calculation to take place.



- The device always uses the bigger of these two values as the switch-over point for the level calculation.
- If **HTG mode** (→ 205) is set to **P1 only** or **P1 + P3**, the density is not calculated and the **Manual upper density** parameter is used instead.

Case 1: $H_{P1} < \text{Minimum level} < H_{P2}$

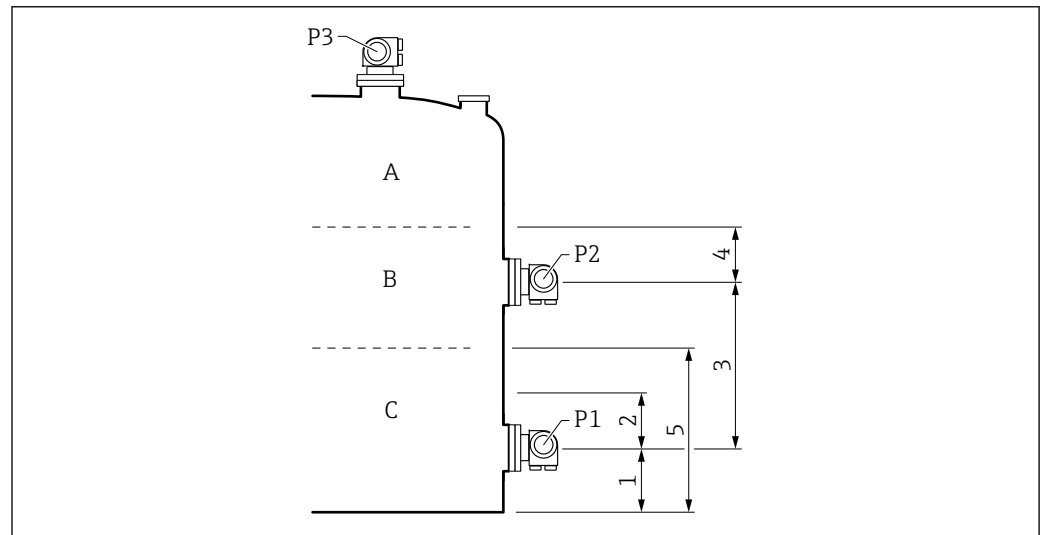

- 1 P1 position (→ 182)
- 2 Safety distance (→ 207)
- 3 P1-2 distance (→ 184)
- 4 Safety distance (→ 207)
- 5 Minimum level (→ 206)

Level L is in area	Calculation method for ρ_p	Calculation method for L
A	calculated from pressure	calculated from pressure
B	ρ_p held	calculated from pressure
C	ρ_p held	L = Minimum level

Case 2: Minimum level <math> < H_{P1}</math>

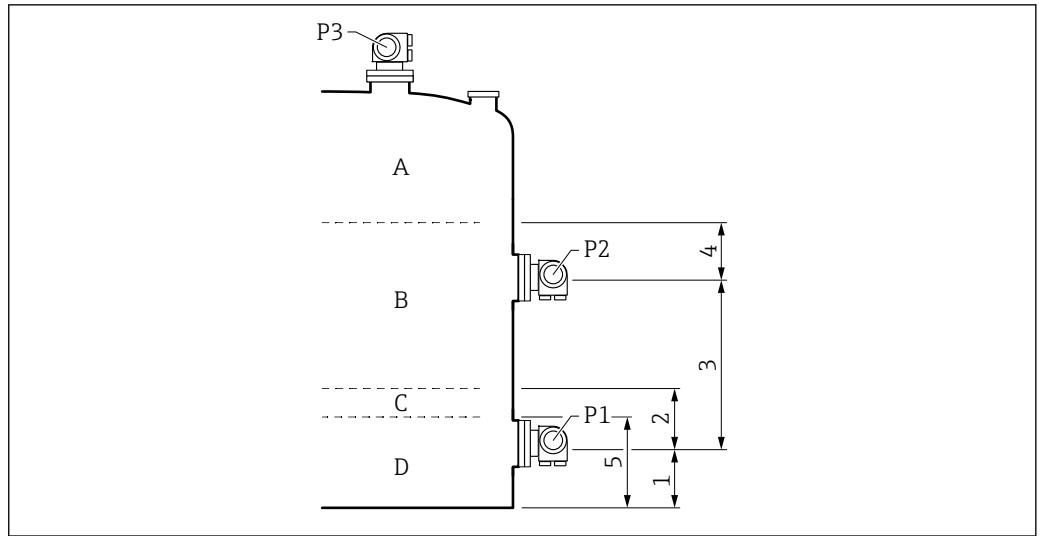

A0028719

- 1 P1 position (→ 182)
- 2 Safety distance (→ 207)
- 3 P1-2 distance (→ 184)
- 4 Safety distance (→ 207)
- 5 Minimum level (→ 206)

Level L is in area	Calculation method for ρ_p	Calculation method for L
A	calculated from pressure	calculated from pressure
B	ρ_p held	calculated from pressure
C/D	ρ_p held	L = Minimum level

Case 3: Minimum level > H_{P2}

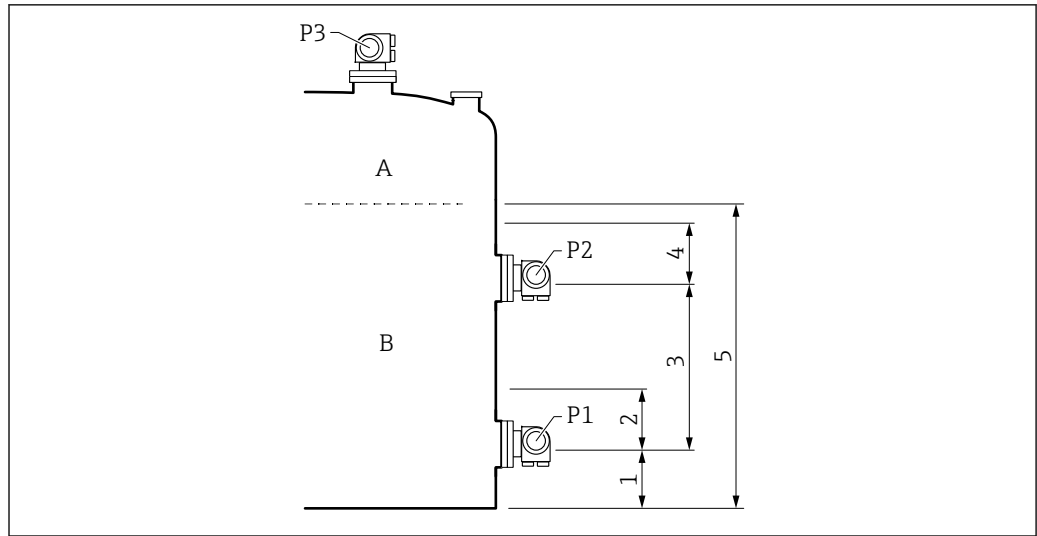



A0028717

- 1 P1 position (→ 182)
- 2 Safety distance (→ 207)
- 3 P1-2 distance (→ 184)
- 4 Safety distance (→ 207)
- 5 Minimum level (→ 206)

Level L is in area	Calculation method for ρ_p	Calculation method for L
A	calculated from pressure	calculated from pressure
B	ρ_p held	L = Minimum level

HTG evaluation: dependence on measured pressure

If the level of the product approaches the the P1 or P2 pressure sensor, the measured pressure becomes very small and the measurement might be too inaccurate for the Tank Gauging application. To solve this problem, a minimum pressure P_{\min} is defined in the **Minimum pressure** parameter (→  206). If the pressure measured by the sensor P1 or P2, respectively, the software stops calculating the density and either holds the last calculated value (for the density) or returns the HTMinLevel (for HTGLevel).

- If P2 is smaller than P_{\min} , the software stops calculating the density and uses the last density value.
- If P1 is smaller than P_{\min} , the software stops calculating the level and uses the value of **Minimum level** (→  206), instead.

Hysteresis

The level of the product in a tank is not constant but slightly varies, due for example to filling disturbances. If the level oscillates around the changeover level (**Minimum level**), the algorithm will constantly switch between calculating the value and holding the previous result. To avoid this effect a positional hysteresis is defined around the changeover point.

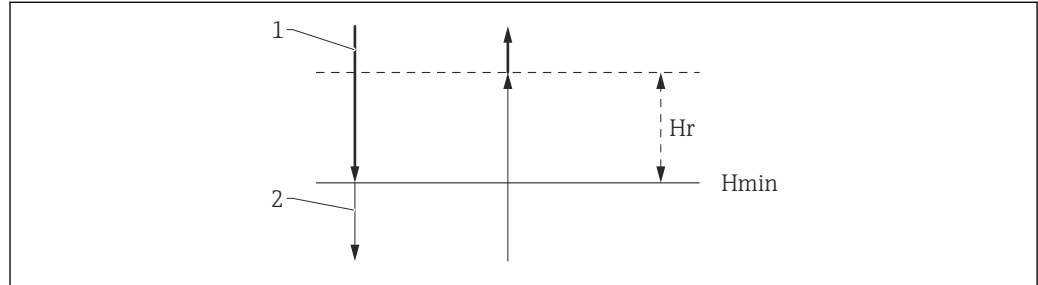

A0028720

55 HTG hysteresis

1 Value calculated

2 Value held/manual

H_{min} Minimum level

H_r Hysteresis (\rightarrow 207)

Description of parameters

Navigation  Setup → Advanced setup → Application → Tank calculation → HTG

Density value

Navigation  Setup → Advanced setup → Application → Tank calculation → HTG → Density value

Description Shows the density calculated by HTG.

Additional information

Read access	Operator
Write access	-

Tank level

Navigation  Setup → Advanced setup → Application → Tank calculation → HTG → Tank level

Description Shows the level calculated by HTG.

User interface Signed floating-point number

Factory setting 0 mm

Additional information

Read access	Operator
Write access	-

HTG mode

Navigation  Setup → Advanced setup → Application → Tank calculation → HTG → HTG mode

Description Defines the HTG mode.

Selection

- P1 only
- P1 + P3
- P1 + P2
- P1 + P2 + P3

Factory setting P1 only

Additional information

Read access	Operator
Write access	Maintenance

Manual density

Navigation Setup → Advanced setup → Application → Tank calculation → HTG → Manual density

Description Defines the manual density.

User entry 0 to 3 000 kg/m³

Factory setting 800 kg/m³

Additional information

Read access	Maintenance
Write access	Maintenance

Minimum level

Navigation Setup → Advanced setup → Application → Tank calculation → HTG → Minimum level

Description Defines the minimum level below which no HTG calculation will take place.

User entry 0 to 20 000 mm

Factory setting 7 000 mm

Additional information

Read access	Operator
Write access	Maintenance

Minimum pressure

Navigation Setup → Advanced setup → Application → Tank calculation → HTG → Minimum pressure

Description Defines the minimum pressure below which no HTG calculation takes place.

User entry 0 to 100 bar

Factory setting 0.1 bar

Additional information

Read access	Operator
Write access	Maintenance

Safety distance

Navigation  Setup → Advanced setup → Application → Tank calculation → HTG → Safety distance

Description Defines the minimum level which must be present above the bottom and middle pressure sensor before their signal is used for the calculation.

User entry 0 to 10 000 mm

Factory setting 2 000 mm

Additional information

Read access	Operator
Write access	Maintenance

Hysteresis

Navigation  Setup → Advanced setup → Application → Tank calculation → HTG → Hysteresis

Description Defines the hysteresis for the HTG calculation. Prevents constant switching if the level is near the switch-over point.

User entry 0 to 2 000 mm

Factory setting 50 mm

Additional information

Read access	Operator
Write access	Maintenance

"HTMS" submenu

Overview

The Hybrid Tank Measurement System (HTMS) is a method to calculate the density of a product in a tank based on both a (top mounted) level and at least one (bottom mounted) pressure measurement. An additional pressure sensor can be installed at the top of the tank to provide information about the vapor pressure and to make the density calculation more accurate. The calculation method also takes into account a possible level of water at the bottom of the tank to make density calculations as accurate as possible.

HTMS parameters

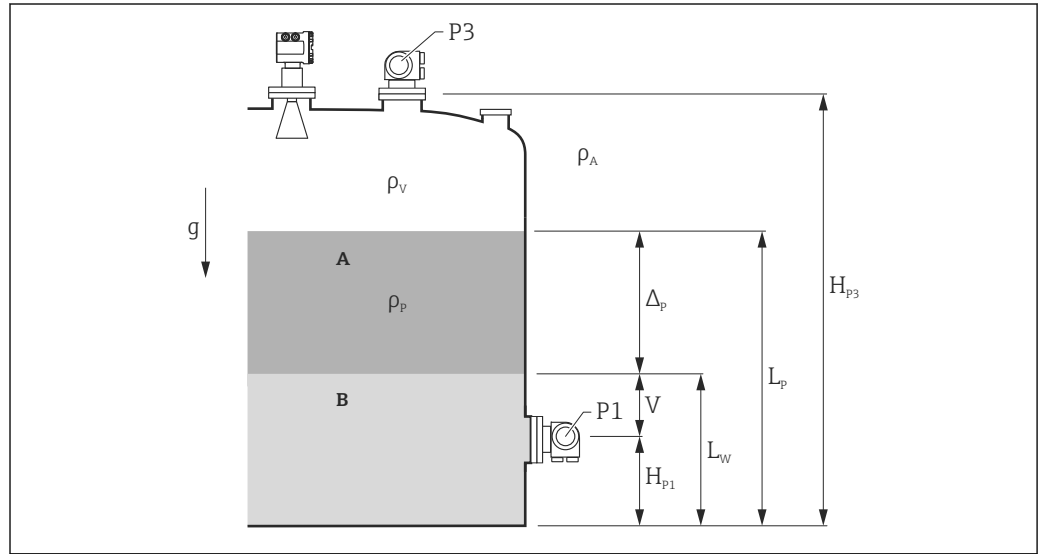

56 HTMS parameters

- A Product
- B Water

Parameter	Navigation path
P1 (Bottom pressure)	Setup → Advanced setup → Tank configuration → Pressure → P1 (bottom)
H _{P1} (Position of P1 transmitter)	Setup → Advanced setup → Tank configuration → Pressure → P1 position
P3 (Top pressure)	Setup → Advanced setup → Tank configuration → Pressure → P3 (top)
H _{P3} (Position of P3 transmitter)	Setup → Advanced setup → Tank configuration → Pressure → P3 position
ρ _p (Density of the product ¹⁾)	<ul style="list-style-type: none"> ■ Measured value: Setup → Advanced setup → Calculation → HTMS → Density value ■ User-defined value: Setup → Advanced setup → Calculation → HTMS → Manual upper density
ρ _v (Vapor density)	Expert → Application → Tank configuration → Density → Vapor density
ρ _A (Ambient air temperature)	Setup → Advanced setup → Tank configuration → Density → Air density
g (Local gravity)	Expert → Application → Tank Calculation → Local gravity
L _p (Level of the product)	Operation → Tank level
L _w (Bottom water level)	Operation → Water level
V = L _w - H _{P1}	
Δ _p = L _p - L _w = L _p - V - H _{P1}	

1) Depending on the situation this parameter is measured or a user-defined value is used.

HTMS modes

Two HTMS modes can be selected in the **HTMS mode** parameter (→  210). The mode determines whether one or two pressure values are used. Depending on the selected mode a number of additional parameters are required for the calculation of the product density.

 The **HTMS P1+P3** option must be used in pressurized tanks in order to compensate for the pressure of the vapor phase.

HTMS mode (→  210)	Measured variables	Required additional parameters	Calculated variables
HTMS P1	<ul style="list-style-type: none"> ▪ P₁ ▪ L_P 	<ul style="list-style-type: none"> ▪ g ▪ H_{P1} ▪ L_W (optional) 	ρ _P
HTMS P1+P3	<ul style="list-style-type: none"> ▪ P₁ ▪ P₃ ▪ L_P 	<ul style="list-style-type: none"> ▪ ρ_V ▪ ρ_A ▪ g ▪ H_{P1} ▪ H_{P3} ▪ L_W (optional) 	ρ _P (more precise calculation for pressurized tanks)

Minimum level

The density of the product can only be calculated if the product has a minimum thickness :

$$\Delta_p \geq \Delta_{p, \min}$$

A0028864

This is equivalent to the following condition for the product level:

$$L_p - V \geq \Delta_{p, \min} + H_{P1} = L_{\min}$$

A0028863

L_{min} is defined in the **Minimum level** parameter (→  211). As can be seen from the formula it always must be bigger than H_{P1}.

If L_p - V falls below this limit, the density is calculated as follows:

- If a previous calculated value is available, this value will be kept as long as no new calculation is possible.
- If no value was previously calculated, the manual value (defined in the **Manual upper density** parameter) will be used.

Hysteresis

The level of the product in a tank is not constant but slightly varies, due for example to filling disturbances. If the level oscillates around the changeover level (**Minimum level** (→  211)), the algorithm will constantly switch between calculating the value and holding the previous result. To avoid this effect a positional hysteresis is defined around the changeover point.

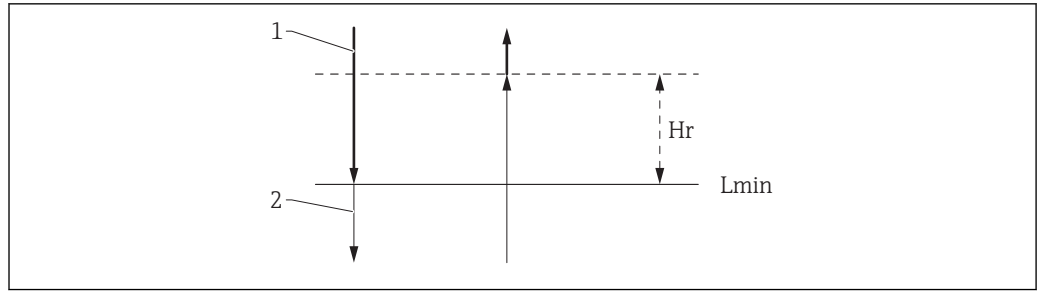

A0029148

57 HTMS hysteresis

- 1 Value calculated
- 2 Value held/manual
- L_{min} Minimum level (→ 211)
- H_r Hysteresis (→ 212)

Description of parameters

Navigation Setup → Advanced setup → Application → Tank calculation → HTMS

HTMS mode

Navigation	Setup → Advanced setup → Application → Tank calculation → HTMS → HTMS mode				
Description	Defines the HTMS mode. Depending on the mode one or two pressure transmitters are used.				
Selection	<ul style="list-style-type: none"> ■ HTMS P1 ■ HTMS P1+P3 				
Factory setting	HTMS P1				
Additional information	<table border="1" style="width: 100%; border-collapse: collapse;"> <tr> <td style="padding: 2px;">Read access</td> <td style="padding: 2px;">Operator</td> </tr> <tr> <td style="padding: 2px;">Write access</td> <td style="padding: 2px;">Maintenance</td> </tr> </table>	Read access	Operator	Write access	Maintenance
Read access	Operator				
Write access	Maintenance				

Meaning of the options

- HTMS P1
Only a bottom pressure transmitter (P1) is used.
- HTMS P1+P3
A bottom (P1) and top (P3) pressure transmitter are used. This option should be selected for pressurized tanks.

Manual density

Navigation	Setup → Advanced setup → Application → Tank calculation → HTMS → Manual density
Description	Defines the manual density.

User entry 0 to 3 000 kg/m³

Factory setting 800 kg/m³

Additional information

Read access	Maintenance
Write access	Maintenance

Density value

Navigation  Setup → Advanced setup → Application → Tank calculation → HTMS → Density value

Description Shows the calculated product density.

Additional information

Read access	Operator
Write access	-

Minimum level



Navigation  Setup → Advanced setup → Application → Tank calculation → HTMS → Minimum level

Description Defines the minimum product level for a HTMS calculation. If Lp - V falls below the limit defined in this parameter, the density retains its last value or the manual value is used instead.

User entry 0 to 20 000 mm

Factory setting 7 000 mm

Additional information

Read access	Operator
Write access	Maintenance

Minimum pressure



Navigation  Setup → Advanced setup → Application → Tank calculation → HTMS → Minimum pressure

Description Defines the minimum pressure for a HTMS calculation. If the pressure P1 (or the difference P1 - P3) falls below the limit defined in this parameter, the density retains its last value or the manual value is used instead.

User entry 0 to 100 bar

Factory setting 0.1 bar

Additional information

Read access	Operator
Write access	Maintenance

Safety distance**Navigation**

Setup → Advanced setup → Application → Tank calculation → HTMS → Safety distance

Description

Defines the minimum level which must be present above the bottom pressure sensor before its signal is used for the calculation.

User entry

0 to 10 000 mm

Factory setting

2 000 mm

Additional information

Read access	Operator
Write access	Maintenance

Hysteresis**Navigation**

Setup → Advanced setup → Application → Tank calculation → HTMS → Hysteresis

Description

Defines the hysteresis for the HTMS calculation. Prevents constant switching if the level is near the switch-over point.

User entry

0 to 2 000 mm

Factory setting

50 mm

Additional information

Read access	Operator
Write access	Maintenance

Water density**Navigation**

Setup → Advanced setup → Application → Tank calculation → HTMS → Water density

Description

Density of the water in the tank.

User entry

Signed floating-point number

Factory setting

1 000 kg/m³

Additional information

Read access	Operator
Write access	Maintenance

"Alarm" submenu

Navigation  Setup → Advanced setup → Application → Alarm → Alarm → Alarm mode

Alarm mode



Navigation  Setup → Advanced setup → Application → Alarm → Alarm → Alarm mode

Description Defines the alarm mode of the selected alarm.

- Selection**
- Off
 - On
 - Latching

Factory setting Off

Additional information

Read access	Operator
Write access	Maintenance

Meaning of the options

- **Off**
No alarms are generated.
- **On**
An alarm disappears if the alarm condition is no longer present (taking into consideration the hysteresis).
- **Latching**
All alarms remain active until the user selects **Clear alarm** (→  220) = **Yes** or the power is switched off and on.

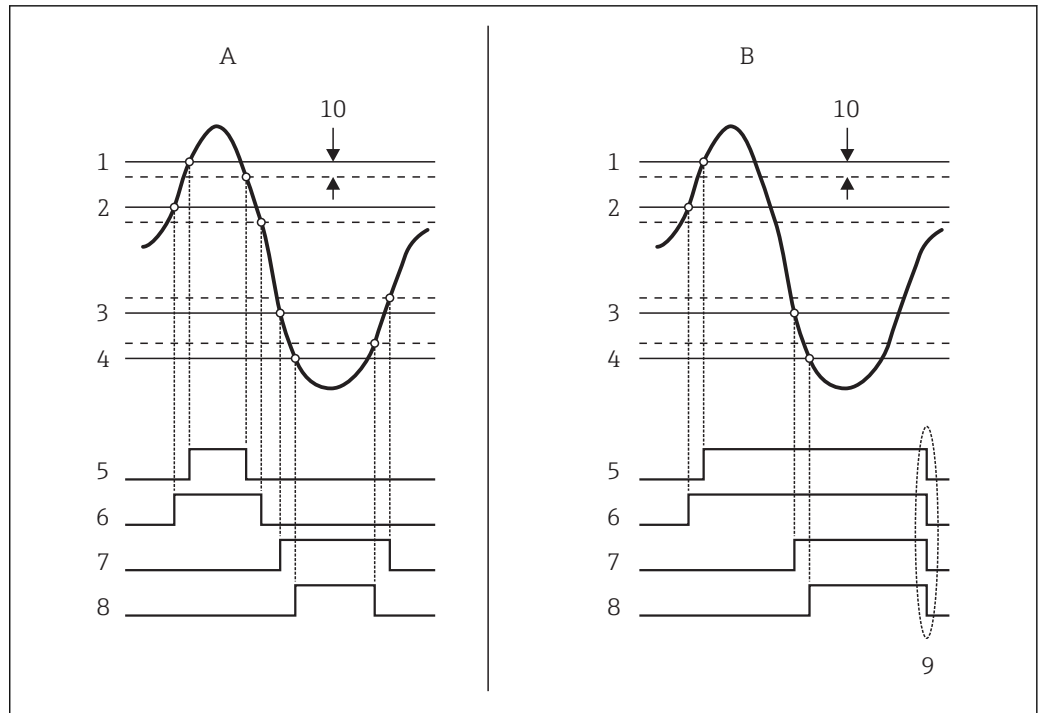

A0029539

58 Principle of the limit evaluation

- A Alarm mode (→ 214) = On
- B Alarm mode (→ 214) = Latching
- 1 HH alarm value (→ 217)
- 2 H alarm value (→ 217)
- 3 L alarm value (→ 218)
- 4 LL alarm value (→ 218)
- 5 HH alarm (→ 218)
- 6 H alarm (→ 219)
- 7 L alarm (→ 219)
- 8 LL alarm (→ 219)
- 9 "Clear alarm (→ 220)" = "Yes" or power off-on
- 10 Hysteresis (→ 221)

Error value



Navigation

Setup → Advanced setup → Application → Alarm → Alarm → Error value

Prerequisite

Alarm mode (→ 214) ≠ Off

Description

Defines the alarm to be issued if the input value is invalid.

Selection

- No alarm
- HH+H alarm
- H alarm
- L alarm
- LL+L alarm
- All alarms

Factory setting

All alarms

Additional information

Read access	Operator
Write access	Maintenance

Alarm value source



Navigation Setup → Advanced setup → Application → Alarm → Alarm → Alarm value source

Prerequisite **Alarm mode (→ 214) ≠ Off**

Description Determines the process variable to be monitored.

- Selection**
- Tank level
 - Liquid temperature
 - Vapor temperature
 - Water level
 - P1 (bottom)
 - P2 (middle)
 - P3 (top)
 - Observed density value
 - Volume
 - Flow velocity
 - Volume flow
 - Vapor density
 - Middle density
 - Upper density
 - Correction
 - Tank level %
 - GP 1...4 value
 - Measured level
 - P3 position
 - Tank reference height
 - Local gravity
 - P1 position
 - Manual density
 - Tank ullage
 - Average profile density
 - Lower density
 - Upper interface level
 - Lower interface level
 - Bottom level
 - Displacer position
 - HART device 1...15 PV
 - HART device 1...15 SV
 - HART device 1...15 TV
 - HART device 1...15 QV
 - HART device 1...15 PV mA
 - HART device 1...15 PV %
 - Element temperature 1...24
 - AIO B1-3 value
 - AIO C1-3 value
 - AIP B4-8 value
 - AIP C4-8 value
 - None

Factory setting None

Additional information

Read access	Operator
Write access	Maintenance

Alarm value

Navigation  Setup → Advanced setup → Application → Alarm → Alarm → Alarm value

Prerequisite **Alarm mode (→  214) ≠ Off**

Description Shows the current value of the process variable being monitored.

User interface Signed floating-point number

Factory setting 0 None

Additional information

Read access	Operator
Write access	-

HH alarm value



Navigation  Setup → Advanced setup → Application → Alarm → Alarm → HH alarm value

Prerequisite **Alarm mode (→  214) ≠ Off**

Description Defines the high-high(HH) limit value.

User entry Signed floating-point number

Factory setting 0 None

Additional information

Read access	Operator
Write access	Maintenance

H alarm value



Navigation  Setup → Advanced setup → Application → Alarm → Alarm → H alarm value

Prerequisite **Alarm mode (→  214) ≠ Off**

Description Defines the high(H) limit value.

User entry Signed floating-point number

Factory setting 0 None

Additional information

Read access	Operator
Write access	Maintenance

L alarm value

Navigation Setup → Advanced setup → Application → Alarm → Alarm → L alarm value

Prerequisite **Alarm mode (→ 214) ≠ Off**

Description Defines the low limit value.

User entry Signed floating-point number

Factory setting 0 None

Additional information

Read access	Operator
Write access	Maintenance

LL alarm value

Navigation Setup → Advanced setup → Application → Alarm → Alarm → LL alarm value

Prerequisite **Alarm mode (→ 214) ≠ Off**

Description Defines the low-low(LL) limit value.

User entry Signed floating-point number

Factory setting 0 None

Additional information

Read access	Operator
Write access	Maintenance

HH alarm

Navigation Setup → Advanced setup → Application → Alarm → Alarm → HH alarm



Prerequisite **Alarm mode (→ 214) ≠ Off**

Description Shows whether an HH alarm is currently active.

Additional information

Read access	Operator
Write access	-

H alarm

Navigation   Setup → Advanced setup → Application → Alarm → Alarm → H alarm



Prerequisite **Alarm mode (→  214) ≠ Off**

Description Shows whether an H alarm is currently active.

Additional information

Read access	Operator
Write access	-

HH+H alarm

Navigation   Setup → Advanced setup → Application → Alarm → Alarm → HH+H alarm

Prerequisite **Alarm mode (→  214) ≠ Off**

Description Shows whether an HH or H alarm is currently active.

Additional information

Read access	Operator
Write access	-

L alarm

Navigation   Setup → Advanced setup → Application → Alarm → Alarm → L alarm

Prerequisite **Alarm mode (→  214) ≠ Off**

Description Shows whether an L alarm is currently active.

Additional information

Read access	Operator
Write access	-

LL alarm

Navigation   Setup → Advanced setup → Application → Alarm → Alarm → LL alarm

Prerequisite **Alarm mode (→  214) ≠ Off**

Description Shows whether an LL alarm is currently active.

Additional information

Read access	Operator
Write access	-

LL+L alarm

Navigation

 Setup → Advanced setup → Application → Alarm → Alarm → LL+L alarm

Prerequisite

Alarm mode (→  214) ≠ Off

Description

Shows whether an LL or L alarm is currently active.

Additional information

Read access	Operator
Write access	-

Any error

Navigation

 Setup → Advanced setup → Application → Alarm → Alarm → Any error

Prerequisite

Alarm mode (→  214) ≠ Off

Description

Show whether any alarm is currently active.

User interface

- Unknown
- Inactive
- Active
- Error

Factory setting

Unknown

Additional information

Read access	Operator
Write access	-

Clear alarm



Navigation

 Setup → Advanced setup → Application → Alarm → Alarm → Clear alarm

Prerequisite

Alarm mode (→  214) = Latching

Description

Deletes an alarm which is still active although the alarm condition is no longer present.

Selection

- No
- Yes

Factory setting

No

Additional information

Read access	Operator
Write access	Maintenance

Alarm hysteresis



Navigation

Setup → Advanced setup → Application → Alarm → Alarm → Alarm hysteresis

Prerequisite

Alarm mode (→ 214) ≠ Off

Description

Defines the hysteresis for the limit values. The hysteresis prevents constant changes of the alarm state if the level is near one of the limit values.

User entry

Signed floating-point number

Factory setting

0.001

Additional information

Read access	Maintenance
Write access	Maintenance

Damping factor



Navigation

Setup → Advanced setup → Application → Alarm → Alarm → Damping factor

Description

Defines the damping constant (in seconds).

User entry

0 to 999.9 s

Factory setting

0 s

Additional information

Read access	Operator
Write access	Maintenance

"Display" submenu

This menu is only visible if the device has a local display.

Navigation  Setup → Advanced setup → Display

Language

Navigation  Setup → Advanced setup → Display → Language

Prerequisite The device has a local display.

Description Set display language.

- Selection**
- English
 - Deutsch *
 - Français *
 - Español *
 - Italiano *
 - Nederlands *
 - Portuguesa *
 - Polski *
 - русский язык (Russian) *
 - Svenska *
 - Türkçe *
 - 中文 (Chinese) *
 - 日本語 (Japanese) *
 - 한국어 (Korean) *
 - العربية (Arabic) *
 - Bahasa Indonesia *
 - ภาษาไทย (Thai) *
 - tiếng Việt (Vietnamese) *
 - čeština (Czech) *

Factory setting English

Additional information

Read access	Operator
Write access	Operator

Format display

Navigation  Setup → Advanced setup → Display → Format display

Prerequisite The device has a local display.

Description Select how measured values are shown on the display.



* Visibility depends on order options or device settings

- Selection**
- 1 value, max. size
 - 1 bargraph + 1 value
 - 2 values
 - 1 value large + 2 values
 - 4 values

Factory setting 1 value, max. size



Additional information

Read access	Operator
Write access	Operator

- The **Value 1 to 4 display** (→  223) parameters specify which measured values are shown on the display and in which order.
- If more measured values are specified than the current display mode permits, the values alternate on the device display. The display time until the next change is configured in the **Display interval** parameter (→  226).

Value 1 to 4 display



Navigation   Setup → Advanced setup → Display → Value 1 display

Prerequisite The device has a local display.

Description Select the measured value that is shown on the local display.

- Selection**
- None ⁸⁾
 - Tank level
 - Measured level
 - Tank level %
 - Water level ⁸⁾
 - Liquid temperature ⁸⁾
 - Vapor temperature ⁸⁾
 - Air temperature ⁸⁾
 - Tank ullage
 - Tank ullage %
 - Observed density value ⁸⁾
 - P1 (bottom) ⁸⁾
 - P2 (middle) ⁸⁾
 - P3 (top) ⁸⁾
 - GP 1 value ⁸⁾
 - GP 2 value ⁸⁾
 - GP 3 value ⁸⁾
 - GP 4 value ⁸⁾
 - Gauge command ⁸⁾
 - Gauge status ⁸⁾
 - AIO B1-3 value ⁸⁾
 - AIO B1-3 value mA ⁸⁾
 - AIO B1-3 value % ⁸⁾
 - AIO C1-3 value ⁸⁾
 - AIO C1-3 value mA ⁸⁾
 - AIO C1-3 value % ⁸⁾

8) not available for the **Value 1 display** parameter



- AIP B4-8 value ⁸⁾
- AIP B4-8 value mA ⁸⁾
- AIP B4-8 value % ⁸⁾
- AIP C4-8 value ⁸⁾
- AIP C4-8 value mA ⁸⁾
- AIP C4-8 value % ⁸⁾

Factory setting Depending on device version

Additional information

Read access	Operator
Write access	Maintenance

Decimal places 1 to 4 

Navigation   Setup → Advanced setup → Display → Decimal places 1

Prerequisite The device has a local display.

Description This selection does not affect the measurement and calculation accuracy of the device.



- Selection**
- X
 - X.X
 - X.XX
 - X.XXX
 - X.XXXX

Factory setting x.x

Additional information

Read access	Operator
Write access	Maintenance

Separator 

Navigation   Setup → Advanced setup → Display → Separator

Prerequisite The device has a local display.

Description Select decimal separator for displaying numerical values.

- Selection**
- .
 - ,

Factory setting .

Additional information

Read access	Operator
Write access	Maintenance

Number format

Navigation Setup → Advanced setup → Display → Number format

Prerequisite The device has a local display.

Description Choose number format for the display.

Selection

- Decimal
- ft-in-1/16"

Factory setting Decimal

Additional information

Read access	Operator
Write access	Maintenance

The **ft-in-1/16"** option is only valid for distance values.

Header

Navigation Setup → Advanced setup → Display → Header

Prerequisite The device has a local display.

Description Select header contents on local display.

Selection

- Device tag
- Free text

Factory setting Device tag

Additional information

Read access	Operator
Write access	Maintenance

Meaning of the options

- **Device tag**
The header contents is defined in the **Device tag** parameter (→ 240).
- **Free text**
The header contents is defined in the **Header text** parameter (→ 225).

Header text

Navigation Setup → Advanced setup → Display → Header text

Prerequisite **Header** (→ 225) = **Free text**



Description Enter display header text.

Factory setting TG-Platform

Additional information

Read access	Operator
Write access	Maintenance

Display interval

Navigation   Setup → Advanced setup → Display → Display interval

Description Set time measured values are shown on display if display alternates between values.



User entry 1 to 10 s

Factory setting 5 s

Additional information

Read access	Operator
Write access	Operator

Display damping

Navigation   Setup → Advanced setup → Display → Display damping

Prerequisite The device has a local display.

Description Set display reaction time to fluctuations in the measured value.



User entry 0.0 to 999.9 s

Factory setting 0.0 s

Additional information

Read access	Operator
Write access	Maintenance

Backlight

Navigation   Setup → Advanced setup → Display → Backlight

Prerequisite The device has a local display.

Description Switch the local display backlight on and off.

Selection ▪ Disable
 ▪ Enable

Factory setting Enable

Additional information

Read access	Operator
Write access	Operator

Contrast display

Navigation  Setup → Advanced setup → Display → Contrast display

Prerequisite The device has a local display.

Description Adjust local display contrast setting to ambient conditions (e.g. lighting or reading angle).

User entry 20 to 80 %

Factory setting 30 %

Additional information

Read access	Operator
Write access	Operator

"System units" submenu

Navigation  Setup → Advanced setup → System units

Units preset 

Navigation  Setup → Advanced setup → System units → Units preset

Description Defines a set of units for length, pressure and temperature.





- Selection**
- mm, bar, °C
 - m, bar, °C
 - mm, PSI, °C
 - ft, PSI, °F
 - ft-in-16, PSI, °F
 - ft-in-8, PSI, °F
 - Customer value

Factory setting mm, bar, °C

Additional information

Read access	Operator
Write access	Maintenance

If the **Customer value** option is selected, the units are defined in the following parameters:

- Distance unit (→  228)
- Pressure unit (→  229)
- Temperature unit (→  229)
- Density unit (→  229)

In any other case these are read-only parameters used to indicate the respective unit.

Distance unit 

Navigation  Setup → Advanced setup → System units → Distance unit

Description Select distance unit.

- Selection**
- | | |
|--|--|
| <p><i>SI units</i></p> <ul style="list-style-type: none"> ■ m ■ mm ■ cm | <p><i>US units</i></p> <ul style="list-style-type: none"> ■ ft ■ in ■ ft-in-16 ■ ft-in-8 |
|--|--|

Factory setting mm

Additional information

Read access	Operator
Write access	Maintenance (if Units preset (→  121) = Customer value)

Pressure unit



Navigation Setup → Advanced setup → System units → Pressure unit

Description Select process pressure unit.

Selection

<p><i>SI units</i></p> <ul style="list-style-type: none"> ■ bar ■ Pa ■ kPa ■ MPa ■ mbar a 	<p><i>US units</i></p> <ul style="list-style-type: none"> psi 	<p><i>Other units</i></p> <ul style="list-style-type: none"> ■ inH2O ■ inH2O (68°F) ■ ftH2O (68°F) ■ mmH2O ■ mmHg
--	--	--

Factory setting bar

Additional information

Read access	Operator
Write access	Maintenance (if Units preset (→ 121) = Customer value)

Temperature unit



Navigation Setup → Advanced setup → System units → Temperature unit

Description Select temperature unit.

Selection

<p><i>SI units</i></p> <ul style="list-style-type: none"> ■ °C ■ K 	<p><i>US units</i></p> <ul style="list-style-type: none"> ■ °F ■ °R
--	---

Factory setting °C

Additional information

Read access	Operator
Write access	Maintenance (if Units preset (→ 121) = Customer value)

Density unit



Navigation Setup → Advanced setup → System units → Density unit

Description Select density unit.

Selection

<p><i>SI units</i></p> <ul style="list-style-type: none"> ■ g/cm³ ■ g/ml ■ g/l ■ kg/l ■ kg/dm³ ■ kg/m³ 	<p><i>US units</i></p> <ul style="list-style-type: none"> ■ lb/ft³ ■ lb/gal (us) ■ lb/in³ ■ STon/yd³ 	<p><i>Other units</i></p> <ul style="list-style-type: none"> ■ °API ■ SGU
---	---	---

Factory setting kg/m³

Additional information

Read access	Operator
Write access	Maintenance (if Units preset (→  121) = Customer value)

"Date / time" submenu

Navigation  Setup → Advanced setup → Date / time

Date/time

Navigation  Setup → Advanced setup → Date / time → Date/time

Description Displays the device internal real time clock.

Additional information

Read access	Operator
Write access	-

Set date



Navigation  Setup → Advanced setup → Date / time → Set date

Description Controls the setting of the real-time clock.

Selection

- Please select
- Abort
- Start
- Confirm time

Factory setting Please select

Additional information

Read access	Operator
Write access	Maintenance

Meaning of the options

- **Please select**
Prompts the user to select an action.
- **Abort**
Discards the entered date and time.
- **Start**
Starts the setting of the real time clock.
- **Confirm time**
Sets the real-time clock to the entered date and time.

Year



Navigation  Setup → Advanced setup → Date / time → Year

Prerequisite Set date (→  231) = Start

Description Enter the current year.

User entry 2 016 to 2 079

Factory setting 2 016

Additional information

Read access	Operator
Write access	Maintenance

Month 

Navigation  Setup → Advanced setup → Date / time → Month

Prerequisite **Set date (→  231) = Start**

Description Enter the current month.

User entry 1 to 12

Factory setting 1

Additional information

Read access	Operator
Write access	Maintenance

Day 

Navigation  Setup → Advanced setup → Date / time → Day

Prerequisite **Set date (→  231) = Start**

Description Enter the current day.

User entry 1 to 31

Factory setting 1

Additional information

Read access	Operator
Write access	Maintenance

Hour 

Navigation  Setup → Advanced setup → Date / time → Hour

Prerequisite **Set date (→  231) = Start**

Description Enter the current hour.

User entry 0 to 23

Factory setting 0

Additional information

Read access	Operator
Write access	Maintenance

Minute



Navigation Setup → Advanced setup → Date / time → Minute

Prerequisite Set date (→ 231) = Start

Description Enter the current minute.

User entry 0 to 59

Factory setting 0

Additional information

Read access	Operator
Write access	Maintenance

"SIL confirmation" wizard

-  The **SIL confirmation** wizard is only available for devices with SIL or WHG approval (Feature 590: "Additional Approval", option LA: "SIL" or LC: "WHG overflow prevention") which are currently **not** in the SIL- or WHG-locked state.
- The **SIL confirmation** wizard is required to lock the device according to SIL or WHG. For details refer to the "Functional Safety Manual" of the respective device, which describes the locking procedure and the parameters of this wizard.

Navigation  Setup → Advanced setup → SIL confirmation

"Deactivate SIL/WHG" wizard

-  The **Deactivate SIL/WHG** wizard is only available for devices with SIL or WHG approval (Feature 590: "Additional Approval", option LA: "SIL" or LC: "WHG overflow prevention") which are currently in the SIL- or WHG-locked state.
- The **Deactivate SIL/WHG** wizard is required to undo the locking of the device according to SIL or WHG. For details refer to the "Functional Safety Manual" of the respective device, which describes the locking procedure and the parameters of this wizard.

Navigation  Setup → Advanced setup → Deactivate SIL/WHG

"Administration" submenu

Navigation  Setup → Advanced setup → Administration

Define access code 

Navigation  Setup → Advanced setup → Administration → Define access code

Description Define release code for write access to parameters.

User entry 0 to 9999

Factory setting 0

Additional information

Read access	Operator
Write access	Maintenance

 If the factory setting is not changed or 0 is defined as the access code, the parameters are not write-protected and the configuration data of the device can then always be modified. The user is logged on in the *Maintenance* role.

 The write protection affects all parameters marked with the  symbol in this document.

 Once the access code has been defined, write-protected parameters can only be modified if the access code is entered in the **Enter access code** parameter.

Device reset 

Navigation   Setup → Advanced setup → Administration → Device reset

Description Reset the device configuration - either entirely or in part - to a defined state.

Selection

- Cancel
- To fieldbus defaults **
- To factory defaults *
- Restart device

Factory setting Cancel

Additional information

Read access	Operator
Write access	Maintenance

** Visibility depends on communication

* Visibility depends on order options or device settings

15.4 "Diagnostics" menu

Navigation  Diagnostics

Actual diagnostics

Navigation  Diagnostics → Actual diagnostics

Description Shows the current occurred diagnostic event along with its diagnostic information.



Additional information

Read access	Operator
Write access	-

The display consists of:

- Symbol for event behavior
- Code for diagnostic behavior
- Operating time of occurrence
- Event text

 If several messages are active at the same time, the messages with the highest priority is displayed.

 Information on what is causing the message, and remedy measures, can be viewed via the  symbol on the display.

Timestamp

Navigation  Diagnostics → Timestamp

Description Displays the timestamp for the currently active diagnostic message.

Additional information

Read access	Operator
Write access	-

Previous diagnostics

Navigation  Diagnostics → Previous diagnostics

Description Shows the diagnostic event that occurred prior to the current diagnostic event along with its diagnostic information.

Additional information

Read access	Operator
Write access	-

The display consists of:

- Symbol for event behavior
- Code for diagnostic behavior
- Operating time of occurrence
- Event text

 If several messages are active at the same time, the messages with the highest priority is displayed.

 Information on what is causing the message, and remedy measures, can be viewed via the ⓘ symbol on the display.

Timestamp

Navigation  Diagnostics → Timestamp

Description Shows the timestamp of the previous diagnostic message.

Additional information

Read access	Operator
Write access	-

Operating time from restart

Navigation  Diagnostics → Operating time from restart

Description Shows the time the device has been in operation since the last device restart.

Additional information

Read access	Operator
Write access	-

Operating time

Navigation  Diagnostics → Operating time

Description Indicates how long the device has been in operation.

Additional information

Read access	Operator
Write access	-

Date/time

Navigation Diagnostics → Date/time**Description**

Displays the device internal real time clock.



Additional information

Read access	Operator
Write access	-

15.4.1 "Diagnostic list" submenu

Navigation   Diagnostics → Diagnostic list

Diagnostics 1 to 5

Navigation	  Diagnostics → Diagnostic list → Diagnostics 1 to 5
Description	Display the current diagnostics messages with the highest to fifth-highest priority.
Additional information	The display consists of: <ul style="list-style-type: none">■ Symbol for event behavior■ Code for diagnostic behavior■ Operating time of occurrence■ Event text

Timestamp 1 to 5

Navigation	 Diagnostics → Diagnostic list → Timestamp
Description	Timestamp of the diagnostic message.

15.4.2 "Device information" submenu

Navigation  Diagnostics → Device information

Device tag

Navigation  Diagnostics → Device information → Device tag

Description Shows the device tag.

Factory setting NMS8x

Additional information

Read access	Operator
Write access	-

Serial number

Navigation  Diagnostics → Device information → Serial number

Description Shows the serial number of the measuring device.

Additional information

Read access	Operator
Write access	-

Firmware version

Navigation  Diagnostics → Device information → Firmware version

Description Shows the device firmware version installed.

Additional information

Read access	Operator
Write access	-

Firmware CRC

Navigation  Diagnostics → Device information → Firmware CRC

Description Result of the cyclic redundancy check of the firmware.

Additional information

Read access	Operator
Write access	-

Weight and measures configuration CRC**Navigation**

 Diagnostics → Device information → Weight and measures configuration CRC

Description

Result of the cyclic redundancy check of the weights and measure relevant parameters.

Additional information

Read access	Operator
Write access	-

Device name**Navigation**

 Diagnostics → Device information → Device name

Description

Shows the name of the transmitter.

Additional information

Read access	Operator
Write access	-

Order code**Navigation**

 Diagnostics → Device information → Order code

Description

Shows the device order code.

Additional information

Read access	Operator
Write access	Service

Extended order code 1 to 3**Navigation**

 Diagnostics → Device information → Extended order code 1

Description

Display the three parts of the extended order code.

Additional information

Read access	Operator
Write access	Service

The extended order code indicates the selected option of all ordering features and thus uniquely identifies the device.

15.4.3 "Simulation" submenu

Read access	Maintenance
-------------	-------------

Navigation  Diagnostics → Simulation

Device alarm simulation

Navigation   Diagnostics → Simulation → Device alarm simulation

Description Switch the device alarm on and off.



Selection

- Off
- On

Factory setting Off

Additional information	Read access	Operator
	Write access	Maintenance

Diagnostic event simulation

Navigation   Diagnostics → Simulation → Diagnostic event simulation

Description Select a diagnostic event to simulate this event.



Selection The diagnostic events of the device



Factory setting Off

Additional information	Read access	Operator
	Write access	Maintenance

 To terminate the simulation, select **Off**.

Current output simulation

Navigation   Diagnostics → Simulation → Current output 1 simulation

  Diagnostics → Simulation → Current output 2 simulation

Prerequisite

- The device has an Anlog I/O module.
- Operating mode (→  138) = 4..20mA output or HART slave +4..20mA output

Description Switches the simulation of the current on or off.

Selection



- Off
- On



Factory setting Off

Additional information

Read access	Operator
Write access	Maintenance

Simulation value

Navigation   Diagnostics → Simulation → Simulation value

  Diagnostics → Simulation → Simulation value

Prerequisite **Current output simulation (→  243) = On**

Description Defines the current to be simulated.

User entry 3.4 to 23 mA

Factory setting The current at the time the simulation was started.

Additional information

Read access	Operator
Write access	Maintenance

Index

Symbols

#blank# (Parameter) 127, 128

0 ... 9

0 % value (Parameter) 134, 142, 164
100 % value (Parameter) 134, 143, 164

A

Access status tooling (Parameter) 124
Accessories
 Communication specific 103
 Service specific 103
Actual diagnostics (Parameter) 236
Administration (Submenu) 235
Advanced setup (Submenu) 124
Air density (Parameter) 116, 179
Air temperature (Parameter) 114, 177
Air temperature source (Parameter) 176
Alarm (Submenu) 214
Alarm 1 input source (Parameter) 160
Alarm 2 input source (Parameter) 160
Alarm hysteresis (Parameter) 221
Alarm mode (Parameter) 214
Alarm value (Parameter) 217
Alarm value source (Parameter) 216
Ambient pressure (Parameter) 187
Analog I/O (Submenu) 138
Analog input 0% value (Parameter) 144
Analog input 100% value (Parameter) 144
Analog input source (Parameter) 140
Analog IP (Submenu) 132
Any error (Parameter) 220
Application 10
Application (Submenu) 172
Assign PV (Parameter) 163
Assign QV (Parameter) 168
Assign SV (Parameter) 165
Assign TV (Parameter) 167

B

Backlight (Parameter) 226
Baudrate (Parameter) 154
Bus termination (Parameter) 155

C

Calibration temperature (Parameter) 196
CE mark 11
Cleaning
 Exterior cleaning 99
Clear alarm (Parameter) 220
Communication (Submenu) 153
Communication interface protocol (Parameter) 153
Communication interface protocol variant (Parameter) 157
Communication status (Parameter) 127
Configuration (Submenu) 154, 157, 162
Contact type (Parameter) 150

Contrast display (Parameter) 227
Covered tank (Parameter) 195
CTSh (Submenu) 195
CTSh correction value (Parameter) 195
CTSh mode (Parameter) 195
Current output 1 simulation (Parameter) 243
Current output 2 simulation (Parameter) 243
Current span (Parameter) 139

D

Damping factor (Parameter) 136, 146, 221
Date / time (Submenu) 231
Date/time (Parameter) 231, 238
Day (Parameter) 232
DD 54
Deactivate SIL/WHG (Wizard) 234
Decimal places 1 (Parameter) 224
Declaration of Conformity 11
Define access code (Parameter) 235
Deformation factor (Parameter) 191
Density (Submenu) 116, 179
Density unit (Parameter) 229
Density value (Parameter) 205, 211
Designated use 10
Device alarm simulation (Parameter) 243
Device Descriptions 54
Device ID (Parameter) 155
Device information (Submenu) 240
Device name (Parameter) 126, 241
Device replacement 100
Device reset (Parameter) 235
Device tag (Parameter) 121, 126, 170, 240
Diagnostic event simulation (Parameter) 243
Diagnostic events 86
Diagnostic information
 FieldCare 89
Diagnostic list 97
Diagnostic list (Submenu) 239
Diagnostic message 86
Diagnostics
 Symbols 86
Diagnostics (Menu) 236
Diagnostics 1 to 5 (Parameter) 239
Diagnostics event 87
Digital input source (Parameter) 149
Digital Xx-x (Submenu) 148
DIP switch
 see Write protection switch
Display (Submenu) 222
Display damping (Parameter) 226
Display interval (Parameter) 226
Disposal 101
Distance unit (Parameter) 228
Document
 Function 4
Document function 4

E

Element position (Submenu)	115
Element position 1 to 24 (Parameter)	115
Element temperature (Submenu)	115
Element temperature 1 to 24 (Parameter)	115
Endress+Hauser services	
Maintenance	99
Repair	101
Enter access code (Parameter)	124
Error event type (Parameter)	145
Error value (Parameter)	142, 215
Event level	
Explanation	86
Symbols	86
Event text	87
Expected SIL/WHG chain (Parameter)	147
Extended order code 1 (Parameter)	241
Exterior cleaning	99

F

Failure mode (Parameter)	141
Firmware CRC (Parameter)	240
Firmware version (Parameter)	240
Fixed current (Parameter)	140
Float swap mode (Parameter)	155
Forget device (Parameter)	131
Forget device (Wizard)	131
Format display (Parameter)	222

G

Gauge current (Parameter)	137
GP 1 name (Parameter)	119
GP Value 1 (Parameter)	119
GP Value 2 (Parameter)	119
GP Value 3 (Parameter)	119
GP Value 4 (Parameter)	120
GP values (Submenu)	119

H

H alarm (Parameter)	219
H alarm value (Parameter)	217
Hardware write protection	48
HART date code (Parameter)	171
HART descriptor (Parameter)	170
HART Device(s) (Submenu)	126
HART devices (Submenu)	125
HART message (Parameter)	171
HART output (Submenu)	162
HART short tag (Parameter)	170
Header (Parameter)	225
Header text (Parameter)	225
HH alarm (Parameter)	218
HH alarm value (Parameter)	217
HH+H alarm (Parameter)	219
Hour (Parameter)	232
HTG (Submenu)	205
HTG mode (Parameter)	205
HTMS (Submenu)	210
HTMS mode (Parameter)	210

Hysteresis (Parameter)	207, 212
HyTD (Submenu)	190
HyTD correction value (Parameter)	190
HyTD mode (Parameter)	190

I

Information (Submenu)	170
Input value (Parameter)	135, 142, 150
Input value % (Parameter)	143
Input value in mA (Parameter)	145
Input value percent (Parameter)	146
Input/output (Submenu)	125

L

L alarm (Parameter)	219
L alarm value (Parameter)	218
Language (Parameter)	222
Level (Submenu)	112, 172
Level mapping (Parameter)	158
Level source (Parameter)	122, 172
Line impedance (Parameter)	159
Linear expansion coefficient (Parameter)	196
Liquid temp source (Parameter)	123, 175
Liquid temperature (Parameter)	114, 176
LL alarm (Parameter)	219
LL alarm value (Parameter)	218
LL+L alarm (Parameter)	220
Local display	
see Diagnostics message	
see In alarm condition	
Locking status (Parameter)	124
Lower interface level (Parameter)	113

M

Maintenance	99
Manual air temperature (Parameter)	176
Manual density (Parameter)	206, 210
Manual liquid temperature (Parameter)	175
Manual vapor temperature (Parameter)	177
Manual water level (Parameter)	174
Maximum probe temperature (Parameter)	135
Measured level (Parameter)	114
Measured lower density (Parameter)	117
Measured materials	10
Measured middle density (Parameter)	117
Measured upper density (Parameter)	117
Menu	
Diagnostics	236
Operation	112
Setup	121
Minimum level (Parameter)	206, 211
Minimum pressure (Parameter)	206, 211
Minimum probe temperature (Parameter)	135
Minute (Parameter)	233
Month (Parameter)	232

N

NMT element values (Submenu)	115
No. of preambles (Parameter)	162
Number format (Parameter)	225

Number of devices (Parameter) 125

O

Observed density (Parameter) 116, 179
 Observed density source (Parameter) 179
 Operating elements
 Diagnostics message 87
 Operating mode (Parameter) 127, 132, 138, 148
 Operating time (Parameter) 237
 Operating time from restart (Parameter) 237
 Operation (Menu) 112
 Operation mode (Parameter) 172
 Operational safety 11
 Order code (Parameter) 241
 Output density (Parameter) 129
 Output level (Parameter) 130
 Output pressure (Parameter) 128
 Output simulation (Parameter) 150
 Output temperature (Parameter) 129
 Output value (Parameter) 143, 151
 Output values (Parameter) 151
 Output vapor temperature (Parameter) 130

P

P1 (bottom) (Parameter) 118, 181
 P1 (bottom) manual pressure (Parameter) 181
 P1 (bottom) source (Parameter) 181
 P1 absolute / gauge (Parameter) 182
 P1 offset (Parameter) 182
 P1 position (Parameter) 182
 P1-2 distance (Parameter) 184
 P2 (middle) (Parameter) 118, 183
 P2 (middle) manual pressure (Parameter) 183
 P2 (middle) source (Parameter) 183
 P2 absolute / gauge (Parameter) 184
 P2 offset (Parameter) 184
 P3 (top) (Parameter) 118, 185
 P3 (top) manual pressure (Parameter) 185
 P3 (top) source (Parameter) 185
 P3 absolute / gauge (Parameter) 186
 P3 offset (Parameter) 186
 P3 position (Parameter) 186
 Parity (Parameter) 154
 Percent of range (Parameter) 165
 Polling address (Parameter) 126
 Pressure (Submenu) 118, 181
 Pressure unit (Parameter) 229
 Previous diagnostics (Parameter) 236
 Primary variable (PV) (Parameter) 165
 Probe position (Parameter) 136
 Process value (Parameter) 133, 145
 Process variable (Parameter) 134, 144
 Product safety 11
 PV mA selector (Parameter) 164
 PV source (Parameter) 162

Q

Quaternary variable (QV) (Parameter) 169

R

Readback value (Parameter) 151
 Recalibration 99
 Remedial measures
 Calling up 88
 Closing 88
 Repair concept 100
 Replacing a device 100
 Requirements for personnel 10
 Return 101
 RTD connection type (Parameter) 133
 RTD type (Parameter) 132

S

Safety distance (Parameter) 207, 212
 Safety instructions
 Basic 10
 Secondary variable (SV) (Parameter) 166
 Separator (Parameter) 224
 Serial number (Parameter) 240
 Set date (Parameter) 231
 Setup (Menu) 121
 SIL confirmation (Wizard) 234
 Simulation (Submenu) 243
 Simulation value (Parameter) 244
 Starting level (Parameter) 190
 Status signals 86, 89
 Stilling well (Parameter) 196
 Submenu
 Administration 235
 Advanced setup 124
 Alarm 214
 Analog I/O 138
 Analog IP 132
 Application 172
 Communication 153
 Configuration 154, 157, 162
 CTSh 195
 Date / time 231
 Density 116, 179
 Device information 240
 Diagnostic list 239
 Digital Xx-x 148
 Display 222
 Element position 115
 Element temperature 115
 GP values 119
 HART Device(s) 126
 HART devices 125
 HART output 162
 HTG 205
 HTMS 210
 HyTD 190
 Information 170
 Input/output 125
 Level 112, 172
 NMT element values 115
 Pressure 118, 181
 Simulation 243

System units	228
Tank calculation	188
Tank configuration	172
Temperature	114, 175
V1 input selector	160
System components	103
System polling address (Parameter)	162
System units (Submenu)	228

T

Tank calculation (Submenu)	188
Tank configuration (Submenu)	172
Tank level (Parameter)	112, 122, 173, 205
Tank Level % (Parameter)	112
Tank reference height (Parameter)	122, 173
Tank ullage (Parameter)	112
Tank ullage % (Parameter)	113
Temperature (Submenu)	114, 175
Temperature unit (Parameter)	229
Tertiary variable (TV) (Parameter)	167
Timestamp (Parameter)	236, 237, 239
Trouble shooting	85

U

Units preset (Parameter)	121, 228
Upper interface level (Parameter)	113
Used for SIL/WHG (Parameter)	146, 152

V

V1 address (Parameter)	157, 158
V1 input selector (Submenu)	160
Value 1 display (Parameter)	223
Value percent selector (Parameter)	161
Vapor density (Parameter)	116, 180
Vapor temp source (Parameter)	177
Vapor temperature (Parameter)	114, 178

W

Water density (Parameter)	212
Water level (Parameter)	113, 174
Water level source (Parameter)	173
Weight and measures configuration CRC (Parameter)	
.	241
Wire expansion coefficient (Parameter)	197
Wizard	
Deactivate SIL/WHG	234
Forget device	131
SIL confirmation	234
Workplace safety	10
Write protection	
Via write protection switch	48
Write protection switch	48

Y

Year (Parameter)	231
----------------------------	-----



71410291

www.addresses.endress.com
