

Operating Instructions

Prothermo NMT539

Average temperature device
Device functions

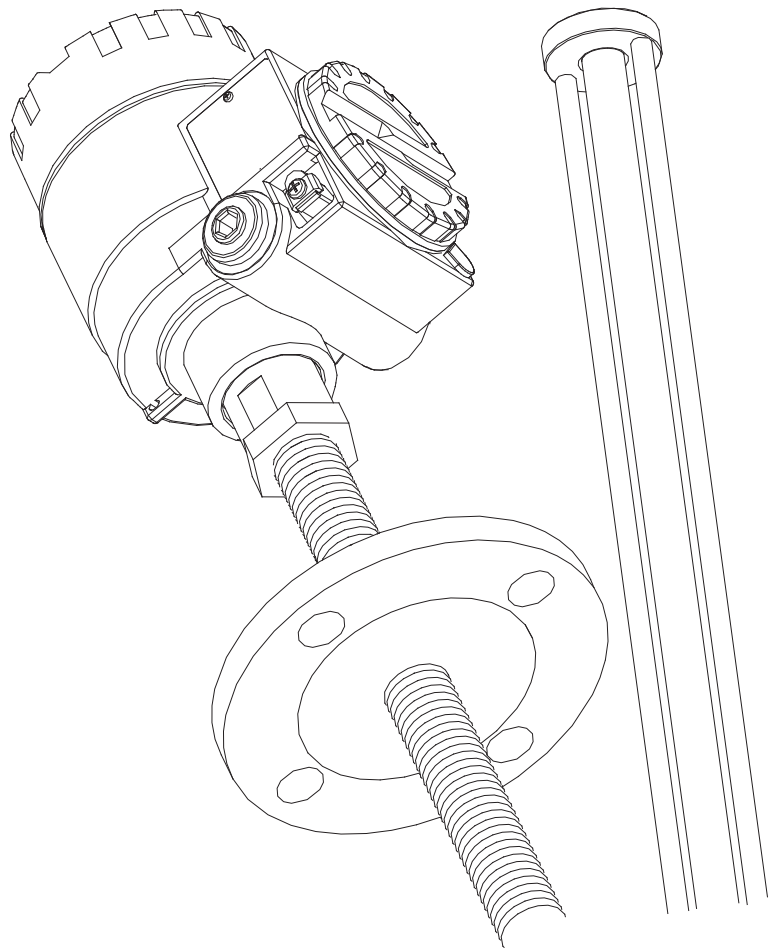

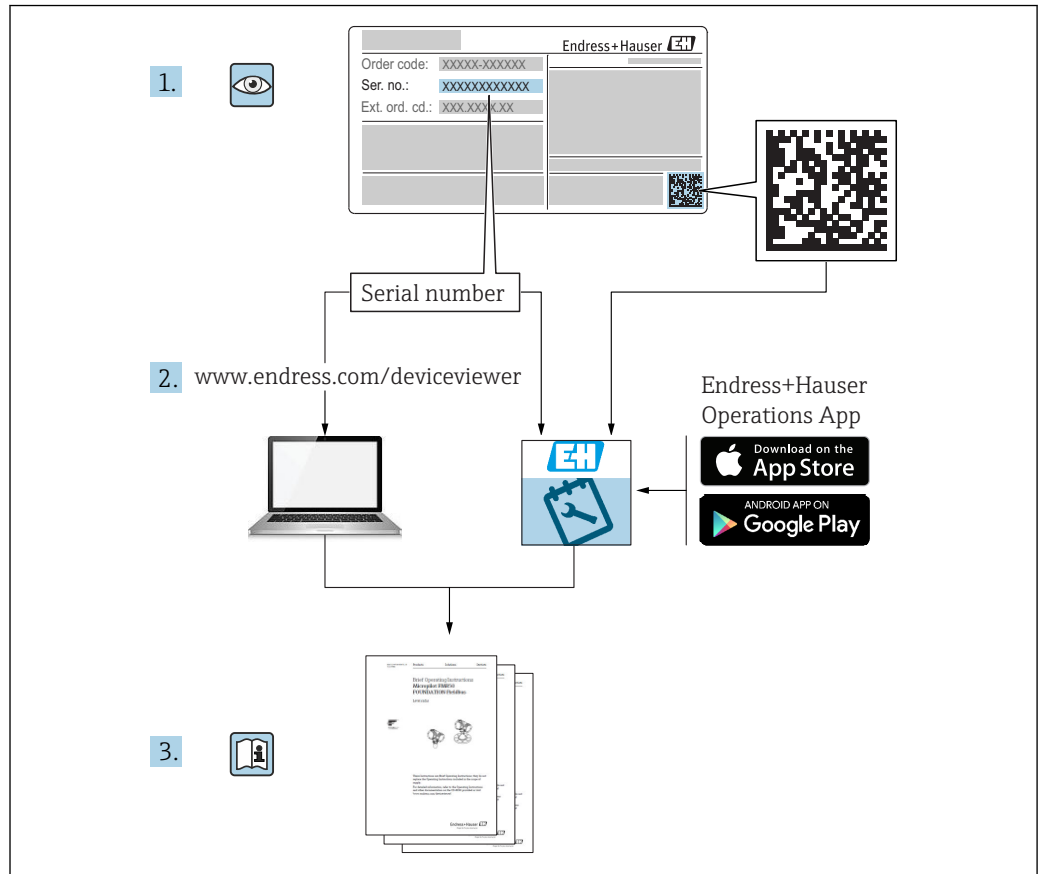

A0023555

Table of contents

1	About this document	4
1.1	Document function	4
1.2	Symbol	4
1.3	Documentation	7
1.4	Registered trademarks	7
2	Basic safety instructions	8
2.1	Requirements for personnel	8
2.2	Designated use	8
2.3	Workplace safety	8
2.4	Operational safety	9
2.5	Product safety	9
3	Product description	10
3.1	Product design	10
3.2	Technical data	10
3.3	Description of functions	13
4	Adjustment and settings	18
4.1	Local HART connection	18
4.2	Device configuration: NRF590	19
4.3	Device configuration: NMS5/NMS7	19
4.4	Configuring NMT539 with NMS8x/NMR8x/ NRF81	21
5	Operation	28
5.1	HART device codes	28
5.2	Device data	28
5.3	Temperature measurement	28
5.4	WB measurement	42
5.5	Temperature + water bottom measurement ..	47
5.6	Exclusion of WB temperature elements from average temperature calculation	47
5.7	WB (water bottom) level input from host ...	48
5.8	Temperature element near the tank bottom ..	49
5.9	Write-protection switch (write-protection plug)	51
5.10	Module configuration	51
Index		52





1 About this document

1.1 Document function







These Operating Instructions contain all the information that is required during various phases of the life cycle of the device: from product identification, incoming acceptance and storage, to mounting, connection, operation and commissioning through to troubleshooting, maintenance and disposal.

1.2 Symbol





1.2.1 Safety symbols

Symbol	Meaning
	DANGER! This symbol alerts you to a dangerous situation. Failure to avoid this situation will result in serious or fatal injury, as well as a risk of fire or explosion.
	WARNING! This symbol alerts you to a dangerous situation. Failure to avoid this situation will result in a risk of serious or fatal injury, fire or explosion.
	Note This symbol alerts you to a dangerous situation. Failure to avoid this situation will result in a risk of minor or moderate injury and damages to properties.
	NOTE! This symbol contains information on procedures and other facts that do not result in personal injury.

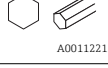

1.2.2 Electrical symbols

Symbol	Meaning
	Direct current
	Alternating current
	Direct current and alternating current
	Ground connection A grounded terminal that, as far as the operator is concerned, is grounded via a grounding system.
	Protective ground connection A terminal that must be connected to the ground prior to establishing any other connections.
	Equipotential connection This connects with the grounding system at the plant. It includes equipotential line and single point ground systems, depending on the norms of each country or company.



1.2.3 Tool symbols

Symbol	Meaning
 A0013442	Torx screwdriver
 A0011220	Flat blade screwdriver
 A0011219	Phillips screwdriver
 A0011221	Allen key
 A0011222	Open-ended wrench



1.2.4 Symbols for certain types of information

Symbol	Meaning
	Permitted Procedures, processes or actions that are permitted
	Preferred Procedures, processes or actions that are preferred
	Forbidden Procedures, processes or actions that are forbidden
	Tip Indicates additional information
	Reference to documentation
	Reference to page
	Reference to graphic
	Notice or individual step to be observed
	Series of steps
	Result of an operation or commissioning
	Help in the event of a problem
	Visual inspection
	Operation via the local display
	Operation via operating tool
	Write-protected parameter

1.2.5 Symbols in graphics

Symbol	Meaning
1, 2, 3 ...	Item numbers
1, 2, 3 ...	Series of steps
A, B, C, ...	Graphics
A-A, B-B, C-C, ...	Cross-sections
	Hazardous area Indicates the hazardous area
	Safe area (non-hazardous area) Indicates the non-hazardous area

1.2.6 Device symbol

Symbol	Meaning
	Safety instructions Observe the safety instructions contained in the associated Operating Instructions.
	Temperature resistance of the connection cables Specifies the minimum value of the temperature resistance of the connection cables.

1.3 Documentation

 For an overview of the scope of the relevant Technical Documentation included with the product, refer to the following:

- The *W@M Device Viewer*: Enter the serial number from the nameplate (www.endress.com/deviceviewer).
- The *Endress+Hauser Operations App*: Enter the serial number from the nameplate or scan the 2-D matrix code (QR code) on the nameplate.

1.3.1 Technical information

The Technical Information contains all the technical data on the device and provides an overview of the accessories and other products that can be ordered for the device.

Device	Technical Information
Prothermo NMT539	TI01005G

1.3.2 Operating instructions (BA)

The Operating Instructions contain all the information that is required during various phases of the life cycle of the device: from product identification, incoming acceptance and storage, to mounting, connection, operation and commissioning through to troubleshooting, maintenance and disposal.

The Operating Instructions also contain detailed descriptions of each parameter in the operation menu. The description is aimed at those who work with the device over the entire life cycle and perform specific configurations.

Device	Operating Instructions
Prothermo NMT539	BA01025G BA01026G

1.3.3 Safety instructions (XA)

Feature 010 ("Approval")	Meaning	Ex / XA
A	Ex ia IIB T4	Ex463-820XJ Ex1060-953XJ Ex496-826XJ
B	ATEX Ex ia IIB T2-T6	XA00585G
C	Ex ia IIB T2	Ex495-823XJ
E	Ex d[ia] IIB T4	Ex1061-986XJ
F	IEC Ex ia IIB T2-T6	XA01790G
G	NEPSI Ex ia IIB T2-T6	XA01259G
7	FM C/US IS Ci. I Div.1 Gr. C-D	Ex461-851-1 Ex461-850-1

1.4 Registered trademarks

FieldCare®

Registered trademark of the Endress+Hauser Process Solutions AG, Reinach, Switzerland.

HART®

Registered trademark of the FieldComm Group, Austin, USA.

2 Basic safety instructions

2.1 Requirements for personnel

The personnel for installation, commissioning, diagnostics and maintenance must fulfill the following requirements:

- ▶ Be specialists who are trained and have a relevant qualification for this specific function and task.
- ▶ Be authorized by the plant owner-operator.
- ▶ Be familiar with local/national regulations.
- ▶ Before starting work, read and understand the instructions in the Operating Instructions and supplementary documentation as well as the certificates (depending on the application).
- ▶ Follow instructions and comply with basic conditions.

The operating personnel must fulfill the following requirements:

- ▶ Be instructed and authorized according to the requirements of the task by the facility's owner-operator.
- ▶ Follow the instructions in this manual.

2.2 Designated use

Application and measured materials

Depending on the version ordered, the device can also be used with potentially explosive, flammable, poisonous or oxidizing materials.

Devices that are used in hazardous areas have corresponding labels on their nameplates.

To ensure that the device remains in proper condition for the operation time:

- ▶ Only use the device in full compliance with the data on the nameplate and the general conditions listed in the Operating Instructions and supplementary documentation.
- ▶ Check the nameplate to verify if the device can be put to its intended use in hazardous areas.
- ▶ If the device is not operated at an atmospheric temperature, compliance with the relevant basic conditions specified in the relevant device documentation is absolutely essential.
- ▶ Protect the device permanently against corrosion from environmental influences.
- ▶ Observe the limit values in the "Technical Information".

The manufacturer is not liable for damage caused by improper or non-designated use.

2.3 Workplace safety

For work on and with the device:

- ▶ Wear the required personal protective equipment according to local/national regulations.

2.4 Operational safety

Risk of injury!

- ▶ Operate the device in proper technical conditions and fail-safe conditions only.
- ▶ The plant owner-operator is responsible for interference-free operation of the device.

Modifications to the device

Unauthorized modifications to the device are not permitted and can lead to unforeseeable dangers:

- ▶ If modifications are nevertheless required, contact your Endress+Hauser Sales Center.

Repair

To ensure continued operational safety and reliability:

- ▶ Carry out repairs on the device only if they are expressly permitted.
- ▶ Observe local/national regulations pertaining to repair of an electrical device.
- ▶ Use only original spare parts and accessories from Endress+Hauser.

Ex-area

Observe the following notes to eliminate the risk of danger to persons or the facility when the device is used in Ex-areas (e.g. explosion protection, pressure equipment safety):

- ▶ Check the model nameplate to ensure that the ordered device is explosion proof.
- ▶ Observe the specifications in the separate supplementary documentation attached to these Instructions.

2.5 Product safety

This device was designed in accordance with GEP (Good Engineering Practice) to meet state-of-the-art safety requirements, has been tested and left the factory in a condition in which it is safe to operate. It meets the general safety standards and legal requirements.

3 Product description



3.1 Product design

NMT539 performs precise liquid and gas phase average temperature measurement, which makes it ideal for inventory management of large-scale tanks.

It is equipped with a capacitance WB device in crude oil and two-phase liquids, and it performs accurate average temperature and WB measurements.

 The position of the flange cannot be adjusted in a welding flange type.

3.2 Technical data

Item	Details
Application	<ul style="list-style-type: none"> ▪ Flange installation: Standard 50.8 mm (2 in) ▪ Temperature measuring range: Maximum length 99.999 m (3.94 in) (ATEX, IECEx, NEPSI, FM C/US), maximum length 40.000 m (1.57 in) (TIIS) ▪ WB measuring range: 1 m (3.28 ft) or 2 m (6.56 ft)
Measuring principle	<ul style="list-style-type: none"> ▪ Temperature measurement NMT539 consists of up to 16 platinum resistance elements (Pt100) in a SUS316 protection tube. Pt100 has a unique characteristic of linear resistance change with respect to the surrounding ambient temperature change. A module in the NMT539 converter receives this resistance signal change as an input variable and converts it to temperature data. The converted and calculated data are then transmitted to the host device as a local HART signal. ▪ Water bottom (water interface level) measurement An attached capacitance level measurement probe detects the presence of water. The WB is converted into a given frequency variable (default setting) and its data is transmitted via local HART converter to the connected host device.
Minimum element interval (distance)	<ul style="list-style-type: none"> ▪ Standard specifications: 150 mm (5.9 in) (Order Code: 030 Option 1, 4, 5) ▪ High temperature / Low temperature: 400 mm (15.75 in) (Order Code: 030 Option 2, 3, 6) <p> If NMT539 comes with a WB (water bottom) probe option, the maximum number of WB internal elements is two, because of the restriction posed by the internal diameter.</p>
Device structure	<p>RTD average temperature signal for local HART conversion RTD average temperature measurement + local HART converter Average temperature + WB measurement + local HART converter</p>
Measuring range	<ul style="list-style-type: none"> ▪ Temperature measurement <ul style="list-style-type: none"> ▪ Temperature conversion: -200 to 235 °C (-328 to 455 °F) (-170 to 235 °C (-274 to 455 °F) TIIS) ▪ Standard: -40 to 100 °C (-40 to 212 °F) (-20 to 100 °C (-4 to 212 °F) TIIS) ▪ Wide range: -55 to 235 °C (-67 to 435 °F) (-20 to 235 °C (-4 to 455 °F) TIIS) ▪ Cryogenic: -170 to 60 °C (-274 to 140 °F) ▪ Probe length: Maximum length 99.999 m (328.08 ft) (ATEX, IECEx, NEPSI, INMETRO, FM C/US) Maximum length 40.000 m (131.23 ft) (TIIS) ▪ WB measurement Standard probe range: 1 m (3.28 ft) or 2 m (6.56 ft) <p> -200 to 100 °C (-328 to 212 °F), which is below cryogenic temperature, can be accommodated upon request.</p>
Output signal	Local HART protocol, exclusively for the local host device
Alarm signal	<p>Error information can be accessed via the following interfaces and transmitted digital protocol (refer to "Prothermo NMT539 Operating Instructions and Description of Instrument Function" for the following instruments):</p> <ul style="list-style-type: none"> ▪ NRF590 (BA00256F, BA00257F) ▪ NMS5 (BA00401G) ▪ NMS8x (BA1456G, BA1459G, BA1462G) ▪ NMR8x (BA01450G, BA01453G) ▪ NRF81 (BA01465G)
Local HART load	Minimum loading for local HART circuit: 250 Ω
Cable glands	Thread G1/2, Thread NPT1/2, Thread M20
Supply voltage	<ul style="list-style-type: none"> ▪ DC 16 to 30 V: Ex ia ▪ DC 20 to 24 V: Ex d [ia]

Item	Details		
Power consumption	Ex ia: 6 mA (temperature measurement), 12 mA (WB measurement), Ex d [ia]: 8 mA (temperature measurement), 14 mA (WB measurement)		
Reference operating conditions	<ul style="list-style-type: none"> ■ Temperature: 25 °C (77 °F) ± 5 °C (9 °F) ■ Pressure: 1013 mbar abs. ± 20 mbar abs. (1013 hPa abs. ± 20 hPa abs., 14.7 psi abs. ± 0.3 psi abs.) ■ Relative humidity (air): 65 % ± 20 % (linearity) ■ Converter and precision resistor combination or converter and probe combination <ul style="list-style-type: none"> ■ WB measurement range: 80 % (100 to 900 mm (3.94 to 35.43 in)) ■ The factory default is adjusted based on DC (er) = 2.1. Adjustment should be made on-site when necessary 		
Measured value resolution	<ul style="list-style-type: none"> ■ Temperature: ≤ 0.1 °C (0.18 °F) ■ WB: ≤ 0.1 mm (0.004 in) 		
Maximum measurement error	The values below represent performances under the reference conditions (including linearity, repeatability, hysteresis). Conversion accuracy		
	Temperature	Standard /PTB spec.	± 0.1 °C (0.18 °F)
	WB	1 m (3.28 ft) spec.	± 2 mm (0.08 in)
		2 m (6.56 ft) spec.	± 4 mm (0.16 in)
	Probe system		
	Temperature	Standard spec.	± 0.15 °C + 0.002 °C x t (0.27 °F + 0.0036 °F t) IEC 60751 / DIN EN 60751 / JIS C1604 Class A temperature element
		PTB spec.	± (0.3 °C + 0.005 °C x t) / 10 ((0.54 °F + 0.009 °F x t) / 10) Class 1/10B temperature element
	WB	1 m (3.28 ft) spec.	± 2 mm (0.08 in)
		2 m (6.56 ft) spec.	± 5 mm (0.2 in)
	Overall accuracy		
	Temperature	Standard spec.	Conversion accuracy ± 0.1 °C (0.18 °F) + Environmental effect ± 0.05 °C (0.09 °F) + Class A temperature element ± 0.15 °C + 0.002 °C x t (0.27 °F + 0.0036 °F x t)
		PTB spec.	Conversion accuracy ± 0.1 °C (0.18 °F) + Environmental effect ± 0.05 °C (0.09 °F) + Class 1/10B temperature element ± (0.3 °C + 0.005 °C x t) / 10 (0.54 °F + 0.009 °F x t / 10)
	WB	1 m (3.28 ft) spec.	Conversion accuracy ± 2 mm (0.08 in) + Probe accuracy ± 2 mm (0.08 in)
		2 m (6.56 ft) spec.	Conversion accuracy ± 5 mm (0.2 in) + Probe accuracy ± 5 mm (0.2 in)
 Accuracy can be improved for each application by making adjustments on-site, such as adjusting the offset. <ul style="list-style-type: none"> ■ t represents the temperature of the measured item. 			
Ambient temperature	<ul style="list-style-type: none"> ■ -40 to 85 (-40 to 185) ■ -20 to 60 °C (-4 to 140 °F): TUIS 		
Storage temperature	-40 to 85 (-40 to 185)		
Climate class	DIN EN 60068-2-38 (test Z/AD)		
Protection class	<ul style="list-style-type: none"> ■ IP66/68 NEMA4X/6P: Converter set equipped with a temperature device or a WB device ■ IP65 NEMA4X: Converter only (open housing: IP20) 		
Electromagnetic compatibility	When installing the probes to metal or concrete tanks and when using a coax probe: <ul style="list-style-type: none"> ■ Interference emission according to EN 61326, Electrical Equipment Class B ■ Interference immunity according to EN 61326, Annex A (Industrial) 		
Process temperature range	Temperature probe: -175 to 235 °C (-274 to 455 °F) WB probe: -0 to 100 °C (32 to 212 °F)		
Process pressure	Atmospheric pressure (absolute pressure 1 bar, 100 kPa, 14.5 psi) <ul style="list-style-type: none">  Pressure tank: If the pressure inside the tank exceeds the process pressure shown above, install a stilling well (protective tube) without holes or slits in the NMT539 to protect the probe from the pressure. <ul style="list-style-type: none"> ■ Static pressure: Because NMT539 has undergone an airtightness test at an absolute pressure of 7 bar, it can withstand static pressure head in the 50 m (164 ft) range in petroleum/chemical product applications. 		
Data transmission	<ul style="list-style-type: none"> ■ Minimum cable diameter: #24 AWG ■ Cable type: Twist pair with a shield 		

Item	Details
Weight	Approx. 13 kg Conditions <ul style="list-style-type: none"> ▪ Number of elements: 16 points ▪ Temperature probe: 10 m (32.8 ft) ▪ WB probe: 1 m (3.28 ft) ▪ Flange: 2" 150 lbs RF, SUS316
Material	<ul style="list-style-type: none"> ▪ Temperature measurement elements: Class A Pt100, IEC60751/DIN EN60751/JISC1604 ▪ Housing: Aluminum die cast ▪ Temperature probe: SUS316, SUS316L (refer to the "Dimension") ▪ WB probe: SUS316 (center rod SUS 304 / PFA protected)
Flange specifications	<ul style="list-style-type: none"> ▪ 10K 50A RF, SUS316, flange JIS B2220 ▪ NPS 2" Cl.150 RF, SUS316 flange ASME B16.5 ▪ DN50 PN10 B1, SUS316, flange EN1092-1 (DIN2527 B) ▪ 50A 150 lbs RF, SUS316, flange JPI 7S-15 ▪ Universal coupling, G3/4, (converter only) ▪ M20 threaded (converter only)
CE approval	By attaching the CE mark, Endress+Hauser confirms that the instruments have passed the required tests.
External standards and guidelines	<ul style="list-style-type: none"> ▪ EN 60529 ▪ Protection class of housing (IP-code) ▪ EN 61326 ▪ Emissions (equipment class B), compatibility (appendix A – industrial area)
Ex approvals	<p>ATEX</p> <ul style="list-style-type: none"> ▪ II 1/2 G Ex ia IIB T2-T6 Ga/Gb (converter with temperature device and/or WB device) ▪ II 2G Ex ia IIB T2-T6 Gb (converter only) <p>IEC</p> <ul style="list-style-type: none"> ▪ Ex ia IIB T2-T6 Ga/Gb (converter with temperature device and/or WB device) ▪ Ex ia IIB T2-T6 Ga (converter only) <p>FM C/US Converter with temperature device and/or WB device</p> <ul style="list-style-type: none"> ▪ IS Cl. I, Div. 1, Gr. C, D T2-T6 ▪ IS Cl. I, Zone 0, AEx ia IIB Ga T2-T6 ▪ NI Cl. I, Div. 2, Gr. C, D T2-T6 <p>Converter only</p> <ul style="list-style-type: none"> ▪ IS Cl. I, Div. 1, Gr. C, D T4 ▪ IS Cl. I, Zone 0, AEx ia IIB Ga T4 ▪ NI Cl. I, Div. 2, Gr. C, D T4 <p>TIIS</p> <ul style="list-style-type: none"> ▪ Ex ia IIB T4 (converter with temperature device and/or WB device) (converter only) ▪ Ex ia IIB T2 (converter with temperature device) ▪ Ex d[ia] IIB T4 (converter with temperature device and/or WB device) <p>NEPSI</p> <ul style="list-style-type: none"> ▪ Ex ia IIB T2-T6 (converter with temperature device and/or WB device) ▪ Ex ia IIB T2-T6 Ga (converter only)

3.3 Description of functions

Detailed descriptions of the function groups, functions and parameters are given in "NMT539 Operating Instructions and Description of Instrument Functions." When NMT539 with WB probe and NRF590 are used together, confirm that the supply voltage to TMD1/NMS/TGM/NRF590 is stable at a voltage of 100 VAC or higher.

3.3.1 NMT539 Ex ia and NMS8x Exd [ia] combination

The connection of NMT539 shown below is only available for connection with NMS5 or NMS8x.

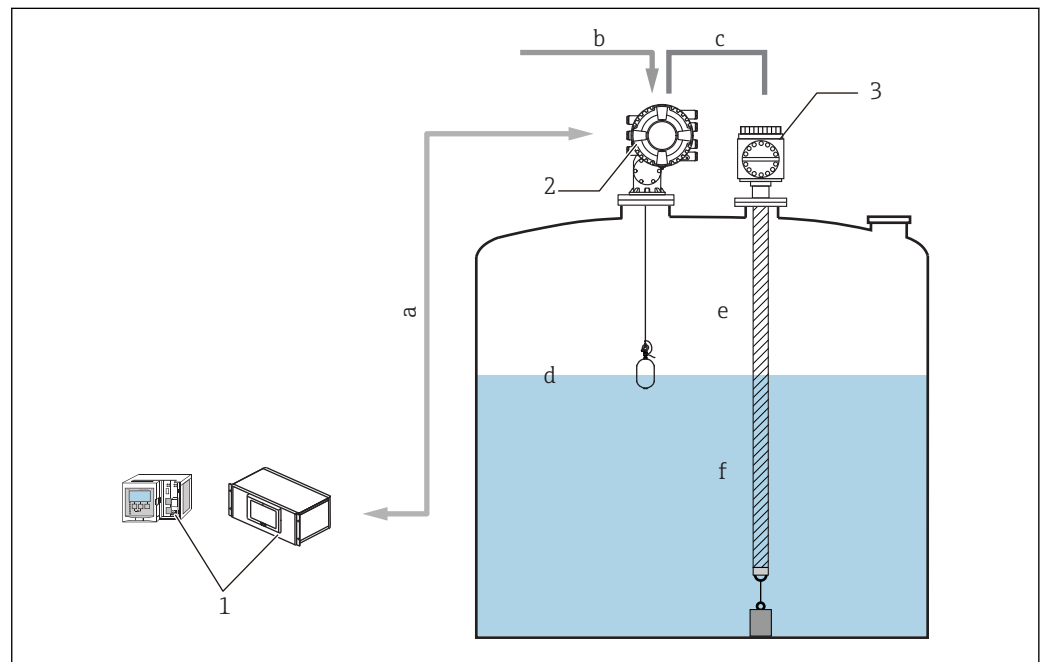

1 NMS8x and NMS539 system design

- a Fieldbus protocol
- b Power supply
- c Local HART (Ex i) loop (data transmission)
- d Level
- e Gas temperature
- f Liquid temperature
- 1 Tankvision
- 2 NMS8x
- 3 NMT539

Typical application of NMT539 converter + temperature probe version

NMT539 is the successor of the former NMT535. For proper migration, NMT539 has inherited all the functionality and specifications of NMT535, including connection flange specifications, cable entries and wiring method. Since NMS5 or NMS8x is provided with WB measurement function, they can be combined with the converter + average temperature probe version of NMT539. When the converter + average temperature probe + WB probe version is combined with NMS5 or NMS8, the product in the tank will simultaneously be managed with level, continuous temperature and WB measurements. Most changes and parameter settings for NMT539 can be performed by NMS5 or NMS8x. NMT539 receives liquid level data from NMS5 or NMS8x and then calculates the average temperature of the liquid and gas phases. The calculated average temperature data of the

liquid and gas phases are transmitted to NMS8x or NMS5 along with the measured temperature of each element and the NMT539 device status.

i All gathered data in the field interface unit are sent to inventory management software (Tankvision) or to NMS8x, NMS5x, NMS7, NMR8x, NRF8x or NRF590.

3.3.2 NMT539 Ex ia and NMR8x Ex d [ia] combination

The connection of NMT539 shown below is only available for connection with NMR8x Ex d [ia].

NRF81 is required as a gateway for FMR5xx and NMT539 Tankvision when using FMR5xx Ex ia radar.

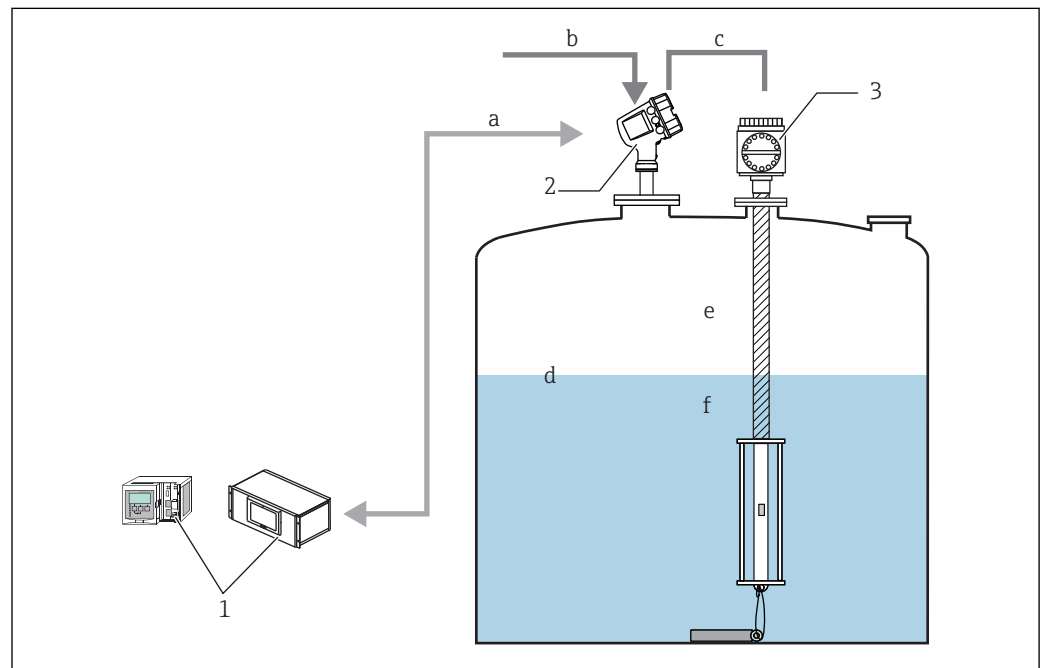

2 NMT539 Ex ia and NMR8x combination

- a Fieldbus protocol
- b Power supply
- c Local HART (Ex i) loop (data transmission)
- d Level
- e Gas temperature
- f Liquid temperature
- 1 Tankvision
- 2 NMR8x
- 3 NMT539

3.3.3 NMT539 Ex ia and NRF590 Ex d [ia] combination

Typical application of NMT539 converter + temperature probe + WB probe version

The NMT539 converter + temperature probe + WB probe version is utilized most effectively in combination with radar level gauging. Water interface, temperature and liquid level measurement, with data collection and calculations via the NRF590 or NRF81, allow for optimal inventory control. Details on NMT539 functions and data can be accessed from NRF81 or NRF590. NMT539 receives radar level data from NRF590 or NRF81 and then calculates the average temperature of the liquid and gas phases. The calculated average temperature data of the liquid and gas phases are transmitted to NRF81 or NRF590 along with the measured temperature of each element and the NMT539 device status.

 All gathered data in the field interface unit are sent to inventory management software (Tankvision) or to NMS8x, NMS5x, NMS7, NMR8x, NRF8x or NRF590.

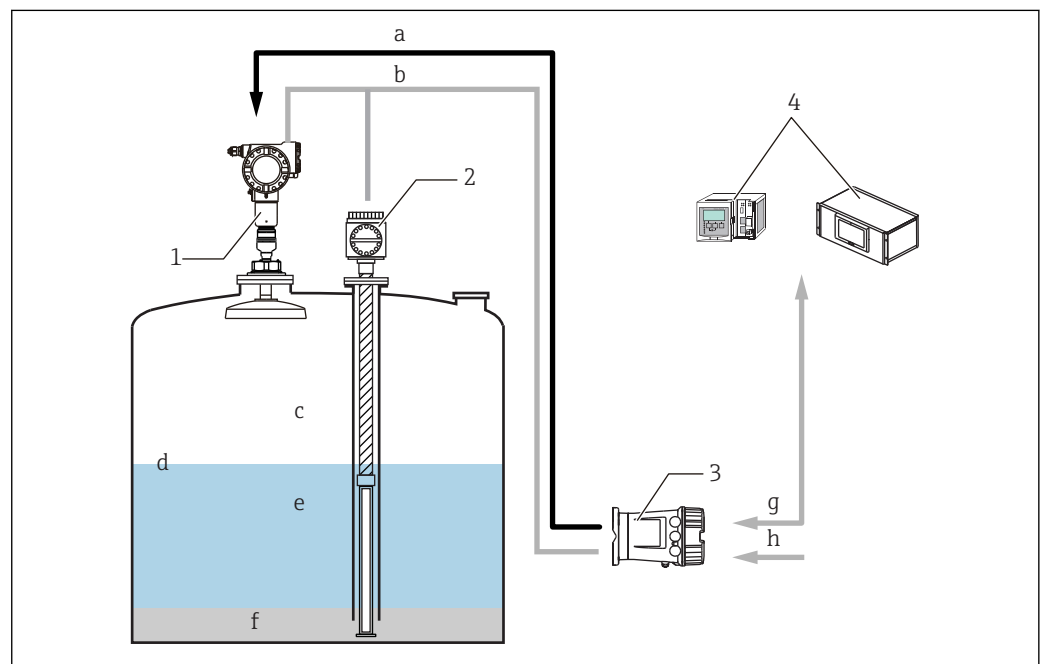

A0038541

 3 NMT539 Ex ia and NRF590 Ex d [ia] combination

- a FMR power supply (DC/Ex i)
- b Local HART (Ex i) loop (data transmission)
- c Gas temperature
- d Level
- e Liquid level temperature
- f Water
- g Fieldbus protocol
- h Power supply
- 1 FMR540
- 2 NMT539
- 3 NRF81/NRF590
- 4 Tankvision

3.3.4 NMT539 Ex d [ia] and TMD1 Ex d combination

Average temperature device NMT539 can be connected to Transmitter TMD1 or Servo Level Gauge TGM5 via local HART (Ex d) communication. Because local HART communication is digital, it is able to send a larger volume of information compared to the conventional RTD method. This means that NMT539 can work with not just DRM9700 but also with NRF560. If NMT539 WB probe and NRF560 are used together, confirm that the supply voltage to TMD1 is stable at 100 VAC or higher.

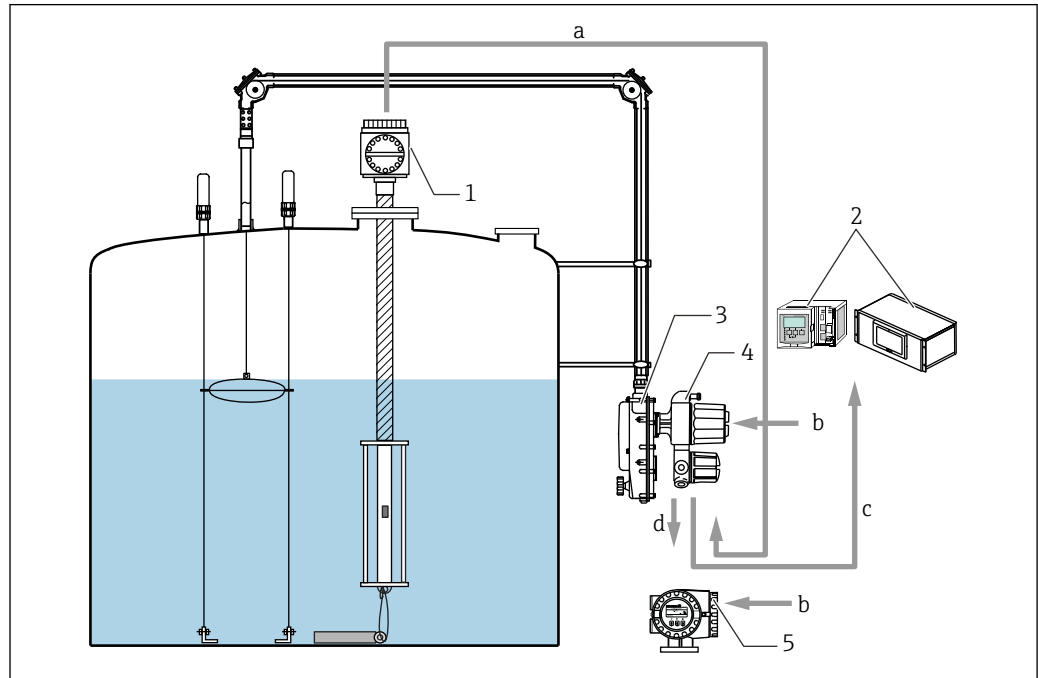

A0038542

4 NMT539 Ex d [ia] and TMD1 combination

- a Local HART (Ex d) loop (data transmission)
- b Power supply
- c Fieldbus protocol
- d HART (Ex d) loop (data transmission)
- 1 NMT539
- 2 Tankvision
- 3 LT5
- 4 TMD1
- 5 NRF560

3.3.5 NMT539 Ex d [ia] and TGM5 combination

When NMT539 with WB probe and NRF560 are used together, confirm that the supply voltage to TGM5 is stable at 100 VAC or higher.

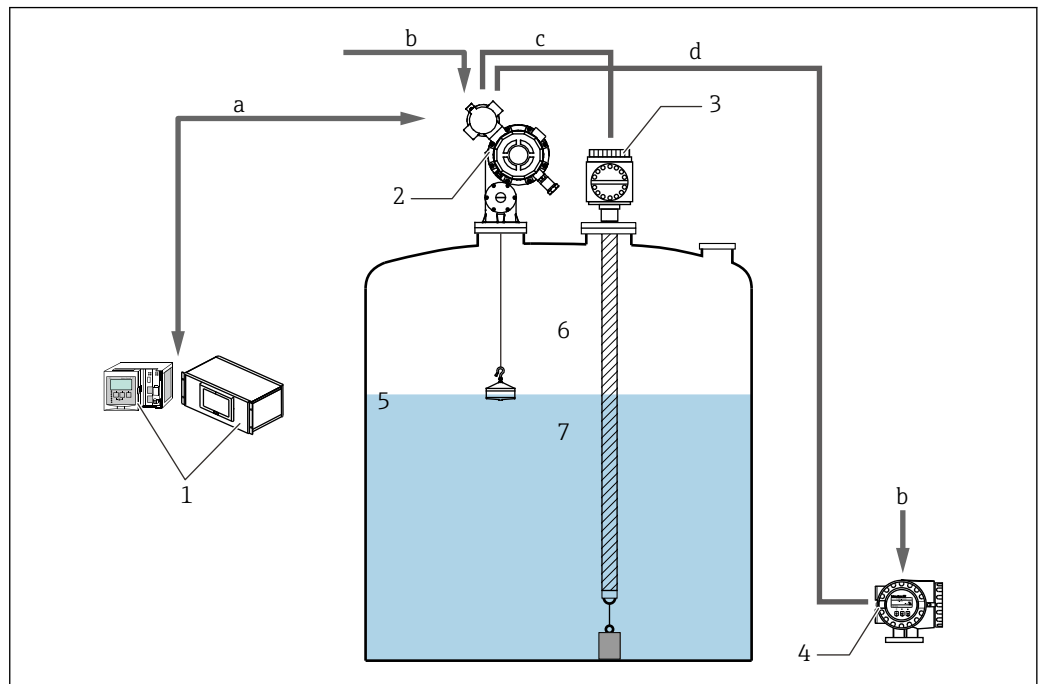

5 NMT539 Ex d [ia] and TGM5 combination

- a Fieldbus protocol
- b Power supply
- c Local HART (Ex d) loop (NMT539 and TGM5)
- d Local HART (Ex d) loop (TGM5 and NRF560)
- 1 Tankvision
- 2 TGM5
- 3 NMT539
- 4 NRF560
- 5 Level
- 6 Gas temperature
- 7 Liquid temperature

4 Adjustment and settings

4.1 Local HART connection

4.1.1 Endress+Hauser tank gauging instrument

NMT539 is designated to work with Endress+Hauser tank instruments tank side monitors NRF590, NRF81 or Proservo NMS5, NMS7, NMS8x or NMR8x to build a comprehensive instrumentation system. Both temperature and/or WB information is transmitted via HART loop. NRF590, NRF81 and NMS5, NMS, NMS8x and NMR8x have a settings menu for the NMT Series by default, which means that they can configure NMT539 default settings.

-  The parameters listed in this document are parameters that can be checked when the instruments are connected to NMT539 with FieldCare. Since the parameters that can be checked from the HMI of the connected HART Master, such as NMS8x and NMS5, differ depending on which HART Master is being used, refer to the respective operating instructions.
 - Before starting up NMT539, refer to "Prothermo NMT539 Operating Instructions" and check the installation procedure.
 - There are four types of standard basic data depending on the NMT539 measurement function.

4.1.2 Measuring functions

Temperature measurement

0	Converter only
1	Temperature + converter

These four types of basic data are available as standard.

- Average liquid temperature
- Average gas temperature
- Level (VH02 measured distance)
- Device status

Water bottom measurement

2	WB probe + converter
---	----------------------

These four types of basic data are available as standard.

- WB level
- WB probe capacitance
- WB probe frequency
- Device status

Temperature + WB + converter

3	Temperature + WB + converter
---	------------------------------

These four types of basic data are available as standard.

- Average liquid temperature
- WB level
- Average gas temperature
- Device status

4.2 Device configuration: NRF590

Connect the loop-powered local HART communication cable from NRF590 (intrinsically safe side compartment) to NMT539 according to "Prothermo NMT539 Operating Instructions." NRF590 has been designed to recognize NMT539 as a specific Endress +Hauser local HART device.

4.2.1 HART scanner

Once NMT539 and NRF590 have been wired together, all HART devices will be scanned automatically when NRF590 is turned on.

 Not all NRF590 are fully compatible for recognizing NMT539. Contact your Endress +Hauser Sales Center for information on NRF590 software and hardware version compatibility.

4.2.2 NMT539 specific parameter setup for NRF590

The configuration of NMT539 parameters displayed on NRF590 depends on the installed software and hardware versions of NRF590. Refer to the NRF590 operating manual to determine accessible parameters. All default settings and parameter configurations can be carried out using FieldCare. Detailed information will be provided in the following sections.

4.3 Device configuration: NMS5/NMS7

NMS5/NMS7 are specifically designed to recognize NMT539 as HART Master. Terminals 24 and 25 of NMT539 and NMS5/NMS7 are connected with a local HART cable.

 Connection between NMS5/NMS7 and NMT539 is required for Ex Approval. Follow the separate BA01025G operating instructions, "4.4.Terminal connection."

4.3.1 Preparation for NMS5/NMS7 configuration

NMS5/NMS7 must be set to default before connecting to NMT539.

Code	Display	Details
GVH362	NMT Connection	Select "NMT Connection" and "Average" and configure the NMT.  To change this parameter, an access code is required. For details, see "Prothermo NMT539 Operating Instructions."

4.3.2 Configuring NMT539 with NMS5/NMS7

NMT539 parameters can be configured using the NMS5/NMS7 programming matrix G4 "Temperature Device."



Typical NMT539 parameters (same as NMT535) are displayed in the NMS5/NMS7 matrix.

 WB probe information is not available on NMS5/NMS7 ROM version 4.24 or earlier versions. Contact your Endress+Hauser Sales Center to update existing NMS5/NMS7 functions.

G0 Static Matrix

Code	Display	Details
GVH010	Liquid temp	NMT539 displays the average liquid temperature.
GVH013	Gas temp	NMT539 displays the average gas temperature.

G4 Temperature Matrix

Code	Display	Details
GVH440	Liquid temp	Displays the same value indicated in GVH010: Liquid temp
GVH441	Gas temp	Displays the same value indicated in GVH013: Gas temp
GVH442	Level	The liquid level collected from NMS5/NMS7 is selected as either GVH000: Level (Displacer position) or GVH008: Level data (Level). NMT539 calculates both liquid and gas phase temperatures based on this liquid level data.
GVH447	Element No. 0 temp	Checks that the measuring temperature resistor temperature conversion is executed correctly. The tolerance range is -1.0 to 1.0 °C (-30.2 to 33.8 °F).
GVH449	Element temp 17 temp	This temperature is used for checking when shipping from the factory.
GVH450-459	Element temp No.1-10 temp	The measured temperature is the temperature data collected from each element (maximum 16 points). The temperature measurement elements 11 to 16 are selected from GVH470 "Select point," and the selected element is displayed in GVH473 "Element temp."
GVH460-469	Element No.1-10 position	Indicates the position of each element in the probe. Temperature measurement elements 11 to 16 are selected from GVH470 "Select point," and the selected element is displayed in GVH474 "Element position."
GVH470	Select point	A matrix is selected for GVH471 "Zero Adjust," GVH473 "Element temp" and GVH474 "Element position," and required element data are input.
GVH480	Diagnostic	Displays error code messages. Refer to the error code chart in this manual.
GVH482	Element number	The number of elements installed on the temperature measurement tube is entered.
GVH485	Type of interval	Sets measurement element intervals. If the element intervals are equal, select GVH487 "Element interval" to set the interval, and then select GVH486 "Bottom point" to set the height of the lowest edge of the elements. If the element intervals are not equal, manually set the intervals.  This parameter configuration is only used to change the theoretical element position within NMT539's software for average temperature calculation. The physical positions of the elements will not change.
GVH486	Bottom point	Sets the height of the lowest element. This is only set when the elements have equal intervals.  This parameter configuration is only used to change the theoretical element position within NMT539's software for average temperature calculation. The physical positions of the elements will not change.
GVH487	Element interval	The element interval is entered if "Equal interval" was selected in GVH485 "Type of interval."  This parameter configuration is only used to change the theoretical element position within NMT539's software for average temperature calculation. The physical positions of the elements will not change.

4.4 Configuring NMT539 with NMS8x/NMR8x/NRF81

NMS8x, NMR8x and NRF81 are specifically designed to recognize NMT539 as HART Master. Terminals E1 and E2 or B3 and C3 of NMR8x, NRF81 and NMS8x are connected to NMT539 with a local HART cable.

i Connection from NMS8x, NMR8x and NRF81 to NMT539 is required for Ex Approval. Follow the connection instructions in the separate BA01025G operating instructions, "Terminal connection."

4.4.1 Preparation for configuring NMS8x/NMR8x/NRF81

NMS8x, NMR8x and NRF81 must be set to default before connecting to NMT539.

Setting procedure

1. From the Expert menu, choose **Input/Output** → **HART device** → **HART device(s)** → **NMT device configuration**.
2. Select **"Yes"** for **Config. device?**
3. Enter the bottom temperature element in **Bottom point** (see diagram below).

This completes the setting procedure.

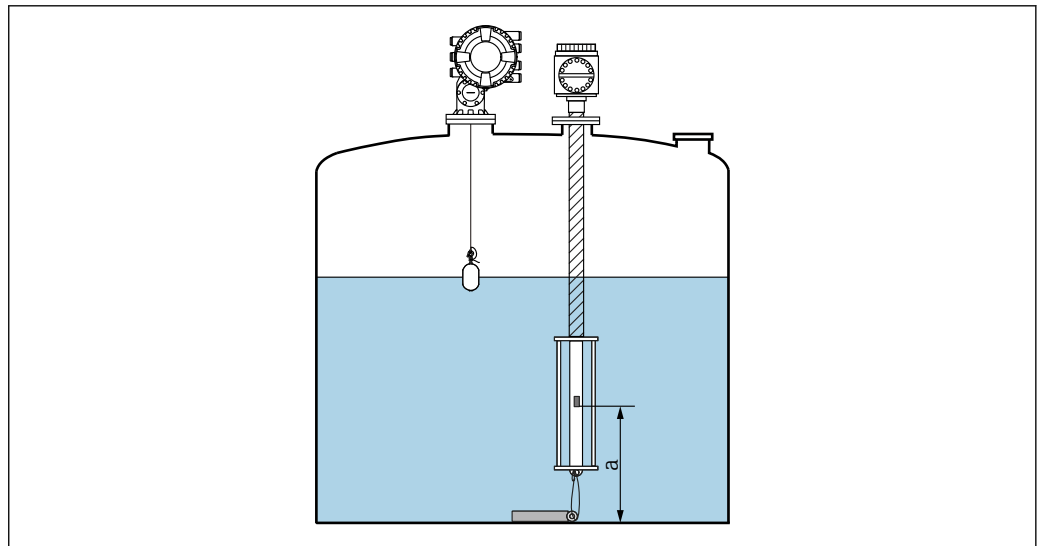

6 Position of the bottom-point temperature element

a Distance between the bottom-point temperature element to the reference (tank bottom or reference plate)

i Default *a* is 500 mm (19.69 in), but this can be modified as needed.

Liquid temperature display

Item	Details
Navigation	Operation → Temperature → Liquid temp
Description	Displays the average or spot temperature of the measured liquid.
Additional information	Read access: Operator
	Write access: -

Manual gas phase temperature display

Item	Details
Navigation	 Operation → Temperature → Manual gas phase temperature
Description	Displays the temperature of the measured gas.
Additional information	Read access: Operator
	Write access: -

Display of element temperature 1-24

Item	Details
Navigation	 Operation → Temperature → Manual gas phase temperature
Description	Displays the NMT element temperature.
Additional information	Read access: Operator
	Write access: -

Selection of liquid level

Item	Details
Navigation	 Setting → Advanced settings → Application → Tank settings → Level → Select liquid level
Description	Sets the liquid level source.
Selection	No input
	HART device, Level 1-15
	Level SR (see Note)
	Liquid level (see Note)
	Displacer position (see Note)
	AIO B1-3 value
	AIO C1-3 value
	AIP B4-8 value
AIP C4-8 value	
Factory setting	The setting is different depending on the device.
Additional information	Read access: Operator
	Write access: -



The display will be different depending on the selected options and equipment settings.

4.4.2 NMS8x/NMR8x/NRF81 configuration

Below are NMT539-related parameters. For details on the operation of NMS8x, NMR8x and NRF81, see their respective operating instructions.

The following parameters can be checked from the display accessed through the Main Menu → Expert → Input/Output → HART device → HART device(s) [MenuName].

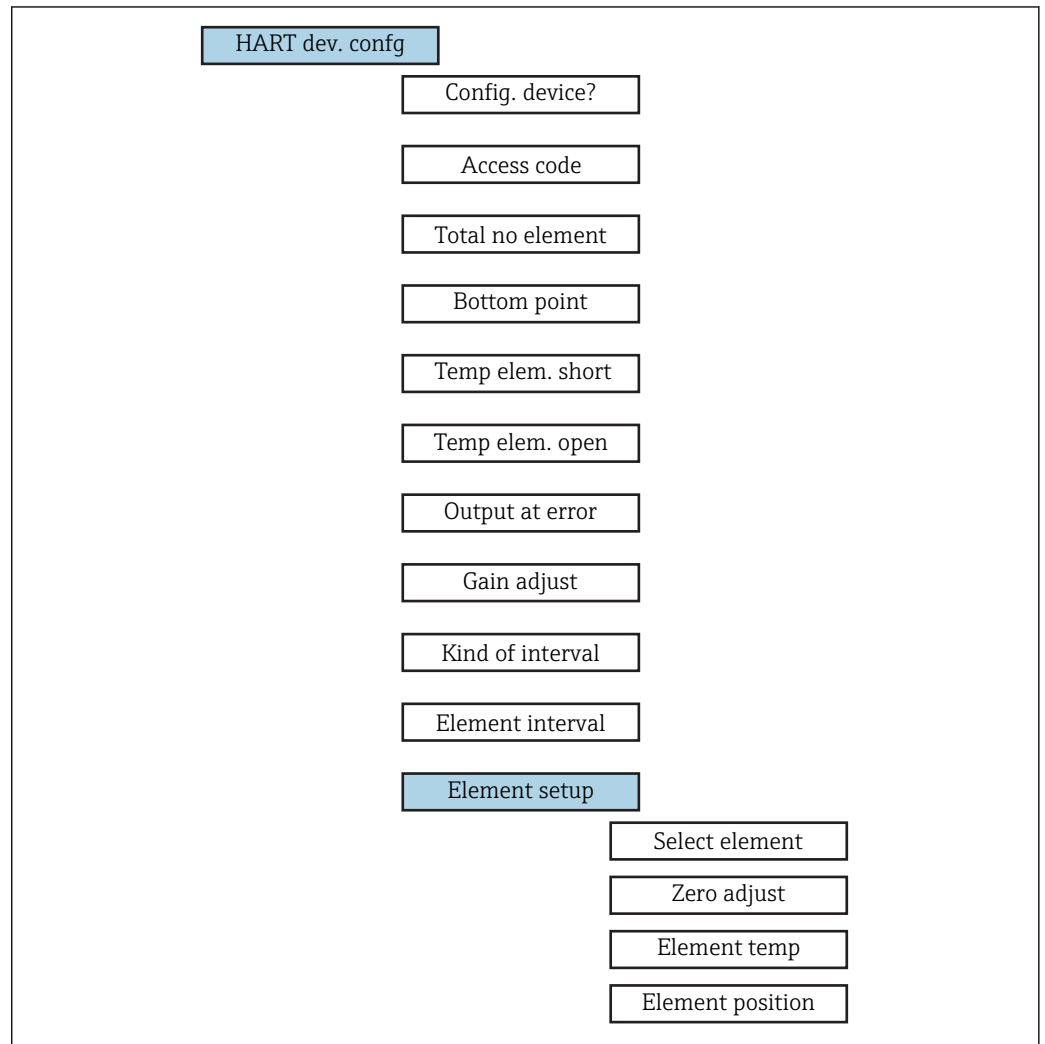



A0038545-EN

7 Parameter structure



Configure device?

Item	Details
Navigation	Expert → Input/Output → HART Device → HART device(s) [MenuName] → HART device configuration → Config. device? (14728)
Description	Configures the NMT device.
Selection	Yes (The device is recognized as NMT) No (The device will not be recognized)
Factory setting	No
Additional information	Read access: Operator Write access: Maintenance



Access code

Item	Details
Navigation	  Expert → Input/Output → HART device → HART device(s) [MenuName] → HART Device configuration → Access code (14714)
Conditions	Configure device? = Yes
Description	Displays the access code.
Input range	0-65535
Factory setting	0
Additional information	Read access: Operator
	Write access: Maintenance



Total number of elements

Item	Details
Navigation	  Expert → Input/Output → HART device → HART device(s) [MenuName] → HART Device configuration → Total No. elements (14730)
Description	Displays the total number of elements that can be configured.
Additional information	Read access: Operator
	Write access: -



Bottom point

Item	Details
Navigation	  Expert → Input/Output → HART device → HART device(s) [MenuName] → HART Device configuration → Bottom point (14729)
Description	Displays the bottom-point temperature element.
Input unit	Numerical value (mm)
Factory setting	0 mm
Additional information	Read access: Operator
	Write access: Maintenance



Temp element short

Item	Details
Navigation	  Expert → Input/Output → HART device → HART device(s) [MenuName] → HART device configuration → Temp elem.short (14731)
Description	Configures the error code for when an element short-circuits.
Input unit	Numerical value (°C)
Factory setting	0 °C
Additional information	Read access: Operator
	Write access: Maintenance



Temp element open

Item	Details
Navigation	  Expert → Input/Output → HART device → HART device(s) [MenuName] → HART device configuration → Temp elem. open (14732)
Description	Configures the error code for when an element is open.
Input unit	Numerical value (°C)
Factory setting	0 °C
Additional information	Read access: Operator
	Write access: Maintenance



Output error

Item	Details
Navigation	  Expert → Input/Output → HART device → HART device(s) [MenuName] → HART device configuration → Output error (14733)
Description	Selects the error display for when an element shorts and opens.
Selection	OFF
	ON
Additional information	Read access: Operator
	Write access: Maintenance



Gain adjust

Item	Details
Navigation	  Expert → Input/Output → HART device → HART device(s) [MenuName] → HART device configuration → Gain adjust (14736)
Description	Adjusts the temperature of all elements and references 0 and 17.
Input unit	Numerical value
Factory setting	0
Additional information	Read access: Operator
	Write access: Maintenance



Kind of interval

Item	Details
Navigation	  Expert → Input/Output → HART device → HART device(s) [MenuName] → HART Device configuration → Adjust interval (14744)
Description	Sets the type of element interval.
Selection	Equal
	Unequal
Factory setting	Equal
Additional information	<ul style="list-style-type: none"> ■ Equal division: Bottom point + Element interval ■ Unequal: Set manually
	Read access: Operator
	Write access: Maintenance



Element interval

Item	Details
Navigation	  Expert → Input/Output → HART device → HART device(s) [MenuName] → HART device configuration → Element interval (14743)
Conditions	Kind of interval: Equal
Description	Sets the interval of each element.
Input unit	Numerical value
Factory setting	0 mm
Additional information	Read access: Operator
	Write access: Maintenance



Select element

Item	Details
Navigation	  Expert → Input/Output → HART device → HART device(s) → NMT device configuration → Element configuration → Select element (14734)
Description	The element to be configured is manually selected.
Input unit	1-16
Factory setting	1
Additional information	Read access: Operator
	Write access: Maintenance

Zero adjust

Item	Details
Navigation	  Expert → Input/Output → HART device → HART device(s) → NMT device configuration → Element configuration → Zero adjust (14735)
Description	Adjusts the offset of the selected element.
Input unit	Numerical value
Factory setting	0 (None)
Additional information	Read access: Operator
	Write access: Maintenance

Element temperature

Item	Details
Navigation	  Expert → Input/Output → HART device → HART device(s) → NMT device configuration → Element configuration → Element temp (14737)
Description	Displays the element temperature.
Additional information	Read access: Operator
	Write access: -

Element position

Item	Details
Navigation	 Expert → Input/Output → HART device → HART device(s) → NMT device configuration → Element configuration → Element position (14738)
Description	Adjusts the element position.
Input unit	Numerical value
Factory setting	0 mm
Additional information	Read access: Operator
	Write access: Maintenance

5 Operation

The following configuration uses FieldCare. NMT539 has different HART device codes depending on the measurement function. The following four local HART device codes are preset at the factory based on the jumper setting.

WARNING

Modification of modules

Changing the jumper setting by disassembling the internal module of NMT539 may invalidate the accuracy of the calibration that was performed at the factory. It may also cause serious accidents.

- ▶ Do not disassemble a module or change the jumper setting.

5.1 HART device codes

Code	Details	Descriptions
184	Device code for temperature measurement function	184 is specially designed for the NMT539 converter-only version and converter + temperature probe version. Code 184 is used in an NMT539 that is not equipped with a WB probe.
185	Device code for NMT539 WB measurement function	FieldCare does not recognize Code 185.
186	Device code for fully-equipped NMT539	Code 186 is used for NMT539 that is equipped with converter + temperature probe + WB probe.

5.2 Device data

Item	Details	Descriptions
Tag number	Read / Write	This number is for customer-specified device identification and control number, tank name, site name and other ID
	Default: HART	
Assembly number	Read / Write	This number is for manufacture control based on production process.
	Default: 0	

5.3 Temperature measurement

HART device code 184 is designed for the temperature measurement function. Available parameters and functions are as follows. The description of parameters is based on the FieldCare display screen.



 The HART device code appears in the default header position or on the FieldCare display screen only when VH99 "Device Type Code" has been selected.

Devices with a temperature measurement function as specified by product order codes are as follows.

Measuring functions

Setting	Details
0	Converter only
1	Converter + temperature probe
4	Converter + temperature probe (W&M certificate)

5.3.1 Primary value: VH00-VH09

Code	Display	Details	
VH00	Liquid Temp (Average liquid temperature)	Item type	Read only
		Range	-200 to 240 °C (-328 to 464 °F)
		 Display of the average temperature of the liquid phase The measured liquid levels that are required for calculating the average temperature of the liquid phase are provided by Micropilot FMR Series (via NRF590) or NMS5, NMS7 or NMS8x.	
VH01	Gas Temp (Average gas temperature)	Item type	Read only
		Range	-200 to 240 °C (-328 to 464 °F)
		Displays the average temperature of the measured gas (vapor) phase  Gas phase measurements that are required for calculating the average gas phase temperature are provided by Micropilot FMR series (via NRF590) or NMS5, NMS7 or NMS8x.	
VH02	Measured Distance (Liquid level)	Item type	Read only
		Range	0 to 99 999 mm
		Displays the liquid level inside the tank as configured by a level gauge. If a level gauge is not connected, a directly input liquid level can be used as a device test.	
VH07	Temperature 0 (Element 0 temperature)	Item type	Read only
		Tolerance	-1.0 to 1.1 °C (30.2 to 33.8 °F)
		Checks that the measuring temperature resistor temperature conversion is executed correctly.	
VH09	Temperature 17 (Element 17 temperature)	Item type	Read only
		This temperature is used for checking when shipping from the factory.	

5.3.2 Temperature measurement elements 1: VH10-VH19

Code	Display	Details	
VH10-19	Temperature 1-10 (Temperature of elements 1 to 10)	Item type	Read only
		Range	-200 to 240 °C (-328 to 464 °F)
		Displays individual temperature measurement elements.	

5.3.3 Temperature measurement elements 2: VH20-VH29

Code	Display	Details	
VH20-25	Temperature 11-16 (Temperature of elements 11 to 16)	Item type	Read only
		Range	-200 to 240 °C (-328 to 464 °F)
		Displays individual temperature measurement elements.	
VH26	Selec. Ave Method (Average temperature calculation method)	Item type	Selection
		Selection	Standard / Advanced
		Selects the method of average temperature calculation.	

Standard calculation method

Regardless of the shape of the tank, average temperature is calculated using the following formula:

Formula: $(T1 + T2 + T3) / \text{Number of elements in liquid phase} = \text{Average temperature}$
 $(3.5\text{ °C (38.3 °F)} + 3.0\text{ °C (37.4 °F)} + 2.0\text{ °C (35.6 °F)}) / 3 = 2.83\text{ °C (37.1 °F)}$

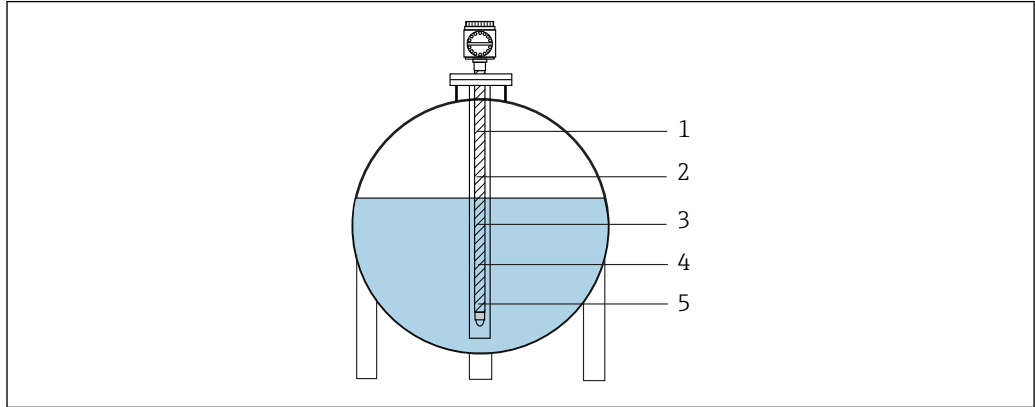

A0038546

8 Standard calculation method for liquid temperature

- 1 Element No.5: 4.5 °C (40.1 °F) (T5)
- 2 Element No.4: 4.0 °C (39.2 °F) (T4)
- 3 Element No.3: 2.0 °C (35.6 °F) (T3)
- 4 Element No.2: 3.0 °C (37.4 °F) (T2)
- 5 Element No.1: 3.5 °C (38.3 °F) (T1)

Advanced calculation method

Average temperature is calculated by adding a corrective factor for unequal volume distribution.

Formula: $(T1 \cdot V1 + T2 \cdot V2 + T3 \cdot V3) / (V1 + V2 + V3) = \text{Average temperature}$

i Parameters that are related to V = additional volume factors are determined in VH53, 54 and 55.

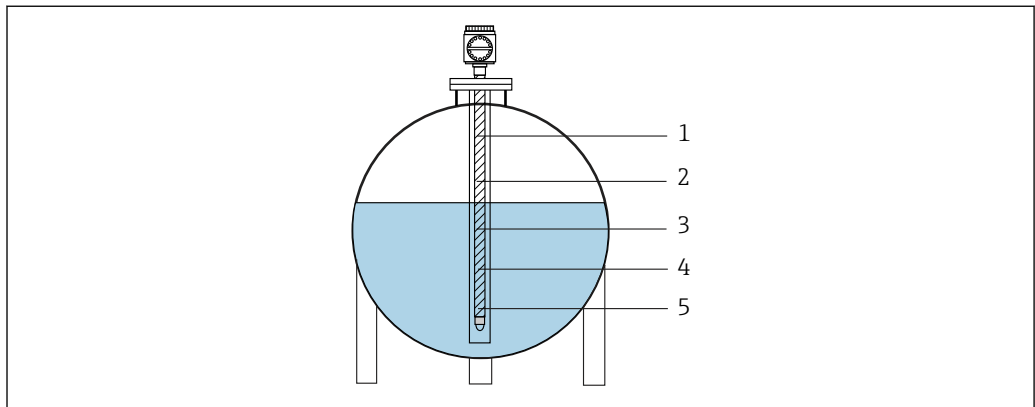

A0038546

9 Standard calculation method for liquid temperature

- 1 Element No.5: 4.5 °C (40.1 °F) (T5)
- 2 Element No.4: 4.0 °C (39.2 °F) (T4)
- 3 Element No.3: 2.0 °C (35.6 °F) (T3)
- 4 Element No.2: 3.0 °C (37.4 °F) (T2)
- 5 Element No.1: 3.5 °C (38.3 °F) (T1)

Advanced calculation method 2

Average temperature is calculated by adding a corrective factor for unequal volume distribution.

Formula: $(3.5\text{ °C } (38.3\text{ °F}) \times 2 + 3.0\text{ °C } (37.4\text{ °F}) \times 3 + 2.0\text{ °C } (35.6\text{ °F}) \times 4) / (2 + 3 + 4) = 2.67\text{ °C } (36.8\text{ °F})$

 In the diagram below, □ represents V (volume factor).

$(3.5\text{ °C } (38.3\text{ °F}) \times 2 + 3.0\text{ °C } (37.4\text{ °F}) \times 3 + 2.0\text{ °C } (35.6\text{ °F}) \times 4) / (2 + 3 + 4) = 2.67\text{ °C } (36.8\text{ °F})$

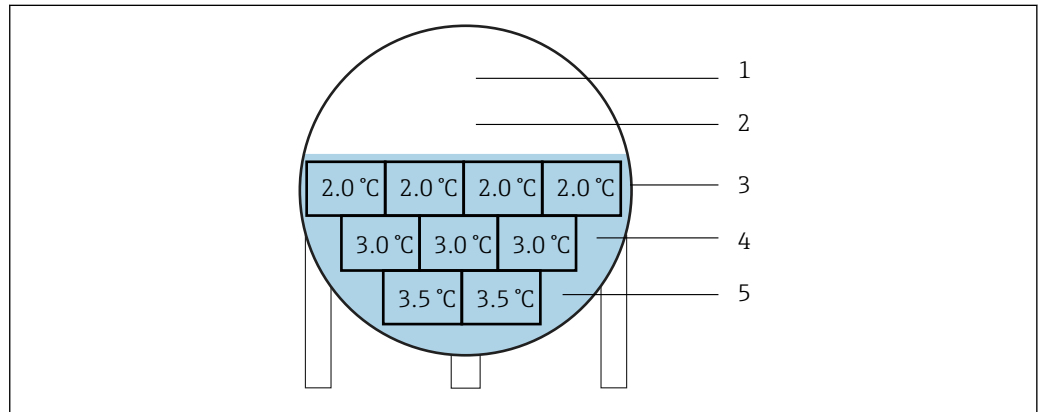

A0038547

 10 Advanced calculation method 2

- 1 Element No.5 : 4.5 °C (40.1 °F) (T5)
- 2 Element No.4: 4.0 °C (39.2 °F) (T4)
- 3 Element No.3: 2.0 °C (35.6 °F) (T3)
- 4 Element No.2: 3.0 °C (37.4 °F) (T2)
- 5 Element No.1: 3.5 °C (38.3 °F) (T1)

Code	Display	Details	
VH27	Multi Spot Type (Display array)	Item type	Selection
		Selection	Spot
			Multi
		Displays individual temperature measurement elements.	
The element array in a temperature probe is selected. This function is particularly required if an average temperature probe other than NMT539 is connected to the NMT539 converter-only version.			
 The "Spot" element array must always be selected in the converter + temperature probe version. Selecting the parameter to "Multi" will prevent accurate calculations. When several elements are installed on each input cable in the probe, average temperature is calculated based on the sum of temperature measurement element values in the liquid phase and the sum of the number of elements.			

VH27 Multi Spot Type: Spot temperature of the display array

The formula

$$(T1 + T2 + T3) / 3 = 25.5 \text{ } ^\circ\text{C} (77.9 \text{ } ^\circ\text{F})$$

calculates the average temperature.

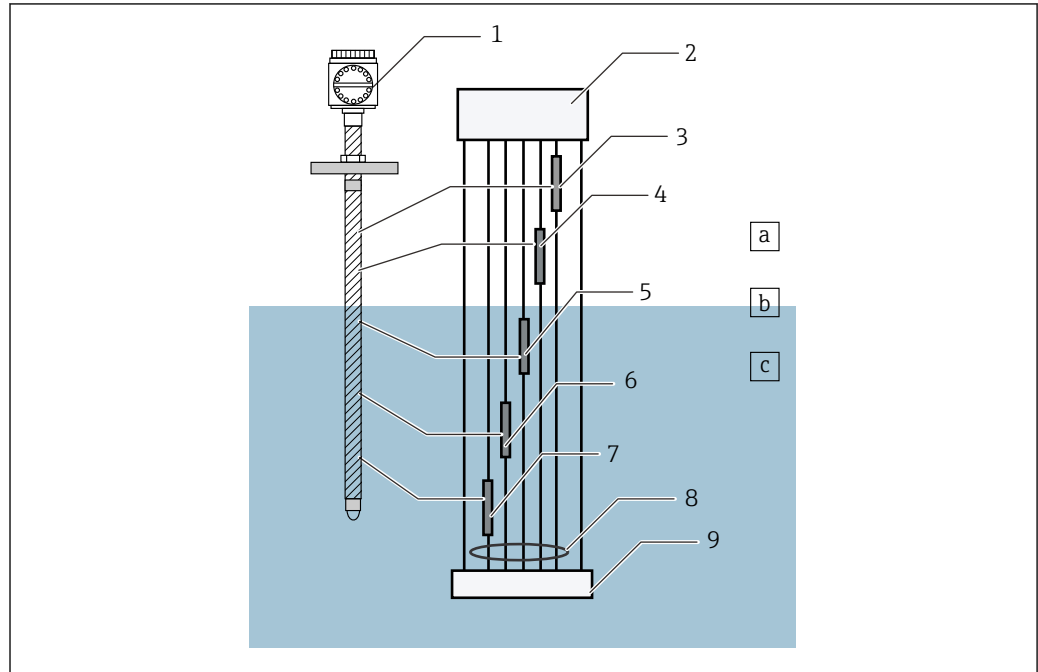

A0038548

11 Spot temperature

- a Gas (vapor phase)
- b Level
- c Liquid phase
- 1 NMT539
- 2 Converter
- 3 Pt100 element No.5: 2.45 °C (76.1 °F) (T5)
- 4 Pt100 element No.4: 24 °C (75.2 °F) (T4)
- 5 Pt100 element No.3: 26.0 °C (78.8 °F) (T3)
- 6 Pt100 element No.2: 25.5 °C (77.9 °F) (T2)
- 7 Pt100 element No.1: 25.0 °C (77.0 °F) (T1)
- 8 Input signal cable
- 9 Probe bottom

VH27 Multi Spot Type: Multi temperature of the display array

When elements with unequal lengths are installed on each input cable, out of the elements that are submerged in the liquid phase, the temperature measurement element in the liquid phase that is the closest to the liquid level is considered the average temperature.

The average liquid temperature is the element temperature (Element No.3: 26.0 °C (78.8 °F) (T3)) of the liquid phase that is the closest to the liquid level.

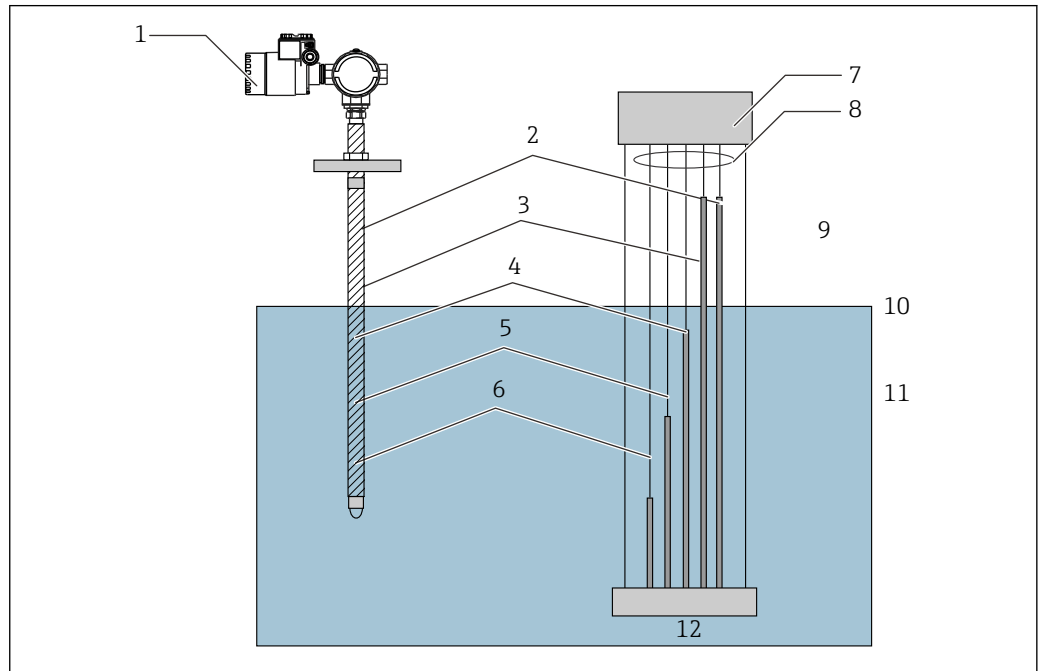

A0038549

12 Multi temperature

- 1 NMT539 converter-only type + Other brand's average temperature probe
- 2 Pt100 element No.5: 2.45 °C (76.1 °F) (T5)
- 3 Pt100 element No.4: 24 °C (75.2 °F) (T4)
- 4 Pt100 element No.3: 26.0 °C (78.8 °F) (T3)
- 5 Pt100 element No.2: 25.5 °C (77.9 °F) (T2)
- 6 Pt100 element No.1: 25.0 °C (77.0 °F) (T1)
- 7 To converter
- 8 Input signal cable
- 9 Gas (vapor) phase
- 10 Level
- 11 Liquid phase
- 12 Probe bottom

5.3.4 Upper and lower limits of temperature measurement elements: VH28-VH29

Code	Display	Details	
VH28	Lower Limit (Minimum temperature measurement element value)	Item type	Read / Write
		Default	-20.5 °C (-4.9 °F)
		Range	-999.9 to 999.9 °C (-1 767.82 to 1 831.82 °F)
		The lower limit of a temperature measurement element is set and used as a reference for determining an element short circuit.	
VH29	Upper Limit (Maximum temperature measurement element value)	Item type	Read / Write
		Default	245 °C (473 °F)

Code	Display	Details	
		Range	-999.9 to 999.9 °C (-1767.82 to 1831.82 °F)
		The upper limit of a temperature measurement element is set and used as a reference for determining an element short circuit.	

5.3.5 Element position 1: VH30-VH39

Code	Display	Details	
VH30-VH39	Position 1-10 (Element positions 1 to 10)	Item type	Read / Write
		Range	0 to 99999 mm
		Displays individual temperature measurement elements.	
		Sets the element position from the bottom of the tank. Calculation is automatically performed if "Equal" was selected as the element interval in VH85. If "Unequal" was selected, all element positions must be entered manually.	

5.3.6 Element position 2: VH40-VH49

Code	Display	Details	
VH40-VH45	Position 11-16 (Element positions 11 to 16)	Item type	Read / Write
		Range	0 to 99999 mm
		Displays individual temperature measurement elements.	
		Sets the element position from the bottom of the tank. Calculation is automatically performed if "Equal" was selected as the element interval in VH85. If "Unequal" was selected, all element positions must be entered manually.	
VH46	Hysteresis Width (Hysteresis width)	Item type	Read / Write
		Default	10 mm (0.39 in)
		Range	0 to 99999 mm
		Sets the hysteresis of an element switch position. Hysteresis entered as an offset value can prevent hunting caused by fluctuations of the level surface. This changes according to the range of fluctuations.	
VH47	Clear Memory (Memory deletion)	Item type	Selection
		Default	None (0)
		Range	0 to 99999 mm
		Selection	None, Clear
		Resets the matrix parameter to the default setting.	
VH48	Gas Offset (Gas offset)	Item type	Read / Write
		Default	300 mm (11.81 in)
		Range	0 to 99999 mm
		When a temperature element in the gas (vapor) phase is within the shown range below, it is not used for average gas temperature calculations.	

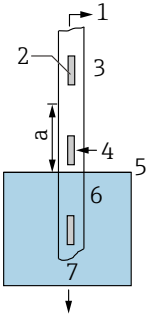
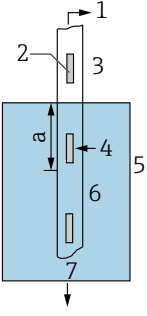

Code	Display	Details						
		<div style="text-align: center;">  </div> <p style="text-align: right; font-size: small;">A0038550</p> <p>13 Gas offset</p> <p><i>a</i> VH48 gas offset 300 mm (11.81 in) (Default)</p> <p>1 To NMT539 converter 2 Temperature element 3 Gas phase 4 Exclusion range (see Note) 5 Level 6 Liquid phase 7 To tank bottom</p> <p>i Although temperature elements in this range are in the gas phase, they are excluded from average gas temperature calculations in order to avoid effects from the interface between the liquid phase and the gas phase.</p>						
VH49	Liquid Offset (Liquid offset)	<table border="1" style="width: 100%; border-collapse: collapse;"> <tr> <td style="width: 50%;">Item type</td> <td style="width: 50%;">Read / Write</td> </tr> <tr> <td>Default</td> <td>300 mm (11.81 in)</td> </tr> <tr> <td>Range</td> <td>0 to 99 999 mm</td> </tr> </table> <div style="text-align: center; margin-top: 20px;">  </div> <p style="text-align: right; font-size: small;">A0038551</p> <p>14 Liquid offset</p> <p><i>a</i> VH48 gas offset 300 mm (11.81 in) (Default)</p> <p>1 To NMT539 converter 2 Temperature element 3 Gas phase 4 Exclusion range (see Note) 5 Level 6 Liquid phase 7 To tank bottom</p> <p>i Although temperature elements in this range are in the liquid phase, they are excluded from average liquid temperature calculations in order to avoid effects from the interface between the liquid phase and the gas phase.</p>	Item type	Read / Write	Default	300 mm (11.81 in)	Range	0 to 99 999 mm
Item type	Read / Write							
Default	300 mm (11.81 in)							
Range	0 to 99 999 mm							

5.3.7 Advanced temperature: VH50-VH59

Code	Display	Details	
VH53	Element Point (Element point)	Item type	Selection
		Default	0
		Selection	0-15 (Element No.1 = 0, Element No. 16 = 15)
		Selects the number of elements for "Advanced" average temperature calculations in VH26. The positions of the selected elements are displayed in VH54 "Element Position," and additional volume factors can be modified in VH55 "Element Volume."	
VH54	Element Position (Element position)	Item type	Read only
		Range	0 to 99999 mm
		Displays the position of the element that was selected in VH53.	
VH55	Element Volume (Element volume)	Item type	Read only
		Range	1 to 99999.9
		Sets the additional volume factor for the element that was selected in VH53. Additional volume can be added to individual elements for advanced average temperature calculations (for details, see "VH26: Selec. Ave Method").	

5.3.8 Temperature adjustment: VH70-VH79

Code	Display	Details	
VH70	Element Select (Element number assignment)	Item type	Selection
		Range	0 to 19
		The element number for performing temperature adjustments is selected (Element 0-15 = Element 1-16, 19 = Reference 100 Ω resistance).	
VH71	Zero Adjust (Zero adjustment of temperature measurement element)	Item type	Read / Write
		Default	0
		Range	-1000.0 to 1000.0
		Performs zero adjustment for individual elements that were selected in VH70. Unlike a standard temperature device, the reading value can be adjusted when the measured temperature shows minor correction values.  If element No.2 displays 25.4 °C (77.72 °F) and a standard temperature device displays 25.2 °C (77.36 °F), the matrix is set to -0.2. Once set, the correction value of element No.2 based on the actual measured value will be -0.2 °C (31.6 °F).	
VH72	Adjust Span (Adjustment of temperature measurement element span)	Item type	Read / Write
		Default	1
		Range	0.8 to 1.2
		Span adjustment is applied to all installed temperature measurement elements. This correction value is multiplied by the actual measured values.	
VH73	Temperature X (Temperature X)	Item type	Read only
		Temperature of the elements that were selected in VH70. Also displays each temperature measurement element that was displayed in VH10-VH25. The value is calculated based on the following formula: VH73: Temperature X = Unadjusted temperature x span (VH72) + Zero offset (VH71)	



Code	Display	Details	
VH74	Position X (Element position)	Item type	Read / Write
		Range	0 to 99 999 mm
		Position of the elements that were selected in VH70. If "Unequal" was selected in VH85, the position of each element can be set here.	
VH75	Resistance X (Element resistance)	Item type	Read only
		Shows the measured resistance for elements that were selected in VH70.	
VH76	Resistance Adj. (Element resistance adjustment)	Item type	Read / Write
		Default	0
		Range	-1 000.0 to 1 000.0
		Adjusts the resistance of elements selected in VH70. Minor resistance adjustments can be applied on the reading value.  Under identical environmental conditions, if the selected element No.5 displays 100.3 Ω and a standard high-precision resistor displays 100 Ω, -0.3 is set in this matrix. Once set, the correction value of element No.5 based on the actual measured value will be -0.3 Ω. Be careful when configuring this setting in VH76, as it will apply to all elements.	
VH77	Element Type (Element type)	Item type	Selection
		Selection	Pt100, Cu90, Cu100, PtCu100, JPt100
		The element conversion formula is selected for when another brand's average temperature probe is connected to the NMT539 converter-only version.  CAUTION Changing the parameters: NMT539 converter + temperature probe version is comprised of spot, element array and PT100 element types. ► Changing the parameters may cause erroneous calculations or unnecessary error displays.	
	Element conversion formula	Pt100 (formula above 0 °C): $R = -0.580195 \times 10^{-4} \times T^2 + 0.390802 \times T + 100$	
		Pt100 (formula below 0 °C): $R = -4.2735 \times 10^{-10} \times T^4 + 4.273 \times 10^{-8} \times T^3 - 0.58019 \times 10^{-4} \times T^2 + 3.90802 \times T + 100$	
		Cu90: $R = 0.3809 \times T + 90.4778$	
		Cu100: $R = 0.38826 \times T + 90.2935$	
		PtCu100: $R = 3.3367 \times 10^{-7} \times T^3 - 2.25225 \times 10^{-5} \times T^2 + 0.38416 \times T + 100.17$	
		R: Resistance, T: Temperature	
	VH78	Average Number (Sampling number)	Item type
Default			1
Range			1 to 10
The number of resistance samplings from all temperature measurement elements can be changed, including that of the reference resistance installed on the circuit of the main unit.  Increasing the sampling number will allow for a more accurate measurement, but it will slow down the device's overall scan time. Element selection frequency: Approx. 2 seconds/element, sampling maximum element number 21 (Number of elements: 16, Internal reference resistance: 5)			
VH79	Protect Code (Access code)	Item type	Read / Write
		Default	0



Code	Display	Details	
		Range	0 to 999
		Access code 530 enables selection and writing.	

5.3.9 Device setting 1: VH80-VH89

Code	Display	Details	
VH80	Present Error (Error information)	Item type	Read only
		Screen where error information is displayed. The following error codes will be displayed. For details, refer to "Troubleshooting" in the separate BA1025G operating instructions.	
		Error code	
		0	No error presence
		1	Common line open
		3	#1 element open
		4	#1 element short
		5	#2 element open
		6	#2 element short
		7	#3 element open
		8	#3 element short
		9	#4 element open
		10	#4 element short
		11	#5 element open
		12	#5 element short
		13	#6 element open
		14	#6 element short
		15	#7 element open
		16	#7 element short
		17	#8 element open
		18	#8 element short
		19	#9 element open
		21	#9 element short
		21	#10 element open
		22	#10 element short
		23	#0 element over range
		24	Memory defect (ROM)
		25	#11 element open
		26	#11 element short
		27	#12 element open
		28	#12 element short
		29	Element exposed (liquid level below #1 element position)
		32	Low power supply
		33	#13 element open
		34	#13 element short
		35	#14 element open
36	#14 element short		

Code	Display	Details	
		37	#15 element open
		38	#15 element short
		39	#16 element open
		40	#16 element short
		41	Memory defect (RAM)
		42	Memory defect (EEROM)
		43	WB line open
		44	WB line short

Code	Display	Details	
VH81	Temperature Unit (Temperature unit)	Item type	Selection
		Default	°C
		Selection	°C, °F, K
		Screen used to select the temperature display unit. Based on the HART configuration, °C (HART code: 32), °F (HART code: 33), and K (HART code: 35) are available.  Leave this parameter in °C if you are changing the default °C in the host gauge (NMS8x, NMR8x, NRF81, NMS5, NMS7, NRF590, TMD1) to another unit.	
VH82	Element Number (Number of temperature measurement elements)	Item type	Read / Write
		Default	10 (NMT539 converter-only version)
		Range	1 to 16
		The number of available temperature measurement elements is entered. This function is mainly used with the NMT539 converter-only version.  Do not change the default parameter on the NMT539 converter + temperature probe version. The number of elements is predetermined by the customer. Changing the default parameter may cause erroneous calculations or unnecessary error displays. CAUTION Changing the parameters: Do not change the default parameter on the NMT539 converter + temperature probe version. The number of elements is predetermined by the customer. ▶ Changing the default parameter may cause erroneous calculations or unnecessary error displays.	
VH83	No. of Preambles (Number of preambles)	Item type	Read / Write
		Default	5
		Range	2 to 20
		Sets the number of preambles for HART communication. CAUTION Changing the value: Do not change the default value. ▶ This may cause erroneous calculations or unnecessary error displays.	
VH84	Distance Unit (Distance unit)	Item type	Selection
		Default	mm
		Selection	ft., m, inch, mm

Code	Display	Details	
		 <ul style="list-style-type: none"> ▪ Selects the level display unit. This applies to the display of VH02 "Liquid level" and VH50 "WB". Based on the configuration of HART, the available level units are: ft. (HART code: 44), m (HART code: 45), inch (HART code: 47) and mm (HART code: 49). ▪ Leave this parameter in mm if you are changing the default mm in the host gauge (NMS8x, NMR8x, NRF81, NMS5, NMS7, NRF590, TMD1) to another unit. 	
VH85	Kind of Interval (Element interval configuration)	Item type	Selection
		Default	Equal interval (NMT539 converter-only version)
		Selection	Equal interval, unequal interval
		Screen that selects the element interval. This function is used in the NMT539 converter-only version.	
		 <p>Changing the parameters: Do not change the default parameter on the NMT539 converter + temperature probe version. The number of elements and the position of each element is predetermined by the customer.</p> <ul style="list-style-type: none"> ▶ Changing the default parameter may cause erroneous calculations or unnecessary error displays. Do not change the parameters on the NMT539 converter + temperature probe version other than for repair purposes. 	
VH86	Bottom Point (Position of the bottom-point element)	Item type	Read / Write
		Default	500 mm (19.69 in)
		Selection	0 to 99999 mm
		The position of the bottom-point element from the tank bottom (element No.1) is entered. If "Equal interval" has been selected in VH85, the position of element No.1 is extremely important, as the rest of the elements' positions will be determined by the position of the bottom-point element.	
VH87	Element Interval (Element interval)	Item type	Read / Write
		Default	1 000 mm (39.37 in)(NMT539 converter-only version)
		Range	0 to 99999 mm
		Changing the element interval and setting the element position are only applied to reconfigure switching points for average temperature calculations. The physical positions of elements will not change.	
		 <p>The default setting is 1 000 mm (39.37 in) in the NMT539 converter-only version, but other default settings will depend on the ordered specifications.</p>	
VH88	Short Error (Output data from element short circuit)	Item type	Read / Write
		Default	-49.5
		Range	-49.5 to 359.5
		This data is output when the selected element short-circuits. The display format can be configured in VH92 "Error Display Select."	
VH89	Open Error (Output data when element is open)	Item type	Read / Write
		Default	359.0
		Range	-49.5 to 359.5
		This data is output when the selected element is open. The display format can be configured in VH92 "Error Display Select."	

5.3.10 Device setting 2: VH90-VH99

Code	Display	Details	
VH90	Device ID Number (Device ID number)	Item type	Read / Write
		Default	0
		Range	0 to 16 777 214
		Screen used for distinguishing the device ID when the NMT539 connects to a HART communication loop. NOTICE Device ID and HART address: When a device ID is changed, a communication error may occur due to inappropriate device ID and HART address combination. ▶ Ensure that the device ID and HART address are correct.	
VH91	Previous Error (Previous error)	Item type	Read only
		Displays the error history. The error messages are the same as those in VH80.	
VH92	Error Dis. Sel. (Error display selection)	Item type	Selection
		Default	0
		Selection	0: OFF 1: ON
		Selects the display of VH88 "Short Error Value" and VH89 "Open Error Value." OFF: VH88 and VH89 error messages are not sent to the host gauge. This function automatically excludes defective elements in average temperature calculations. ON: Error messages are sent to the host gauge. As a result, the error codes of VH88 and VH89 will appear on the host gauge's default screen, and sent to the upper receiver as well.	
VH93	Custody Mode (Custody mode)	Item type	Read only
		Default	Configured at the factory according to specifications.
		 The overwrite protection of hardware is located on the main CPU board (CN3 connector).	
VH94	Polling Address (Polling address)	Item type	Read / Write
		Default	2
		Range	1 to 15
		Polling address used in local HART communication.	
VH95	Manufacture ID (Manufacturer ID)	Item type	Read only
		Default	17 (Endress+Hauser)
		Screen showing the manufacturer ID.	
VH96	Software Version (Software version)	Item type	Read only
		Screen showing the installed software version.	
VH98	Below Bottom	Item type	Selection
		Default	0
		Selection	0: OFF 1: ON
		Displays an error when the liquid level drops below the bottom-point element. If "ON" is selected, error code 29 will be displayed in VH80 and VH91.	

Code	Display	Details	
VH99	Device Type Code (Device code)	Item type	Read only
		Screen displaying the device type. <ul style="list-style-type: none"> ▪ 184: Temperature measurement function ▪ 185: WB measurement function ▪ 186: Temperature + WB measurement function 	

5.4 WB measurement

HART device code 185 is exclusively for WB measurement function. Available parameters and functions are as follows. The name of the HART device will be displayed in the default header, and the selected HART device code will appear in VH99 "Device Type Code."

Devices with a temperature measurement function as specified by product order codes are as follows.

Measurement function 2: Converter + WB probe

5.4.1 Element position: VH40-VH49

Code	Display	Details	
VH47	Clear Memory (Memory deletion)	Item type	Selection
		Default	None (0)
		Range	0 to 99999 mm
		Selection	None, Clear
		Resets the matrix parameter to the default setting.	

5.4.2 WB primary and advanced temperature: VH50-VH59

Code	Display	Details	
VH50	Water Level (WB)	Item type	Read only
		Displays the measured "Water level." These are measured values that were calculated using the following formula: $VH50 = \left[\frac{(VH52 - VG60) \times VH59}{VH63} \right] + VH58$	
VH51	Capacitance (Capacitance)	Item type	Read only
		Range	<ul style="list-style-type: none"> ▪ 1 000 mm probe: 10 to 10 000 pF ▪ 2 000 mm probe: 10 to 2 200 pF
		Screen displaying the WB probe capacitance based on the frequency.	
VH52	WB Frequency (WB frequency)	Item type	Read only
		Range	1 200 to 4 500 Hz
		Screen displaying the WB probe measurement frequency.	
VH57	Sel. Water Span (WB probe length)	Item type	Selection
		Selection	1 000 mm, 2 000 mm
		Screen for selecting the WB probe length.	
VH58	Offset Water (WB offset)	Item type	Read / Write
		Default	Approx. 100 to 110 Set individually at the factory.

Code	Display	Details	
		Range	-200 to 2 000
		Screen for WB offset of the measured values. There are two methods: Use the scale	
		<ul style="list-style-type: none"> For measured WB value 530 mm (20.87 in) and manual dipping value 730 mm (28.74 in): By entering VH58's default value + 200, offset + 200 mm (7.87 in) can be corrected. (For default 110 mm (4.33 in), at + 200 mm (7.87 in) set 310 mm (12.2 in)). 	
		Adding a WB probe position according to specification code	
		<ul style="list-style-type: none"> By default 110 mm (4.33 in), the distance between the bottom of a WB probe and the tank floor (or the datum plate) is 200 mm (7.87 in): Set to 110 mm (4.33 in) + 200 mm (7.87 in) = 310 mm (12.2 in). 	
VH59	Water Span (Water span adjustment)	Item type	Read / Write
		Default	1
		Range	0.1 to 99.9
		Adjusts the linearity of WB probe capacitance. The adjustment is used to correct WB properties with slight linear slope.	
VH60	Empty Frequency (Empty frequency (Frequency of VH58))	Item type	Read / Write
		Default	Approx. 1 800 to 2 200 Set individually at the factory.
		Range	0 to 9 999 Hz
		If a WB probe is in the liquid (oil) phase (NMT539 WB probe is not touching the water phase), the measured frequency (VH52 value) is entered.	
VH63	Water Factor (Frequency per unit liquid level)	Item type	Read only
		Displays the liquid's vertical motion per 1 mm in Hz (frequency) as WB probe linearity. Calculation is performed based on the following formula: (VH61 Full Frequency - VH60 Empty Frequency) / VH62 Probe Length = VH63 Water Factor	

5.4.3 WB adjustment and operation power: VH60-VH69

Code	Display	Details	
VH60	Empty Frequency (Empty frequency (Frequency of VH58))	Item type	Read / Write
		Default	Approx. 1 800 to 2 200 Set individually at the factory.
		Range	0 to 9 999 Hz

If a WB probe is in the liquid (oil) phase (NMT539 WB probe is not touching the water phase), the measured frequency (VH52 value) is entered.

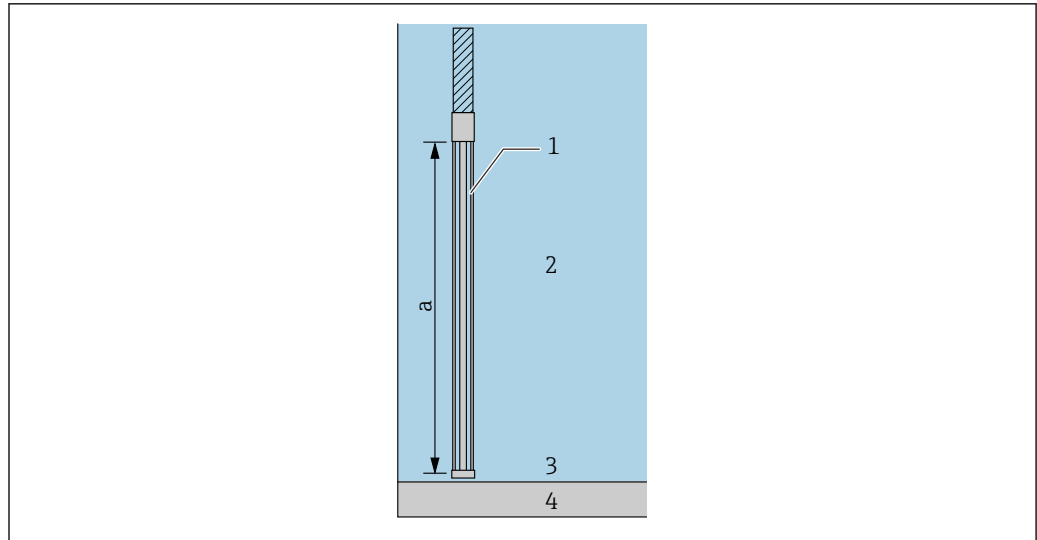

A0038552

15 Measurement frequency input 1

- a Measurement range: 1000 or 2000
- 1 WB probe
- 2 Liquid phase (oil)
- 3 Interface (oil and water)
- 4 Water phase

Code	Display	Details	
VH61	Full Frequency (Frequency at full tank)	Item type	Read / Write
		Default	Approx. 3 600 to 4 400 Set individually at the factory.
		Range	0 to 9 999 Hz

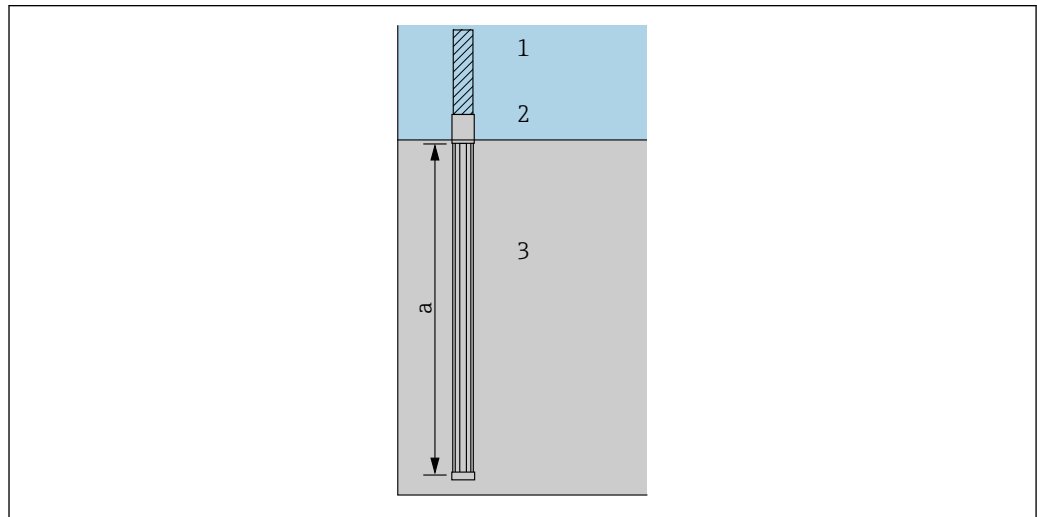

A0038553

16 Measurement frequency input 2

- a Measurement range: 1000 or 2000
- 1 Liquid phase (oil)
- 2 Interface (oil and water)
- 3 Water phase

Code	Display	Details	
VH62	Probe Length (WB probe length)	Item type	Read / Write
		Default	Approx. 800 to 1800 mm Set individually at the factory.
		Range	1 to 9999 mm

This screen is for entering the WB probe calibration distance (length).

Formula: (VH61 - VH60) / VH62 = VH63

Example of factory default setting:

- VH57 = 1 000 mm
- VH58 = 108.1 mm
- VH60 = 2 127.4 Hz
- VH61 = 4 291.8 Hz
- VH62 = 797.2 mm
- VH63 = 2.71 Hz/mm

i The default setting of probe length is approx. 800 mm or approx. 1800 mm. Factory calibration is performed by setting a completely anhydrous state (WB: 0 mm) in VH60 (Empty Frequency). Furthermore, probe linearity is assigned in VH63 "Water Factor," and a completely anhydrous setting (or WB above 1 000 mm or 2 000 mm) is set in VH61 "Full Frequency."

(4500 to 1200 Hz) / 1000 mm = 3.3 Hz / 1 mm

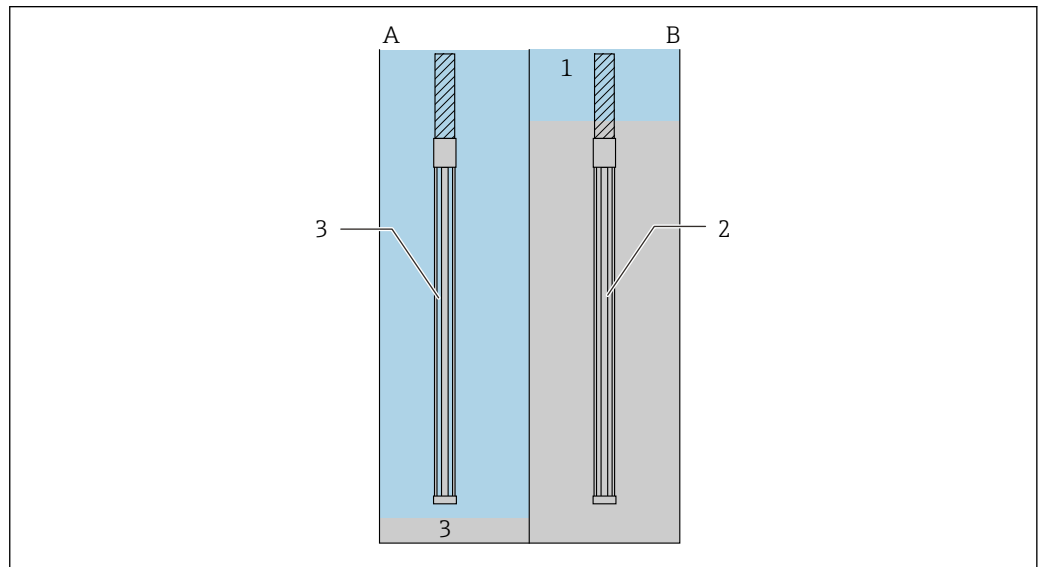

17 WB probe length

- A Reading value: Empty frequency: 1 200 Hz WB: 0 mm
- B Reading value: Full frequency: 4 500 Hz WB: 1 000 mm
- 1 Oil phase
- 2 Input range: Water phase
- 3 Water phase
- 4 Input range: Oil phase

Recalibration of tank during operation

Performing recalibration of an operating tank will take several processes as WB is determined using other tools. By measuring different water phases in two locations manually, WB probe calibration distance (VH62 Probe Length) can be calculated as follows.

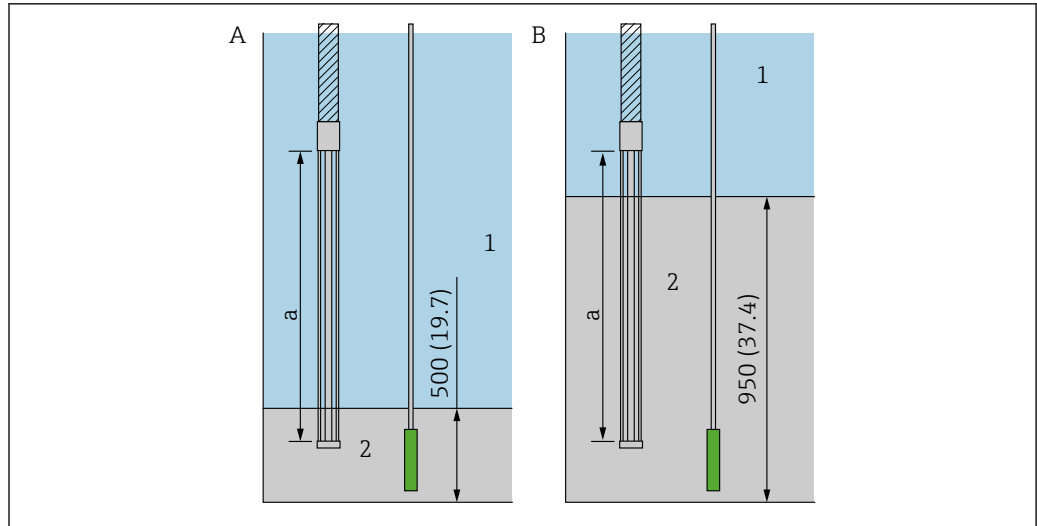

18 WB probe calibration Unit: mm (in)

- A Reading value: Empty frequency: 1 500 Hz WB: 500 mm
- B Reading value: Full frequency: 3 000 Hz WB: 950 mm
- a Measuring range: 1 000 or 2 000
- 1 Oil phase
- 2 Water phase

Example: 950 mm (37.4 in) - 500 mm (19.7 in) = 450 mm (37.4 in)

Recalibrated WB probe linearity in operating tank

(3 000 Hz - 1 500 Hz) / 450 mm - 3.33 Hz / 1 mm (0.03 in)

- VH60 Empty Frequency: 1 500 Hz (Enter the VH52 value at 500 mm (19.7 in))
- VH61 Full Frequency: 3 000 Hz (Enter the VH52 value at 950 mm (37.4 in))
- VH62 Probe Length: 450 mm (Enter the calculated value)
- VH63 Water Factor: 3.33 Hz (Reference)

i The WB probe linearity in an actual in-tank condition may be different from the default condition. Liquid property (both oil and water), temperature inside the tank and the surrounding environment have a significant impact on probe linearity.

Code	Display	Details	
VH63	Water Factor (Frequency per unit liquid level)	Item type	Read only
		Displays the liquid's vertical motion per 1 mm (0.03 in) in Hz (frequency) as WB probe linearity. Calculation is performed based on the following formula: $(VH61 \text{ Full Frequency} - VH60 \text{ Empty Frequency}) / VH62 \text{ Probe Length} = VH63 \text{ Water Factor}$ i Using the Water Factor that has been determined based on the actual WB measurements under given parameters, change in distance can be calculated from the detection frequency.	
VH67	Common Voltage (Common voltage)	Item type	Read only
		Range	0 to 255 (0 to 3 V)
		Displays the operating voltage of the temperature measurement line (signal and common). Voltage across the common line (between 0 and 3 V) is converted into a range from 0 to 255.	
VH68	Output Current (Output current)	Item type	Read only
		Range	0 to 65535

Code	Display	Details	
		Set as the output current according to specifications.	
		<p>⚠ CAUTION</p> <p>Changing the parameters: The default value is adjusted at the time of shipping, and is determined based on the device's specifications.</p> <ul style="list-style-type: none"> Do not change the parameters as it will cause the device to malfunction. 	
VH69	Ref Voltage (Reference voltage)	Item type	Read / Write
		Default	10 (PTB type is approx. 93)
		Range	0 to 255
		Triggers a power supply failure alarm. In normal operating conditions, this is activated via a HART communication loop at a supply voltage of 15 V _{DC} or higher. If the consumed voltage decreases to 15 V _{DC} or lower, an error message is sent.	

5.4.4 Temperature adjustment: VH70-VH79

Code	Display	Details	
VH79	Protect Code (Access code)	Item type	Read / Write
		Default	0
		Range	0 to 999
		Selection	None, Clear
		Access code 530 enables selection and writing.	

5.5 Temperature + water bottom measurement

HART device code 186 is used for temperature measurement and WB measurement for an all-inclusive NMT539. Available parameters and functions are as follows. Details of these parameters are based on FieldCare.

The name of the HART device will be displayed in the default header, and the selected HART device code will appear in VH99 "Device Type Code" on the FieldCare display screen. The following two temperature measurement and WB measurement devices are available as specified by product order code.

Measuring functions

3	Converter + temperature probe + WB probe
5	Converter + temperature probe + WB probe (W&M certification)

See previous section for information on temperature measurement and water measurement.

5.6 Exclusion of WB temperature elements from average temperature calculation

There is a function that excludes temperature elements in water from average temperature calculations. If there is an error in WB measurement, WB will be 0 mm for average liquid temperature calculations.

5.7 WB (water bottom) level input from host

This function is available in V1.53 and later versions. If the specification does not have a WB probe, VH50 WB can be entered manually from the HART Master.

This function is available for specifications that do not have a WB probe. It will not be applied to multi-element calculations. If the WB probe error is resolved, the previous value will be used. It is 0 mm when the power is turned off or on.

Process for entering 876.5 mm (34.51 in) as a WB value:

1. Enter 129 in Device Specific Commands.
2. Enter 047 (0x047E/VH50) in Data (Hex).
 - ↳ 047E indicates variable address 1150.
3. Enter float value 445B2000.
 - ↳ It will show the WB value 876.5 mm (34.51 in).

This completes the input process.

i 31 indicates millimeter (mm).

The screenshot displays the HART Master interface for entering a WB value. It is divided into 'Request' and 'Response' sections. In the 'Request' section, the 'Command # (Decimal)' is set to 129 and the 'Byte Count' is 7. The 'Data (Hex)' field contains the hexadecimal value 047E31445B2000. In the 'Response' section, the 'Response Code (Decimal)' is 0, the 'Byte Count (Decimal)' is 9, and the 'Device Status (Decimal)' is 8. The 'Data (Hex)' field shows the response data: 04 7E 31 44 5B 20 00. A callout '1' points to the '31' in the hex data, which represents the unit in millimeters.

19 Screen 1

1 Variable address

Process for entering 2 345.6 mm (92.35 in) as a WB value:

1. Enter 145 in Device Specific Commands.
2. Enter 50 (VH50) in Data (Hex).
 - ↳ VH50 will be the matrix for NMT539, NMT532 and NCT530.
3. Enter the float value 4512999A.
 - ↳ It will show WB value 2 345.6 mm (92.35 in).

This completes the input process.

i 31 indicates millimeter (mm).

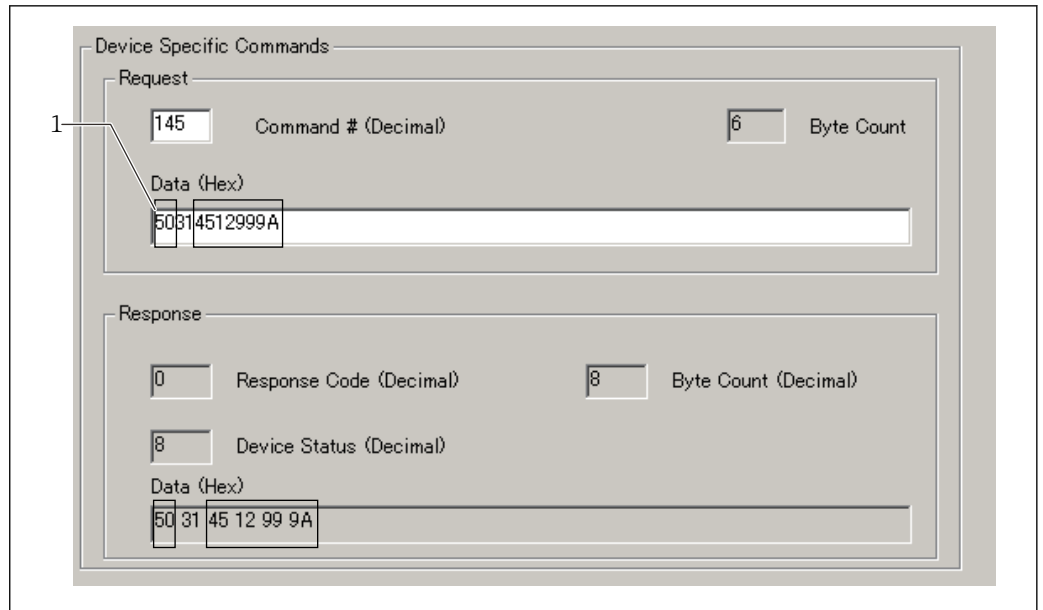

A0038558

20 Screen 2

1 VH number

5.8 Temperature element near the tank bottom

This function is available in V1.53 and later versions. Temperature elements that are less than 1 m (3.28 ft) from the tank bottom are handled as shown in the following table in average liquid temperature calculations. Refer to the following figures for Case 1 and Case 2 in the following table.

Case		Application to average temperature calculation for temperature element
1	Elements that are at 1 m (3.28 ft) or higher	Not applicable
2	The level is 1 m (3.28 ft) or higher but elements are below 1 m (3.28 ft)	Applicable
3	The level is below 1 m (3.28 ft), and the elements below that are below the level	Applicable
4	The temperature element is not in the liquid	Not applicable

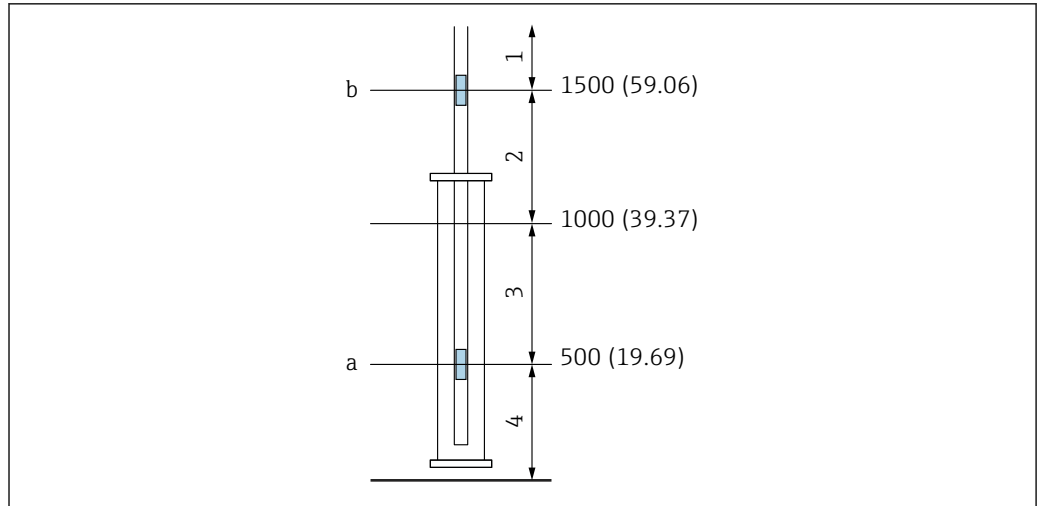

A0038559

21 Example of temperature elements near the tank bottom

- a Temperature element 1
- b Temperature element 2
- 1 Case 1
- 2 Case 2
- 3 Case 3
- 4 Case 4

- i** Case 1: If the liquid level is within this range, temperature element a will not be used in average liquid temperature calculations.
- Case 2 and 3: If the liquid level is within this range, temperature element a will be used in average liquid temperature calculations.
- Case 4: If the liquid level is within this range, none of the temperature elements will be used in average liquid temperature calculations.

5.8.1 Temperature adjustment: VH92

The following table shows the settings.

VH92 setting	Presence of liquid in tank	Temp. element open (disrupted)	Temp. element short (short circuit)	Average liquid temperature error output
ON	No	No	No	358 °C (676.4 °F)
	No	Yes	No	358 °C (676.4 °F)
	No	No	Yes	358 °C (676.4 °F)
	Yes	No	No	Average liquid temperature
	Yes	Yes	No	Open error set value (default 359 °C (678.2 °F))
	Yes	No	Yes	Short circuit error set value (default -49.5 °C (-57.1 °F))
OFF (Default)	No	No/Yes	No/Yes	Average gas temperature (The malfunctioning temperature element is skipped)
	Yes	No/Yes	No/Yes	Average liquid temperature (The malfunctioning temperature element is skipped)

5.9 Write-protection switch (write-protection plug)

When the write-protection switch in software version 1.53 or later is used, all parameters become write protected. In PTB specifications, this comes with the product.

 Do not disconnect and reconnect while the power is on.

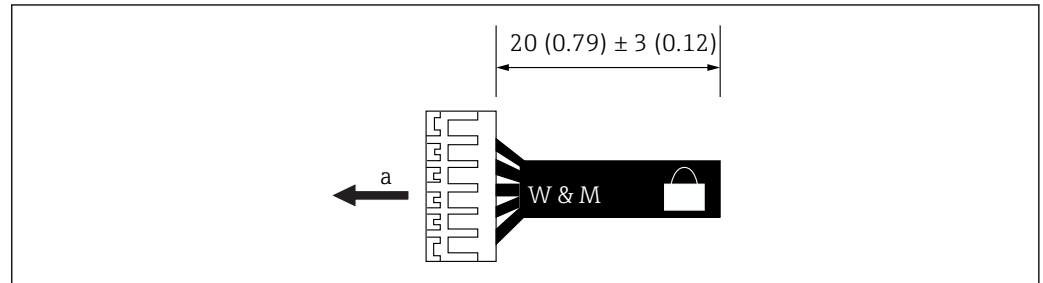

A0038560

 22 Write-protection switch

a To NMT539 CPU CN3

5.10 Module configuration

After replacing the electric housing module, parameters must be re-entered manually into the electric housing module to maintain proper operation. Check the following matrix parameters after replacing the electric housing module.

NMS5/NMS7 GVH	FieldCare / Details
443	Level select
450-459	Element position No. 1-9
470	Select point (elements 0-15)
474	Position X (element position that was set in GVH=470)
482	Element number
485	Kind of interval
486	Bottom point
487	Element interval (when selecting equal interval at GVH=485)

Index

Symbols

Application	8
Safety Instructions	
Basic	8
Operational safety	9
Measured materials	8
Declaration of Conformity	9
Requirements for personnel	8

C

CE mark	9
-------------------	---

D

Designated use	8
--------------------------	---

P

Product safety	9
--------------------------	---

W

Workplace safety	8
----------------------------	---

www.addresses.endress.com
