



Level



Pressure



Flow



Temperature



Liquid
Analysis



Registration



Systems
Components



Services



Solutions

Technical Information

Prothermo NMT539

Intrinsically safe multi-signal converter with precision average temperature and water bottom sensor for inventory control and custody transfer applications



Applications

The Prothermo NMT 539 is based on API(American Petroleum Institute) Manual of Petroleum Measurement Standard, Chapter 7, and enables high accuracy temperature measurement. At the same time, it is an intelligent average temperature sensor for tank gauging with an optional WB capacitance sensor at the bottom of the temperature probe.

For average temperature measurement, it consists of precision multi-spot Pt100 elements.

The NMT539 is a highly capable solution that provides both constant average temperature data and water interface data via local HART® communication.

For accurate inventory measurement, it is best suited connected to Endress+Hauser's Proservo NMS5/NMS7 or Tank Side Monitor NRF590 with Micropilot radar.

Features

- Intrinsically safe device allowing for the safest electrical configuration possible.
- Available in four different versions based on customer requirements:
 - Converter Only
 - Converter and Temperature probe
 - Converter, temperature and water bottom (WB) probe
- Converter is compatible with various element types in third party manufacturer temperature probes.
- Variety of process connections and cable entries available to meet worldwide classifications.

Table of Contents

Function and system design	3	Ex d NMS5 connection	20
Measurement system	3	TGM5/TMD1 terminal	21
System design	4	Terminal connection on the Tank Side Monitor NRF590	21
ATEX, FM, CSA...Ex i combination with Proservo NMS5	5	Operating condition : Environment	22
NMT 539 Converter + Temp. probe version	5	Ambient temperature range	22
ATEX, FM, CSA, TIIS ...		Storage temperature	22
Ex i combination with Tank Side Monitor NRF 590	6	Climate class	22
NMT 539 Converter + Temp. + WB version	6	Degree of protection	22
TIIS...Ex d[ia] combination with Digital transmitter TMD1	7	Electromagnetic compatibility	22
TIIS...Ex d[ia] combination with Servo gauge TGM5	8	Operating condition : Process	22
TIIS...Ex i combination with Proservo NMS5/NMS7 (Ex d) and Prothermo NMT539 (Ex i, high temp. specification)	8	Process temperature range	22
Input	9	Process pressure limits	22
Measured variables	9	Data transmission	22
Compatible element (Converter only version)	9	Mechanical construction	23
Number of elements	9	Type 1: Converter only version	23
Output	9	Type 1: Measuring function	23
Communication	9	Type 2: Converter only version	24
Alarm signal	9	Type 2: Measuring function	24
Output signal	9	Converter + average temperature probe version	25
Connection	9	Measuring function	25
Auxiliary energy	10	W&M function	25
Load HART®	10	Converter + average temperature probe + WB probe version	26
Cable entry	10	Measuring function	26
Supply voltage	10	WB probe design	27
Power consumption	10	Weight	27
Performance characteristics	11	Material	27
Temperature accuracy	11	Human interface	27
WB accuracy	11	Operation using ToF Tool, FieldCare	27
Reference operating conditions	11	Certificates and approvals	28
Maximum measured error	11	CE approvals	28
New module	11	Ex approvals	28
All-in-one program	11	PTB W&M approval	28
Operating condition : Installation	12	External standards and guidelines	28
Wiring	12	Ordering information	29
Process connection	12	Accessories	31
Installation height adjuster	12	Anchor weight (high profile, D120) mounting attachment option: B	31
WB blocking distance	12	Anchor weight (low profile, hexagon H41) mounting attachment option: C	31
Recommended installation height	13	Wire hook, Top anchor mounting attachment option: D,F	32
Recommended still pipe installation	14	Documentation	33
Installation equipment	14	Technical Information	33
Operating condition : wiring	17	Operating Instructions	33
TIIS Ex d[ia] wiring	17	Certificates	33
Example of Grounding cable construction (TIIS Ex d[ia])	17	Appendix	34
Connecting diagram (TIIS Ex d[ia])	18	Stainless Steel conversion table	34
Operating condition: terminal connection	19		
Ex ia NMT539 terminal	19		
ATEX, FM, CSA ... Ex d[ia] Proservo NMS5 terminal	19		
TIIS Ex d[ia] Prothermo NMT539 terminal	20		

Function and system design

Measurement system

The Prothermo NMT 539 is available in four different versions:

- Converter only
- Converter + Average temperature probe
- Converter + Average temp probe + Water bottom probe

The converter only version can be retrofitted without modifications onto existing third party average temperature probes, such as Whessoe Varec 9909 and 1700 and Weed Beacon MW type probes. The average temperature probe + converter inherits all the functionality of the former Prothermo NMT 535/536/537 series. The average temperature + WB + converter is the ultimate multi-function sensor, transmitting temperature and water interface level data along only one pair of local HART® signal cables to the host the Proservo NMS5 ,TGM5, TMD1 or NRF 590 Tank Side Monitor.

NMT 539 + WB operation principle (Converter + Temp + WB probe version)

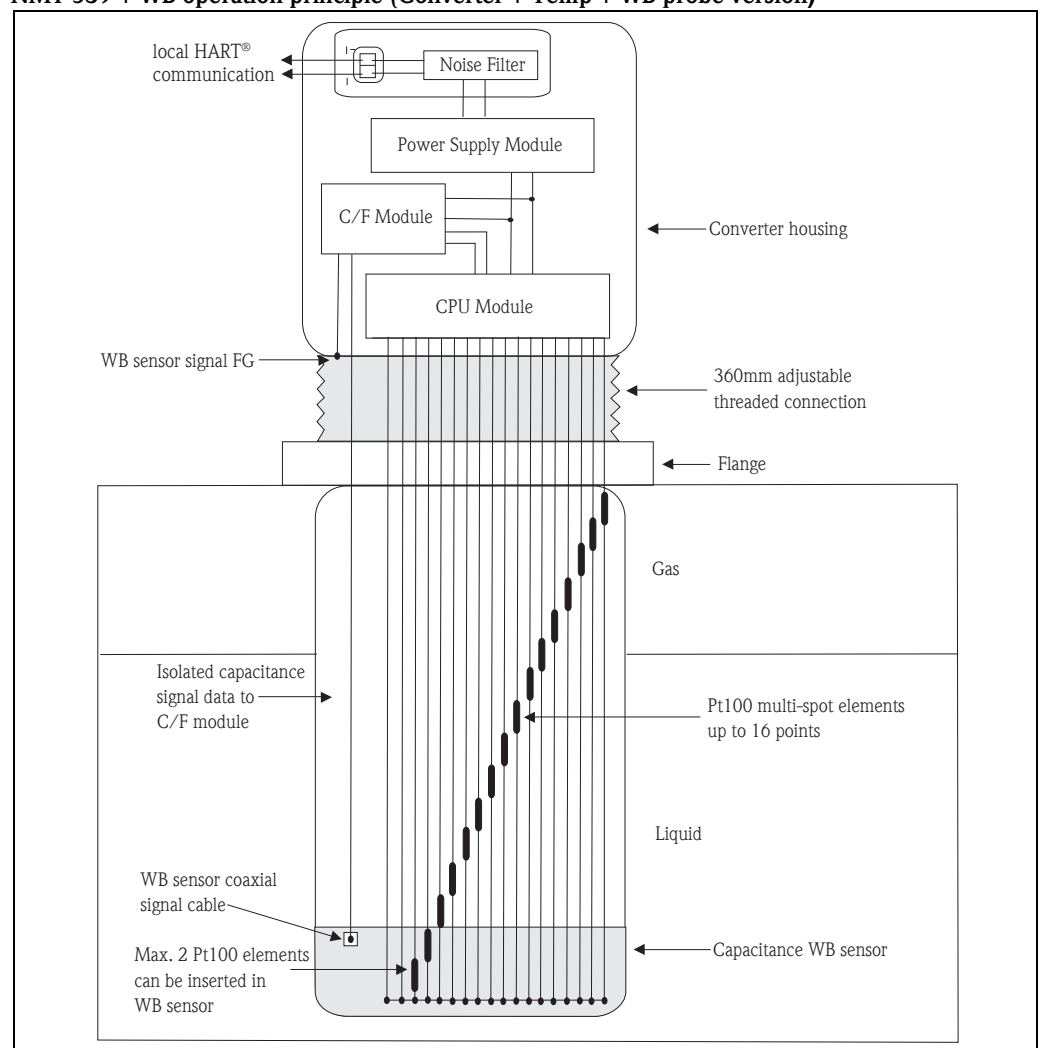

Note!

Different types of NMT 539, including "Converter only," "Coverter + average temperature" are simpler versions of the "Coverter + WB + temperature" probe.

System design

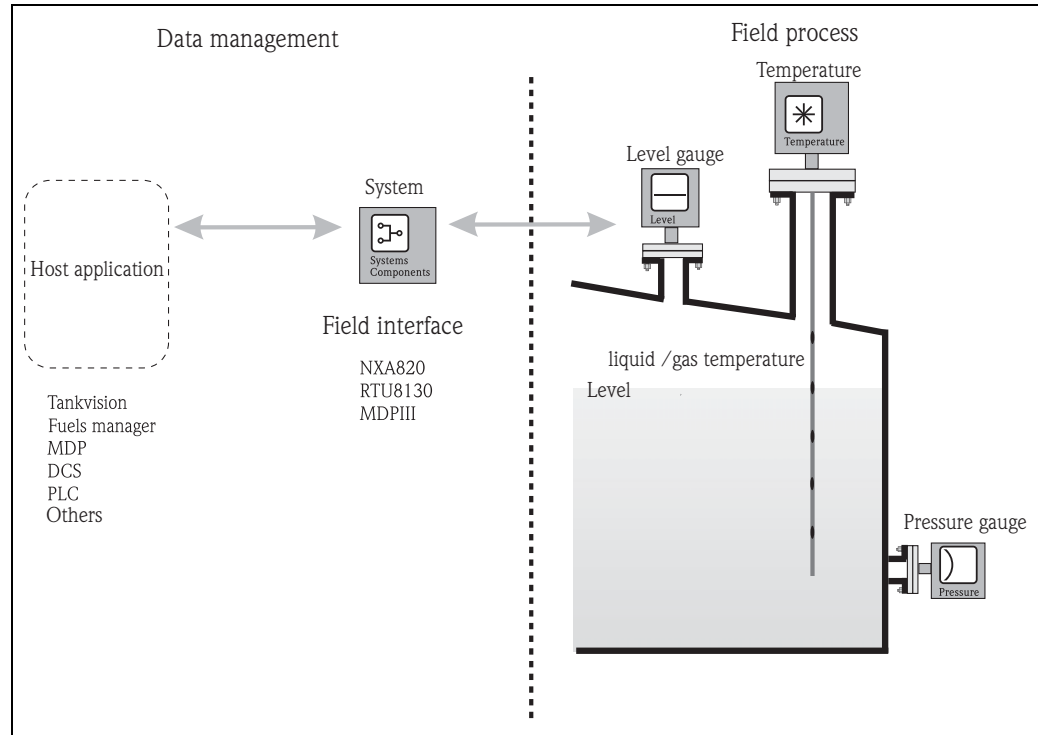

Endress+Hauser offers a wide range of solutions to integrate field data into your process management requirement.

The following diagrams describe some individual solutions according to various Ex concepts. For additional application requirements, contact your local Endress+Hauser representative.

ATEX, FM, CSA...Ex i combination with Proservo NMS5

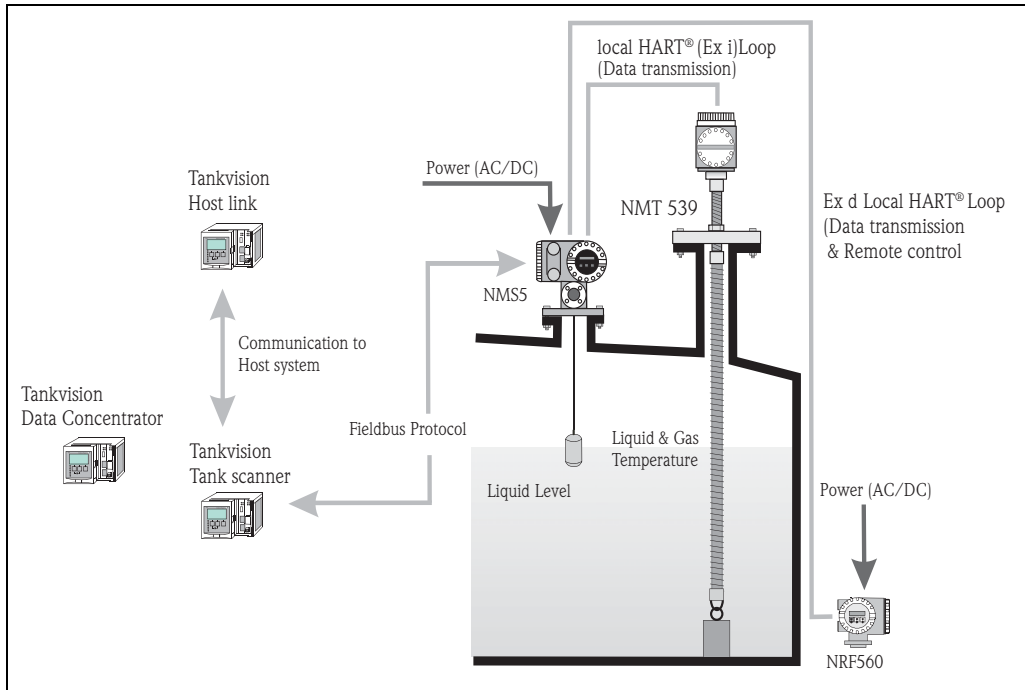

Note!
NMT539 connection on the drawing is only available to connect with NMS Ex d[i]a.

NMT 539 Converter + Temp. probe version

The Prothermo NMT 539 is the successor of the former NMT 535 Ex i version. For proper migration, the NMT 539 has inherited all the functionality and specifications of the NMT 535, including process connections, cable entries and wiring method.

Since the Proservo NMS5 already provides water interface measurement, the NMT 539 Converter + Average temperature may be the best version when used in combination with the Proservo. When the Converter + WB + Average temperature version is used in combination with the Proservo, the product in the tank will be thoroughly managed with level, continuous average temperature and water interface measurement.

Most configuration and parameter settings for the NMT539 can be performed via the Proservo NMS5 programming matrix.

The NMT 539 receives liquid level data from the Proservo, then calculates liquid and gas phase average temperature. Calculated data and basic information, including raw data for each temperature element and device status, are transmitted to the Proservo.



Note!
Since the Proservo is a multi-functional device (measurement and data transmission), the Promonitor NRF 560 acts as a tank side remote data indicator and controller for Proservo.

All gathered data in the interface unit is sent to inventory management software, such as Endress+Hauser's Tankvision, Fuelsmanager, Tank computer or directly sent to the customer's specific DCS or PLC.

ATEX, FM, CSA, TIIS ... Ex i combination with Tank Side Monitor NRF 590

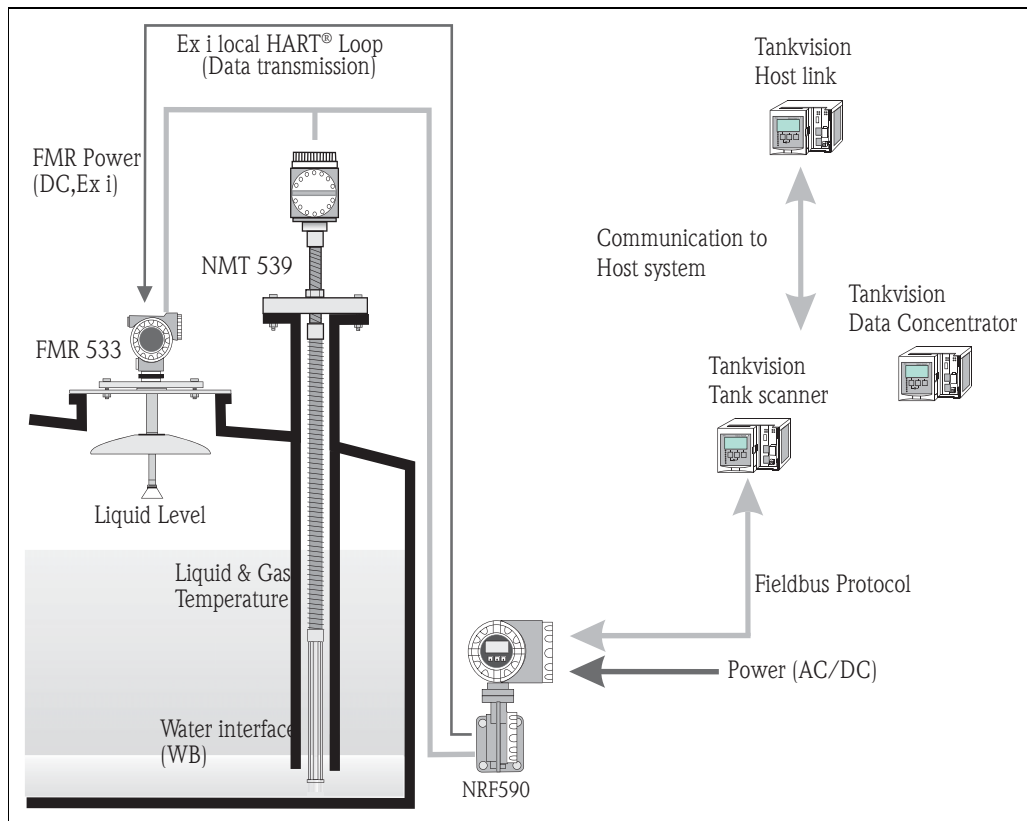

NMT 539 Converter + Temp. + WB version

The NMT 539 Converter + Temp. + WB is utilised effectively in combination with radar level gauging. Water interface, temperature and level measurement, with data collection and calculations via the NRF 590, allow for optimal inventory control. Basic functionality of the NMT 539 is displayed and configured on the NRF 590. Detailed NMT 539 functionality and data access can be performed by the ToF tool or FieldCare.

The NMT 539 receives radar level data from the NRF 590 and then calculates liquid and gas phase average temperature. Calculated and standard data, including temperature element raw data and device status, are transmitted to the NRF 590.

All gathered data in the interface unit is sent to inventory management software, such as Endress+Hauser's Tankvision, Fuelsmanager, tank computer or directly sent to the customer's specific DCS or PLC.

**TIIS...Ex d[ia]
combination with Digital
transmitter TMD1**

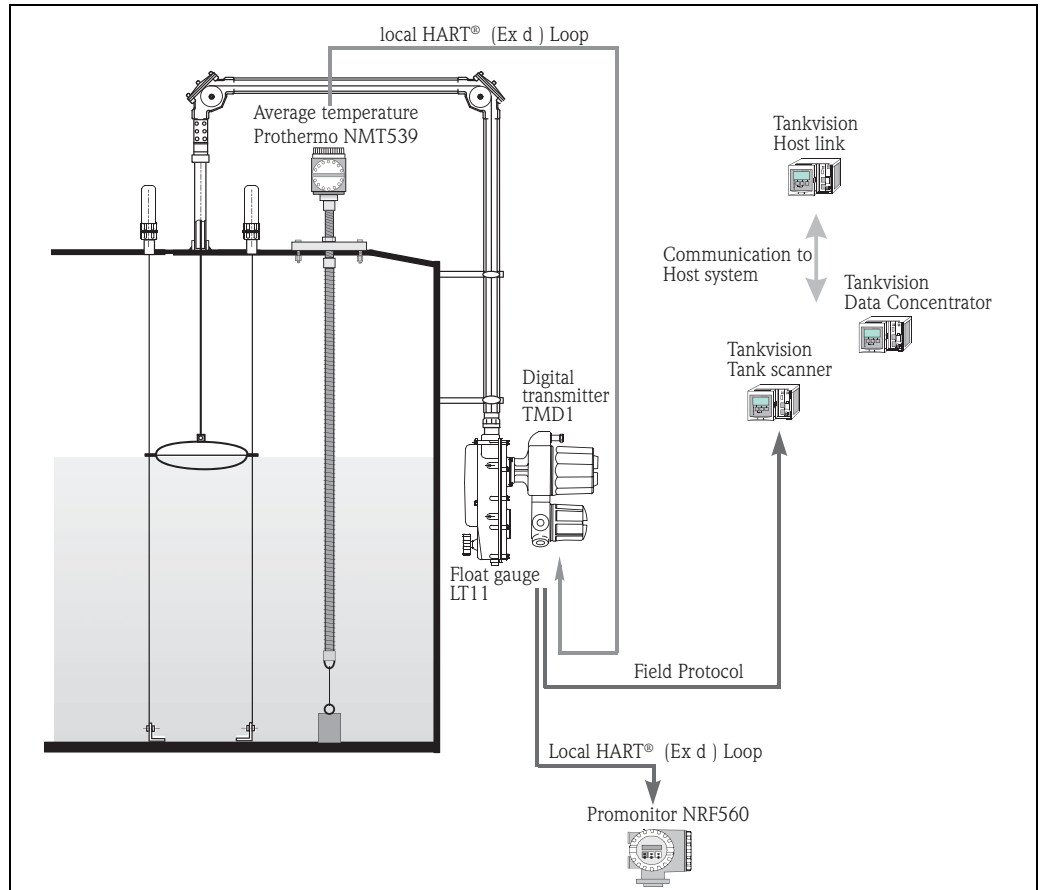

Average temperature data is transmitted to transmitter TMD1 via local HART® communication.



Note!

If NMT539 WB probe and NRF560 are used together, confirm supply voltage to TMD1 is stable 100 VAC or more.

**TIIS...Ex d[ia]
combination with Servo gauge
TGM5**

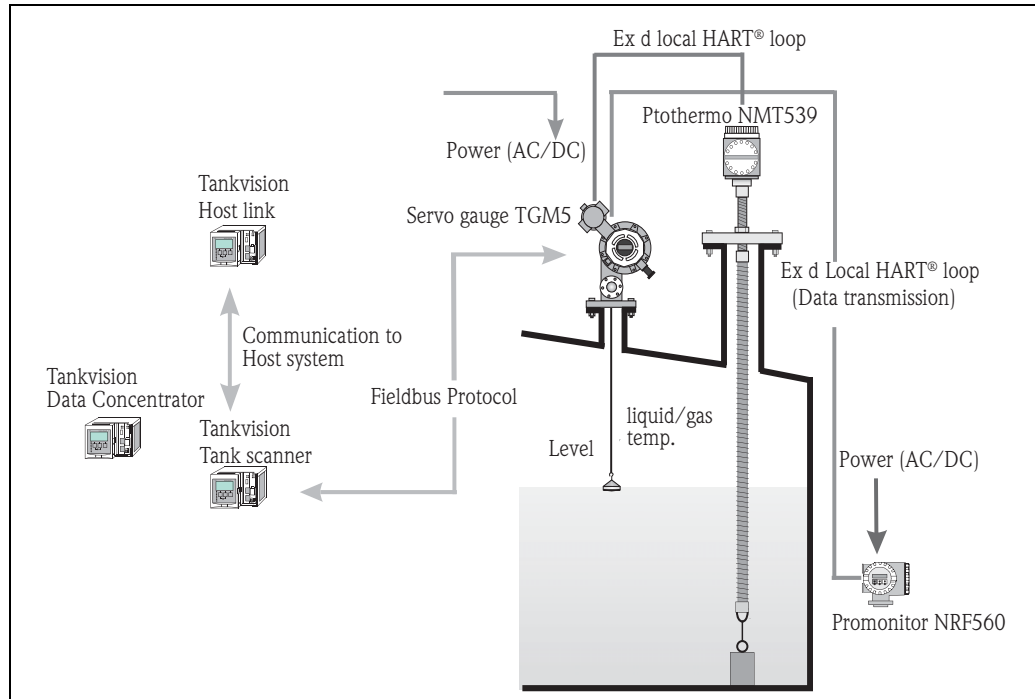

Note!

If NMT539 WB probe and NRF560 are used together, confirm supply voltage to servo gauge is stable 100VAC or more.

**TIIS...Ex i
combination with Proservo
NMS5/NMS7 (Ex d) and
Prothermo NMT539 (Ex i,
high temp. specification)**

Prothermo NMT539 high temperature specification is Ex i output. When using with Proservo NMS5/NMS7, Barrier Box NAB560 is required.

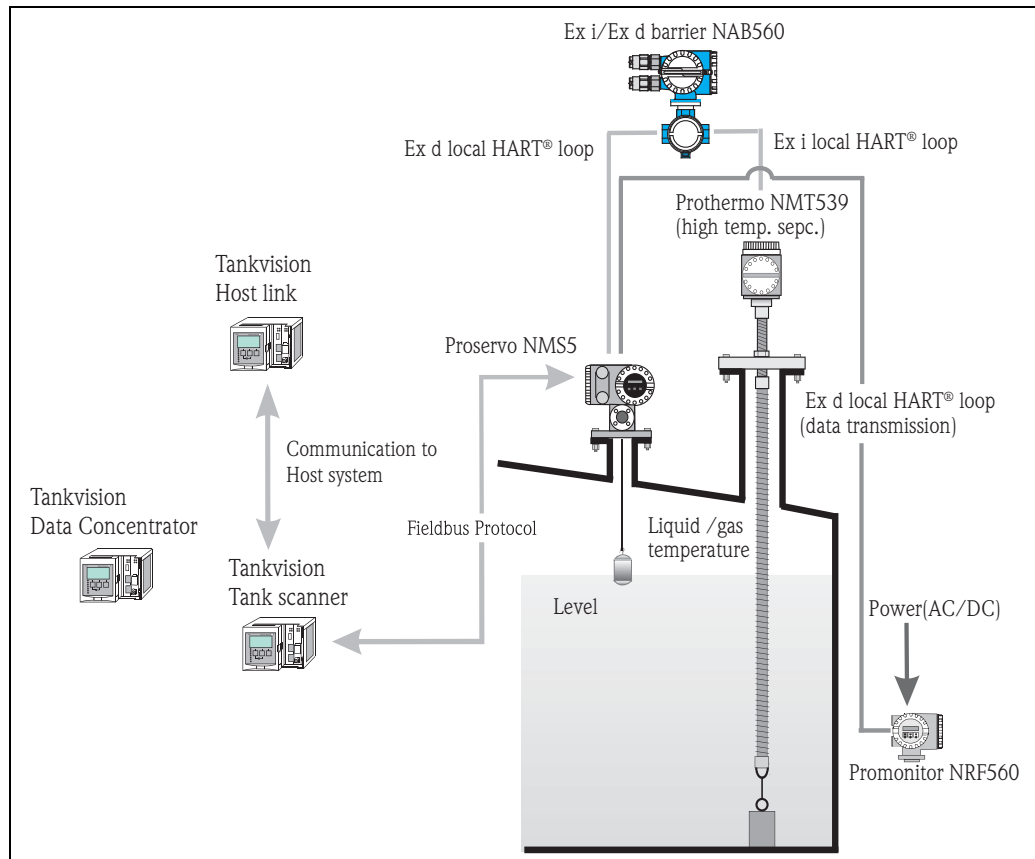

Input

Measured variables

Temperature measuring range:

Temperature conversion : -200 ...+235 °C (-328 ...+455 °F), (-170...+235°C TIIS)

Standard : -40...+100°C (-20...+100°C TIIS)

Wide range : -55...+235°C (-20...+235°C TIIS)

Cryogenic : -170...+60°C

Probe length : 40m or less

Water interface level (water bottom) range

Standard : 1m ...2m (3.3 ...6.6 ft)

Compatible element (Converter only version)

Pt100

Cu90

Cu100

PtCu100

JPt100

In case of TIIS, it is only Pt100 and JPt100.



Note!

NMT 539 Converter + Temp. version has only Pt100 elements installed. The element types above can be utilised in third party temperature probes, such as the Endress+Hauser 9909, 1700 or Weed Beacon MWR. Other manufacturer multi-resistant and multi-spot average temperature probes may be compatible.

Number of elements

2 to 16 can be connected

Output

Communication

2 wire, Endress + Hauser local HART® protocol to host commanding gauge

- Proservo NMS5/NMS7
- Tank Side Monitor NRF 590
- Digital Transmitter TMD1
- Servo Gauge TGM5

Alarm signal

Error information via the following interface and transmission digital protocol. Please refer to Operating Instructions of each device.

- Proservo NMS5/NMS7 ... BA1001N(BA01001G)
- Tank Side Monitor NRF590 ... BA256F(BA00256F), BA257F(BA00257F)

Output signal

- local HART® protocol

Connection

- Proservo NMS5/NMS7
- Tank Side Monitor NRF590
- Digital Transmitter TMD1
- Servo Gauge TGM5

Auxiliary energy

Load HART®	Minimum loading for local HART® circuit : 250Ω
Cable entry	<p>Wiring of the NMT 539 must meet explosion proof or intrinsically safe requirements. The following cable entries are available:</p> <ul style="list-style-type: none">■ Thread G 1/2■ Thread NPT 1/2■ Thread M 20 <p>Only G1/2 is selectable on TIIS Ex d[ia] and 2 cable glands SXC-16B are attached.</p>
Supply voltage	<p>DC16 ... 30V : Ex ia DC20 ... 24V : TIIS Ex d[ia] connectable only TGM5, TMD, NMS...Ex d</p>
Power consumption	<p>Ex ia: 6mA (Temperature measurement) 12mA (WB measurement)</p> <p>TIIS, Ex d[ia]: 8mA (Temperature measurement) 14mA (WB measurement)</p>

Performance characteristics

Temperature accuracy	<p>$\pm 0.1^{\circ}\text{C}$ or better (under the reference condition)*1</p> <p>Reference condition*1: Accuracy of RTD - Temperature conversion. Accuracy measurement shall be conditioned with precisely calibrated dial resistor or IEC class A Pt100 ohm temperature element.</p>
WB accuracy	<p>$\pm 2\text{mm}$ or less (under the reference condition)*2</p> <p>Reference condition*2: Measurement condition is based on 80% span of 1m probe in water / air interface at 25°C.</p> <p>The Factory default is adjusted based on DC (ϵ_r)=2.1</p>
Reference operating conditions	<ul style="list-style-type: none"> ■ Temperature = $+25^{\circ}\text{C}(77^{\circ}\text{F}) \pm 5$ (9°F) ■ Pressure = 1013 hPa (mbar) abs.(14.7 psi)± 20 hPa (mbar) (0.3 psi) ■ Relative humidity (air) = $65\% \pm 20\%$
Maximum measured error	<p>Typical statements for reference conditions, include linearity, repeatability, and hysteresis:</p> <ul style="list-style-type: none"> ■ Linearity: <ul style="list-style-type: none"> - Temperature: $\pm 0.15^{\circ}\text{C}$ (0.27°F) + element deviation (based on IEC class A standard) - WB: $\pm 2\text{mm} * 2$
New module	<p>The Prothermo NMT 539 employs a completely new electronic module compared to the previous NMT 535.</p>

	NMT 539	NMT 535
CPU Performance	16 bit	8 bit
Clock speed	2.7648 MHz	0.9216 MHz
Memory capacity (RAM)	20K bytes	176 bytes
EEPROM	2K bytes	256 bytes
Flash memory	256K bytes	16K bytes
Total # of print boards	4 (5 with Capacitance board)	5
Current consumption (Converter + temp. probe)	6mA@16VDCEx ia 8mA@16VDCEx d[ia]	10mA@16VDC

All-in-one program The powerful processor enables multi-function calculations under a single program. This means that there is no need for a variety of spare parts.

RTD Temperature calculation

The main CPU board now has all the required data processing functionality, including RTD - local HART[®] conversion. With the NMT 538, various programs were required depending on temperature element characteristics, such as Pt100, Cu90, Cu100 and PtCu100. The new NMT 539 has all the programs in one powerful processor.

Capacitance - local HART[®] signal conversion

A separate CF (Capacitance - Frequency) board can be connected directly to the CPU board when NMT 539 is equipped with WB sensor.

Operating condition : Installation

Wiring

Wiring of the NMT 539 must meet explosion proof or intrinsically safe requirements.

The following cable entries are available:

- Thread G 1/2"
- Thread NPT 1/2"
- Thread M20

Only G1/2 is selectable for TIIS Ex d[ia] and 2 cable glands SXC-16B, are attached.

Caution!

In case of Ex d, please prepare a metal cable gland (not a plastic one) that has shield cable grounding functionality to meet the condition of EMC certification.

Except as noted above, cable gland is not provided with the NMT 539.

Size and condition of the communication cable must meet the requirements of intrinsically safe local HART® communication.

Process connection

Converter only version

NMT 539's local HART® converter can fit onto third party average temperature probes with the following mechanical connection size and type:

- G 3/4" (equivalent to NPS 3/4") universal coupling.... Housing type 1
- M20 threaded.... housing type 2, specific design to fit to Varec 1700 terminal housing



Note!

Use seal tape to secure the connection between converter and temperature probe.

Please refer to the NMT 539 instruction manual for the detailed installation procedure.

Converter + Temp. , Converter + Temp. + WB version

All three versions have the same installation method to fit onto the tank nozzle.

The following flange sizes are available:

- JIS 10K 50A RF, SUS316
- ANSI 150lb 2" RF, SUS316
- JPI 150lb 2" RF, SUS316
- DIN DN50 PN 10RF, SUS316

Installation height adjuster

An additional feature of the NMT 539, the height adjuster, can be used to adjust installation height of the NMT 539 within approximately ± 180 mm (7") from original height.



Note!

The height adjuster is not included in "Converter only" version.



Caution!

Please tighten the lock nut with seal tape to secure rigidity of the NMT 539 at the end of physical installation and/or if the height adjuster will be used during operation. A loose lock nut can lead to improper tank sealing or unexpected leakage into the tank.

WB blocking distance

The Water Bottom sensor can be set as low as zero clearance from the tank floor by using height adjuster. Due to mechanical design of WB sensor, bottom plate has approximately 10mm thickness. This will become a blocking distance (ineffective measuring range).



Caution!

Calculate vertical movement of NMT 539 installation height prior to setting the WB sensor bottom clearance. Typical tank shell deformation causes vertical movement at a minimum 20 ~ 30mm (1"). Excessive weight load of entire NMT 539 on WB sensor by contacting tank floor may cause critical damage that disables accurate & stable WB level measurement.

Recommended installation height

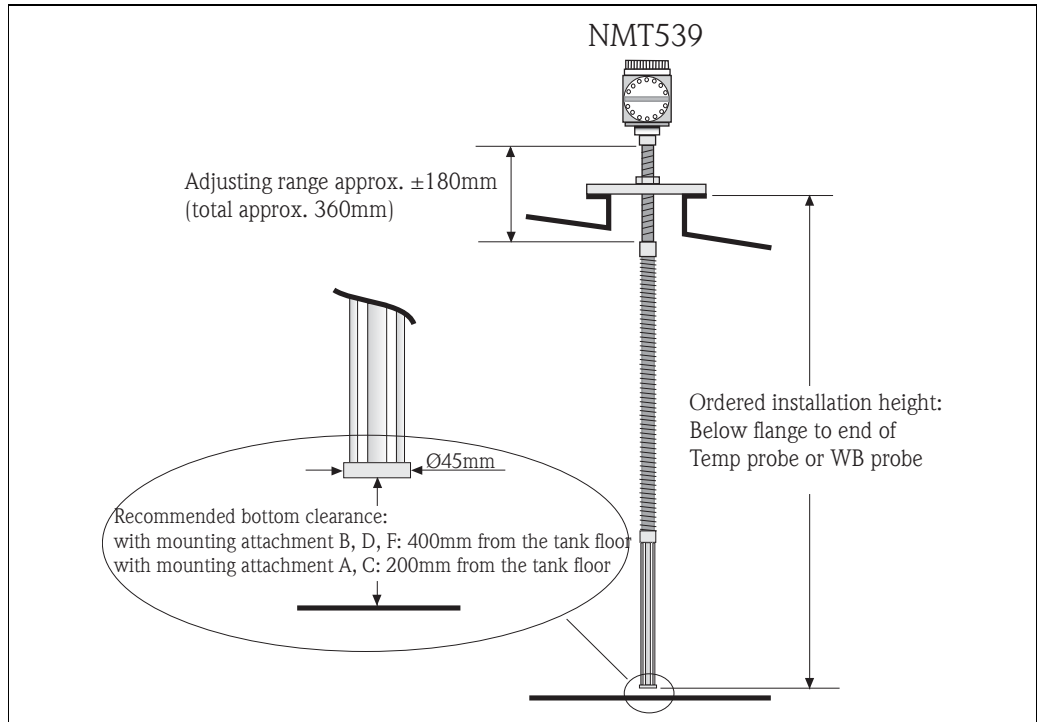

Note!

The required bottom clearance of both the temperature probe and WB sensor depends on the anchoring method. Consider the required bottom clearance when ordering the NMT 539. Please see the recommended bottom clearance in the above illustration and/or consult your Endress+Hauser representative for further information.

When ordering the NMT 539 with special element position and bottom clearance, please refer to "Ordering Information," section 80, Element Spacing. Select 4, Equally spaced, defined by length.

The standard location of the lowest temperature element should be set at 500 mm (20") from the tank bottom regardless of probe type.

Recommended still pipe installation

Note!

Datum plate should be mounted on tank bottom (A) below the slotted still pipe (B) or located at least 300 (11.8 inches) below the slotted still pipe (as shown below drawing).
 If anchor weight is not used with still pipe method, the water bottom should extend out from the end of the still pipe, enough to allow liquid to enter/exit the pipe.
 When using still pipe, it is available from 50A(2") (JIS, ANSI) pipe
 when using anchor weight, use more than 100A(4") (JIS, ANSI) pipe.

Caution!



Do not allow turbulence to carry/shake the water bottom sensor laterally, such movement may damage the sensor.

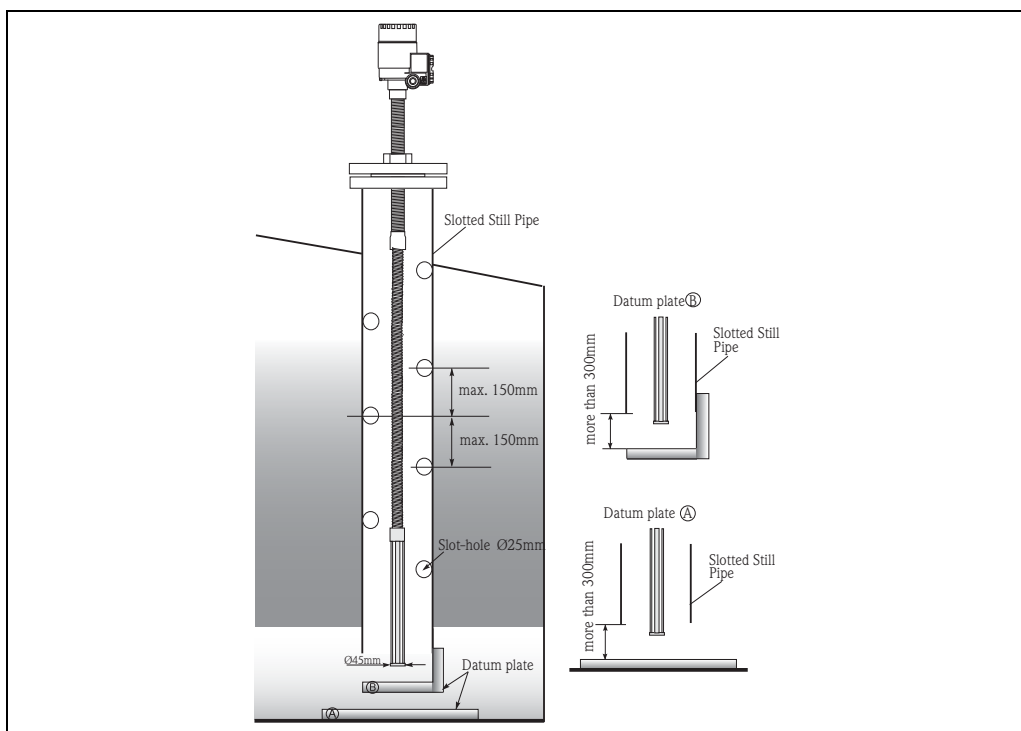

Installation equipment

The bottom anchor hook on the WB sensor is not available when "A: no installation material" is selected. The Converter + Temp. probe version includes the bottom anchor hook as standard, although, "A: no installation material" is selected.

Contents of anchoring hardware: Based on the choice of "100: Mounting attachment"

	A: No installation Material	B: Anchor weight (High profile, D120)	C: Anchor weight (Low profile, hexagon H41)	D: Tension wire + wire hook + NPT1 top anchor	F: Tension wire + wire hook + R1 top anchor
0: Converter only	none	none	none	none	none
1: Temp. + Converter	bottom hook	bottom hook anchor weight sling wire	bottom hook anchor weight sling wire	bottom hook base plate wire hook NPT1 top anchor tension wire	bottom hook base plate wire hook R1 top anchor tension wire
3: Temp. + WB + Converter	none	same as above	same as above	same as above	same as above

Mounting attachment B : "High profile anchor, D120" , D : "Tension wire + Wire hook +NPT1 Top anchor" or "F : "Tension wire + Wire hook + R1 Top anchor"

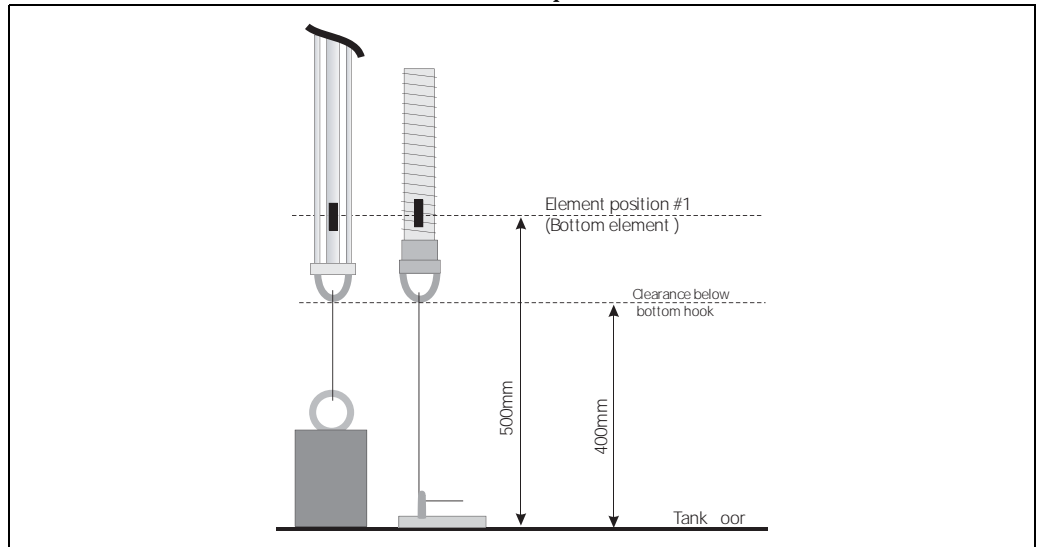

"High profile anchor weight" is the anchor method designed for converter + temperature probe. Both temperature probe and WB sensor with "High profile anchor weight" and "Tension wire anchor" methods have a recommended clearance below the bottom of the anchor hook of approximately 400 mm (16"). This clearance can be easily changed by turning the height adjuster at the tank top.



Note!

When ordering the NMT 539, please refer to "Ordering Information," section 80, Element Spacing. Select 4, Equally spaced, defined by length. This allows you to choose the desired element position and intervals.

Mounting attachment A : "No installation material" and C : "Low profile anchor, hexagon H41"

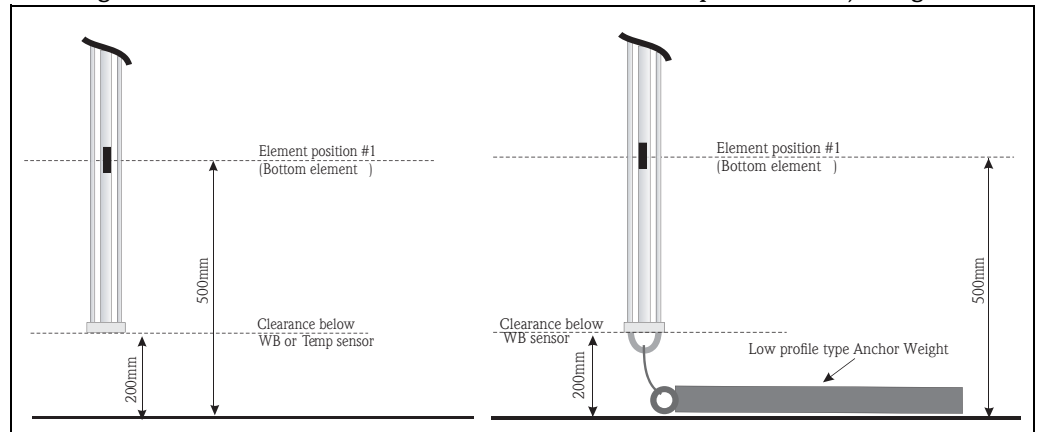

"Low profile anchor weight" is provided to anchor WB probe and to measure accurately water bottom range. When installing NMT539 on small tank nozzle [max.50A (2")] in operating tank, it is available as mounting attachment for converter + temperature probe version. Both the temperature probe and WB sensor with "Low profile anchor weight" at 100: Mounting attachment option (see Ordering Information) should have 200 mm (8") of bottom clearance from the edge of probes.



Note!

The lowest possible WB measuring point can be approx. 10 mm from the tank floor with "No installation material" selected (see Ordering Information). If necessary, use the height adjuster to set at the desired installation height. No bottom anchor hook is available with the WB sensor and 100: Mounting attachment "A : No installation material".

Prothermo NMT539 #1 Element position

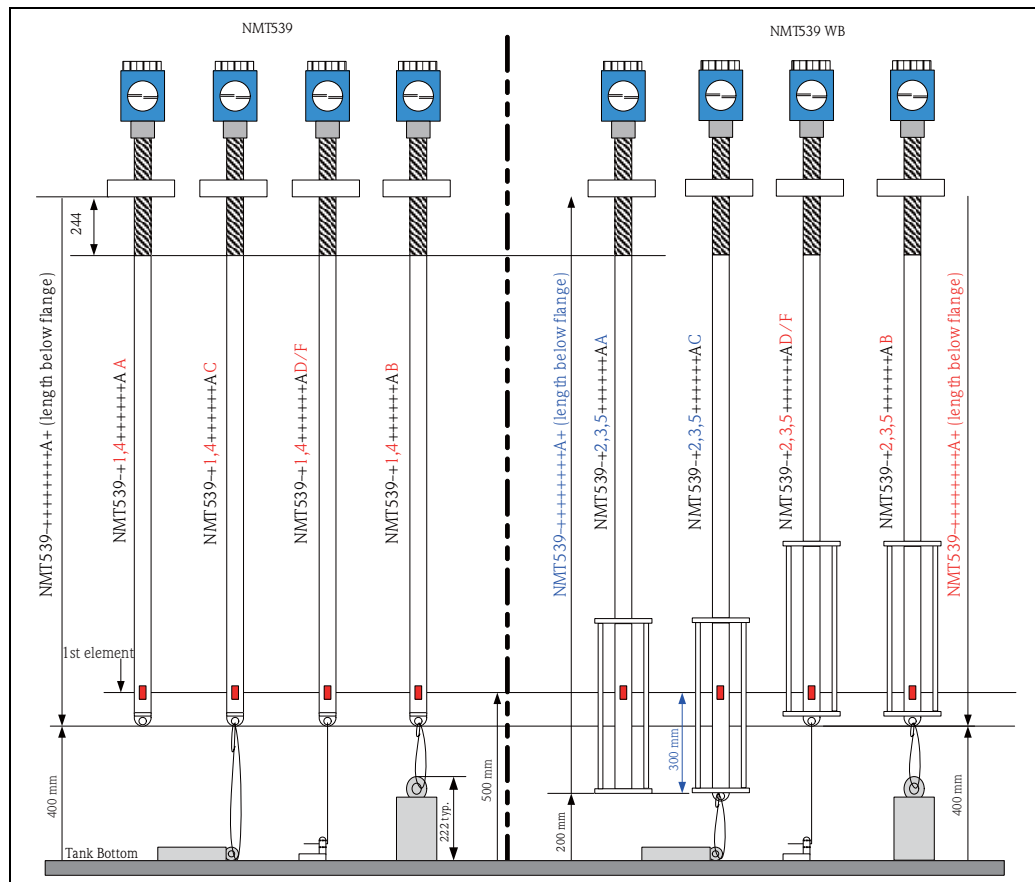

Mounting and element position of Prothermo NMT539 anchor weight method

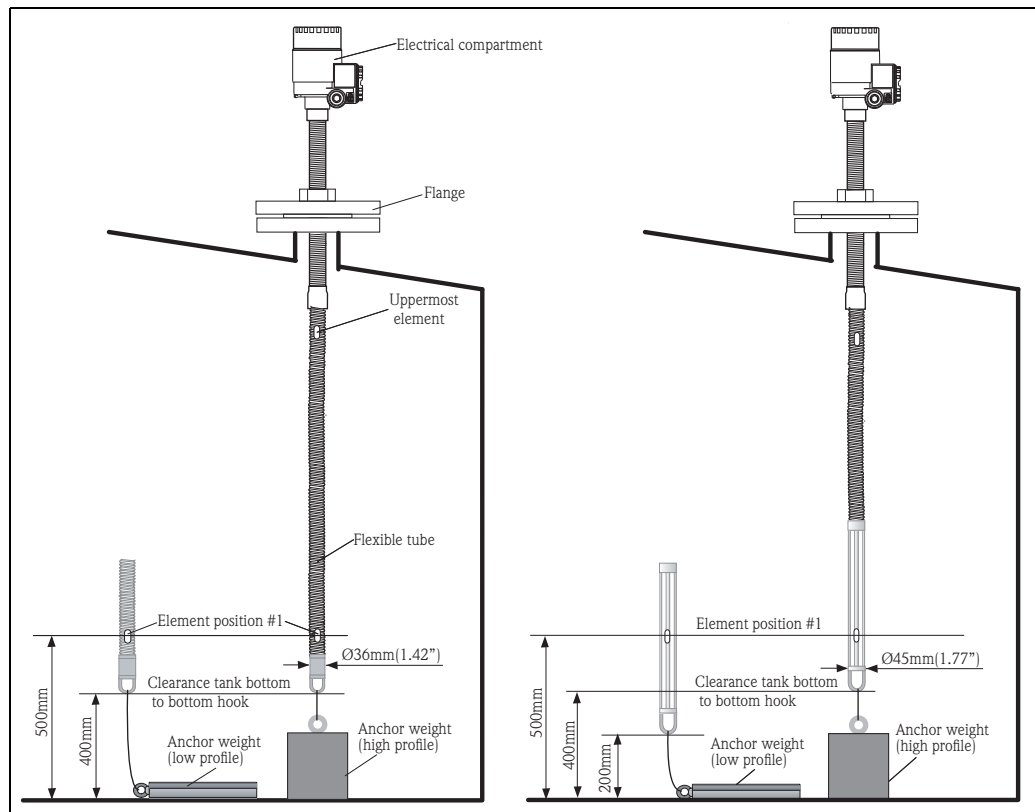

Operating condition : wiring

TIIS Ex d[ia] wiring

When the Prothermo NMT539 TIIS, Ex d [ia] available only in Japan, Class A grounding directly from NMT539 is required.



Note!

The grounding cable for safety barrier in Prothermo NMT539 should be connected independent of any other devices or purpose, according to “Class A grounding” standards.
 Use a conductive grounding wire with cross-sectional dimensions 2~2.6mm².
 In an instrumentation room, a field device with Class A ground may be connected in common with the communication cable shield.

"Class A ground" general description

Ground resistance value	10 Ω or less
Grounding cable	Tensile strength : more 1.04kN Metallic wire Cross-sectional dimensions : more than 2~2.6mm ² copper wire Cable finished external diameter : more than Ø8mm

Example of Grounding cable construction (TIIS Ex d[ia])

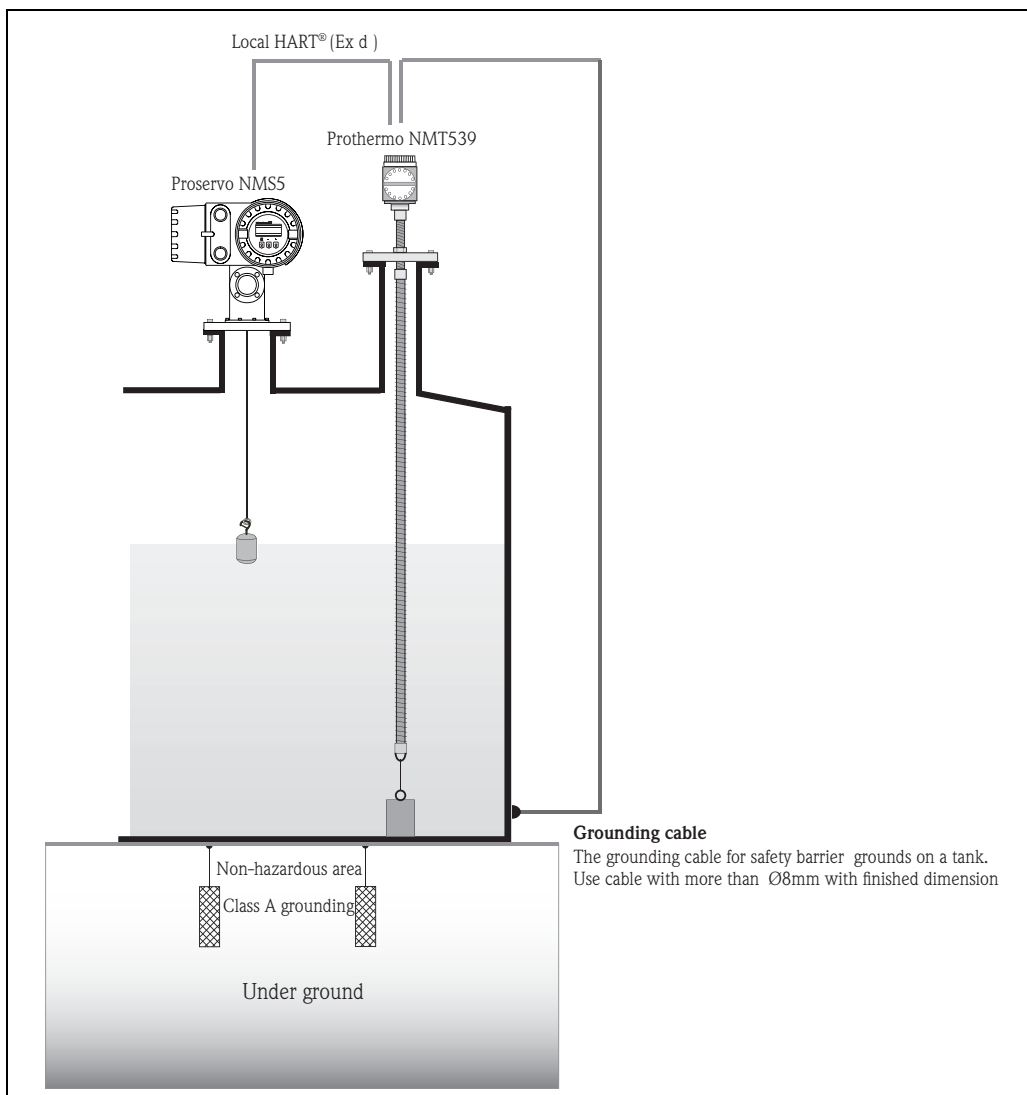

**Connecting diagram
(TIIS Ex d[ia])**

Note!

Install wiring in a manner to prevent current or voltage from causing electro magnetic interference on the i.s. circuit.

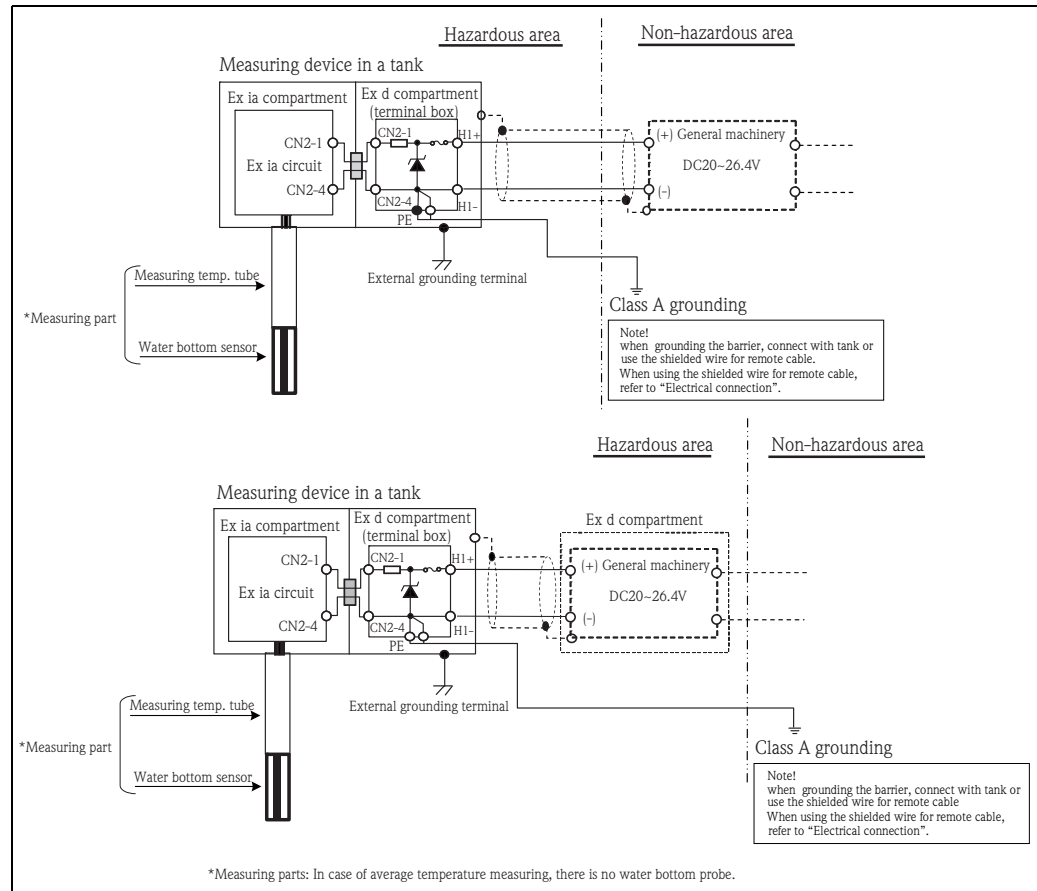

Operating condition: terminal connection

Ex ia
NMT539 terminal



Note!

The NMT539 (Ex ia) allows an intrinsically safe local HART® connection. Please refer to the i.s. regulation for establishing wiring and field device layout.

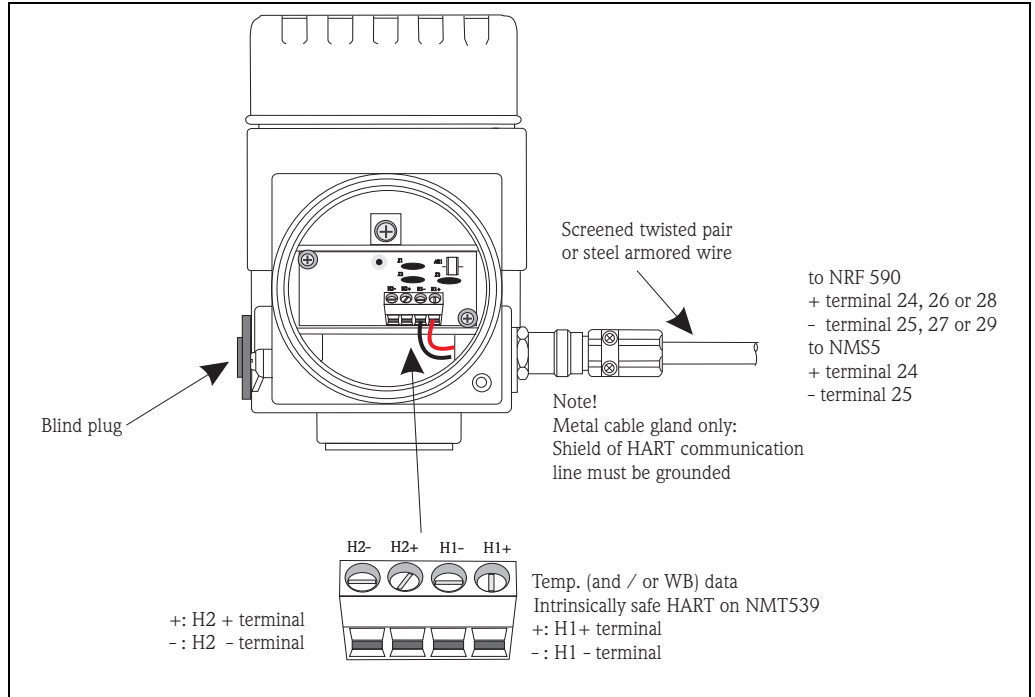

ATEX, FM, CSA ... Ex d[ia]
Proservo NMS5 terminal

Since the Prothermo NMT539 is an intrinsically safe instrument, the terminal connection to the Ex i side on local HART® connection is allowed on the NMS5 terminal housing.

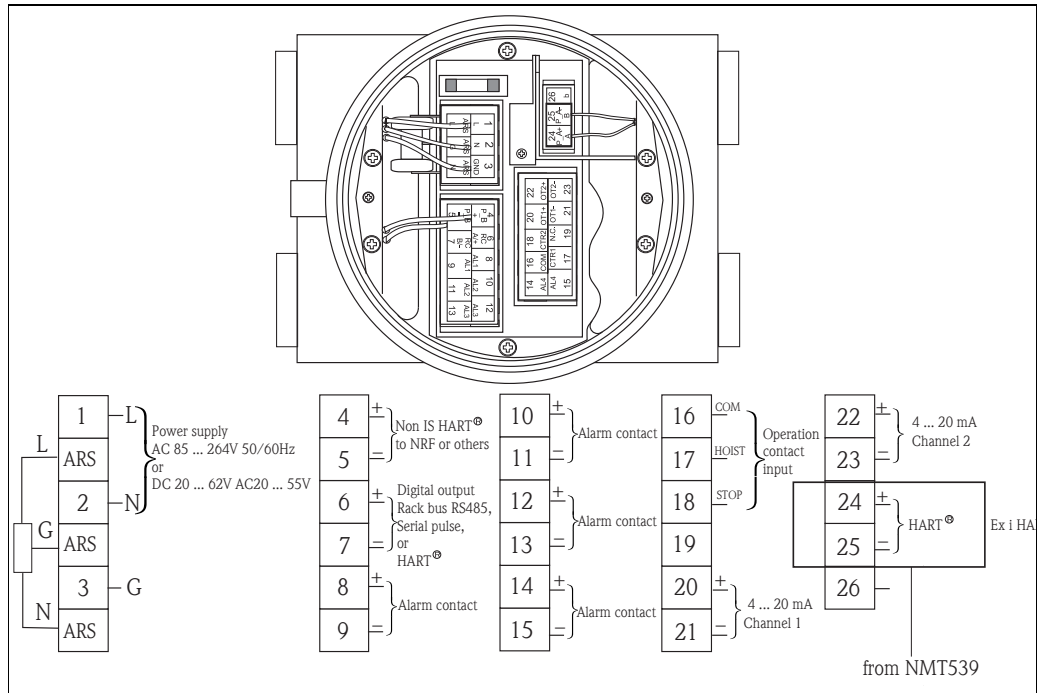

Note!



Do not connect the NMT539 local HART® communication on terminals 4 and 5 on the Proservo NMS5. These terminals are designed to connect Ex d local HART® communication.

**TIIS Ex d[ia]
Prothermo NMT539
terminal**



Note!

The NMT539 Ex d[ia] allows a local HART® connection available in Japan. Please refer to the i.s. regulation for establishing wiring and field device layout. local HART® multi drop connection depends on approval type.

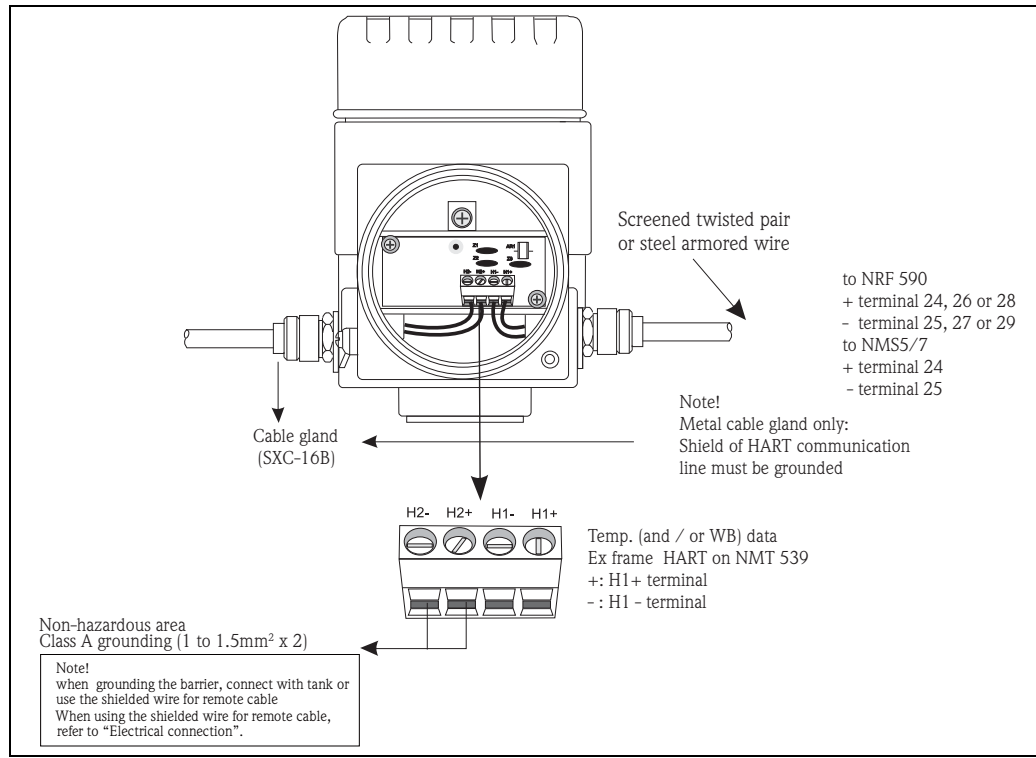

**Ex d
NMS5 connection**

Connect Prothermo NMT539 Ex d[ia] to Proservo Ex d terminals.

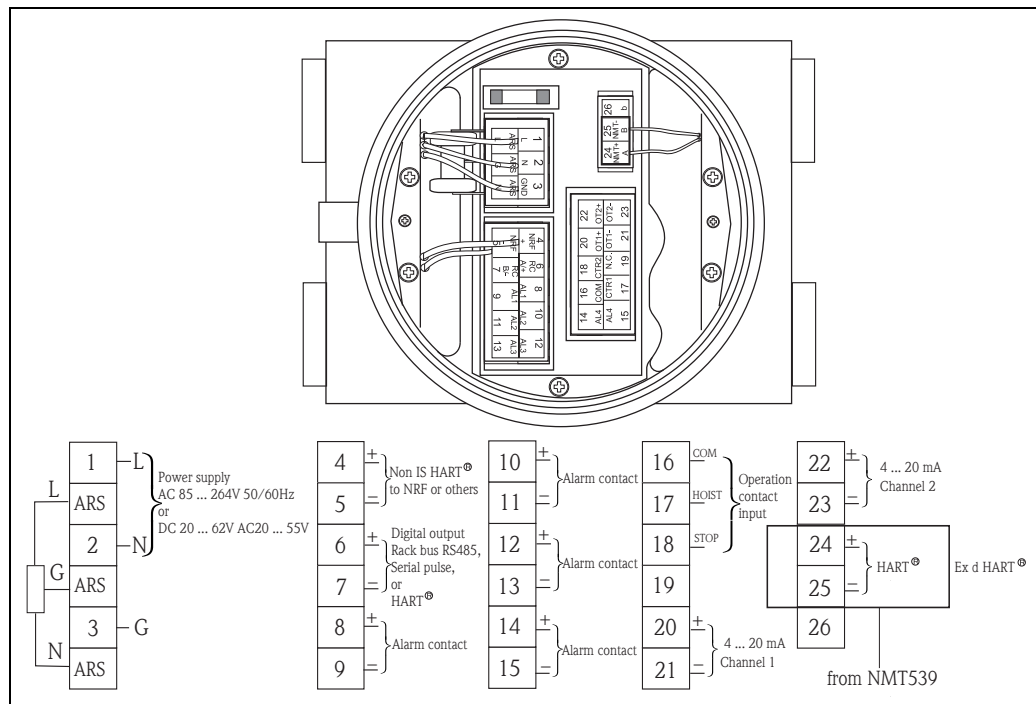

TGM5/TMD1 terminal

When TGM5 except Sakura code (collector common), BCD (emitter common), BCD (collector common) is equipped with local HART® communication, it is possible to connect Ex d[ia] equipment, but terminal number depends on the specification. Please see terminal figure for TGM5.
 In case of TMD1-xBxxxxxxxxx (with local HART® input), it is possible to connect Ex d[ia] equipment, but terminal number depends on the specification. Please see terminal figure for TMD1.

Terminal connection on the Tank Side Monitor NRF590

Ex ia terminal

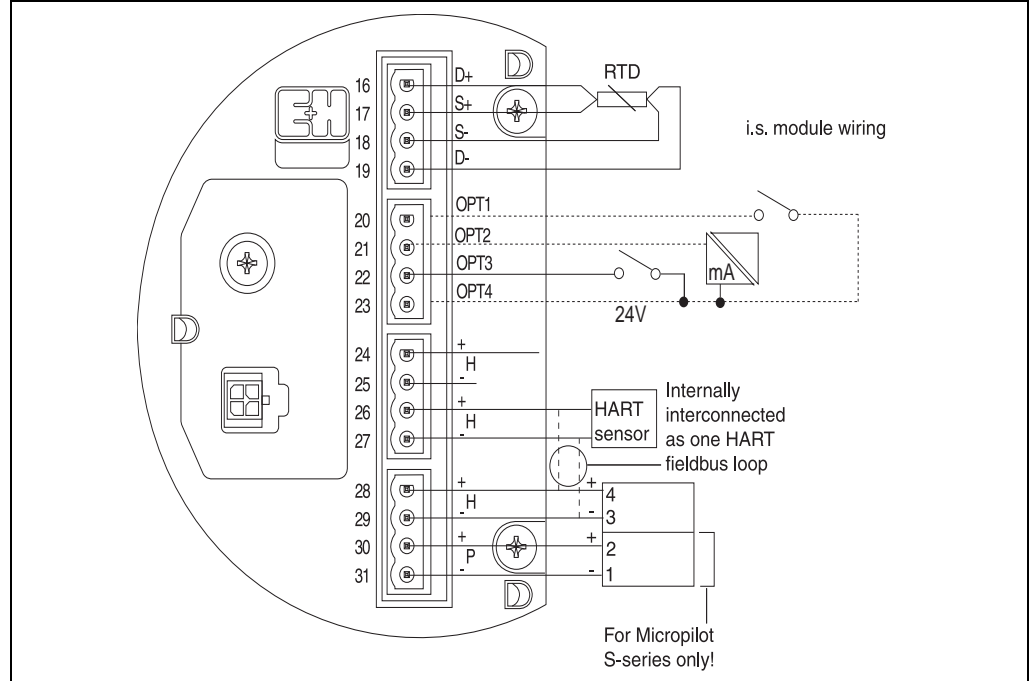

Note!



The Tank Side Monitor NRF590 has three sets of i.s. local HART® terminals.

Caution!



Do not connect signal local HART® lines from the NMT539 to terminals 30 and 31. They are designed to supply drive power for the FMR 53x series only.

TIIS Ex d terminal

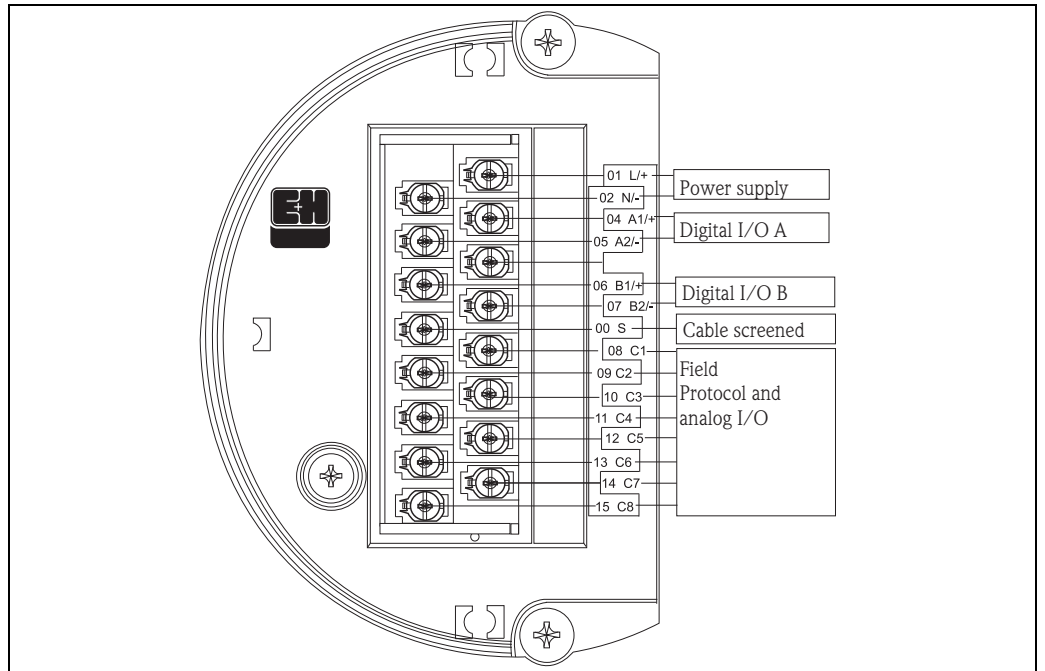

Operating condition : Environment

Ambient temperature range	-40 C° ... +85C°(-40°F...+185°F) -20 C° ... +60C°(-4°F...+140°F)...TIIS
Storage temperature	-40 C° ... +85C°(-40°F...+185°F)
Climate class	DIN EN 60068-2-38 (test Z/AD)
Degree of protection	Housing : IP65, (Converter only, open housing: IP20) Probe : IP68
Electromagnetic compatibility	When installing the probes in metal and concrete tanks and when using a coax probe: <ul style="list-style-type: none"> ■ Interference Emission to EN 61326, Electrical Equipment Class B ■ Interference Immunity to EN 61326, Annex A (Industrial)

Operating condition : Process

Process temperature range	Temperature probe : -170 ...+235 °C (-274 ...+455°F) WB probe : 0 ...+100 °C (+32 ...+212°F)
Process pressure limits	100kPa
Data transmission	2.5mm coaxial cable & common ground

Mechanical construction

Type 1: Converter only version

Standard PF(NPS) 3/4" universal coupling connection

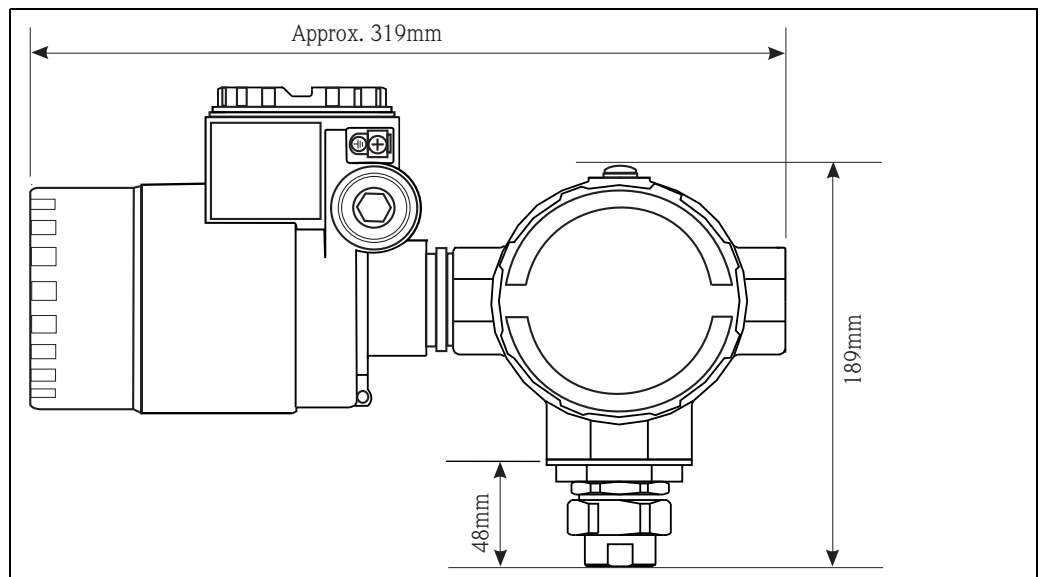

Type 1: Measuring function

The Converter only version is the direct replacement of the previous NMT 538 series. Connection and compatibility are provided to third party temperature probes with various element types. Unlike the NMT 538, the powerful processor of the NMT 539 calculates and converts the following element types without altering the program (EPROM installed software):

- Pt100
- Cu100
- Cu90
- PtCu100

The type 1 converter also enables connection to a dual function average temperature and capacitance WB probe, such as the Weed Beacon MWR. Wiring, however, requires the isolation of the RTD temperature signal from the capacitance WB signal on coaxial cable. The wiring of the temperature signal is exactly the same as Endress+Hauser's 1700, 9909 and other RTD probes. The coaxial (WB) cable must be routed from the existing auxiliary capacitance to the local HART® (or 4 - 20 mA) converter via NMT 539's terminal compartment.



Caution!

NMT 539 is only compatible with MRTs (Multi-Resistance Thermometers) and/or MSTs (Multi-Spot Thermometers). It is not designed to work with "Thermocouple" type thermometers.

The physical connection between probe to NMT 539 is completed by Zinc plated carbon steel PF 3/4" (NPS 3/4") universal threaded coupling. In case a different thread size is required, Endress+Hauser can provide the simplest and most efficient solution by adapting a variety of coupling sizes and materials based on existing temperature probe specifications.

The power supply and data transmission lines are both fed to the host gauge, Proservo NMS5 or Tank Side Monitor NRF 590, by one pair of local HART® loop connections. In addition to the user-friendly display, the NMT 539 can also be configured and operated via the ToF (Time-of-Flight) tool or FieldCare.

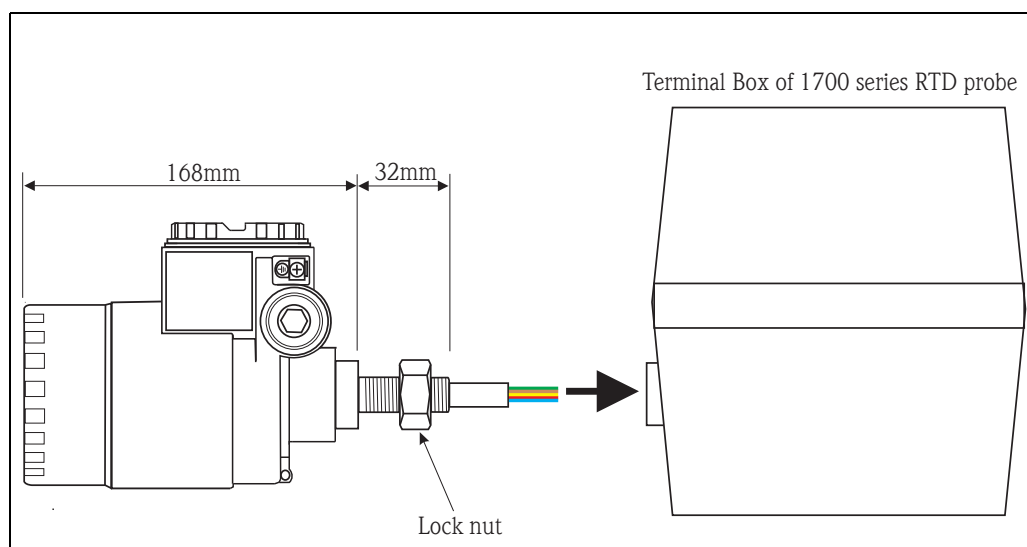
**Type 2: Converter only
version****For the Varec 1700, M20 threaded connection****Type 2: Measuring function**

Basic functionality remains the same, but the special M20 threaded connection allows the NMT 539 converter to fit directly onto the existing terminal housing of the 1700.

Actual wiring of the RTD signal from the probe to the NMT 539 must be executed in the terminal box of the 1700, not the NMT 539. Therefore, the type 2 converter only has a primary housing that contains NMT 539 electronics and no secondary housing is included.

**Caution!**

Secure the threaded connection with seal tape and tighten the lock nut at the actual installation. A loose connection of the NMT 539 & Varec 1700 terminal housing can cause serious electrical damage depending on environmental conditions.

Converter + average temperature probe version

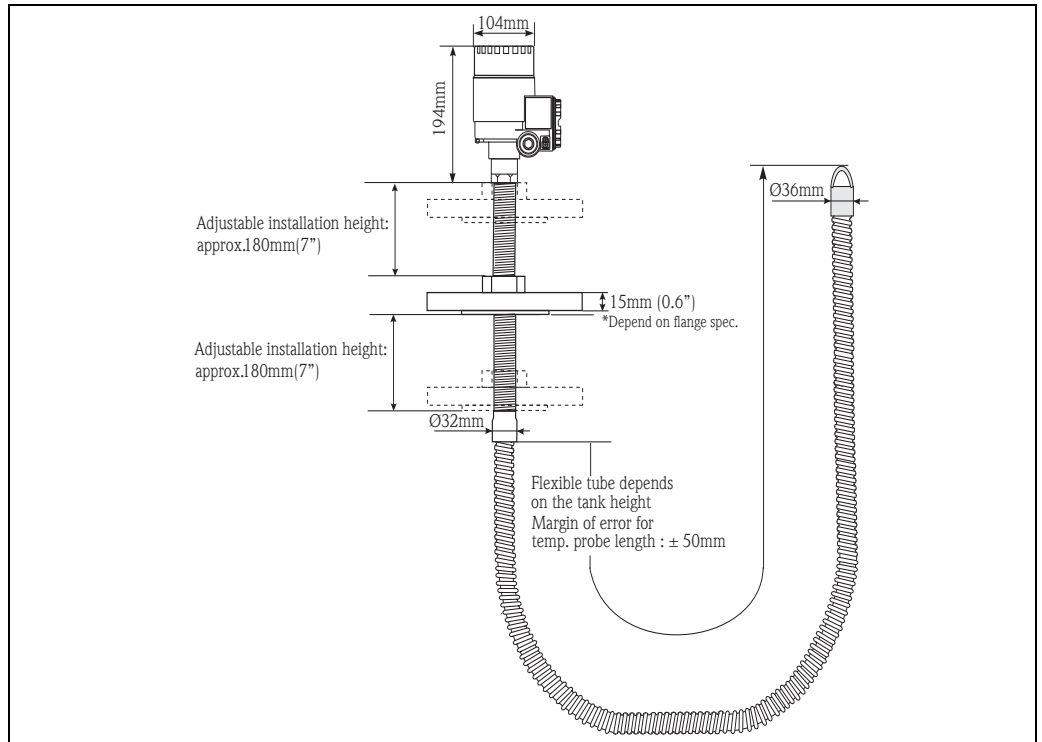

Measuring function

The W&M approved high accuracy temperature device is well suited for both custody transfer and inventory control applications. Based on the product temperature range and specific application, the NMT 539 has several different temperature ranges to meet your application requirements:

Temp. range	Approval	Application
-20 ...+100°C (-4 ...+212 °F)	TIIS	Most standard temperature range for inventory control applications
-20 ...+235°C (-4 ...+455 °F)	TIIS	Capability of high and / or low temperature product applications like sulfur & asphalt and moderate liquid / gas application.
-40...+100°C (-40 ...+212 °F)	ATEX/FM/CSA/ IECEX	Most standard temperature range for inventory control applications
-55...+235°C (-67 ...+455 °F)	ATEX/FM /CSA/ IECEX	Capability of high and / or low temperature product applications like sulfur & asphalt and moderate liquid / gas application
-170 ...+60°C (-274 ...140 °F)	TIIS	Cryogenic, e.g. LNG, ethylene...
-20 ...+120°C (-4 ...248 °F)	PTB	[PTB (Germany)] : W&M certified applications.

The NMT 539 converter and average temperature probe consists of up to 16 IEC class A Pt100 elements in the protection tube. The very sensitive sensor elements change resistance values depending on the surrounding temperature. Therefore, applied voltage through this sensor deviates based on resistance change at the element. As a specific design to meet intrinsically safe standards, the NMT 539 converter and temperature version is built with a very efficient power management concept.

In order to achieve the highest degree of measurement accuracy and mechanical & electrical durability, NMT539 employs a powerful processor, large storage capacity, and simple module structure.

To achieve the user-friendly concept, the newly adopted height adjuster allows the adjustment of the installation height up to approximately 360mm (14") at the process connection (flange) depending on the tank shape and condition.

W&M function

The NMT 539 converter and temperature probe is custody transfer approved. Once the NMT 539 is configured to "W&M mode", all the changeable parameters are frozen by software and mechanical switch protection.

Converter + average temperature probe + WB probe version

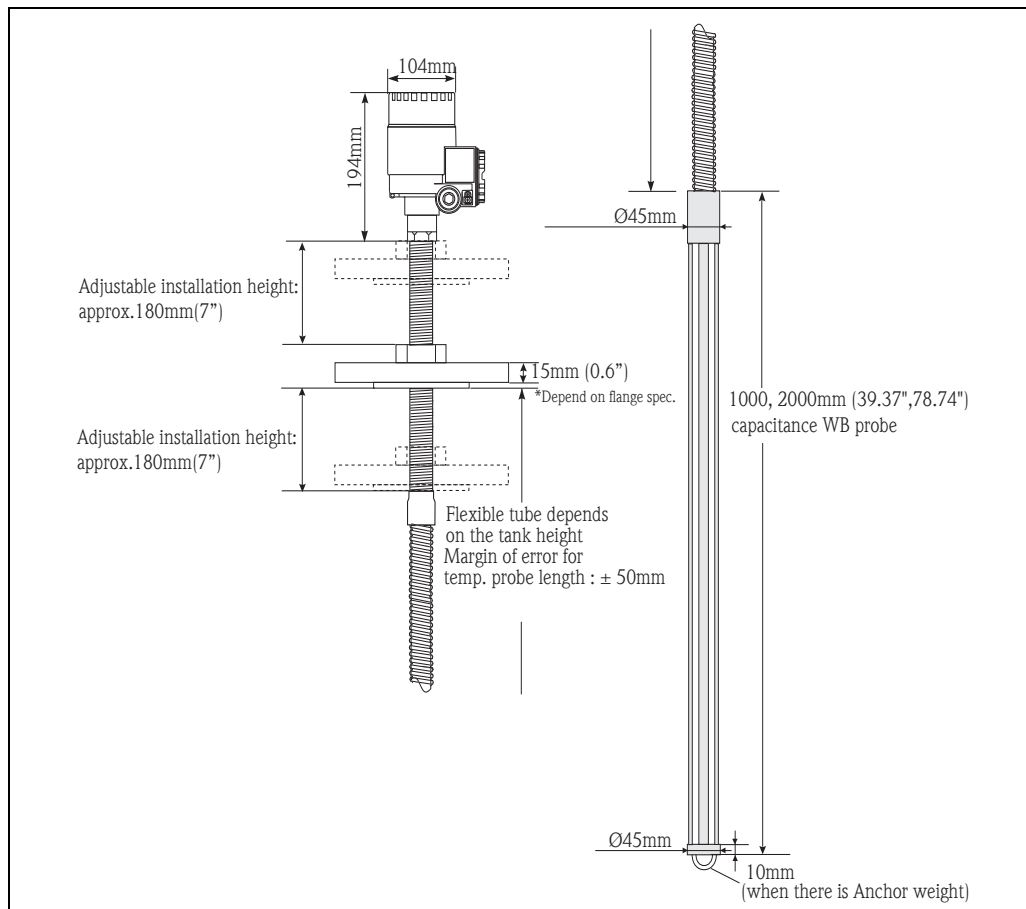

Measuring function

The Prothermo NMT 539 is available in the ultimate all-in-one "Converter + Temp. + WB" version. Both temperature and WB data are fully accessible on one pair of local HART® communication lines. Parameters can be configured via Proservo NMS5/NMS7, Tank Side Monitor NRF 590, ToF tool, FieldCare.

The integrated WB sensor (capacitance water interface measurement) is set at the bottom of the average temperature probe. The standard WB measurement ranges are 1m (3.3 ft) and 2m (6.6 ft). The tube structured WB sensor is made of SUS304 pipe and exterior is protected by an additional 1mm thick PFA tube. Pt 100 elements are set inside of this tube structure, meaning that temperature measurement is not disturbed due to the WB functionality.



Caution!

Due to the characteristic of capacitance measurement, precise initial calibration must be performed in order to achieve the maximum measurement accuracy. The condition of tank contents (both oil & water), liquid temperature and individual probe characteristic can greatly effect the measurement performance. Specific accuracy & repeatability measurement must be taken within the same environment in order to perform data comparison.



Note!

If water in the tank freezes, it is not possible to measure the water interface. Protect the water in the tank from freezing.

WB probe design

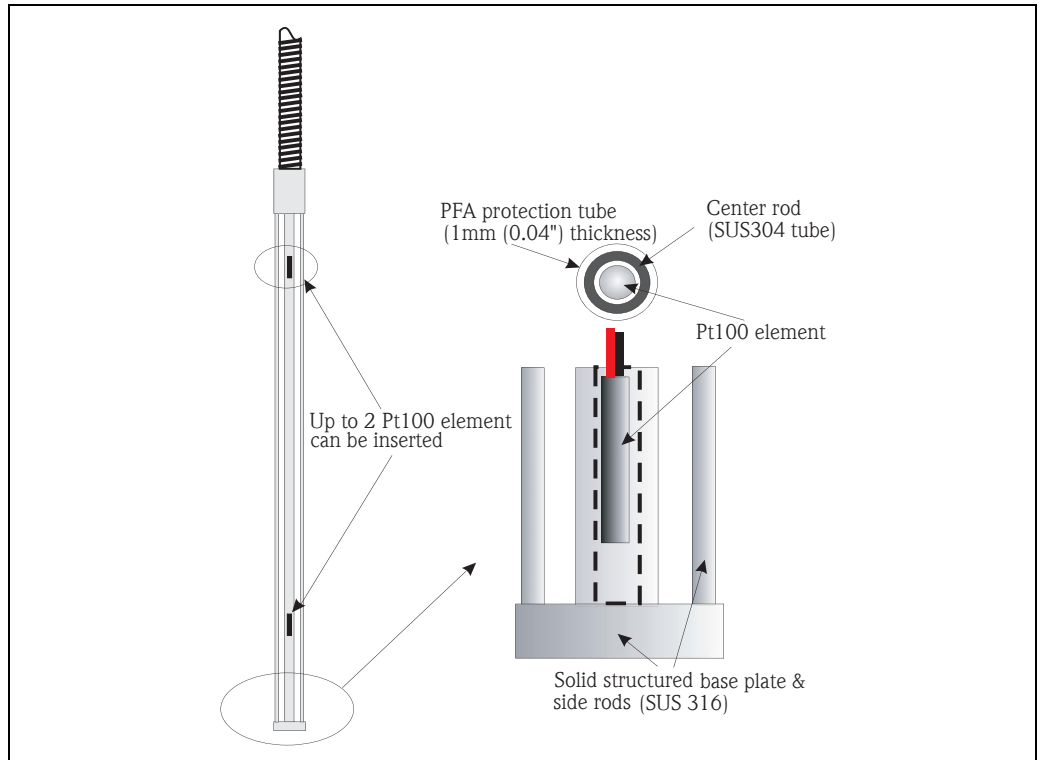

Weight Approx. 13kg
 Condition:
 16 elements
 Temp. probe : 10m
 WB probe: 1m
 Flange : 2" 150lbs RF, SUS316

Material Elements : Class A Pt100, IEC PUB 751 1995, JIS 1604 1997
 Housing : Aluminum diecast
 Temp. probe : SUS316 flexible tube
 WB sensor : SUS316 (center rod SUS 304 & PFA protected)

Human interface

Operation using ToF Tool, FieldCare

The Prothermo NMT539 can also be operated via the ToF Tool or FieldCare Package. These programs support commissioning, securing of data, signal analysis and documentation of the instruments. They are compatible with the following operating systems: WinNT4.0, Win 2000 and Win XP.

The ToF Tool and FieldCare Packages support the following functions:

- Online configuration of transmitters
- Loading and saving of instrument data (Upload/Download)
- Documentation of measuring points

Certificates and approvals

CE approvals

By attaching the CE mark, Endress+Hauser confirms that the instruments pass the required tests.

Ex approvals

Ex approval	Class
ATEX	II 1/2 G Ex ia IIB T2...T6
IECEX	Ex ia IIB T2 - T6 Ga/Gb
FM	IS Class 1, Div. 1, Gp. C, D, T6, T4, T3, T2 Class 1, Zone 0, AEx ia IIB, T6, T4, T3, T2
CSA	Ex ia Class 1, Div.1, Gp. C, D, T6...T2 Ex ia IIB T6...T2
TIIS	Ex ia IIB T4
	Ex ia IIB T2
	Ex d[ia] IIB T4

PTB W&M approval

PTB 14.70 08.01 (Germany)

External standards and guidelines

IEC 61326 Appendix :A, Immunity according to table A-1

EN 60529

Protection class of housing (IP-code)

EN 61326

Emissions (equipment class B), compatibility (appendix A - industrial area) EN61000-4-2
Immunity to electrostatic discharge

IEC 61508

Functional safety of electrical/electronic/programmable electronic safety-related systems

Ordering information

010	Protection class:			
	0	Weather proof, IP65 NEMA4X		
	7	FM IS Cl.I Div.1 Gr.C-D		
	8	CSA IS Cl.I Div.1 Gr.C-D		
	B	ATEX Ex (ia) IIB T2-T6		
	C	TIIS Ex ia IIB T2		
	A	TIIS Ex ia IIB T4		
	E	TIIS Ex d (ia) IIB T4		
	F	IEC Ex ia IIB T2-T6 Ga		
	9	Special version, TSP-no. to be spec.		
020	Measuring function:			
	0	Converter		
	1	Temperature, Converter		
	3	Temperature, Water Bottom, Converter		
	4	Temperature, Converter (PTB type approval)		
	5	Temperature, Converter, Water Bottom (PTB type approval)		
	9	Special version, TSP-no. to be spec.		
030	Temperature Measuring Range:			
	0	Not selected		
	5	-20 ...+100 °C		
	1	-40 ...+100 °C		
	6	-20 ...+235 °C		
	2	-55 ...+235 °C		
	3	-170 ...+60 °C		
	4	-20 ...+120 °C (PTB type approval only)		
	9	Special version, TSP-no. to be spec.		
040	Water Bottom Measuring range:			
	0	Not selected		
	1	1m/3.3 ft.		
	2	2m/6.6 ft.		
	9	Special version, TSP-no. to be spec.		
050	Cable entry:			
	A	Thread G1/2		
	B	Thread NPT1/2		
	D	Thread M20		
	9	Special version, TSP-no. to be spec.		
060	Process connection :			
	0	10K 50A RF, SUS316, flange JIS B2220		
	1	2" 150lbs RF, SUS316, flange ANSI B16.5		
	2	DN50 PN10 B1, SUS316, flange EN1092-1 (DIN2527 B)		
	3	50A 150lbs RF, SUS316, flange JPI 7S-15		
	4	Universal coupling, G3/4, (converter only)		
	5	Thread M20 (converter only)		
	9	Special version, TSP-no. to be spec.		
NMT539-				Product designation (part1)

070																				Temperature Element:				
																				A	2 x Pt100			
																				B	3 x Pt100			
																				C	4 x Pt100			
																				D	5 x Pt100			
																				E	6 x Pt100			
																				F	7 x Pt100			
																				G	8 x Pt100			
																				H	9 x Pt100			
																				J	10 x Pt100			
																				K	11 x Pt100			
																				L	12 x Pt100			
																				M	13 x Pt100			
																				N	14 x Pt100			
																				O	15 x Pt100			
																				P	16 x Pt100			
																				Q	Not selected			
																				Y	Special version, TSP-no. to be spec.			
080																					Temperature Element Spacing:			
																					7	UK standard (converter only)		
																					3	1m / 39"		
																					2	1.5m / 59"		
																					1	2m / 79"		
																					5	3m / 118"		
																					4	Equally spaced, defined by length		
																					6	Not selected		
																					9	Special version, TSP-no. to be spec.		
090																						Probe Length:		
																						Amm	
																						B	Not selected	
																						C , Gas-tight feed through	
																						Y	Special version, TSP-no. to be spec.	
100																							Mounting Attachment:	
																							A	Not selected
																							B	Anchor weight, high profile (D120)
																							C	Anchor weight, low profile (hexagon H41)
																							D	Tension wire, wire hook, NPT1 top anchor
																							F	Tension wire, wire hook, R1 top anchor
																							G	*Bottom hook
																							Y	Special version, TSP-no. to be spec.
NMT539-																								Complete product designation

Note!

030 Temperature Measuring Range:

5 : -20...+100°C (TIIS only)

6 : -20...+235°C (TIIS only)

090 Probe Length:

A :mm (TIIS : 1000 ≤ L ≤ 30000)

C : , Gas-tight feed through (TIIS : 1000 ≤ L ≤ 40000)

Y :mm (TIIS : 30000 < L ≤ 40000)

Accessories

Anchor weight (high profile, D120) mounting attachment option: B



This high profile anchor type is designed for Converter + temperature probe versions.

Caution!

Installation of the anchor weight will cause the lowest temperature measurement position to be raised approximately 400mm (16") from the tank floor.

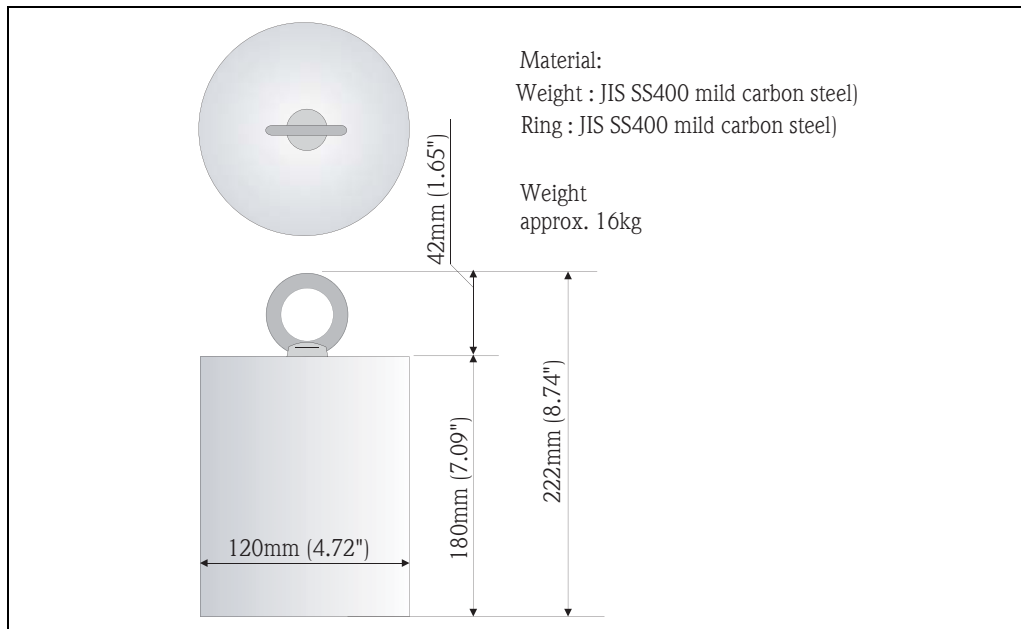

Different dimensions, weight and material for the anchor weight are also available.

Anchor weight (low profile, hexagon H41) mounting attachment option: C

The low profile anchor weight is mainly designed to stabilize the WB sensor, securing it straight up without shortening the WB measuring range. It is also suitable for an existing tank installation with a small nozzle opening for converter and temperature version.

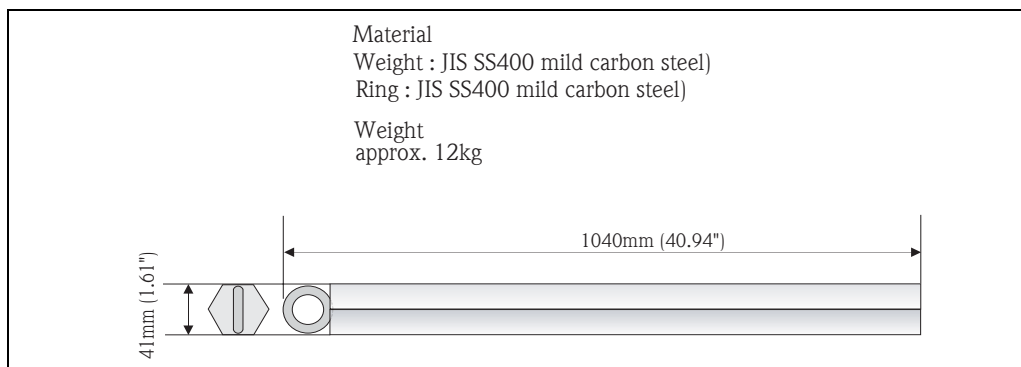

**Wire hook, Top anchor
mounting attachment
option: D,F**

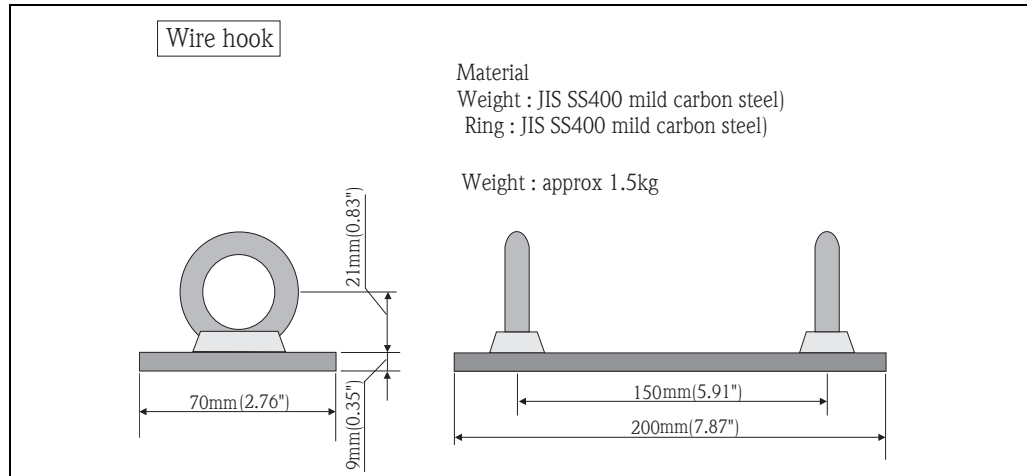

Actual tensioning can be completed with SUS316 stranded 3mm diameter tension wire between wire hook and top anchor.

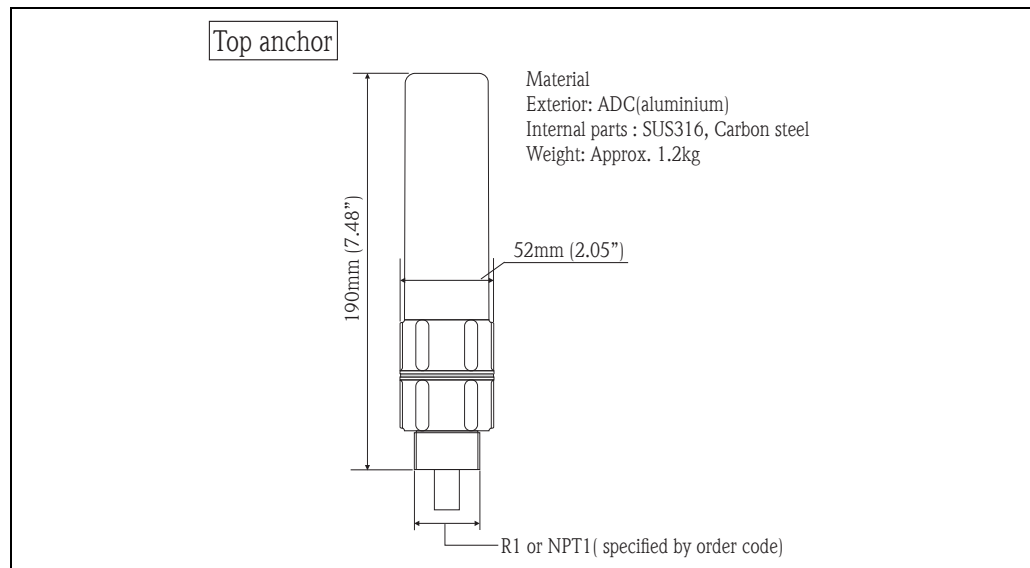

Note!
 The standard process connection of the top anchor is R1 or NPT1 threaded connection.

Documentation

Technical Information

TI00452G
Proservo NMS5

TI008N
Promonitor NRF560

TI024N
Digital Transmitter TMD1

Operating Instructions

BA01025G
Prothermo NMT539 (Installation Instructions)

BA01026G
Prothermo NMT539 (Operating Instructions and Description of Instrument Function)

Certificates

Prothermo NMT539	TIIS	ATEX	IEC	FM	CSA
Temp. converter	Ex496-826XJ (Ex ia)	XA00585G-A	XA00583G-A	Ex461-851-1	Ex462-712-2
Average temp.and/or WB sensor	Ex463-820XJ (Ex ia)			Ex461-850-1	Ex462-711-2
Average temp. (high temp.)	Ex495-823XJ (Ex ia)				
Average temp. (low temp.)	Ex1061-986XJ (Ex ia)				
Average temp.and/or WB sensor	Ex1016-983XJ (Ex d[ia])				

Appendix

Stainless Steel conversion table

The stainless steel material used in products of Endress + Hauser Yamanashi normally have expressions according to Japanese industrial standards, such as JIS. Each country or region may have different expressions. The following conversion table contains the expression of equivalent stainless steel material based on chemical composition and mechanical properties.

Country	Standard	Expressions			
		SUS304	SUS304L	SUS316	SUS316L
Japan	JIS				
Germany	DIN 17006	X5 CrNi 18 10 X5 CrNi 18 12	X2 CrNi 18 11	X5 CrNiMo 17 12 2 / 1713 3	X2 CrNiMo 17 13 2
	W.N. 17007	1.4301 1.4303	1.4306	1.4401 / 1.4436	1.4404
France	AFNOR	Z 6 CN 18-09	Z 2CN 18-10	Z 6 CND 17-11 / 17 12	Z2 CND 17-12
Italy	UNI	X5 CrNi 1810	X2 CrNi 1911	X5 CrNiMo 1712 / 1713	X2 CrNiMo 1712
U.K.	BSI	304S15 / 304S16	304S11	316S31 / 316S33	316S11
U.S.A.	AISI	304	304 L	316	316L
U.E.	EURONORM	X6 CrNi 1810	X3 CrNi 1810	X6 CrNiMo 17 12.2 / 17 13 3	X3 CrNiMo 17 12.2
Spain	UNE	X6 CrNi 19-10	X2 CrNi 19-10	X6 CrNiMo 17-12-03	X2 CrNiMo 17-12-03
Russia	GOST	08KH18N10 06KH18N11	03KH18N11	-	03KH17N14M2
-	ISO	11	10	20	19
-	ASME	S30400	S30403	S31600	S31603

Note!

Standards may be not necessarily correspond exactly to the Japanese Industrial Standard, because they are defined by mechanical and chemical criteria.

Endress + Hauser Yamanashi Co., Ltd.
862-1 Mitsukunugi Sakaigawa-cho
Fuefuki-shi Yamanashi,
406-0846 Japan

Phone: ++81 55 266 4964
Fax: ++81 55 266 4969
<http://www.endress.com>

Endress+Hauser 
People for Process Automation