

Technical Information

Proservo NMS80

Tank Gauging



Application

Proservo NMS8x Series intelligent tank gauges are designed for high accuracy liquid level measurement in storage and process applications. They fulfill the exacting demands of tank inventory management, inventory control, custody transfer, loss control, total cost saving, and safe operation.

Typical areas of application

- Precise level, interface, and density measurement of oil (fuels), petrochemical, chemical, and alcohol
- Tank mounted intelligence makes NMS8x ideal for single or multi-task installation, covering a wide range of measurement functions including Liquid level, Interface level, Spot density, Density profile, Tank bottom, and Water dip and integrating a wide range of tank sensor measurement functions including Water level, Temperature, and Pressure.

Your benefits

- SIL2 certified (Min, Max, Continuous level)
- SIL3 (in preparation)
- Measures liquid level to an accuracy of +/- 0.4 mm (0.016 in)
- Measurement of up to two interface levels and density of up to three liquid phases
- Liquid density profiling of up to 50 points throughout the tank or upper layer, configurable.
- Wetted parts are completely separated from the electronic circuit
- Tank top mounting with 3" flange
- Wide range of output signals including V1, Modbus RS 485, and HART protocol
- Material and pressure rating of the wetted parts can be selected.
- Suitable for atmospheric and high pressure applications up to 6 bar/600 kPa/ 87 psi
- Integration of e.g. temperature, water level, pressure, overfill prevention sensor
- Direct connection of spot or average temperature sensor
- Robust IP66/68, NEMA Type 4x/6P enclosure
- Operation and display in a wide variety of local languages
- Easy commissioning, maintenance, and diagnostics via FieldCare





Table of contents

Document information	3	Mechanical construction	41
Symbols	3	Dimensions	41
Function and system design	5	Weight	41
Measuring principle	5	Materials	42
Integration of tank sensors	6	Operability	43
Measuring system	15	Operating concept	43
Input/output	16	Operating options	43
Level measurement	16	Local operation	43
HART Ex ia/IS active input	17	Remote operation	44
I/O modules	18	Operation via service interface	44
Power supply	24	Certificates and approvals	45
Terminal assignment	24	CE mark	45
Sources for gauge commands	24	RCM-Tick marking	45
Supply voltage	26	Ex approval	45
Cable entries	27	Single seal according to ANSI/ISA 12.27.01	45
Cable specification	27	Functional Safety (SIL)	45
Overvoltage protection	27	WHG	45
Performance characteristics	28	Weight & Measure approval	45
Reference operating conditions	28	Non-ionizing radiation protection	45
Measured value resolution	28	CRN approval	45
Maximum measured error	28	Test, certificate	46
Hysteresis	29	Other standards and guidelines	46
Repeatability	29	Ordering information	47
Linearity	29	Ordering information	47
Long-term drift	29	Marking	47
Influence of ambient temperature	29	Shipping condition	47
Influence of medium temperature	29	Application packages	48
Influence of medium pressure	29	Advanced tank measurement methods	48
Effect of gas phase	29	Accessories	51
Installation	30	Device-specific accessories	51
Requirements	30	Communication-specific accessories	54
Environment	37	Service-specific accessories	54
Ambient temperature range	37	System components	54
Classification of environmental conditions according to DIN EN 60721-3-4	37	Documentation	55
Storage temperature	37	Technical Information (TI)	55
Humidity	37	Brief Operating Instructions (KA)	55
Degree of protection	37	Operating Instructions (BA)	55
Electromagnetic compatibility (EMC)	37	Description of Device Parameters (GP)	55
Process	38	Safety instructions (XA)	56
Process temperature range	38	Registered trademarks	57
Process pressure range	38		
Medium density	38		
Medium density difference for interface measurement	39		
Viscosity	39		
Custody transfer approval	40		







Document information

Symbols









Safety symbols

Symbol	Meaning
	DANGER! This symbol alerts you to a dangerous situation. Failure to avoid this situation will result in serious or fatal injury.
	WARNING! This symbol alerts you to a dangerous situation. Failure to avoid this situation can result in serious or fatal injury.
	CAUTION! This symbol alerts you to a dangerous situation. Failure to avoid this situation can result in minor or medium injury.
	NOTE! This symbol contains information on procedures and other facts which do not result in personal injury.



Electrical symbols

Symbol	Meaning
	Direct current
	Alternating current
	Direct current and alternating current
	Ground connection A grounded terminal which, as far as the operator is concerned, is grounded via a grounding system.
	Protective ground connection A terminal which must be connected to ground prior to establishing any other connections.
	Equipotential connection A connection that has to be connected to the plant grounding system: This may be a potential equalization line or a star grounding system depending on national or company codes of practice.



Symbols for certain types of information

Symbol	Meaning
	Permitted Procedures, processes or actions that are permitted.
	Preferred Procedures, processes or actions that are preferred.
	Forbidden Procedures, processes or actions that are forbidden.
	Tip Indicates additional information.
	Reference to documentation
	Reference to page
	Reference to graphic
	Visual inspection

Symbols in graphics

Symbol	Meaning
1, 2, 3 ...	Item numbers
1., 2., 3. ...	Series of steps
A, B, C, ...	Views
A-A, B-B, C-C, ...	Sections
	Hazardous area Indicates a hazardous area.
	Safe area (non-hazardous area) Indicates the non-hazardous area.

Symbols at the device

Symbol	Meaning
	Safety instructions Observe the safety instructions contained in the associated Operating Instructions.
	Temperature resistance of the connection cables Specifies the minimum value of the temperature resistance of the connection cables.

Function and system design

Measuring principle

NMS8x is an intelligent tank gauge for measuring liquid levels with high precision. The system is based on the principle of gauging displacement.

A small displacer is accurately positioned in a liquid medium using a stepping motor. The displacer is then suspended on a measuring wire which is wound onto a finely grooved wire drum. NMS8x counts the rotations of the wire drum and to calculate the traveling distance of the wire and obtain the liquid level change.

The drum is driven via coupling magnets that are completely separated by the drum housing. Outer magnets are connected to the wire drum, with inner magnets connected to the drive motor. As the inner magnets turn, their magnetic attraction causes the outer magnets to turn, as well, causing the entire drum assembly to turn. The weight of the displacer on the wire creates torque on the outer magnets generating change of magnetic flux. These changes generated in the drum assembly are detected by a unique electromagnetic transducer on the inner magnets. The transducer transmits the weigh signal to a CPU using a non contact principle (patented). The drive motor is actuated to keep the weigh signal constant at set value defined by the operating command.

When the displacer is lowered and touches a liquid, the weight of the displacer is reduced by liquid buoyancy force, which is measured by a temperature-compensated magnetic transducer. As a result, the torque in the magnetic coupling changes, and this is measured by six hall sensors. A signal indicating the weight of the displacer is sent to the motor control circuit. As the liquid levels rise and fall, the displacer position is adjusted by the drive motor. The rotation of the wire drum is continuously evaluated to determine the level value using a magnetic rotary encoder. In addition to gauging the level, NMS8x can measure the interfaces between up to three liquid phases, and the tank bottom, as well as spot and profile densities.

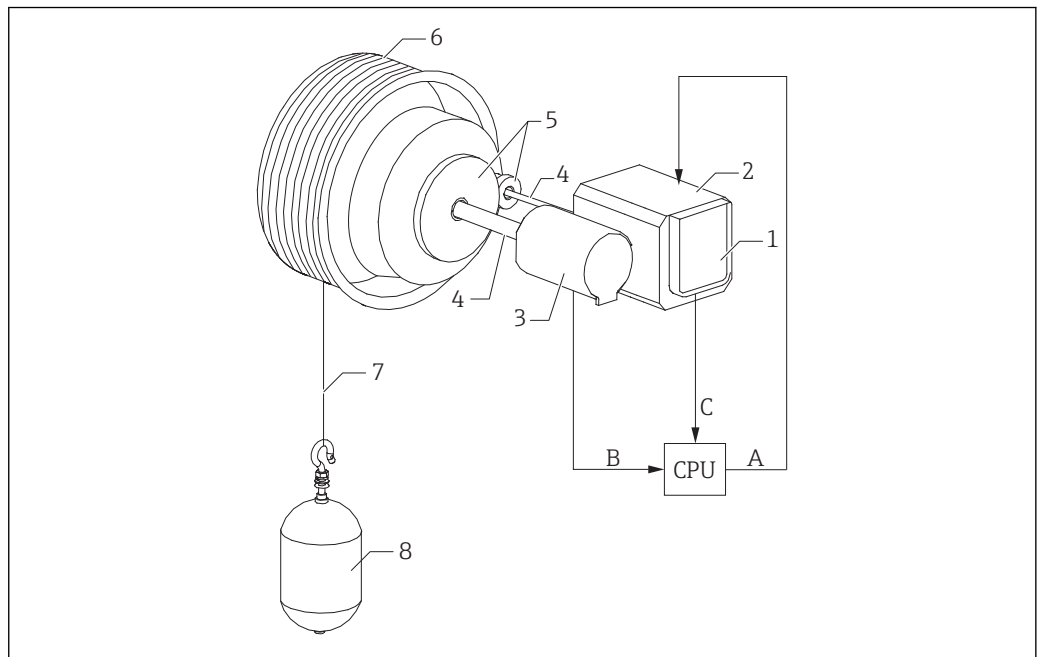

A0026724

1 Operating principle

- A Displacer position data
- B Weight data
- 1 Encoder
- 2 Motor
- 3 Rotary transformer
- 4 Shafts
- 5 Gears
- 6 Wire drum
- 7 Measuring wire
- 8 Displacer

Integration of tank sensors

In addition to measuring the level, interfaces, tank bottom, and density, the device can also be used to integrate of tank sensors into tank inventory systems. All measured and calculated system values can be displayed on the built-in display. They can be transferred to an inventory control system via a field communication protocol.

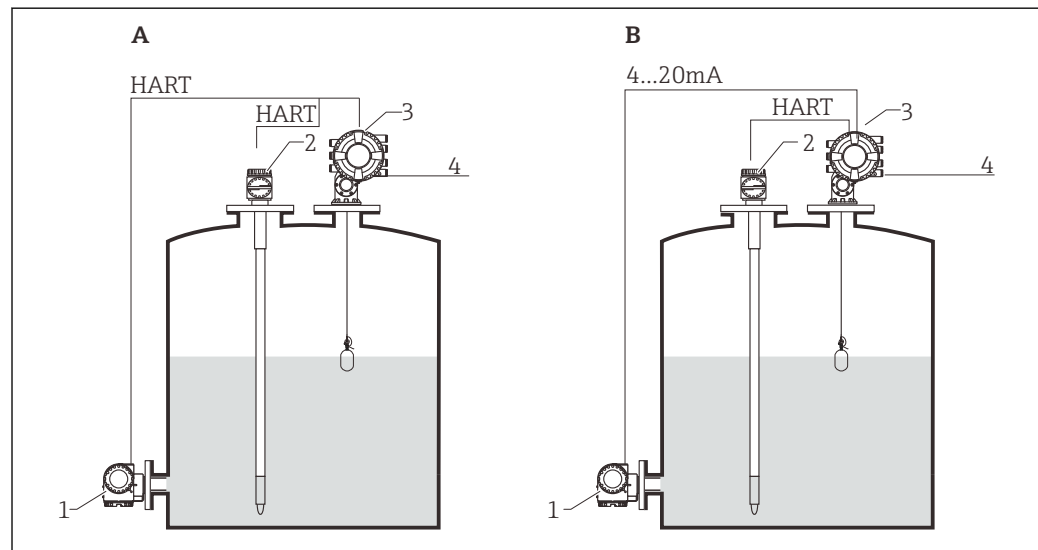

A0026722

2 Measuring system

A HART multidrop mode

B HART and analog mode

1 Pressure transmitter

2 Average temperature transmitter (NMT53x)

3 Proservo NMS8x

4 Field protocol transmits data to an inventory control system

Typical values measured by the sensors are:

- Level
- Spot temperature
- Average temperature
- Water level
- Pressure
- Secondary level value (for critical applications)

Major applications

The number of measuring functions and output options, as well as the compact design, enables NMS8x to be installed in a wide range of applications at minimal cost.

Petroleum industry

From oil production to storage at an oil depot, there exists an extensive need to measure and manage a wide variety of products. Remote tank gauging by NMS8x combined with an inventory management system is an ideal way to measure and manage tank contents.

Chemical industry

A wide choice of options for the wetted parts ensures chemical compatibility and long product life.

Power plant

Fuel oil levels are major applications where precise measurement is required to ensure safe operation.

Typical tank installation

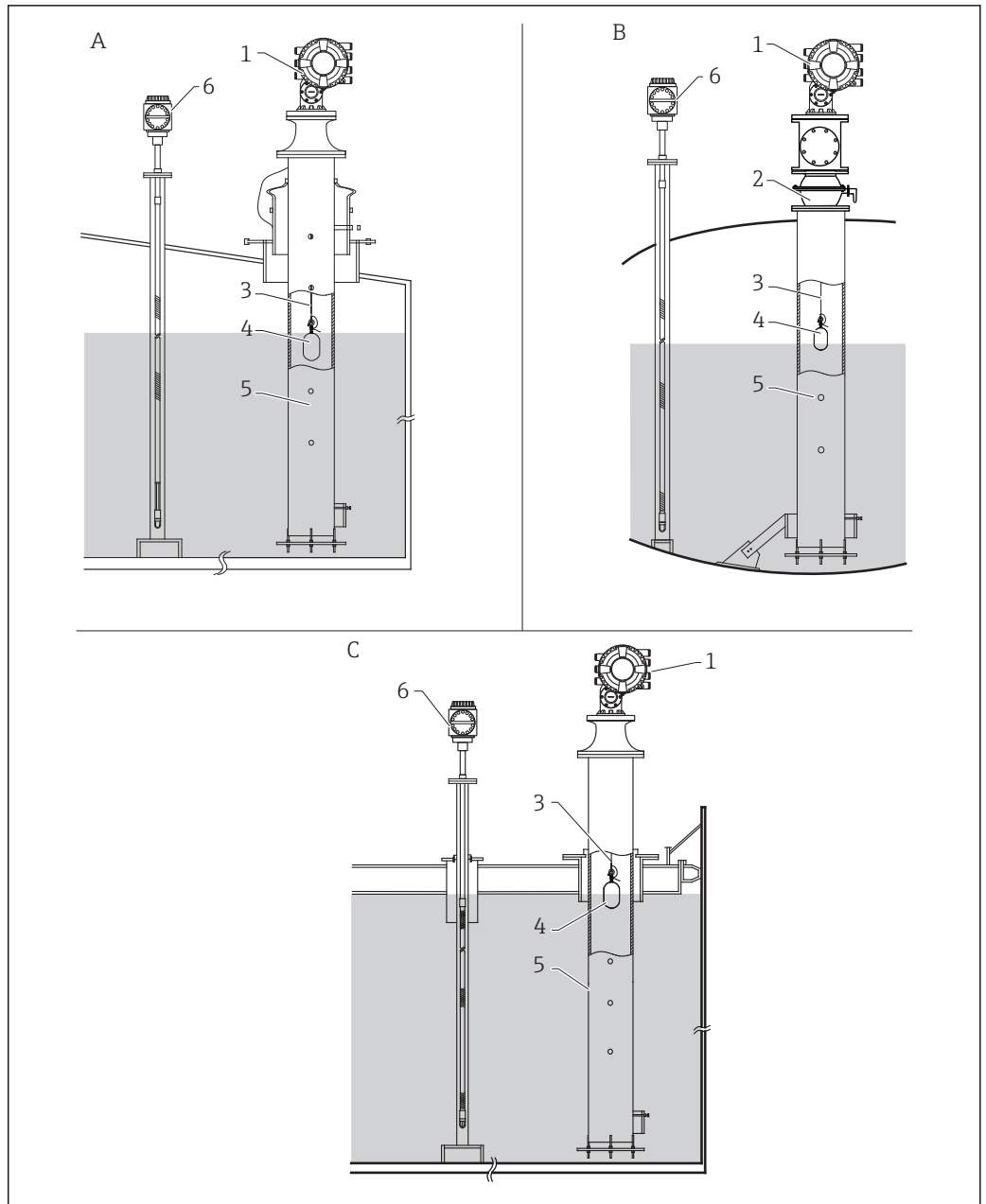

A0026725

3 Typical tank installation

- A Fixed roof tank
- B High pressure tank
- C Floating roof tank with stilling well
- 1 NMS8x
- 2 Ball valve
- 3 Measuring wire
- 4 Displacer
- 5 Stilling well
- 6 Prothermo NMT53x

i When installing NMS8x to a floating roof tank, be sure to use a stilling well to protect the measuring wire. Otherwise the wire may break due to an external shock.

Application

NMS8x is primarily a highly accurate level measurement gauging instrument with the added ability to measure density. The following level measurements are supported: liquid surface level and interface level(s) between different liquids, as well as finding tank floor or datum plate. The

following density measurements are supported: single-point (spot measurements), as well as profile measurements of all liquid(s) in a tank.

The choice of the most suitable displacer depends on the liquid conditions and measurement functions. These can be classified as follows:

- Single measurement value only, e.g. level, interface, or density
- Multiple measurement application, e.g. level, interface, and density

Measurement terminology

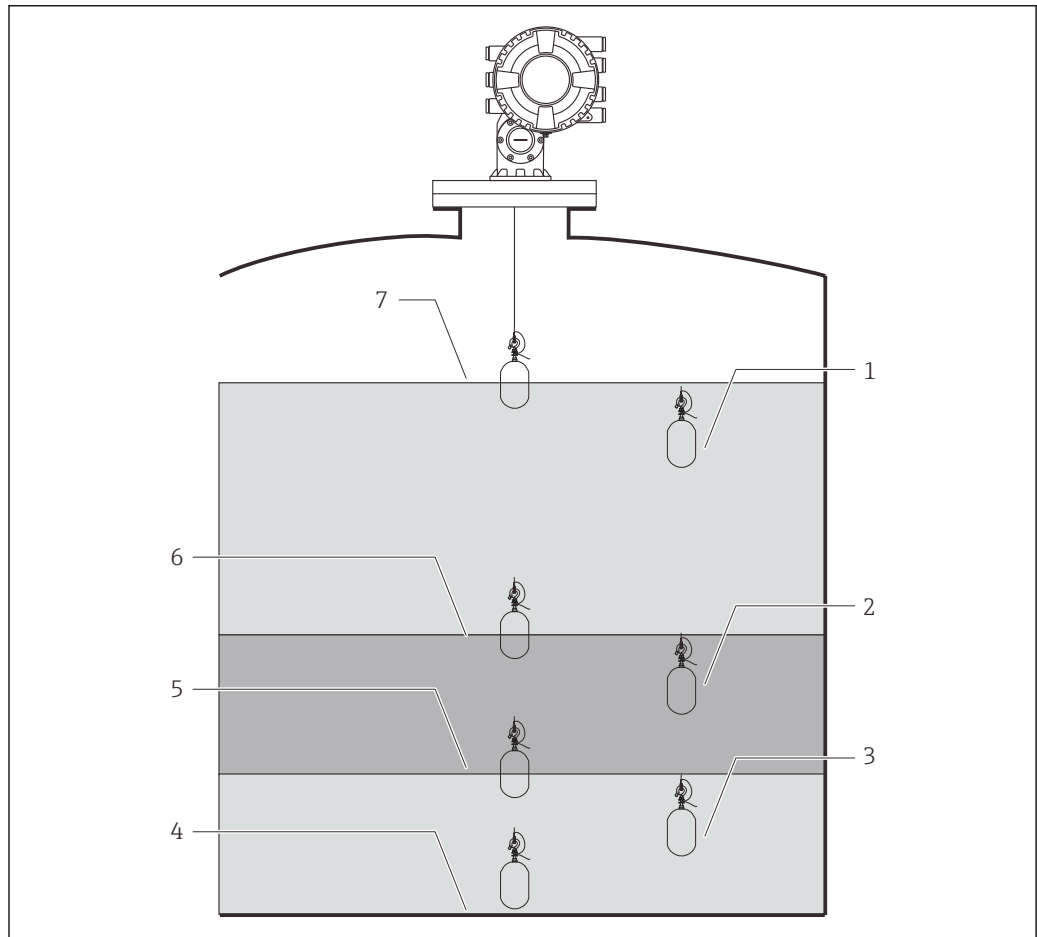

A0026727

4 NMS8x with standard level, I/F x 2, Tank bottom and spot density x 3 measurement

- 1 Upper density
- 2 Middle density
- 3 Lower density
- 4 Tank bottom
- 5 Lower I/F
- 6 Upper I/F
- 7 Level

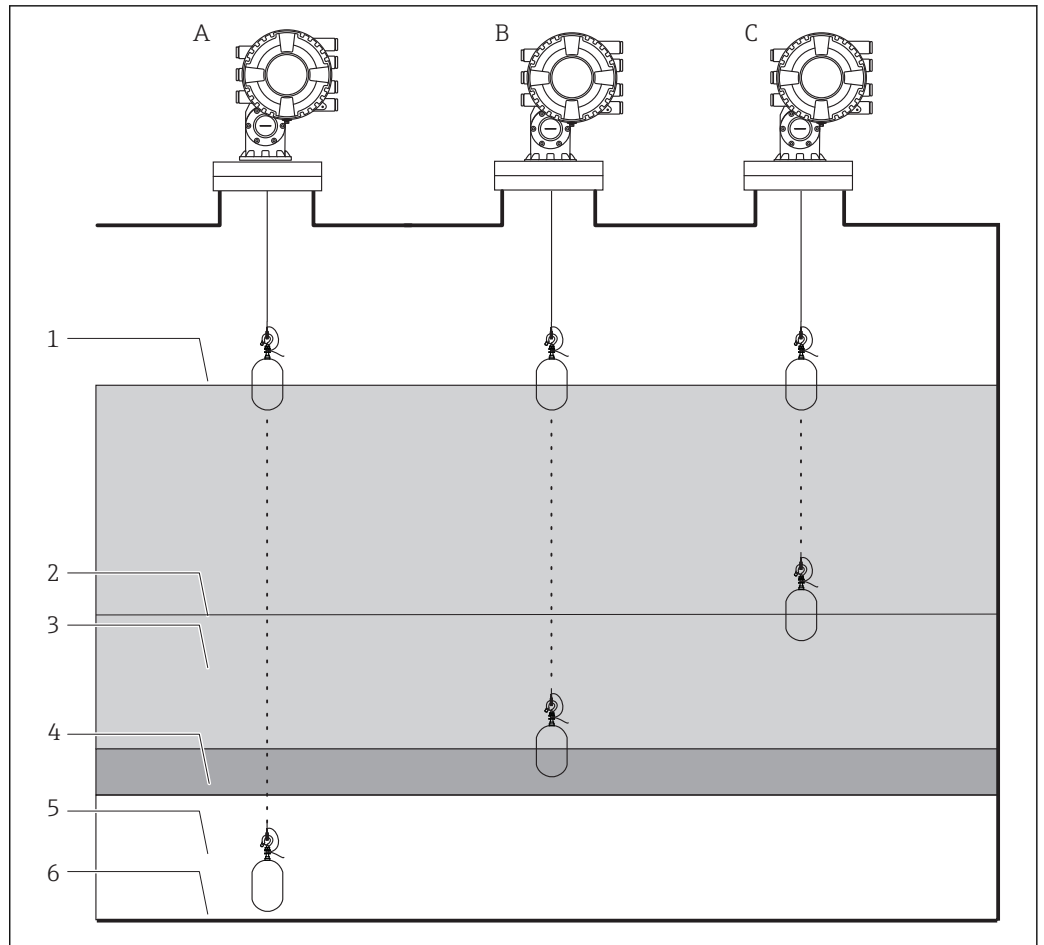

A0026728

5 Density Profile measurement

- A Tank profile: density profiling throughout tank
- B Interface profile: density profiling withing upper phase
- C Manual profile: density profiling from a specific position to level
- 1 Level
- 2 Manual profile level
- 3 Upper phase (oil)
- 4 Middle phase (emulsion)
- 5 Lower phase (water)
- 6 Tank bottom

Displacer selection guide

A wide variety of displacers are available to suit different application. Proper displacer selection ensures optimal performance and longevity. The following guidelines will assist you in selecting the most suitable displacer for your application.

Displacer types

The following NMS8x displacers are available.

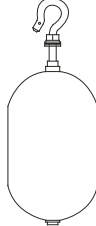
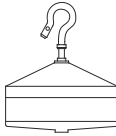
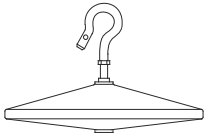
30 mm (1.18 in)	50 mm (1.97 in)	70 mm (2.76 in)	110 mm (4.33 in)
316L/PTFE	316L/Alloy C/PTFE	316L	316L
 <p style="text-align: right; margin-right: 10px;">A0026729</p>	 <p style="text-align: right; margin-right: 10px;">A0026730</p>	 <p style="text-align: right; margin-right: 10px;">A0026731</p>	 <p style="text-align: right; margin-right: 10px;">A0026732</p>

Displacer dimensions

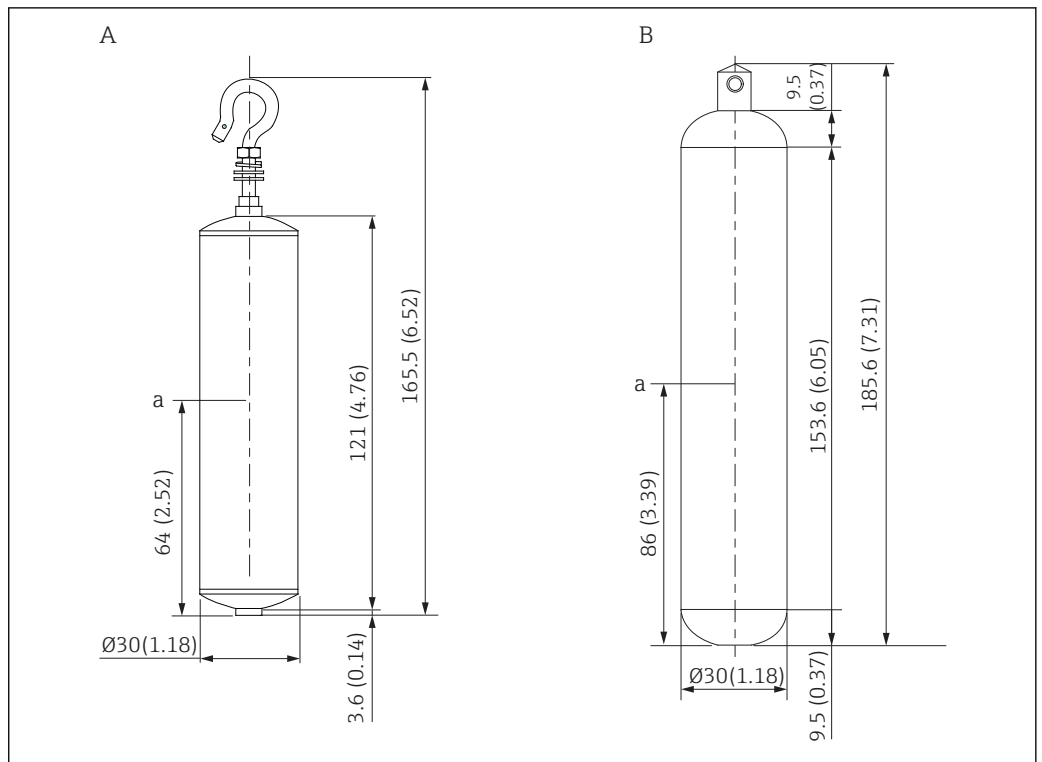

A Ø30 mm (1.18 in) 316L cylindrical displacer
 B Ø30 mm (1.18 in) PTFE cylindrical displacer
 a Immersion point

Item	Ø30 mm (1.18 in) 316L cylindrical displacer	Ø30 mm (1.18 in) PTFE cylindrical displacer
Weight (g)	261	250
Volume (ml)	84.3	118
Balance volume (ml)	41.7	59

i The weight, volume, and balance volume are individually determined by each displacer and also might vary depending on the values stated above.

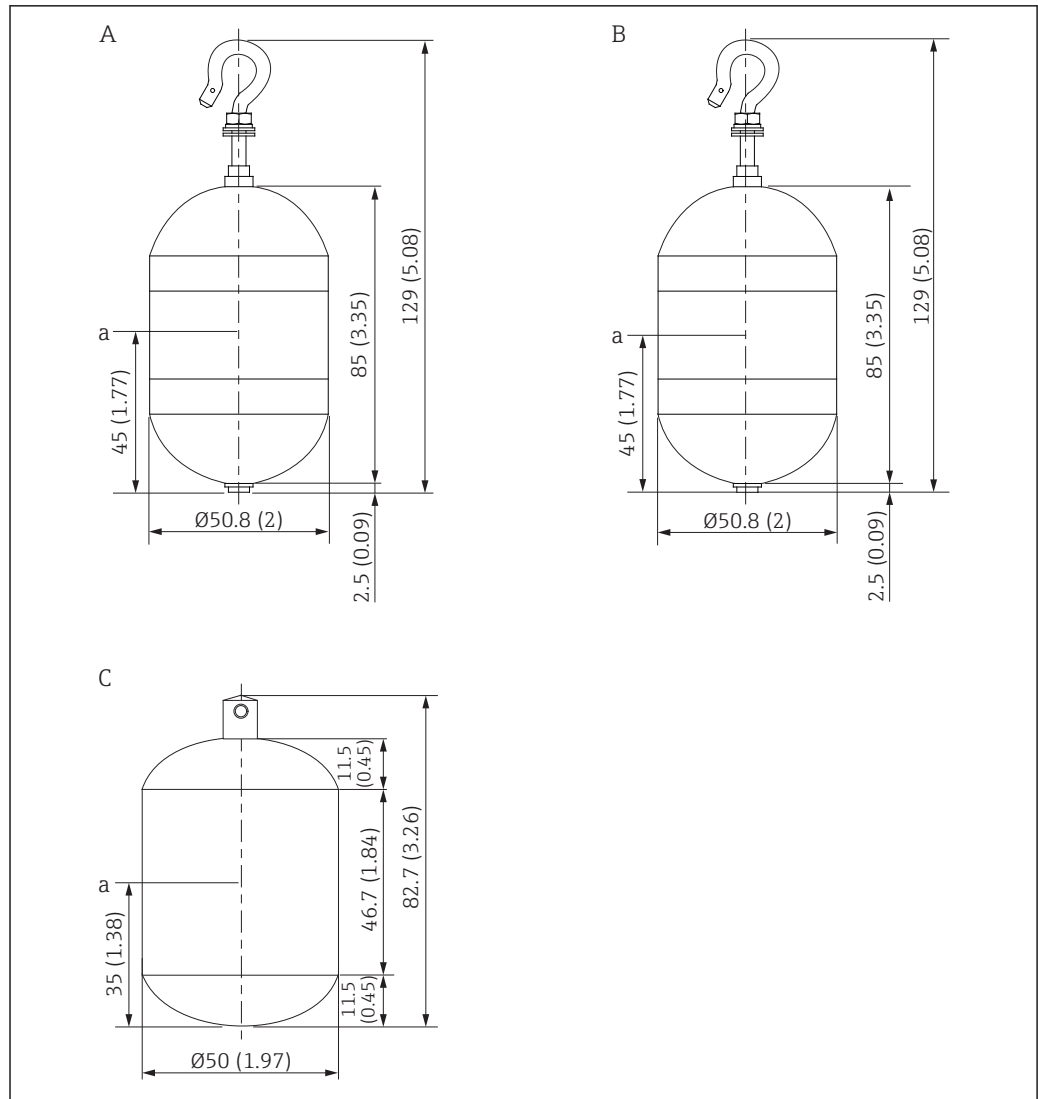

A0029580

- A Ø50 mm (1.97 in) 316L cylindrical displacer
- B Ø50 mm (1.97 in) AlloyC cylindrical displacer
- C Ø50 mm (1.97 in) PTFE cylindrical displacer
- a Immersion point

Item	Ø50 mm (1.97 in) 316L cylindrical displacer	Ø50 mm (1.97 in) AlloyC cylindrical displacer	Ø50 mm (1.97 in) PTFE cylindrical displacer
Weight (g)	253	253	250
Volume (ml)	143	143	118
Balance volume (ml)	70.7	70.7	59

i The weight, volume, and balance volume are individually determined by each displacer and also might vary depending on the values stated above.

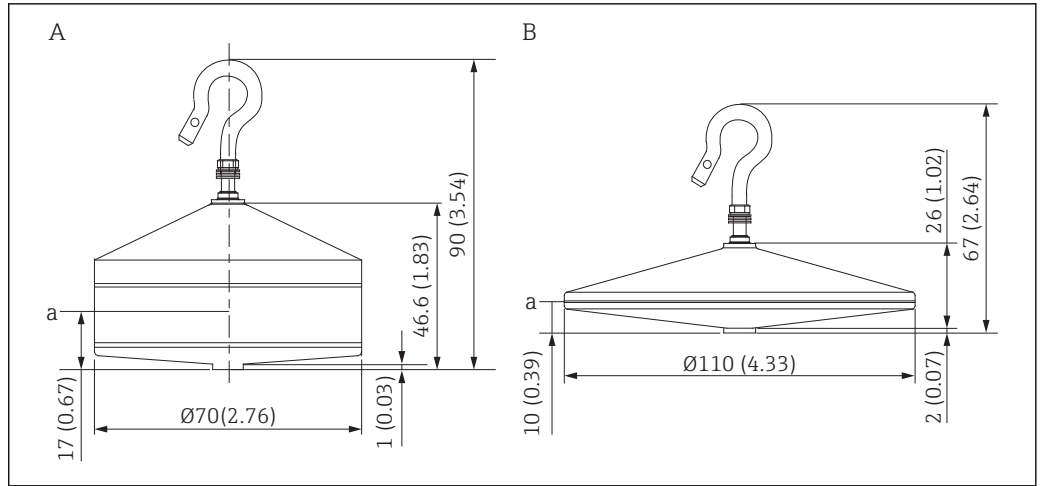

A0029582

A $\varnothing 70$ mm (2.76 in) 316L conical displacer
 B $\varnothing 110$ mm (4.33 in) 316L conical displacer
 a Immersion point

Item	$\varnothing 70$ mm (2.76 in) 316L conical displacer	$\varnothing 110$ mm (4.33 in) 316L conical displacer
Weight (g)	245	223
Volume (ml)	124	108
Balance volume (ml)	52.8	36.3

i The weight, volume, and balance volume are individually determined by each displacer and also might vary depending on the values stated above.

Recommended displacer by application

Application	Product level	Interface level	Density
Viscous liquid	50 mm (1.97 in) PTFE	Not Recommended	Not Recommended
Crude oil	50 mm (1.97 in) 316L 50 mm (1.97 in) PTFE	50 mm (1.97 in) 316L 50 mm (1.97 in) PTFE	50 mm (1.97 in) 316L 50 mm (1.97 in) PTFE
Black oil	50 mm (1.97 in) 316L	50 mm (1.97 in) 316L	50 mm (1.97 in) 316L
White oil	70 mm (2.76 in) 316L	70 mm (2.76 in) 316L	70 mm (2.76 in) 316L
Liquefied gas, LPG/LNG	70 mm (2.76 in) 316L	70 mm (2.76 in) 316L	70 mm (2.76 in) 316L
Corrosive liquid	50 mm (1.97 in) Alloy C 50 mm (1.97 in) PTFE	50 mm (1.97 in) Alloy C 50 mm (1.97 in) PTFE	50 mm (1.97 in) Alloy C 50 mm (1.97 in) PTFE

Product level

In general, larger diameter displacers have better accuracy under similar conditions.

Interface level(s)

Cylindrical-shaped displacers, with rounded top and bottom, reduce resistance while moving through liquid(s). This provides smoother movement and faster interface measurements compared to flat-faced displacers, particularly in density profile measurements that span the full tank height.

i In order to move a displacer down through liquids, the displacer density (weight divided by volume) must be higher than the liquid density.

Tank bottom and datum plate level

70 mm (2.76 in) and 50 mm (1.97 in) displacers reduce resistance while moving through liquids. This provides smoother movement and faster interface measurements.

Density

Since the density is the calculated result of two measurements, a displacer with higher volume will usually yield the most accurate density measurement. In most cases we recommend our 50 mm (1.97 in) diameter displacer for density measurement.

For non-viscous applications (e.g. white oil, LPG/LNG), the 70 mm (2.76 in) displacer also works very well.

Level and density

When an application calls for equal emphasis on measuring both level and density, the 50 mm (1.97 in) and the 70 mm (2.76 in) diameter displacers will give the best all-around performance.

Custody transfer

The 50 mm (1.97 in) displacer or larger is the choice for requirements per NMI.

The 110 mm (4.33 in), conical 316L displacer is the choice for requirements per PTB.

Material compatibility

Displacers are available in three different standard materials. Material compatibility should be confirmed to ensure safe operation and optimal NMS8x performance.

316L

Stainless steel is a highly versatile industrial material that provides good compatibility with a wide range of chemicals, including most white and black oils.

Alloy C

This high-performance material is harder than 316L, and provides excellent resistance to many of the harshest corrosive chemical applications.

PTFE

One of the most well-known and versatile polymer materials, this high-performance material has one of the lowest friction coefficients. It provides excellent performance in viscous/sticky liquids, and also has excellent chemical resistance to a wide range of corrosives.

Process connection size

The process connection defines the tank process entry, and may affect the displacer size. The standard NMS8x process connections start at 3"/DN80 and fit most tank gauging applications. Accordingly, most applications can be covered with one of the 50mm or 70mm displacer options. Smaller diameter displacers are available when the process connection is smaller.



When the 110 mm (4.33 in) diameter custody transfer approval (PTB) displacer is selected, a separate calibration and maintenance chamber is recommended between the NMS8x and tank process connection.

Measuring system

- From single tank level measurement to the largest oil refinery applications, Endress+Hauser tank gauging devices are an integral part of tank farm management solutions. A wide variety of data output protocols are available for seamless integration into many commonly used systems.
- A primary example is Tankvision from Endress+Hauser. Tankvision is a scalable system offering local tank management for multiple loops via Modbus or V1 protocols. Accumulated data is available to DCS and other plant management systems via a Host Link.

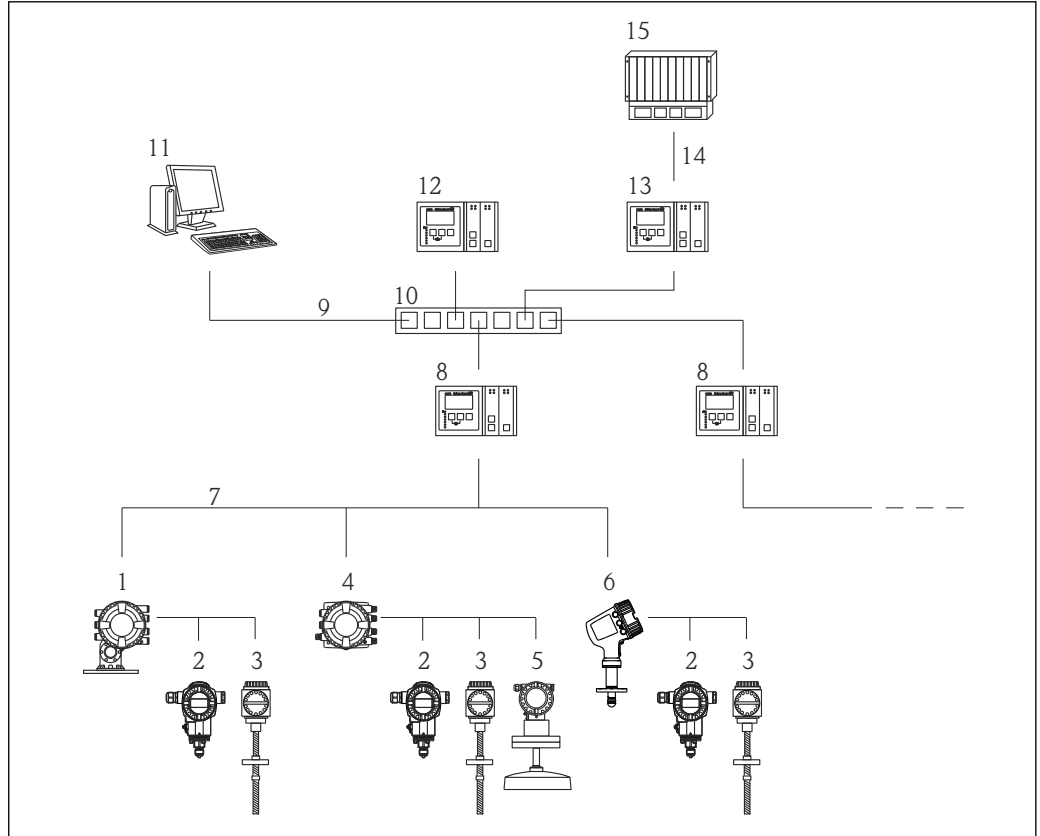

A0027700

6 Integration of tank gauging devices into an inventory management system (typical example)

- 1 Proservo NMS8x
- 2 Pressure transmitter (e.g. Cerabar)
- 3 Temperature transmitter (e.g. Prothermo)
- 4 Tankside Monitor NRF81
- 5 Micropilot S FMR5xx
- 6 Micropilot NMR8x
- 7 Field protocol (e.g. Modbus, V1)
- 8 Tankvision Tank Scanner NXA820
- 9 Ethernet
- 10 Ethernet switch
- 11 Internet Browser
- 12 Tankvision Data Concentrator NXA821
- 13 Tankvision Host Link NXA822
- 14 Modbus
- 15 DCS or PLC

Input/output

Level measurement

Measured variable

Proservo is primarily a highly accurate level measurement gauging instrument, with the added ability to measure interfaces and densities. The following level measurements are supported: liquid surface level and interface level(s) between different liquids, as well as finding tank bottom or datum plate. The following density measurements are supported: single-point (called "spot" measurements), as well as profile measurements of all liquid(s) in a tank.

Measuring range

- Level and interface: Max.36 m (118 ft)(longer range is possible as special product)
- Density: 0.430 to 2.000 g/cm³

The level and interface measuring range depends on the measuring wire and material compatibility to measured medium. Measuring wires are available in three different standard materials. Material compatibility should be confirmed to ensure safe operation and optimal measuring performance.

Measuring range	Material
28 m (93.33 ft), 36 m (120 ft)	316L
16 m (53.33 ft)	PFA > 316L
22 m (73.33 ft)	AlloyC276

HART Ex ia/IS active input

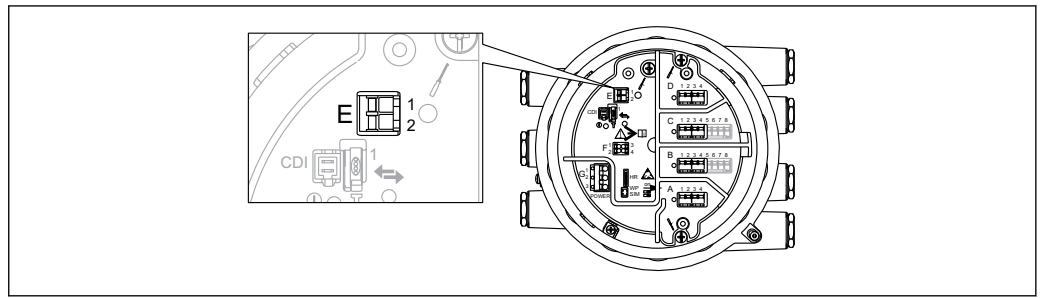

A0027364

7 HART Ex ia/IS active input

- E1 HART +
- E2 HART -

The device has a HART Ex ia/IS active input. Additional features are provided if the following Endress+Hauser devices are connected:

Prothermo NMT

The measured level is transmitted to the Prothermo. Prothermo uses this level to calculate the average temperature of the product.

Technical data

Transmitter power supply voltage	23.0 V - $380 \Omega \cdot I_{load}$
Maximum load	500 Ω including signal line
Maximum current of all connected devices	24 mA

i The HART Ex ia/IS active input is available by default. It needs not to be chosen explicitly when ordering a device.

Overview

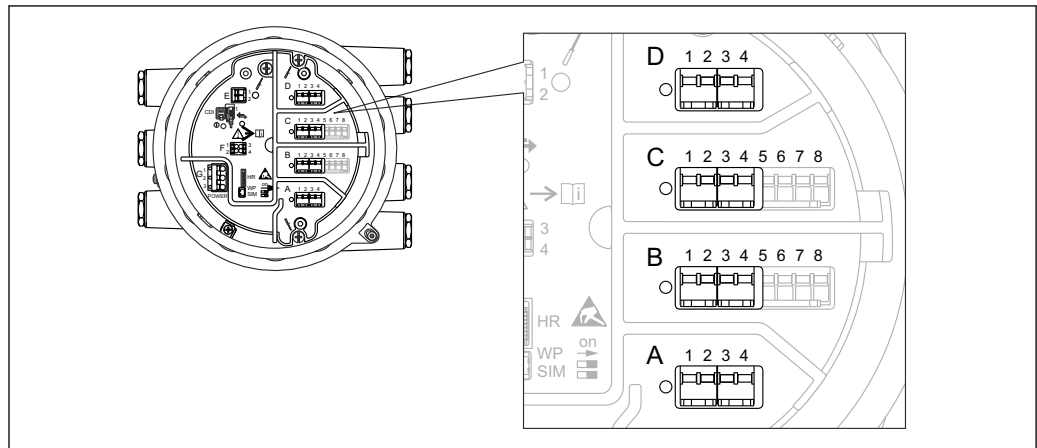

A0027363

8 Position of the I/O modules in the terminal compartment

The terminal compartment contains up to four I/O modules, depending on the order code.

- Modules with four terminals can be in any of these slots.
- Modules with eight terminals can be in slot B or C.

i The exact assignment of the modules to the slots is dependent on the device version. For a detailed description refer to the Operating Instructions of the device in question.

- i** The following restrictions apply when selecting the modules:
- The device may contain a maximum of four I/O modules.
 - A maximum of two I/O modules with 8 terminals is possible.

Ordering feature 040: "Primary Output"

NMx8x - xxxx <u>XX</u> xx xx ... 040				
Option	Number of I/O modules	Type of I/O module	Number of terminals	Technical data
A1	1	Modbus RS485	4	→ 19
B1	1	V1	4	→ 20
E1	1	4-20mA HART Ex d/XP	8	→ 21
H1	1	4-20mA HART Ex i/IS	8	→ 21

Ordering feature 050: "Secondary IO Analogue"

NMx8x - xxxx xx <u>XX</u> xx ... 050				
Option	Number of I/O modules	Type of I/O module	Number of terminals	Technical data
A1	1	1 x "Ex d/XP 4-20mA HART + RTD input"	1 x 8	→ 21
A2	2	2 x "Ex d/XP 4-20mA HART + RTD input"	2 x 8	→ 21
B1	1	1 x "Ex i/IS 4-20mA HART+ RTD input"	1 x 8	→ 21
B2	2	2 x "Ex i/IS 4-20mA HART+ RTD input"	2 x 8	→ 21
C2	2	1 x "Ex i/IS 4-20mA HART + RTD input" 1 x "Ex d/XP 4-20mA HART + RTD input"	2 x 8	→ 21
X0	0	none	0	-

Ordering feature 060: "Secondary IO Digital Exd"

NMx8x - xxxx xx xx <u>XX</u> ... 060				
Option	Number of I/O modules	Type of I/O module	Number of terminals	Technical data
A1	1	1 x "2x relay + 2x discrete I/O"	1 x 4	→ 23
A2	2	2 x "2x relay + 2x discrete I/O"	2 x 4	→ 23
A3	3	3 x "2x relay + 2x discrete I/O"	3 x 4	→ 23
B1	1	1x "Modbus RS485"	1 x 4	→ 19
B2	2	1x "Modbus RS485" 1 x "2x relay + 2x discrete I/O"	2 x 4	→ 19 → 23
B3	3	1x "Modbus RS485" 2 x "2x relay + 2x discrete I/O"	3 x 4	→ 19 → 23
X0	0	none	0	-

"Modbus RS485": Technical data

No. of units	Maximum 15 instruments per loop
Baud rate	Selectable: <ul style="list-style-type: none"> ▪ 600 bit/s ▪ 1200 bit/s ▪ 2400 bit/s ▪ 4800 bit/s ▪ 9600 bit/s ▪ 19200 bit/s
Parity	Selectable: <ul style="list-style-type: none"> ▪ Odd ▪ Even ▪ None
Cable	Three-wire cable with screening. The screening must be connected inside the housing.
Termination resistors	To be set as required in specific environments
Topology	<ul style="list-style-type: none"> ▪ Serial bus ▪ Tree structure
Transmission distance	Maximum 1200 m (3900 ft) including limbs or branches; branches under 3 m (9.8 ft) are negligible
Instrument address	Each transmitter has an individual bus address configured in the software of the transmitter.
Isolation	Bus inputs are electrically isolated from the other electronics.
Error on alarm	Error message classified according to NAMUR NE 107

"V1": Technical data

No. of units	Maximum 10 instruments per loop
Baud rate	3 300 bit/s
Parity	Selectable: <ul style="list-style-type: none">▪ Odd▪ Even▪ None
Cable	<ul style="list-style-type: none">▪ Two-wire twisted pair; screening recommended▪ Two-wire unshielded
Termination resistors	Not required
Topology	<ul style="list-style-type: none">▪ Serial bus▪ Tree structure
Transmission distance	Maximum 6 000 m (19 700 ft)
Instrument address	Each transmitter has an individual bus address configured in the software of the transmitter.
Isolation	Serial communication circuit isolated from other circuits
Error on alarm	Error message classified according to NAMUR NE 107

"4-20mA HART" I/O module (Ex d/XP or Ex i/IS): Technical data*General data*

No. of units	Max. 6 instruments per loop
Baud rate	1 200 bit/s
Cable	Two-wire, twisted pair screened cable; Core cross section: 0.2 to 2.5 mm ² (24 to 13 AWG)
Topology	<ul style="list-style-type: none"> ▪ Serial bus ▪ Tree structure
Transmission distance	Maximum 1 200 m (3 900 ft)
Instrument address	Each transmitter on a signal loop has an individual bus address. This is defined within the transmitter software and / or auxiliary configuration environment such as host system or Field Communicator 475.
Isolation	Bus inputs are electrically isolated from the other electronics

Input data

Input operating modes	<ul style="list-style-type: none"> ▪ 4..20mA input (1 external device) ▪ HART master+4..20mA input (1 external device) ▪ HART master (up to 6 external devices)
Internal load (to ground)	400 Ω
Measuring range	0 to 26 mA
Accuracy	±15 µA (after linearization and calibration)
Connection of a Prothermo NMT	The measured level is transmitted to the Prothermo. Prothermo uses this level to calculate the average temperature of the product.
Connection of a RTD temperature probe	2-, 3- or 4-wire connection

Output data

Output operating modes	<ul style="list-style-type: none"> ▪ 4..20mA output ▪ HART slave +4..20mA output
Output current	3 to 24 mA
Accuracy	±15 µA (after linearization and calibration)
Error on alarm	HART error message classified according to NAMUR NE 107

Data for passive usage (input or output)

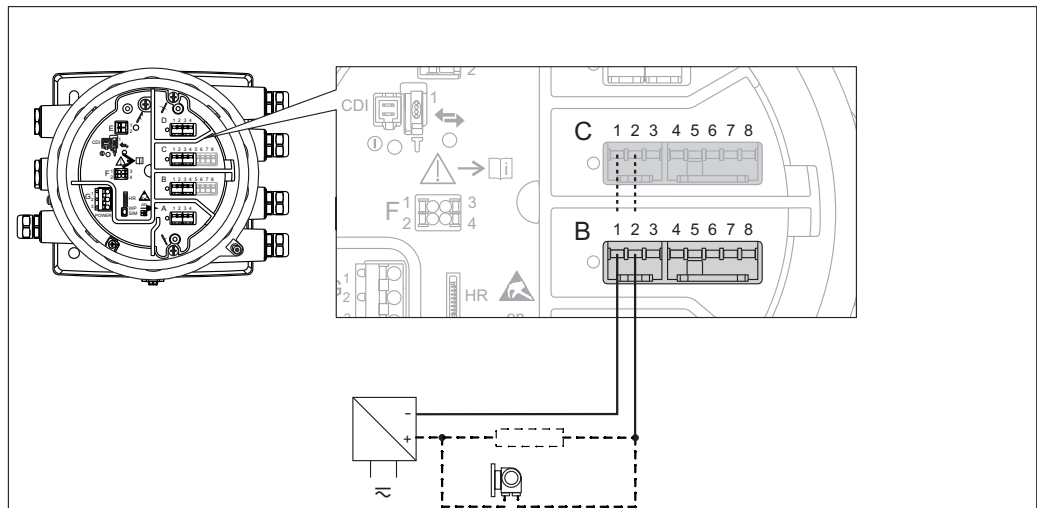

A0033030

9 Passive input or output: Use terminals 1 and 2

Minimum terminal voltage	10.4 V ¹⁾
Maximum terminal voltage	29 V ¹⁾

1) Observing these values is mandatory in order to ensure correct measured value information.

Data for active usage (input or output)

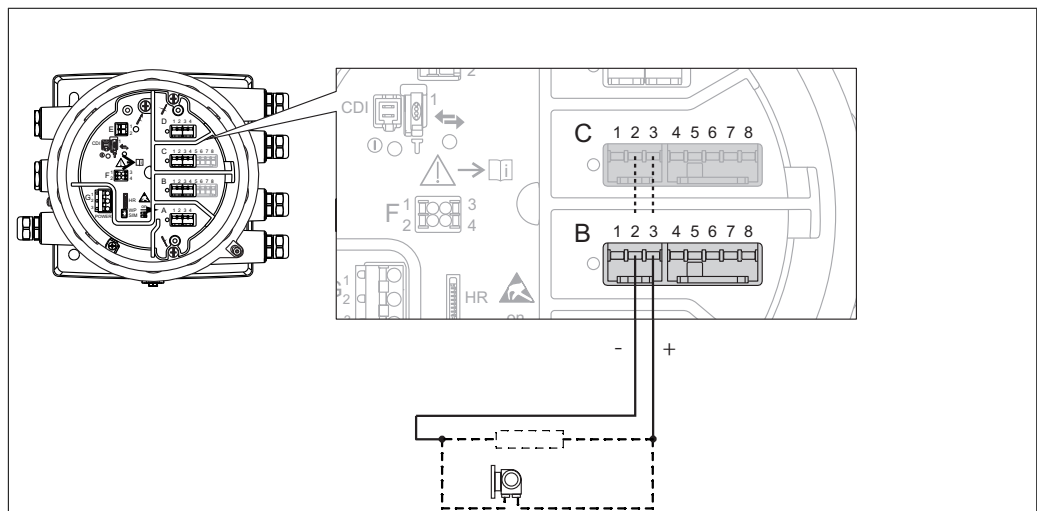

A0033031

10 Active input or output: Use terminals 2 and 3

Transmitter power supply voltage (Ex d/XP)	18.5 V - 360 Ω · I _{load}
Transmitter power supply voltage (Ex i/IS)	20.0 V - 360 Ω · I _{load}
Output load	max. 500 Ω including signal line ¹⁾

1) Observing this value is mandatory in order to ensure correct measured value information.

"Digital I/O module": Technical data

Output	
Relay switching power for resistive load	<ul style="list-style-type: none"> ▪ 30 V_{DC} @ 2 A ▪ 250 V_{DC} @ 0.1 A ▪ 250 V_{AC} @ 2 A
Relay type	normally open; can be set to "normally closed" by a software option ¹⁾
Input	
Maximum pick-up voltage	<ul style="list-style-type: none"> ▪ 250 V_{AC} ▪ 250 V_{DC}
Minimum pick-up voltage	<ul style="list-style-type: none"> ▪ 25 V_{AC} ▪ 5 V_{DC}
Current consumption at maximum voltage	<ul style="list-style-type: none"> ▪ ≤ 1 mA (DC) ▪ ≤ 2 mA (AC)

- 1) In case of a power supply failure, the switching state is always "open", irrespectiv of the selected software option.

Power supply

Terminal assignment

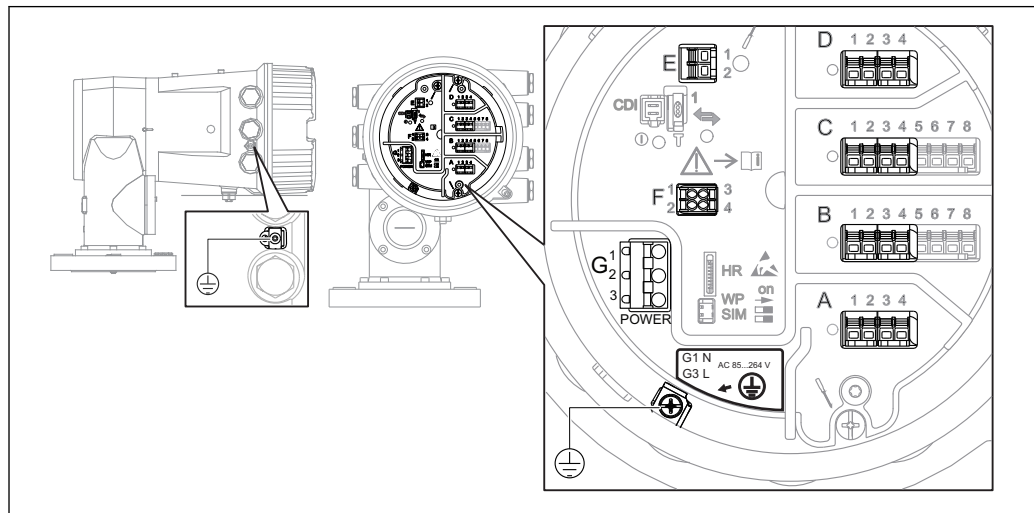

A0026905

11 Terminal compartment (typical example) and ground terminals

Terminal area	Module
A/B/C/D (slots for I/O modules)	<p>Up to four I/O modules, depending on the order code</p> <ul style="list-style-type: none"> Modules with four terminals can be in any of these slots. Modules with eight terminals can be in slot B or C. <p>i The exact assignment of the modules to the slots is dependent on the device version. For a detailed description refer to the Operating Instructions of the device in question.</p>
E	<p>HART Ex i/IS interface</p> <ul style="list-style-type: none"> E1: H+ E2: H-
F	<p>Remote display</p> <ul style="list-style-type: none"> F1: V_{CC} (connect to terminal 81 of the remote display) F2: Signal B (connect to terminal 84 of the remote display) F3: Signal A (connect to terminal 83 of the remote display) F4: Gnd (connect to terminal 82 of the remote display)
G	<p>Power consumption: 28.8 VA ¹⁾</p> <p>Power supply: 85 to 264 V_{AC}</p> <ul style="list-style-type: none"> G1: N G2: not connected G3: L
	<p>Protective ground connection (M4 screw)</p>

A0018339

1) Maximum power varies depending on the configuration of the modules. As the value of 28.8 VA shows maximum apparent power, select the applicable cables accordingly. The actual consumed effective power is 12 w.

Sources for gauge commands

Gauge commands can be sent via various sources.

- Displays or CDI (e.g. FieldCare)
- Digital input (e.g. switch)
- Fieldbus (Modbus, V1, HART)

The last received gauge command via any sources will be executed as usual.

i During calibration, gauge commands are not accepted from any sources.

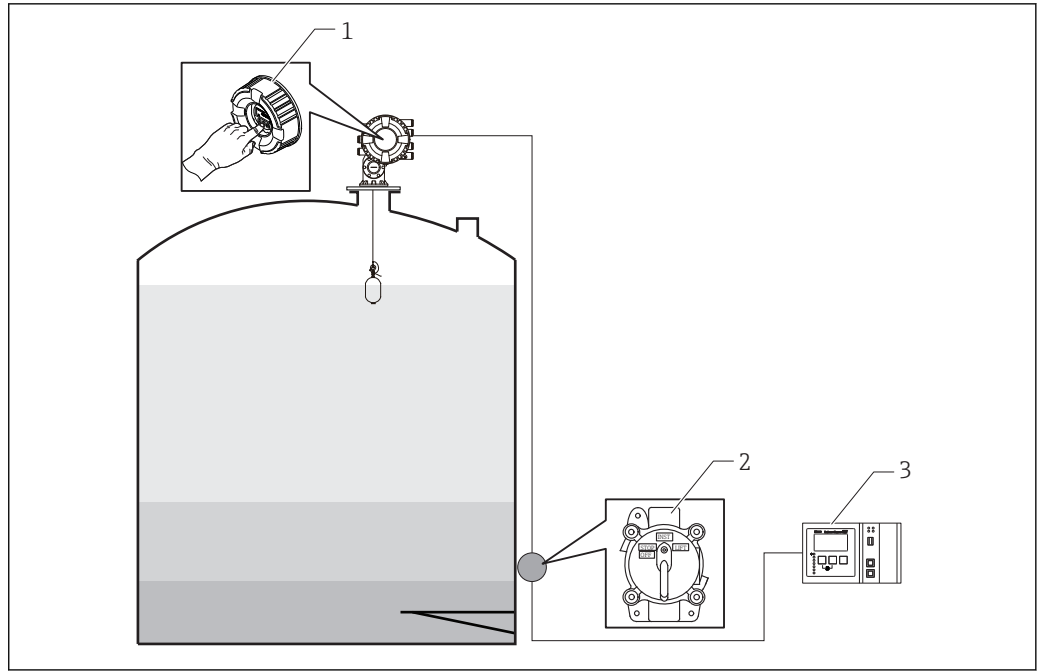

A0029538

- 1 Display operation
- 2 Digital input (e.g. switch)
- 3 Tankvision

Gauge command priorities

The priority of the gauge command for NMS8x is very simple. The last received gauge command via any sources will be executed to take of the former gauge command. However the priority varies depending on the devices. When replacing the device with the NMS8x, check the priorities shown below.

NOTICE

Undesired gauge command will be executed.

If the setting is not changed, an undesired gauge command will be executed (e.g. Level command via Fieldbus would overwrite Stop command for maintenance.).

- ▶ If the system has been automatically or semi-automatically programmed for operation, maintenance or other purposes, the setting should be changed corresponding to use.

Proservo NMS8x

By display		From digital input		From Fieldbus	
Command	Priority	Command	Priority	Command	Priority
Level	1	Level	1	Level	1
Interface	1	Interface	1	Interface	1
Tank bottom	1	Tank bottom	1	Tank bottom	1
Spot density	1	Spot density	1	Spot density	1
Profile density	1	Profile density	1	Profile density	1
Up	1	Up	1	Up	1
Stop	1	Stop	1	Stop	1

Proservo NMS5/NMS7

By display		From NRF560		From digital input		From Fieldbus	
Command	Priority	Command	Priority	Command	Priority	Command	Priority
Level	4	Level	4	Level	4	Level	4
Interface	2	Interface	3	Interface	1	Interface	4
Tank bottom	2	Tank bottom	3	N/A	N/A	Tank bottom	4
Spot density	2	Spot density	3	N/A	N/A	Spot density	4
Profile density	2	Profile density	3	N/A	N/A	Profile density	4
Up	2	Up	3	Up	1	Up	4
Stop	2	Stop	3	Stop	1	Stop	4

Servo level gauge TGM5

By display		From NRF560		From DRM9700		From digital input		From Fieldbus	
Command	Priority	Command	Priority	Command	Priority	Command	Priority	Command	Priority
Level	4	Level	4	Level	4	Level	4	Level	4
Interface	2	Interface	3	N/A	N/A	N/A	N/A	Interface	4
Tank bottom	2	Tank bottom	3	N/A	N/A	N/A	N/A	Tank bottom	4
Spot density	2	Spot density	3	N/A	N/A	N/A	N/A	Spot density	4
Profile density	2	Profile density	3	N/A	N/A	N/A	N/A	Profile density	4
Up	2	Up	3	Up	1	Up	1	Up	4
Stop	2	Stop	3	N/A	N/A	Stop	1	Stop	4

Servo level gauge TGM4000

By display		From DRM9700		From digital input		From Fieldbus	
Command	Priority	Command	Priority	Command	Priority	Command	Priority
Level	4	Level	4	Level	4	Level	4
Interface	2	Interface	1	N/A	N/A	Interface	4
Tank bottom	2	N/A	N/A	N/A	N/A	Tank bottom	4
Spot density	2	N/A	N/A	N/A	N/A	Spot density	4
Profile density	2	N/A	N/A	N/A	N/A	Profile density	4
Up	2	Up	1	Up	1	Up	4
Stop	2	Stop	N/A	Stop	1	Stop	4

Supply voltage85 to 264 V_{AC}, 50/60 Hz, 28.8 VA¹⁾

1) maximum value; actual value depending on modules installed. 28.8 VA includes the nominal power and the cabling specification has to meet this value. On the other hand, the effective power consumption is 12 W.

Cable entries

Ordering feature 090 "Electrical Connection" ¹⁾	Cable entries (with blind plugs)
A	7 x thread M20
B	7 x thread M25
C	7 x thread G1/2
D	7 x thread G3/4
E	7 x thread NPT1/2
F	7 x thread NPT3/4

1) Position 13 of the order code, e.g. NMx8x-xxxxxxxxxxxxA...



For the following devices with TIIS Ex d approval, cable glands are attached to the device (see position 1 and 2 of the order code). These cable glands must be used.
Proservo NMS80-TC...

Cable specification

Terminals

Terminal	Wire cross section
Signal and power supply <ul style="list-style-type: none"> ▪ Spring terminals (NMx8x-xx1...) ▪ Screw terminals (NMx8x-xx2...) 	0.2 to 2.5 mm ² (24 to 13 AWG)
Ground terminal in the terminal compartment	max. 2.5 mm ² (13 AWG)
Ground terminal at the housing	max. 4 mm ² (11 AWG)

Power supply line

Standard device cable is sufficient for the power line.

HART communication line

- Standard device cable is sufficient if only the analog signal is used.
- Shielded cable is recommended if using the HART protocol. Observe the grounding concept of the plant.

Modbus communication line

- Observe the cable conditions from the TIA-485-A, Telecommunications Industry Association.
- Additional conditions: Use shielded cable.

V1 communication line

- Two wire (twisted pair) screened or un-screened cable
- Resistance in one cable: ≤ 120 Ω
- Capacitance between lines: ≤ 0.3 µF

Overvoltage protection

On the communication and power lines; according to IEC 60060-1 /DIN 60079-14:
10 kA, 8/20 µs, 10 pulses according to IEC 60060-1 / DIN 60079-14

Performance characteristics

Reference operating conditions According to OIML R85

Measured value resolution	Level and interface	≤ 0.1 mm (0.004 in)
	Density	≤ 0.001 g/cm ³

Maximum measured error	Level	±0.4 mm (±0.016 in)	Reference condition Accuracy of NMi approved calibration rig at Endress +Hauser Yamanashi according to the combination of the order code is as per the table below.
	Interface	±2 mm (±0.08 in)	Reference condition <ul style="list-style-type: none"> Standard displacer 70 mm (2.76 in) Density difference 0.2 g/cm₃ or more (min. detectable density difference for interface measurement is 0.1 g/cm₃) Max. performance selected in feat.150
	Tank bottom	±2 mm (±0.08 in)	Reference condition <ul style="list-style-type: none"> Standard displacer 70 mm (2.76 in) Flat datum plate or flat tank bottom Max. performance selected in feat.150
	Density	±0.003 g/cm ³	Reference condition <ul style="list-style-type: none"> Standard displacer 50 mm (1.97 in) or 70 mm (2.76 in) On-site density calibration (offset) Max. performance selected in feat.150

The following values are valid for a level measurement distance up to 40 m (133.33 ft).

Ordering feature 150	Weight and measure approval	Displacer (ordering feature 120)			
		1AA, 2AA	1AC, 2AC, 3AC, 4AC, 5AC	1BE, 4AE	1BJ
		Ø30 mm (1.18 in)	Ø50 mm (1.97 in)	Ø70 mm (2.76 in)	Ø110 mm (4.33 in)
Accuracy					
ICR	Standard version, w/o calibration certificate	±2.5 mm (±0.1 in)	±1 mm (±0.04 in)	±1 mm (±0.04 in)	±1 mm (±0.04 in)
ICW	Standard version, 3-point calibration certificate	±2.5 mm (±0.1 in)	±1 mm (±0.04 in)	±1 mm (±0.04 in)	±1 mm (±0.04 in)
ICX	Standard version, 5-point calibration certificate	±2.5 mm (±0.1 in)	±1 mm (±0.04 in)	±1 mm (±0.04 in)	±1 mm (±0.04 in)
NTA	Maximum performance, NMi type approval acc. OIML R85, API 3.1B, ISO 4622, factory calibration certificate	N/A	±0.6 mm (±0.024 in)	±0.4 mm (±0.016 in)	±0.4 mm (±0.016 in)
NTC	Custody transfer type approval acc. NMi OIML R85, API 3.1B, ISO4622, factory calibration certificate	N/A	±1 mm (±0.04 in)	±1 mm (±0.04 in)	±1 mm (±0.04 in)

Ordering feature 150	Weight and measure approval	Displacer (ordering feature 120)			
		1AA, 2AA	1AC, 2AC, 3AC, 4AC, 5AC	1BE, 4AE	1BJ
		Ø30 mm (1.18 in)	Ø50 mm (1.97 in)	Ø70 mm (2.76 in)	Ø110 mm (4.33 in)
Accuracy					
PTA	Maximum performance, PTB type approval factory calibration certificate	N/A	±0.6 mm (±0.024 in)	±0.4 mm (±0.016 in)	±0.4 mm (±0.016 in)
PTC	Custody transfer type approval per PTB, factory calibration certificate	N/A	±1 mm (±0.04 in)	±1 mm (±0.04 in)	±1 mm (±0.04 in)

Hysteresis Within the specified accuracy (+/- 1 mm (0.039 in)) according to OIML R85 (2008)
It can be reduced by non hysteresis measurement mode.

Repeatability 0.1 mm (0.004 in)

Linearity Within maximum measured error

Long-term drift Within the specified error of measurement

Influence of ambient temperature Within the specified accuracy according to OIML R85 (2008)

Influence of medium temperature None (Displacer principle is not influenced by medium temperature.)

Influence of medium pressure No influence of medium pressure to the measuring principle.







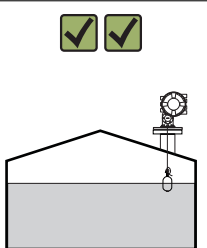
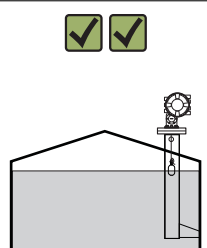
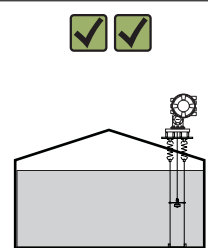

Effect of gas phase No effect of gas phase to the measuring principle.

Installation

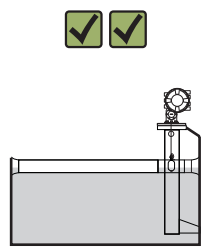
Requirements

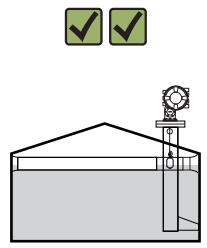
Type of tanks

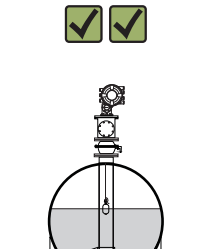
Depending on the type of tank and application, different installation procedures are recommended for NMS8x.

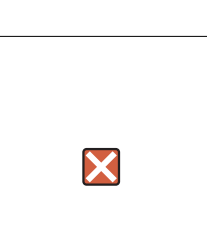
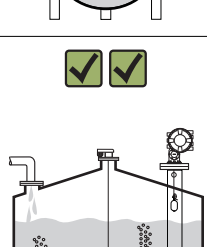
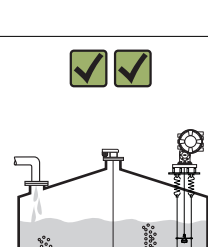
Type of tanks	Without guide system	With stilling well	With guide wires
Fixed roof tank			
Floating roof tank			
Covered floating roof tank			
Pressurized or bullet tank			
Tank with agitator or heavy turbulence			

-  A stilling well is required in a floating roof tank and a covered floating roof tank.
- Guide wires cannot be installed in a floating roof tank. When the measuring wire is exposed to free space, it may break due to an external shock.
- Installing guide wires is not allowed in pressurized tanks because the wires would prevent closing the valve for replacing the wire, wire drum, or displacer. NMS8x installation position is important for applications without the guide wire system in order to prevent the measuring wire from being broken (refer to Operating Instructions for details).

Mounting with a stilling well

The stilling well diameter that is required to protect the measuring wire without disturbing its operation varies depending on the tank height. The stilling well could either be of constant diameter, or narrower at its upper part and wider at its lower part. The following figure shows two examples of the latter case, namely a concentric stilling well and an asymmetric stilling well.

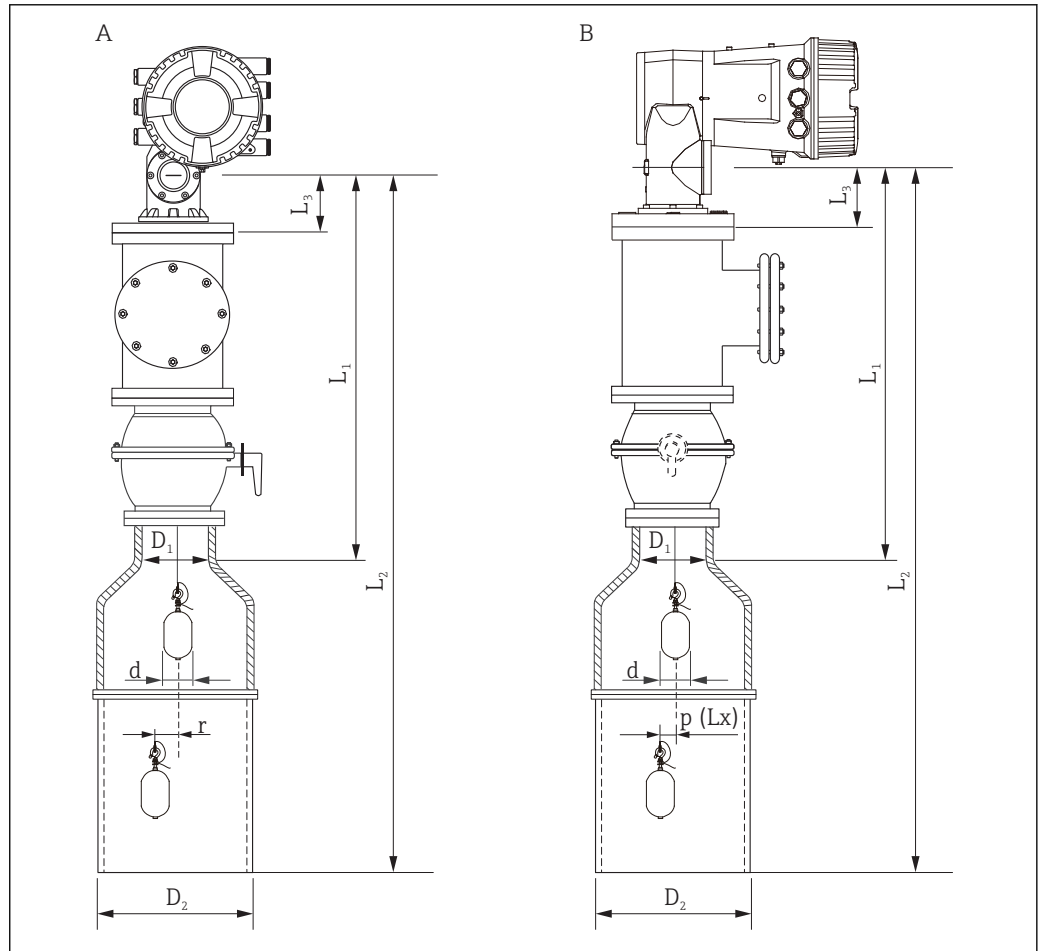

A0029577

12 Mounting with concentric stilling well

- A Front view
- B Side view
- L_1 Length from the center of the calibration window to the upper part of the stilling well
- L_2 Length from the center of the calibration window to the bottom of the stilling well
- L_3 Length from the center of the calibration window to the bottom of the flange
- D_1 Diameter of upper part of stilling well
- D_2 Diameter of stilling well
- d Diameter of displacer
- $p(Lx)$ Longitudinal wire position from the center of the flange
- r Radial direction offset

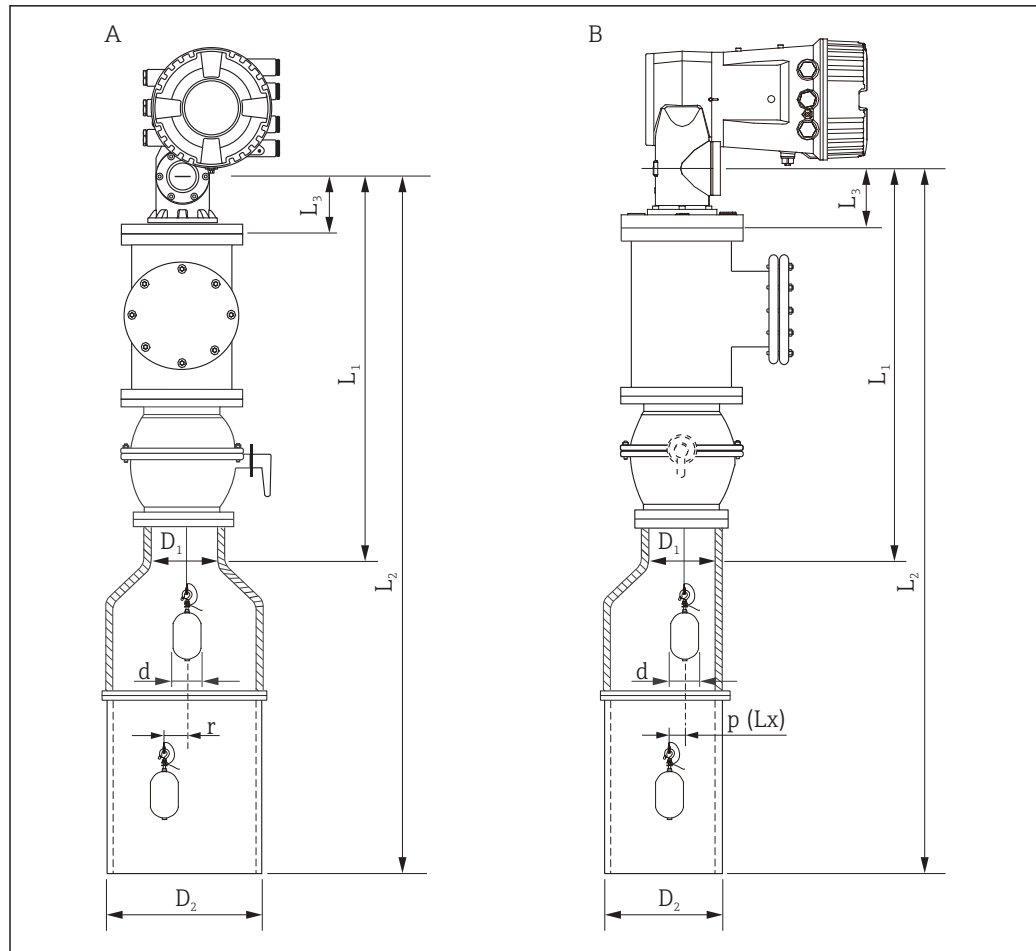

A0029576

13 Mounting with asymmetric stilling well

A Front view

B Side view

L_1 Length from the center of the calibration window to the upper part of the stilling well

L_2 Length from the center of the calibration window to the bottom of the stilling well

L_3 Length from the center of the calibration window to the bottom of the flange

D_1 Diameter of upper part of stilling well

D_2 Diameter of stilling well

d Diameter of displacer

p Longitudinal wire position from the center of the flange

(Lx)

r Radial direction offset

- i** L_3 : length from center of the calibration window to the bottom of the flange (77 mm (3.03 in) + flange thickness).
For JIS 10K 150A RF, the flange thickness is 22 mm (0.87 in).
- When using an asymmetric stilling well, take into account the lateral shift of the displacer and follow the NMS8x mounting direction as shown in the figure.
- To calculate the required stilling well diameters, the formula below should be used. The following tables contain the necessary parameters in order to calculate the dimensions of the stilling well. Be sure to have appropriate dimensions of the stilling well according to each dimension in the table.
- The radial direction offset (r) is required for only the 47 m (154.20 ft) and 55 m (180.45 ft) wire drum. For all other drums, the offset is 0 mm/in.

Feature: 110	Description (Measuring range; Wire; Diameter)	NMS80	NMS81	NMS83	r
G1	47 m (154.20 ft); 316L; 0.15 mm (0.00591 in)		☑		6 mm (0.24 in)
H1	55 m (180.45 ft); 316L 0.15 mm (0.00591 in)		☑		6 mm (0.24 in)

Feature: 120	Description (Displacer material; Type)	NMS80	NMS81	NMS83	d
1AA	316L; 30 mm (1.18 in) cylindrical	☑	☑		30 mm (1.18 in)
1AC	316L; 50 mm (1.97 in) cylindrical	☑	☑		50 mm (1.97 in)
1BE	316L; 70 mm (2.76 in) conical	☑	☑		70 mm (2.76 in)
1BJ	316L; 110 mm (4.33 in) conical	☑	☑		110 mm (4.33 in)
2AA	PTFE; 30 mm (1.18 in) cylindrical	☑	☑		30 mm (1.18 in)
2AC	PTFE; 50 mm (1.97 in) cylindrical	☑	☑		50 mm (1.97 in)
3AC	AlloyC276; 50 mm (1.97 in) cylindrical	☑	☑		50 mm (1.97 in)
4AC	316L polished; 50 mm (1.97 in) cylindrical			☑	50 mm (1.97 in)
4AE	316L polished; 70 mm (2.76 in) conical			☑	70 mm (2.76 in)
5AC	PTFE; 50 mm (1.97 in) cylindrical, hygienic white			☑	50 mm (1.97 in)

Parameter	Description
d	Diameter of displacer
p(Lx)	Longitudinal wire position from the center of the flange The value can be determined by using following graph.
r	Radial direction offset
s	Safety factor recommended: 5 mm (0.197 in)

The following graph shows the lateral shift of the displacer depending on the measured distance for the different wire drums.

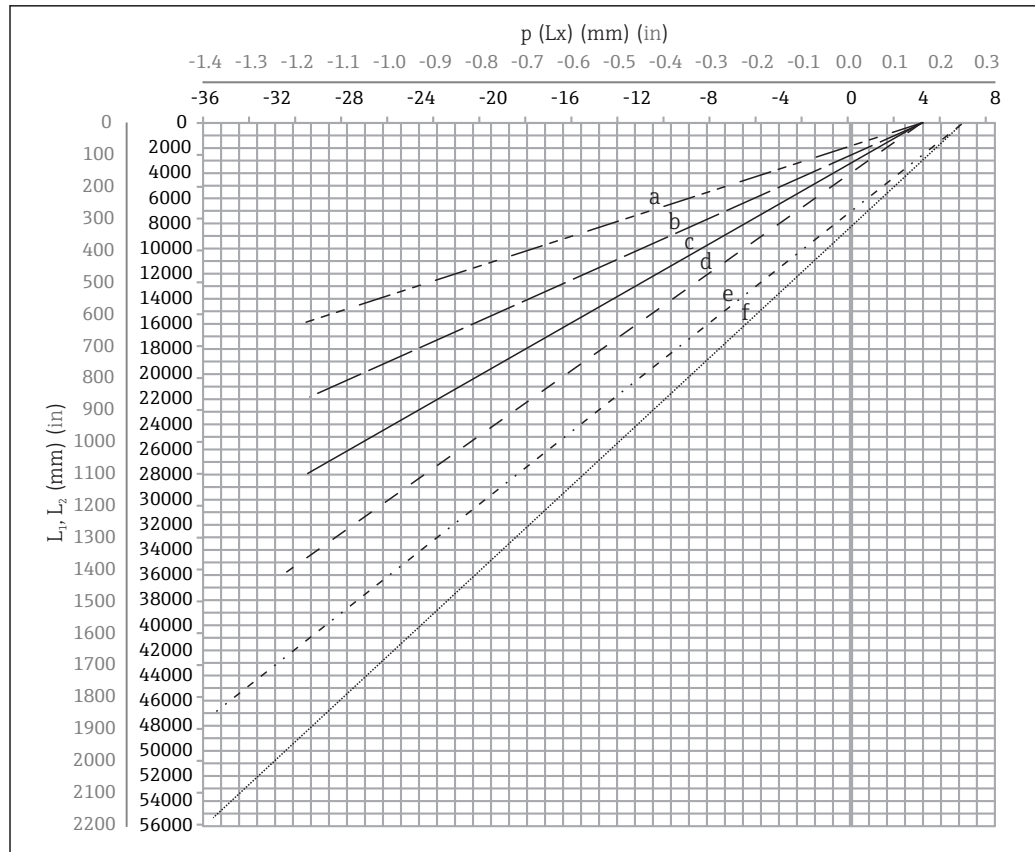

A0027997

14 Lateral shift of displacer according to measurement range

- a 16 m (A3) (NMS80/NMS81/NMS83)
- b 22 m (C2) (NMS80/NMS81/NMS83)
- c 28 m (D1) (NMS80/NMS81)
- d 36 m (F1) (NMS80/NMS81)
- e 47 m (G1) (NMS81)
- f 55 m (H1) (NMS81)

Upper diameter of stilling well

The dimension of D_1 has to be the largest value of the dimensions D_{1a} , D_{1b} , D_{1c} , and D_{1d} according to the following formula.

D ₁ Dimension (Example)	D _{1x} Dimension		Description	Formula
	Example	Parameter		
>68.1 mm (2.68 in)	68.1 mm (2.68 in)	D _{1a}	D ₁ dimension when the displacer is at the center of the calibration window	$= 2 \times (p(0) + d/2 + s)$
	65.6 mm (2.58 in)	D _{1b}	D ₁ dimension when the displacer is at the upper part of the stilling well	$= 2 \times (p(L_1) + d/2 + s)$

D ₁ Dimension (Example)	D _{1x} Dimension		Description	Formula
	Example	Parameter		
	50.9 mm (2.00 in)	D _{1c}	D ₁ dimension when the displacer is at the bottom of the stilling well	$= 2 \times (p (L_2) + s)$
		D _{1d}	D ₁ dimension when the radial direction offset is considered. This calculation is used only with the 47 m (154.20 ft) wire drum (G1 in Feature110) and 55 m (180.45 ft) (H1 in feature 110)	$= 2 \times (d/2 + r + s)$

 Example: L₁ = 1 000 mm, L₂ = 20 000 mm, d = 50 mm, s = 5.0, 28 m drum

Lower diameter of stilling well

The dimension of D₂ has to be the larger value of the dimensions D₁ and D_{2b}.

See the table below.

Concentric pipe

D ₂ Dimension (Example)	D _{2x} Dimension		Description	Formula
	Example	Parameter		
>100.9 mm (3.97 in)	68.1 mm (2.68 in)	D ₁	Calculated D ₁ value	
	100.9 mm (3.97 in)	D _{2b}	D ₂ dimension when the displacer is in L ₂ length	$= 2 \times (p (L_2) + d/2 + s)$

 Example: L₂ = 20 000 mm, d = 50 mm, s = 5.0, 28 m drum

Asymmetric pipe

D ₂ Dimension (Example)	D _{2x} Dimension		Description	Formula
	Example	Parameter		
>84.5 mm (3.33 in)	68.1 mm (2.68 in)	D ₁	Calculated D ₁ value	
	84.5 mm (3.33 in)	D _{2b}	D ₂ dimension that the displacer can pass through (nth groove)	$= p (L_2) + d/2 + s + D_1/2$

 Example: L₂ = 20 000 mm, d = 50 mm, s = 5.0, 28 m drum

Recommendations for NMS8x mounting with a stilling well

 Follow the recommendations for mounting NMS8x with a stilling well.

- Keep the pipe connection welds smooth.
- When drilling holes into the pipe, keep the interior surface of the holes clear of metal chips and burrs.
- Coat or paint the interior surface of the pipe to prevent corrosion.
- Keep the pipe as vertical as possible. Check using a plumb bob.
- Install the asymmetric pipe under the valve and align the centers of the NMS8x and the valve.
- Set the center of the lower part of the asymmetric pipe in the direction of the lateral motion.
- Observe the recommendations as per API MPMS chapter 3.1B.
- Confirm grounding between NMS8x and the tank nozzle.

Mounting with guide wires

It is also possible to guide the displacer with guide wires to prevent swinging.

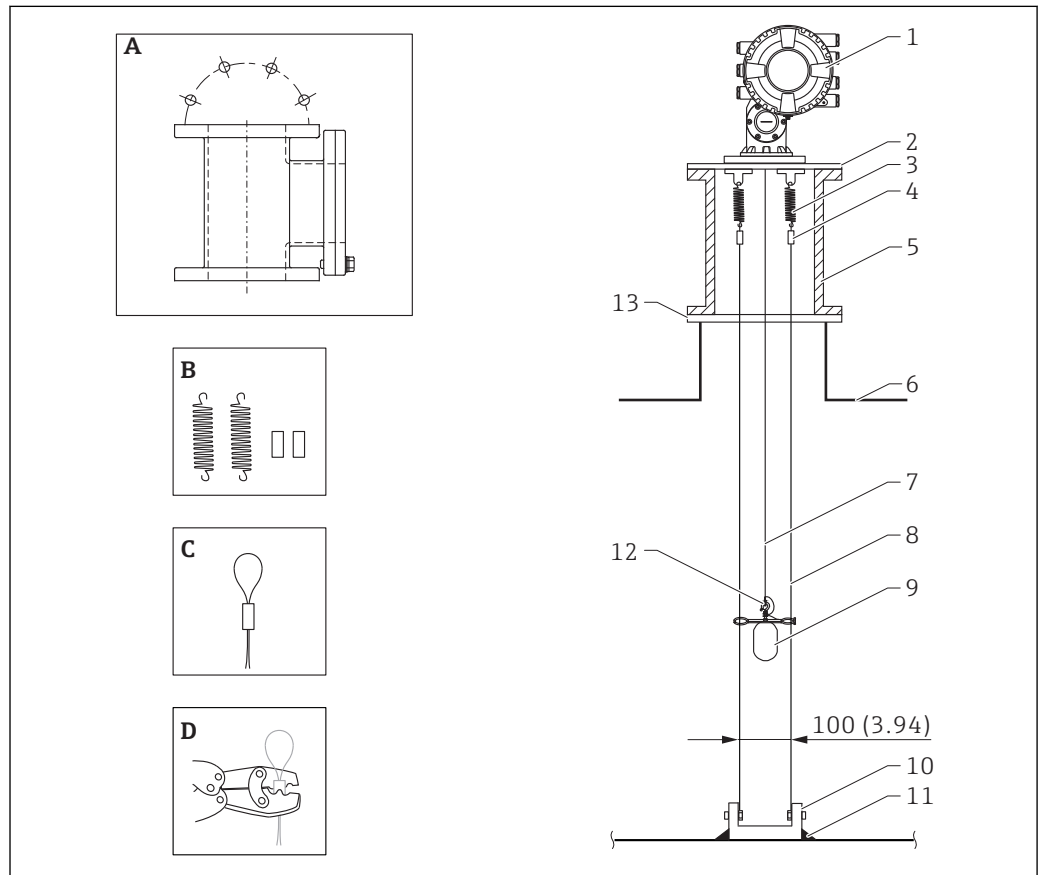

A0026819

15 Guide wire; dimensions mm (in)

No.	Description
A	Calibration chamber
B	Spring and sleeve
C	Guide wire sleeve
D	Crimp tool
1	NMS8x
2	Reducer plate
3	Spring, SUS304
4	Sleeve, SUS316
5	Calibration chamber for maintenance
6	Tank
7	Measuring wire
8	Guide wire, SUS316
9	Displacer
10	Anchor hook plate, SUS304
11	Welding point
12	Wire ring, SUS316L
13	Flange

Environment

Ambient temperature range	Device	-40 to +60 °C (-40 to +140 °F)
	Display module	-20 to +70 °C (-4 to +158 °F)  The readability of the display may be impaired at temperatures outside this temperature range.
Classification of environmental conditions according to DIN EN 60721-3-4	4K5, 4K6, 4B1, 4M7, 4Z2, 4Z3, 4Z8	
Storage temperature	-50 to +80 °C (-58 to +176 °F)	
Humidity	≤ 95 %	
Degree of protection	<ul style="list-style-type: none"> ▪ IP68/66 according to DIN EN 60529 ▪ Type 6P/4x according to NEMA 250 	
Electromagnetic compatibility (EMC)	<ul style="list-style-type: none"> ▪ Transient emissions according to DIN EN 61326, class B ▪ Interference resistance according to DIN EN 61326, Appendix A (Industry use) and NAMUR recommendation NE21 	

Process

Process temperature range -200 to +200 °C (-328 to 392 °F)

i If the specification of the tank application exceeds the range above, a special displacer can be ordered.

Process sealing

A1	HNBR	-30 to 150 °C (-22 to 302 °F)
B1	FKM, GLT	-40 to 150 °C (-40 to 302 °F)
C1	CR Chloropren	-30 to 80 °C (-22 to 176 °F)
D1	PTFE (Wire drum FKM)	-100 to 150 °C (-148 to 302 °F)
E1	VMQ silicone	-40 to 200 °C (-40 to 392 °F)

i A temperature difference exists between the liquid in the tank and the NMS8x on the tank nozzle due to the distance from each other. Also, the process temperature of NMS8x does not show the temperature for the liquid temperature. The process sealing temperature shows the temperature of the gas that reaches inside the housing of the NMS8x. In most cases, the gas temperature is the same as the ambient temperature. If there are any temperature differences between the process sealing and the gas, install a pipe or chamber between the NMS8x and the tank nozzle to adjust the temperature or cover the tank with a heat insulating material to control the temperature.

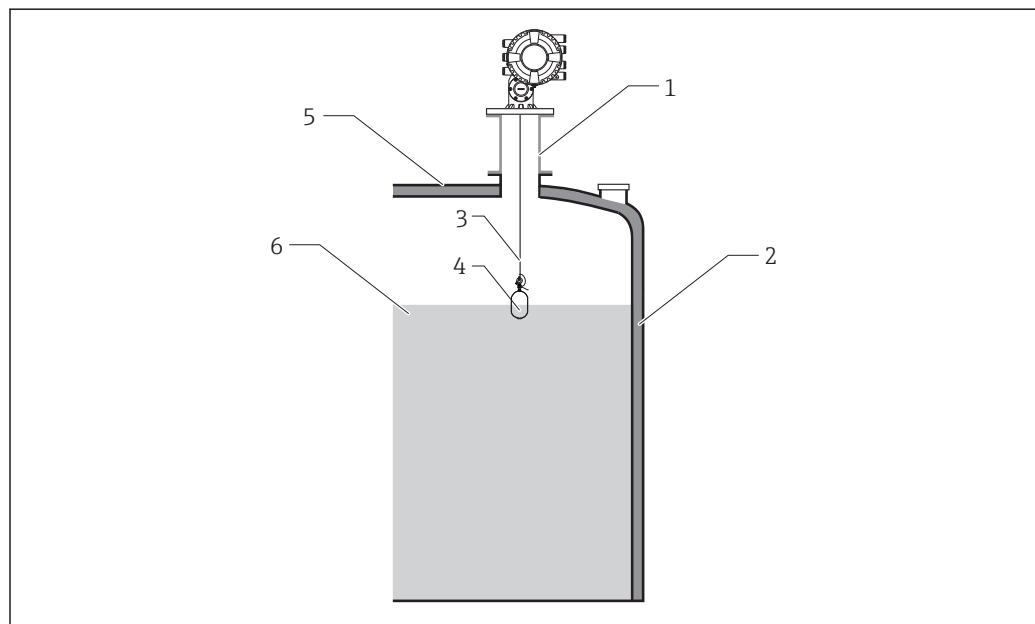

A0028848

i 16 Process sealing

- 1 Chamber or pipe for adjusting temperature
- 2 Heat insulating material
- 3 Measuring wire
- 4 Displacer
- 5 Tank wall
- 6 High or low temperature liquid

Process pressure range

Housing type	Process pressure range
Aluminum	0 to 6 bar (600 Kpa/87 psi)

Medium density 0.430 to 2.000 g/cm³ (27 to 125 lb/ft³)

**Medium density difference
for interface measurement** 0.1 g/cm³ (6.24 lb/ft³)

Viscosity 0 to 5 000 mPa s

Custody transfer approval

Ordering feature 150 "Accuracy, Weight + Measure Approval" ¹⁾	Accuracy properties
ICR	Standard version (± 1 mm), without calibration certificate
ICW	Standard version (± 1 mm), 3-point calibration certificate
ICX	Standard version (± 1 mm), 5-point calibration certificate
LTA	Maximum performance (± 0.4 mm), type approval according to LNE, OIML R85, API 3.1B, ISO4622, factory calibration certificate
LTC	Custody transfer (± 1 mm) type approval according to NMI, OIML R85, API 3.1B, ISO4622, factory calibration certificate
NTA	Maximum performance (± 0.4 mm), type approval according to NMI, OIML R85, API 3.1B, ISO4622, factory calibration certificate
NTC	Custody transfer (± 1 mm) type approval according to NMI, OIML R85, API 3.1B, ISO4622, factory calibration certificate
PTA	Maximum performance (± 0.4 mm), PTB type approval, factory calibration certificate
PTC	Custody transfer (± 1 mm) type approval per PTB, factory calibration certificate

1) Position 25 to 27 in the order code (e.g. NMS8x-xxxxxxxxxxxxxxxxxxxxxxxxxICR...)



- Depending on the displacer (ordering feature 120) some of these versions will not be available.
- Proservo NMS8x that are certified for Custody Transfer applications are calibrated on a certified production rig. The production rig reference standard is a laser tracker with an absolute accuracy of ± 0.010 mm and a resolution of 0.0002 mm. Calibration is performed at 10 equally-spaced measuring points over the full measuring range (up to 40 m (131 ft)). Additionally, hysteresis is checked at three points.
- The Maximum Permissible Error (MPE) is 0.4 mm (0.016 in) for maximum performance models, and ± 1 mm (± 0.04 in) for custody transfer models. The resultant factory calibration certificate is included in the scope of delivery along with the respective type approval certificate.

Mechanical construction

Dimensions

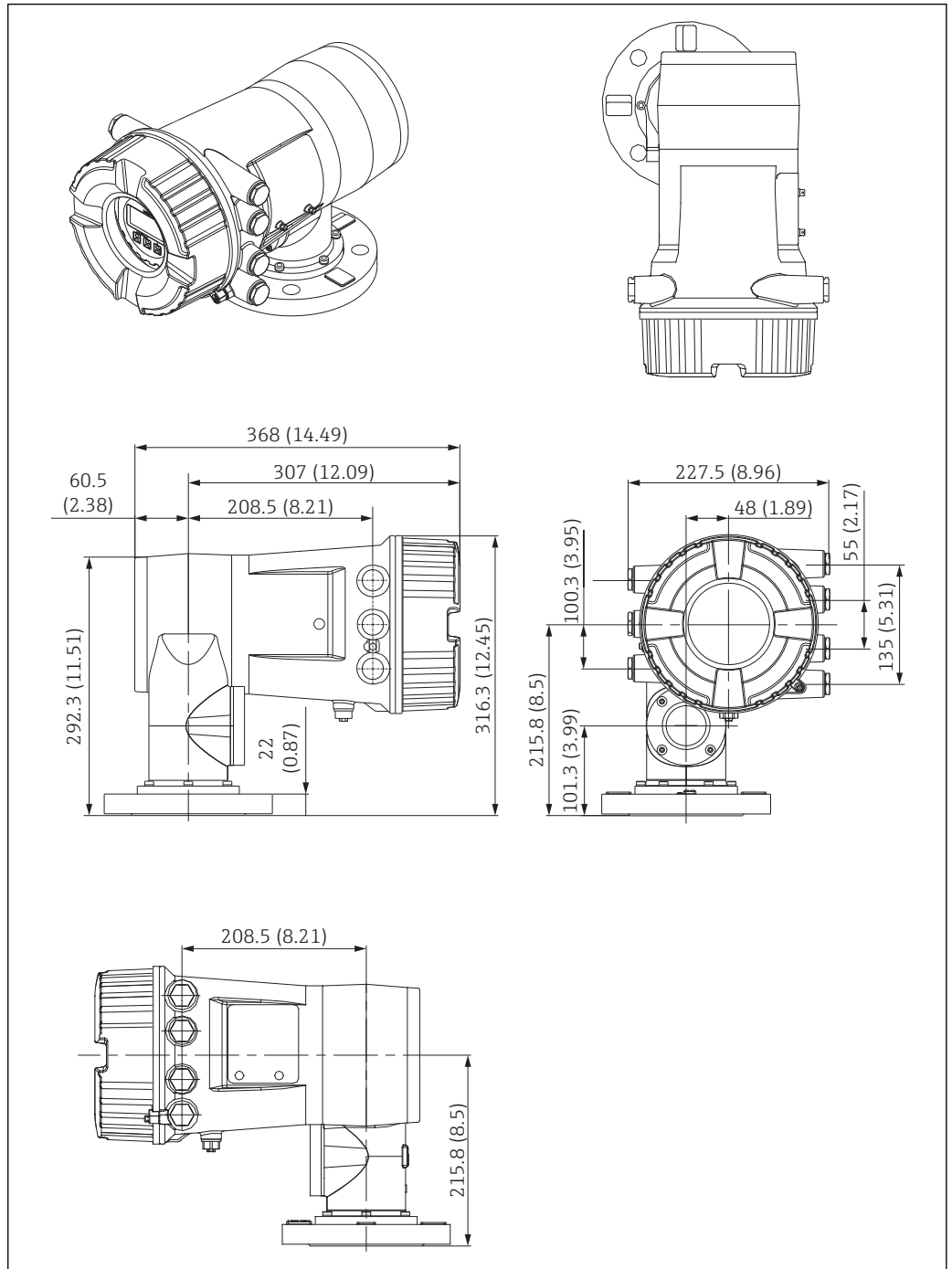

A0029578

i The thickness of the flange (22 mm (0.87 in)) shows the specification of the 10K 150A RF aluminium flange JIS B2220.

Weight

- Approx. 15 kg (33.0 lb) with NPS 3" Cl. 150, DN80PN10/16, 10K80A flange
- Approx. 20 kg (44.1 lb) with NPS 6" Cl. 150 flange
- Approx. 24 kg (52.9 lb) with NPS 8" Cl. 150 flange

i The weights vary depending on the selected options.

Materials

Material of housing

Feature	Option	Housing descriptions
070	AB	Transmitter + process Alu, coated

Materials of measuring wire

Feature	Option	Wire descriptions
110	A3	16 m (53.33 ft); PFA >316L; 0.4 mm (0.016 in)
110	C2	22 m (73.33 ft); AlloyC276; 0.2 mm (0.008 in)
110	D1	28 m (93.33 ft); 316L; 0.15 mm (0.006 in)
110	F1	36 m (120 ft); 316L; 0.15 mm (0.006 in)
110	G1	47 m (154.20 ft); 316L; 0.15 mm (0.006 in)

Material of process connection (flange)

Feature	Option	Descriptions of process connection (flange)
140	AFA	NPS 3" Cl.150 RF, Aluminium flange ASME B16.5
140	AHA	NPS 6" Cl.150 RF, Aluminium flange ASME B16.5
140	GSA	DN80 PN10/16 B1, Aluminium flange EN1092-1
140	PFA	10K 80A RF, Aluminium flange JIS B2220
140	PHA	10K 150A RF, Aluminium flange JIS B2220
140	P5A	10K 80A FF, Aluminium flange JIS B2220
140	QFA	80A 150lbs RF, Aluminium flange JPI 7S-15

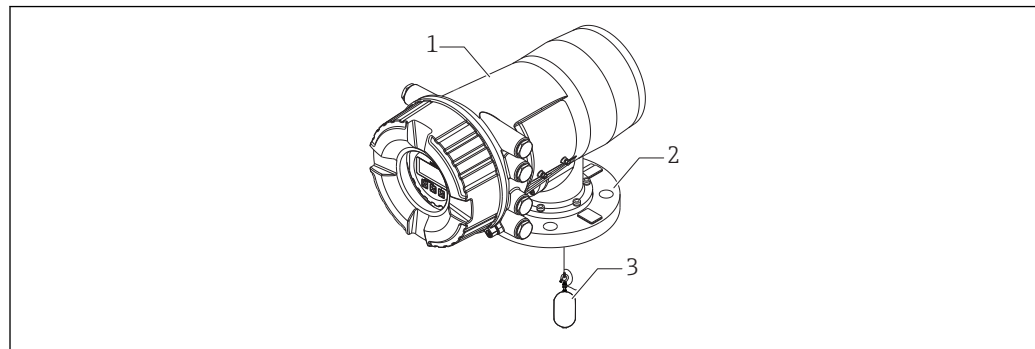

A0029583

- 1 Housing
- 2 Flange
- 3 Measuring wire

Operability

Operating concept

Operator-oriented menu structure for user-specific tasks

- Commissioning
- Operation
- Diagnostics
- Expert level

Operating languages

- English
- German
- Japanese

 Feature 500 of the product structure determines which of these languages is preset on delivery.

Quick and safe commissioning

- Guided menus ("Make-it-run" wizards) for applications
- Menu guidance with brief explanations of the individual parameter functions

Reliable operation

Standardized operation at the device and in the operating tools

Efficient diagnostics increase measurement reliability

- Remedy information is integrated in plain text
- Diverse simulation options

Operating options

- Local display; operation via the local display is possible without opening the device.
- Tank Gauging system
- Plant Asset Management tool (e.g. FieldCare); connected via
 - HART
 - Service port (CDI)

Local operation

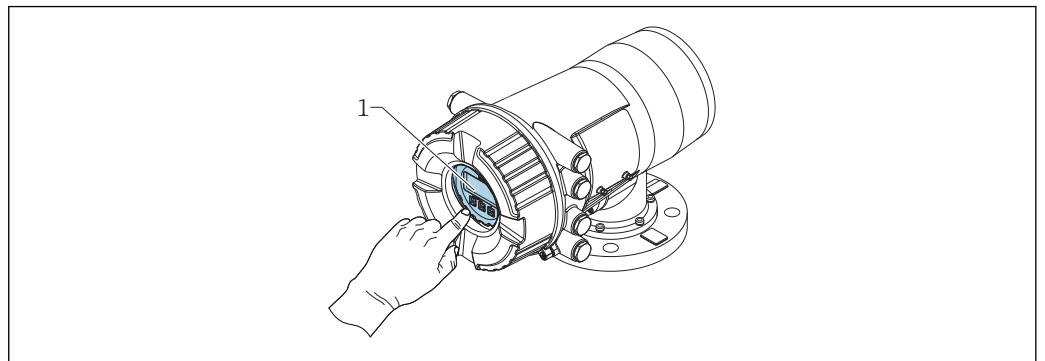



 17 NMS80 Display

1 Display

Display elements

- 4-line display
- White background lighting; switches to red in event of device errors
- Format for displaying measured variables and status variables can be individually configured
- Permitted ambient temperature for the display: -20 to $+70$ °C (-4 to $+158$ °F)
The readability of the display may be impaired at temperatures outside the temperature range.

Operating elements

- External operation via touch control; 3 optical keys: , , 
- Operating elements also accessible in various hazardous areas

Remote operation

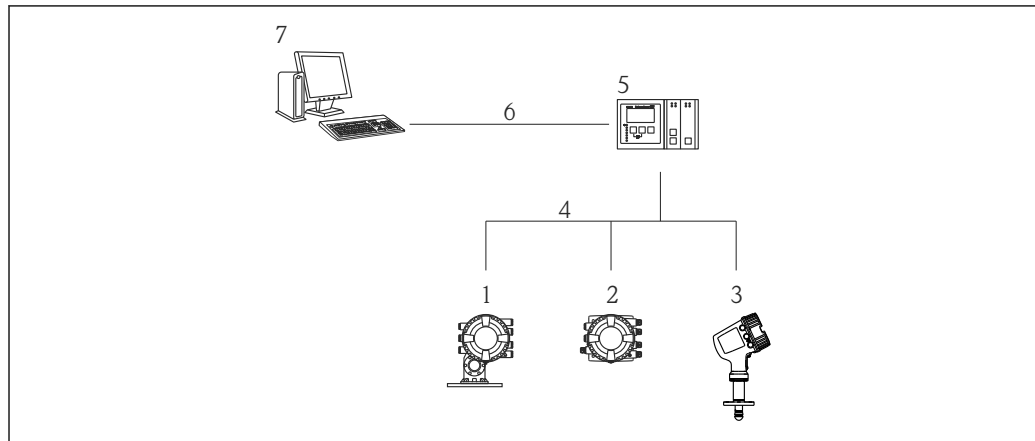

A0025621

18 Remote operation of Tank Gauging devices

- 1 Proservo NMS8x
- 2 Tankside Monitor NRF81
- 3 Micropilot NMR8x
- 4 Field protocol (e.g. Modbus, V1)
- 5 Tankvision Tank Scanner NXA820
- 6 Ethernet
- 7 Computer with operating tool (e.g. FieldCare)

Operation via service interface

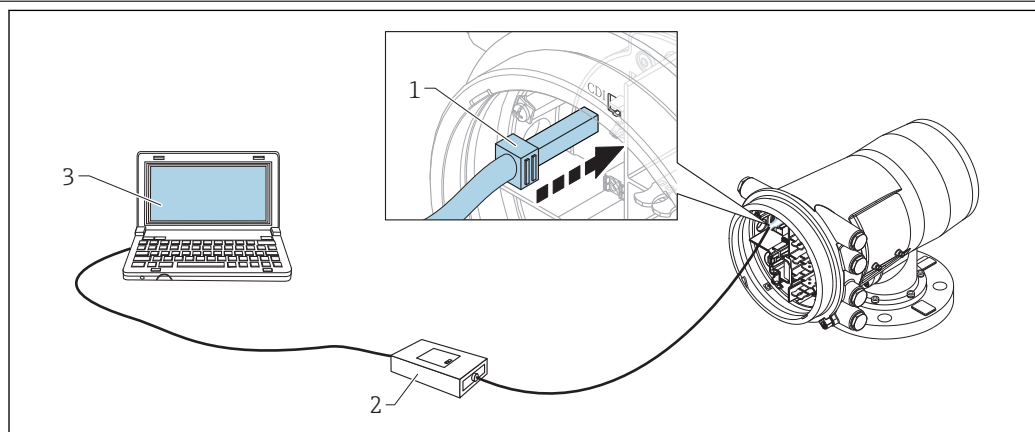

A0030161

19 Operation via service interface

- 1 Service interface (CDI = Endress+Hauser Common Data Interface)
- 2 Commubox FXA291
- 3 Computer with "FieldCare" operating tool and "CDI Communication FXA291" COM DTM

Certificates and approvals

 Currently available certificates and approvals can be called up via the product configurator.

CE mark The measuring system meets the legal requirements of the applicable EC guidelines. These are listed in the corresponding EC Declaration of Conformity together with the standards applied.
Endress+Hauser confirms successful testing of the device by affixing to it the CE mark.

RCM-Tick marking The supplied product or measuring system meets the ACMA (Australian Communications and Media Authority) requirements for network integrity, interoperability, performance characteristics as well as health and safety regulations. Here, especially the regulatory arrangements for electromagnetic compatibility are met. The products are labelled with the RCM- Tick marking on the name plate.



A0029561

Ex approval The devices are certified for use in hazardous areas and the relevant safety instructions are provided in the separate "Safety Instructions" (XA) document. Reference is made to this document on the nameplate.

 The separate documentation "Safety Instructions" (XA) containing all the relevant explosion protection data is available from your Endress+Hauser Sales Center.

Single seal according to ANSI/ISA 12.27.01 The devices have been designed according to ANSI/ISA 12.27.01 as single seal devices, allowing the user to waive the use and save the cost of installing external secondary process seals in the conduit as required by the process sealing sections of ANSI/NFPA 70 (NEC) and CSA 22.1 (CEC) These instruments comply with the North-American installation practice and provide a very safe and cost-saving installation for pressurized applications with hazardous fluids.

Further information can be found in the Safety Instructions (XA) of the relevant devices.

Functional Safety (SIL) Use for level monitoring (MIN, MAX, range) up to SIL 2 according to IEC 61508:2010.

For details refer to the "Functional Safety Manual":
SD01920G (NMS80, NMS81, NMS83)

WHG in preparation

Weight & Measure approval

- OIML R85 (2008)
- NMI
- PTB
- PAC
- LNE
- WELMEC
- GOST (in preparation)

 The device has a sealable locking switch according to the Weight & Measure requirements. This switch locks all software parameters related to the measurement. The switching status is indicated on the display and via the communication protocol.

Non-ionizing radiation protection According to guideline 2004/40/EG-ICNIRP Guidelines EN50371

CRN approval Some device versions have a CRN approval. Devices are CRN approved if the following two conditions are met:

- The CRN approval is selected (Product structure: Feature 590 "Additional Approval", option LD "CRN")
- The device has a CRN approved process connection according to the following table:

Feature 140: Process Connection	Meaning
AFA	NPS 3" Cl.150 RF, aluminium flange ASME B16.5
AHA	NPS 6" Cl.150 RF, aluminium flange ASME B16.5
AJA	NPS 8" Cl.150 RF, aluminium flange ASME B16.5

-  Process connections without CRN approval are not included in this table.
- CRN approved devices are marked with the registration number OF18152.5C on the nameplate.

Test, certificate

Ordering feature 580 "Test, Certificate"	Designation
KE	Pressure test, internal procedure, inspection certificate
KS	Welding documentation, wetted/pressurized seams

Other standards and guidelines

Industry standards

- Directive 2002/95/EC: "Restriction of Hazardous Substances Directive" (RoHS)
- Directive 2004/22/EC: "Measuring Instruments Directive" (MID)
- IEC61508: "Functional Safety of Electrical/Electronic/Programmable Electronic Safety-related Systems" (SIL)
- NACE MR 0175, NACE MR 0103: "Sulfide stress cracking resistant metallic materials for oilfield equipment"
- API Recommended Practice 2350: "Overfill Protection for Storage Tanks in Petroleum Facilities"
- API MPMS: "Manual of Petroleum Measurement Standards"
- EN 1127: "Explosive atmospheres - Explosion prevention and protection"
- IEC 60079: "Equipment protection"
- EN 1092: "Flanges and their joints"
- EN 13463: "Non-electrical equipment for use in potentially explosive atmospheres"
- TIA-485-A: "Electrical Characteristics of Generators and Receivers for Use in Balanced Digital Multipoint Systems"
- IEC61511: "Functional safety - Safety instrumented systems for the process industry sector"
- IEEE 754: "Standard for Binary Floating-Point Arithmetic for microprocessor systems"
- ISO4266: "Petroleum and liquid petroleum products - measurement of level and temperature in storage tanks by automatic methods"
- ISO6578: "Refrigerated hydrocarbon liquids - Static measurement - Calculation procedure"
- ISO 11223: "Petroleum and liquid petroleum products - Determination of volume, density and mass of the contents of vertical cylindrical tanks by Hybrid Tank Measurement Systems"
- ISO15169: "Petroleum and liquid petroleum products - Direct static measurement - Measurement of content of vertical storage tanks by hydrostatic tank gauging"
- JIS K2250: "Petroleum Measurement Tables"
- JIS B 8273: "Bolted flange for pressure vessels"
- G.I.I.G.N.L.: "LNG Custody transfer handbook"
- NAMUR NE043: "Standardization of the Signal Level for the Failure Information of Digital Transmitters"
- NAMUR NE107: "Self-Monitoring and Diagnosis of Field Devices"
- PTBA-A-4.2: "Volume measuring devices for liquids in a stationary condition - Storage containers and their measuring devices"

Metrological standards

- OIML R85 (2008) "Requirements for ambient temperature low -25 °C (-13 °F) and ambient temperature high +55 °C (+131 °F)
- "Mess- und Eichverordnung" (Calibration regulations for the Federal Republic of Germany)
- Directive 2004/22/EC of the European Parliament and of the Council of 31 March 2004 on measuring instruments

Ordering information

Ordering information

Detailed ordering information is available from the following sources:

- In the Product Configurator on the Endress+Hauser website: www.endress.com -> Click "Corporate" -> Select your country -> Click "Products" -> Select the product using the filters and search field -> Open product page -> The "Configure" button to the right of the product image opens the Product Configurator.
- From your Endress+Hauser Sales Center: www.addresses.endress.com



Product Configurator - the tool for individual product configuration

- Up-to-the-minute configuration data
- Depending on the device: Direct input of measuring point-specific information such as measuring range or operating language
- Automatic verification of exclusion criteria
- Automatic creation of the order code and its breakdown in PDF or Excel output format
- Ability to order directly in the Endress+Hauser Online Shop

Marking

Option of ordering feature 895 "Marking"	Meaning
Z1	Tagging (TAG)
Z2	Bus address

Optionally, the device can be ordered with a specific tagging and/or bus address according to the table above. When the respective option is selected, the tag or bus address must be defined in an additional specification.

Shipping condition

To enable turnkey operation and commission, NMS8x is shipped in all-in-one condition except for the following specifications.

- 47 m (154.20 ft) measuring range
- 55 m (180.45 ft) measuring range
- 110 mm (4.33 in) displacer
- NPS8 in flange
- Cleaned from oil+grease option

Application packages

Advanced tank measurement methods

The device software provides the following tank measurement methods:

- Direct level measurement → 48
- Hybrid tank measurement system (HTMS) → 49
- Hydrostatic tank shell correction (HyTD) → 50
- Thermal tank shell correction (CTSh) → 50

Direct level measurement

If no advanced tank measurement methods have been selected, level and temperature are measured directly.

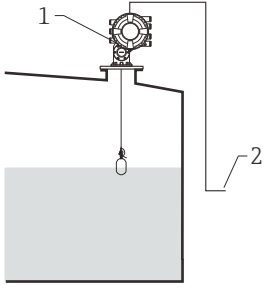
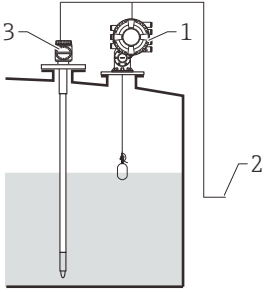

Direct level measurement modes

Measuring mode	Installation example	Measured variables	Calculated variables
Level only	 <p>1 NMS8x 2 To inventory management system</p>	Level	None
Level + temperature	 <p>1 NMS8x 2 To inventory management system 3 Temperature transmitter (point or average)</p>	<ul style="list-style-type: none"> ▪ Level ▪ Temperature (point or average) 	None

Hybrid tank measurement system (HTMS)

HTMS uses level and pressure measurements to calculate the contents of the tank and (optionally) the density of the medium.

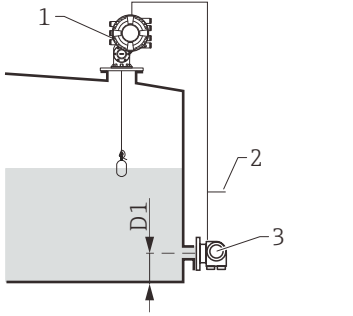
HTMS measuring modes

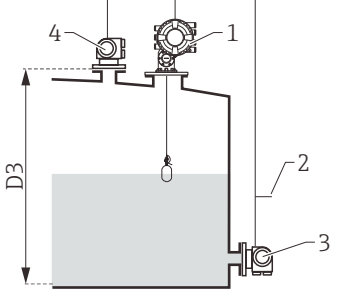
Measuring mode	Installation example	Measured variables	Calculated variables
<p>HTMS + P1</p> <p> This mode should be used in atmospheric (i.e. non-pressurized) tanks</p>	 <p style="text-align: right; font-size: small;">A0026830</p> <p>1 NMS8x 2 To inventory management system 3 Pressure transmitter (bottom)</p>	<ul style="list-style-type: none"> ■ Level ■ Bottom pressure (at position D1) 	<p>Density of the medium</p>
<p>HTMS + P1 + P3</p> <p> This mode should be used in non- atmospheric (i.e. pressurized) tanks</p>	 <p style="text-align: right; font-size: small;">A0026831</p> <p>1 NMS8x 2 To inventory management system 3 Pressure transmitter (bottom) 4 Pressure transmitter (top)</p>	<ul style="list-style-type: none"> ■ Level ■ Bottom pressure (at position D1) ■ Top pressure (at position D3) 	<p>Density of the medium</p>

Hydrostatic tank shell correction (HyTD)

The hydrostatic tank shell correction can be used to compensate for vertical movement of the Gauge Reference Height due to bulging of the tank shell caused by the hydrostatic pressure exerted by the liquid stored in the tank. The compensation is based on a linear approximation obtained from manual hand dips at several levels distributed over the full range of the tank.

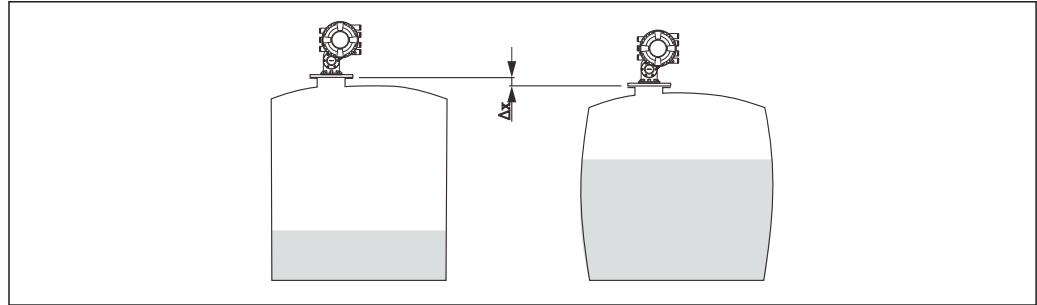

A0026832

20 Movement Δx of the tank reference height due to the bulging of the tank shell caused by hydrostatic pressure

Thermal tank shell correction (CTSh)

The thermal tank shell correction can be used to compensate for vertical movement of the Gauge Reference Height due to temperature effects on the tank shell or stilling well. The calculation is based on the thermal expansion coefficients of steel and on insulation factors for both the dry and wetted part of the tank shell.

- i** ■ This correction is recommended for any tank gauge operating at conditions deviating considerably from the conditions during calibration and for extremely high tanks. For refrigerated, cryogenic and heated applications this correction is highly recommended.
- Wire length can also be corrected with the parameters related to CTSh.

Accessories

Device-specific accessories

Weather protection cover

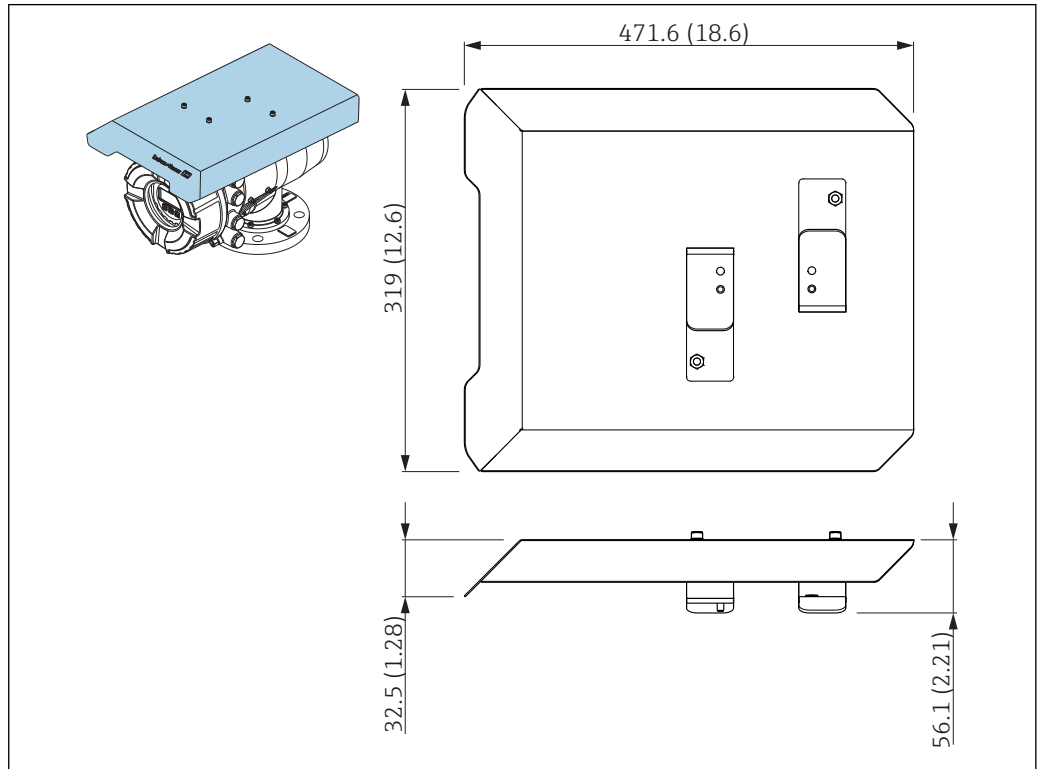

21 Weather protection cover; dimensions: mm (in)

Materials

Part	Material
Protection cover and mounting brackets	316L (1.4404)
Screws and washers	A4

- i
 - The weather protection cover can be ordered together with the device:
Ordering feature 620 "Accessory Enclosed", option PA "Weather Protection Cover")
 - It can also be ordered as an accessory:
Order code: 71305035 (for NMS8x)

Calibration chamber

A calibration chamber is recommended for use with tank level gauges in order to allow maintenance (removing the 70 mm (2.76 in) displacer or larger), while the tank is in service. Contact your Endress+Hauser Sales Center if necessary.

Ball valve

Ball valves are recommended for use with tank level gauges in order to allow maintenance such as removing displacers while tank is in service. Contact your Endress+Hauser Sales Center if necessary.

Control switch

A control switch is used for field mounted tank gauges. This provides additional gauge operation contact switching in order to control the gauge's operation, such as hoisting up the displacer. Contact your Endress+Hauser Sales Center if necessary.

Relief valve and pressure gauge

A relief valve is used to release pressure inside the housing of NMS8x before maintenance.

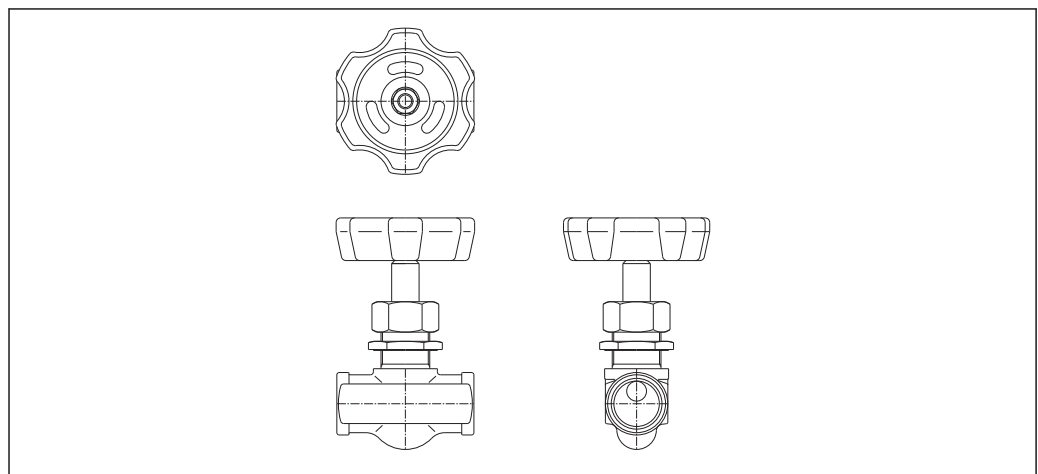

A0028881

 22 Relief valve

A pressure gauge is used to check process pressure inside the housing.

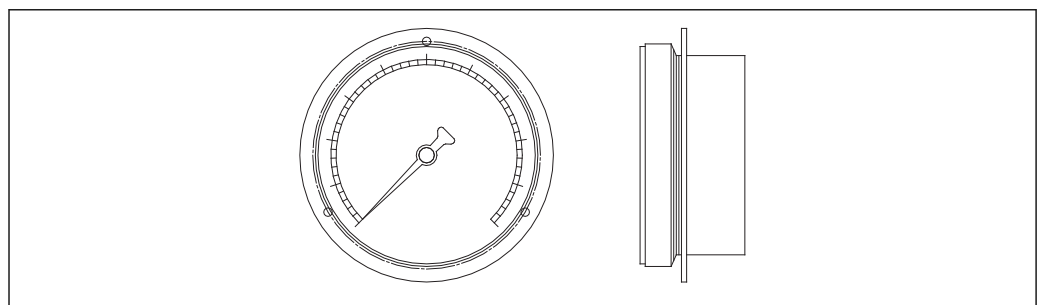

A0028882

 23 Pressure gauge

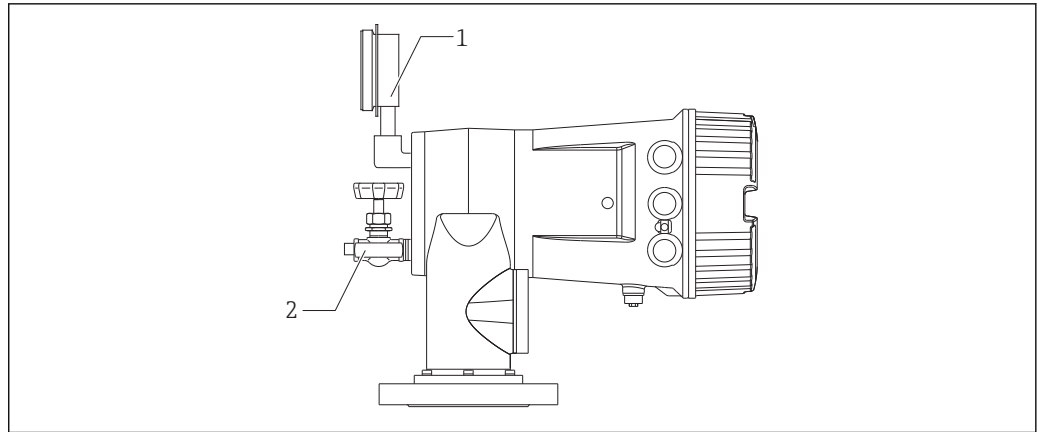

A0030102

24 Mounting position of relief valve and pressure gauge

- 1 Pressure gauge
- 2 Relief valve

Cleaning nozzle and gas purging nozzle

A cleaning nozzle used for washing inside housing is especially recommended for F&B or alcohol applications.

A gas purging nozzle used for purging gas inside the housing is especially recommended for a nitrogen blanket for petrochemical or chemical applications.

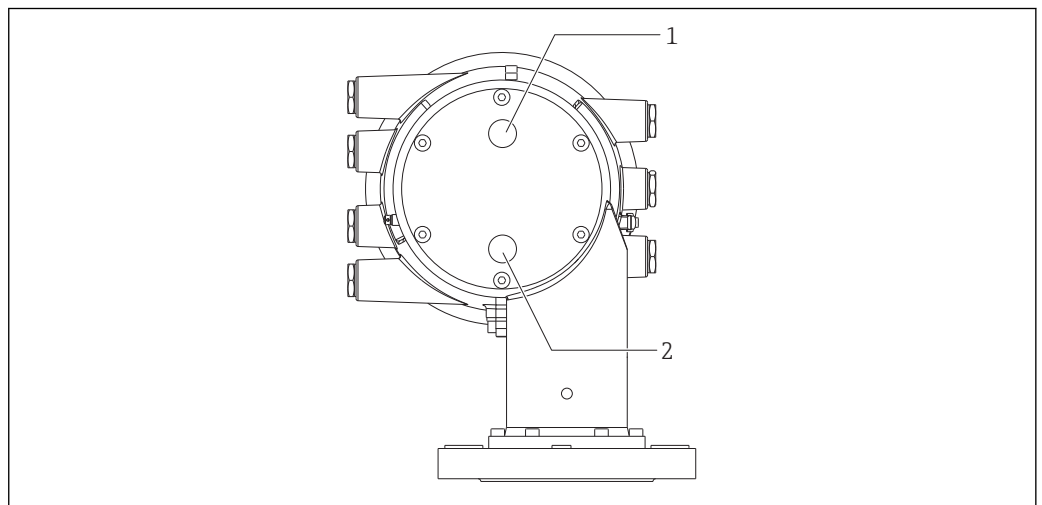

A0030103

25 Holes for cleaning nozzle and gas purging nozzle

- 1 Cleaning nozzle
- 2 Gas purging nozzle

Communication-specific accessories

Accessory	Description
WirelessHART Adapter SWA70	Connects field devices to a WirelessHART network. The WirelessHART adapter can be mounted directly at a HART device and is easily integrated into an existing HART network. It ensures safe data transmission and can be operated in parallel with other wireless networks.  For details refer to Operating Instructions BA00061S



Service-specific accessories

Accessory	Description
Commubox FXA195 HART	For intrinsically safe HART communication with FieldCare via the USB interface.  For details refer to Technical Information TI00404F

Accessory	Description
Commubox FXA291	Connects Endress+Hauser field devices with CDI interface (= Endress+Hauser Common Data Interface) to the USB interface of a computer.  For details refer to Technical Information TI00405C

Accessory	Description
FieldCare	Endress+Hauser's FDT-based Plant Asset Management tool. Helps to configure and maintain all field devices of your plant. By supplying status information it also supports the diagnosis of the devices.  For details refer to Operating Instructions BA00027S and BA00059S.

System components

Accessory	Description
RIA15	Compact process display unit with very low voltage drop for universal use to display 4 to 20 mA/HART signals  For details refer to Technical Information TI01043K.
Tankvision ▪ Tank Scanner NXA820 ▪ Data Concentrator NXA821 ▪ Host Link NXA822	Inventory Management System with completely integrated software for operation via standard web browser  For details refer to Technical Information TI00419G.

Documentation

Technical Information (TI) The Technical Information contains all the technical data on the device and provides an overview of the accessories and other products that can be ordered for the device.

Device	Technical Information
Proservo NMS80	TI01248G

Brief Operating Instructions (KA) The Brief Operating Instructions contain all the essential information from incoming acceptance to initial commissioning.

Device	Brief Operating Instructions
Proservo NMS80	KA01200G

Operating Instructions (BA) The Operating Instructions contain all the information that is required in various phases of the life cycle of the device: from product identification, incoming acceptance and storage, to mounting, connection, operation and commissioning through to troubleshooting, maintenance and disposal. It also contains a detailed explanation of each individual parameter in the operating menu (except the **Expert** menu). The description is aimed at those who work with the device over the entire life cycle and perform specific configurations.

Device	Operating Instructions
Proservo NMS80	BA01456G

Description of Device Parameters (GP) The Description of Device Parameters provides a detailed explanation of each individual parameter in the 2nd part of the operating menu: the **Expert** menu. It contains all the device parameters and allows direct access to the parameters by entering a specific code. The description is aimed at those who work with the device over the entire life cycle and perform specific configurations.

Device	Description of Device Parameters
Proservo NMS80	GP01074G

Safety instructions (XA)

Ordering feature 010 "Approval"	Meaning	XA
BC	ATEX II 1/2G Ex db [ia Ga] IIC T6 Ga/Gb	XA01495G
FD	FM C/US XP-AIS Cl.I Div.1 Gr.BCD T6 AEx db [ia Ga] IIC T6 Ga/Gb	XA01496G
GC	EAC Ga/Gb Ex db [ia Ga] IIC T6...T1 X	XA01711G
IC	IEC Ex db [ia Ga] IIC T6 Ga/Gb	XA01495G
KC ¹⁾	KC Ex d[ia] IIC T6 Ga/Gb	XA01495G
MC	INMETRO Ex d[ia] IIC T6 Ga/Gb	XA01705G
NC	NEPSI Ex d[ia] IIC T6 Ga/Gb	XA01704G
TC	TIIS Ex d[ia] IIC T4 Ga/Gb	XA01600G

1) KC approval is covered with IEC Ex approval.

Registered trademarks

FieldCare®

Registered trademark of the Endress+Hauser Process Solutions AG, Reinach, Switzerland

MODBUS®

Registered trademark of the MODBUS-IDA, Hopkinton, MA, USA



71411297

www.addresses.endress.com
