

# Operating Instructions

## Micropilot NMR84

### Tank Gauging

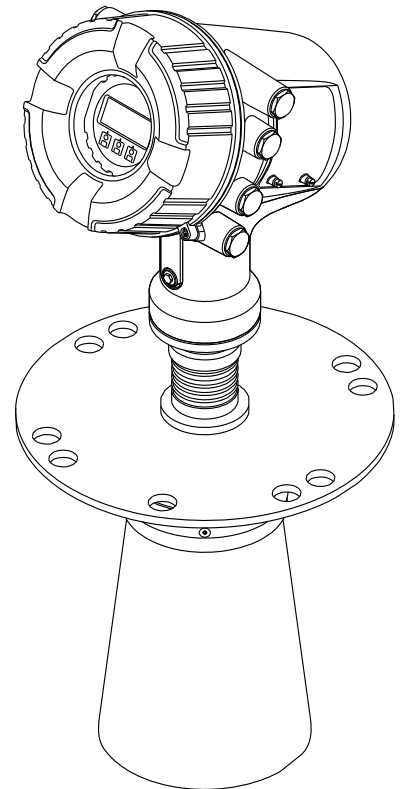

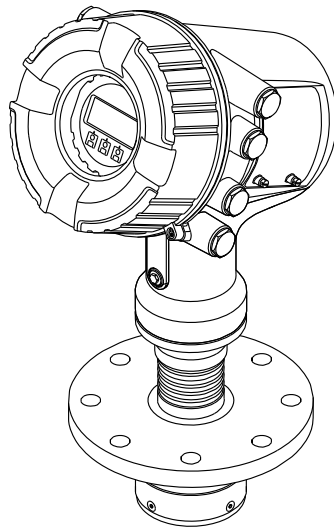
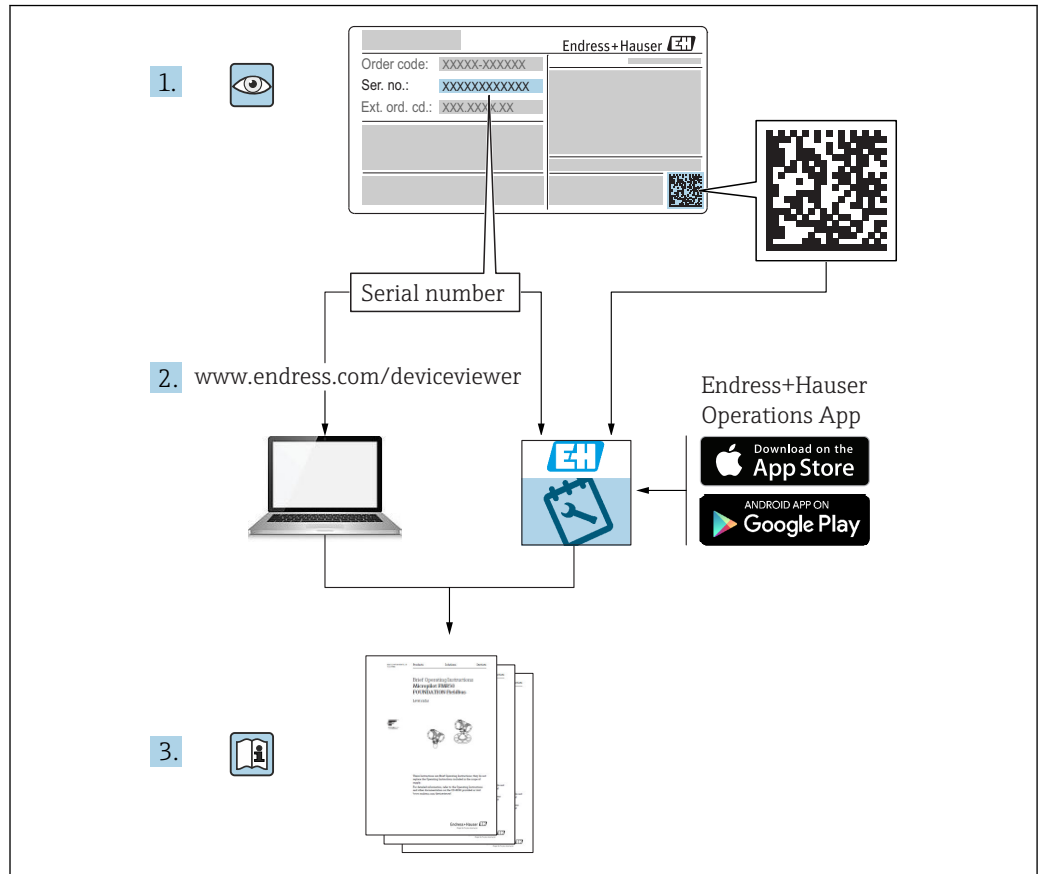

A0023555

## Table of contents

|          |  |           |                    |   |            |
|----------|--|-----------|--------------------|---|------------|
| <b>1</b> | <b>About this document</b> .....   | <b>4</b>  | 9.2                | Initial settings .....                                | 54         |
| 1.1      | Document function .....  | 4         | 9.3                | Configuring the measuring device .....                | 57         |
| 1.2      | Symbols .....  | 4         | 9.4                | Configuring the tank gauging application ....         | 59         |
| 1.3      | Documentation .....  | 7         | 9.5                | Advanced settings .....                               | 81         |
| 1.4      | Registered trademarks .....  | 9         | 9.6                | Simulation .....                                      | 81         |
| <b>2</b> | <b>Basic safety instructions</b> .....   | <b>10</b> | 9.7                | Protecting settings from unauthorized<br>access ..... | 81         |
| 2.1      | Requirements for the personnel .....   | 10        | <b>10</b>          | <b>Operation</b> .....                                | <b>82</b>  |
| 2.2      | Designated use .....   | 10        | 10.1               | Reading off the device locking status .....           | 82         |
| 2.3      | Workplace safety .....   | 11        | 10.2               | Reading off measured values .....                     | 82         |
| 2.4      | Operational safety .....   | 11        | <b>11</b>          | <b>Diagnostics and troubleshooting</b> ...            | <b>83</b>  |
| 2.5      | Product safety .....   | 11        | 11.1               | General trouble shooting .....                        | 83         |
| <b>3</b> | <b>Product description</b> .....   | <b>12</b> | 11.2               | Diagnostic information on local display .....         | 84         |
| 3.1      | Product design .....   | 12        | 11.3               | Diagnostic information in FieldCare .....             | 87         |
| <b>4</b> | <b>Incoming acceptance and product<br/>identification</b> .....                            | <b>13</b> | 11.4               | Overview of the diagnostic messages .....             | 89         |
| 4.1      | Incoming acceptance .....  | 13        | 11.5               | Diagnostic list .....                                 | 95         |
| 4.2      | Product identification .....   | 13        | 11.6               | Reset measuring device .....                          | 96         |
| 4.3      | Storage and transport .....  | 15        | 11.7               | Device information .....                              | 96         |
| <b>5</b> | <b>Installation</b> .....  | <b>16</b> | 11.8               | Firmware history .....                                | 96         |
| 5.1      | Installation conditions .....  | 16        | <b>12</b>          | <b>Maintenance</b> .....                              | <b>97</b>  |
| 5.2      | Post-installation check .....  | 17        | 12.1               | Maintenance tasks .....                               | 97         |
| <b>6</b> | <b>Electrical connection</b> .....   | <b>18</b> | 12.2               | Endress+Hauser services .....                         | 97         |
| 6.1      | Terminal assignment .....  | 18        | <b>13</b>          | <b>Repair</b> .....                                   | <b>98</b>  |
| 6.2      | Connecting requirements .....  | 33        | 13.1               | General information on repairs .....                  | 98         |
| 6.3      | Ensuring the degree of protection .....  | 34        | 13.2               | Spare parts .....                                     | 98         |
| 6.4      | Post-connection check .....  | 34        | 13.3               | Endress+Hauser services .....                         | 99         |
| <b>7</b> | <b>Operability</b> .....   | <b>35</b> | 13.4               | Return .....  | 99         |
| 7.1      | Overview of the operation options .....  | 35        | 13.5               | Disposal .....  | 99         |
| 7.2      | Structure and function of the operating<br>menu .....                                      | 36        | <b>14</b>          | <b>Accessories</b> .....                              | <b>100</b> |
| 7.3      | Access to the operating menu via the local or<br>remote display and operating module. .... | 37        | 14.1               | Device-specific accessories .....                     | 100        |
| 7.4      | Access to the operating menu via the service<br>interface and FieldCare .....              | 49        | 14.2               | Communication-specific accessories .....              | 101        |
| 7.5      | Access to the operating menu via Tankvision<br>Tank Scanner NXA820 and FieldCare .....     | 50        | 14.3               | Service-specific accessories .....                    | 101        |
| <b>8</b> | <b>System integration</b> .....  | <b>53</b> | 14.4               | System components .....                               | 101        |
| 8.1      | Overview of the Device Description files<br>(DTM) .....                                    | 53        | <b>15</b>          | <b>Operating menu</b> .....                           | <b>102</b> |
| <b>9</b> | <b>Commissioning</b> .....   | <b>54</b> | 15.1               | Overview of the operating menu .....                  | 102        |
| 9.1      | Terms related to tank measurement .....  | 54        | 15.2               | "Operation" menu .....                                | 111        |
|          |  |           | 15.3               | "Setup" menu .....                                    | 120        |
|          |  |           | 15.4               | "Diagnostics" menu .....                              | 236        |
|          |  |           | <b>Index</b> ..... | <b>248</b>  |            |





# 1 About this document

## 1.1 Document function







These Operating Instructions contain all the information that is required in various phases of the life cycle of the device: from product identification, incoming acceptance and storage, to mounting, connection, operation and commissioning through to troubleshooting, maintenance and disposal.

## 1.2 Symbols





### 1.2.1 Safety symbols

| Symbol  | Meaning  |
|---|--|
|    | <b>DANGER!</b><br>This symbol alerts you to a dangerous situation. Failure to avoid this situation will result in serious or fatal injury. |
|    | <b>WARNING!</b><br>This symbol alerts you to a dangerous situation. Failure to avoid this situation can result in serious or fatal injury. |
|   | <b>CAUTION!</b><br>This symbol alerts you to a dangerous situation. Failure to avoid this situation can result in minor or medium injury.  |
|  | <b>NOTE!</b><br>This symbol contains information on procedures and other facts which do not result in personal injury.                     |













### 1.2.2 Electrical symbols

| Symbol  | Meaning  |
|---|--|
|  | Direct current   |
|  | Alternating current  |
|  | Direct current and alternating current   |
|  | <b>Ground connection</b><br>A grounded terminal which, as far as the operator is concerned, is grounded via a grounding system.  |
|  | <b>Protective ground connection</b><br>A terminal which must be connected to ground prior to establishing any other connections.   |
|  | <b>Equipotential connection</b><br>A connection that has to be connected to the plant grounding system: This may be a potential equalization line or a star grounding system depending on national or company codes of practice. |

### 1.2.3 Tool symbols



| Symbol  | Meaning                |
|---|------------------------|
| <br>A0013442 | Torx screwdriver       |
| <br>A0011220 | Flat blade screwdriver |
| <br>A0011219 | Cross-head screwdriver |
| <br>A0011221 | Allen key              |
| <br>A0011222 | Hexagon wrench         |

### 1.2.4 Symbols for certain types of information



| Symbol  | Meaning  |
|---|--|
|    | <b>Permitted</b><br>Procedures, processes or actions that are permitted. |
|   | <b>Preferred</b><br>Procedures, processes or actions that are preferred. |
|  | <b>Forbidden</b><br>Procedures, processes or actions that are forbidden. |
|  | <b>Tip</b><br>Indicates additional information.                          |
|  | Reference to documentation   |
|  | Reference to page  |
|  | Reference to graphic   |
|  | Notice or individual step to be observed                                 |
|  | Series of steps  |
|  | Result of a step   |
|  | Help in the event of a problem   |
|  | Visual inspection  |

### 1.2.5 Symbols in graphics

| Symbol  | Meaning         |
|---|-----------------|
| 1, 2, 3 ...   | Item numbers    |
|  | Series of steps |
| A, B, C, ...  | Views           |
| A-A, B-B, C-C, ...  | Sections        |

| Symbol  | Meaning  |
|---|--|
|  | <b>Hazardous area</b><br>Indicates a hazardous area.                       |
|  | <b>Safe area (non-hazardous area)</b><br>Indicates the non-hazardous area. |

### 1.2.6 Symbols at the device

| Symbol  | Meaning   |
|---|---|
|  | <b>Safety instructions</b><br>Observe the safety instructions contained in the associated Operating Instructions.                             |
|  | <b>Temperature resistance of the connection cables</b><br>Specifies the minimum value of the temperature resistance of the connection cables. |

## 1.3 Documentation

 For an overview of the scope of the associated Technical Documentation, refer to the following:

- The *W@M Device Viewer* : Enter the serial number from the nameplate ([www.endress.com/deviceviewer](http://www.endress.com/deviceviewer))
- The *Endress+Hauser Operations App*: Enter the serial number from the nameplate or scan the 2-D matrix code (QR code) on the nameplate.

### 1.3.1 Technical Information (TI)

The Technical Information contains all the technical data on the device and provides an overview of the accessories and other products that can be ordered for the device.

| Device           | Technical Information |
|------------------|-----------------------|
| Micropilot NMR84 | TI01253G              |

### 1.3.2 Brief Operating Instructions (KA)

The Brief Operating Instructions contain all the essential information from incoming acceptance to initial commissioning.

| Device           | Brief Operating Instructions |
|------------------|------------------------------|
| Micropilot NMR84 | KA01197G                     |

### 1.3.3 Operating Instructions (BA)

The Operating Instructions contain all the information that is required in various phases of the life cycle of the device: from product identification, incoming acceptance and storage, to mounting, connection, operation and commissioning through to troubleshooting, maintenance and disposal.

It also contains a detailed explanation of each individual parameter in the operating menu (except the **Expert** menu). The description is aimed at those who work with the device over the entire life cycle and perform specific configurations.

| Device           | Operating Instructions |
|------------------|------------------------|
| Micropilot NMR84 | BA01453G               |

### 1.3.4 Description of Device Parameters (GP)

The Description of Device Parameters provides a detailed explanation of each individual parameter in the 2nd part of the operating menu: the **Expert** menu. It contains all the device parameters and allows direct access to the parameters by entering a specific code. The description is aimed at those who work with the device over the entire life cycle and perform specific configurations.

| Device           | Description of Device Parameters |
|------------------|----------------------------------|
| Micropilot NMR84 | GP01071G                         |

### 1.3.5 Safety instructions (XA)

| Ordering feature 010 "Approval" | Meaning  | XA             |
|---------------------------------|--|----------------|
| BC                              | ATEX II 1/2G Ex ia/db IIC T6 Ga/Gb<br>ATEX II 2 (1)G Ex db [ia Ga] IIC T6 Gb | XA01410G       |
| FC                              | FM C/US XP-AIS Cl.I Div.1 Gr.BCD T6<br>AEx d[ia] IIC T6                      | XA01436G       |
| GC                              | EAC Ga/Gb Ex ia/db IIC T6...T1 X<br>EAC 1 Ex db [ia] IIC T6...T1 X           | XA01582G       |
| IC                              | IEC Ex ia/db IIC T6 Ga/Gb<br>IEC Ex db [ia Ga] IIC T6 Gb                     | XA01410G       |
| KC                              | KC Ex d[ia] IIC T6 Ga/Gb<br>KC Ex db [ia Ga] IIC T6 Gb                       | XA01579G       |
| MC                              | INMETRO Ex ia/db IIC T6 Ga/Gb<br>INMETRO Ex db [ia Ga] IIC T6 Gb             | XA01580G       |
| NC                              | NEPSI Ex ia/db IIC T6 Ga/Gb<br>NEPSI Ex db [ia Ga] IIC T6 Gb                 | XA01581G       |
| TA                              | TIIS Ex d[ia] IIC T6 Ga/Gb   | in preparation |
| TC                              | TIIS Ex d[ia] IIC T4 Ga/Gb   | in preparation |
| TE                              | TIIS Ex d[ia] IIC T2 Ga/Gb   | in preparation |



## 1.4 Registered trademarks

### **FieldCare®**

Registered trademark of the Endress+Hauser Process Solutions AG, Reinach, Switzerland

### **MODBUS®**

Registered trademark of the MODBUS-IDA, Hopkinton, MA, USA

## 2 Basic safety instructions

### 2.1 Requirements for the personnel

The personnel for installation, commissioning, diagnostics and maintenance must fulfill the following requirements:

- ▶ Trained, qualified specialists must have a relevant qualification for this specific function and task.
- ▶ Are authorized by the plant owner/operator.
- ▶ Are familiar with federal/national regulations.
- ▶ Before starting work, read and understand the instructions in the manual and supplementary documentation as well as the certificates (depending on the application).
- ▶ Follow instructions and comply with basic conditions.

The operating personnel must fulfill the following requirements:

- ▶ Are instructed and authorized according to the requirements of the task by the facility's owner-operator.
- ▶ Follow the instructions in this manual.

### 2.2 Designated use

#### **Application and measured materials**

The measuring device described in these Operating Instructions is intended for the continuous, contact-less level measurement of liquids. The device must be installed in metallic stilling wells. Operation is completely harmless to humans and animals.

Depending on the version ordered, the measuring device can also measure potentially explosive, flammable, poisonous and oxidizing media.

Measuring devices for use in hazardous areas, in hygienic applications or in applications where there is an increased risk due to process pressure, are labeled accordingly on the nameplate.

To ensure that the measuring device remains in proper condition for the operation time:

- ▶ Only use the measuring device in full compliance with the data on the nameplate and the general conditions listed in the Operating Instructions and supplementary documentation.
- ▶ Check the nameplate to verify if the device ordered can be put to its intended use in the approval-related area (e.g. explosion protection, pressure vessel safety).
- ▶ Use the measuring device only for media against which the process-wetted materials are adequately resistant.
- ▶ If the measuring device is not operated at atmospheric temperature, compliance with the relevant basic conditions specified in the associated device documentation is absolutely essential.
- ▶ Protect the measuring device permanently against corrosion from environmental influences.
- ▶ Observe the limit values in the "Technical Information".

The manufacturer is not liable for damage caused by improper or non-designated use.

#### **Residual risk**

During operation the sensor may assume a temperature near the temperature of the measured material.

Danger of burns due to heated surfaces!

- ▶ For high process temperatures: Install protection against contact in order to prevent burns.

## 2.3 Workplace safety

For work on and with the device:

- ▶ Wear the required personal protective equipment according to federal/national regulations.

## 2.4 Operational safety

Risk of injury.

- ▶ Operate the device in proper technical condition and fail-safe condition only.
- ▶ The operator is responsible for interference-free operation of the device.

### Conversions to the device

Unauthorized modifications to the device are not permitted and can lead to unforeseeable dangers.

- ▶ If, despite this, modifications are required, consult with the manufacturer.

### Repair

To ensure continued operational safety and reliability,

- ▶ Carry out repairs on the device only if they are expressly permitted.
- ▶ Observe federal/national regulations pertaining to repair of an electrical device.
- ▶ Use original spare parts and accessories from the manufacturer only.

### Hazardous area

To eliminate a danger for persons or for the facility when the device is used in the hazardous area (e.g. explosion protection, pressure vessel safety):

- ▶ Based on the nameplate, check whether the ordered device is permitted for the intended use in the hazardous area.
- ▶ Observe the specifications in the separate supplementary documentation that is an integral part of these Instructions.

## 2.5 Product safety

This measuring device is designed in accordance with good engineering practice to meet state-of-the-art safety requirements, has been tested, and left the factory in a condition in which it is safe to operate. It meets general safety standards and legal requirements.

### 2.5.1 CE mark

The measuring system meets the legal requirements of the applicable EC guidelines. These are listed in the corresponding EC Declaration of Conformity together with the standards applied.

Endress+Hauser confirms successful testing of the device by affixing to it the CE mark.

## 3 Product description

### 3.1 Product design

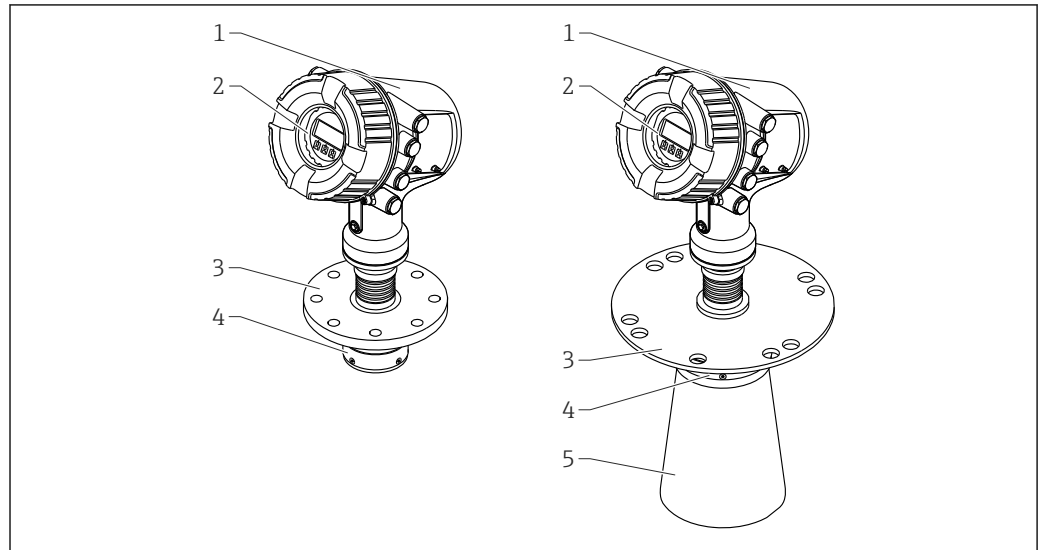

A0027766

 1 Design of Micropilot NMR84

- 1 Electronics housing
- 2 Display and operating module (can be operated without opening the cover)
- 3 Process connection (flange)
- 4 Planar antenna
- 5 Antenna extension (for antennas  $\geq 200$  mm (8 in))

## 4 Incoming acceptance and product identification

### 4.1 Incoming acceptance

Upon receipt of the goods check the following:

- Are the order codes on the delivery note and the product sticker identical?
- Are the goods undamaged?
- Do the nameplate data match the ordering information on the delivery note?
- If required (see nameplate): Are the Safety Instructions (XA) enclosed?



If one of these conditions is not satisfied, contact your Endress+Hauser Sales Center.

### 4.2 Product identification

The following options are available for identification of the measuring device:

- Nameplate specifications
- Extended order code with breakdown of the device features on the delivery note
- Enter serial numbers from nameplates in *W@M Device Viewer* ([www.endress.com/deviceviewer](http://www.endress.com/deviceviewer)): All information about the measuring device is displayed.
- Enter the serial number from the nameplates into the *Endress+Hauser Operations App* or scan the 2-D matrix code (QR code) on the nameplate with the *Endress+Hauser Operations App*: all the information for the measuring device is displayed.

For an overview of the scope of the associated Technical Documentation, refer to the following:

- The *W@M Device Viewer*: Enter the serial number from the nameplate ([www.endress.com/deviceviewer](http://www.endress.com/deviceviewer))
- The *Endress+Hauser Operations App*: Enter the serial number from the nameplate or scan the 2-D matrix code (QR code) on the nameplate.

## 4.2.1 Nameplate

1  
2  
3  
4  
5  
6  
7  
8  
9  
10  
11  
12  
13  
14  
15  
16  
17  
18  
19  
20  
21  
22  
23  
24  
25  
26  
27  
28

Endress+Hauser

Order code:  
Ser. no.:  
Ext. ord. cd.:  
MWP:  
Tp max.: Ta  
Mat.:  
DeviceID:  
FW: Dev.Rev.: ex works  
Tank ID:  
Tank ref.height:  
Density range: Kg/m<sup>3</sup>  
Ta:  
Date:  
x = if modification see sep. label

A0027791

### 2 Nameplate

- 1 Manufacturer address
- 2 Device name
- 3 Order code
- 4 Serial number
- 5 Extended order code
- 6 Supply voltage
- 7 Maximum process pressure
- 8 Maximum process temperature
- 9 Permitted ambient temperature ( $T_a$ )
- 10 Temperature resistance of cable
- 11 Thread for cable entry
- 12 Material in contact with process
- 13 Device ID
- 14 Firmware version
- 15 Device revision
- 16 Metrology certification numbers
- 17 Customized parametrization data
- 18 Ambient temperature range
- 19 CE mark / C-tick mark
- 20 Additional information on the device version
- 21 Ingress protection
- 22 Certificate symbol
- 23 Data concerning the Ex approval
- 24 General certificate of approval
- 25 Associated Safety Instructions (XA)
- 26 Manufacturing date
- 27 RoHS mark
- 28 QR code for the Endress+Hauser Operations App

## 4.2.2 Manufacturer address

Endress+Hauser SE+Co. KG  
Hauptstraße 1  
79689 Maulburg, Germany  
Address of the manufacturing plant: See nameplate.

## 4.3 Storage and transport

### 4.3.1 Storage conditions

- Storage temperature: -50 to +80 °C (-58 to +176 °F)
- Store the device in its original packaging.

### 4.3.2 Transport

**NOTICE**

**Housing or antenna may be damaged or break away.**

Risk of injury

- ▶ Transport the measuring device to the measuring point in its original packaging or at the process connection.
- ▶ Do not fasten lifting devices (hoisting slings, lifting eyes etc.) at the housing or the antenna but at the process connection. Take into account the mass center of the device in order to avoid unintended tilting.
- ▶ Comply with the safety instructions, transport conditions for devices over 18kg (39.6lbs) (IEC61010).

## 5 Installation

### 5.1 Installation conditions

#### 5.1.1 Conditions for the stilling well

- Metal (no enamel coating)
- Constant diameter (no rectangular stilling wells)
- Weld seam as smooth as possible
- For best radar propagation behavior it is recommended to have holes instead of slots. If slots can not be avoided, they should be as thin and short as possible.
- Maximum gap between antenna/horn and wall of the stilling well: 5 mm (0.2 in).
- At any transition (e.g. when using a ball valve or mending pipe segments) gaps must not exceed 1 mm (0.04 in).
- The stilling well must be smooth on the inside. Average roughness  $\leq 6.3 \mu\text{m}$  (0.248  $\mu\text{in}$ )
- Length and number of the holes do not affect the measurement. The hole diameter (deburred) can be 1/7 of the well diameter, but should not exceed 30 mm (1.2 in).
- An increase of the pipe diameter is possible if the minimum lengths according to the following figure and table are taken into account:

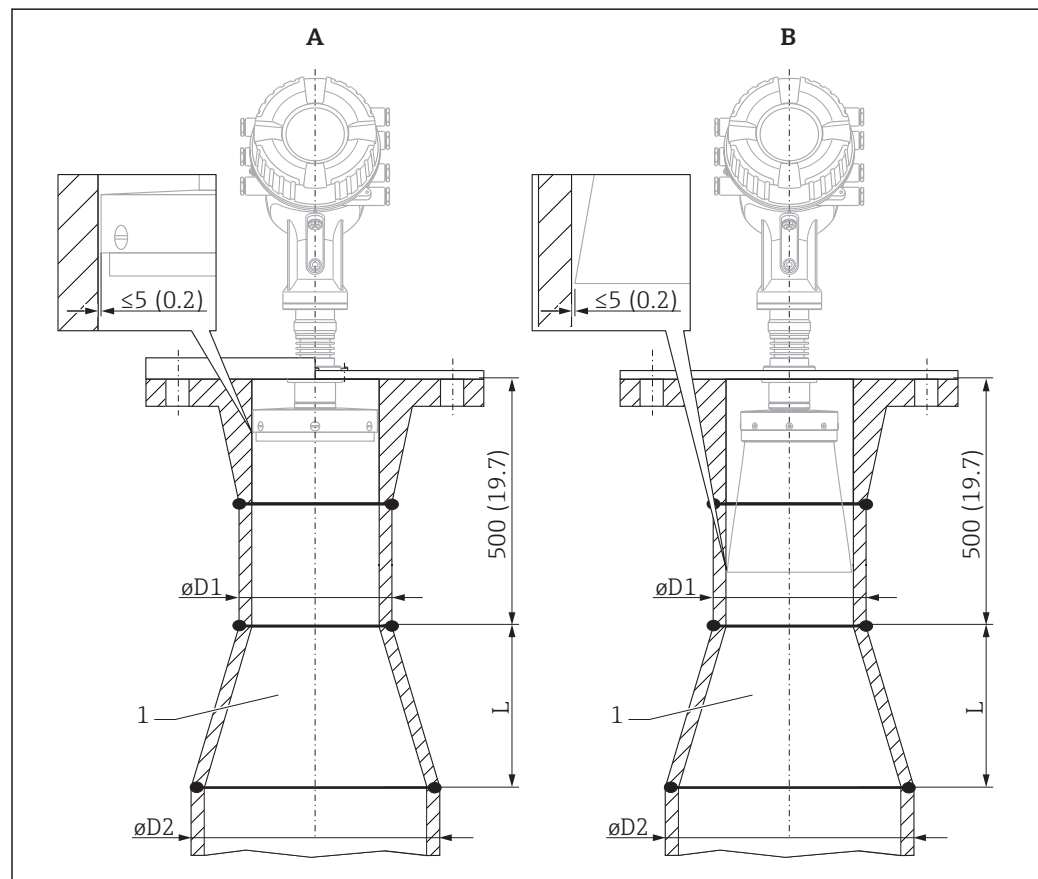

3 Installation of NMR84 in stilling wells with a larger diameter

A Antenna  $\leq 150$  mm (6 in) (without horn extension)

B Antenna  $\geq 200$  mm (8 in) (with horn extension)

1 Extension from  $\text{ØD1}$  to  $\text{ØD2}$



| D1 (= antenna size) | D2             | L              |
|---------------------|----------------|----------------|
| 100 mm (4 in)       | 150 mm (8 in)  | 300 mm (12 in) |
| 150 mm (6 in)       | 200 mm (8 in)  | 300 mm (12 in) |
| 200 mm (8 in)       | 250 mm (10 in) | 300 mm (12 in) |
| 250 mm (10 in)      | 300 mm (12 in) | 450 mm (18 in) |

## 5.2 Post-installation check

|                       |   |
|-----------------------|---|
| <input type="radio"/> | Is the device undamaged (visual inspection)?  |
| <input type="radio"/> | Does the device conform to the measuring point specifications?<br>For example: <ul style="list-style-type: none"> <li>▪ Process temperature</li> <li>▪ Process pressure (refer to the chapter on "Material load curves" of the "Technical Information" document)</li> <li>▪ Ambient temperature range</li> <li>▪ Measuring range</li> </ul> |
| <input type="radio"/> | Are the measuring point identification and labeling correct (visual inspection)?  |
| <input type="radio"/> | Is the device adequately protected from precipitation and direct sunlight?  |

## 6 Electrical connection

### 6.1 Terminal assignment

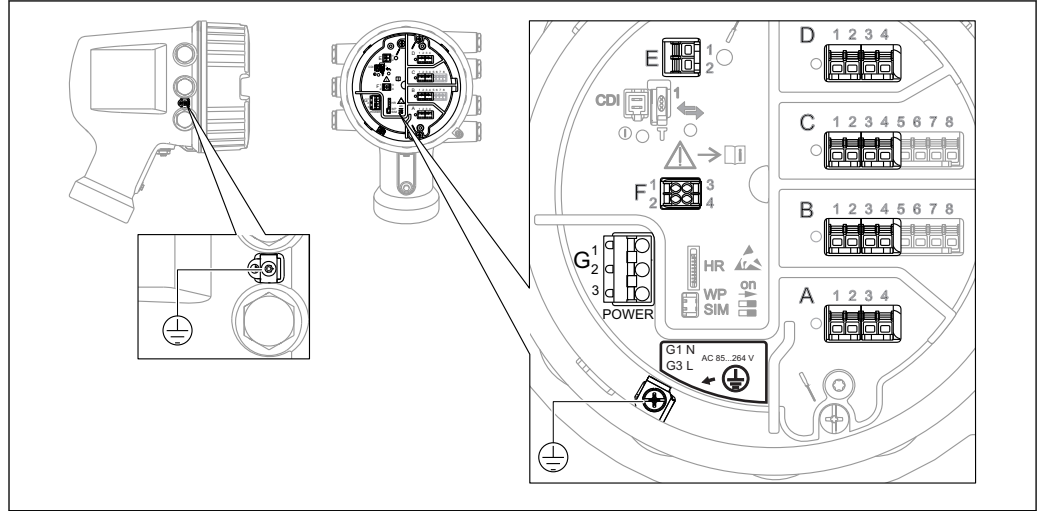

4 Terminal compartment (typical example) and ground terminals

| Terminal area                      | Module  |
|------------------------------------|---|
| A/B/C/D<br>(slots for I/O modules) | <p>Up to four I/O modules, depending on the order code</p> <ul style="list-style-type: none"> <li>Modules with four terminals can be in any of these slots.</li> <li>Modules with eight terminals can be in slot B or C.</li> </ul> <p><b>i</b> The exact assignment of the modules to the slots is dependent on the device version → 21.</p>       |
| E                                  | <p>HART Ex i/IS interface</p> <ul style="list-style-type: none"> <li>E1: H+</li> <li>E2: H-</li> </ul>  |
| F                                  | <p>Remote display</p> <ul style="list-style-type: none"> <li>F1: V<sub>CC</sub> (connect to terminal 81 of the remote display)</li> <li>F2: Signal B (connect to terminal 84 of the remote display)</li> <li>F3: Signal A (connect to terminal 83 of the remote display)</li> <li>F4: Gnd (connect to terminal 82 of the remote display)</li> </ul> |
| G                                  | <p>Power supply: 85 to 264 V<sub>AC</sub></p> <ul style="list-style-type: none"> <li>G1: N</li> <li>G2: not connected</li> <li>G3: L</li> </ul>   |
|                                    | <p>Protective ground connection (M4 screw)</p> <p>A0018339</p>  |

### 6.1.1 Power supply

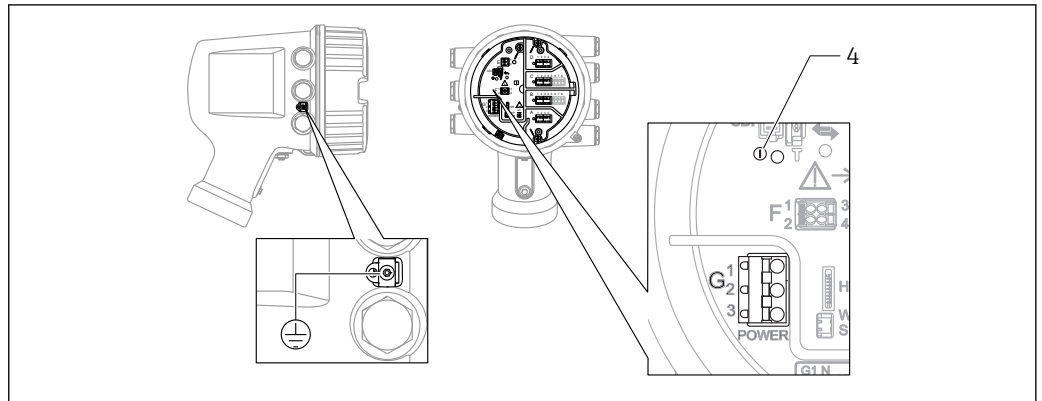

- G1 N
- G2 not connected
- G3 L
- 4 Green LED: indicates power supply

#### Supply voltage

85 to 264 V<sub>AC</sub>, 50/60 Hz, 28.8 VA <sup>1)</sup>

**i** The supply voltage is also indicated on the nameplate.

### 6.1.2 Remote display and operating module DKX001

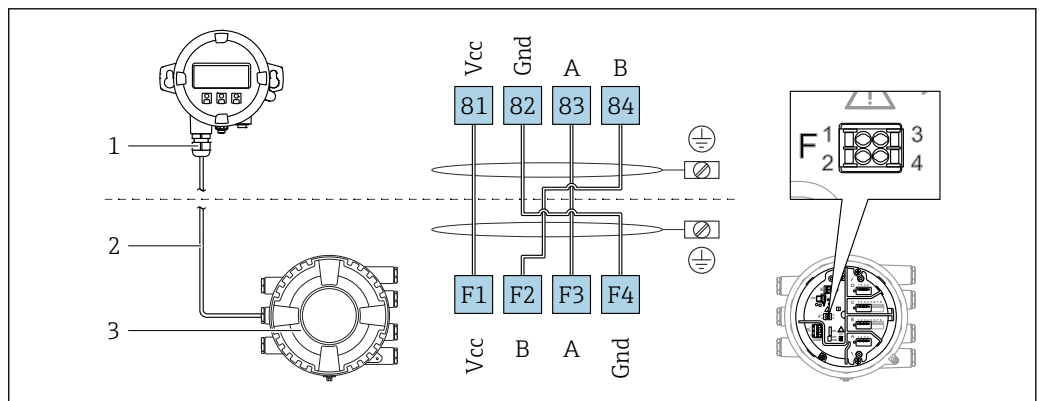

**5** Connection of the remote display and operating module DKX001 to the Tank Gauging device (NMR8x, NMS8x or NRF8x)

- 1 Remote display and operating module
- 2 Connecting cable
- 3 Tank Gauging device (NMR8x, NMS8x or NRF8x)

**i** The remote display and operating module DKX001 is available as an accessory. For details refer to SDO1763D.

- i**
  - The measured value is indicated on the DKX001 and on the local display and operating module simultaneously.
  - The operating menu cannot be accessed on both modules at the same time. If the operating menu is entered in one of these modules, the other module is automatically locked. This locking remains active until the menu is closed in the first module (back to measured value display).

1) maximum value; actual value depending on modules installed. 28.8 VA includes the nominal power, and the cabling specification has to meet this value. On the other hand, the effective power consumption is 12 W.

### 6.1.3 HART Ex i/IS interface

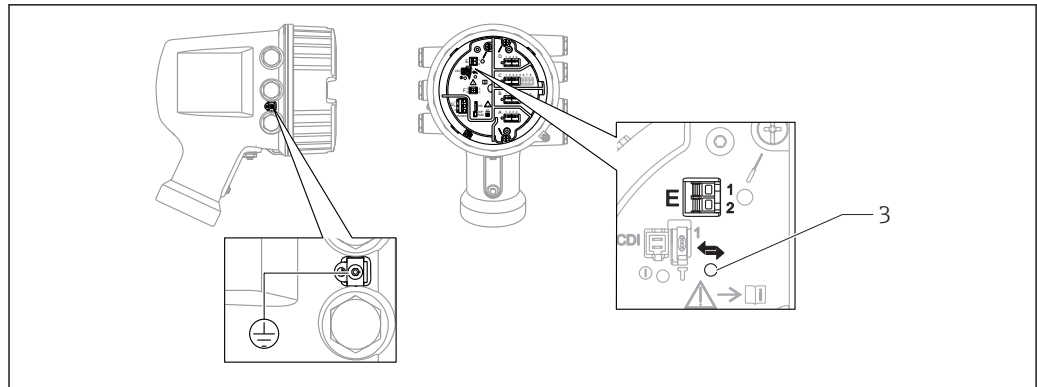

E1 H+

E2 H-

3 Orange LED: indicates data communication

**i** This interface always operates as the main HART master for connected HART slave transmitters. The Analog I/O modules, on the other hand, can be configured as a HART master or slave → [28](#) → [30](#).

### 6.1.4 Slots for I/O modules

The terminal compartment contains four slots (A, B, C and D) for I/O modules. Depending on the device version (ordering features 040, 050 and 060) these slots contain different I/O modules. The table below shows which module is located in which slot for a specific device version.

 The slot assignment for the device is also indicated on a label attached to the back cover of the display module.

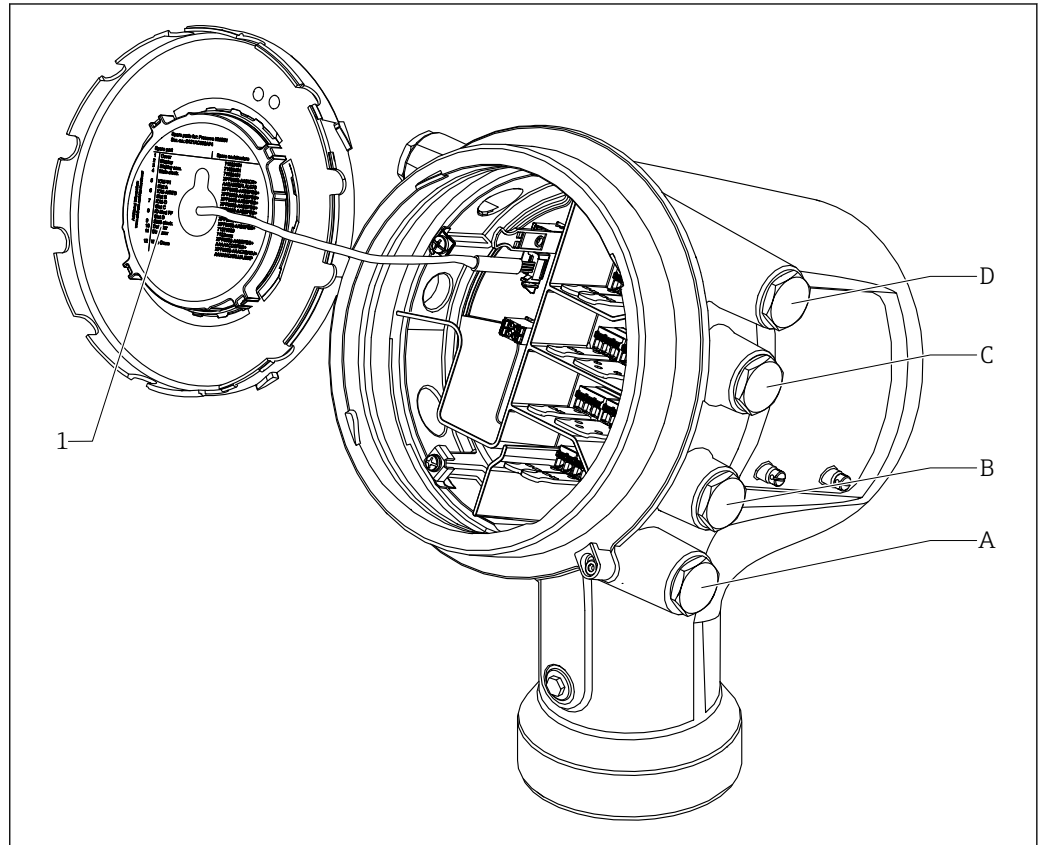

A0030070

- 1 Label showing (among other things) the modules in the slots A to D.
- A Cable entry for slot A
- B Cable entry for slot B
- C Cable entry for slot C
- D Cable entry for slot D

"Primary Output" (040) = "Modbus" (A1)

| Ordering feature  |                               |   | Terminal area |                |                |         |
|---|-------------------------------|---|---------------|----------------|----------------|---------|
| NMx8x - xxxx <u>XX</u> <u>XX</u> <u>XX</u> ...<br>040 050 060 |                               |   |               |                |                |         |
| 040<br>Primary<br>Output                                      | 050<br>Secondary<br>IO Analog | 060<br>Secondary<br>IO Digital<br>Ex d/XP |               |                |                |         |
| A1  | X0                            | X0  | Modbus        | -              | -              | -       |
| A1  | X0                            | A1  | Modbus        | -              | -              | Digital |
| A1  | X0                            | A2  | Modbus        | -              | Digital        | Digital |
| A1  | X0                            | A3  | Modbus        | Digital        | Digital        | Digital |
| A1  | X0                            | B1  | Modbus        | Modbus         | -              | -       |
| A1  | X0                            | B2  | Modbus        | Modbus         | -              | Digital |
| A1  | X0                            | B3  | Modbus        | Modbus         | Digital        | Digital |
| A1  | A1                            | X0  | Modbus        | Analog Ex d/XP | -              | -       |
| A1  | A1                            | A1  | Modbus        | Analog Ex d/XP | -              | Digital |
| A1  | A1                            | A2  | Modbus        | Analog Ex d/XP | Digital        | Digital |
| A1  | A1                            | B1  | Modbus        | Modbus         | Analog Ex d/XP | -       |
| A1  | A1                            | B2  | Modbus        | Modbus         | Analog Ex d/XP | Digital |
| A1  | A2                            | X0  | Modbus        | Analog Ex d/XP | Analog Ex d/XP | -       |
| A1  | A2                            | A1  | Modbus        | Analog Ex d/XP | Analog Ex d/XP | Digital |
| A1  | A2                            | B1  | Modbus        | Analog Ex d/XP | Analog Ex d/XP | Modbus  |
| A1  | B1                            | X0  | Modbus        | Analog Ex i/IS | -              | -       |
| A1  | B1                            | A1  | Modbus        | Analog Ex i/IS | -              | Digital |
| A1  | B1                            | A2  | Modbus        | Analog Ex i/IS | Digital        | Digital |
| A1  | B1                            | B1  | Modbus        | Modbus         | Analog Ex i/IS | -       |
| A1  | B1                            | B2  | Modbus        | Modbus         | Analog Ex i/IS | Digital |
| A1  | B2                            | X0  | Modbus        | Analog Ex i/IS | Analog Ex i/IS | -       |
| A1  | B2                            | A1  | Modbus        | Analog Ex i/IS | Analog Ex i/IS | Digital |
| A1  | B2                            | B1  | Modbus        | Analog Ex i/IS | Analog Ex i/IS | Modbus  |
| A1  | C2                            | X0  | Modbus        | Analog Ex i/IS | Analog Ex d/XP | -       |
| A1  | C2                            | A1  | Modbus        | Analog Ex i/IS | Analog Ex d/XP | Digital |
| A1  | C2                            | B1  | Modbus        | Analog Ex i/IS | Analog Ex d/XP | Modbus  |

"Primary Output" (040) = "V1" (B1)

| Ordering feature  |                               |   | Terminal area |                |                |         |
|---|-------------------------------|---|---------------|----------------|----------------|---------|
| NMx8x - xxxx <u>XX</u> <u>XX</u> <u>XX</u> ...<br>040 050 060 |                               |   |               |                |                |         |
| 040<br>Primary<br>Output                                      | 050<br>Secondary<br>IO Analog | 060<br>Secondary<br>IO Digital<br>Ex d/XP |               |                |                |         |
| B1  | X0                            | X0  | V1            | -              | -              | -       |
| B1  | X0                            | A1  | V1            | -              | -              | Digital |
| B1  | X0                            | A2  | V1            | -              | Digital        | Digital |
| B1  | X0                            | A3  | V1            | Digital        | Digital        | Digital |
| B1  | X0                            | B1  | V1            | Modbus         | -              | -       |
| B1  | X0                            | B2  | V1            | Modbus         | -              | Digital |
| B1  | X0                            | B3  | V1            | Modbus         | Digital        | Digital |
| B1  | A1                            | X0  | V1            | Analog Ex d/XP | -              | -       |
| B1  | A1                            | A1  | V1            | Analog Ex d/XP | -              | Digital |
| B1  | A1                            | A2  | V1            | Analog Ex d/XP | Digital        | Digital |
| B1  | A1                            | B1  | V1            | Modbus         | Analog Ex d/XP | -       |
| B1  | A1                            | B2  | V1            | Modbus         | Analog Ex d/XP | Digital |
| B1  | A2                            | X0  | V1            | Analog Ex d/XP | Analog Ex d/XP | -       |
| B1  | A2                            | A1  | V1            | Analog Ex d/XP | Analog Ex d/XP | Digital |
| B1  | A2                            | B1  | V1            | Analog Ex d/XP | Analog Ex d/XP | Modbus  |
| B1  | B1                            | X0  | V1            | Analog Ex i/IS | -              | -       |
| B1  | B1                            | A1  | V1            | Analog Ex i/IS | -              | Digital |
| B1  | B1                            | A2  | V1            | Analog Ex i/IS | Digital        | Digital |
| B1  | B1                            | B1  | V1            | Modbus         | Analog Ex i/IS | -       |
| B1  | B1                            | B2  | V1            | Modbus         | Analog Ex i/IS | Digital |
| B1  | B2                            | X0  | V1            | Analog Ex i/IS | Analog Ex i/IS | -       |
| B1  | B2                            | A1  | V1            | Analog Ex i/IS | Analog Ex i/IS | Digital |
| B1  | B2                            | B1  | V1            | Analog Ex i/IS | Analog Ex i/IS | Modbus  |
| B1  | C2                            | X0  | V1            | Analog Ex i/IS | Analog Ex d/XP | -       |
| B1  | C2                            | A1  | V1            | Analog Ex i/IS | Analog Ex d/XP | Digital |
| B1  | C2                            | B1  | V1            | Analog Ex i/IS | Analog Ex d/XP | Modbus  |

"Primary Output" (040) = "4-20mA HART Ex d" (E1)

| Ordering feature  |                               |   | Terminal area |                |                |         |
|---|-------------------------------|---|---------------|----------------|----------------|---------|
| NMx8x - xxxx <u>XX</u> <u>XX</u> <u>XX</u> ...<br>040 050 060 |                               |   |               |                |                |         |
| 040<br>Primary<br>Output                                      | 050<br>Secondary<br>IO Analog | 060<br>Secondary<br>IO Digital<br>Ex d/XP |               |                |                |         |
| E1  | X0                            | X0  | -             | Analog Ex d/XP | -              | -       |
| E1  | X0                            | A1  | -             | Analog Ex d/XP | -              | Digital |
| E1  | X0                            | A2  | -             | Analog Ex d/XP | Digital        | Digital |
| E1  | X0                            | A3  | Digital       | Analog Ex d/XP | Digital        | Digital |
| E1  | X0                            | B1  | Modbus        | Analog Ex d/XP | -              | -       |
| E1  | X0                            | B2  | Modbus        | Analog Ex d/XP | -              | Digital |
| E1  | X0                            | B3  | Modbus        | Analog Ex d/XP | Digital        | Digital |
| E1  | A1                            | X0  | -             | Analog Ex d/XP | Analog Ex d/XP | -       |
| E1  | A1                            | A1  | -             | Analog Ex d/XP | Analog Ex d/XP | Digital |
| E1  | A1                            | A2  | Digital       | Analog Ex d/XP | Analog Ex d/XP | Digital |
| E1  | A1                            | B1  | Modbus        | Analog Ex d/XP | Analog Ex d/XP | -       |
| E1  | A1                            | B2  | Modbus        | Analog Ex d/XP | Analog Ex d/XP | Digital |
| E1  | B1                            | X0  | -             | Analog Ex d/XP | Analog Ex i/IS | -       |
| E1  | B1                            | A1  | -             | Analog Ex d/XP | Analog Ex i/IS | Digital |
| E1  | B1                            | A2  | Digital       | Analog Ex d/XP | Analog Ex i/IS | Digital |
| E1  | B1                            | B1  | Modbus        | Analog Ex d/XP | Analog Ex i/IS | -       |
| E1  | B1                            | B2  | Modbus        | Analog Ex d/XP | Analog Ex i/IS | Digital |



"Primary Output" (040) = "4-20mA HART Ex i" (H1)

| Ordering feature  |                               |   | Terminal area |                |                |         |
|---|-------------------------------|---|---------------|----------------|----------------|---------|
| NMx8x - xxxx <u>XX</u> <u>XX</u> <u>XX</u> ...<br>040 050 060 |                               |   |               |                |                |         |
| 040<br>Primary<br>Output                                      | 050<br>Secondary<br>IO Analog | 060<br>Secondary<br>IO Digital<br>Ex d/XP |               |                |                |         |
| H1  | X0                            | X0  | -             | Analog Ex i/IS | -              | -       |
| H1  | X0                            | A1  | -             | Analog Ex i/IS | -              | Digital |
| H1  | X0                            | A2  | -             | Analog Ex i/IS | Digital        | Digital |
| H1  | X0                            | A3  | Digital       | Analog Ex i/IS | Digital        | Digital |
| H1  | X0                            | B1  | Modbus        | Analog Ex i/IS | -              | -       |
| H1  | X0                            | B2  | Modbus        | Analog Ex i/IS | -              | Digital |
| H1  | X0                            | B3  | Modbus        | Analog Ex i/IS | Digital        | Digital |
| H1  | A1                            | X0  | -             | Analog Ex i/IS | Analog Ex d/XP | -       |
| H1  | A1                            | A1  | -             | Analog Ex i/IS | Analog Ex d/XP | Digital |
| H1  | A1                            | A2  | Digital       | Analog Ex i/IS | Analog Ex d/XP | Digital |
| H1  | A1                            | B1  | Modbus        | Analog Ex i/IS | Analog Ex d/XP | -       |
| H1  | A1                            | B2  | Modbus        | Analog Ex i/IS | Analog Ex d/XP | Digital |
| H1  | B1                            | X0  | -             | Analog Ex i/IS | Analog Ex i/IS | -       |
| H1  | B1                            | A1  | -             | Analog Ex i/IS | Analog Ex i/IS | Digital |
| H1  | B1                            | A2  | Digital       | Analog Ex i/IS | Analog Ex i/IS | Digital |
| H1  | B1                            | B1  | Modbus        | Analog Ex i/IS | Analog Ex i/IS | -       |
| H1  | B1                            | B2  | Modbus        | Analog Ex i/IS | Analog Ex i/IS | Digital |

### 6.1.5 Terminals of the "Modbus" or "V1" module

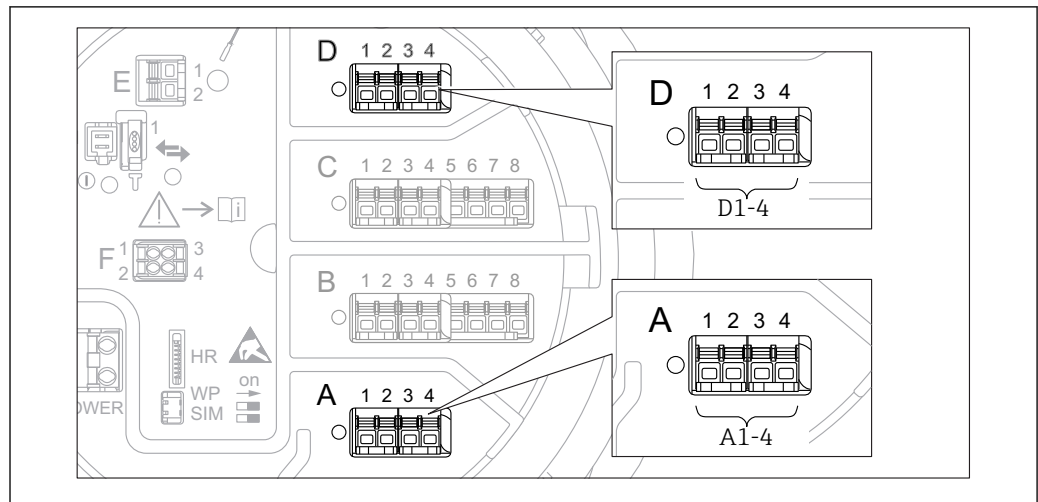

6 Designation of the "Modbus" or "V1" modules (examples); depending on the device version these modules may also be in slot B or C.

Depending on the device version, the "Modbus" and/or "V1" module may be in different slots of the terminal compartment. In the operating menu the "Modbus" and "V1" interfaces are designated by the respective slot and the terminals within this slot: **A1-4**, **B1-4**, **C1-4**, **D1-4**.

#### Terminals of the "Modbus" module

| Terminal <sup>1)</sup>   | Name | Description  |
|--|------|--|
| X1   | S    | Cable shielding connected via a capacitor to EARTH |
| X2   | 0V   | Common reference                                   |
| X3   | B-   | Non-inverting signal line                          |
| X4   | A+   | Inverting signal line                              |
| Designation of the module in the operating menu: <b>Modbus X1-4</b> ; (X = A, B, C or D) |      |  |

1) In this column, "X" stands for one of the slots "A", "B", "C", or "D".

#### Terminals of the "V1" module

| Terminal <sup>1)</sup>   | Name | Description                                      |
|--|------|--|
| X1   | S    | Cable shielding connected via capacitor to EARTH |
| X2   |      | not connected                                    |
| X3   | B-   | Protocol loop signal -                           |
| X4   | A+   | Protocol loop signal +                           |
| Designation of the module in the operating menu: <b>V1 X1-4</b> ; (X = A, B, C or D) |      |  |

1) In this column, "X" stands for one of the slots "A", "B", "C", or "D".

### 6.1.6 Terminals of the "Analog I/O" module (Ex d /XP or Ex i/IS)

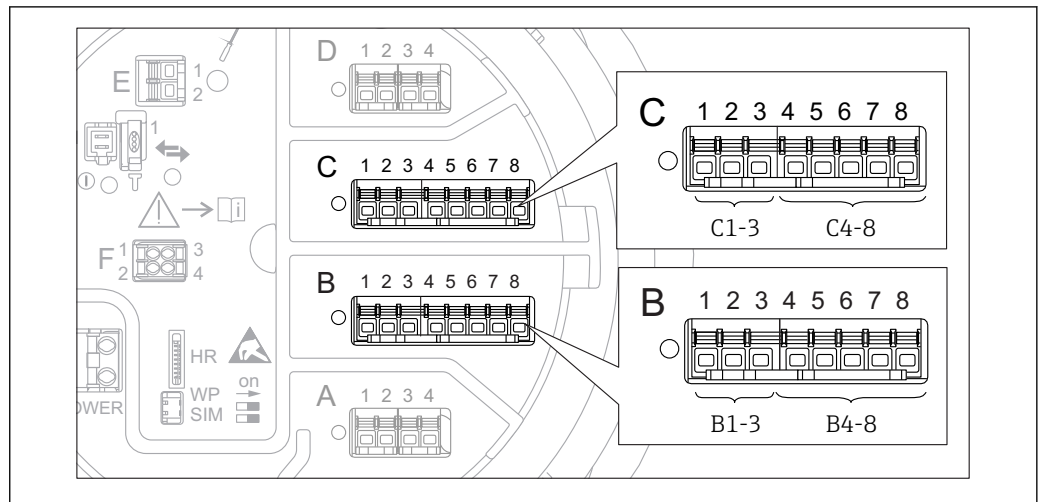

A0031168

| Terminals | Function                              | Connection diagrams   | Designation in the operating menu |
|-----------|---------------------------------------|---|-----------------------------------|
| B1-3      | Analog input or output (configurable) | <ul style="list-style-type: none"> <li>■ Passive usage: → ☰ 28</li> <li>■ Active usage: → ☰ 30</li> </ul> | Analog I/O B1-3 (→ ☰ 140)         |
| C1-3      |                                       |   | Analog I/O C1-3 (→ ☰ 140)         |
| B4-8      | Analog input                          | RTD: → ☰ 31   | Analog IP B4-8 (→ ☰ 134)          |
| C4-8      |                                       |   | Analog IP C4-8 (→ ☰ 134)          |

### 6.1.7 Connection of the "Analog I/O" module for passive usage

- i** In the passive usage the supply voltage for the communication line must be supplied by an external source.
- The wiring must be in accordance with the intended operating mode of the Analog I/O module; see the drawings below.
- Screened cable must be used for the 4...20mA signal line.

"Operating mode" = "4..20mA output" or "HART slave +4..20mA output"

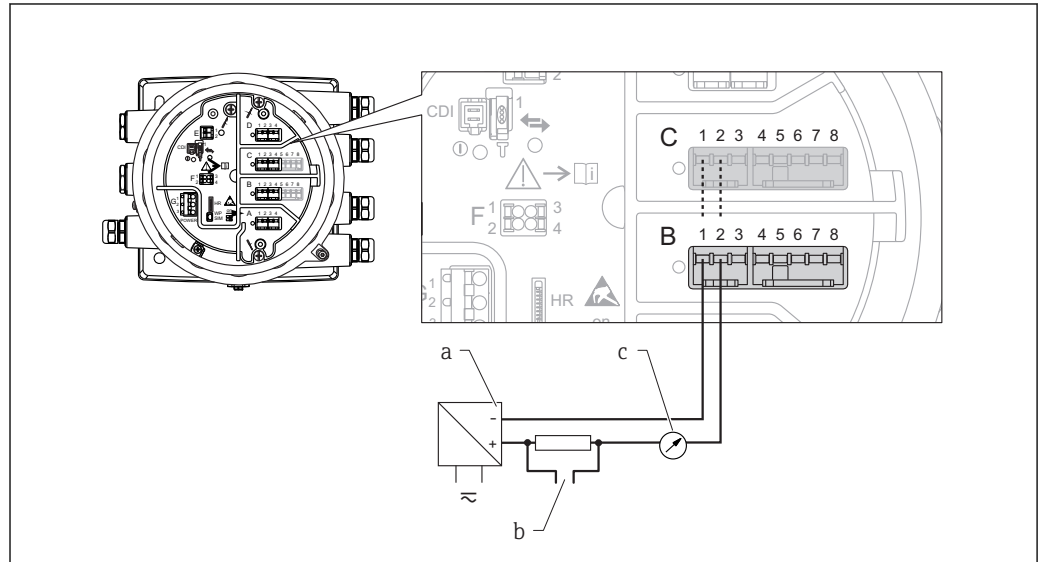

A0027931

**7** Passive usage of the Analog I/O module in the output mode

- a Power supply
- b HART signal output
- c Analog signal evaluation

"Operating mode" = "4..20mA input" or "HART master+4..20mA input"

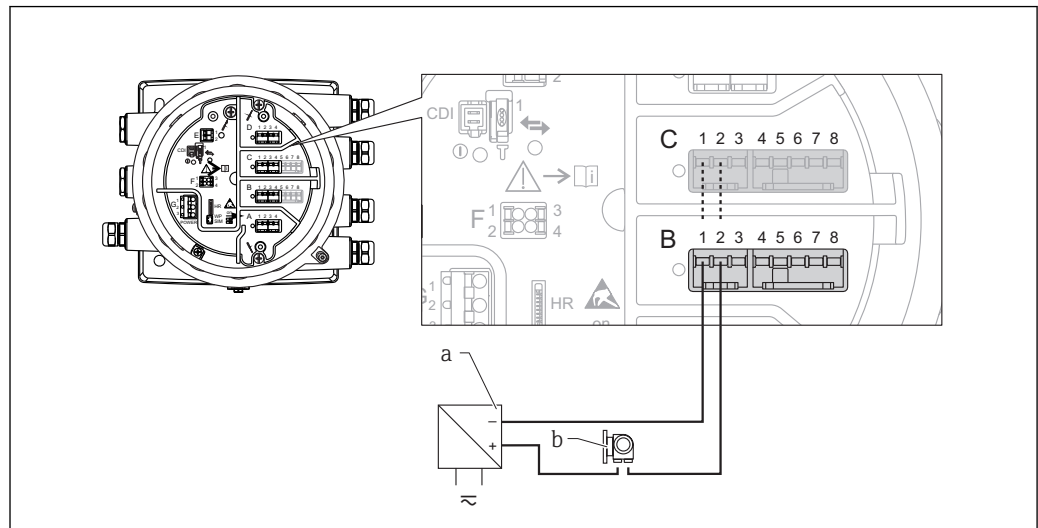

A0027933

**8** Passive usage of the Analog I/O module in the input mode

- a Power supply
- b External device with 4...20mA and/or HART signal output

"Operating mode" = "HART master"

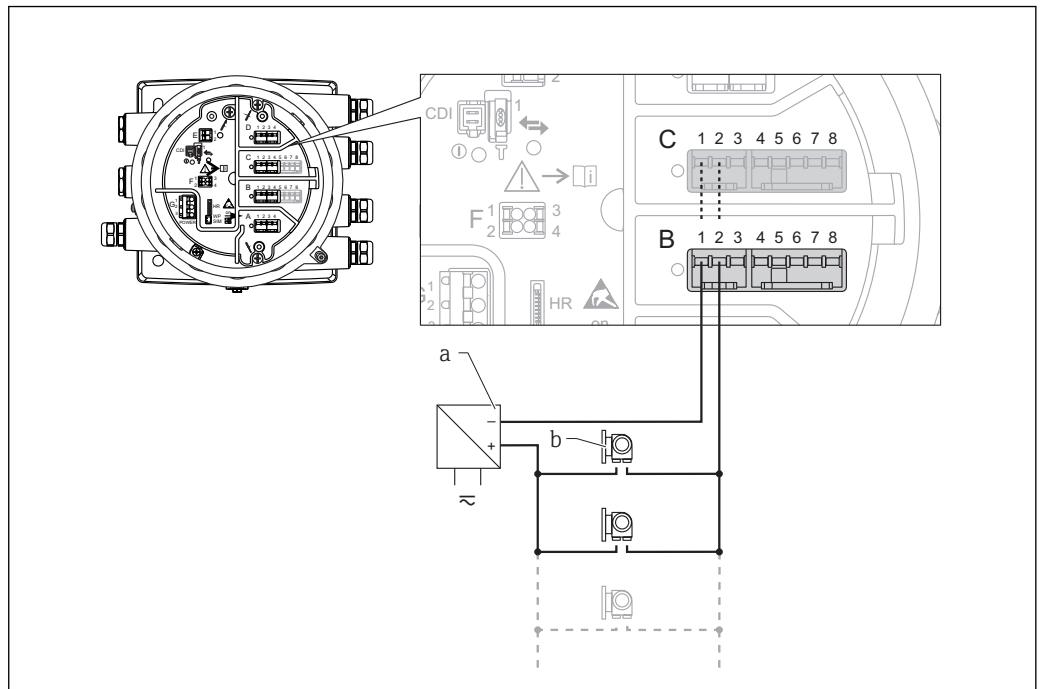

A0027934

9 Passive usage of the Analog I/O module in the HART master mode

- a Power supply
- b Up to 6 external devices with HART signal output

### 6.1.8 Connection of the "Analog I/O" module for active usage

- i** In the active usage the supply voltage for the communication line is supplied by the device itself. There is no need of an external power supply.
  - The wiring must be in accordance with the intended operating mode of the Analog I/O module; see the drawings below.
  - Screened cable must be used for the 4...20mA signal line.
- i** Maximum current consumption of the connected HART devices: 24 mA (i.e. 4 mA per device if 6 devices are connected).
  - Output voltage of the Ex-d module: 17.0 V@4 mA to 10.5 V@22 mA
  - Output voltage of the Ex-ia module: 18.5 V@4 mA to 12.5 V@22 mA

"Operating mode" = "4..20mA output" or "HART slave +4..20mA output"

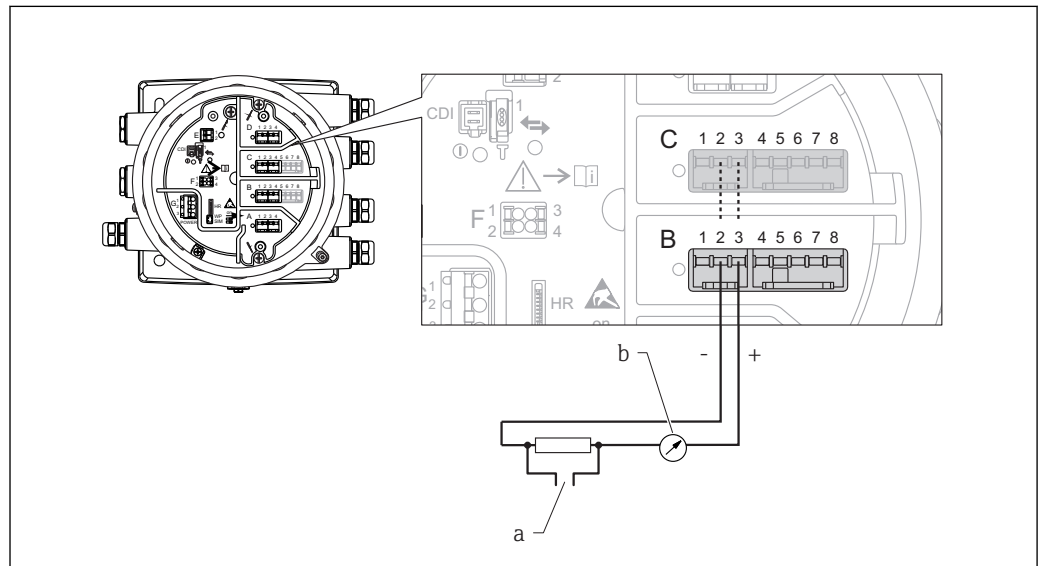

A0027932

**10** Active usage of the Analog I/O module in the output mode

- a HART signal output
- b Analog signal evaluation

"Operating mode" = "4..20mA input" or "HART master+4..20mA input"

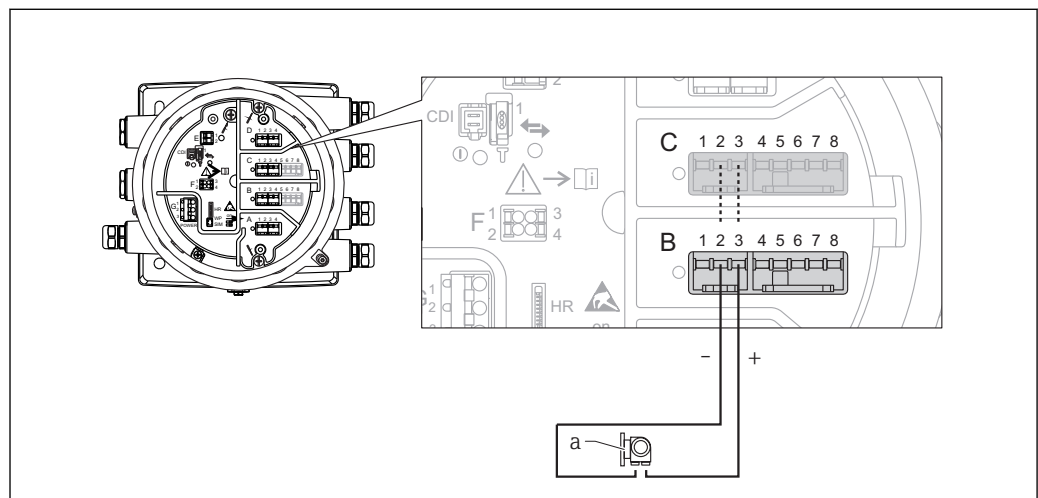

A0027935

**11** Active usage of the Analog I/O module in the input mode

- a External device with 4...20mA and/or HART signal output

**"Operating mode" = "HART master"**

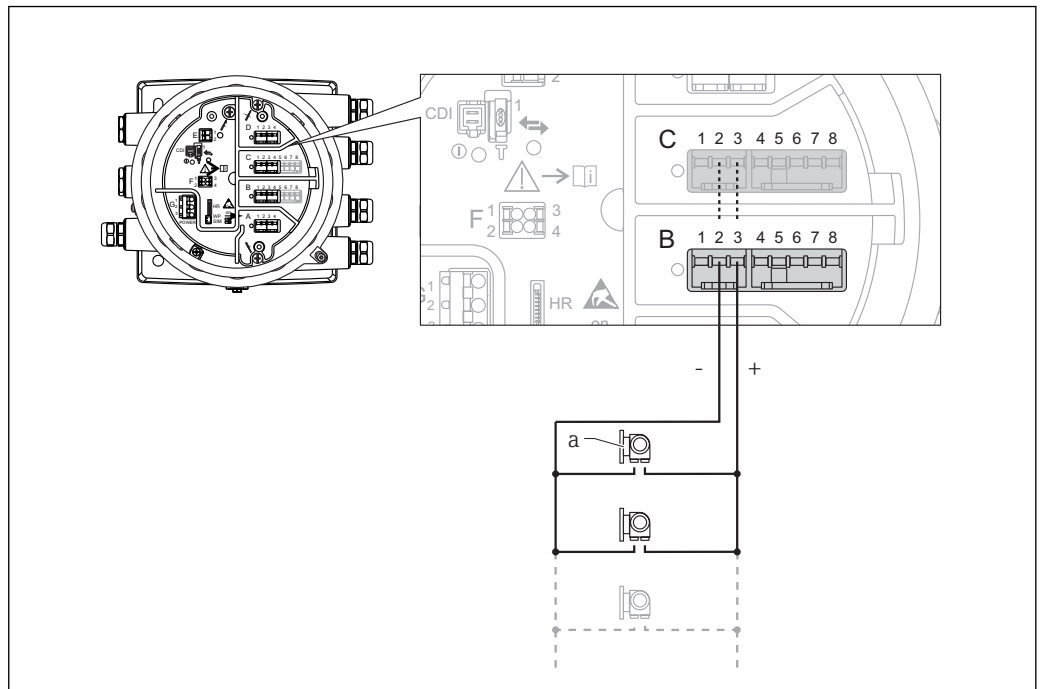

A0027936

12 Active usage of the Analog I/O module in the HART master mode

a Up to 6 external devices with HART signal output

**i** The maximum current consumption for the connected HART devices is 24 mA (i.e. 4 mA per device if 6 devices are connected).

**6.1.9 Connection of a RTD**

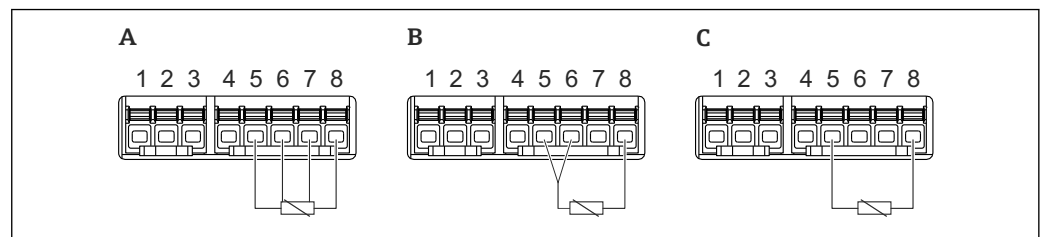

A0026371

A 4-wire RTD connection

B 3-wire RTD connection

C 2-wire RTD connection

**i** Screened cable must be used for the connection of the RTD.

### 6.1.10 Terminals of the "Digital I/O" module

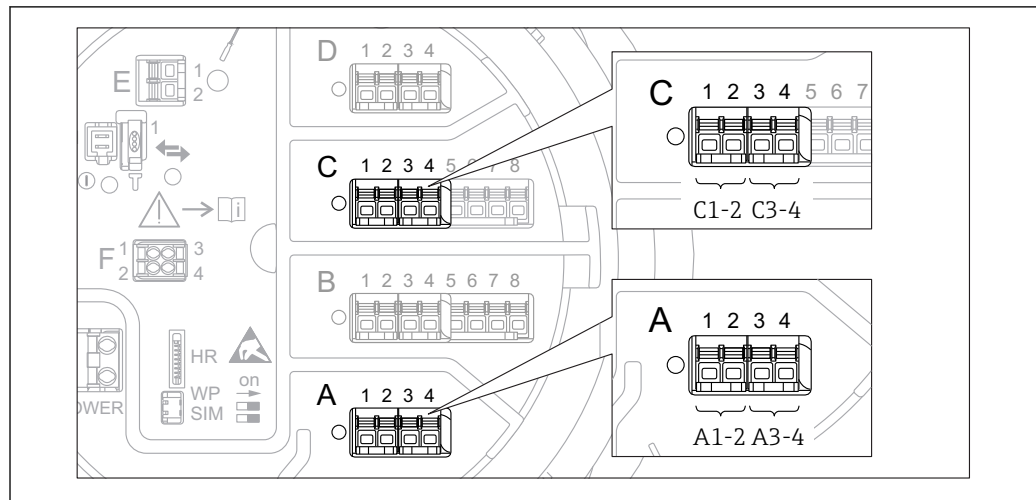

13 Designation of the digital inputs or outputs (examples)

- Each Digital IO Module provides two digital inputs or outputs.
- In the operating menu each input or output is designated by the respective slot and two terminals within this slot. **A1-2**, for example, denotes terminals 1 and 2 of slot **A**. The same is valid for slots **B**, **C** and **D** if they contain a Digital IO module.
- For each of these pairs of terminals, one of the following operating modes can be selected in the operating menu:
  - Disable
  - Passive Output
  - Passive Input
  - Active Input



## 6.2 Connecting requirements

### 6.2.1 Cable specification

#### Terminals

| Terminal  | Wire cross section                        |
|---|---|
| Signal and power supply <ul style="list-style-type: none"> <li>▪ Spring terminals (NMx8x-xx1...)</li> <li>▪ Screw terminals (NMx8x-xx2...)</li> </ul> | 0.2 to 2.5 mm <sup>2</sup> (24 to 13 AWG) |
| Ground terminal in the terminal compartment   | max. 2.5 mm <sup>2</sup> (13 AWG)         |
| Ground terminal at the housing  | max. 4 mm <sup>2</sup> (11 AWG)           |

#### Power supply line

Standard device cable is sufficient for the power line.

#### Analog signal lines

Screened cable must be used for:

- the 4...20mA signal lines.
- the RTD connection.

#### HART communication line

Shielded cable is recommended if using the HART protocol. Observe the grounding concept of the plant.

#### Modbus communication line

- Observe the cable conditions from the TIA-485-A, Telecommunications Industry Association.
- Additional conditions: Use shielded cable.

#### V1 communication line

- Two wire (twisted pair) screened or un-screened cable
- Resistance in one cable:  $\leq 120 \Omega$
- Capacitance between lines:  $\leq 0.3 \mu\text{F}$

### 6.3 Ensuring the degree of protection

To guarantee the specified degree of protection, carry out the following steps after the electrical connection:

1. Check that the housing seals are clean and fitted correctly. Dry, clean or replace the seals if necessary.
2. Tighten all housing screws and screw covers.
3. Firmly tighten the cable glands.
4. To ensure that moisture does not enter the cable entry, route the cable so that it loops down before the cable entry ("water trap").

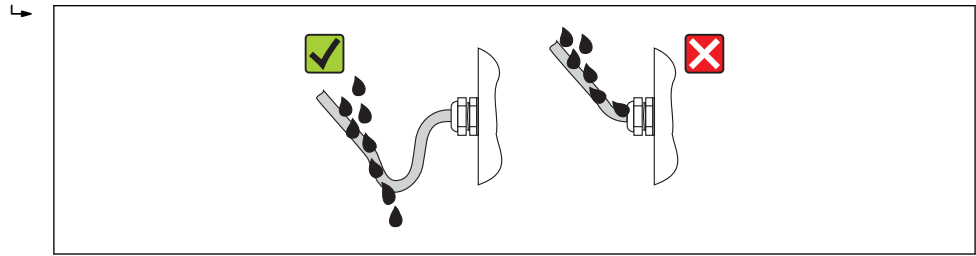

A0013960

5. Insert blind plugs appropriate for the safety rating of the device (e.g. Ex d/XP).





### 6.4 Post-connection check

|                       |   |
|-----------------------|---|
| <input type="radio"/> | Are cables or the device undamaged (visual inspection)?   |
| <input type="radio"/> | Do the cables comply with the requirements?   |
| <input type="radio"/> | Do the cables have adequate strain relief?  |
| <input type="radio"/> | Are all cable glands installed, firmly tightened and correctly sealed?                                      |
| <input type="radio"/> | Does the supply voltage match the specifications on the transmitter nameplate?                              |
| <input type="radio"/> | Is the terminal assignment correct → 18?  |
| <input type="radio"/> | If required: Is the protective earth connected correctly ?  |
| <input type="radio"/> | If supply voltage is present: Is the device ready for operation and do values appear on the display module? |
| <input type="radio"/> | Are all housing covers installed and firmly tightened?  |
| <input type="radio"/> | Is the securing clamp tightened correctly?  |

## 7 Operability

### 7.1 Overview of the operation options

The device is operated via an operating menu →  36. This menu can be accessed by the following interfaces:

- The display and operating module at the device or the remote display and operating module DKX001 (→  37).
- FieldCare connected through the service interface in the terminal compartment of the device (→  49).
- FieldCare connected through Tankvision Tank Scanner NXA820 (remote operation; →  50).
- FieldCare connected through Commubox FXA195 (→  101) to a HART interface of the device.

## 7.2 Structure and function of the operating menu

| Menu  | Submenu / parameter       | Meaning   |
|---|---------------------------|---|
| <b>Operation</b>  | <b>Level</b>              | Shows the measured and calculated level values.   |
|   | <b>Temperature</b>        | Shows the measured and calculated temperature values.   |
|   | <b>Density</b>            | Shows the measured and calculated density values.   |
|   | <b>Pressure</b>           | Shows the measured and calculated pressure values.  |
|   | <b>GP values</b>          | Shows the general purpose values.   |
| <b>Setup</b>  | Parameters 1 to N         | Standard commissioning parameters   |
|   | <b>Advanced setup</b>     | Contains further parameters and submenus: <ul style="list-style-type: none"> <li>▪ to adapt the device to special measuring conditions.</li> <li>▪ to process the measured value.</li> <li>▪ to configure the signal output.</li> </ul>             |
| <b>Diagnostics</b>  | Diagnostic parameters     | Indicates: <ul style="list-style-type: none"> <li>▪ The latest diagnostic messages and their timestamps.</li> <li>▪ The operating time (overall time and time since last restart).</li> <li>▪ The time according to the real-time clock.</li> </ul> |
|   | <b>Diagnostic list</b>    | Contains up to 5 currently active error messages.   |
|   | <b>Device information</b> | Contains information needed to identify the device.   |
|   | <b>Simulation</b>         | Used to simulate measured values or output values.  |
|   | <b>Device check</b>       | Contains all parameters needed to check the measurement capability of the device.   |
| <b>Expert</b> <sup>1)</sup><br>Contains all parameters of the device (including those which are already contained in one of the other menus). This menu is organized according to the function blocks of the device.<br><br>The parameter of the <b>Expert</b> menu are described in:<br>GP01071G (NMR84) | <b>System</b>             | Contains all general device parameters which do not affect the measurement or the communication interface.  |
|   | <b>Sensor</b>             | Contains all parameters needed to configure the measurement.  |
|   | <b>Input/output</b>       | Contains submenus to configure the analog and discrete I/O modules and connected HART devices.  |
|   | <b>Communication</b>      | Contains all parameters needed to configure the digital communication interface.  |
|   | <b>Application</b>        | Contains submenus to configure <ul style="list-style-type: none"> <li>▪ the tank gauging application</li> <li>▪ the tank calculations</li> <li>▪ the alarms.</li> </ul>   |
|   | <b>Tank values</b>        | Shows measured and calculated tank values   |
|   | <b>Diagnostics</b>        | Contains all parameters needed to detect and analyze operational errors.  |

1) On entering the "Expert" menu, an access code is always requested. If a customer specific access code has not been defined, "0000" has to be entered.

## 7.3 Access to the operating menu via the local or remote display and operating module.

- i
  - Operating via the remote display and operating module DKX001 (→  19) or the local display and operating module at the device are equivalent.
  - The measured value is indicated on the DKX001 and on the local display and operating module simultaneously.
  - The operating menu cannot be accessed on both modules at the same time. If the operating menu is entered in one of these modules, the other module is automatically locked. This locking remains active until the menu is closed in the first module (back to measured value display).

### 7.3.1 Display and operating elements

The device has an illuminated **liquid crystal display (LCD)** that shows measured and calculated values as well as the device status in the standard view. Other views are used to navigate through the operating menu and to set parameter values.

The device is operated by **three optical keys**, namely "-", "+" and "E". They are actuated when the appropriate field on the protective glass of the front is touched with the finger ("touch control").

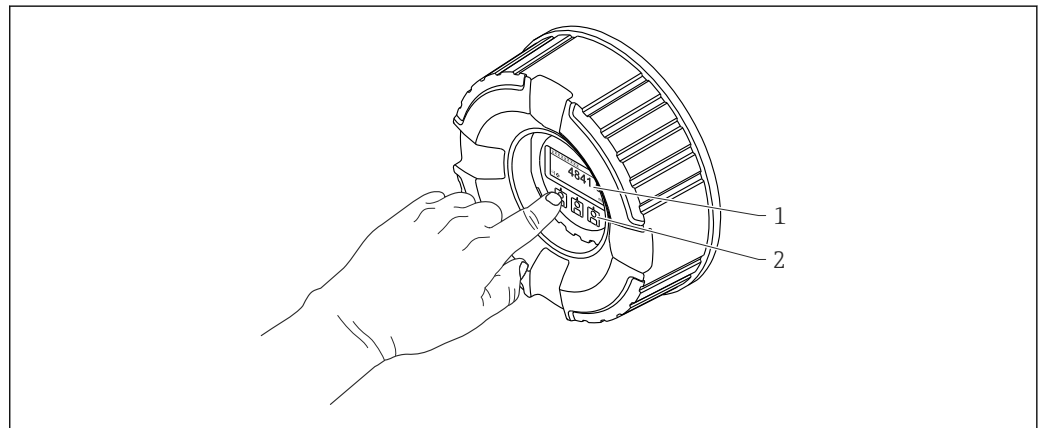

A0028345

 14 Display and operating elements

- 1 Liquid crystal display (LCD)
- 2 Optical keys; can be operated through the cover glass.

### 7.3.2 Standard view (measured value display)

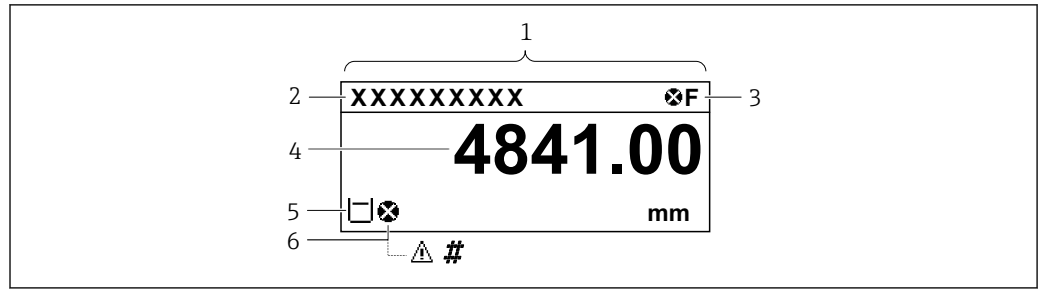

A0028317

15 Typical appearance of the standard view (measured value display)















- 1 Display module
- 2 Device tag
- 3 Status area
- 4 Display area for measured values
- 5 Display area for measured value and status symbols
- 6 Measured value status symbol

#### Status symbols



| Symbol               | Meaning   |
|----------------------|---|
| <b>F</b><br>A0013956 | <b>"Failure"</b><br>A device error is present. The measured value is no longer valid.   |
| <b>C</b><br>A0013959 | <b>"Function check"</b><br>The device is in service mode (e.g. during a simulation).  |
| <b>S</b><br>A0013958 | <b>"Out of specification"</b><br>The device is operated: <ul style="list-style-type: none"> <li>▪ Outside of its technical specifications (e.g. during startup or a cleaning)</li> <li>▪ Outside of the configuration carried out by the user (e.g. level outside configured span)</li> </ul> |
| <b>M</b><br>A0013957 | <b>"Maintenance required"</b><br>Maintenance is required. The measured value is still valid.  |

#### Measured value symbols



| Symbol 1             | Symbol 2             | Measured value   |
|----------------------|----------------------|--|
| <br>A0028148         |                      | <ul style="list-style-type: none"> <li>▪ Tank level</li> <li>▪ Measured level</li> <li>▪ Tank level %</li> </ul> |
| <br>A0028149         |                      | Water level  |
| <b>T</b><br>A0028528 |                      | Liquid temperature   |
| <b>T</b><br>A0028528 | <b>U</b><br>A0027990 | Vapor temperature  |
| <b>T</b><br>A0028528 | <b>A</b><br>A0027991 | Air temperature  |
| <br>A0027993         |                      | <ul style="list-style-type: none"> <li>▪ Tank ullage</li> <li>▪ Tank ullage %</li> </ul>                         |
| <b>ρ</b><br>A0028150 |                      | Observed density value   |

| Symbol 1  | Symbol 2  | Measured value                                     |
|---|---|--|
| <br>A0028151 | <br>A0028141 | P1 (bottom)  |
| <br>A0028151 | <br>A0028142 | P2 (middle)  |
| <br>A0028151 | <br>A0028146 | P3 (top)   |
| <br>A0027992 | <br>A0028141 | GP 1 value<br>This is used for an external device. |
| <br>A0027992 | <br>A0028142 | GP 2 value<br>This is used for an external device. |
| <br>A0027992 | <br>A0028146 | GP 3 value<br>This is used for an external device. |
| <br>A0027992 | <br>A0028147 | GP 4 value<br>This is used for an external device. |

*Measured value status symbols*

| Symbol  | Meaning  |
|---|--|
| <br>A0012102 | <b>Status "Alarm"</b><br>The measurement is interrupted. The output assumes the defined alarm value. A diagnostic message is generated.  |
| <br>A0012103 | <b>Status "Warning"</b><br>The device continues measuring. A diagnostic message is generated.  |
| <br>A0031169 | <b>Calibration to regulatory standards disturbed</b><br>Is displayed in the following situations: <ul style="list-style-type: none"> <li>▪ The write protection switch is OFF. → 47</li> <li>▪ The write protection switch is ON but the level value can currently not be guaranteed.</li> </ul> |

*Locking state symbols*

| Symbol  | Meaning   |
|---|---|
| <br>A0011978 | <b>Display parameter</b><br>Marks display-only parameters which cannot be edited.   |
| <br>A0011979 | <b>Device locked</b> <ul style="list-style-type: none"> <li>▪ In front of a parameter name: The device is locked via software and/or hardware.</li> <li>▪ In the header of the measured value screen: The device is locked via hardware.</li> </ul> |

*Meaning of the keys in the standard view*

| Key   | Meaning   |
|---|---|
| <br>A0028326 | <b>Enter key</b> <ul style="list-style-type: none"> <li>▪ Pressing the key briefly opens the operating menu.</li> <li>▪ Pressing the key for 2 s opens the context menu:                             <ul style="list-style-type: none"> <li>- <b>Level</b> (visible if the keylock is inactive): Shows the measured levels.</li> <li>- <b>Keylock on</b> (visible if the keylock is inactive): Activates the keylock.</li> <li>- <b>Keylock off</b> (visible if the keylock is active): Deactivates the keylock.</li> </ul> </li> </ul> |

### 7.3.3 Navigation view

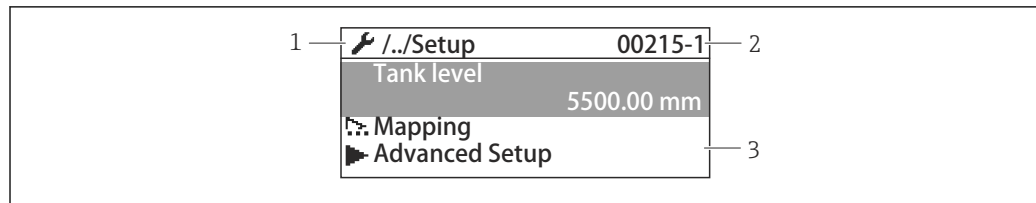







A0028346-EN

16 Navigation view





- 1 Current submenu or wizard
- 2 Quick access code
- 3 Display area for navigation

#### Navigation symbols

| Symbol  | Meaning   |
|---|---|
| <br>A0011975   | <b>Operation</b><br>Is displayed: <ul style="list-style-type: none"> <li>▪ in the main menu next to the selection <b>Operation</b></li> <li>▪ in the header, if you are in the <b>Operation</b> menu.</li> </ul>      |
| <br>A0011974   | <b>Setup</b><br>Is displayed: <ul style="list-style-type: none"> <li>▪ in the main menu next to the selection <b>Setup</b></li> <li>▪ in the header, if you are in the <b>Setup</b> menu</li> </ul>                   |
| <br>A0011976 | <b>Expert</b><br>Is displayed: <ul style="list-style-type: none"> <li>▪ in the main menu next to the selection <b>Expert</b></li> <li>▪ in the header, if you are in the <b>Expert</b> menu</li> </ul>                |
| <br>A0011977 | <b>Diagnostics</b><br>Is displayed: <ul style="list-style-type: none"> <li>▪ in the main menu next to the selection <b>Diagnostics</b></li> <li>▪ in the header, if you are in the <b>Diagnostics</b> menu</li> </ul> |
| <br>A0013967 | <b>Submenu</b>  |
| <br>A0013968 | <b>Wizard</b>   |
| <br>A0013963 | <b>Parameter locked</b><br>When displayed in front of a parameter name, indicates that the parameter is locked.   |



*Meaning of the keys in the navigation view*

| Key  | Meaning  |
|--|--|
|  <p style="text-align: right; font-size: small;">A0028324</p> | <p><b>Minus key</b><br/>                     Moves the selection bar upwards in a picklist.</p>  |
|  <p style="text-align: right; font-size: small;">A0028325</p> | <p><b>Plus key</b><br/>                     Moves the selection bar downwards in a picklist.</p>   |
|  <p style="text-align: right; font-size: small;">A0028326</p> | <p><b>Enter key</b></p> <ul style="list-style-type: none"> <li>▪ Pressing the key briefly opens the selected menu, submenu or parameter.</li> <li>▪ For parameters: Pressing the key for 2 s opens the help text for the function of the parameter (if present).</li> </ul>  |
|  <p style="text-align: right; font-size: small;">A0028327</p> | <p><b>Escape key combination (press keys simultaneously)</b></p> <ul style="list-style-type: none"> <li>▪ Pressing the keys briefly                             <ul style="list-style-type: none"> <li>- Exits the current menu level and takes you to the next higher level.</li> <li>- If help text is open, closes the help text of the parameter.</li> </ul> </li> <li>▪ Pressing the keys for 2 s returns you to the measured value display ("standard view").</li> </ul> |



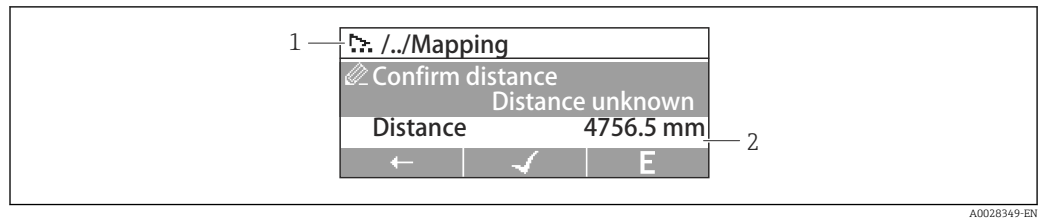

### 7.3.4 Wizard view



17 Wizard view on the display module

- 1 Current wizard
- 2 Display area for navigation

#### Wizard navigation symbols

| Symbol   | Meaning  |
|--|--|
| <br>A0013972  | Parameters within a wizard                                       |
| <br>A0013978  | Switches to the previous parameter.                              |
| <br>A0013976  | Confirms the parameter value and switches to the next parameter. |
| <br>A0013977 | Opens the editing view of the parameter.                         |

 In the wizard view the meaning of the keys is indicated by the navigation symbol directly above the respective key (softkey functionality).



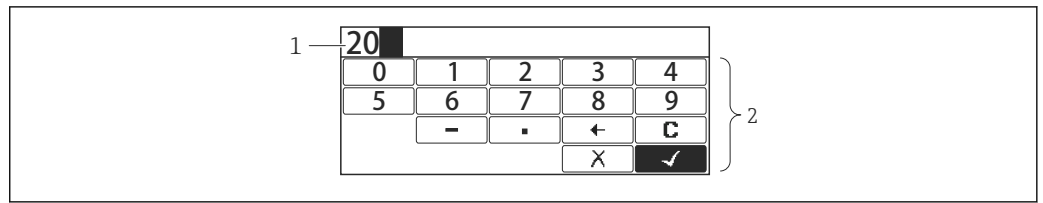



### 7.3.5 Numeric editor







A0028341

18 Numeric editor on the display module

- 1 Display area of the entered value
- 2 Input mask

| Symbol  | Meaning  |
|---|--|
|  <p>A0013998</p>   | Selection of numbers from 0 to 9.                  |
|  <p>A0016619</p>   | Inserts decimal separator at the input position.   |
|  <p>A0016620</p>   | Inserts minus sign at the input position.          |
|  <p>A0013985</p> | Confirms selection.                                |
|  <p>A0016621</p> | Moves the input position one position to the left. |
|  <p>A0013986</p> | Exits the input without applying the changes.      |
|  <p>A0014040</p> | Clears all entered characters.                     |

#### Meaning of the keys in the numeric editor

| Key   | Meaning  |
|---|--|
|  <p>A0028324</p> | <b>Minus key</b><br>In the input mask, moves the selection bar to the left (backwards).  |
|  <p>A0028325</p> | <b>Plus key</b><br>In the input mask, moves the selection bar to the right (forwards).   |
|  <p>A0028326</p> | <b>Enter key</b> <ul style="list-style-type: none"> <li>■ Pressing the key briefly adds the selected number to the current decimal place or carries out the selected action.</li> <li>■ Pressing the key for 2 s confirms the edited parameter value.</li> </ul> |
|  <p>A0028327</p> | <b>Escape key combination (press keys simultaneously)</b><br>Closes the text or numeric editor without applying changes.   |

### 7.3.6 Text editor

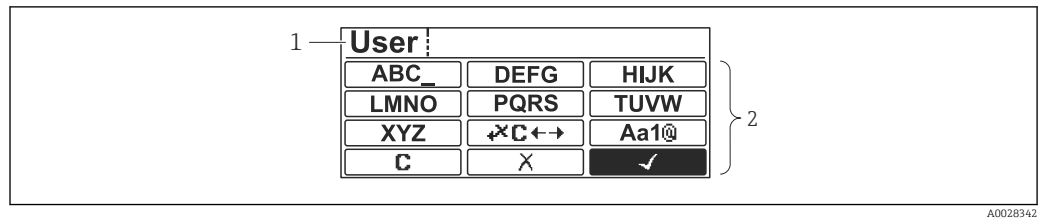

A0028342

19 Text editor on the display module

- 1 Display area of the entered text
- 2 Input mask





#### Text editor symbols

| Symbol                  | Meaning   |
|-------------------------|---|
| <br>...<br><br>A0013997 | Selection of letters from A to Z  |
| <br>A0013981            | Toggle <ul style="list-style-type: none"> <li>▪ Between upper-case and lower-case letters</li> <li>▪ For entering numbers</li> <li>▪ For entering special characters</li> </ul> |
| <br>A0013985            | Confirms selection.   |
| <br>A0013987            | Switches to the selection of the correction tools.  |
| <br>A0013986            | Exits the input without applying the changes.   |
| <br>A0014040            | Clears all entered characters.  |

#### Correction symbols under ✕C↔

|              |  |
|--------------|--|
| <br>A0013989 | Clears all entered characters.                                       |
| <br>A0013991 | Moves the input position one position to the right.                  |
| <br>A0013990 | Moves the input position one position to the left.                   |
| <br>A0013988 | Deletes one character immediately to the left of the input position. |

### Meaning of the keys in the text editor

| Key   | Meaning   |
|---|---|
| <br>A0028324 | <b>Minus key</b><br>In the input mask, moves the selection bar to the left (backwards).   |
| <br>A0028325 | <b>Plus key</b><br>In the input mask, moves the selection bar to the right (forwards).  |
| <br>A0028326 | <b>Enter key</b> <ul style="list-style-type: none"> <li>▪ Pressing the key briefly               <ul style="list-style-type: none"> <li>- Opens the selected group.</li> <li>- Carries out the selected action.</li> </ul> </li> <li>▪ Pressing the key for 2 s confirms the edited parameter value.</li> </ul> |
| <br>A0028327 | <b>Escape key combination (press keys simultaneously)</b><br>Closes the text or numeric editor without applying changes.  |

## 7.3.7 Keypad lock

### Automatic keypad lock

Operation via the local display is automatically locked:

- after a start-up or restart of the device.
- if the device has not been operated via the display for > 1 minute.



When attempting to access the operating menu while the keylock is enabled, the **Keylock on** message appears.

### Disabling the keypad lock

1. The keylock is enabled.  
 Press  for at least 2 seconds.  
 ↳ A context menu appears.
2. Select **Keylock off** from the context menu.  
 ↳ The keylock is disabled.

### Manual activation of the keypad lock

After commissioning of the device the keypad lock can be activated manually.

1. The device is in the measured value display.  
 Press  for at least 2 seconds.  
 ↳ A context menu appears.
2. Select **Keylock on** from the context menu.  
 ↳ The keylock is enabled.

## 7.3.8 Access code and user roles

### Meaning of the access code

An access code can be defined in order to distinguish between the following user roles:

| User role          | Definition  |
|--------------------|---|
| <b>Maintenance</b> | <ul style="list-style-type: none"> <li>▪ Knows the access code.</li> <li>▪ Has write access to all parameters (except service parameters).</li> </ul> |
| <b>Operator</b>    | <ul style="list-style-type: none"> <li>▪ Doesn't know the access code.</li> <li>▪ Has write access to only a few parameters.</li> </ul>               |



-  The description of parameters states which role is needed at least for read and write access to each parameter.
- The current user role is indicated by the **Access status display** parameter.
- If the access code is "0000", every user is in the **Maintenance** role. This is the default setting on delivery of the device.

### Defining an access code

1. Navigate to: Setup → Advanced setup → Administration → Define access code → Define access code
2. Enter the intended access code (max. 4 digits).
3. Repeat the same code in the **Confirm access code** parameter.
  - ↳ The user is in the **Operator** role. The -symbol appears in front of all write-protected parameters.

### Switching to the "Maintenance" role

If the -symbol appears on the local display in front of a parameter, the parameter is write-protected because the user is in the **Operator** role. To switch to the **Maintenance** role, proceed as follows:

1. Press .
  - ↳ The input prompt for the access code appears.
2. Enter the access code.
  - ↳ The user is in the **Maintenance** role. The -symbol in front of the parameters disappears; all previously write-protected parameters are now re-enabled.

### Switching back to the "Operator" role automatically

The user automatically switches back to the **Operator** role:

- if no key is pressed for 10 minutes in the navigation and editing mode.
- 60 s after going back from the navigation and editing mode to the standard view (measured value display).

### 7.3.9 Write protection switch

The operating menu can be locked by a hardware switch in the connection compartment. In this locking state W&M related parameters are read only.

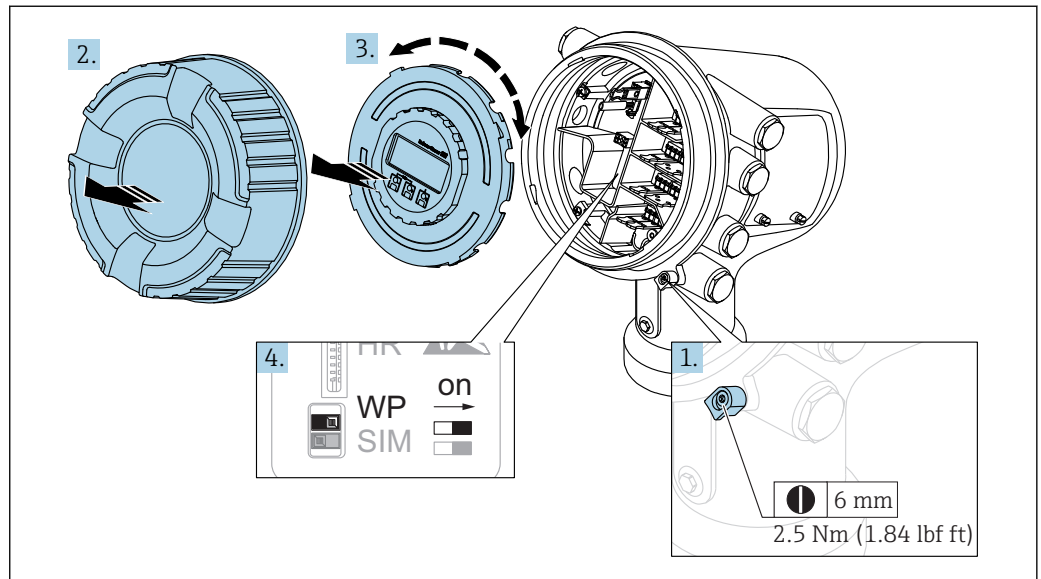

A0028363

1. Loosen the securing clamp.
2. Unscrew the housing cover.
3. Pull out the display module with a gentle rotation movement.
4. Using a flat blade screwdriver or a similar tool, set the write protection switch (**WP**) into the desired position. **ON**: operating menu is locked; **OFF**: operating menu is unlocked.
5. Put the display module onto the connection compartment, screw the cover closed and tighten the securing clamp.

**i** To avoid access to the write protection switch, the cover of the connection compartment can be secured by a lead seal.

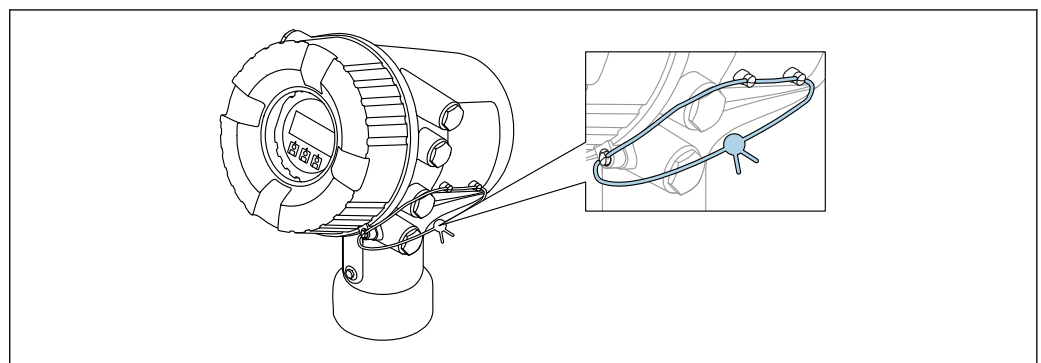

A0033363

**20** Sealing of the cover of the connection compartment

**i** The display module can be attached to the edge of the electronics compartment. This makes it easier to access the lock switch.

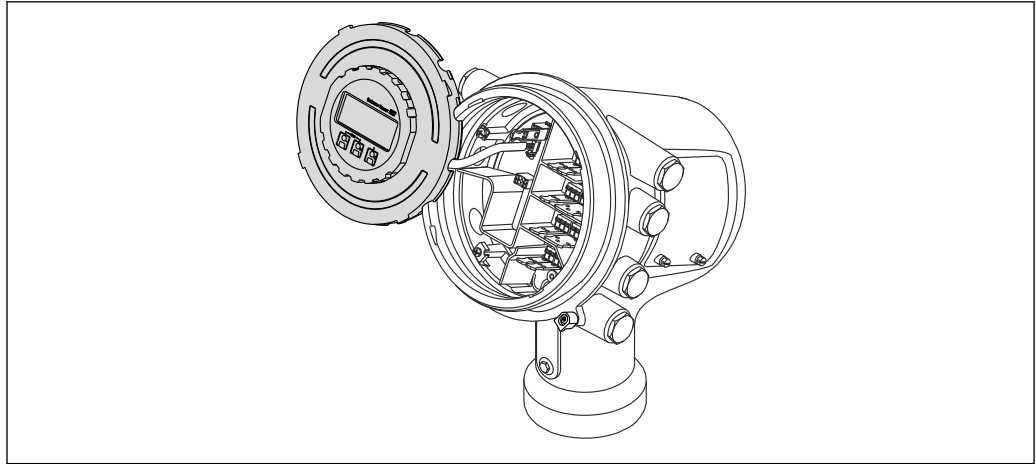

A0028381

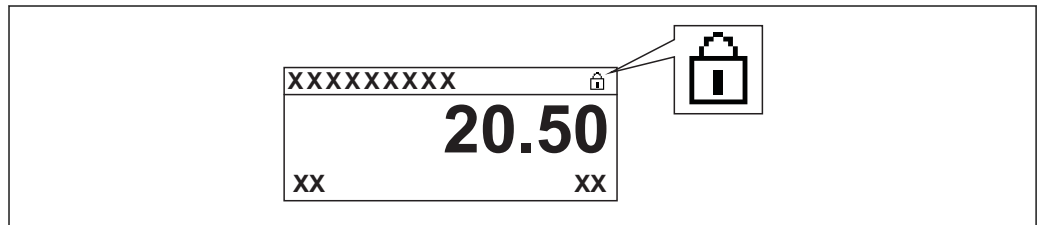

### Indication of the locking state



A0015870

 21 Write protection symbol in the header of the display

Write protection via locking switch is indicated as follows:

- **Locking status** (→  126) = **Hardware locked**
-  appears in the header of the display.



## 7.4 Access to the operating menu via the service interface and FieldCare

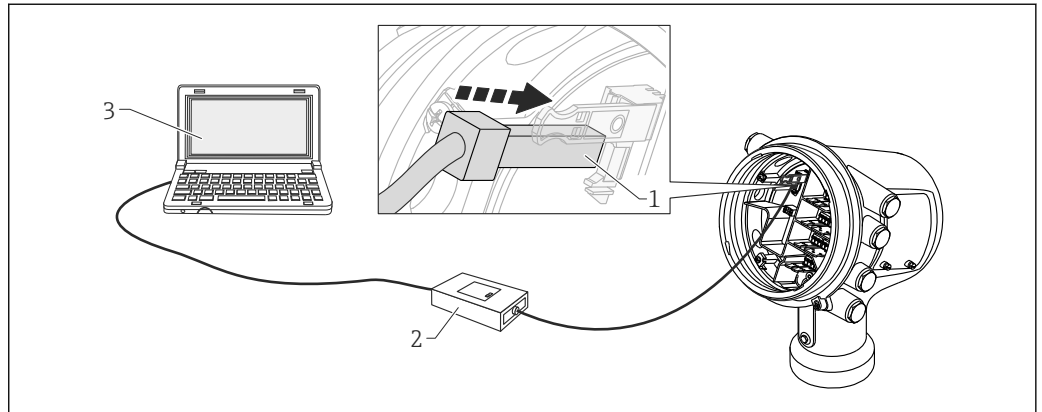

A0023737

22 Operation via service interface

- 1 Service interface (CDI = Endress+Hauser Common Data Interface)
- 2 Commubox FXA291
- 3 Computer with "FieldCare" operating tool and "CDI Communication FXA291" COM DTM

### The "Save/Restore" function

After a device configuration has been saved to a computer and restored to the device using the **Save/Restore** function of FieldCare, the device must be restarted by the following setting:

**Setup** → **Advanced setup** → **Administration** → **Device reset** = **Restart device**.

This ensures correct operation of the device after the restore.

## 7.5 Access to the operating menu via Tankvision Tank Scanner NXA820 and FieldCare

### 7.5.1 Wiring scheme

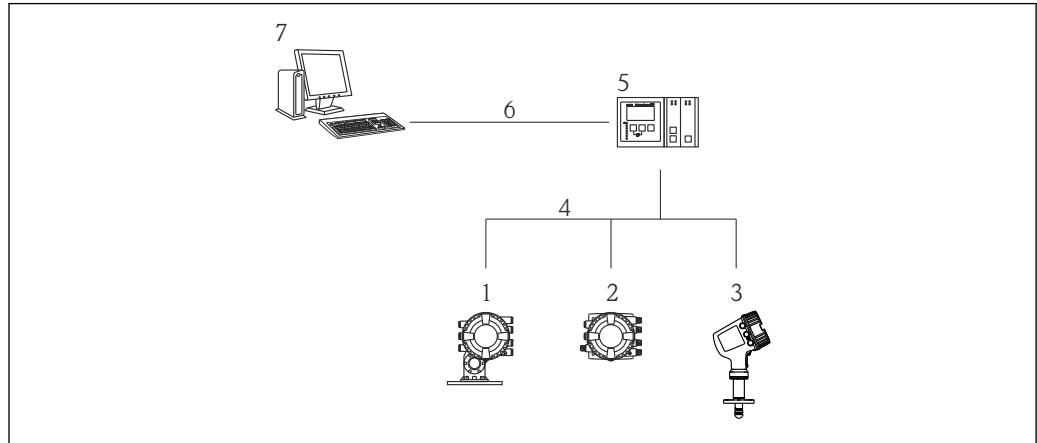

A0025621

23 Connection of Tank Gauging devices to FieldCare via the Tankvision Tank Scanner NXA820

- 1 Proservo NMS8x
- 2 Tankside Monitor NRF81
- 3 Micropilot NMR8x
- 4 Field protocol (e.g. Modbus, V1)
- 5 Tankvision Tank Scanner NXA820
- 6 Ethernet
- 7 Computer with FieldCare installed

### 7.5.2 Establishing the connection between FieldCare and the device

1. Make sure the **HART CommDTM NXA** is installed and update the DTM catalogue if required.
2. Create a new project in FieldCare.
- 3.

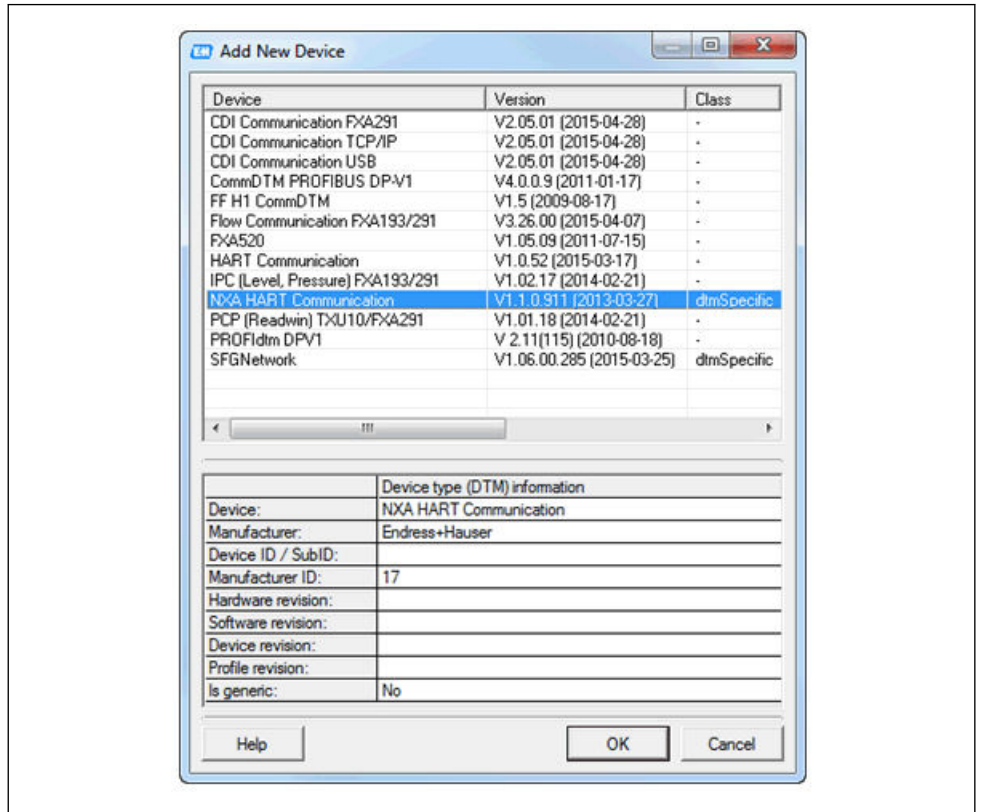

A0028515

Add a new device: **NXA HART Communication**

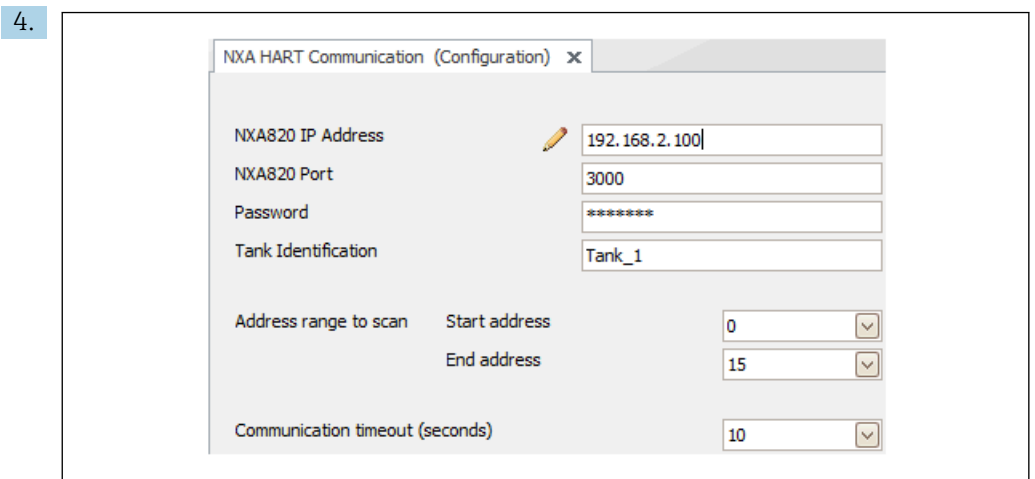

A0028516

Open the configuration of the DTM and enter the required data (IP address of the NXA820; "Password" = "hart"; "Tank identification" only with NXA V1.05 or higher)

5.

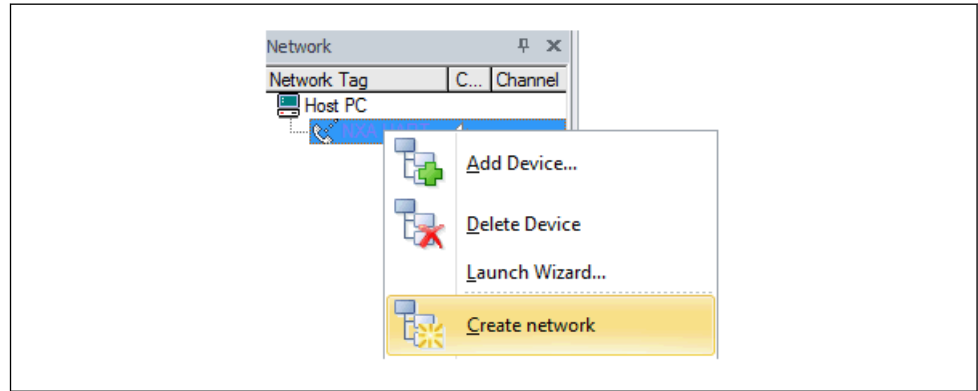

A0028517

Select **Create network** from the context menu.

↳ The device is detected and the DTM is assigned.

6.

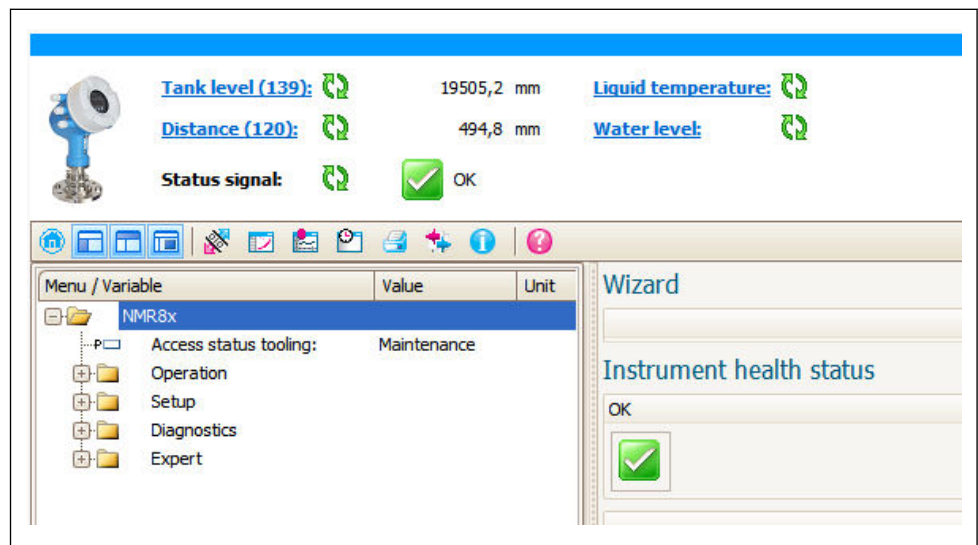

A0032933

↳ The device can be configured.

### **i** The "Save/Restore" function

After a device configuration has been saved to a computer and restored to the device using the **Save/Restore** function of FieldCare, the device must be restarted by the following setting:

**Setup** → **Advanced setup** → **Administration** → **Device reset = Restart device**.

This ensures correct operation of the device after the restore.

## 8 System integration

### 8.1 Overview of the Device Description files (DTM)

To integrate the device via HART into FieldCare, a Device Description file (DTM) according to the following specification is required:

|                     |  |
|---------------------|--|
| Manufacturer ID     | 0x11   |
| Device type (NMR8x) | 0x112E   |
| HART specification  | 7.0  |
| DD files            | For information and files see:<br><a href="http://www.endress.com">www.endress.com</a> |

## 9 Commissioning

### 9.1 Terms related to tank measurement

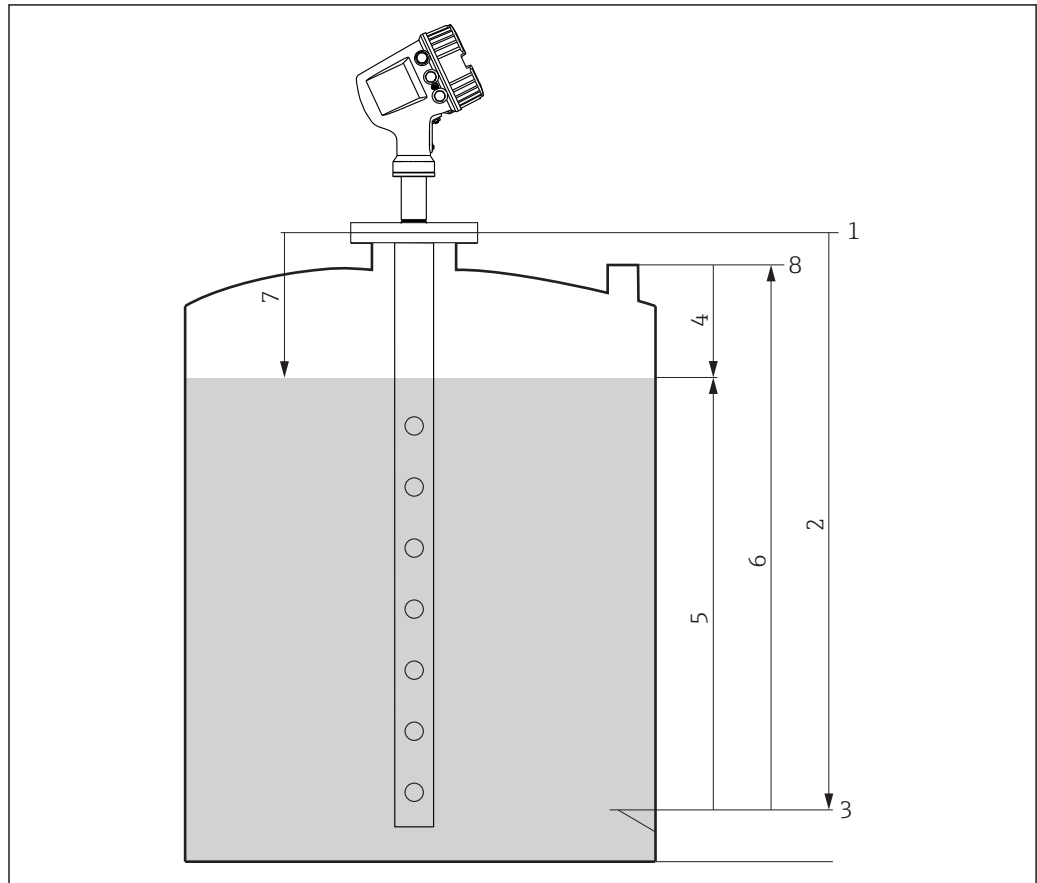

A0029801

24 Terms related to radar tank measurement

- 1 Gauge reference height
- 2 Empty
- 3 Datum plate
- 4 Tank ullage
- 5 Tank level
- 6 Tank reference height
- 7 Distance
- 8 Dipping reference

## 9.2 Initial settings

### 9.2.1 Setting the display language

#### Setting the display language via the display module

1. While in the standard view (→ 38), press "E". If required, select **Keylock off** from the context menu and press "E" again.
  - ↳ The **Language** parameter appears.
2. Open the **Language** parameter and select the display language.

#### Setting the display language via an operating tool (e.g. FieldCare)

1. Navigate to: Setup → Advanced setup → Display → Language

2. Select the display language.

**i** This setting only affects the language on the display module. To set the language in the operating tool use the language setting functionality of FieldCare or DeviceCare, respectively.

## 9.2.2 Setting the real-time clock

### Setting the real-time clock via the display module

1. Navigate to: Setup → Advanced setup → Date / time → Set date
2. Use the following parameters to set the the real-time clock to the current date and time: **Year, Month, Day, Hour, Minutes.**

### Setting the real-time clock via an operating tool (e.g. FieldCare)

1. Navigate to: Setup → Advanced setup → Date / time
- 2.

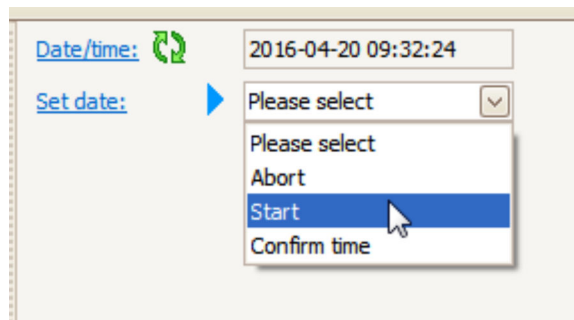



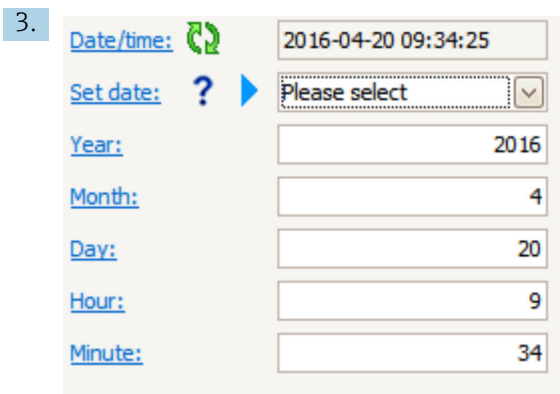

Go to the **Set date** parameter and select the **Start** option.



Use the following parameters to set the date and time: **Year, Month, Day, Hour, Minutes.**

4.

|                            |   |   |
|----------------------------|---|---|
| <a href="#">Date/time:</a> |    | 2016-04-20 09:35:49   |
| <a href="#">Set date:</a>  |   | Please select  |
| <a href="#">Year:</a>      |   | Please select   |
| <a href="#">Month:</a>     |   | Abort   |
| <a href="#">Day:</a>       |   | Start   |
| <a href="#">Hour:</a>      |   | 9   |
| <a href="#">Minute:</a>    |   | 34  |

The image shows a screenshot of a web-based configuration interface. On the left, there are several parameters: 'Date/time' with a refresh icon, 'Set date' with a help icon and a blue arrow, 'Year:', 'Month:', 'Day:', 'Hour:', and 'Minute:'. The 'Date/time' field displays '2016-04-20 09:35:49'. The 'Set date' field is open, showing a dropdown menu with options: 'Please select', 'Abort', 'Start', and 'Confirm time'. A mouse cursor is pointing at the 'Confirm time' option. The 'Hour' and 'Minute' fields are input boxes containing the values '9' and '34' respectively.

Go to the **Set date** parameter and select the **Confirm time** option.

↳ The real-time clock is set to the current date and time.









## 9.3 Configuring the measuring device

### 9.3.1 Configuration of the level measurement

The first parameters of the **Setup** menu are used to configure the measurement. A short description is given in the following sections. For a more detailed description refer to the parameter description in the appendix →  120.

#### Basic settings



Navigation path: Setup

| Parameter             | Meaning  | Description   |
|-----------------------|--|---|
| Setup → Device tag    | Define a name to identify the measuring point within the plant.  | →  120 |
| Setup → Units preset  | Select a set of units for length, pressure and temperature.  | →  120 |
| Setup → Tube diameter | Enter the diameter of the stilling well.   | →  219 |
| Setup → Empty         | Enter the distance from the lower edge of the device flange to the datum plate.  | →  121 |
| Setup → Tank level    | Shows the measured level.<br>Check whether the indicated value matches the actual level.   | →  111 |
| Setup → Set level     | Can be used to correct a constant shift of the measured level.<br>If the indicated level does not match the actual level: Enter the actual level into this parameter.<br>An offset for the measured level is then automatically defined. | →  122 |

 The **Set level** parameter can only be used to compensate for a constant level error. To eliminate errors resulting from interference echos, use the interference echo suppression (map).

#### Interference echo suppression (map) in an operating tool (e.g. FieldCare/DeviceCare)

Navigation path: Setup

| Parameter                 | Meaning   | Description   |
|---------------------------|---|---|
| Setup → Distance          | Shows the measured distance from the lower edge of the device flange to the product surface. Check whether this value is correct.   | →  125 |
| Setup → Confirm distance  | Specify whether the measured distance matches the actual distance. The selection determines up to which distance an interference echo suppression is recorded.  | →  122 |
| Present mapping           | Shows up to which distance a mapping has already been recorded.   |   |
| Setup → Mapping end point | Only visible for <b>Confirm distance = Manual map</b> .<br>Determines up to which distance the new mapping will be recorded.<br>Depending on the selection in <b>Confirm distance</b> a suitable value is preset in this parameter. Usually, there is no need to change this value. |   |
| Setup → Record map        | Only visible for <b>Confirm distance = Manual map</b><br>Select <b>Record map</b> . This starts the recording of the new map.   | →  124 |

#### Interference echo suppression on the local display

Navigation path: Setup → Mapping

















 For the meaning of the parameters in this wizard see the table above.

**Dip table**

The dip table is used to correct the level readings using independently taken hand dips. The dip table is used in particular to adapt the level gauge to the specific application conditions such as a mechanical offset and the tank or stilling well design.

The dip table is managed in the **Dip-table** submenu →  204.

## 9.4 Configuring the tank gauging application

| Configuration of the inputs:  | Description  |
|---|--|
| HART inputs   | →  60   |
| NMT532/539 connected via HART   | →  62   |
| 4-20mA inputs   | →  63   |
| RTD input   | →  64   |
| Digital inputs  | →  66   |
| Configuration of the data processing in the device:                     | Description  |
| Linking input values to tank variables                                  | →  68   |
| Tank calculation: Direct Level Measurement                              | →  69   |
| Tank calculation: Hybrid Tank Measurement System (HTMS)                 | →  70   |
| Tank calculation: Correction of the Hydrostatic Tank Deformation (HyTD) | →  71   |
| Tank calculation: Thermal Tank Shell Correction (CTSh)                  | →  72   |
| Alarms (limit evaluation)   | →  73   |
| Configuration of the signal output:                                     | Description  |
| 4-20mA output   | →  74   |
| HART slave + 4-20mA output  | →  75  |
| Modbus  | →  77 |
| V1  | →  78 |
| Digital outputs   | →  79 |

## 9.4.1 Configuration of the HART inputs

### Connecting and addressing HART devices

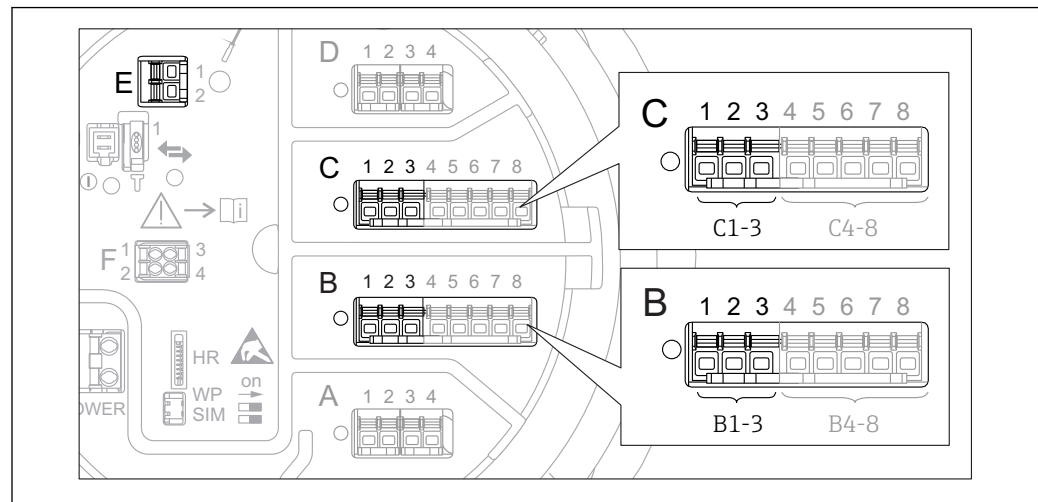

A0032955

25 Possible terminals for HART loops

- B Analog I/O module in slot B (availability depending on device version → 21)
- C Analog I/O module in slot C (availability depending on device version → 21)
- E HART Ex is output (available in all device versions)

**i** HART devices must be configured and given a unique HART address in the range from 1 to 15 via their own user interface before they are connected to the Micropilot NMR8x<sup>2)</sup>. Make sure they are connected as defined by the terminal assignment → 27. Devices with an address larger than 15 are not recognized by the Micropilot.

#### Slot B or C: Setting the operating mode of the Analog I/O module



**i** This section is not relevant for the HART Ex is output (Slot E). This output always functions as a HART master for the connected HART slaves.

If HART devices are connected to an Analog I/O module (slot B or C in the terminal compartment), this module must be configured as follows:





1. Navigate to the submenu of the respective Analog I/O module: Setup → Advanced setup → Input/output → Analog I/O X1-3
2. Go to the **Operating mode** parameter (→ 140).
3. If only one HART device is connected to this loop:  
Select the **HART master+4..20mA input** option. In this case the 4-20mA signal can be used in addition to the HART signal. For the configuration of the 4-20mA input: → 63.
4. If up to 6 HART devices are connected to this loop:  
Select the **HART master** option.

2) The current software does not support HART devices with address 0 (zero).

### Defining the type of measured value

-  This setting can be skipped for a connected Prothermo NMT5xx as the type of measured value is automatically recognized by the Micropilot NMR8x in this case.
- 
  - The measured values can only be used in the system if the unit of the assigned HART variable fits the type of measured value. The HART variable assigned to **Output temperature**, for example, has to be in °C or °F.
  - A HART variable with unit "%" can not be used for **Output level**. Instead, the HART variable must be in mm, m, ft or in.

The type of measured value must be specified for each HART variable (PV, SV, TV and QV). To do so, proceed as follows:

1. Navigate to: Setup → Advanced setup → Input/output → HART devices
  - ↳ There is a submenu for each connected HART device.
2. For each device go to the corresponding submenu.
3. If the device measures a pressure:
  - Go to the **Output pressure** parameter (→  130) and specify which of the four HART variables contains the measured pressure. Only a HART variable with a pressure unit may be selected.
4. If the device measures a density:
  - Go to the **Output density** parameter (→  131) and specify which of the four HART variables contains the measured density. Only a HART variable with a density unit may be selected.
5. If the device measures a temperature:
  - Go to the **Output temperature** parameter (→  131) and specify which of the four HART variables contains the measured temperature. Only a HART variable with a temperature unit may be selected.
6. If the device measures the vapor temperature:
  - Go to the **Output vapor temperature** parameter (→  132) and specify which of the four HART variables contains the measured vapor temperature. Only a HART variable with a temperature unit may be selected.
7. If the device measures a level:
  - Go to the **Output level** parameter (→  132) and specify which of the four HART variables contains the measured level. Only a HART variable with a level unit (not "%") may be selected.

### Disconnecting HART devices

When a HART device is disconnected from the device, it must also be logically removed as follows:

1. Navigate to Setup → Advanced setup → Input/output → HART devices → Forget device → Forget device
2. Select the HART device to be removed.

-  This procedure is also necessary if a defective device is exchanged.

### 9.4.2 Configuration of a connected Prothermo NMT532/NMT539

If a Prothermo NMT532 or NMT539 temperature transmitter is connected via HART, it can be configured as follows:

1. Navigate to: Expert → Input/output → HART devices → HART Device(s) → NMT device config; here, **HART Device(s)** is the name of the connected Prothermo.
2. Go to the **Configure device?** parameter and select **Yes**.
3. Go to the **Bottom point** parameter and enter the position of the bottom temperature element (see picture below).

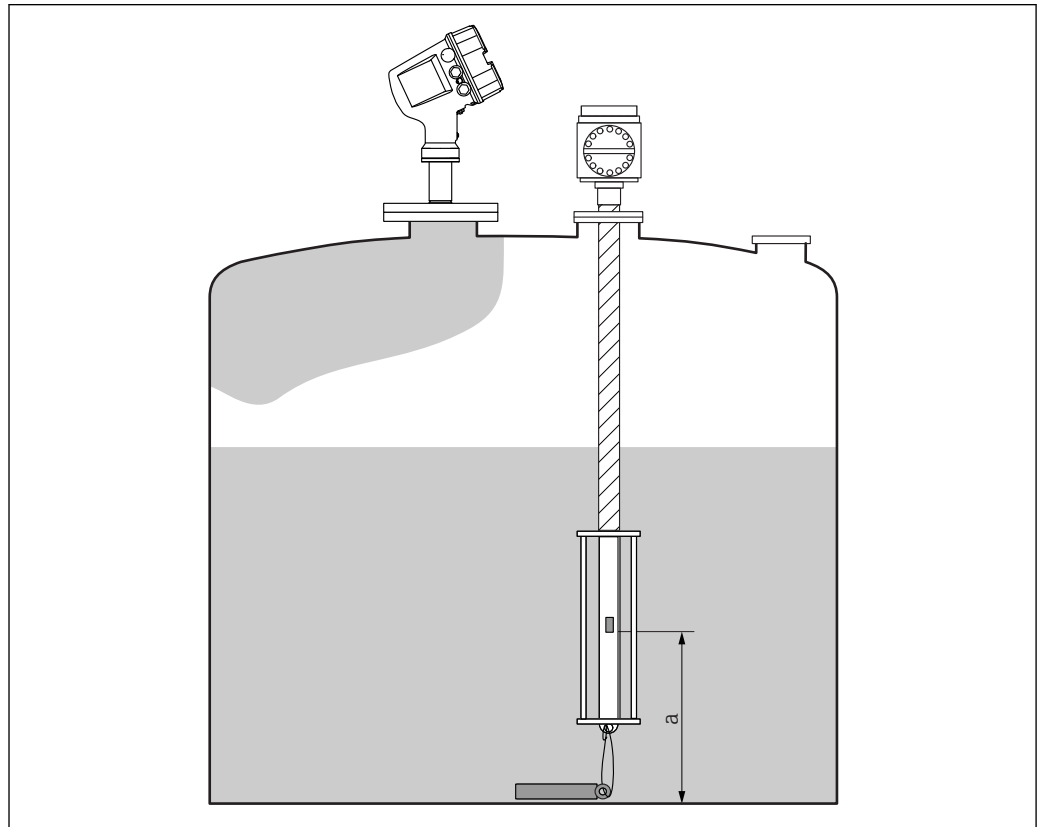

 26 Position of the bottom temperature element

*a* Distance from bottom temperature element to zero reference (tank bottom or datum plate). The standard factory default setting is 500 mm (19.69 in), and it can be adjusted according to the actual installation.

-  To check the temperatures measured by the individual elements, go to the following submenu: Operation → Temperature → NMT element values → Element temperature
- There is a **Element temperature X** parameter for each element of the Prothermo.

### 9.4.3 Configuration of the 4-20mA inputs

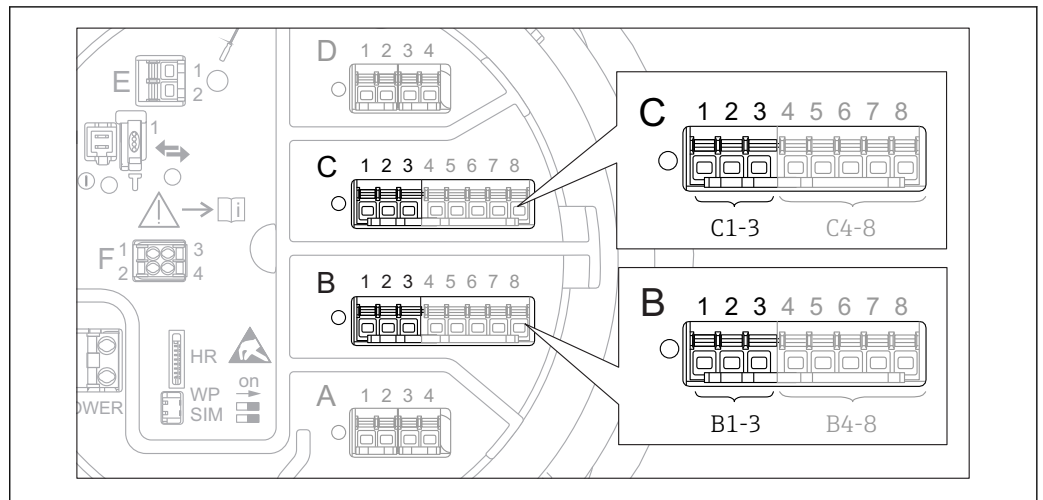

27 Possible locations of the Analog I/O modules, which can be used as a 4-20mA input. The order code of the device determines which of these modules is actually present → 21.

For each Analog I/O module to which a 4-20mA device is connected, proceed as follows:

1. Make sure the 4-20mA devices are connected as defined by the terminal assignment → 27.
2. Navigate to the submenu of the respective Analog I/O module: Setup → Advanced setup → Input/output → Analog I/O X1-3
3. Go to the **Operating mode** parameter (→ 140) and select **4..20mA input** or **HART master+4..20mA input**.
4. Go to the **Process variable** parameter (→ 146) and specify which process variable is transmitted by the connected device.
5. Go to the **Analog input 0% value** parameter (→ 146) and define which value of the process variable corresponds to an input current of 4 mA (see diagram below).
6. Go to the **Analog input 100% value** parameter (→ 146) and define which value of the process variable corresponds to an input current of 20 mA (see diagram below).
7. Go to the **Process value** parameter (→ 147) and check whether the indicated value matches the actual value of the process variable.

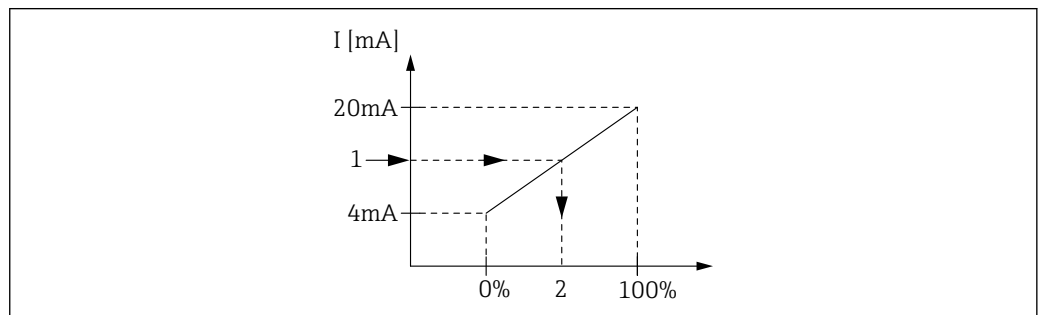

28 Scaling of the 4-20mA input to the process variable

- 1 Input value in mA
- 2 Process value

**i** The **Analog I/O** submenu contains additional parameters for a more detailed configuration of the Analog Input. For a description refer to : → 140

### 9.4.4 Configuration of a connected RTD

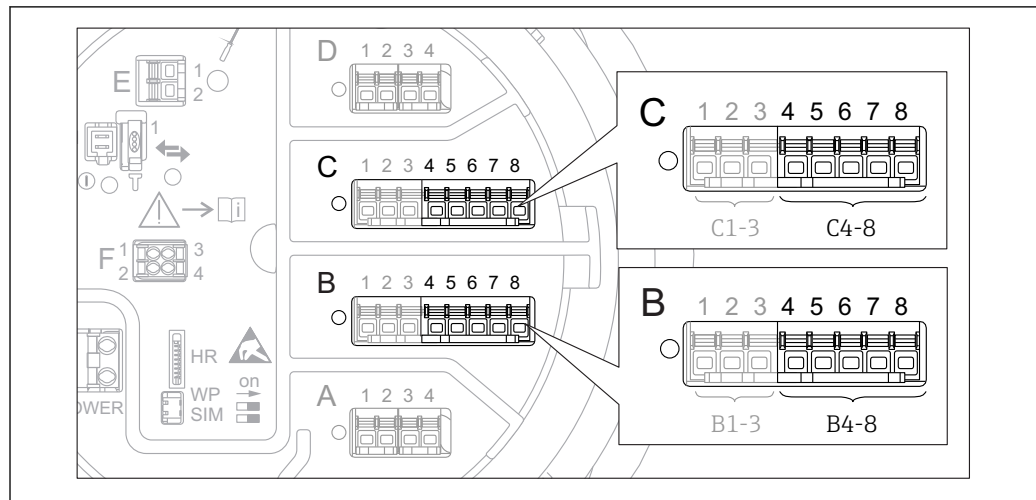

A0032465

29 Possible locations of the Analog I/O modules, to which an RTD can be connected. The order code of the device determines which of these modules is actually present → 21.

1. Make sure the RTD is connected as defined by the terminal assignment → 31.
2. Navigate to the submenu of the respective Analog I/O module: Setup → Advanced setup → Input/output → Analog IP X4-8.
3. Go to the **RTD type** parameter (→ 134) and specify the type of the connected RTD.

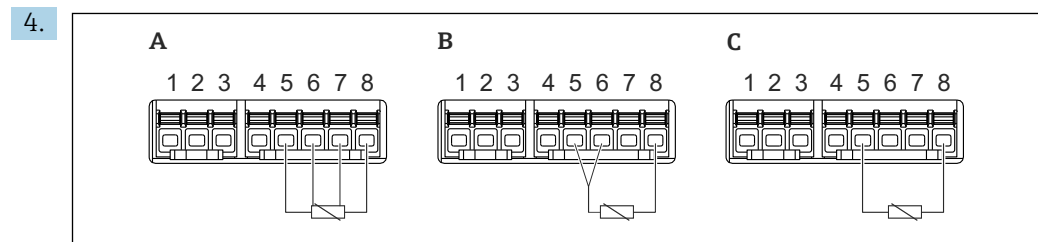

A0026371

30 RTD connection types

- A 2 wire RTD connection
- B 3 wire RTD connection
- C 4 wire RTD connection

Go to the **RTD connection type** parameter (→ 135) and specify the type of connection of the RTD (2-, 3- or 4-wire).

5. Go to the **Input value** parameter (→ 137) and check whether the indicated temperature matches the actual temperature.
6. Go to the **Minimum probe temperature** parameter (→ 137) and specify the minimum approved temperature of the connected RTD.
7. Go to the **Maximum probe temperature** parameter (→ 137) and specify the maximum approved temperature of the connected RTD.



8.

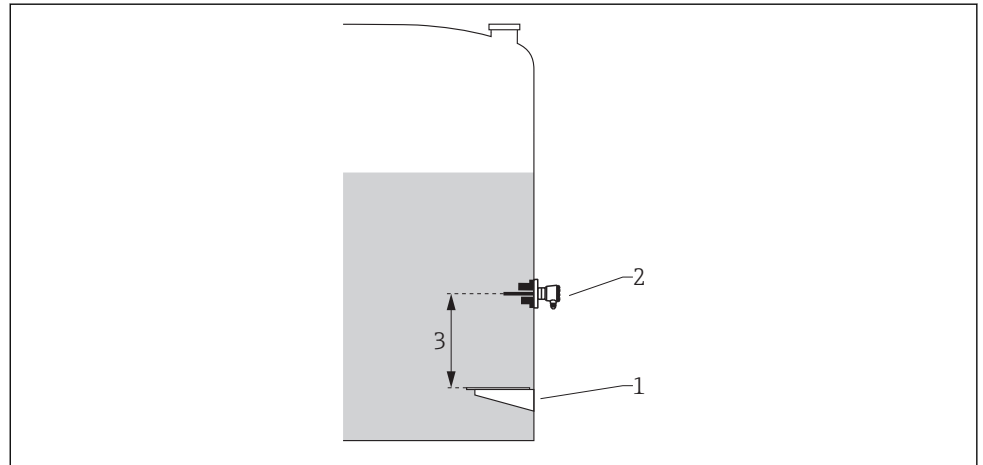

A0029269

- 1 Datum plate
- 2 RTD
- 3 Probe position ( $\rightarrow$  [138](#))

Go to the **Probe position** parameter and enter the mounting position of the RTD (measured from the datum plate).

$\hookrightarrow$  This parameter, in conjunction with the measured level, determines whether the measured temperature refers to the product or to the gas phase.

### Offset for resistance and/or temperature



An offset for the resistance or the temperature can be defined in the following submenu: Expert  $\rightarrow$  Input/output  $\rightarrow$  Analog IP X4-8.

- **Ohms offset** is added to the measured resistance before the calculation of the temperature.
- **Temperature offset after conversion** is added to the measured temperature.

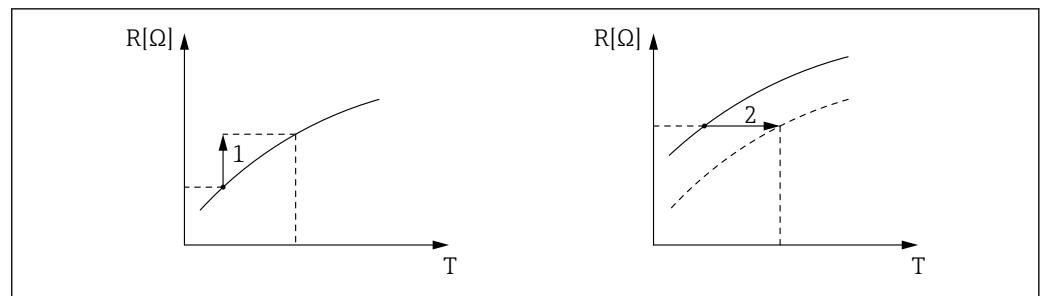

A0029265

- 1 Ohms offset
- 2 Temperature offset after conversion

### 9.4.5 Configuration of the digital inputs

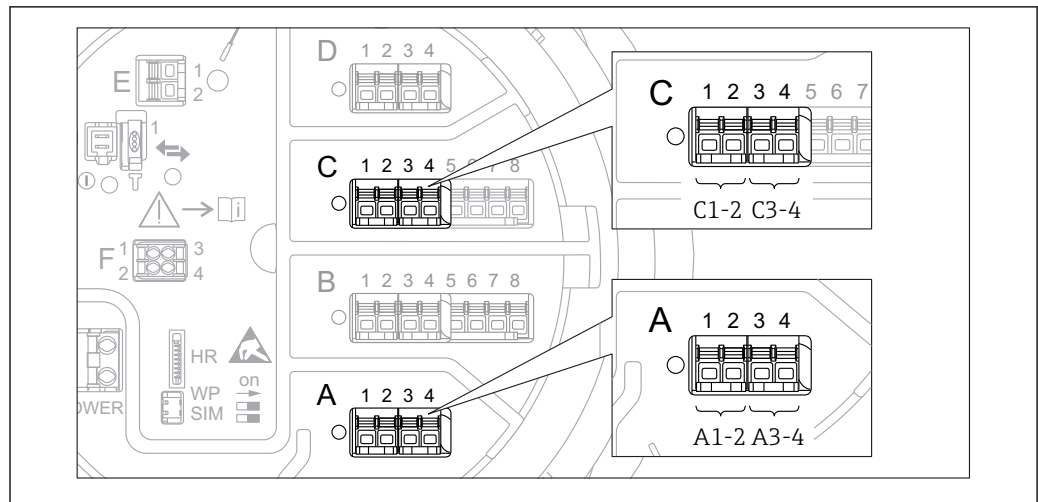

31 Possible locations of the Digital I/O modules (examples); the order code defines the number and location of digital input modules → 21.

There is a **Digital Xx-x** submenu for each digital I/O module of the device. "X" designates the slot in the terminal compartment, "x-x" the terminals within this slot. The most important parameters of this submenu are **Operating mode** and **Contact type**.

#### The "Operating mode" parameter

Setup → Advanced setup → Input/output → Digital Xx-x → Operating mode

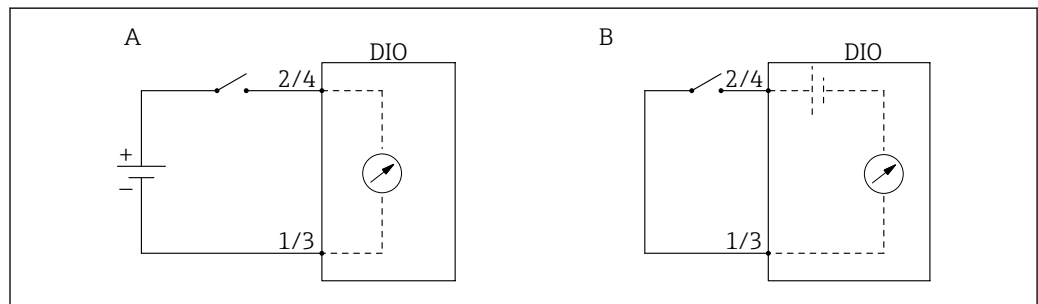

A "Operating mode" = "Input passive"  
 B "Operating mode" = "Input active"

#### Meaning of the options

- **Input passive**

The DIO module measures the voltage provided by an external source. Depending on the status of the external switch, this voltage is 0 at the input (switch open) or exceeds a certain limit voltage (switch closed). These two states represent the digital signal.

- **Input active**



The DIO module provides a voltage and uses it to detect whether the external switch is open or closed.

#### The "Contact type" parameter

Setup → Advanced setup → Input/output → Digital Xx-x → Contact type

This parameter determines how the state of the external switch is mapped to the internal states of the DIO module:

| State of the external switch           | Internal state of the DIO module |                                |
|--|----------------------------------|--------------------------------|
|  | Contact type = Normally open     | Contact type = Normally closed |
| Open                                   | Inactive                         | Active                         |
| Closed                                 | Active                           | Inactive                       |
| <b>Behavior in special situations:</b> |                                  |                                |
| During start-up                        | Unknown                          | Unknown                        |
| Fault in measurement                   | Error                            | Error                          |

- 
 The internal state of the Digital Input can be transferred to a Digital Output or can be used to control the measurement.
- The **Digital Xx-x** submenu contains additional parameters for a more detailed configuration of the Digital Input. For a description refer to →  150.

### 9.4.6 Linking input values to tank variables

Measured values must be linked to tank variables before they can be used in the Tank Gauging application. This is done by defining the source of each tank variable in the following parameters:

| Tank variable                               | Parameter defining the source of this variable   |
|---|--|
| Bottom water level                          | Setup → Advanced setup → Application → Tank configuration → Level → Water level source   |
| Average or spot temperature of the product  | <ul style="list-style-type: none"> <li>■ Setup → Liquid temp source</li> <li>■ Setup → Advanced setup → Application → Tank configuration → Temperature → Liquid temp source</li> </ul> |
| Temperature of the air surrounding the tank | Setup → Advanced setup → Application → Tank configuration → Temperature → Air temperature source   |
| Temperature of the vapor above the product  | Setup → Advanced setup → Tank configuration → Temperature → Vapor temp source  |
| Density of the product                      | Setup → Advanced setup → Application → Tank configuration → Density → Observed density source  |
| Bottom pressure (P1)                        | Setup → Advanced setup → Application → Tank configuration → Pressure → P1 (bottom) source  |
| Top pressure (P3)                           | Setup → Advanced setup → Application → Tank configuration → Pressure → P3 (top) source   |

 Depending on the application not all these parameters will be relevant in a given situation.

 The product level is always the level measured by the Micropilot itself. It needs not to be linked.

### 9.4.7 Tank calculation: Direct level measurement

If no tank calculation is configured, level and temperature are measured directly.

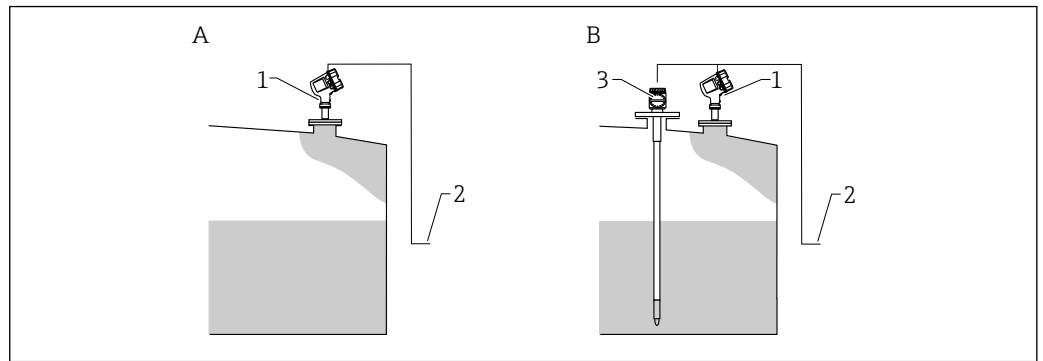

A0029255

- A Direct level measurement (without temperature)
- B Direct level and temperature measurement
- 1 Level transmitter
- 2 To inventory management system
- 3 Temperature transmitter

- ▶ If a temperature transmitter is connected:  
Navigate to: "Setup → Liquid temp source" and specify from which device the temperature is obtained.

### 9.4.8 Tank calculation: Hybrid tank measurement system (HTMS)

HTMS uses level and pressure measurements to calculate the density of the medium.

**i** In non-atmospheric (i.e. pressurized) tanks it is recommended to use the **HTMS P1+P3** mode. Two pressure sensors are required in this case. In atmospheric (i.e. unpressurized) tanks the **HTMS P1** with only one pressure sensor is sufficient.

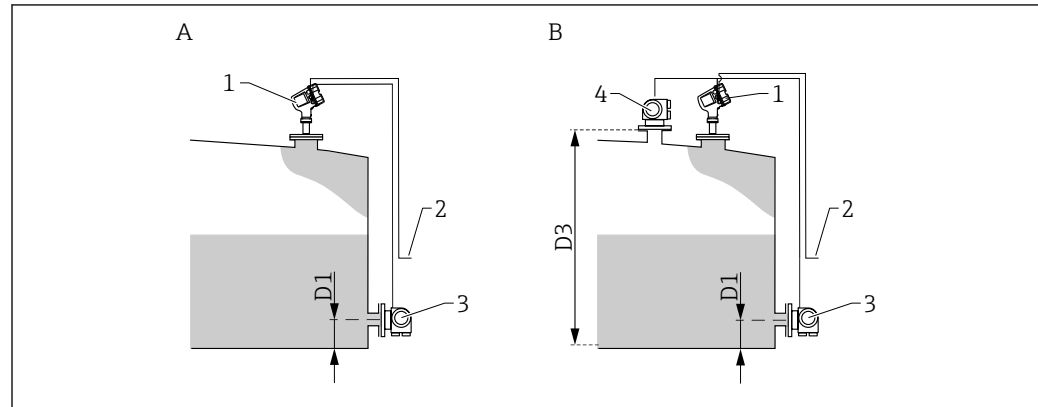

A0029256

A "HTMS mode" parameter" = "HTMS P1" option"

B "HTMS mode" parameter" = "HTMS P1+P3" option"

D1 P1 position

D3 P3 position

1 Micropilot

2 To inventory management system

3 Pressure sensor (bottom)

4 Pressure sensor (top)

1. Navigate to Setup → Advanced setup → Application → Tank configuration → Pressure
2. Go to **P1 (bottom) source** (→ 📖 183) and specify from which device the bottom pressure (P1) is obtained.
3. If a top pressure transmitter (P3) is connected:  
Go to **P3 (top) source** (→ 📖 185) and specify from which device the bottom pressure (P1) is obtained.
4. Navigate to: Setup → Advanced setup → Application → Tank calculation → HTMS
5. Go to **HTMS mode** (→ 📖 200) and specify the HTMS mode.
6. Navigate to Setup → Advanced setup → Application → Tank configuration → Density
7. Go to **Observed density source** (→ 📖 181) and select **HTMS**.
8. Use the other parameters of the **HTMS** submenu to configure the calculation. For a detailed description: → 📖 198

### 9.4.9 Tank calculation: Hydrostatic Tank Deformation (HyTD)

Hydrostatic Tank Deformation can be used to compensate the vertical movement of the Gauge Reference Height (GRH) due to bulging of the tank shell caused by the hydrostatic pressure exerted by the liquid stored in the tank. The compensation is based on a linear approximation obtained from manual hand dips at several levels divided over the full range of the tank.

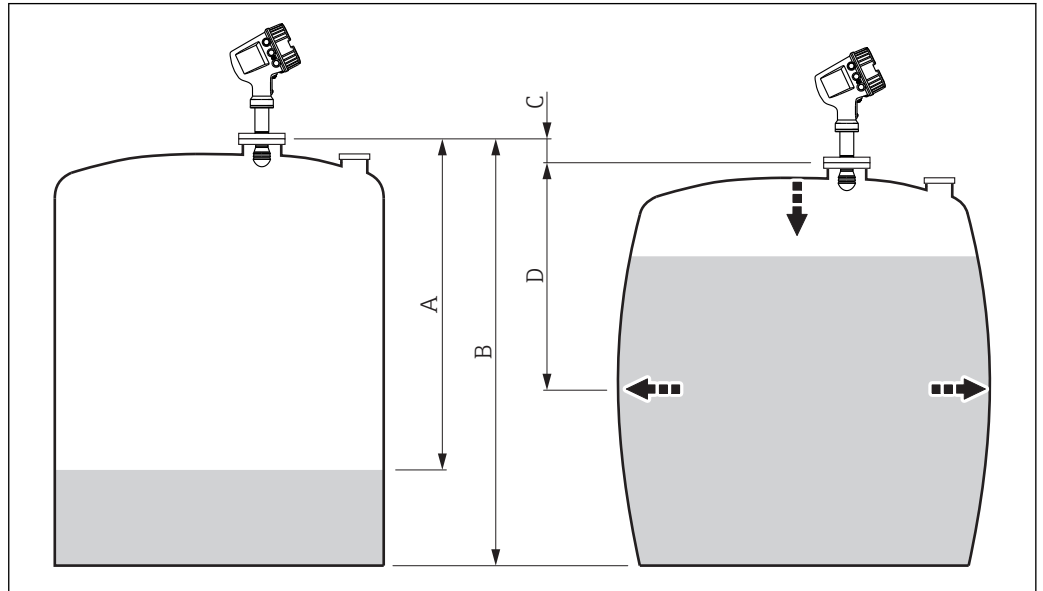

A0028722



32 Correction of the hydrostatic tank deformation (HyTD)

- A "Distance" (tank nearly empty)
- B Gauge Reference Height (GRH)
- C HyTD correction value
- D "Distance" (tank filled)

 The Correction of the Hydrostatic Tank Deformation is configured in the **HyTD** submenu (→  190)

### 9.4.10 Tank calculation: Thermal tank shell correction (CTSh)

CTSh (correction for the thermal expansion of the tank shell) compensates for effects on the Gauge Reference Height (GRH) and on the expansion or contraction of the measuring wire due to temperature effects on the tank shell or stilling well. The temperature effects are separated into two parts, respectively affecting the 'dry' and 'wetted' part of the tank shell or stilling well. The correction function is based on thermal expansion coefficients of steel and insulation factors for both the 'dry' and 'wet' parts of the wire and the tank shell. The temperatures used for the correction can be selected from on manual or measured values.

-  This correction is recommended for the following situations:
  - if the operating temperature deviates considerably from the temperature during calibration ( $\Delta T > 10\text{ }^{\circ}\text{C}$  (18 °F))
  - for extremely high tanks
  - for refrigerated, cryogenic or heated applications
-  As the use of this correction will influence the innage level reading, it is recommended to ensure the manual hand dip and level verification procedures are being conducted correctly before enabling this correction method.
-  This mode cannot be used in conjunction with HTG because the level is not measured relative to the gauge reference height with HTG.



### 9.4.11 Configuration of the alarms (limit evaluation)

A limit evaluation can be configured for up to 4 tank variables. The limit evaluation issues an alarm if the value exceeds an upper limit or falls below a lower limit, respectively. The limit values can be defined by the user.

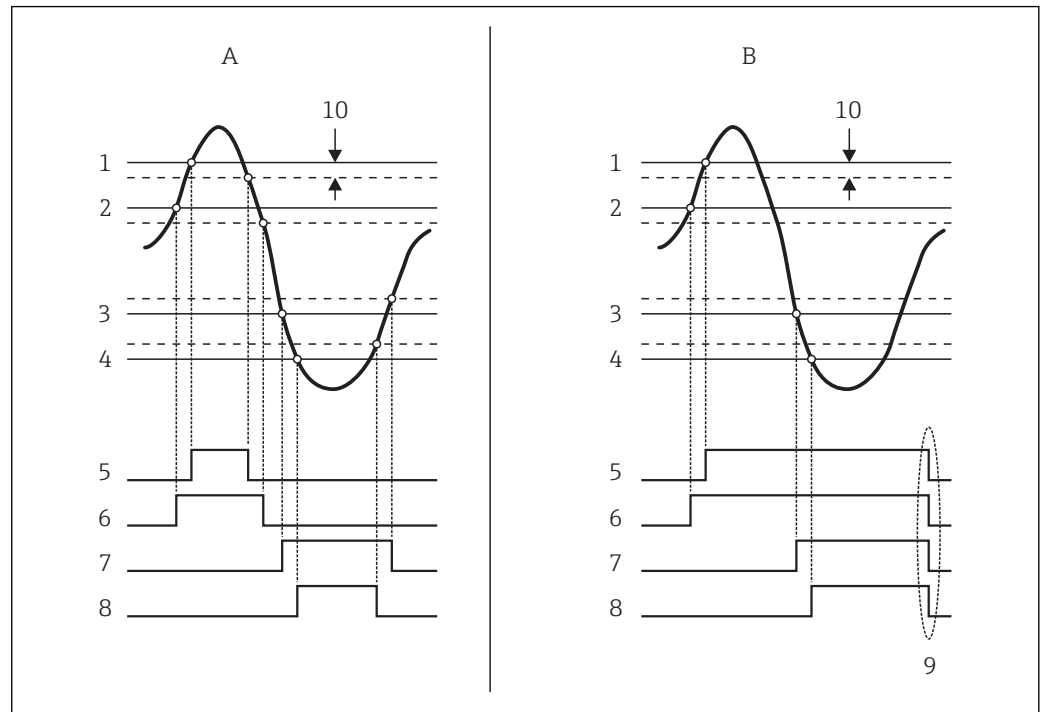

33 Principle of the limit evaluation

- A Alarm mode = On
- B Alarm mode = Latching
- 1 HH alarm value
- 2 H alarm value
- 3 L alarm value
- 4 LL alarm value
- 5 HH alarm
- 6 H alarm
- 7 L alarm
- 8 LL alarm
- 9 "Clear alarm" = "Yes" or power off-on
- 10 Hysteresis

The limit evaluation is configured in the **Alarm 1 to 4** submenus.

Navigation path: Setup → Advanced setup → Alarm → Alarm 1 to 4

**i** For **Alarm mode = Latching** all alarms remain active until the user selects **Clear alarm = Yes** or the power is switched off and on.

### 9.4.12 Configuration of the 4-20mA output

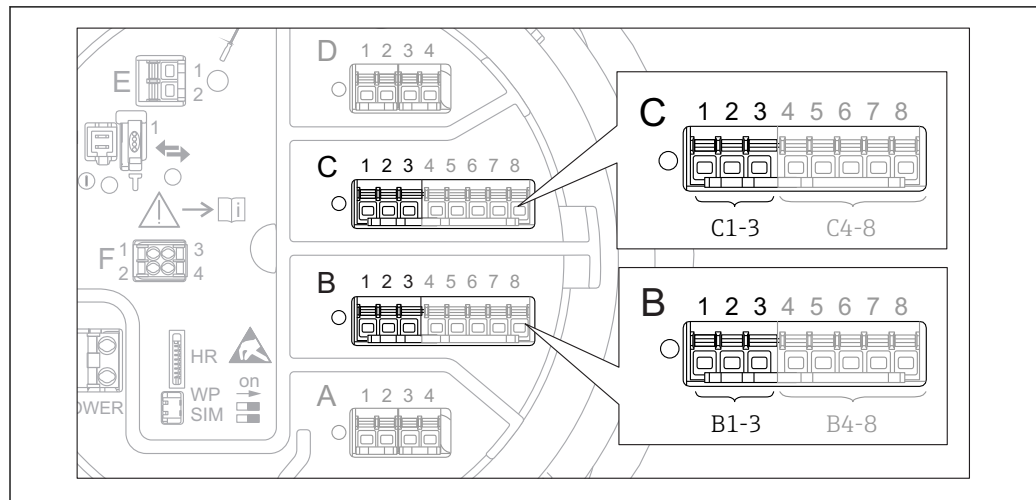

34 Possible locations of the Analog I/O modules, which can be used as a 4-20mA output. The order code of the device determines which of these modules is actually present → 21.

Each Analog I/O module of the device can be configured as a 4...20mA analog output. To do so, proceed as follows:

1. Navigate to: Setup → Advanced setup → Input/output → Analog I/O X1-3.
2. Go to the **Operating mode** parameter and select **4..20mA output** or **HART slave +4..20mA output**<sup>3)</sup>.
3. Go to the **Analog input source** parameter and select the tank variable which is to be transmitted via the 4...20mA output.
4. Go to the **0 % value** parameter and enter the value of the selected tank variable which will be mapped to 4 mA.
5. Go to the **100 % value** parameter and enter the value of the selected tank variable which will be mapped to 20 mA.

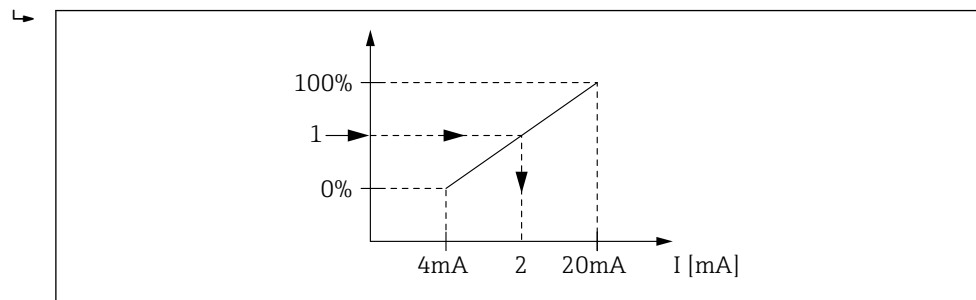

35 Scaling of the tank variable to the output current

- 1 Tank variable
- 2 Output current



**i** After startup of the device, as long as the assigned tank variable is not yet available, the output current assumes the defined error value.

**i** The **Analog I/O** submenu contains more parameters which can be used for a more detailed configuration of the analog output. For a description see → 140

3) "HART slave +4..20mA output" means that the Analog I/O module serves as a HART slave which cyclically sends up to four HART variables to a HART master. For the configuration of the HART output: → 75

### 9.4.13 Configuration of the HART slave + 4-20mA output

If **Operating mode = HART slave +4..20mA output** has been selected for an Analog I/O module, it serves as a HART slave which sends up to four HART variables to a HART master.

 The 4-20 mA signal can be used in this case, too. For its configuration: →  74

#### Standard case: PV = 4-20mA signal

By default, the Primary Variable (PV) is identical to the tank variable transmitted by the 4-20mA output. To define the other HART variables and to configure the HART output in more detail, proceed as follows:

1. Navigate to: Setup → Advanced setup → Communication → HART output → Configuration
2. Go to the **System polling address** parameter and set the HART slave address of the device.
3. Use the following parameters to assign tank variables to the second to fourth HART variable: **Assign SV**, **Assign TV**, **Assign QV**.
  - ↳ The four HART variables are transmitted to a connected HART Master.

#### Special case: PV ≠ 4-20mA signal

In exceptional cases it might be required that the Primary Variable (PV) transmits a different tank variable than the 4-20mA output. This is configured as follows.

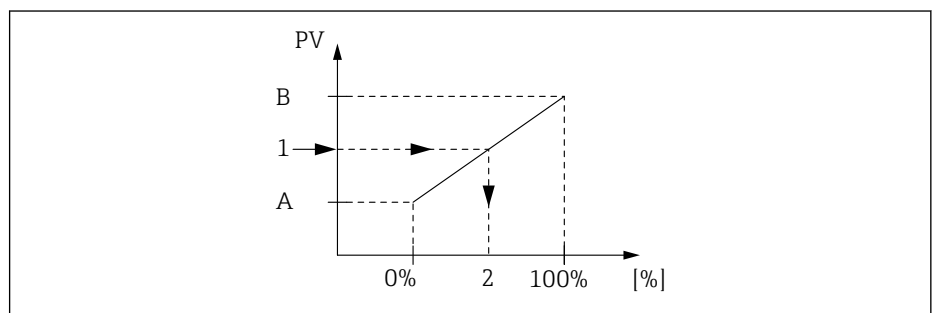

1. Navigate to: Setup → Advanced setup → Communication → HART output → Configuration
2. Go to the **PV source** parameter and select **Custom**.
  - ↳ The following additional parameters appear in the submenu: **Assign PV**, **0 % value**, **100 % value** and **PV mA selector**.
3. Go to the **Assign PV** parameter and select the tank variable to be transmitted as the Primary Variable (PV).
4. Use the **0 % value** and **100 % value** parameters to define a range for the PV. The **Percent of range** parameter indicates the percentage for the actual value of the PV. It is included in the cyclical output to the HART master.
  - ↳



 36 Scaling of the tank variable to the percentage

- A 0 % value
- B 100 % value
- 1 Primary variable (PV)
- 2 Percent of range

5. Use the **PV mA selector** parameter to define whether the output current of an Analog I/O module is to be included in the cyclical HART output.

-  After startup of the device, as long as the assigned tank variable is not yet available, the output current assumes the defined error value.
-  The **PV mA selector** parameter does not influence the output current at the terminals of the Analog I/O module. It only defines whether the value of this current is part of the HART output or not.

### 9.4.14 Configuration of the Modbus output

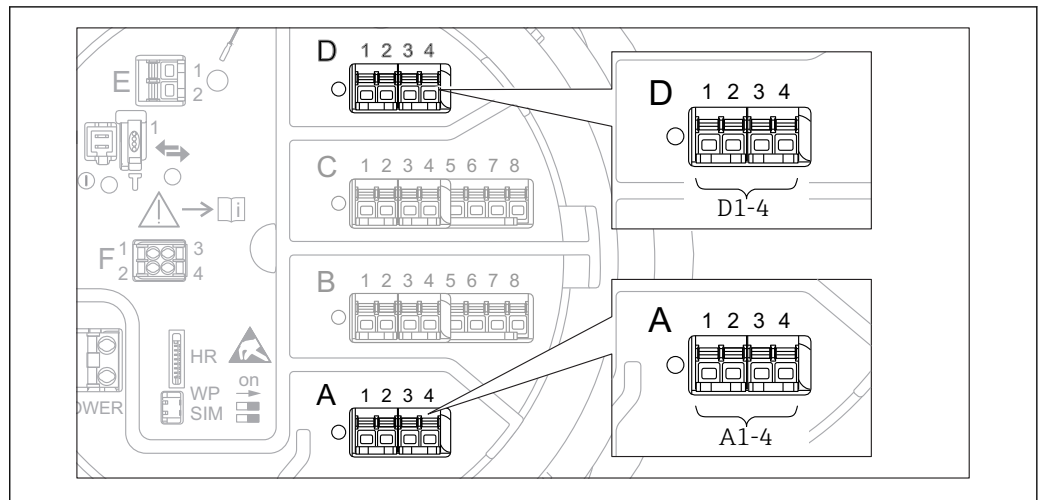

37 Possible locations of the Modbus modules (examples); depending on the device version these modules may also be in slot B or C → 21.

The Micropilot NMR8x acts as a Modbus slave. Measured or calculated tank values are stored in registers which can be requested by a Modbus master.

The following submenu is used to configure the communication between the device and the Modbus master:

Setup → Advanced setup → Communication → Modbus X1-4 → Configuration (→ 156)

### 9.4.15 Configuration of the V1 output

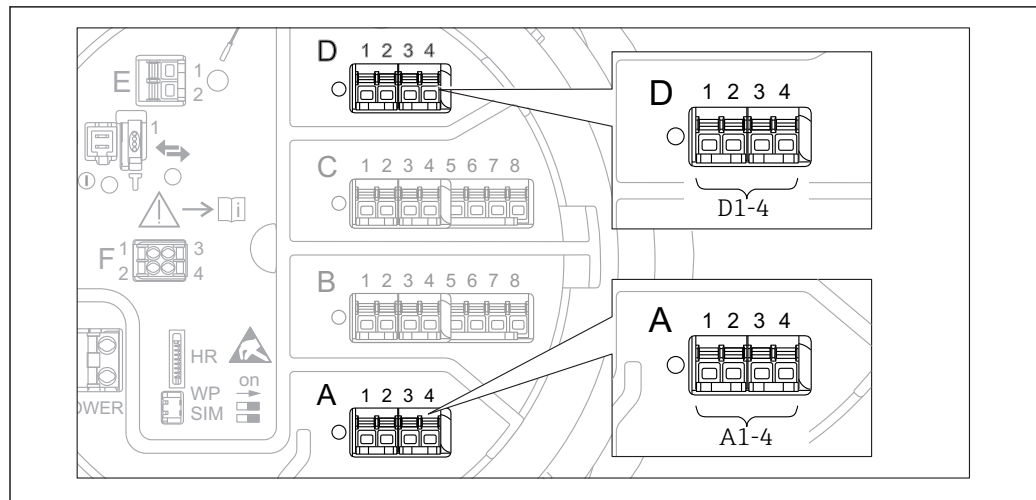

A0031200

38 Possible locations of the V1 modules (examples); depending on the device version these modules may also be in slot B or C → 21.

The following submenus are used to configure the V1 communication between the device and the control system:

- Setup → Advanced setup → Communication → V1 X1-4 → Configuration (→ 159)
- Setup → Advanced setup → Communication → V1 X1-4 → V1 input selector (→ 162)

### 9.4.16 Configuration of the digital outputs

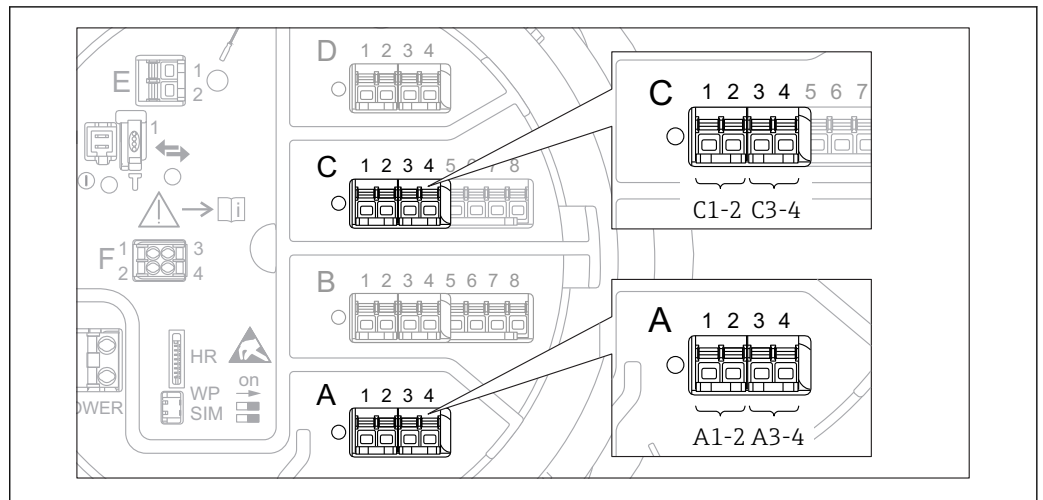

A0026424

39 Possible locations of the Digital I/O modules (examples); the order code defines the number and location of Digital I/O modules → 21.

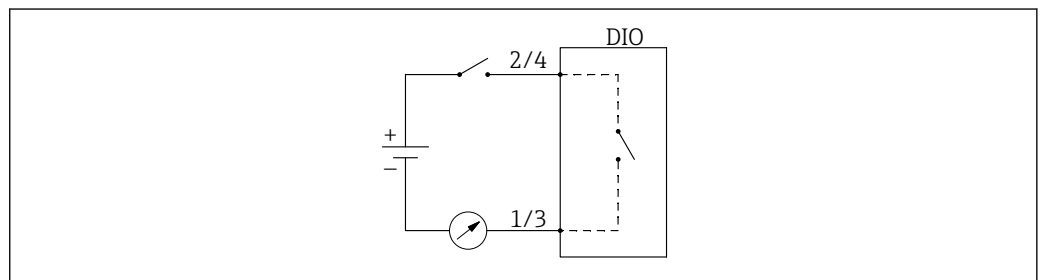

A0033029

40 Usage of the Digital I/O module as a digital output

There is a **Digital Xx-x** submenu for each digital I/O module of the device. "X" designates the slot in the terminal compartment, "x-x" the terminals within this slot. The most important parameters of this submenu are **Operating mode**, **Digital input source** and **Contact type**.

A digital output can be used to

- output the state of an alarm (if an alarm has been configured → 73)
- transmit the status of a digital input (if a digital input has been configured → 66)

To configure a digital output, proceed as follows:

1. Navigate to Setup → Advanced setup → Input/output → Digital Xx-x, where Xx-x designates the digital I/O module to be configured.
2. Go to the **Operating mode** parameter and select the **Output passive** option.
3. Go to the **Digital input source** parameter and select the alarm or digital input to be transmitted.
4. Go to the **Contact type** parameter and select how the internal state of the alarm or digital input is to be mapped to the digital output (see table below).

| <ul style="list-style-type: none"> <li>▪ State of the alarm</li> <li>▪ Internal state of the digital input</li> </ul> | Switching state of the digital output |                                |
|---|---------------------------------------|--------------------------------|
|   | Contact type = Normally open          | Contact type = Normally closed |
| Inactive  | Open                                  | Closed                         |
| Active  | Closed                                | Open                           |

- i
  - For SIL applications, **Contact type** is automatically set to **Normally closed** by the device when starting the SIL confirmation procedure.
  - In case of a power supply failure, the switching state is always "open", irrespective of the selected option.
  - The **Digital Xx-x** submenu contains additional parameters for a more detailed configuration of the Digital Input. For a description refer to →  150.



## 9.5 Advanced settings



For a more detailed configuration of the signal inputs, the tank calculations and the signal outputs refer to the **Advanced setup** submenu (→  126).

## 9.6 Simulation

To check the correct configuration of the device and of the control system, it is possible to simulate different situations (measured values, diagnostic messages etc.). See the **Simulation** submenu (→  243) for details.

## 9.7 Protecting settings from unauthorized access



There are two possibilities to protect the settings from unauthorized access:

- By an access code (→  46)  
This locks the access via the display and operating module.
- By the protection switch (→  47)  
This locks the access to W&M-related parameters by any user interface (display and operating module, FieldCare, other configuration tools).

## 10 Operation

### 10.1 Reading off the device locking status

Depending on the locking state of the device some operations may be locked. The current locking status is indicated at: Setup → Advanced setup → Locking status. The following table summarizes the different locking statuses:

| Locking status              | Meaning  | Unlocking procedure  |
|-----------------------------|--|--|
| Hardware locked             | The device is locked by the write-protection switch in the terminal compartment.   | →  47 |
| SIL locked                  | The device is in SIL-locked mode.  | See the SIL Safety manual  |
| CT active - all parameters  | The custody transfer mode is active.   | →  47 |
| WHG locked (in preparation) | The device is in WHG-locked mode.  | in preparation   |
| Temporarily locked          | Write access to the parameters is temporarily lock due to device-internal processing (e.g. data upload/download, reset). Once the internal processing has been completed, the parameters can be changed again. | Wait for completion of the device-internal processing.                                   |

A locking is indicated by the write protection symbol in the header of the display:

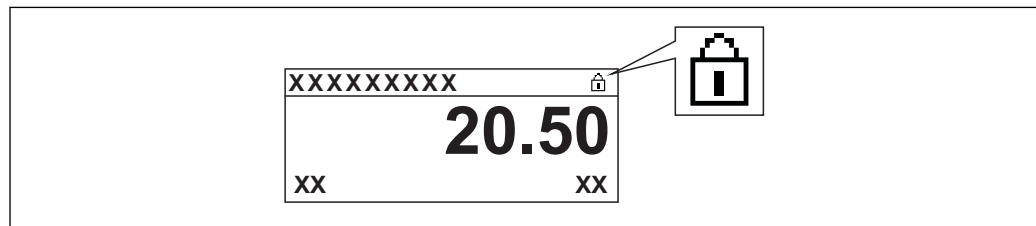

A0015870

### 10.2 Reading off measured values

Tank values can be read off in the following submenus:

- Operation → Level
- Operation → Temperature
- Operation → Density
- Operation → Pressure

# 11 Diagnostics and troubleshooting

## 11.1 General trouble shooting

### 11.1.1 General errors

| Error  | Possible cause  | Remedial action  |
|--|---|--|
| Device does not respond.   | Supply voltage not connected.                             | Connect the correct voltage.   |
|  | The cables do not contact the terminals properly.         | Ensure electrical contact between the cable and the terminal.                                  |
| Values on the display invisible  | The plug of the display cable is not connected correctly. | Connect the plug correctly.  |
|  | Display is defective.                                     | Replace display.   |
|  | Display contrast too low.                                 | Set Setup → Advanced setup → Display → Contrast display to a value $\geq 60$ %.                |
| "Communication error" is indicated on the display when starting the device or connecting the display | Electromagnetic interference                              | Check grounding of the device.   |
|  | Broken display cable or display plug.                     | Exchange display.  |
| CDI communication does not work.   | Wrong setting of the COM port on the computer.            | Check the setting of the COM port on the computer (e.g. FieldCare) and change it if necessary. |
| Device measures incorrectly.   | Parametrization error                                     | Check and adjust parameterization.   |

## 11.2 Diagnostic information on local display

### 11.2.1 Diagnostic message

Faults detected by the self-monitoring system of the measuring device are displayed as a diagnostic message in alternation with the measured value display.

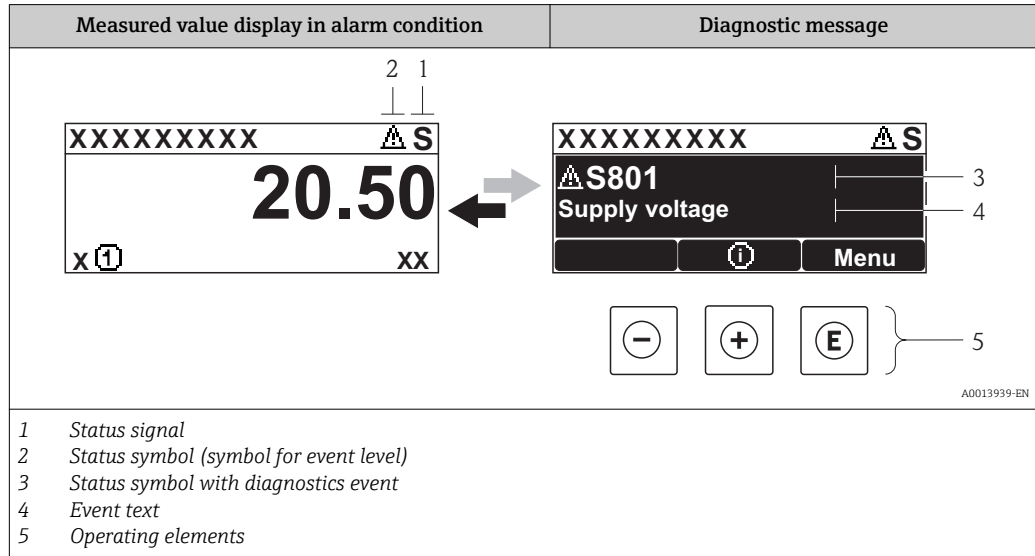

### Status signals

|                                     |   |
|-------------------------------------|---|
| <b>F</b><br><small>A0013956</small> | <b>"Failure"</b><br>A device error is present. The measured value is no longer valid.   |
| <b>C</b><br><small>A0013959</small> | <b>"Function check"</b><br>The device is in service mode (e.g. during a simulation or a warning).   |
| <b>S</b><br><small>A0013958</small> | <b>"Out of specification"</b><br>The device is operated: <ul style="list-style-type: none"> <li>▪ Outside of its technical specifications (e.g. during startup or a cleaning)</li> <li>▪ Outside of the configuration carried out by the user (e.g. level outside configured span)</li> </ul> |
| <b>M</b><br><small>A0013957</small> | <b>"Maintenance required"</b><br>Maintenance is required. The measured value is still valid.  |

### Status symbol (symbol for event level)

|                             |   |
|-----------------------------|---|
| <br><small>A0013961</small> | <b>"Alarm" status</b><br>The measurement is interrupted. The signal outputs take on the defined alarm condition. A diagnostic message is generated. |
| <br><small>A0013962</small> | <b>"Warning" status</b><br>The device continues to measure. A diagnostic message is generated.  |

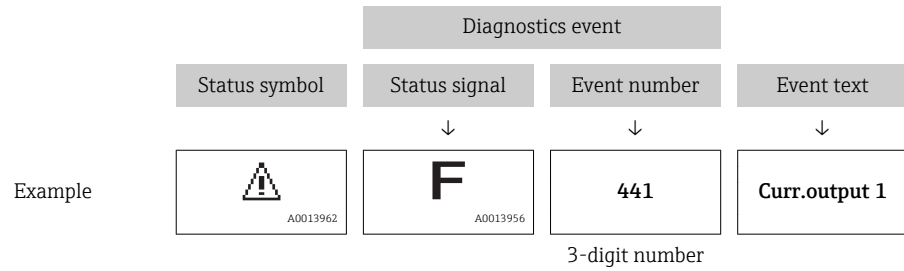

### Diagnostics event and event text

The fault can be identified using the diagnostics event. The event text helps you by providing information about the fault. In addition, the corresponding symbol is displayed before the diagnostics event.



If two or more diagnostic messages are pending simultaneously, only the message with the highest priority is shown. Additional pending diagnostic messages can be shown in **Diagnostic list** submenu (→  239).

### Operating elements

| Operating functions in menu, submenu   |   |
|--|---|
| <br><small>A0013970</small>  | <b>Plus key</b><br>Opens the message about the remedial measures. |
| <br><small>A0013952</small> | <b>Enter key</b><br>Opens the operating menu.                     |

### 11.2.2 Calling up remedial measures

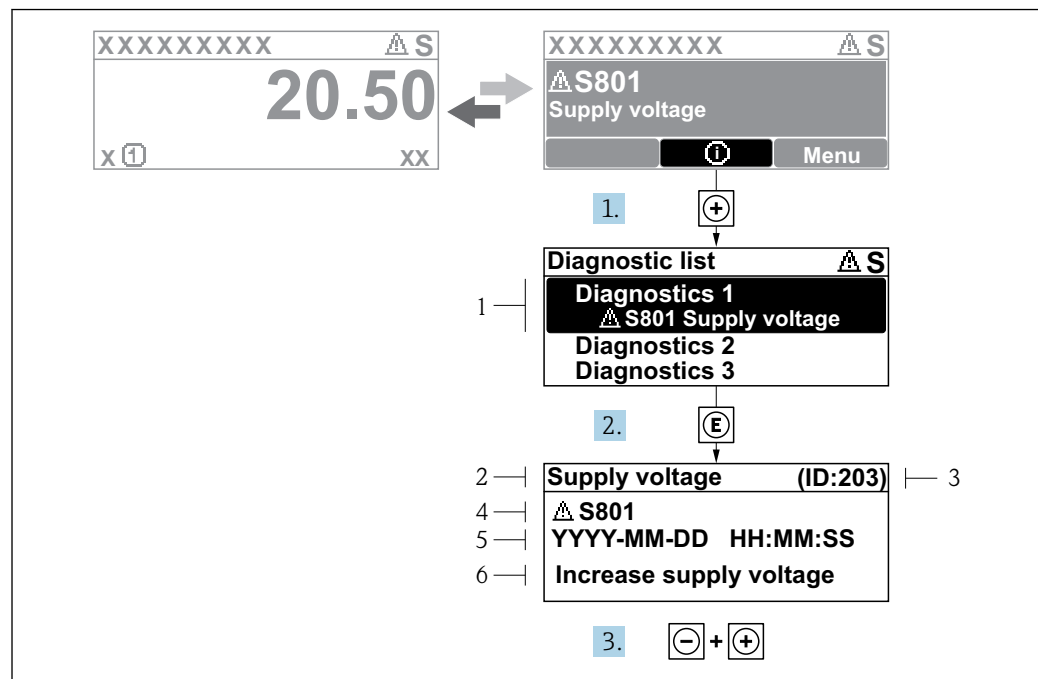

A0032957-EN

41 Message for remedial measures

- 1 Diagnostic information
- 2 Short text
- 3 Service ID
- 4 Diagnostic behavior with diagnostic code
- 5 Operation time of occurrence
- 6 Remedial measures

A diagnostic message appears in the standard view (measured value display).

1. Press  $\oplus$  ( $\text{ⓘ}$  symbol).
  - ↳ The **Diagnostic list** submenu opens.
2. Select the desired diagnostic event with  $\oplus$  or  $\ominus$  and press  $\text{⏎}$ .
  - ↳ The message for the remedial measures for the selected diagnostic event opens.
3. Press  $\ominus + \oplus$  simultaneously.
  - ↳ The message for the remedial measures closes.

The user is in the **Diagnostics** menu at an entry for a diagnostics event, e.g. in the **Diagnostic list** submenu or in the **Previous diagnostics**.

1. Press  $\text{⏎}$ .
  - ↳ The message for the remedial measures for the selected diagnostic event opens.
2. Press  $\ominus + \oplus$  simultaneously.
  - ↳ The message for the remedial measures closes.

### 11.3 Diagnostic information in FieldCare

Any faults detected by the measuring device are displayed on the home page of the operating tool once the connection has been established.

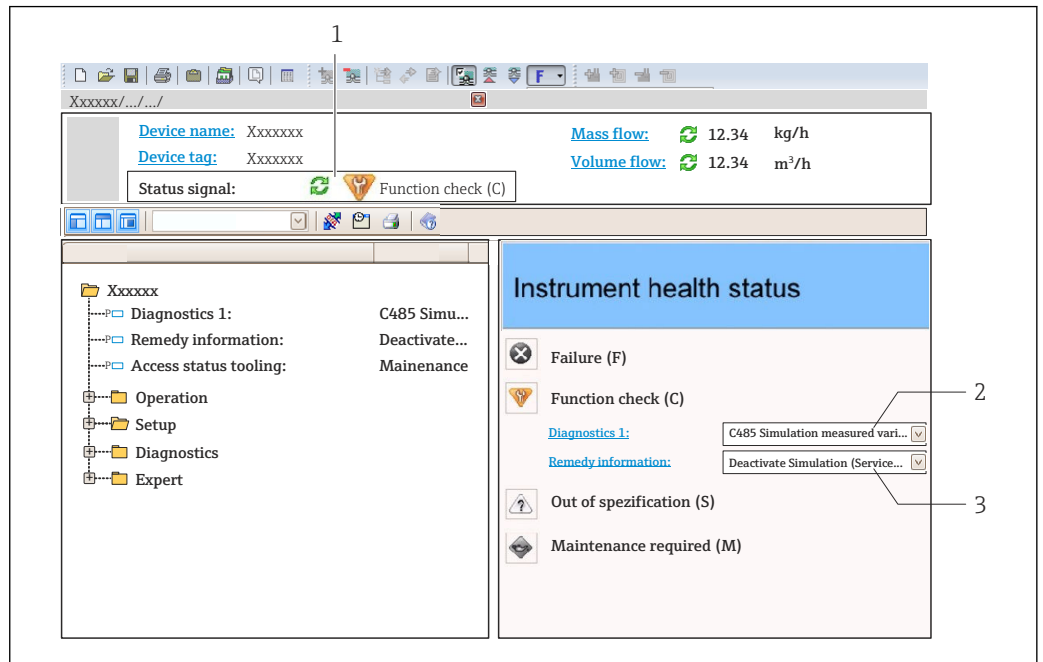

- 1 Status area with status signal
- 2 Diagnostic information
- 3 Remedial measures with Service ID

**i** Furthermore, diagnostic events that have occurred can be viewed in the **Diagnostic list** submenu.

#### 11.3.1 Status signals

The status signals provide information on the state and reliability of the device by categorizing the cause of the diagnostic information (diagnostic event).

| Symbol       | Meaning   |
|--------------|---|
| <br>A0017271 | <b>Failure</b><br>A device error has occurred. The measured value is no longer valid.   |
| <br>A0017278 | <b>Function check</b><br>The device is in service mode (e.g. during a simulation or a warning).   |
| <br>A0017277 | <b>Out of specification</b><br>The device is operated outside its technical specification limits (e.g. outside the process temperature range) |
| <br>A0017276 | <b>Maintenance required</b><br>Maintenance is required. The measured value is still valid.  |

**i** The status signals are categorized in accordance with VDI/VDE 2650 and NAMUR Recommendation NE 107.

### 11.3.2 Calling up remedy information

Remedy information is provided for every diagnostic event to ensure that problems can be rectified quickly:

- On the home page  
Remedy information is displayed in a separate field below the diagnostics information.
- In the **Diagnostics** menu  
Remedy information can be called up in the working area of the user interface.

The user is in the **Diagnostics** menu.

1. Call up the desired parameter.
2. On the right in the working area, mouse over the parameter.
  - ↳ A tool tip with remedy information for the diagnostic event appears.



## 11.4 Overview of the diagnostic messages

| Diagnostic number               | Short text                     | Remedy instructions   | Status signal [from the factory] | Diagnostic behavior [from the factory] |
|---------------------------------|--------------------------------|---|----------------------------------|--|
| <b>Diagnostic of sensor</b>     |                                |   |                                  |  |
| 102                             | Sensor incompatible error      | 1. Restart device<br>2. Contact service   | F                                | Alarm                                  |
| 150                             | Detector error                 | 1. Restart device<br>2. Check electrical connections of detector<br>3. Replace detector unit              | F                                | Alarm                                  |
| 151                             | Sensor electronic failure      | Replace sensor electronic module  | F                                | Alarm                                  |
| <b>Diagnostic of electronic</b> |                                |   |                                  |  |
| 242                             | Software incompatible          | 1. Check software<br>2. Flash or change main electronics module   | F                                | Alarm                                  |
| 252                             | Modules incompatible           | 1. Check if correct electronic modul is plugged<br>2. Replace electronic module                           | F                                | Alarm                                  |
| 261                             | Electronic modules             | 1. Restart device<br>2. Check electronic modules<br>3. Change I/O Modul or main electronics               | F                                | Alarm                                  |
| 262                             | Module connection              | 1. Check module connections<br>2. Change electronic modules   | F                                | Alarm                                  |
| 270                             | Main electronic failure        | Replace main electronics  | F                                | Alarm                                  |
| 271                             | Main electronic failure        | 1. Restart device<br>2. Change main electronic module   | F                                | Alarm                                  |
| 272                             | Main electronic failure        | 1. Restart device<br>2. Contact service   | F                                | Alarm                                  |
| 273                             | Main electronic failure        | 1. Emergency operation via display<br>2. Change main electronics  | F                                | Alarm                                  |
| 275                             | I/O module failure             | 1. Restart device<br>2. Change I/O module   | F                                | Alarm                                  |
| 276                             | I/O module faulty              | 1. Restart device<br>2. Change I/O module   | F                                | Alarm                                  |
| 282                             | Data storage                   | 1. Restart device<br>2. Contact service   | F                                | Alarm                                  |
| 283                             | Memory content                 | 1. Transfer data or reset device<br>2. Contact service  | F                                | Alarm                                  |
| 284                             | Detector SW update in progress | Firmware update active, please wait!  | F                                | Alarm                                  |
| 311                             | Electronic failure             | Maintenance required!<br>1. Do not perform reset<br>2. Contact service                                    | M                                | Warning                                |
| 333                             | System recovery required       | HW change detected<br>System configuration recovery required<br>Go to menu on device and perform recovery | F                                | Alarm                                  |
| 334                             | System recovery failure        | HW changed, system recovery failure. Return to factory  | F                                | Alarm                                  |

| Diagnostic number                  | Short text                            | Remedy instructions  | Status signal [from the factory] | Diagnostic behavior [from the factory] |
|------------------------------------|---------------------------------------|--|----------------------------------|--|
| 381                                | Displacer distance invalid            | 1. Calibrate sensor<br>2. Restart device<br>3. Replace sensor electronics                        | F                                | Alarm                                  |
| 382                                | Sensor communication                  | 1. Check connection of sensor electronics<br>2. Restart device<br>3. Replace sensor electronics  | F                                | Alarm                                  |
| <b>Diagnostic of configuration</b> |                                       |  |                                  |  |
| 400                                | AIO simulation output                 | Deactivate simulation AIO output   | C                                | Warning                                |
| 401                                | DIO simulation output                 | Deactivate simulation DIO output   | C                                | Warning                                |
| 403                                | Calibration AIO                       | 1. Restart device<br>2. Change I/O module  | F                                | Alarm                                  |
| 404                                | Calibration AIP                       | 1. Restart device<br>2. Change I/O module  | F                                | Alarm                                  |
| 405                                | COMM timeout DIO 1 to 8               | 1. Check wiring<br>2. Change I/O module  | F                                | Alarm                                  |
| 406                                | IOM offline                           | 1. Check wiring<br>2. Change I/O module  | F                                | Alarm                                  |
| 407                                | COMM timeout AIO 1 to 2               | 1. Check wiring<br>2. Change I/O module  | F                                | Alarm                                  |
| 408                                | Invalid range AIO 1 to 2              | 1. Check device configuration.<br>2. Check wiring.   | C                                | Warning                                |
| 409                                | RTD temp out of range 1 to 2          | 1. Check electronic modules<br>2. Change I/O or main electronic module                           | C                                | Warning                                |
| 410                                | Data transfer                         | 1. Check connection<br>2. Retry data transfer  | F                                | Alarm                                  |
| 411                                | Hart device 1 to 15 has malfunction   | 1. Check HART device<br>2. Change HART device  | F                                | Alarm <sup>1)</sup>                    |
| 412                                | Processing download                   | Download active, please wait   | C                                | Warning                                |
| 413                                | NMT 1 to 15: element is open or short | 1. Check NMT wiring connection<br>2. Replace NMT   | C                                | Warning                                |
| 415                                | Hart device 1 to 15 offline           | 1. Check HART device<br>2. Change HART device  | C                                | Warning                                |
| 434                                | Real time clock defective             | Replace main electronics   | C                                | Warning                                |
| 436                                | Date/Time incorrect                   | Check date and time settings.  | M                                | Warning                                |
| 437                                | Configuration incompatible            | 1. Restart device<br>2. Contact service  | F                                | Alarm                                  |
| 438                                | Dataset                               | 1. Check data set file<br>2. Check device configuration<br>3. Up- and download new configuration | M                                | Warning                                |
| 441                                | AIO 1 to 2 current output alarm       | 1. Check process<br>2. Check current output settings   | F                                | Alarm                                  |
| 442                                | AIO 1 to 2 current output warning     | 1. Check process<br>2. Check current output settings   | C                                | Warning                                |
| 443                                | AIO 1 to 2 Input not HART compatible  | Change PV source or AIO input source.  | C                                | Warning                                |
| 484                                | Failure mode simulation               | Deactivate simulation  | C                                | Alarm                                  |

| Diagnostic number | Short text                              | Remedy instructions   | Status signal [from the factory] | Diagnostic behavior [from the factory] |
|-------------------|---|-----------------------|----------------------------------|--|
| 495               | Diagnostic event simulation             | Deactivate simulation | C                                | Warning                                |
| 500               | AIO C1-3 source no longer valid         | Change input source   | C                                | Warning                                |
| 501               | Level source no longer valid            | Change input source   | C                                | Warning                                |
| 502               | GP1 source no longer valid              | Change input source   | C                                | Warning                                |
| 503               | GP2 source no longer valid              | Change input source   | C                                | Warning                                |
| 504               | GP3 source no longer valid              | Change input source   | C                                | Warning                                |
| 505               | GP4 source no longer valid              | Change input source   | C                                | Warning                                |
| 506               | Water level source no longer valid      | Change input source   | C                                | Warning                                |
| 507               | Liquid temp source no longer valid      | Change input source   | C                                | Warning                                |
| 508               | Vapor temperatur source no longer valid | Change input source   | C                                | Warning                                |
| 509               | Air temperature source no longer valid  | Change input source   | C                                | Warning                                |
| 510               | P1 source no longer valid               | Change input source   | C                                | Warning                                |
| 511               | P2 source no longer valid               | Change input source   | C                                | Warning                                |
| 512               | P3 source no longer valid               | Change input source   | C                                | Warning                                |
| 513               | Upper density source no longer valid    | Change input source   | C                                | Warning                                |
| 514               | Middle density source no longer valid   | Change input source   | C                                | Warning                                |
| 515               | Lower density source no longer valid    | Change input source   | C                                | Warning                                |
| 516               | Gauge command source no longer valid    | Change input source   | C                                | Warning                                |
| 517               | Gauge status source no longer valid     | Change input source   | C                                | Warning                                |
| 518               | Average density source no longer valid  | Change input source   | C                                | Warning                                |
| 519               | Upper interface source no longer valid  | Change input source   | C                                | Warning                                |
| 520               | Lower interface source no longer valid  | Change input source   | C                                | Warning                                |
| 521               | Bottom level source no longer valid     | Change input source   | C                                | Warning                                |
| 522               | Displacer position source not valid     | Change input source   | C                                | Warning                                |
| 523               | Distance source no longer valid         | Change input source   | C                                | Warning                                |
| 524               | Balance flag source no longer valid     | Change input source   | C                                | Warning                                |
| 525               | One time cmd source no longer valid     | Change input source   | C                                | Warning                                |
| 526               | Alarm 1 to 4 source no longer valid     | Change input source   | C                                | Warning                                |

| Diagnostic number | Short text                               | Remedy instructions  | Status signal [from the factory] | Diagnostic behavior [from the factory] |
|-------------------|--|--|----------------------------------|--|
| 527               | AIO B1-3 source no longer valid          | Change input source  | C                                | Warning                                |
| 528               | CTSh                                     | 1. Check device configuration.<br>2. Check wiring.   | C                                | Warning                                |
| 529               | HTG                                      | 1. Check device configuration.<br>2. Check wiring.   | C                                | Warning                                |
| 530               | HTMS                                     | 1. Check device configuration.<br>2. Check wiring.   | C                                | Warning                                |
| 531               | HyTD correction value                    | 1. Check device configuration.<br>2. Check wiring.   | C                                | Warning                                |
| 532               | HART output: PV source not valid         | Change input source  | C                                | Warning                                |
| 533               | HART output: SV source not valid         | Change input source  | C                                | Warning                                |
| 534               | HART output: QV source not valid         | Change input source  | C                                | Warning                                |
| 535               | HART output: TV source not valid         | Change input source  | C                                | Warning                                |
| 536               | Display: source no longer valid          | Change input source  | C                                | Warning                                |
| 537               | Trend: source no longer valid            | Change input source  | C                                | Warning                                |
| 538               | HART output: PV mA source not valid      | Change input source  | C                                | Warning                                |
| 539               | Modbus 1-4 SP source invalid             | Set valid SP input selector  | C                                | Warning                                |
| 540               | V1 1-4 SP source invalid                 | Set valid SP input selector  | C                                | Warning                                |
| 541               | Modbus 1-4 alarm source invalid          | Set valid alarm input selector   | C                                | Warning                                |
| 542               | V1 1-4 alarm source invalid              | Set valid alarm input selector   | C                                | Warning                                |
| 543               | Modbus 1-4 analog source invalid         | Set valid analog input selector  | C                                | Warning                                |
| 544               | V1 1-4 analog source invalid             | Set valid analog input selector  | C                                | Warning                                |
| 545               | Modbus 1-4 user value source invalid     | Set valid user value input selector  | C                                | Warning                                |
| 546               | Modbus 1-4 discrete value source invalid | Set valid user discrete input selector   | C                                | Warning                                |
| 547               | V1 1-4 user value source invalid         | Set valid user value input selector  | C                                | Warning                                |
| 548               | V1 1-4 discrete value source invalid     | Set valid user discrete input selector   | C                                | Warning                                |
| 549               | Modbus 1-4 percent source invalid        | Set valid percentage input selector  | C                                | Warning                                |
| 550               | V1 1-4 percent source invalid            | Set valid percentage input selector  | C                                | Warning                                |
| 560               | Calibration mandatory                    | 1. Carry out weight calibration<br>2. Carry out reference calibration<br>3. Carry out drum calibration | C                                | Alarm                                  |
| 564               | DIO B1-2 source no longer valid          | Change input source  | C                                | Warning                                |
| 565               | DIO B3-4 source not valid                | Change input source  | C                                | Warning                                |

| Diagnostic number            | Short text                         | Remedy instructions   | Status signal [from the factory] | Diagnostic behavior [from the factory] |
|------------------------------|------------------------------------|---|----------------------------------|--|
| 566                          | DIO C1-2 source no longer valid    | Change input source   | C                                | Warning                                |
| 567                          | DIO C3-4 source no longer valid    | Change input source   | C                                | Warning                                |
| 568                          | DIO D1-2 source no longer valid    | Change input source   | C                                | Warning                                |
| 569                          | DIO D3-4 source no longer valid    | Change input source   | C                                | Warning                                |
| 585                          | Simulation distance                | Deactivate simulation   | C                                | Warning                                |
| 586                          | Record map                         | Recording of mapping please wait                                    | C                                | Warning                                |
| 598                          | DIO A1-2 source no longer valid    | Change input source   | C                                | Warning                                |
| 599                          | DIO A3-4 source no longer valid    | Change input source   | C                                | Warning                                |
| <b>Diagnostic of process</b> |                                    |   |                                  |  |
| 801                          | Energy too low                     | Increase supply voltage   | S                                | Warning                                |
| 803                          | Current loop                       | 1. Check device configuration.<br>2. Check wiring.                  | F                                | Alarm                                  |
| 803                          | Current loop 1 to 2                |   | M                                | Warning                                |
| 803                          | Current loop                       |   | C                                | Warning                                |
| 825                          | System temperature                 | 1. Check ambient temperature<br>2. Check process temperature        | S                                | Warning                                |
| 825                          | System temperature                 |   | F                                | Alarm                                  |
| 826                          | Sensor temperature                 | 1. Check ambient temperature<br>2. Check process temperature        | S                                | Warning                                |
| 826                          | Sensor temperature                 |   | F                                | Alarm                                  |
| 844                          | Process value out of specification | 1. Check process value<br>2. Check application<br>3. Check sensor   | S                                | Alarm <sup>1)</sup>                    |
| 844                          | Process value out of specification |   | S                                | Warning                                |
| 903                          | Current loop 1 to 2                | 1. Check device configuration.<br>2. Check wiring.                  | F                                | Alarm                                  |
| 904                          | Digital output 1 to 8              | 1. Check device configuration.<br>2. Check wiring.                  | F                                | Alarm                                  |
| 941                          | Echo lost                          | 1. Check process value<br>2. Check application<br>3. Check sensor   | S                                | Warning                                |
| 942                          | In safety distance                 | 1. Check level<br>2. Check safety distance<br>3. Reset self holding | S                                | Warning                                |
| 943                          | In blocking distance               | Reduced accuracy<br>Check level                                     | S                                | Warning                                |
| 950                          | Advanced diagnostics               | Maintain your diagnostic event                                      | M                                | Warning                                |
| 961                          | Alarm 1 to 4 HighHigh              | 1. Check alarm source<br>2. Check configuration settings            | C                                | Warning                                |
| 962                          | Alarm 1 to 4 High                  | 1. Check alarm source<br>2. Check configuration settings            | C                                | Warning                                |
| 963                          | Alarm 1 to 4 Low                   | 1. Check alarm source<br>2. Check configuration settings            | C                                | Warning                                |

| Diagnostic number | Short text            | Remedy instructions   | Status signal [from the factory] | Diagnostic behavior [from the factory] |
|-------------------|-----------------------|---|----------------------------------|--|
| 964               | Alarm 1 to 4 LowLow   | 1. Check alarm source<br>2. Check configuration settings            | C                                | Warning                                |
| 965               | Alarm 1 to 4 HighHigh | 1. Check alarm source<br>2. Check configuration settings            | F                                | Alarm                                  |
| 966               | Alarm 1 to 4 High     | 1. Check alarm source<br>2. Check configuration settings            | F                                | Alarm                                  |
| 967               | Alarm 1 to 4 Low      | 1. Check alarm source<br>2. Check configuration settings            | F                                | Alarm                                  |
| 968               | Alarm 1 to 4 LowLow   | 1. Check alarm source<br>2. Check configuration settings            | F                                | Alarm                                  |
| 970               | Overtension           | 1. Check displacer and process conditions<br>2. Release overtension | C                                | Alarm                                  |
| 971               | Undertension          | Check displacer and process.  | C                                | Alarm                                  |

- 1) Diagnostic behavior can be changed.



## 11.5 Diagnostic list

In the Diagnostic list submenu, up to 5 currently pending diagnostic messages can be displayed. If more than 5 messages are pending, the messages with the highest priority are shown on the display.

### Navigation path

Diagnostics → Diagnostic list

### Calling up and closing the remedial measures

1. Press .
  - ↳ The message for the remedial measures for the selected diagnostic event opens.
2. Press  +  simultaneously.
  - ↳ The message about the remedial measures closes.

## 11.6 Reset measuring device

To reset the device to a defined state use the **Device reset** parameter (→  235).

## 11.7 Device information

Information on the device (order code, hardware and software version of the individual modules etc.) can be found in the **Device information** submenu (→  240).

## 11.8 Firmware history

| Date    | Software version | Modifications             | Documentation (NMR84)  |                           |                       |
|---------|------------------|---------------------------|------------------------|---------------------------|-----------------------|
|         |                  |                           | Operating Instructions | Description of Parameters | Technical Information |
| 04.2016 | 01.00.zz         | Original software         | BA01453G/00/EN/01.16   | GP01071G/00/EN/01.16      | TI01253G/00/EN/01.16  |
| 12.2016 | 01.02.zz         | Bugfixes and improvements | BA01453G/00/EN/02.17   | GP01071G/00/EN/01.17      | TI01253G/00/EN/02.17  |



## 12 Maintenance

### 12.1 Maintenance tasks

No special maintenance work is required.

#### 12.1.1 Exterior cleaning

When cleaning the exterior of measuring devices, always use cleaning agents that do not attack the surface of the housing or the seals.

### 12.2 Endress+Hauser services

Endress+Hauser offers a wide variety of services for maintenance such as recalibration, maintenance service or device tests.



Your Endress+Hauser Sales Center can provide detailed information on the services.

## 13 Repair

### 13.1 General information on repairs

#### 13.1.1 Repair concept

The Endress+Hauser repair concept assumes that the devices have a modular design and that repairs can be done by the Endress+Hauser service or specially trained customers.

Spare parts are contained in suitable kits. They contain the related replacement instructions.

For more information on service and spare parts, contact the Service Department at Endress+Hauser.

#### 13.1.2 Repairs to Ex-approved devices

When carrying out repairs to Ex-approved devices, please note the following:

- Repairs to Ex-approved devices may only be carried out by trained personnel or by the Endress+Hauser Service.
- Comply with the prevailing standards, national Ex-area regulations, safety instructions (XA) and certificates.
- Only use original spare parts from Endress+Hauser.
- When ordering a spare part, please note the device designation on the nameplate. Only replace parts with identical parts.
- Carry out repairs according to the instructions. On completion of repairs, carry out the specified routine test on the device.
- Only Endress+Hauser Service may convert a certified device into a different certified variant.
- Document all repair work and conversions.

#### 13.1.3 Replacement of a device or electronic module

After a complete device or the electronic mainboard has been replaced, the parameters can be downloaded into the instrument again via FieldCare.

Condition: The configuration of the old device has been saved to the computer via FieldCare.

You can continue to measure without carrying out a new setup. Only a linearization and a tank map (interference echo suppression) have to be recorded again.

##### The "Save/Restore" function

After a device configuration has been saved to a computer and restored to the device using the **Save/Restore** function of FieldCare, the device must be restarted by the following setting:

**Setup** → **Advanced setup** → **Administration** → **Device reset** = **Restart device**.

This ensures correct operation of the device after the restore.

### 13.2 Spare parts

Some interchangeable measuring device components are listed on an overview sign in the connection compartment cover.

The spare part overview sign contains the following information:

- A list of the most important spare parts for the measuring device, including their ordering information.
- The URL for the *W@M Device Viewer* ([www.endress.com/deviceviewer](http://www.endress.com/deviceviewer)):  
All the spare parts for the measuring device, along with the order code, are listed here and can be ordered. If available, users can also download the associated Installation Instructions.

### 13.3 Endress+Hauser services

Endress+Hauser offers a wide range of services.

 Your Endress+Hauser Sales Center can provide detailed information on the services.

### 13.4 Return

The measuring device must be returned if it is need of repair or a factory calibration, or if the wrong measuring device has been delivered or ordered. Legal specifications require Endress+Hauser, as an ISO-certified company, to follow certain procedures when handling products that are in contact with the medium.

To ensure safe, swift and professional device returns, please refer to the procedure and conditions for returning devices provided on the Endress+Hauser website at <http://www.endress.com/support/return-material>

### 13.5 Disposal

Observe the following notes during disposal:

- Observe valid federal/national regulations.
- Ensure proper separation and reuse of the device components.

## 14 Accessories

### 14.1 Device-specific accessories

#### 14.1.1 Weather protection cover

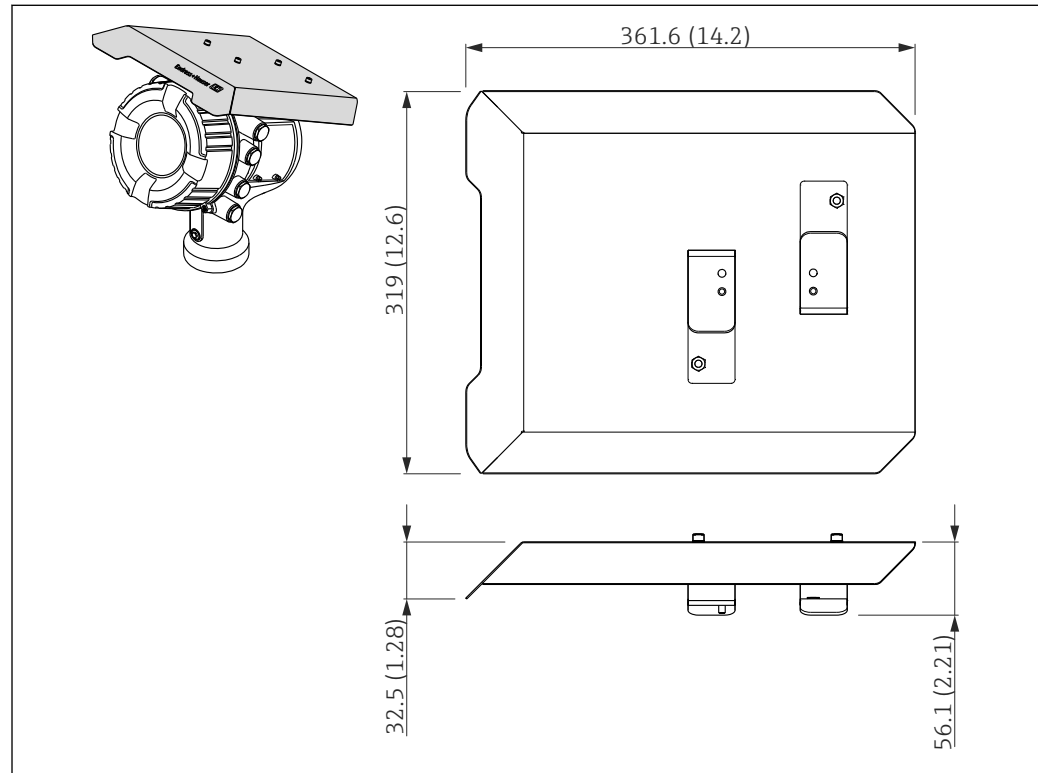

A0028019

42 Weather protection cover; dimensions: mm (in)

#### Materials

| Part                                   | Material      |
|--|---------------|
| Protection cover and mounting brackets | 316L (1.4404) |
| Screws and washers                     | A4            |

- i** The weather protection cover can be ordered together with the device:  
Ordering feature 620 "Accessory Enclosed", option PA "Weather Protection Cover")
- It can also be ordered as an accessory:  
Order code: 71292751 (for NMR8x and NRF8x)

## 14.2 Communication-specific accessories

| Accessory                     | Description  |
|-------------------------------|--|
| WirelessHART Adapter<br>SWA70 | <p>Connects field devices to a WirelessHART network.<br/>The WirelessHART adapter can be mounted directly at a HART device and is easily integrated into an existing HART network. It ensures safe data transmission and can be operated in parallel with other wireless networks.</p> <p> For details refer to Operating Instructions BA00061S</p> |



## 14.3 Service-specific accessories

| Accessory               | Description   |
|-------------------------|---|
| Commubox FXA195<br>HART | <p>For intrinsically safe HART communication with FieldCare via the USB interface.</p> <p> For details refer to Technical Information TI00404F</p> |





| Accessory       | Description   |
|-----------------|---|
| Commubox FXA291 | <p>Connects Endress+Hauser field devices with CDI interface (= Endress+Hauser Common Data Interface) to the USB interface of a computer.</p> <p> For details refer to Technical Information TI00405C</p> |

| Accessory | Description  |
|-----------|--|
| FieldCare | <p>Endress+Hauser's FDT-based Plant Asset Management tool.<br/>Helps to configure and maintain all field devices of your plant. By supplying status information it also supports the diagnosis of the devices.</p> <p> For details refer to Operating Instructions BA00027S and BA00059S.</p> |





## 14.4 System components

| Accessory  | Description   |
|--|---|
| RIA15  | <p>Compact process display unit with very low voltage drop for universal use to display 4 to 20 mA/HART signals</p> <p> For details refer to Technical Information TI01043K.</p> |
| Tankvision <ul style="list-style-type: none"> <li>▪ Tank Scanner NXA820</li> <li>▪ Data Concentrator NXA821</li> <li>▪ Host Link NXA822</li> </ul> | <p>Inventory Management System with completely integrated software for operation via standard web browser</p> <p> For details refer to Technical Information TI00419G.</p>       |















## 15 Operating menu



























-   : Navigation path for operating module at the device
-  : Navigation path for operating tool (e.g. FieldCare)
-  : Parameter can be locked via software locking

























### 15.1 Overview of the operating menu

-  This section lists the parameters of the following menus:
  - Operation (→  111)
  - Setup (→  120)
  - Diagnostics (→  236)
- For the **Expert** menu refer to the "Description of Device Parameters" (GP) of the respective device.
- Depending on the device version and parametrization some parameters will not be available in a given situation. For details refer to the "Prerequisite" category in the description of the respective parameter.
- The representation essentially corresponds to the menu in an operating tool (e.g. FieldCare). On the local display there may be minor differences in the menu structure. Details are mentioned in the description of the respective submenu.

Navigation   Operating tool

|                       |   |
|-----------------------|---|
| Operation             | →  111  |
| ▶ Level               | →  111 |
| Tank level            | →  111 |
| Tank Level %          | →  111 |
| Tank ullage           | →  111 |
| Tank ullage %         | →  112 |
| Upper interface level | →  112 |
| Lower interface level | →  112 |
| Water level           | →  112 |
| Measured level        | →  113 |
| Distance              | →  113 |
| ▶ Temperature         | →  113 |
| Air temperature       | →  113 |
| Liquid temperature    | →  113 |

|   |   |
|---|---|
| Vapor temperature   | →  114   |
| ▶ NMT element values  | →  114   |
| ▶ Element temperature   | →  114   |
| Element temperature 1 to 24   | →  114   |
| ▶ Element position  | →  115   |
| Element position 1 to 24  | →  115   |
| ▶ Density   | →  115   |
| Observed density  | →  115   |
| Vapor density   | →  115   |
| Air density   | →  116   |
| Measured upper density  | →  116   |
| Measured middle density   | →  116 |
| Measured lower density  | →  116 |
| ▶ Pressure  | →  117 |
| P1 (bottom)   | →  117 |
| P3 (top)  | →  117 |
| ▶ GP values   | →  118 |
| GP 1 to 4 name  | →  118 |
| GP Value 1  | →  118 |
| GP Value 2  | →  118 |
| GP Value 3  | →  118 |
| GP Value 4  | →  119 |
|  Setup | →  120 |
| Device tag  | →  120 |
| Units preset  | →  120 |

























|                         |   |
|-------------------------|---|
| Tube diameter           | →  121   |
| Empty                   | →  121   |
| Tank reference height   | →  121   |
| Tank level              | →  111   |
| Set level               | →  122   |
| Confirm distance        | →  122   |
| Present mapping         | →  124   |
| Mapping end point       | →  124   |
| Record map              | →  124   |
| Distance                | →  125   |
| Liquid temp source      | →  125 |
| <b>▶ Advanced setup</b> | →  126 |
| Locking status          | →  126 |
| Access status tooling   | →  126 |
| Enter access code       | →  126 |
| <b>▶ Input/output</b>   | →  127 |
| <b>▶ HART devices</b>   | →  127 |
| Number of devices       | →  127 |
| <b>▶ HART Device(s)</b> | →  128 |
| <b>▶ Forget device</b>  | →  133 |
| <b>▶ Analog IP</b>      | →  134 |
| Operating mode          | →  134 |
| RTD type                | →  134 |
| RTD connection type     | →  135 |
| Process value           | →  135 |























|                           |       |
|---------------------------|-------|
| Process variable          | → 136 |
| 0 % value                 | → 136 |
| 100 % value               | → 136 |
| Input value               | → 137 |
| Minimum probe temperature | → 137 |
| Maximum probe temperature | → 137 |
| Probe position            | → 138 |
| Damping factor            | → 138 |
| Gauge current             | → 139 |
| <b>► Analog I/O</b>       | → 140 |
| Operating mode            | → 140 |
| Current span              | → 141 |
| Fixed current             | → 142 |
| Analog input source       | → 142 |
| Failure mode              | → 143 |
| Error value               | → 144 |
| Input value               | → 144 |
| 0 % value                 | → 144 |
| 100 % value               | → 145 |
| Input value %             | → 145 |
| Output values             | → 145 |
| Process variable          | → 146 |
| Analog input 0% value     | → 146 |
| Analog input 100% value   | → 146 |
| Error event type          | → 147 |

|   |       |
|---|-------|
| Process value                           | → 147 |
| Input value in mA                       | → 147 |
| Input value percent                     | → 148 |
| Damping factor                          | → 148 |
| Used for SIL/WHG                        | → 148 |
| Expected SIL/WHG chain                  | → 149 |
| <b>▶ Digital Xx-x</b>                   | → 150 |
| Operating mode                          | → 150 |
| Digital input source                    | → 151 |
| Input value                             | → 152 |
| Contact type                            | → 152 |
| Output simulation                       | → 152 |
| Output values                           | → 153 |
| Readback value                          | → 153 |
| Used for SIL/WHG                        | → 154 |
| <b>▶ Communication</b>                  | → 155 |
| <b>▶ Communication interface 1 to 2</b> |       |
| Communication interface protocol        | → 155 |
| <b>▶ Configuration</b>                  | → 156 |
| <b>▶ Configuration</b>                  | → 159 |
| <b>▶ V1 input selector</b>              | → 162 |
| <b>▶ HART output</b>                    | → 164 |
| <b>▶ Configuration</b>                  | → 164 |
| <b>▶ Information</b>                    | → 172 |

|                         |       |
|-------------------------|-------|
| ▶ Application           | → 174 |
| ▶ Tank configuration    | → 174 |
| ▶ Level                 | → 174 |
| ▶ Temperature           | → 177 |
| ▶ Density               | → 181 |
| ▶ Pressure              | → 183 |
| ▶ Tank calculation      | → 188 |
| ▶ HyTD                  | → 190 |
| ▶ CTSh                  | → 195 |
| ▶ HTMS                  | → 200 |
| ▶ Dip-table             | → 207 |
| ▶ Alarm                 |       |
| ▶ Alarm 1 to 4          | → 209 |
| ▶ Safety settings       | → 217 |
| Output echo lost        | → 217 |
| Delay time echo lost    | → 217 |
| Safety distance         | → 217 |
| ▶ Sensor config         | → 219 |
| Tube diameter           | → 219 |
| ▶ Information           | → 219 |
| Signal quality          | → 219 |
| Absolute echo amplitude | → 219 |

|                         |   |
|-------------------------|---|
| Relative echo amplitude | →  220   |
| Distance                | →  125   |
| <b>► Echo tracking</b>  | →  221   |
| Evaluation mode         | →  221   |
| History reset           | →  221   |
| <b>► Display</b>        | →  222   |
| Language                | →  222   |
| Format display          | →  222   |
| Value 1 to 4 display    | →  223   |
| Decimal places 1 to 4   | →  224   |
| Separator               | →  224   |
| Number format           | →  225 |
| Header                  | →  225 |
| Header text             | →  225 |
| Display interval        | →  226 |
| Display damping         | →  226 |
| Backlight               | →  226 |
| Contrast display        | →  227 |
| <b>► System units</b>   | →  228 |
| Units preset            | →  120 |
| Distance unit           | →  228 |
| Pressure unit           | →  229 |
| Temperature unit        | →  229 |
| Density unit            | →  229 |

|                             |         |
|-----------------------------|---------|
| ▶ <b>Date / time</b>        | → 📄 231 |
| Date/time                   | → 📄 231 |
| Set date                    | → 📄 231 |
| Year                        | → 📄 231 |
| Month                       | → 📄 232 |
| Day                         | → 📄 232 |
| Hour                        | → 📄 232 |
| Minute                      | → 📄 233 |
| ▶ <b>SIL confirmation</b>   | → 📄 234 |
| ▶ <b>Deactivate SIL/WHG</b> | → 📄 234 |
| ▶ <b>Administration</b>     | → 📄 235 |
| Define access code          | → 📄 235 |
| Device reset                | → 📄 235 |
| 🔍 <b>Diagnostics</b>        | → 📄 236 |
| Actual diagnostics          | → 📄 236 |
| Timestamp                   | → 📄 236 |
| Previous diagnostics        | → 📄 236 |
| Timestamp                   | → 📄 237 |
| Operating time from restart | → 📄 237 |
| Operating time              | → 📄 237 |
| Date/time                   | → 📄 231 |
| ▶ <b>Diagnostic list</b>    | → 📄 239 |
| Diagnostics 1 to 5          | → 📄 239 |
| Timestamp 1 to 5            | → 📄 239 |

|  |   |
|--|---|
| <b>► Device information</b>              | →  240   |
| Device tag                               | →  240   |
| Serial number                            | →  240   |
| Firmware version                         | →  240   |
| Firmware CRC                             | →  240   |
| Weight and measures configuration<br>CRC | →  241   |
| Device name                              | →  241   |
| Order code                               | →  241   |
| Extended order code 1 to 3               | →  241   |
| <b>► Simulation</b>                      | →  243   |
| Device alarm simulation                  | →  243  |
| Diagnostic event simulation              | →  243 |
| Simulation distance on                   | →  243 |
| Simulation distance                      | →  244 |
| Current output 1 simulation              | →  244 |
| Simulation value                         | →  244 |
| <b>► Device check</b>                    | →  246 |
| Start device check                       | →  246 |
| Result device check                      | →  246 |
| Level signal                             | →  246 |
| Near distance                            | →  247 |

## 15.2 "Operation" menu

The **Operation** menu (→  111) shows the most important measured values.

*Navigation*        Operation

### 15.2.1 "Level" submenu

*Navigation*        Operation → Level

---

#### Tank level

---

**Navigation**        Operation → Level → Tank level

**Description**      Shows the distance from the zero position (tank bottom or datum plate) to the product surface.

**Additional information**

|              |          |
|--------------|----------|
| Read access  | Operator |
| Write access | -        |

---

#### Tank Level %

---

**Navigation**        Operation → Level → Tank Level %

**Description**      Shows the level as a percentage of the full measuring range.

**Additional information**

|              |          |
|--------------|----------|
| Read access  | Operator |
| Write access | -        |

---

#### Tank ullage

---

**Navigation**        Operation → Level → Tank ullage

**Description**      Shows the remaining empty space in the tank.

**Additional information**

|              |          |
|--------------|----------|
| Read access  | Operator |
| Write access | -        |

---

**Tank ullage %**

---

**Navigation**  Operation → Level → Tank ullage %

**Description** Shows the remaining empty space in percentage related to parameter tank reference height.

**Additional information**

|              |          |
|--------------|----------|
| Read access  | Operator |
| Write access | -        |

---

**Upper interface level**

---

**Navigation**  Operation → Level → Upper interface level

**Description** Shows measured interface level from zero position (tank bottom or datum plate). Value is updated when device generates a valid Interface measurement.

**Additional information**

|              |             |
|--------------|-------------|
| Read access  | Maintenance |
| Write access | -           |

---

**Lower interface level**

---

**Navigation**  Operation → Level → Lower interface level

**Description** Shows measured interface level from zero position (tank bottom or datum plate). Value is updated when device generates a valid interface measurement.

**Additional information**

|              |             |
|--------------|-------------|
| Read access  | Maintenance |
| Write access | -           |

---

**Water level**

---

**Navigation**  Operation → Level → Water level

**Description** Shows the bottom water level.

**Additional information**

|              |          |
|--------------|----------|
| Read access  | Operator |
| Write access | -        |



---

**Measured level**

---

**Navigation**  Operation → Level → Measured level

**Description** Shows the measured level without any correction from the tank calculations.

**Additional information**

|              |          |
|--------------|----------|
| Read access  | Operator |
| Write access | -        |

---

**Distance**

---

**Navigation**  Operation → Level → Distance

**Description** Distance from lower edge of device flange to product surface.

**Additional information**

|              |          |
|--------------|----------|
| Read access  | Operator |
| Write access | -        |

### 15.2.2 "Temperature" submenu

*Navigation*  Operation → Temperature

---

**Air temperature**

---

**Navigation**  Operation → Temperature → Air temperature

**Description** Shows the air temperature.

**Additional information**

|              |          |
|--------------|----------|
| Read access  | Operator |
| Write access | -        |

---

**Liquid temperature**

---

**Navigation**  Operation → Temperature → Liquid temperature

**Description** Shows the average or spot temperature of the measured liquid.

**Additional information**

|              |          |
|--------------|----------|
| Read access  | Operator |
| Write access | -        |

---

**Vapor temperature**

---

**Navigation**   Operation → Temperature → Vapor temperature

**Description** Shows the measured vapor temperature.

**Additional information**

|              |          |
|--------------|----------|
| Read access  | Operator |
| Write access | -        |

**"NMT element values" submenu**

 This submenu is only visible if a Prothermo NMT is connected.

*Navigation*  Operation → Temperature → NMT element values

*"Element temperature" submenu*

*Navigation*  Operation → Temperature → NMT element values → Element temperature

---

**Element temperature 1 to 24**

---

**Navigation**  Operation → Temperature → NMT element values → Element temperature → Element temperature 1 to 24

**Description** Shows the temperature of an element in the NMT.

**Additional information**

|              |          |
|--------------|----------|
| Read access  | Operator |
| Write access | -        |

*"Element position" submenu*

*Navigation*            Operation → Temperature → NMT element values → Element position

**Element position 1 to 24**

**Navigation**            Operation → Temperature → NMT element values → Element position → Element position 1 to 24

**Description**      Shows the position of the selected element in the NMT.



**Additional information**

|              |          |
|--------------|----------|
| Read access  | Operator |
| Write access | -        |

**15.2.3 "Density" submenu**

*Navigation*             Operation → Density



**Observed density**

**Navigation**             Operation → Density → Observed density

**Description**      Calculated density of the product.



**Additional information**

|              |          |
|--------------|----------|
| Read access  | Operator |
| Write access | -        |

 This value is calculated from different measured variables depending on the selected calculation method →  188.

**Vapor density**



**Navigation**             Operation → Density → Vapor density

**Description**      Defines the density of the gas phase in the tank.

**User entry**      0.0 to 500.0 kg/m<sup>3</sup>

**Factory setting**      1.2 kg/m<sup>3</sup>

**Additional information**

|              |             |
|--------------|-------------|
| Read access  | Operator    |
| Write access | Maintenance |

**Air density****Navigation**

Operation → Density → Air density

**Description**

Defines the density of the air surrounding the tank.

**User entry**

0.0 to 500.0 kg/m<sup>3</sup>

**Factory setting**

1.2 kg/m<sup>3</sup>

**Additional information**

|              |             |
|--------------|-------------|
| Read access  | Operator    |
| Write access | Maintenance |

**Measured upper density****Navigation**

Operation → Density → Measured upper density

**Description**

Shows the density of the upper phase.

**Additional information**

|              |          |
|--------------|----------|
| Read access  | Operator |
| Write access | -        |

**Measured middle density****Navigation**

Operation → Density → Measured middle density

**Description**

Density of the middle phase.

**Additional information**

|              |          |
|--------------|----------|
| Read access  | Operator |
| Write access | -        |

**Measured lower density****Navigation**

Operation → Density → Measured lower density

**Description**

Density of the lower phase.

**Additional information**

|              |             |
|--------------|-------------|
| Read access  | Maintenance |
| Write access | -           |

**15.2.4 "Pressure" submenu**

*Navigation*       Operation → Pressure

**P1 (bottom)****Navigation**

 Operation → Pressure → P1 (bottom)

**Description**

Shows the pressure at the tank bottom.

**Additional information**

|              |          |
|--------------|----------|
| Read access  | Operator |
| Write access | -        |

**P3 (top)****Navigation**

 Operation → Pressure → P3 (top)

**Description**

Shows the pressure (P3) at the top transmitter.

**Additional information**

|              |          |
|--------------|----------|
| Read access  | Operator |
| Write access | -        |

## 15.2.5 "GP values" submenu

Navigation  Operation → GP values

---

### GP 1 to 4 name

---

**Navigation**  Operation → GP values → GP 1 name

**Description** Defines the label associated with the respective GP value.

**Factory setting** GP Value 1

**Additional information**

|              |             |
|--------------|-------------|
| Read access  | Operator    |
| Write access | Maintenance |

---

### GP Value 1

---

**Navigation**  Operation → GP values → GP Value 1

**Description** Displays the value that will be used as general purpose value.

**Additional information**

|              |          |
|--------------|----------|
| Read access  | Operator |
| Write access | -        |

---

### GP Value 2

---

**Navigation**  Operation → GP values → GP Value 2

**Description** Displays the value that will be used as general purpose value.

**Additional information**

|              |          |
|--------------|----------|
| Read access  | Operator |
| Write access | -        |

---

### GP Value 3

---

**Navigation**  Operation → GP values → GP Value 3

**Description** Displays the value that will be used as general purpose value.

**Additional information**

|              |          |
|--------------|----------|
| Read access  | Operator |
| Write access | -        |

---

**GP Value 4**

---

**Navigation** Operation → GP values → GP Value 4**Description**



Displays the value that will be used as general purpose value.

**Additional information**

|              |          |
|--------------|----------|
| Read access  | Operator |
| Write access | -        |





## 15.3 "Setup" menu

Navigation  Setup

| Device tag    |   |             |          |              |             |
|--|---|-------------|----------|--------------|-------------|
| <b>Navigation</b>  |  Setup → Device tag                                |             |          |              |             |
| <b>Description</b>   | Enter a unique name for the measuring point to identify the device quickly within the plant.  |             |          |              |             |
| <b>Factory setting</b>   | NMR8x   |             |          |              |             |
| <b>Additional information</b>  | <table border="1"> <tr> <td>Read access</td> <td>Operator</td> </tr> <tr> <td>Write access</td> <td>Maintenance</td> </tr> </table> | Read access | Operator | Write access | Maintenance |
| Read access  | Operator  |             |          |              |             |
| Write access   | Maintenance   |             |          |              |             |
| Units preset  |   |             |          |              |             |

|                               |  |             |          |              |             |
|-------------------------------|--|-------------|----------|--------------|-------------|
| <b>Navigation</b>             |  Setup → Units preset   |             |          |              |             |
| <b>Description</b>            | Defines a set of units for length, pressure and temperature.   |             |          |              |             |
| <b>Selection</b>              | <ul style="list-style-type: none"> <li>■ mm, bar, °C</li> <li>■ m, bar, °C</li> <li>■ mm, PSI, °C</li> <li>■ ft, PSI, °F</li> <li>■ ft-in-16, PSI, °F</li> <li>■ ft-in-8, PSI, °F</li> <li>■ Customer value</li> </ul> |             |          |              |             |
| <b>Factory setting</b>        | mm, bar, °C  |             |          |              |             |
| <b>Additional information</b> | <table border="1"> <tr> <td>Read access</td> <td>Operator</td> </tr> <tr> <td>Write access</td> <td>Maintenance</td> </tr> </table>  | Read access | Operator | Write access | Maintenance |
| Read access                   | Operator   |             |          |              |             |
| Write access                  | Maintenance  |             |          |              |             |

If the **Customer value** option is selected, the units are defined in the following parameters:

- Distance unit (→  228)
- Pressure unit (→  229)
- Temperature unit (→  229)
- Density unit (→  229)

In any other case these are read-only parameters used to indicate the respective unit.



**Tube diameter**



**Navigation** Setup → Tube diameter

**Description** Enter diameter of stilling well.

**User entry** Positive floating-point number

**Factory setting** 150 mm

**Additional information**

|              |             |
|--------------|-------------|
| Read access  | Operator    |
| Write access | Maintenance |

**Empty**



**Navigation** Setup → Empty

**Description** Distance from reference point to zero position (tank bottom or datum plate).

**User entry** 0 to 10 000.00 mm

**Factory setting** Dependent on the device version

**Additional information**

|              |             |
|--------------|-------------|
| Read access  | Operator    |
| Write access | Maintenance |

- The reference point is the lower edge of the device flange.
- After changing the **Empty** parameter (→ 121), the **Table mode** parameter (→ 207) is automatically set to **Disable**.
  - If **Empty** (→ 121) has been changed by more than 20 mm (0.8 in), it is recommended to delete the dip table.
  - The dip table values are not affected by a change of the **Empty** parameter (→ 121).

**Tank reference height**



**Navigation** Setup → Tank reference height

**Description** Defines the distance from the dipping reference point to the zero position (tank bottom or datum plate).

**User entry** 0 to 10 000.00 mm

**Factory setting** Dependent on the device version

**Additional information**

|              |             |
|--------------|-------------|
| Read access  | Operator    |
| Write access | Maintenance |

**Tank level**

**Navigation**

 Setup → Tank level

**Description**

Shows the distance from the zero position (tank bottom or datum plate) to the product surface.

**Additional information**

|              |          |
|--------------|----------|
| Read access  | Operator |
| Write access | -        |

**Set level**



**Navigation**

 Setup → Set level

**Description**

If the level measured by the device does not match the actual level obtained by a manual dip, enter the correct level into this parameter.

**User entry**

0 to 10 000.00 mm



**Factory setting**

0 mm

**Additional information**

|              |             |
|--------------|-------------|
| Read access  | Operator    |
| Write access | Maintenance |

The device adjusts the **Empty** parameter (→  121) according to the entered value, such that the measured level will match the actual level.

-  After the change of the **Empty** parameter (→  121), the **Table mode** parameter (→  207) is automatically set to **Disable**.
- If **Empty** has been changed by more than 20 mm (0.8 in), it is recommended to delete the dip table.
- The dip table values are not affected by a change of the **Empty** parameter.

**Confirm distance**



**Navigation**

 Setup → Confirm distance

**Description**

Specify, whether the measured distance matches the real distance. Depending on the selection the device automatically sets the range of mapping.

**Selection**

- Distance ok
- Distance unknown
- Distance too small \*
- Distance too big \*
- Tank empty
- Manual map
- Factory map

**Factory setting**

Distance unknown

**Additional information**

|              |             |
|--------------|-------------|
| Read access  | Operator    |
| Write access | Maintenance |

**Meaning of the options**

- **Distance ok**

To be selected if the measured distance matches the actual distance. The device performs a mapping.

- **Distance unknown**

To be selected if the actual distance is unknown. No mapping will be recorded in this case.

- **Distance too small** <sup>4)</sup>

To be selected if the measured distance is smaller than the actual distance. The device searches for the next echo and returns to the **Confirm distance** parameter (→  122). The distance is recalculated and displayed. The comparison must be repeated until the displayed distance matches the actual distance. After this, the recording of the map can be started by selecting "**Distance ok**" option.

- **Distance too big** <sup>4)</sup>

To be selected if the measured distance exceeds the actual distance. The device adjusts the signal evaluation and returns to the **Confirm distance** parameter (→  122). The distance is recalculated and displayed. The comparison must be repeated until the displayed distance matches the actual distance. After this, the recording of the map can be started by selecting "**Distance ok**" option.

- **Tank empty**

To be selected if the tank is completely empty. The device records a mapping covering the complete measuring range as defined by the **Empty** parameter (→  121).

- **Manual map**

To be selected if the range of mapping is to be defined manually in the **Mapping end point** parameter (→  124). In this case it is not necessary to confirm the distance.

- **Factory map**

To be selected if the present mapping curve (if one exists) is to be deleted. The factory map is used, instead.



When operating via the display module, the measured distance is displayed together with this parameter for reference purposes.



If the teaching procedure with the **Distance too small** or **Distance too big** option is quit before the distance has been confirmed, a map is **not** recorded and the teaching procedure is reset after 60 s.

\* Visibility depends on order options or device settings

4) Only available for "Evaluation mode (→  221)" = "Short time history"

---

**Present mapping**

---

**Navigation**  Setup → Present mapping

**Description** Present end of mapping.

**Additional information**

|              |          |
|--------------|----------|
| Read access  | Operator |
| Write access | -        |

---

**Mapping end point**

---



**Navigation**  Setup → Mapping end point

**Prerequisite** **Confirm distance** (→  122) = **Manual map**

**Description** Defines up to which distance the new mapping has to be recorded. Remark: Make sure the level signal is not covered by the mapping.

**User entry** 100 to 999 999.9 mm

**Factory setting** 100 mm

**Additional information**

|              |             |
|--------------|-------------|
| Read access  | Operator    |
| Write access | Maintenance |

---

**Record map**

---



**Navigation**  Setup → Record map

**Prerequisite** **Confirm distance** (→  122) = **Manual map**

**Description** Controls the recording of the map.

**Selection**



- No
- Record map
- Overlay map
- Factory map
- Delete partial map

**Factory setting** No

**Additional information**

|              |             |
|--------------|-------------|
| Read access  | Operator    |
| Write access | Maintenance |

**Meaning of the options**



- **No**  
The map is not recorded.
- **Record map**  
The map is recorded. After the recording is completed, the new measured distance and the new mapping range appear on the display. When operating via the local display, these values must be confirmed by pressing .
- **Recalculate map**  
Used internally by the software. Initiates a new calculation of the map from the new data points.
- **Overlay map**  
The new mapping curve is generated by overlaying the old and the current envelope curves.
- **Factory map**  
The factory map stored in the ROM of the device is used.
- **Delete partial map**  
The mapping curve is deleted up to **Mapping end point** (→  124).
- **Stop overlay**  
Stops the overlaying of the map.

---

**Distance**

---

**Navigation**

  Setup → Distance

**Description**

Distance from lower edge of device flange to product surface.

**Additional information**

|              |          |
|--------------|----------|
| Read access  | Operator |
| Write access | -        |

---

**Liquid temp source**

---



**Navigation**

  Setup → Liquid temp source

**Description**

Defines source from which the liquid temperature is obtained.

**Selection**

- Manual value
- HART device 1 ... 15 temperature
- AIO B1-3 value
- AIO C1-3 value
- AIP B4-8 value
- AIP C4-8 value

**Factory setting**

Manual value

**Additional information**

|              |             |
|--------------|-------------|
| Read access  | Operator    |
| Write access | Maintenance |

### 15.3.1 "Advanced setup" submenu

*Navigation*       Setup → Advanced setup

---

#### Locking status

---

**Navigation**       Setup → Advanced setup → Locking status

**Description**      Indicates the write protection with the highest priority that is currently active.

**Additional information**

|              |          |
|--------------|----------|
| Read access  | Operator |
| Write access | -        |

---

#### Access status tooling

---

**Navigation**       Setup → Advanced setup → Access status tooling

**Description**      Shows the access authorization to the parameters via the operating tool.

**Additional information**

|              |          |
|--------------|----------|
| Read access  | Operator |
| Write access | -        |

---

#### Enter access code

---

**Navigation**       Setup → Advanced setup → Enter access code

**Description**      Enter access code to disable write protection of parameters.

**Additional information**

|              |          |
|--------------|----------|
| Read access  | Operator |
| Write access | Operator |

**"Input/output" submenu**

*Navigation*       Setup → Advanced setup → Input/output

**"HART devices" submenu**

*Navigation*       Setup → Advanced setup → Input/output → HART devices

---

**Number of devices**

---

**Navigation**       Setup → Advanced setup → Input/output → HART devices → Number of devices

**Description**      Shows the number of devices on the HART bus.

**Additional information**

|                     |          |
|---------------------|----------|
| <b>Read access</b>  | Operator |
| <b>Write access</b> | -        |

*"HART Device(s)" submenu*

 There is a **HART Device(s)** submenu for each HART slave device found on the HART loop.

*Navigation*  Setup → Advanced setup → Input/output → HART devices → HART Device(s)

**Device name**

**Navigation**  Setup → Advanced setup → Input/output → HART devices → HART Device(s) → Device name

**Description** Shows the name of the transmitter.

**Additional information**

|              |          |
|--------------|----------|
| Read access  | Operator |
| Write access | -        |

**Polling address**

**Navigation**  Setup → Advanced setup → Input/output → HART devices → HART Device(s) → Polling address

**Description** Shows the polling address of the transmitter.

**Additional information**

|              |          |
|--------------|----------|
| Read access  | Operator |
| Write access | -        |

**Device tag**

**Navigation**  Setup → Advanced setup → Input/output → HART devices → HART Device(s) → Device tag

**Description** Shows the device tag of the transmitter.

**Additional information**

|              |          |
|--------------|----------|
| Read access  | Operator |
| Write access | -        |



**Operating mode**



**Navigation** Setup → Advanced setup → Input/output → HART devices → HART Device(s) → Operating mode

**Prerequisite** Not available if the HART device is a Prothermo NMT.

**Description** Selection of the operation mode PV only or PV,SV,TV,QV. Devines which values are polled from the connected HART Device.

- Selection**
- PV only
  - PV,SV,TV & QV
  - Level <sup>5)</sup>
  - Measured level <sup>5)</sup>

**Factory setting** PV,SV,TV & QV

**Additional information**

|              |             |
|--------------|-------------|
| Read access  | Operator    |
| Write access | Maintenance |

**Communication status**

**Navigation** Setup → Advanced setup → Input/output → HART devices → HART Device(s) → Communication status

**Description** Shows the operating status of the transmitter.

- User interface**
- Operating normally
  - Device offline

**Additional information**

|              |          |
|--------------|----------|
| Read access  | Operator |
| Write access | -        |

**#blank# ( HART PV - designation dependent on device)**

**Navigation** Setup → Advanced setup → Input/output → HART devices → HART Device(s) → #blank#



**Description** Shows the first HART variable (PV).

**Additional information**



|              |          |
|--------------|----------|
| Read access  | Operator |
| Write access | -        |

5) only visible if the conneced device is a Micropilot



**#blank# (HART SV - designation dependent on device)**

|                               |   |             |          |              |   |
|-------------------------------|---|-------------|----------|--------------|---|
| <b>Navigation</b>             |   Setup → Advanced setup → Input/output → HART devices → HART Device(s) → #blank# |             |          |              |   |
| <b>Prerequisite</b>           | For HART devices other than NMT: <b>Operating mode</b> (→  129) = PV,SV,TV & QV  |             |          |              |   |
| <b>Description</b>            | Shows the second HART variable (SV).  |             |          |              |   |
| <b>Additional information</b> | <table border="1"> <tr> <td>Read access</td> <td>Operator</td> </tr> <tr> <td>Write access</td> <td>-</td> </tr> </table>   | Read access | Operator | Write access | - |
| Read access                   | Operator  |             |          |              |   |
| Write access                  | -   |             |          |              |   |



**#blank# (HART TV - designation dependent on device)**

|                               |   |             |          |              |   |
|-------------------------------|---|-------------|----------|--------------|---|
| <b>Navigation</b>             |   Setup → Advanced setup → Input/output → HART devices → HART Device(s) → #blank# |             |          |              |   |
| <b>Prerequisite</b>           | For HART devices other than NMT: <b>Operating mode</b> (→  129) = PV,SV,TV & QV  |             |          |              |   |
| <b>Description</b>            | Shows the third HART variable (TV).   |             |          |              |   |
| <b>Additional information</b> | <table border="1"> <tr> <td>Read access</td> <td>Operator</td> </tr> <tr> <td>Write access</td> <td>-</td> </tr> </table>   | Read access | Operator | Write access | - |
| Read access                   | Operator  |             |          |              |   |
| Write access                  | -   |             |          |              |   |

**#blank# (HART QV - designation dependent on device)**

|                               |   |             |          |              |   |
|-------------------------------|---|-------------|----------|--------------|---|
| <b>Navigation</b>             |   Setup → Advanced setup → Input/output → HART devices → HART Device(s) → #blank# |             |          |              |   |
| <b>Prerequisite</b>           | For HART devices other than NMT: <b>Operating mode</b> (→  129) = PV,SV,TV & QV  |             |          |              |   |
| <b>Description</b>            | Shows the fourth HART variable (QV).  |             |          |              |   |
| <b>Additional information</b> | <table border="1"> <tr> <td>Read access</td> <td>Operator</td> </tr> <tr> <td>Write access</td> <td>-</td> </tr> </table>   | Read access | Operator | Write access | - |
| Read access                   | Operator  |             |          |              |   |
| Write access                  | -   |             |          |              |   |

**Output pressure**

|                     |   |
|---------------------|---|
| <b>Navigation</b>   |   Setup → Advanced setup → Input/output → HART devices → HART Device(s) → Output pressure |
| <b>Prerequisite</b> | Not available for Micropilot S FMR5xx and Prothermo 53x. (In these cases the measured variables are allocated automatically).   |

**Description** Defines which HART variable is the pressure.

**Selection**

- No value
- Primary variable (PV)
- Secondary variable (SV)
- Tertiary variable (TV)
- Quaternary variable (QV)



**Factory setting** No value

**Additional information**

|              |             |
|--------------|-------------|
| Read access  | Operator    |
| Write access | Maintenance |

---

## Output density

**Navigation**   Setup → Advanced setup → Input/output → HART devices → HART Device(s) → Output density

**Prerequisite** Not available for Micropilot S FMR5xx and Prothermo 53x. (In these cases the measured variables are allocated automatically).

**Description** Defines which HART variable is the density.

**Selection**

- No value
- Primary variable (PV)
- Secondary variable (SV)
- Tertiary variable (TV)
- Quaternary variable (QV)



**Factory setting** No value

**Additional information**

|              |             |
|--------------|-------------|
| Read access  | Operator    |
| Write access | Maintenance |

---

## Output temperature

**Navigation**   Setup → Advanced setup → Input/output → HART devices → HART Device(s) → Output temperature

**Prerequisite** Not available for Micropilot S FMR5xx and Prothermo 53x. (In these cases the measured variables are allocated automatically).

**Description** Defines which HART variable is the temperature.

**Selection**

- No value
- Primary variable (PV)
- Secondary variable (SV)
- Tertiary variable (TV)
- Quaternary variable (QV)

**Factory setting** No value

**Additional information**

|              |             |
|--------------|-------------|
| Read access  | Operator    |
| Write access | Maintenance |

---

**Output vapor temperature**



**Navigation**

Setup → Advanced setup → Input/output → HART devices → HART Device(s)  
→ Output vapor temperature

**Prerequisite**

Not available for Micropilot S FMR5xx and Prothermo 53x. (In these cases the measured variables are allocated automatically).

**Description**

Defines which HART variable is the vapor temperature.

**Selection**

- No value
- Primary variable (PV)
- Secondary variable (SV)
- Tertiary variable (TV)
- Quaternary variable (QV)

**Factory setting**

No value

**Additional information**

|              |             |
|--------------|-------------|
| Read access  | Operator    |
| Write access | Maintenance |

---

**Output level**



**Navigation**

Setup → Advanced setup → Input/output → HART devices → HART Device(s)  
→ Output level

**Prerequisite**

Not available for Micropilot S FMR5xx and Prothermo 53x. (In these cases the measured variables are allocated automatically).

**Description**

Defines which HART variable is the level.

**Selection**

- No value
- Primary variable (PV)
- Secondary variable (SV)
- Tertiary variable (TV)
- Quaternary variable (QV)

**Factory setting**

No value



**Additional information**

|              |             |
|--------------|-------------|
| Read access  | Operator    |
| Write access | Maintenance |

"Forget device" wizard



|             |             |
|-------------|-------------|
| Read access | Maintenance |
|-------------|-------------|

 This submenu is only visible if **Number of devices** (→  127) ≥ 1.

Navigation   Setup → Advanced setup → Input/output → HART devices → Forget device

Forget device



Navigation   Setup → Advanced setup → Input/output → HART devices → Forget device → Forget device

Description With this function an offline device can be deleted from the device list.

- Selection
- HART Device 1 \*
  - HART Device 2 \*
  - HART Device 3 \*
  - HART Device 4 \*
  - HART Device 5 \*
  - HART Device 6 \*
  - HART Device 7 \*
  - HART Device 8 \*
  - HART Device 9 \*
  - HART Device 10 \*
  - HART Device 11 \*
  - HART Device 12 \*
  - HART Device 13 \*
  - HART Device 14 \*
  - HART Device 15 \*
  - None

Factory setting None

Additional information

|              |             |
|--------------|-------------|
| Read access  | Operator    |
| Write access | Maintenance |

\* Visibility depends on order options or device settings

"Analog IP" submenu

**i** There is a **Analog IP** submenu for each Analog I/O module of the device. This submenu refers to terminals 4 to 8 of this module (the analog input). They are primarily used to connect an RTD. For terminals 1 to 3 (analog input or output) refer to → 140.

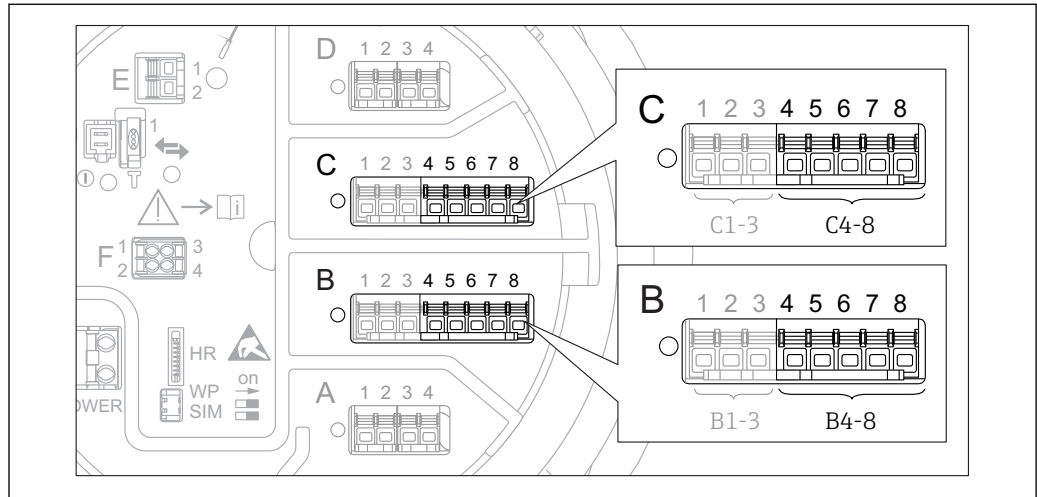

43 Terminals for the "Analog IP" submenu ("B4-8" or "C4-8", respectively)

Navigation Setup → Advanced setup → Input/output → Analog IP

Operating mode

Navigation Setup → Advanced setup → Input/output → Analog IP → Operating mode

Description Defines the operating mode of the analog input.

- Selection
- Disabled
  - RTD temperature input
  - Gauge power supply

Factory setting Disabled

Additional information

|              |             |
|--------------|-------------|
| Read access  | Operator    |
| Write access | Maintenance |

RTD type

Navigation Setup → Advanced setup → Input/output → Analog IP → RTD type

Prerequisite **Operating mode** (→ 134) = **RTD temperature input**

Description Defines the type of the connected RTD.

- Selection**
- Cu50 (w=1.428, GOST)
  - Cu53 (w=1.426, GOST)
  - Cu90; 0°C (w=1.4274, GOST)
  - Cu100; 25°C (w=1.4274, GOST)
  - Cu100; 0°C(w=1.4274, GOST)
  - Pt46 (w=1.391, GOST)
  - Pt50 (w=1.391, GOST)
  - Pt100(385) (a=0.00385, IEC751)
  - Pt100(389) (a=0.00389, Canadian)
  - Pt100(391) (a=0.003916, JIS1604)
  - Pt100 (w=1.391, GOST)
  - Pt500(385) (a=0.00385, IEC751)
  - Pt1000(385) (a=0.00385, IEC751)
  - Ni100(617) (a=0.00617, DIN43760)
  - Ni120(672) (a=0.00672, DIN43760)
  - Ni1000(617) (a=0.00617, DIN43760)

**Factory setting** Pt100(385) (a=0.00385, IEC751)

**Additional information**

|              |             |
|--------------|-------------|
| Read access  | Operator    |
| Write access | Maintenance |

**RTD connection type**



**Navigation** Setup → Advanced setup → Input/output → Analog IP → RTD connection type

**Prerequisite** **Operating mode (→ 134) = RTD temperature input**

**Description** Defines the connection type of the RTD.

- Selection**
- 4 wire RTD connection
  - 2 wire RTD connection
  - 3 wire RTD connection

**Factory setting** 4 wire RTD connection

**Additional information**

|              |             |
|--------------|-------------|
| Read access  | Operator    |
| Write access | Maintenance |

**Process value**

**Navigation** Setup → Advanced setup → Input/output → Analog IP → Process value

**Prerequisite** **Operating mode (→ 134) ≠ Disabled**

**Description** Shows the measured value received via the analog input.

**Additional information**

|              |          |
|--------------|----------|
| Read access  | Operator |
| Write access | -        |

**Process variable****Navigation**

Setup → Advanced setup → Input/output → Analog IP → Process variable

**Prerequisite**

**Operating mode (→ 134) ≠ RTD temperature input**

**Description**

Determines type of measured value.

**Selection**

- Level linearized
- Temperature
- Pressure
- Density

**Factory setting**

Level linearized

**Additional information**

|              |             |
|--------------|-------------|
| Read access  | Operator    |
| Write access | Maintenance |

**0 % value****Navigation**

Setup → Advanced setup → Input/output → Analog IP → 0 % value

**Prerequisite**

**Operating mode (→ 134) = 4..20mA input**

**Description**

Defines the value represented by a current of 4mA.

**User entry**

-100 000 to 100 000 mm

**Factory setting**

0 mm

**Additional information**

|              |             |
|--------------|-------------|
| Read access  | Operator    |
| Write access | Maintenance |

**100 % value****Navigation**

Setup → Advanced setup → Input/output → Analog IP → 100 % value

**Prerequisite**

**Operating mode (→ 134) = 4..20mA input**

**Description**

Defines the value represented by a current of 20mA.



**User entry** -100 000 to 100 000 mm

**Factory setting** 0 mm

**Additional information**

|              |             |
|--------------|-------------|
| Read access  | Operator    |
| Write access | Maintenance |

**Input value**

**Navigation**   Setup → Advanced setup → Input/output → Analog IP → Input value

**Prerequisite** **Operating mode (→  134) ≠ Disabled**



**Description** Shows the value received via the analog input.

**Additional information**

|              |          |
|--------------|----------|
| Read access  | Operator |
| Write access | -        |

**Minimum probe temperature**



**Navigation**   Setup → Advanced setup → Input/output → Analog IP → Minimum probe temperature

**Prerequisite** **Operating mode (→  134) = RTD temperature input**

**Description** Minimum approved temperature of the connected probe. If the temperature falls below this value, the W&M status will be 'invalid'.

**User entry** -213 to 927 °C

**Factory setting** -100 °C

**Additional information**

|              |             |
|--------------|-------------|
| Read access  | Operator    |
| Write access | Maintenance |

**Maximum probe temperature**



**Navigation**   Setup → Advanced setup → Input/output → Analog IP → Maximum probe temperature

**Prerequisite** **Operating mode (→  134) = RTD temperature input**

**Description** Maximum approved temperature of the connected probe. If the temperature rises above this value, the W&M status will be 'invalid'.

**User entry** -213 to 927 °C

**Factory setting** 250 °C

**Additional information**

|              |             |
|--------------|-------------|
| Read access  | Operator    |
| Write access | Maintenance |

---

**Probe position** 

---

**Navigation**   Setup → Advanced setup → Input/output → Analog IP → Probe position

**Prerequisite** **Operating mode (→  134) = RTD temperature input**

**Description** Position of the temperature probe, measured from zero position (tank bottom or datum plate). This parameter, in conjunction with the measured level, determines whether the temperature probe is still covered by the product. If this is no longer the case, the status of the temperature value will be 'invalid'.

**User entry** -5 000 to 30 000 mm

**Factory setting** 5 000 mm

**Additional information**

|              |             |
|--------------|-------------|
| Read access  | Operator    |
| Write access | Maintenance |

---

**Damping factor** 

---

**Navigation**   Setup → Advanced setup → Input/output → Analog IP → Damping factor

**Prerequisite** **Operating mode (→  134) ≠ Disabled**

**Description** Defines the damping constant (in seconds).

**User entry** 0 to 999.9 s

**Factory setting** 0 s



**Additional information**

|              |             |
|--------------|-------------|
| Read access  | Operator    |
| Write access | Maintenance |

---

**Gauge current**

---

**Navigation** Setup → Advanced setup → Input/output → Analog IP → Gauge current**Prerequisite****Operating mode (→  134) = Gauge power supply****Description**

Shows the current on the power supply line for the connected device.

**Additional information**

|              |          |
|--------------|----------|
| Read access  | Operator |
| Write access | -        |

"Analog I/O" submenu

**i** There is a **Analog I/O** submenu for each Analog I/O module of the device. This submenu refers to terminals 1 to 3 of this module (an analog input or output). For terminals 4 to 8 (always an analog input) refer to → 134.

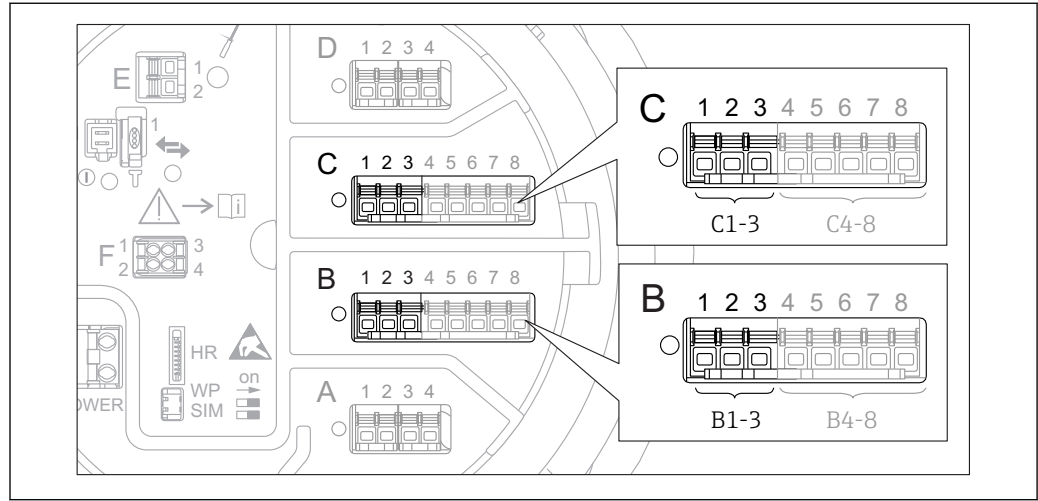

44 Terminals for the "Analog I/O" submenu ("B1-3" or "C1-3", respectively)

Navigation Setup → Advanced setup → Input/output → Analog I/O

Operating mode

Navigation Setup → Advanced setup → Input/output → Analog I/O → Operating mode

Description Defines the operating mode of the analog I/O module.

- Selection
- Disabled
  - 4..20mA input
  - HART master+4..20mA input
  - HART master
  - 4..20mA output
  - HART slave +4..20mA output

Factory setting Disabled

Additional information

|              |             |
|--------------|-------------|
| Read access  | Operator    |
| Write access | Maintenance |

Meaning of the options

| Operating mode (→ 140)    | Direction of signal                 | Type of signal  |
|---------------------------|-------------------------------------|---|
| Disabled                  | -                                   | -   |
| 4..20mA input             | Input from 1 external device        | Analog (4...20mA)   |
| HART master+4..20mA input | Input from 1 external device        | <ul style="list-style-type: none"> <li>▪ Analog (4...20mA)</li> <li>▪ HART</li> </ul> |
| HART master               | Input from up to 6 external devices | HART  |



| Operating mode (→ ⓘ 140)    | Direction of signal         | Type of signal  |
|-----------------------------|-----------------------------|---|
| 4...20mA output             | Output to higher-level unit | Analog (4...20mA)   |
| HART slave +4...20mA output | Output to higher-level unit | <ul style="list-style-type: none"> <li>■ Analog (4...20mA)</li> <li>■ HART</li> </ul> |

Depending on the terminals used, the Analog I/O module is used in the passive or active mode.

| Mode  | Terminals of the I/O module |   |          |
|---|-----------------------------|---|----------|
|   | 1                           | 2 | 3        |
| Passive<br>(power supply from external source)  | -                           | + | not used |
| Active<br>(power supplied by the device itself) | not used                    | - | +        |

-  In the active mode the following conditions must be met:
- Maximum current consumption of the connected HART devices: 24 mA (i.e. 4 mA per device if 6 devices are connected).
  - Output voltage of the Ex-d module: 17.0 V@4 mA to 10.5 V@22 mA
  - Output voltage of the Ex-ia module: 18.5 V@4 mA to 12.5 V@22 mA

## Current span

|                               |   |                    |          |                     |             |
|-------------------------------|---|--------------------|----------|---------------------|-------------|
| <b>Navigation</b>             |   Setup → Advanced setup → Input/output → Analog I/O → Current span |                    |          |                     |             |
| <b>Prerequisite</b>           | <b>Operating mode</b> parameter (→ ⓘ 140) ≠ <b>Disabled</b> option or <b>HART master</b> option   |                    |          |                     |             |
| <b>Description</b>            | Defines the current range for the measured value transmission.  |                    |          |                     |             |
| <b>Selection</b>              | <ul style="list-style-type: none"> <li>■ 4...20 mA NAMUR</li> <li>■ 4...20 mA US</li> <li>■ 4...20 mA</li> <li>■ Fixed current *</li> </ul>   |                    |          |                     |             |
| <b>Factory setting</b>        | 4...20 mA NAMUR   |                    |          |                     |             |
| <b>Additional information</b> | <table border="1" style="width: 100%; border-collapse: collapse;"> <tr> <td style="width: 50%;"><b>Read access</b></td> <td>Operator</td> </tr> <tr> <td><b>Write access</b></td> <td>Maintenance</td> </tr> </table>                     | <b>Read access</b> | Operator | <b>Write access</b> | Maintenance |
| <b>Read access</b>            | Operator  |                    |          |                     |             |
| <b>Write access</b>           | Maintenance   |                    |          |                     |             |

### Meaning of the options

| Option          | Current range for process variable | Lower alarm signal level | Upper alarm signal level |
|-----------------|------------------------------------|--------------------------|--------------------------|
| 4...20 mA       | 4 to 20.5 mA                       | < 3.6 mA                 | > 21.95 mA               |
| 4...20 mA NAMUR | 3.8 to 20.5 mA                     | < 3.6 mA                 | > 21.95 mA               |

\* Visibility depends on order options or device settings

| Option        | Current range for process variable   | Lower alarm signal level | Upper alarm signal level |
|---------------|--|--------------------------|--------------------------|
| 4...20 mA US  | 3.9 to 20.8 mA   | < 3.6 mA                 | > 21.95 mA               |
| Fixed current | Constant current, defined in the <b>Fixed current</b> parameter (→ ⓘ 142). |                          |                          |

 In the case of an error, the output current assumes the value defined in the **Failure mode** parameter (→ ⓘ 143).

**Fixed current** 

**Navigation**

  Setup → Advanced setup → Input/output → Analog I/O → Fixed current

**Prerequisite**

**Current span (→ ⓘ 141) = Fixed current**

**Description**

Defines the fixed output current.

**User entry**

4 to 22.5 mA

**Factory setting**



4 mA

**Additional information**

|              |             |
|--------------|-------------|
| Read access  | Operator    |
| Write access | Maintenance |

**Analog input source** 

**Navigation**

  Setup → Advanced setup → Input/output → Analog I/O → Analog input source

**Prerequisite**

- **Operating mode (→ ⓘ 140) = 4..20mA output or HART slave +4..20mA output**
- **Current span (→ ⓘ 141) ≠ Fixed current**

**Description**

Defines the process variable transmitted via the AIO.

**Selection**

- None
- Tank level
- Tank level %
- Tank ullage
- Tank ullage %
- Measured level
- Distance
- Displacer position
- Water level
- Upper interface level
- Lower interface level
- Bottom level
- Tank reference height
- Liquid temperature
- Vapor temperature
- Air temperature

- Observed density value
- Average profile density <sup>6)</sup>
- Upper density
- Middle density
- Lower density
- P1 (bottom)
- P2 (middle)
- P3 (top)
- GP 1 ... 4 value
- AIO B1-3 value <sup>6)</sup>
- AIO B1-3 value mA <sup>6)</sup>
- AIO C1-3 value <sup>6)</sup>
- AIO C1-3 value mA <sup>6)</sup>
- AIP B4-8 value <sup>6)</sup>
- AIP C4-8 value <sup>6)</sup>
- Element temperature 1 ... 24 <sup>6)</sup>
- HART device 1...15 PV <sup>6)</sup>
- HART device 1 ... 15 PV mA <sup>6)</sup>
- HART device 1 ... 15 PV % <sup>6)</sup>
- HART device 1 ... 15 SV <sup>6)</sup>
- HART device 1 ... 15 TV <sup>6)</sup>
- HART device 1 ... 15 QV <sup>6)</sup>

**Factory setting**

Tank level

**Additional information**

|              |             |
|--------------|-------------|
| Read access  | Operator    |
| Write access | Maintenance |

---

**Failure mode**



**Navigation**

Setup → Advanced setup → Input/output → Analog I/O → Failure mode

**Prerequisite**

**Operating mode (→ 140) = 4..20mA output or HART slave +4..20mA output**

**Description**

Defines the output behavior in case of an error.

**Selection**

- Min.
- Max.
- Last valid value
- Actual value
- Defined value

**Factory setting**

Max.

**Additional information**

|              |             |
|--------------|-------------|
| Read access  | Operator    |
| Write access | Maintenance |

---

<sup>6)</sup> Visibility depends on order options or device settings

**Error value** 

**Navigation**   Setup → Advanced setup → Input/output → Analog I/O → Error value

**Prerequisite** **Failure mode (→  143) = Defined value**

**Description** Defines the output value in case of an error.



**User entry** 3.4 to 22.6 mA

**Factory setting** 22 mA



**Additional information**

|              |             |
|--------------|-------------|
| Read access  | Operator    |
| Write access | Maintenance |

**Input value**

**Navigation**   Setup → Advanced setup → Input/output → Analog I/O → Input value

**Prerequisite**



- **Operating mode (→  140) = 4..20mA output or HART slave +4..20mA output**
- **Current span (→  141) ≠ Fixed current**

**Description** Shows the input value of the analog I/O module.



**Additional information**

|              |          |
|--------------|----------|
| Read access  | Operator |
| Write access | -        |

**0 % value** 

**Navigation**   Setup → Advanced setup → Input/output → Analog I/O → 0 % value

**Prerequisite**

- **Operating mode (→  140) = 4..20mA output or HART slave +4..20mA output**
- **Current span (→  141) ≠ Fixed current**

**Description** Value corresponding to an output current of 0% (4mA).

**User entry** Signed floating-point number

**Factory setting** 0 Unitless

**Additional information**

|              |             |
|--------------|-------------|
| Read access  | Operator    |
| Write access | Maintenance |



**100 % value**



|                               |   |             |          |              |             |
|-------------------------------|---|-------------|----------|--------------|-------------|
| <b>Navigation</b>             | ☰☰ Setup → Advanced setup → Input/output → Analog I/O → 100 % value   |             |          |              |             |
| <b>Prerequisite</b>           | <ul style="list-style-type: none"> <li>▪ <b>Operating mode</b> (→ ☰ 140) = 4..20mA output or HART slave +4..20mA output</li> <li>▪ <b>Current span</b> (→ ☰ 141) ≠ Fixed current</li> </ul>             |             |          |              |             |
| <b>Description</b>            | Value corresponding to an output current of 100% (20mA).  |             |          |              |             |
| <b>User entry</b>             | Signed floating-point number  |             |          |              |             |
| <b>Factory setting</b>        | 0 Unitless  |             |          |              |             |
| <b>Additional information</b> | <table border="1" style="width: 100%; border-collapse: collapse;"> <tr> <td style="width: 50%;">Read access</td> <td>Operator</td> </tr> <tr> <td>Write access</td> <td>Maintenance</td> </tr> </table> | Read access | Operator | Write access | Maintenance |
| Read access                   | Operator  |             |          |              |             |
| Write access                  | Maintenance   |             |          |              |             |

**Input value %**

|                               |   |             |          |              |   |
|-------------------------------|---|-------------|----------|--------------|---|
| <b>Navigation</b>             | ☰☰ Setup → Advanced setup → Input/output → Analog I/O → Input value %   |             |          |              |   |
| <b>Prerequisite</b>           | <ul style="list-style-type: none"> <li>▪ <b>Operating mode</b> (→ ☰ 140) = 4..20mA output or HART slave +4..20mA output</li> <li>▪ <b>Current span</b> (→ ☰ 141) ≠ Fixed current</li> </ul>   |             |          |              |   |
| <b>Description</b>            | Shows the output value as a percentage of the complete 4...20mA range.  |             |          |              |   |
| <b>Additional information</b> | <table border="1" style="width: 100%; border-collapse: collapse;"> <tr> <td style="width: 50%;">Read access</td> <td>Operator</td> </tr> <tr> <td>Write access</td> <td>-</td> </tr> </table> | Read access | Operator | Write access | - |
| Read access                   | Operator  |             |          |              |   |
| Write access                  | -   |             |          |              |   |

**Output value**

|                               |   |             |          |              |   |
|-------------------------------|---|-------------|----------|--------------|---|
| <b>Navigation</b>             | ☰☰ Setup → Advanced setup → Input/output → Analog I/O → Output value  |             |          |              |   |
| <b>Prerequisite</b>           | <b>Operating mode</b> (→ ☰ 140) = 4..20mA output or HART slave +4..20mA output  |             |          |              |   |
| <b>Description</b>            | Shows the output value in mA.   |             |          |              |   |
| <b>Additional information</b> | <table border="1" style="width: 100%; border-collapse: collapse;"> <tr> <td style="width: 50%;">Read access</td> <td>Operator</td> </tr> <tr> <td>Write access</td> <td>-</td> </tr> </table> | Read access | Operator | Write access | - |
| Read access                   | Operator  |             |          |              |   |
| Write access                  | -   |             |          |              |   |

**Process variable**



- Navigation** Setup → Advanced setup → Input/output → Analog I/O → Process variable
- Prerequisite** **Operating mode (→ 140) = 4..20mA input or HART master+4..20mA input**
- Description** Defines the type of measuring variable.
- Selection**
- Level linearized
  - Temperature
  - Pressure
  - Density
- Factory setting** Level linearized

**Additional information**

|              |             |
|--------------|-------------|
| Read access  | Operator    |
| Write access | Maintenance |

**Analog input 0% value**



- Navigation** Setup → Advanced setup → Input/output → Analog I/O → Analog input 0% value
- Prerequisite** **Operating mode (→ 140) = 4..20mA input or HART master+4..20mA input**
- Description** Value corresponding to an input current of 0% (4mA).
- User entry** -100 000 to 100 000 mm
- Factory setting** 0 mm

**Additional information**

|              |             |
|--------------|-------------|
| Read access  | Operator    |
| Write access | Maintenance |

**Analog input 100% value**



- Navigation** Setup → Advanced setup → Input/output → Analog I/O → Analog input 100% value
- Prerequisite** **Operating mode (→ 140) = 4..20mA input or HART master+4..20mA input**
- Description** Value corresponding to an input current of 100% (20mA).
- User entry** -100 000 to 100 000 mm
- Factory setting** 0 mm

**Additional information**

|              |             |
|--------------|-------------|
| Read access  | Operator    |
| Write access | Maintenance |

**Error event type**



**Navigation**

Setup → Advanced setup → Input/output → Analog I/O → Error event type

**Prerequisite**

**Operating mode (→ 140) ≠ Disabled or HART master**

**Description**

Defines the type of event message (alarm/warning) in case of an error or output out of range in the analog I/O module.

**Selection**

- None
- Warning
- Alarm

**Factory setting**

Warning

**Additional information**

|              |             |
|--------------|-------------|
| Read access  | Operator    |
| Write access | Maintenance |

**Process value**

**Navigation**

Setup → Advanced setup → Input/output → Analog I/O → Process value

**Prerequisite**

**Operating mode (→ 140) = 4..20mA input or HART master+4..20mA input**

**Description**

Shows the input value scaled to customer units.

**Additional information**

|              |          |
|--------------|----------|
| Read access  | Operator |
| Write access | -        |

**Input value in mA**

**Navigation**

Setup → Advanced setup → Input/output → Analog I/O → Input value in mA

**Prerequisite**

**Operating mode (→ 140) = 4..20mA input or HART master+4..20mA input**

**Description**

Shows the input value in mA.

**Additional information**

|              |          |
|--------------|----------|
| Read access  | Operator |
| Write access | -        |

**Input value percent**

**Navigation**  Setup → Advanced setup → Input/output → Analog I/O → Input value percent

**Prerequisite** **Operating mode (→  140) = 4..20mA input or HART master+4..20mA input**

**Description** Shows the input value as a percentage of the complete 4...20mA current range.

**Additional information**

|              |          |
|--------------|----------|
| Read access  | Operator |
| Write access | -        |

**Damping factor**



**Navigation**  Setup → Advanced setup → Input/output → Analog I/O → Damping factor

**Prerequisite** **Operating mode (→  140) ≠ Disabled or HART master**

**Description** Defines the damping constant (in seconds).

**User entry** 0 to 999.9 s

**Factory setting** 0 s

**Additional information**

|              |             |
|--------------|-------------|
| Read access  | Operator    |
| Write access | Maintenance |

**Used for SIL/WHG**



**Navigation**  Setup → Advanced setup → Input/output → Analog I/O → Used for SIL/WHG

**Prerequisite**

- **Operating mode (→  140) = 4..20mA output or HART slave +4..20mA output**
- The device has a SIL approval.

**Description** Determines whether the discrete I/O module is in SIL/WHG mode.

**Selection**

- Enabled
- Disabled

**Factory setting** Disabled

**Additional information**

|              |             |
|--------------|-------------|
| Read access  | Operator    |
| Write access | Maintenance |

---

**Expected SIL/WHG chain**

---

**Navigation**

 Setup → Advanced setup → Input/output → Analog I/O → Expected SIL/WHG chain

**Prerequisite**

- **Operating mode (→  140) = 4..20mA output or HART slave +4..20mA output**
- The device has a SIL approval.

**Additional information**

|              |          |
|--------------|----------|
| Read access  | Operator |
| Write access | -        |

"Digital Xx-x" submenu

- i
  - In the operating menu, each digital input or output is designated by the respective slot of the terminal compartment and two terminals within this slot. **A1-2**, for example, denotes terminals 1 and 2 of slot **A**. The same is valid for slots **B**, **C** and **D** if they contain a Digital IO module.
  - In this document, **Xx-x** designates any of these submenus. The structure of all these submenus is the same.

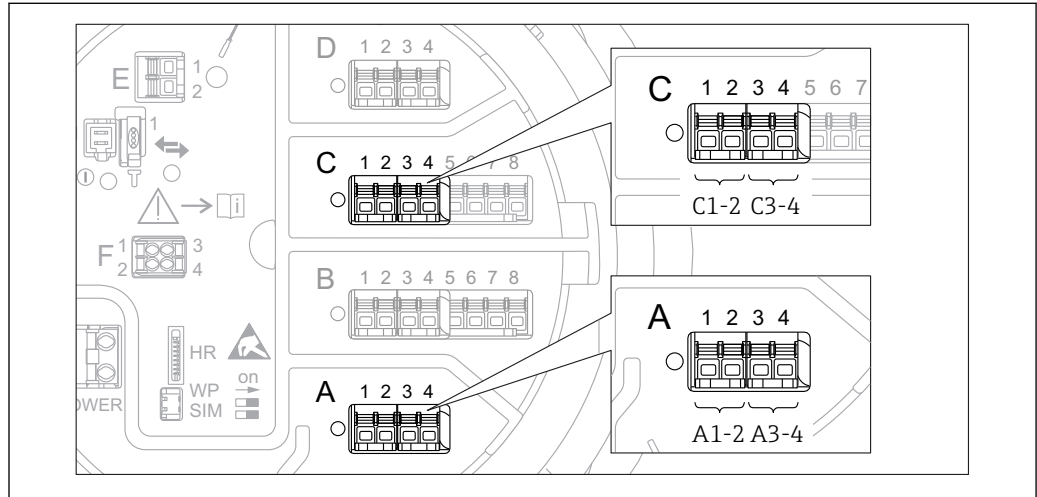

45 Designation of the digital inputs or outputs (examples)

Navigation Setup → Advanced setup → Input/output → Digital Xx-x

Operating mode

|                        |   |
|------------------------|---|
| <b>Navigation</b>      | Setup → Advanced setup → Input/output → Digital Xx-x → Operating mode   |
| <b>Description</b>     | Defines the operating mode of the discrete I/O module.  |
| <b>Selection</b>       | <ul style="list-style-type: none"> <li>▪ Disabled</li> <li>▪ Output passive</li> <li>▪ Input passive</li> <li>▪ Input active</li> </ul> |
| <b>Factory setting</b> | Disabled  |

**Additional information**

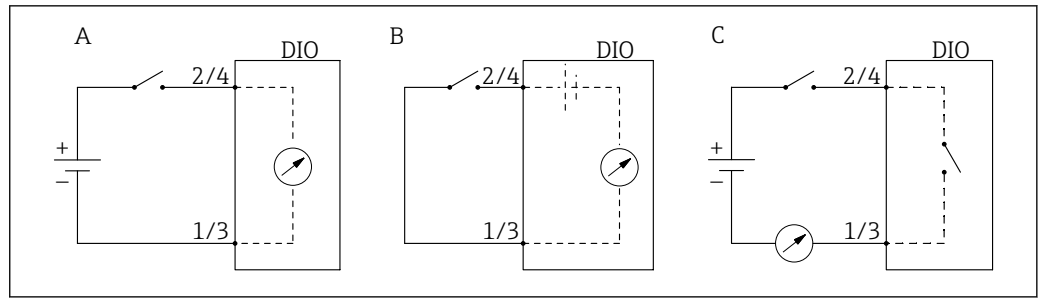

46 Operating modes of the Digital I/O module

- A Input passive
- B Input active
- C Output passive

A0033028

**Digital input source**



**Navigation**

Setup → Advanced setup → Input/output → Digital Xx-x → Digital input source

**Prerequisite**

Operating mode (→ 150) = Output passive

**Description**

Defines which device state is indicated by the digital output.

**Selection**

- None
- Alarm x any
- Alarm x High
- Alarm x HighHigh
- Alarm x High or HighHigh
- Alarm x Low
- Alarm x LowLow
- Alarm x Low or LowLow
- Digital Xx-x
- Pri. Modbus x
- Sec. Modbus x

**Factory setting**

None

**Additional information**

**Meaning of the options**

- Alarm x any, Alarm x High, Alarm x HighHigh, Alarm x High or HighHigh, Alarm x Low, Alarm x LowLow, Alarm x Low or LowLow

The digital output indicates if the selected alarm is currently active. The alarms themselves are defined in the **Alarm 1 to 4** submenus.

- Digital Xx-x<sup>7)</sup>

The digital signal present at the digital input Xx-x is passed through to the digital output.



- Modbus A1-4 Discrete x
- Modbus B1-4 Discrete x
- Modbus C1-4 Discrete x
- Modbus D1-4 Discrete x

The digital value written by the Modbus Master device to the **Modbus discrete x** parameter<sup>8)</sup> is passed to the digital output. For details refer to Special Documentation SD02066G.

7) Only present if "Operating mode (→ 150)" = "Input passive" or "Input active" for the respective Digital I/O module.

8) Expert → Communication → Modbus Xx-x → Modbus discrete x

**Input value**



- Navigation**  Setup → Advanced setup → Input/output → Digital Xx-x → Input value
- Prerequisite** **Operating mode (→  150) = "Input passive" option or "Input active" option**
- Description** Shows the digital input value.

**Additional information**

|              |          |
|--------------|----------|
| Read access  | Operator |
| Write access | -        |



**Contact type**



- Navigation**  Setup → Advanced setup → Input/output → Digital Xx-x → Contact type
- Prerequisite** **Operating mode (→  150) ≠ Disabled**
- Description** Determines the switching behavior of the input or output.
- Selection**
  - Normally open
  - Normally closed
- Factory setting** Normally open

**Output simulation**



- Navigation**  Setup → Advanced setup → Input/output → Digital Xx-x → Output simulation
- Prerequisite** **Operating mode (→  150) = Output passive**
- Description** Sets the output to a specific simulated value.
- Selection**
  - Disable
  - Simulating active
  - Simulating inactive
  - Fault 1
  - Fault 2
- Factory setting** Disable

**Additional information**

|              |             |
|--------------|-------------|
| Read access  | Operator    |
| Write access | Maintenance |

The digital output consists of two relays connected in series:



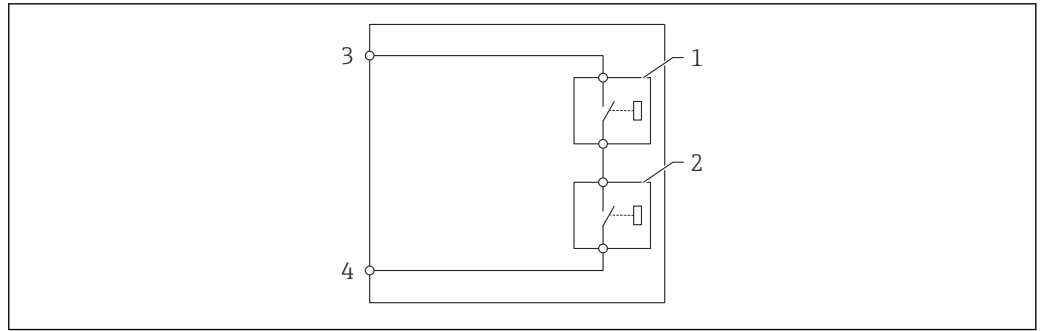

A0028602

47 The two relays of a digital output

1/2 The relays

3/4 The terminals of the digital output

The switching state of these relays is defined by the **Output simulation** parameter as follows:

| Output simulation   | State of relay 1 | State of relay 2 | Expected result on the terminals of the I/O module |
|---------------------|------------------|------------------|--|
| Simulating active   | Closed           | Closed           | Closed   |
| Simulating inactive | Open             | Open             | Open   |
| Fault 1             | Closed           | Open             | Open   |
| Fault 2             | Open             | Closed           | Open   |

**i** The **Fault 1** and **Fault 2** options can be used to check the correct switching behavior of the two relays.

---

**Output value**

---

**Navigation**                      Setup → Advanced setup → Input/output → Digital Xx-x → Output values

**Prerequisite**                      **Operating mode (→ 150) = Output passive**

**Description**                      Shows the digital output value.

**Additional information**

|              |          |
|--------------|----------|
| Read access  | Operator |
| Write access | -        |

---

**Readback value**

---

**Navigation**                      Setup → Advanced setup → Input/output → Digital Xx-x → Readback value

**Prerequisite**                      **Operating mode (→ 150) = Output passive**

**Description**                      Shows the value read back from the output.

**Additional information**

|              |          |
|--------------|----------|
| Read access  | Operator |
| Write access | -        |

**Used for SIL/WHG****Navigation**

Setup → Advanced setup → Input/output → Digital Xx-x → Used for SIL/WHG

**Prerequisite**

- **Operating mode (→ 150) = Output passive**
- The device has a SIL certificate.

**Description**

Determines whether the discrete I/O module is in SIL/WHG mode.

**Selection**

- Enabled
- Disabled

**Factory setting**

Disabled

**Additional information**

|              |             |
|--------------|-------------|
| Read access  | Operator    |
| Write access | Maintenance |

**"Communication" submenu**

This menu contains a submenu for each digital communication interface of the device. The communication interfaces are designated by "X1-4" where "X" specifies the slot in the terminal compartment and "1-4" the terminals within this slot.

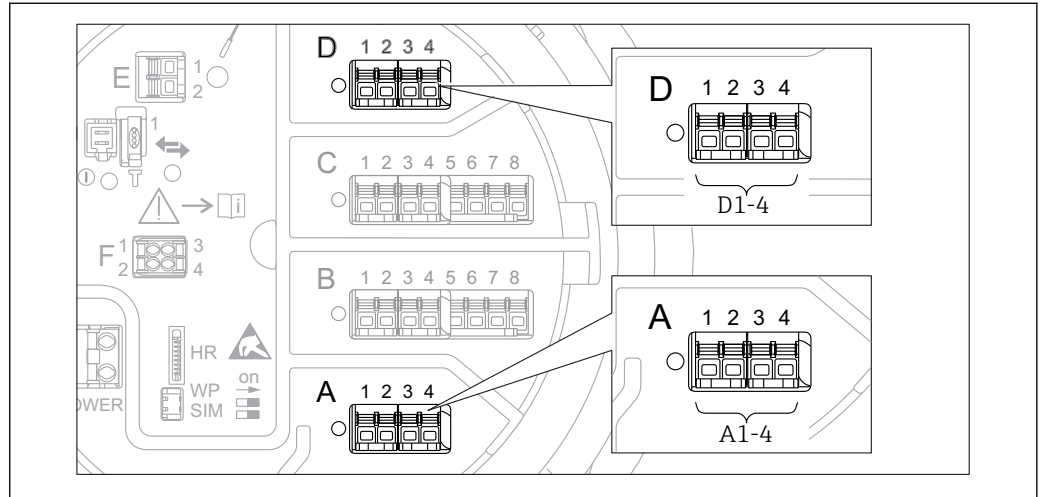

A0031200

48 Designation of the "Modbus" or "V1" modules (examples); depending on the device version these modules may also be in slot B or C.

Navigation Setup → Advanced setup → Communication

*"Modbus X1-4" or "V1 X1-4" submenu*

This submenu is only present for devices with **MODBUS** and/or **V1** communication interface. There is one submenu of this type for each communication interface.

Navigation Setup → Advanced setup → Communication → Modbus X1-4 / V1 X1-4

**Communication interface protocol**

Navigation Setup → Advanced setup → Communication → Modbus X1-4 / V1 X1-4 → Communication interface protocol

Description Shows the type of communication protocol.

**Additional information**

|              |          |
|--------------|----------|
| Read access  | Operator |
| Write access | -        |

*"Configuration" submenu*

This submenu is only present for devices with a **MODBUS** communication interface.

*Navigation*       Setup → Advanced setup → Communication → Modbus X1-4 → Configuration

---

**Baudrate** 

---

**Navigation**       Setup → Advanced setup → Communication → Modbus X1-4 → Configuration → Baudrate

**Prerequisite**      **Communication interface protocol (→  155) = MODBUS**

**Description**      Defines the baud rate of the Modbus communication.

- Selection**
- 300 BAUD
  - 600 BAUD
  - 1200 BAUD
  - 2400 BAUD
  - 4800 BAUD
  - 9600 BAUD
  - 19200 BAUD

**Factory setting**      9600 BAUD

**Additional information**

|              |             |
|--------------|-------------|
| Read access  | Operator    |
| Write access | Maintenance |

---

**Parity** 

---

**Navigation**       Setup → Advanced setup → Communication → Modbus X1-4 → Configuration → Parity

**Prerequisite**      **Communication interface protocol (→  155) = MODBUS**

**Description**      Defines the parity of the Modbus communication.

- Selection**
- Odd
  - Even
  - None / 1 stop bit
  - None / 2 stop bits

**Factory setting**      None / 1 stop bit

**Additional information**

|              |             |
|--------------|-------------|
| Read access  | Operator    |
| Write access | Maintenance |

**Modbus address**



**Navigation** Setup → Advanced setup → Communication → Modbus X1-4 → Configuration → Device ID

**Prerequisite** **Communication interface protocol (→ 155) = MODBUS**

**Description** Defines the Modbus address of the device.

**User entry** 1 to 247

**Factory setting** 1

**Additional information**

|              |             |
|--------------|-------------|
| Read access  | Operator    |
| Write access | Maintenance |

**Float swap mode**



**Navigation** Setup → Advanced setup → Communication → Modbus X1-4 → Configuration → Float swap mode

**Prerequisite** **Communication interface protocol (→ 155) = MODBUS**

**Description** Sets the format of how the floating point value is transferred on Modbus.

- Selection**
- Normal 3-2-1-0
  - Swap 0-1-2-3
  - WW Swap 1-0-3-2

**Factory setting** Swap 0-1-2-3

**Additional information**

|              |             |
|--------------|-------------|
| Read access  | Operator    |
| Write access | Maintenance |

**Bus termination**



**Navigation** Setup → Advanced setup → Communication → Modbus X1-4 → Configuration → Bus termination

**Prerequisite** **Communication interface protocol (→ 155) = MODBUS**

**Description** Activates or deactivates the bus termination at the device. Should only be activated on the last device in a loop.

- Selection**
- Off
  - On

**Factory setting**

Off

**Additional information**

|                     |             |
|---------------------|-------------|
| <b>Read access</b>  | Operator    |
| <b>Write access</b> | Maintenance |

*"Configuration" submenu*

This submenu is only present for devices with a **V1** communication interface.

*Navigation*       Setup → Advanced setup → Communication → V1 X1-4 → Configuration

---

**Communication interface protocol variant** 

**Navigation**       Setup → Advanced setup → Communication → V1 X1-4 → Configuration → Communication interface protocol variant

**Description**      Determines which variant of the V1 protocol is used.

**User interface**

- None
- V1\*

**Factory setting**      None

**Additional information**

|              |             |
|--------------|-------------|
| Read access  | Operator    |
| Write access | Maintenance |

---

**V1 address** 

**Navigation**       Setup → Advanced setup → Communication → V1 X1-4 → Configuration → V1 address

**Prerequisite**      **Communication interface protocol variant (→  159) = V1**

**Description**      Identifier of the device for the V1 communication.

**User entry**      0 to 99

**Factory setting**      1

**Additional information**

|              |             |
|--------------|-------------|
| Read access  | Operator    |
| Write access | Maintenance |

---

\* Visibility depends on order options or device settings

**V1 address**



**Navigation** Setup → Advanced setup → Communication → V1 X1-4 → Configuration → V1 address

**Prerequisite** **Communication interface protocol variant (→ 159)**

**Description** Identifier of the previous device for V1 communication.

**User entry** 0 to 255

**Factory setting** 1

**Additional information**

|              |             |
|--------------|-------------|
| Read access  | Operator    |
| Write access | Maintenance |

**Level mapping**



**Navigation** Setup → Advanced setup → Communication → V1 X1-4 → Configuration → Level mapping

**Prerequisite** **Communication interface protocol (→ 155) = V1**

**Description** Determines the transmittable range of levels.

**Selection**

- +ve
- +ve & -ve

**Factory setting** +ve

**Additional information**

|              |             |
|--------------|-------------|
| Read access  | Operator    |
| Write access | Maintenance |

In V1, the level is always represented by a number in the range from 0 to 999 999. This number corresponds to a level as follows:

*"Level mapping" = "+ve"*

| Number  | Corresponding level |
|---------|---------------------|
| 0       | 0.0 mm              |
| 999 999 | 99 999.9 mm         |

*"Level mapping" = "+ve & -ve"*

| Number  | Corresponding level |
|---------|---------------------|
| 0       | 0.0 mm              |
| 500 000 | 50 000.0 mm         |



| Number  | Corresponding level |
|---------|---------------------|
| 500 001 | -0.1 mm             |
| 999 999 | -49 999.9 mm        |

**Line impedance**



**Navigation** Setup → Advanced setup → Communication → V1 X1-4 → Configuration → Line impedance

**Prerequisite** **Communication interface protocol (→ 155) = V1**

**Description** Adjusts the impedance of the communication line.

**User entry** 0 to 15

**Factory setting** 15

**Additional information**

|              |             |
|--------------|-------------|
| Read access  | Operator    |
| Write access | Maintenance |

The line impedance affects the voltage difference between a logical 0 and a logical 1 on the message of the device to the bus. The default setting is suitable for most applications.

*"V1 input selector" submenu*

This submenu is only present for devices with a **V1** communication interface.

*Navigation*       Setup → Advanced setup → Communication → V1 X1-4 → V1 input selector

---

**Alarm 1 input source** 

---

**Navigation**       Setup → Advanced setup → Communication → V1 X1-4 → V1 input selector → Alarm 1 input source

**Description**      Determines which discrete value will be transmitted as V1 alarm 1 status.

- Selection**
- None
  - Alarm 1-4 any
  - Alarm 1-4 HighHigh
  - Alarm 1-4 High or HighHigh
  - Alarm 1-4 High
  - Alarm 1-4 Low
  - Alarm 1-4 Low or LowLow
  - Alarm 1-4 LowLow

**Factory setting**      None

**Additional information**

|              |             |
|--------------|-------------|
| Read access  | Operator    |
| Write access | Maintenance |

---

**Alarm 2 input source** 

---

**Navigation**       Setup → Advanced setup → Communication → V1 X1-4 → V1 input selector → Alarm 2 input source

**Description**      Determines which discrete value will be transmitted as V1 alarm 2 status.

- Selection**
- None
  - Alarm 1-4 any
  - Alarm 1-4 HighHigh
  - Alarm 1-4 High or HighHigh
  - Alarm 1-4 High
  - Alarm 1-4 Low
  - Alarm 1-4 Low or LowLow
  - Alarm 1-4 LowLow

**Factory setting**      None

**Additional information**

|              |             |
|--------------|-------------|
| Read access  | Operator    |
| Write access | Maintenance |

---

**Value percent selector**
**Navigation**

Setup → Advanced setup → Communication → V1 X1-4 → V1 input selector → Value percent selector

**Description**

Selects which value shall be transmitted as a 0..100% value in the V1 Z0/Z1 message.

**Selection**

- None
- Tank level %
- Tank ullage %
- AIO B1-3 value % \*
- AIO C1-3 value % \*

**Factory setting**

None

**Additional information**

|              |             |
|--------------|-------------|
| Read access  | Operator    |
| Write access | Maintenance |

---

\* Visibility depends on order options or device settings

*"HART output" submenu*

*Navigation*       Setup → Advanced setup → Communication → HART output

*"Configuration" submenu*

*Navigation*       Setup → Advanced setup → Communication → HART output → Configuration

**System polling address** 

**Navigation**       Setup → Advanced setup → Communication → HART output → Configuration → System polling address

**Description**      Device address for HART communication.

**User entry**      0 to 63

**Factory setting**      15

**Additional information**

|                     |             |
|---------------------|-------------|
| <b>Read access</b>  | Operator    |
| <b>Write access</b> | Maintenance |

**No. of preambles** 

**Navigation**       Setup → Advanced setup → Communication → HART output → Configuration → No. of preambles

**Description**      Defines the number of preambles in the HART telegram.

**User entry**      5 to 20

**Factory setting**      5

**Additional information**

|                     |             |
|---------------------|-------------|
| <b>Read access</b>  | Operator    |
| <b>Write access</b> | Maintenance |

**PV source** 

**Navigation**       Setup → Advanced setup → Communication → HART output → Configuration → PV source

**Description**      Decides, if the PV configuration is according to an analog output (HART slave) or customized (in case of HART tunneling only).

- Selection**
- AIO B1-3 \*
  - AIO C1-3 \*
  - Custom

**Factory setting** Custom

**Additional information**

|              |             |
|--------------|-------------|
| Read access  | Maintenance |
| Write access | Maintenance |

---

**Assign PV**



**Navigation** Setup → Advanced setup → Communication → HART output → Configuration → Assign PV

**Prerequisite** PV source (→ 164) = Custom

**Description** Assigns a tank variable to the primary HART variable (PV).

- Selection**
- None
  - Tank level
  - Tank ullage
  - Measured level
  - Distance
  - Displacer position
  - Water level
  - Upper interface level
  - Lower interface level
  - Bottom level
  - Tank reference height
  - Liquid temperature
  - Vapor temperature
  - Air temperature
  - Observed density value
  - Average profile density
  - Upper density
  - Middle density
  - Lower density
  - P1 (bottom)
  - P2 (middle)
  - P3 (top)
  - GP 1 value
  - GP 2 value
  - GP 3 value
  - GP 4 value

**Factory setting** Tank level

---

\* Visibility depends on order options or device settings

**Additional information**

|              |             |
|--------------|-------------|
| Read access  | Operator    |
| Write access | Maintenance |

 The **Measured level** option doesn't contain a unit. If a unit is needed, select the **Tank level** option.

**0 % value**



**Navigation**

 Setup → Advanced setup → Communication → HART output → Configuration → 0 % value

**Prerequisite**

**PV source = Custom**

**Description**

0% value of the primary variable (PV).

**User entry**

-100 000 to 100 000 mm

**Factory setting**

0 mm

**Additional information**

|              |             |
|--------------|-------------|
| Read access  | Operator    |
| Write access | Maintenance |

**100 % value**



**Navigation**

 Setup → Advanced setup → Communication → HART output → Configuration → 100 % value

**Prerequisite**

**PV source = Custom**

**Description**

100% value of the primary variable (PV).

**User entry**

-100 000 to 100 000 mm

**Factory setting**

0 mm

**Additional information**

|              |             |
|--------------|-------------|
| Read access  | Operator    |
| Write access | Maintenance |

**PV mA selector**



**Navigation**

 Setup → Advanced setup → Communication → HART output → Configuration → PV mA selector

**Prerequisite**

**PV source = Custom**

**Description** Assigns a current to the primary HART variable (PV).

**Selection**

- None
- AIO B1-3 value mA \*
- AIO C1-3 value mA \*

**Factory setting** None



**Additional information**

|              |             |
|--------------|-------------|
| Read access  | Operator    |
| Write access | Maintenance |

---

### Primary variable (PV)

---

**Navigation**   Setup → Advanced setup → Communication → HART output → Configuration → Primary variable (PV)

**Description** Shows the value of the primary HART variable (PV).



**Additional information**

|              |          |
|--------------|----------|
| Read access  | Operator |
| Write access | -        |

---

### Percent of range

---

**Navigation**   Setup → Advanced setup → Communication → HART output → Configuration → Percent of range

**Description** Shows the value of the primary variable (PV) as a percentage of the defined 0% to 100% range.

**Additional information**



|              |          |
|--------------|----------|
| Read access  | Operator |
| Write access | -        |

---

### Assign SV

---



**Navigation**   Setup → Advanced setup → Communication → HART output → Configuration → Assign SV

**Description** Assigns a tank variable to the secondary HART variable (SV).

**Selection**

- None
- Tank level
- Tank ullage

---

\* Visibility depends on order options or device settings

- Measured level
- Distance
- Displacer position
- Water level
- Upper interface level
- Lower interface level
- Bottom level
- Tank reference height
- Liquid temperature
- Vapor temperature
- Air temperature
- Observed density value
- Average profile density
- Upper density
- Middle density
- Lower density
- P1 (bottom)
- P2 (middle)
- P3 (top)
- GP 1 value
- GP 2 value
- GP 3 value
- GP 4 value

**Factory setting**

Liquid temperature

**Additional information**

|              |             |
|--------------|-------------|
| Read access  | Operator    |
| Write access | Maintenance |

 The **Measured level** option doesn't contain a unit. If a unit is needed, select the **Tank level** option.

---

**Secondary variable (SV)**

---

**Navigation**

 Setup → Advanced setup → Communication → HART output → Configuration → Secondary variable (SV)

**Prerequisite**

**Assign SV (→  167) ≠ None**

**Description**

Shows the value of the secondary HART variable (SV).

**Additional information**

|              |          |
|--------------|----------|
| Read access  | Operator |
| Write access | -        |



---

**Assign TV**
**Navigation**

Setup → Advanced setup → Communication → HART output → Configuration  
→ Assign TV

**Description**

Assigns a tank variable to the third HART variable (TV).

**Selection**

- None
- Tank level
- Tank ullage
- Measured level
- Distance
- Displacer position
- Water level
- Upper interface level
- Lower interface level
- Bottom level
- Tank reference height
- Liquid temperature
- Vapor temperature
- Air temperature
- Observed density value
- Average profile density
- Upper density
- Middle density
- Lower density
- P1 (bottom)
- P2 (middle)
- P3 (top)
- GP 1 value
- GP 2 value
- GP 3 value
- GP 4 value

**Factory setting**

Water level

**Additional information**

|              |             |
|--------------|-------------|
| Read access  | Operator    |
| Write access | Maintenance |



The **Measured level** option doesn't contain a unit. If a unit is needed, select the **Tank level** option.

---

**Tertiary variable (TV)**
**Navigation**

Setup → Advanced setup → Communication → HART output → Configuration  
→ Tertiary variable (TV)

**Prerequisite**

**Assign TV** (→ 169) ≠ None

**Description**

Shows the value of the third HART variable (TV).

**Additional information**

|              |          |
|--------------|----------|
| Read access  | Operator |
| Write access | -        |

**Assign QV****Navigation**

Setup → Advanced setup → Communication → HART output → Configuration  
→ Assign QV

**Description**

Assigns a tank variable to the fourth HART variable (QV).

**Selection**

- None
- Tank level
- Tank ullage
- Measured level
- Distance
- Displacer position
- Water level
- Upper interface level
- Lower interface level
- Bottom level
- Tank reference height
- Liquid temperature
- Vapor temperature
- Air temperature
- Observed density value
- Average profile density
- Upper density
- Middle density
- Lower density
- P1 (bottom)
- P2 (middle)
- P3 (top)
- GP 1 value
- GP 2 value
- GP 3 value
- GP 4 value

**Factory setting**

Observed density value

**Additional information**

|              |             |
|--------------|-------------|
| Read access  | Operator    |
| Write access | Maintenance |

The **Measured level** option doesn't contain a unit. If a unit is needed, select the **Tank level** option.

---

**Quaternary variable (QV)**

---

**Navigation**

  Setup → Advanced setup → Communication → HART output → Configuration  
→ Quaternary variable (QV)

**Prerequisite**

**Assign QV (→  170) ≠ None**

**Description**

Shows the value of the fourth HART variable (QV).

**Additional information**

|              |          |
|--------------|----------|
| Read access  | Operator |
| Write access | -        |

*"Information" submenu*

Navigation  Setup → Advanced setup → Communication → HART output → Information

**HART short tag** 

**Navigation**  Setup → Advanced setup → Communication → HART output → Information → HART short tag

**Description** Defines the short tag for the measuring point. Maximum length: 8 characters Allowed characters: A-Z, 0-9, certain special characters.

**Factory setting** NMR8x

**Additional information**

|              |             |
|--------------|-------------|
| Read access  | Operator    |
| Write access | Maintenance |

**Device tag** 

**Navigation**  Setup → Advanced setup → Communication → HART output → Information → Device tag

**Description** Enter a unique name for the measuring point to identify the device quickly within the plant.

**Factory setting** NMR8x

**Additional information**

|              |             |
|--------------|-------------|
| Read access  | Operator    |
| Write access | Maintenance |

**HART descriptor** 

**Navigation**  Setup → Advanced setup → Communication → HART output → Information → HART descriptor

**Description** User defined HART descriptor (16 characters).

**Factory setting** NMR8x

**Additional information**

|              |             |
|--------------|-------------|
| Read access  | Operator    |
| Write access | Maintenance |

**HART message**



**Navigation**      Setup → Advanced setup → Communication → HART output → Information → HART message

**Description**      User defined HART message (32 characters).

**Factory setting**      NMR8x

**Additional information**

|                     |             |
|---------------------|-------------|
| <b>Read access</b>  | Operator    |
| <b>Write access</b> | Maintenance |

**HART date code**



**Navigation**      Setup → Advanced setup → Communication → HART output → Information → HART date code

**Description**      Enter date of the last configuration change. Use this format yyyy-mm-dd.

**Factory setting**      2009-07-20

**Additional information**

|                     |             |
|---------------------|-------------|
| <b>Read access</b>  | Operator    |
| <b>Write access</b> | Maintenance |

**"Application" submenu**

Navigation  Setup → Advanced setup → Application

*"Tank configuration" submenu*

Navigation  Setup → Advanced setup → Application → Tank configuration

*"Level" submenu*

Navigation  Setup → Advanced setup → Application → Tank configuration → Level

---

**Empty** 

---

**Navigation**  Setup → Advanced setup → Application → Tank configuration → Level → Empty

**Description** Distance from reference point to zero position (tank bottom or datum plate).

**User entry** 0 to 10 000.00 mm

**Factory setting** Dependent on the device version

**Additional information**

|              |             |
|--------------|-------------|
| Read access  | Operator    |
| Write access | Maintenance |

 The reference point is the lower edge of the device flange.

---

**Tank reference height** 

---

**Navigation**  Setup → Advanced setup → Application → Tank configuration → Level → Tank reference height

**Description** Defines the distance from the dipping reference point to the zero position (tank bottom or datum plate).

**User entry** 0 to 10 000.00 mm

**Factory setting** Dependent on the device version

**Additional information**

|              |             |
|--------------|-------------|
| Read access  | Operator    |
| Write access | Maintenance |

**Tank level**

**Navigation**  Setup → Advanced setup → Application → Tank configuration → Level → Tank level

**Description** Shows the distance from the zero position (tank bottom or datum plate) to the product surface.

**Additional information**

|              |          |
|--------------|----------|
| Read access  | Operator |
| Write access | -        |

**Set level**



**Navigation**  Setup → Advanced setup → Application → Tank configuration → Level → Set level

**Description** If the level measured by the device does not match the actual level obtained by a manual dip, enter the correct level into this parameter.

**User entry** 0 to 10 000.00 mm

**Factory setting** 0 mm



**Additional information**

|              |             |
|--------------|-------------|
| Read access  | Operator    |
| Write access | Maintenance |

The device adjusts the **Empty** parameter (→  121) according to the entered value, such that the measured level will match the actual level.

**Water level source**



**Navigation**   Setup → Advanced setup → Application → Tank configuration → Level → Water level source

**Description** Defines the source of the bottom water level.

- Selection**
- Manual value
  - Bottom level
  - HART device 1 ... 15 level
  - AIO B1-3 value
  - AIO C1-3 value
  - AIP B4-8 value
  - AIP C4-8 value

**Factory setting** Manual value

**Additional information**

|              |             |
|--------------|-------------|
| Read access  | Operator    |
| Write access | Maintenance |

**Manual water level** 

**Navigation**   Setup → Advanced setup → Application → Tank configuration → Level → Manual water level

**Prerequisite** **Water level source (→  175) = Manual value**

**Description** Defines the manual value of the bottom water level.



**User entry** -2 000 to 5 000 mm

**Factory setting** 0 mm

**Additional information**

|              |             |
|--------------|-------------|
| Read access  | Operator    |
| Write access | Maintenance |

**Water level**

**Navigation**   Setup → Advanced setup → Application → Tank configuration → Level → Water level

**Description** Shows the bottom water level.

**Additional information**

|              |          |
|--------------|----------|
| Read access  | Operator |
| Write access | -        |

**Blocking distance** 

**Navigation**   Setup → Advanced setup → Application → Tank configuration → Level → Blocking distance

**Description** No echos are evaluated within the blocking distance BD. Therefore, BD can be used to suppress interference echos in the vicinity of the antenna.

**User entry** Positive floating-point number

**Factory setting** 800 mm

**Additional information**

|              |             |
|--------------|-------------|
| Read access  | Operator    |
| Write access | Maintenance |



*"Temperature" submenu*

|             |             |
|-------------|-------------|
| Read access | Maintenance |
|-------------|-------------|

Navigation  Setup → Advanced setup → Application → Tank configuration → Temperature

**Liquid temp source** 

**Navigation**  Setup → Advanced setup → Application → Tank configuration → Temperature → Liquid temp source

**Description** Defines source from which the liquid temperature is obtained.

- Selection**
- Manual value
  - HART device 1 ... 15 temperature
  - AIO B1-3 value
  - AIO C1-3 value
  - AIP B4-8 value
  - AIP C4-8 value

**Factory setting** Manual value

**Additional information**

|              |             |
|--------------|-------------|
| Read access  | Operator    |
| Write access | Maintenance |

**Manual liquid temperature** 

**Navigation**  Setup → Advanced setup → Application → Tank configuration → Temperature → Manual liquid temperature

**Prerequisite** **Liquid temp source (→  125) = Manual value**

**Description** Defines the manual value of the liquid temperature.

**User entry** -50 to 300 °C

**Factory setting** 25 °C

**Additional information**

|              |             |
|--------------|-------------|
| Read access  | Operator    |
| Write access | Maintenance |

---

**Liquid temperature**

---

**Navigation**  Setup → Advanced setup → Application → Tank configuration → Temperature → Liquid temperature

**Description** Shows the average or spot temperature of the measured liquid.

**Additional information**

|              |          |
|--------------|----------|
| Read access  | Operator |
| Write access | -        |

---

**Air temperature source**

---



**Navigation**  Setup → Advanced setup → Application → Tank configuration → Temperature → Air temperature source

**Description** Defines source from which the air temperature is obtained.

**Selection**

- Manual value
- HART device 1 ... 15 temperature
- AIO B1-3 value
- AIO C1-3 value
- AIP B4-8 value
- AIP C4-8 value

**Factory setting**

Manual value

**Additional information**

|              |             |
|--------------|-------------|
| Read access  | Operator    |
| Write access | Maintenance |

---

**Manual air temperature**

---



**Navigation**  Setup → Advanced setup → Application → Tank configuration → Temperature → Manual air temperature

**Prerequisite** **Air temperature source** (→  178) = **Manual value**

**Description** Defines the manual value of the air temperature.

**User entry** -50 to 300 °C

**Factory setting** 25 °C

**Additional information**

|              |             |
|--------------|-------------|
| Read access  | Operator    |
| Write access | Maintenance |

**Air temperature**

**Navigation**  Setup → Advanced setup → Application → Tank configuration → Temperature → Air temperature

**Description** Shows the air temperature.

**Additional information**

|              |          |
|--------------|----------|
| Read access  | Operator |
| Write access | -        |

**Vapor temp source**



**Navigation**  Setup → Advanced setup → Application → Tank configuration → Temperature → Vapor temp source

**Description** Defines the source from which the vapor temperature is obtained.

- Selection**
- Manual value
  - HART device 1 ... 15 vapor temp
  - AIO B1-3 value
  - AIO C1-3 value
  - AIP B4-8 value
  - AIP C4-8 value

**Factory setting** Manual value

**Additional information**

|              |             |
|--------------|-------------|
| Read access  | Operator    |
| Write access | Maintenance |

**Manual vapor temperature**



**Navigation**  Setup → Advanced setup → Application → Tank configuration → Temperature → Manual vapor temperature

**Prerequisite** **Vapor temp source (→  179) = Manual value**

**Description** Defines the manual value of the vapor temperature.

**User entry** -50 to 300 °C

**Factory setting** 25 °C

**Additional information**

|              |             |
|--------------|-------------|
| Read access  | Operator    |
| Write access | Maintenance |

---

**Vapor temperature**

---

**Navigation**

 Setup → Advanced setup → Application → Tank configuration → Temperature  
→ Vapor temperature

**Description**

Shows the measured vapor temperature.

**Additional information**

|              |          |
|--------------|----------|
| Read access  | Operator |
| Write access | -        |

*"Density" submenu*

*Navigation*       Setup → Advanced setup → Application → Tank configuration → Density

**Observed density source** 

**Navigation**       Setup → Advanced setup → Application → Tank configuration → Density → Observed density source

**Description**      Determines how the density is obtained.

- Selection**
- HTG \*
  - HTMS \*
  - Average profile density \*
  - Upper density
  - Middle density
  - Lower density

**Factory setting**      Dependent on the device version

**Additional information**

|              |             |
|--------------|-------------|
| Read access  | Operator    |
| Write access | Maintenance |

**Observed density**

**Navigation**       Setup → Advanced setup → Application → Tank configuration → Density → Observed density

**Description**      Shows the measured or calculated density.

**Additional information**

|              |          |
|--------------|----------|
| Read access  | Operator |
| Write access | -        |

**Air density** 

**Navigation**       Setup → Advanced setup → Application → Tank configuration → Density → Air density

**Description**      Defines the density of the air surrounding the tank.

**User entry**      0.0 to 500.0 kg/m<sup>3</sup>

\* Visibility depends on order options or device settings

**Factory setting** 1.2 kg/m<sup>3</sup>

**Additional information**

|              |             |
|--------------|-------------|
| Read access  | Operator    |
| Write access | Maintenance |

---

**Vapor density**



**Navigation**

Setup → Advanced setup → Application → Tank configuration → Density → Vapor density

**Description**

Defines the density of the gas phase in the tank.

**User entry**

0.0 to 500.0 kg/m<sup>3</sup>

**Factory setting**

1.2 kg/m<sup>3</sup>

**Additional information**

|              |             |
|--------------|-------------|
| Read access  | Operator    |
| Write access | Maintenance |

*"Pressure" submenu*

Navigation  Setup → Advanced setup → Application → Tank configuration → Pressure

**P1 (bottom) source** 

**Navigation**  Setup → Advanced setup → Application → Tank configuration → Pressure → P1 (bottom) source

**Description** Defines the source of the bottom pressure (P1).

- Selection**
- Manual value
  - HART device 1 ... 15 pressure
  - AIO B1-3 value
  - AIO C1-3 value
  - AIP B4-8 value
  - AIP C4-8 value

**Factory setting** Manual value

**Additional information**

|              |             |
|--------------|-------------|
| Read access  | Operator    |
| Write access | Maintenance |

**P1 (bottom)**

**Navigation**  Setup → Advanced setup → Application → Tank configuration → Pressure → P1 (bottom)

**Description** Shows the pressure at the tank bottom.

**Additional information**

|              |          |
|--------------|----------|
| Read access  | Operator |
| Write access | -        |

**P1 (bottom) manual pressure** 

**Navigation**  Setup → Advanced setup → Application → Tank configuration → Pressure → P1 (bottom) manual pressure

**Prerequisite** P1 (bottom) source (→  183) = Manual value

**Description** Defines the manual value of the bottom pressure (P1).

**User entry** -25 to 25 bar

**Factory setting** 0 bar



**Additional information**

|              |             |
|--------------|-------------|
| Read access  | Operator    |
| Write access | Maintenance |

---

**P1 position** 

---

**Navigation**   Setup → Advanced setup → Application → Tank configuration → Pressure → P1 position

**Description** Defines the position of the bottom pressure transmitter (P1), measured from zero position (tank bottom or datum plate).

**User entry** -10 000 to 100 000 mm

**Factory setting** 5 000 mm



**Additional information**

|              |             |
|--------------|-------------|
| Read access  | Operator    |
| Write access | Maintenance |

---

**P1 offset** 

---

**Navigation**   Setup → Advanced setup → Application → Tank configuration → Pressure → P1 offset

**Description** Offset for the bottom pressure (P1). The offset is added to the measured pressure prior to any tank calculation.

**User entry** -25 to 25 bar

**Factory setting** 0 bar



**Additional information**

|              |             |
|--------------|-------------|
| Read access  | Operator    |
| Write access | Maintenance |

---

**P1 absolute / gauge** 

---

**Navigation**   Setup → Advanced setup → Application → Tank configuration → Pressure → P1 absolute / gauge

**Description** Defines whether the connected pressure transmitter measures an absolute or a gauge pressure.

**Selection**

- Absolute
- Gauge



**Factory setting**

Gauge

**Additional information**

|              |             |
|--------------|-------------|
| Read access  | Operator    |
| Write access | Maintenance |

**P3 (top) source**



**Navigation**

Setup → Advanced setup → Application → Tank configuration → Pressure → P3 (top) source

**Description**

Defines the source of the top pressure (P3).

**Selection**

- Manual value
- HART device 1 ... 15 pressure
- AIO B1-3 value
- AIO C1-3 value
- AIP B4-8 value
- AIP C4-8 value

**Factory setting**

Manual value

**Additional information**

|              |             |
|--------------|-------------|
| Read access  | Operator    |
| Write access | Maintenance |

**P3 (top)**

**Navigation**

Setup → Advanced setup → Application → Tank configuration → Pressure → P3 (top)

**Description**

Shows the pressure (P3) at the top transmitter.

**Additional information**

|              |          |
|--------------|----------|
| Read access  | Operator |
| Write access | -        |

**P3 (top) manual pressure**



**Navigation**

Setup → Advanced setup → Application → Tank configuration → Pressure → P3 (top) manual pressure

**Prerequisite**

**P3 (top) source** (→ 185) = **Manual value**

**Description**

Defines the manual value of the top pressure (P3).

**User entry**

-2.5 to 2.5 bar

**Factory setting**

0 bar

**Additional information**

|              |             |
|--------------|-------------|
| Read access  | Operator    |
| Write access | Maintenance |

**P3 position****Navigation**

Setup → Advanced setup → Application → Tank configuration → Pressure → P3 position

**Description**

Defines the position of the top pressure transmitter (P3), measured from zero position (tank bottom or datum plate).

**User entry**

0 to 100 000 mm

**Factory setting**

20 000 mm

**Additional information**

|              |             |
|--------------|-------------|
| Read access  | Operator    |
| Write access | Maintenance |

**P3 offset****Navigation**

Setup → Advanced setup → Application → Tank configuration → Pressure → P3 offset

**Description**

Offset for the top pressure (P3). The offset is added to the measured pressure prior to any tank calculation.

**User entry**

-2.5 to 2.5 bar

**Factory setting**

0 bar

**Additional information**

|              |             |
|--------------|-------------|
| Read access  | Operator    |
| Write access | Maintenance |

**P3 absolute / gauge****Navigation**

Setup → Advanced setup → Application → Tank configuration → Pressure → P3 absolute / gauge

**Description**

Defines whether the connected pressure transmitter measures an absolute or a gauge pressure.

**Selection**

- Absolute
- Gauge

**Factory setting**

Gauge

**Additional information**

|                     |             |
|---------------------|-------------|
| <b>Read access</b>  | Operator    |
| <b>Write access</b> | Maintenance |

**Ambient pressure****Navigation**

Setup → Advanced setup → Application → Tank configuration → Pressure  
→ Ambient pressure

**Description**

Defines the manual value of the ambient pressure.

**User entry**

0 to 2.5 bar

**Factory setting**

1 bar

**Additional information**

|                     |             |
|---------------------|-------------|
| <b>Read access</b>  | Operator    |
| <b>Write access</b> | Maintenance |

*"Tank calculation" submenu*

Navigation  Setup → Advanced setup → Application → Tank calculation

*"HyTD" submenu**Overview*

Hydrostatic Tank Deformation can be used to compensate the vertical movement of the Gauge Reference Height (GRH) due to bulging of the tank shell caused by the hydrostatic pressure exerted by the liquid stored in the tank. The compensation is based on a linear approximation obtained from manual hand dips at several levels distributed over the full range of the tank.

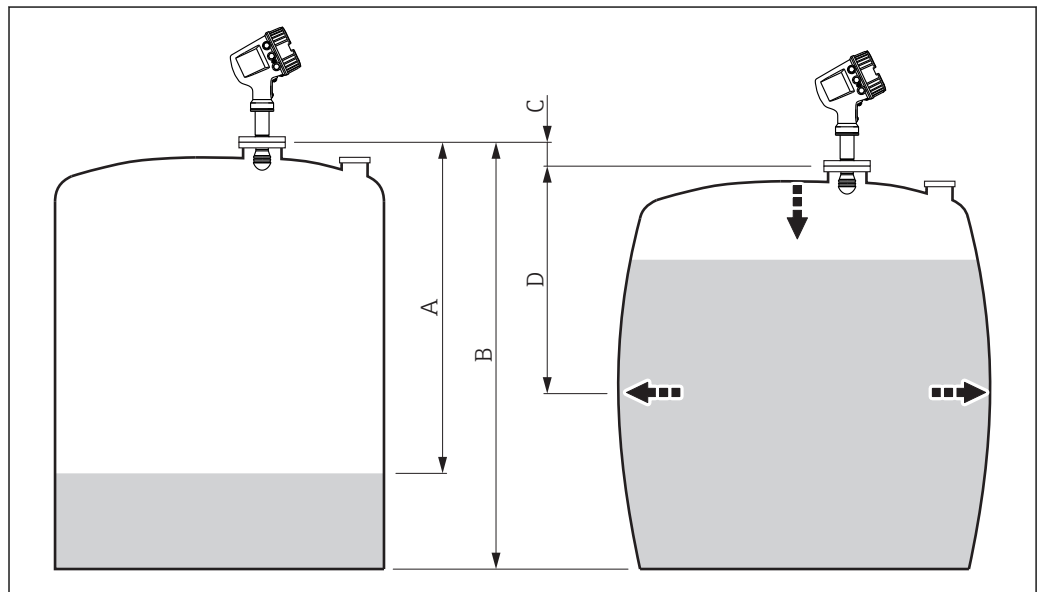

 49 Correction of the hydrostatic tank deformation (HyTD)

A "Distance" (level below  $L_0$  → "HyTD correction value" = 0)

B Gauge Reference Height (GRH)

C HyTD correction value

D "Distance" (level above  $L_0$  → "HyTD correction value" > 0)

*Linear approximation of the HyTD correction*

The real amount of deformation varies non-linearly with the level due to the construction of the tank. However, as the correction values are typically small compared to the measured level, a simple straight line method can be used with good results.

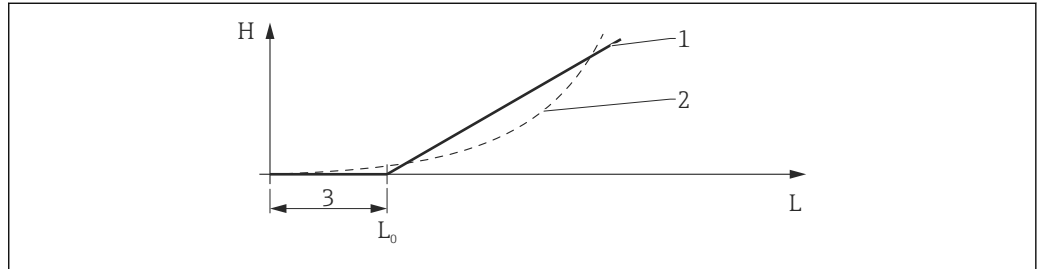

A0028724

50 Calculation of the HyTD correction

- 1 Linear correction according to "Deformation factor (→ 191)"
- 2 Real correction
- 3 Starting level (→ 190)
- L Measured level
- H HyTD correction value (→ 190)

*Calculation of the HyTD correction*

$$L \leq L_0 \Rightarrow C_{HyTD} = 0$$

$$L > L_0 \Rightarrow C_{HyTD} = - (L - L_0) \times D$$

A0028715

|                         |                       |
|-------------------------|-----------------------|
| <b>L</b>                | Measured level        |
| <b>L<sub>0</sub></b>    | Starting level        |
| <b>C<sub>HyTD</sub></b> | HyTD correction value |
| <b>D</b>                | Deformation factor    |

*Description of parameters*

**Navigation**  Setup → Advanced setup → Application → Tank calculation → HyTD

**HyTD correction value**

**Navigation**  Setup → Advanced setup → Application → Tank calculation → HyTD → HyTD correction value

**Description** Shows the correction value from the Hydrostatic Tank Deformation.

**Additional information**

|              |          |
|--------------|----------|
| Read access  | Operator |
| Write access | -        |

**HyTD mode** 

**Navigation**  Setup → Advanced setup → Application → Tank calculation → HyTD → HyTD mode

**Description** Activates or deactivates the calculation of the Hydrostatic Tank Deformation.

**Selection**

- No
- Yes

**Factory setting** No

**Additional information**

|              |             |
|--------------|-------------|
| Read access  | Operator    |
| Write access | Maintenance |

**Starting level** 

**Navigation**  Setup → Advanced setup → Application → Tank calculation → HyTD → Starting level

**Description** Defines the starting level for the Hydrostatic Tank Deformation. Levels below this value are not corrected.

**User entry** 0 to 5 000 mm

**Factory setting** 500 mm

**Additional information**

|              |             |
|--------------|-------------|
| Read access  | Operator    |
| Write access | Maintenance |

**Deformation factor**



**Navigation**

Setup → Advanced setup → Application → Tank calculation → HyTD → Deformation factor

**Description**

Defines the deformation factor for the HyTD (change of device position per change of level).

**User entry**

-1.0 to 1.0 %

**Factory setting**



0.2 %

**Additional information**

|                     |             |
|---------------------|-------------|
| <b>Read access</b>  | Operator    |
| <b>Write access</b> | Maintenance |

*"CTSh" submenu**Overview*

CTSh (correction for the thermal expansion of the tank shell) compensates for effects on the Gauge Reference Height (GRH) and on the expansion or contraction of the measuring wire due to temperature effects on the tank shell or stilling well. The temperature effects are separated into two parts, respectively affecting the 'dry' and 'wetted' part of the tank shell or stilling well. The correction function is based on thermal expansion coefficients of steel and insulation factors for both the 'dry' and 'wet' parts of the wire and the tank shell. The temperatures used for the correction can be selected from on manual or measured values.

-  This correction is recommended for the following situations:
  - if the operating temperature deviates considerably from the temperature during calibration ( $\Delta T > 10\text{ °C}$  (18 °F))
  - for extremely high tanks
  - for refrigerated, cryogenic or heated applications
-  As the use of this correction will influence the innage level reading, it is recommended to ensure the manual hand dip and level verification procedures are being conducted correctly before enabling this correction method.
-  This mode cannot be used in conjunction with HTG because the level is not measured relative to the gauge reference height with HTG.



*CTSh: Calculation of the wall temperature*

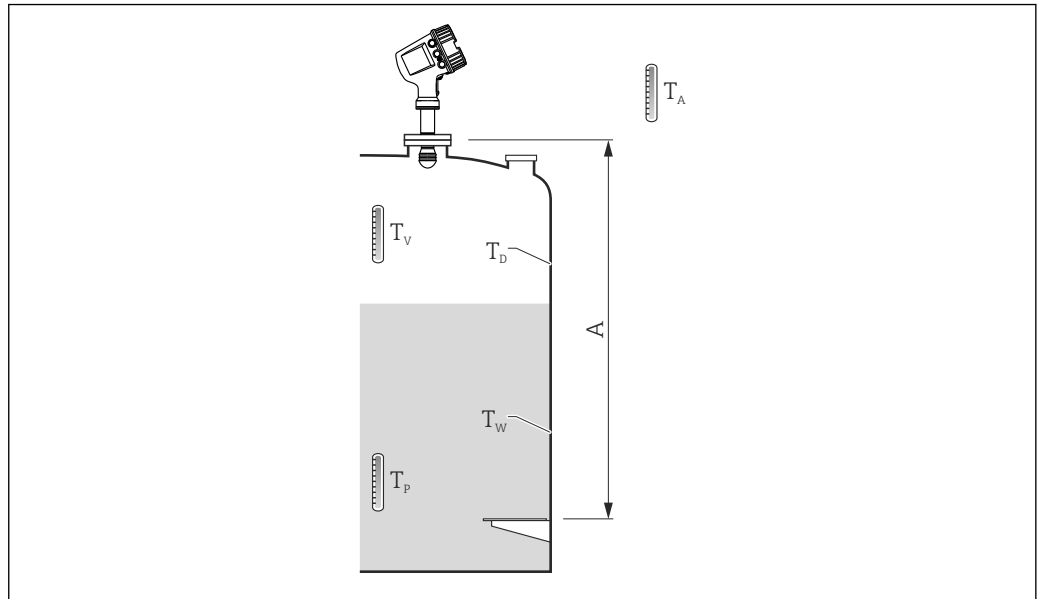

A0028712

51 Parameters for the CTSh calculation

A Gauge Reference Height (GRH)

|       |   |
|-------|---|
| $T_W$ | Temperature of the wetted part of the tank shell      |
| $T_D$ | Temperature of the dry part of the tank shell         |
| $T_P$ | Product temperature                                   |
| $T_V$ | Vapor temperature (in the tank)                       |
| $T_A$ | Ambient temperature (atmosphere surrounding the tank) |

*CTSh: Calculation of the wall temperature*

Depending on the parameters **Covered tank** (→ 195) and **Stilling well** (→ 196), the temperatures  $T_W$  of the wetted and  $T_D$  of the dry part of the tank wall are calculated as follows:

| Covered tank (→ 195) | Stilling well (→ 196) | $T_W$                   | $T_D$                   |
|----------------------|-----------------------|-------------------------|-------------------------|
| Covered              | Yes <sup>1)</sup>     | $T_P$                   | $T_V$                   |
|                      | No                    | $(7/8) T_P + (1/8) T_A$ | $(1/2) T_V + (1/2) T_A$ |
| Open top             | Yes                   | $T_P$                   | $T_A$                   |
|                      | No                    | $(7/8) T_P + (1/8) T_A$ | $T_A$                   |

1) This option is also valid for insulated tanks without a stilling well. This is due to the temperature inside and outside of the tank shell being the same due to the insulation of the tank.

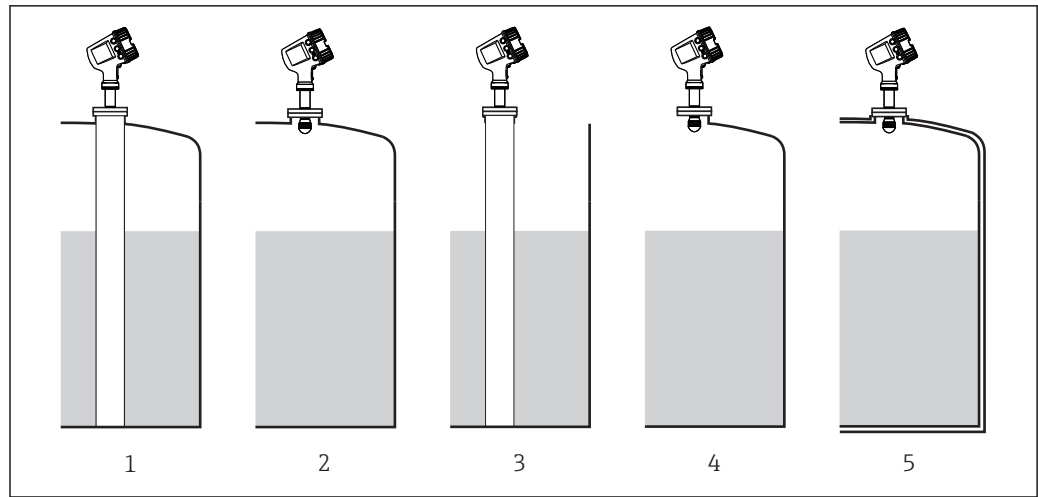

A0030382

- 1 Covered tank (→ 195) = Covered; Stilling well (→ 196) = Yes
- 2 Covered tank (→ 195) = Covered; Stilling well (→ 196) = No
- 3 Covered tank (→ 195) = Open top; Stilling well (→ 196) = Yes
- 4 Covered tank (→ 195) = Open top; Stilling well (→ 196) = No
- 5 Insulated tank: Covered tank (→ 195) = Open top; Stilling well (→ 196) = Yes

*CTSh: Calculation of the correction*

$$C_{CTSh} = \alpha (H - L)(T_D - T_{cal}) + \alpha L (T_W - T_{cal})$$

A0028716

|                         |  |
|-------------------------|--|
| <b>H</b>                | Gauge Reference Height   |
| <b>L</b>                | Measured level   |
| <b>T<sub>D</sub></b>    | Temperature of the dry part of the tank shell (calculated from T <sub>p</sub> , T <sub>v</sub> and T <sub>A</sub> )    |
| <b>T<sub>W</sub></b>    | Temperature of the wetted part of the tank shell (calculated from T <sub>p</sub> , T <sub>v</sub> and T <sub>A</sub> ) |
| <b>T<sub>cal</sub></b>  | Temperature at which the measurement has been calibrated   |
| <b>α</b>                | Linear expansion coefficient   |
| <b>c<sub>CTSh</sub></b> | CTSh correction value  |

*Description of parameters*

**Navigation**       Setup → Advanced setup → Application → Tank calculation → CTSh

**CTSh correction value**

**Navigation**       Setup → Advanced setup → Application → Tank calculation → CTSh → CTSh correction value

**Description**      Shows the CTSh correction value.

**Additional information**

|              |          |
|--------------|----------|
| Read access  | Operator |
| Write access | -        |

**CTSh mode**



**Navigation**       Setup → Advanced setup → Application → Tank calculation → CTSh → CTSh mode

**Description**      Activates or deactivates the CTSh.

- Selection**
- No
  - Yes
  - With wire \*
  - Only wire \*

**Factory setting**      No

**Additional information**

|              |             |
|--------------|-------------|
| Read access  | Operator    |
| Write access | Maintenance |

**Covered tank**



**Navigation**       Setup → Advanced setup → Application → Tank calculation → CTSh → Covered tank

**Description**      Determines whether the tank is covered.

- Selection**
- Open top
  - Covered

**Factory setting**      Open top

\* Visibility depends on order options or device settings

**Additional information**

|              |             |
|--------------|-------------|
| Read access  | Operator    |
| Write access | Maintenance |

 The **Covered** option is only valid for fixed tank roofs. For a floating roof select **Open top**.

**Stilling well****Navigation**

 Setup → Advanced setup → Application → Tank calculation → CTSh → Stilling well

**Description**

Determines whether the device is mounted on a stilling well.

**Selection**

- No
- Yes

**Factory setting**

No

**Additional information**

|              |             |
|--------------|-------------|
| Read access  | Operator    |
| Write access | Maintenance |

**Calibration temperature****Navigation**

 Setup → Advanced setup → Application → Tank calculation → CTSh → Calibration temperature

**Description**

Specify temperature at which the measurement has been calibrated.

**User entry**

-50 to 250 °C

**Factory setting**

25 °C

**Additional information**

|              |             |
|--------------|-------------|
| Read access  | Operator    |
| Write access | Maintenance |

**Linear expansion coefficient****Navigation**

 Setup → Advanced setup → Application → Tank calculation → CTSh → Linear expansion coefficient

**Description**

Defines the linear expansion coefficient of the tank shell material.

**User entry**

0 to 100 ppm

**Factory setting**

15 ppm

**Additional information**

|              |             |
|--------------|-------------|
| Read access  | Operator    |
| Write access | Maintenance |

**Wire expansion coefficient****Navigation**

Setup → Advanced setup → Application → Tank calculation → CTSh → Wire expansion coefficient

**Description**

Defines the expansion coefficient of the wire material of the drum. Value is programmed in factory.

**User entry**

0 to 100 ppm

**Factory setting**

15 ppm

"HTMS" submenu

Overview

The Hybrid Tank Measurement System (HTMS) is a method to calculate the density of a product in a tank based on both a (top mounted) level and at least one (bottom mounted) pressure measurement. An additional pressure sensor can be installed at the top of the tank to provide information about the vapor pressure and to make the density calculation more accurate. The calculation method also takes into account a possible level of water at the bottom of the tank to make density calculations as accurate as possible.

HTMS parameters

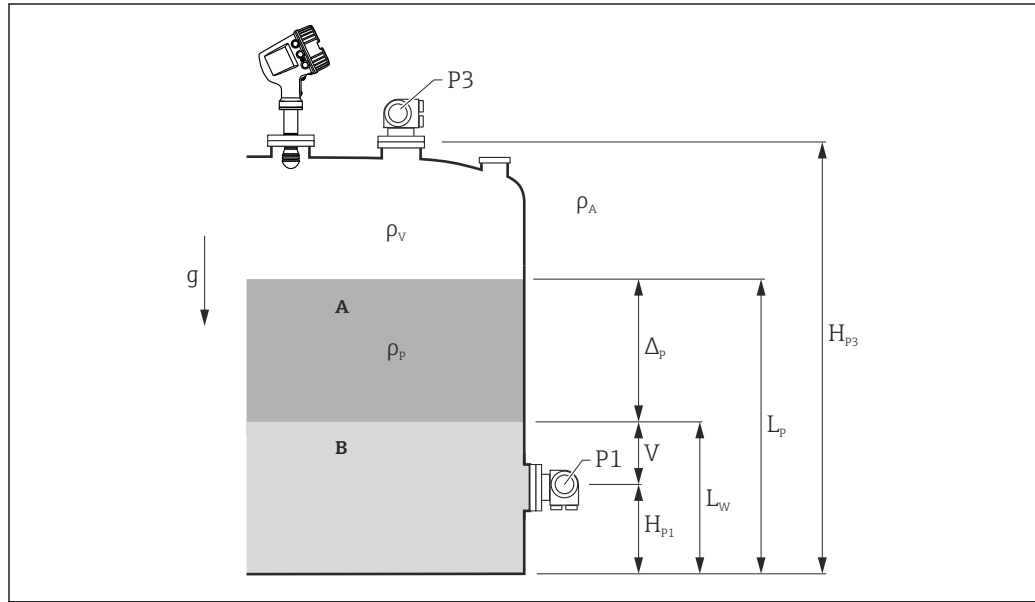

52 HTMS parameters

- A Product
- B Water

| Parameter   | Navigation path   |
|---|---|
| P1 (Bottom pressure)  | Setup → Advanced setup → Tank configuration → Pressure → P1 (bottom)  |
| H <sub>P1</sub> (Position of P1 transmitter)  | Setup → Advanced setup → Tank configuration → Pressure → P1 position  |
| P3 (Top pressure)   | Setup → Advanced setup → Tank configuration → Pressure → P3 (top)   |
| H <sub>P3</sub> (Position of P3 transmitter)  | Setup → Advanced setup → Tank configuration → Pressure → P3 position  |
| ρ <sub>p</sub> (Density of the product <sup>1)</sup> )                                  | <ul style="list-style-type: none"> <li>■ Measured value: Setup → Advanced setup → Calculation → HTMS → Density value</li> <li>■ User-defined value: Setup → Advanced setup → Calculation → HTMS → Manual upper density</li> </ul> |
| ρ <sub>v</sub> (Vapor density)  | Expert → Application → Tank configuration → Density → Vapor density   |
| ρ <sub>A</sub> (Ambient air temperature)  | Setup → Advanced setup → Tank configuration → Density → Air density   |
| g (Local gravity)   | Expert → Application → Tank Calculation → Local gravity   |
| L <sub>p</sub> (Level of the product)   | Operation → Tank level  |
| L <sub>w</sub> (Bottom water level)   | Operation → Water level   |
| V = L <sub>w</sub> - H <sub>P1</sub>  |   |
| Δ <sub>p</sub> = L <sub>p</sub> - L <sub>w</sub> = L <sub>p</sub> - V - H <sub>P1</sub> |   |

1) Depending on the situation this parameter is measured or a user-defined value is used.

*HTMS modes*

Two HTMS modes can be selected in the **HTMS mode** parameter (→  200). The mode determines whether one or two pressure values are used. Depending on the selected mode a number of additional parameters are required for the calculation of the product density.

 The **HTMS P1+P3** option must be used in pressurized tanks in order to compensate for the pressure of the vapor phase.

| HTMS mode<br>(→  200) | Measured variables  | Required additional parameters  | Calculated variables   |
|--|---|---|--|
| HTMS P1  | <ul style="list-style-type: none"> <li>▪ P<sub>1</sub></li> <li>▪ L<sub>p</sub></li> </ul>                          | <ul style="list-style-type: none"> <li>▪ g</li> <li>▪ H<sub>p1</sub></li> <li>▪ L<sub>w</sub> (optional)</li> </ul>   | ρ <sub>p</sub>   |
| HTMS P1+P3   | <ul style="list-style-type: none"> <li>▪ P<sub>1</sub></li> <li>▪ P<sub>3</sub></li> <li>▪ L<sub>p</sub></li> </ul> | <ul style="list-style-type: none"> <li>▪ ρ<sub>v</sub></li> <li>▪ ρ<sub>A</sub></li> <li>▪ g</li> <li>▪ H<sub>p1</sub></li> <li>▪ H<sub>p3</sub></li> <li>▪ L<sub>w</sub> (optional)</li> </ul> | ρ <sub>p</sub><br>(more precise calculation for pressurized tanks) |

*Minimum level*

The density of the product can only be calculated if the product has a minimum thickness :

$$\Delta_p \geq \Delta_{p, \min}$$

A0028864

This is equivalent to the following condition for the product level:

$$L_p - V \geq \Delta_{p, \min} + H_{p1} = L_{\min}$$

A0028863

L<sub>min</sub> is defined in the **Minimum level** parameter (→  201). As can be seen from the formula it always must be bigger than H<sub>p1</sub>.

If L<sub>p</sub> - V falls below this limit, the density is calculated as follows:

- If a previous calculated value is available, this value will be kept as long as no new calculation is possible.
- If no value was previously calculated, the manual value (defined in the **Manual upper density** parameter) will be used.

*Hysteresis*

The level of the product in a tank is not constant but slightly varies, due for example to filling disturbances. If the level oscillates around the changeover level (**Minimum level** (→  201)), the algorithm will constantly switch between calculating the value and holding the previous result. To avoid this effect a positional hysteresis is defined around the changeover point.

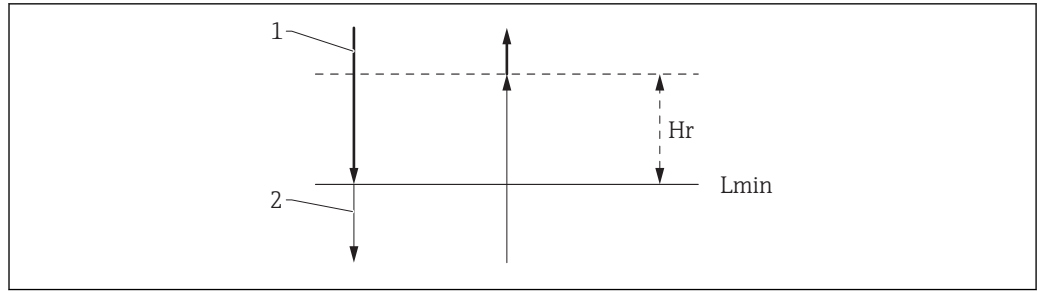

A0029148

53 HTMS hysteresis

- 1 Value calculated
- 2 Value held/manual
- $L_{min}$  Minimum level (→ 201)
- $H_r$  Hysteresis (→ 202)

Description of parameters

Navigation Setup → Advanced setup → Application → Tank calculation → HTMS

HTMS mode

Navigation Setup → Advanced setup → Application → Tank calculation → HTMS → HTMS mode

Description Defines the HTMS mode. Depending on the mode one or two pressure transmitters are used.

- Selection
- HTMS P1
  - HTMS P1+P3

Factory setting HTMS P1

Additional information

|              |             |
|--------------|-------------|
| Read access  | Operator    |
| Write access | Maintenance |

Meaning of the options

- HTMS P1  
Only a bottom pressure transmitter (P1) is used.
- HTMS P1+P3  
A bottom (P1) and top (P3) pressure transmitter are used. This option should be selected for pressurized tanks.

Manual density

Navigation Setup → Advanced setup → Application → Tank calculation → HTMS → Manual density

Description Defines the manual density.



**User entry** 0 to 3 000 kg/m<sup>3</sup>

**Factory setting** 800 kg/m<sup>3</sup>

**Additional information**

|              |             |
|--------------|-------------|
| Read access  | Maintenance |
| Write access | Maintenance |

**Density value**

**Navigation**  Setup → Advanced setup → Application → Tank calculation → HTMS → Density value

**Description** Shows the calculated product density.

**Additional information**

|              |          |
|--------------|----------|
| Read access  | Operator |
| Write access | -        |

**Minimum level** 

**Navigation**  Setup → Advanced setup → Application → Tank calculation → HTMS → Minimum level

**Description** Defines the minimum product level for a HTMS calculation. If Lp - V falls below the limit defined in this parameter, the density retains its last value or the manual value is used instead.

**User entry** 0 to 20 000 mm

**Factory setting** 7 000 mm

**Additional information**

|              |             |
|--------------|-------------|
| Read access  | Operator    |
| Write access | Maintenance |

**Minimum pressure** 

**Navigation**  Setup → Advanced setup → Application → Tank calculation → HTMS → Minimum pressure

**Description** Defines the minimum pressure for a HTMS calculation. If the pressure P1 (or the difference P1 - P3) falls below the limit defined in this parameter, the density retains its last value or the manual value is used instead.

**User entry** 0 to 100 bar

**Factory setting** 0.1 bar

**Additional information**

|              |             |
|--------------|-------------|
| Read access  | Operator    |
| Write access | Maintenance |

**Safety distance****Navigation**

Setup → Advanced setup → Application → Tank calculation → HTMS → Safety distance

**Description**

Defines the minimum level which must be present above the bottom pressure sensor before its signal is used for the calculation.

**User entry**

0 to 10 000 mm

**Factory setting**

2 000 mm

**Additional information**

|              |             |
|--------------|-------------|
| Read access  | Operator    |
| Write access | Maintenance |

**Hysteresis****Navigation**

Setup → Advanced setup → Application → Tank calculation → HTMS → Hysteresis

**Description**

Defines the hysteresis for the HTMS calculation. Prevents constant switching if the level is near the switch-over point.

**User entry**

0 to 2 000 mm

**Factory setting**

50 mm

**Additional information**

|              |             |
|--------------|-------------|
| Read access  | Operator    |
| Write access | Maintenance |

**Water density****Navigation**

Setup → Advanced setup → Application → Tank calculation → HTMS → Water density

**Description**

Density of the water in the tank.

**User entry**

Signed floating-point number

**Factory setting**

1 000 kg/m<sup>3</sup>

**Additional information**







|              |             |
|--------------|-------------|
| Read access  | Operator    |
| Write access | Maintenance |

*"Dip-table" submenu**Dip table*

The dip table is used to correct the level readings using independently taken hand dips. The dip table is used in particular to adapt the level gauge to the specific application conditions such as a mechanical offset and the tank or stilling well design. Depending on national regulations, national inspectors will dip the tank at one to three levels during a calibration run and check the level readings.

Only one value pair must be entered into the dip table to correct the measurement offset. If a second value pair is entered into the dip table, the device accepts the corrected measured values identically for both value pairs. All other measured values are determined by linear extrapolation.

If more than two value pairs are entered, the system carries out a linear interpolation between adjacent value pairs. Outside these value pairs, extrapolation is also linear.

-  The offset should **not** be determined and entered within the close range of the antenna or immediately in the range of the tank bottom, because within these ranges interferences of the radar signal may occur.
- The entries of the dip table must be arranged in an ascending order of levels. If table values have not been entered in the correct order, they can automatically be rearranged by selecting **Table settings** (→  **207**) = **Sort table**
-  After changing the **Empty** parameter (→  **121**), the **Table mode** parameter (→  **207**) is automatically set to **Disable**.
- If **Empty** (→  **121**) has been changed by more than 20 mm (0.8 in), it is recommended to delete the dip table.
- The dip table values are not affected by a change of the **Empty** parameter (→  **121**).

*Semiautomatic creation of a dip table*

In order not to mix up measurement values corrected by the dip table with uncorrected measurement values, it is recommended to enter new data pairs semiautomatically into the table. This means: the uncorrected level is measured by the device and the user only enters the corresponding dip value.

The first dip value should be entered immediately after the basic calibration. Further dip points should be entered only after a level change of at least 2 m (6.6 ft) and a deviation between the uncorrected measurement value and the hand dip value of at least 4 mm (0.16 in).

If this procedure can not be followed, then **no** value pair should be entered into the dip table after basic calibration. Measurement data and hand dip values should be collected over the full measurement range and be evaluated with regard to a good linear fit. Only then characteristic value pairs should be entered into the dip table using the "manual mode" (see below).

*Manual creation of a dip table*

Before creating a dip table manually, measured levels and dip values should be collected over the full measurement range and be evaluated with regard to a linear fit. Only then characteristic value pairs from this fit should be entered into the dip table using the manual mode. In the manual mode both, the measured level (without correction) and the corresponding dip value are entered by the user.

-  If further linearisation is needed, further hand dip values should be entered using only the "semi-automatic" mode (see above).

*The table editor on the local display*

1. Navigate to Setup → Advanced setup → Application → Tank calculation → Dip-table → Table mode and select the **Disable** option.
2. Navigate to Setup → Advanced setup → Application → Calculation → Dip-table → Edit table

↳

| ././Edit table |               | 13953-1       |  |
|----------------|---------------|---------------|--|
| N              | Dip Table De. | Dip Table Di. |  |
| 1              | 10.0          | 10.1          |  |
| 2              | 5.0           | 4.2           |  |
| 3              | 1.0           | 1.0           |  |

↑   ↓   E

A0029166-EN

54 The dip table editor on the local display

N Number of the line  
 De. Device level  
 Di. Dip level

3. Use the "↑" and "↓" keys to move to the line you want to edit.

↳

| ././Edit table |               | 13964-1       |  |
|----------------|---------------|---------------|--|
| N              | Dip Table De. | Dip Table Di. |  |
| 3              | 1.0           | 1.0           |  |
| 4              | 0.0           | 0.0           |  |
| 5              | 0.0           | 0.0           |  |

↑   ↓   E

A0029167-EN

4. Press "E" to open the line.
5. Use "→" to select the cell you want to edit.

↳

| ././Edit table |               | 13964-1       |  |
|----------------|---------------|---------------|--|
| N              | Dip Table De. | Dip Table Di. |  |
| 3              | 1.0           | 1.0           |  |
| 4              | 0.0           | 0.0           |  |
| 5              | 0.0           | 0.0           |  |

↑   →   E

A0029168-EN

6. Press "E" to open the cell.
7. Enter the required number → 43.
8. Continue until all required table points have been entered.
9. Press "-" and "+" simultaneously to quit the table editor.
10. Navigate to Setup → Advanced setup → Application → Tank calculation → Dip-table → Table settings and select the **Sort table** option.
  - ↳ The table points are arranged in an ascending order.
11. Navigate to Setup → Advanced setup → Application → Tank calculation → Dip-table → Table mode and select the **Enable** option.
  - ↳ The new dip table is active.

The table editor in FieldCare

**i** In the FieldCare table editor the dip table can only be entered manually. Even if the semiautomatic method has been selected in the **Table settings** parameter (→ 207), the complete table will be written from the editor to the device in the manual mode.

1.

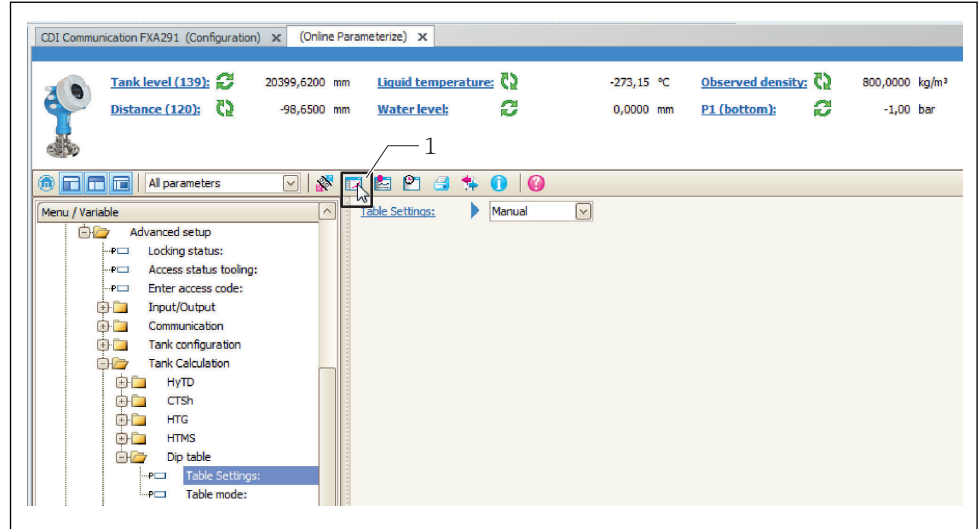

A0029162

1 Table icon; calls up the table editor.

Open the table editor by clicking on the table icon.

↳ The graphical table editor appears:

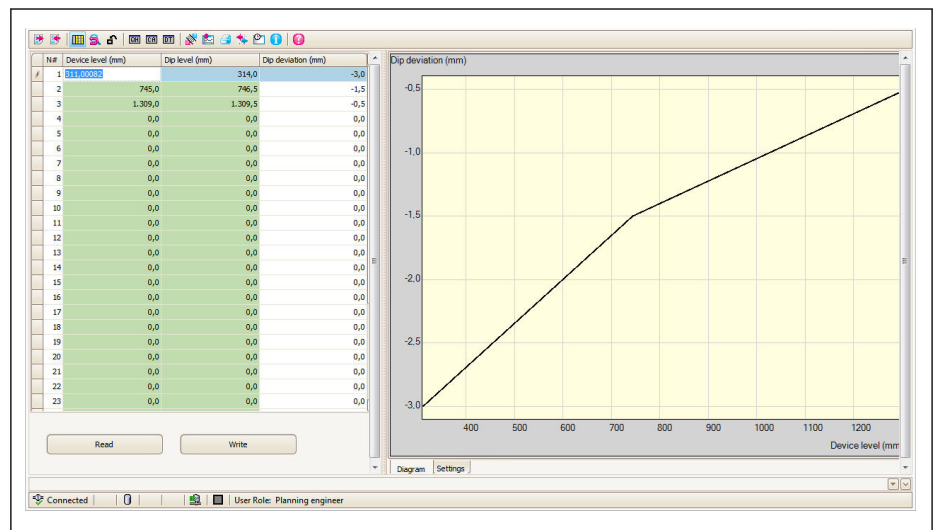

A0029161

2. If the device already contains a dip table: Click "Read" to load it into the editor.
3. Enter or change table values in the table on the right. A graphical representation of the table is shown in the diagram on the right.
4. Click "Write" to write the table back to the device.

*Description of parameters*

*Navigation*       Setup → Advanced setup → Application → Tank calculation → Dip-table

---

**Table settings** 

---

**Navigation**       Setup → Advanced setup → Application → Tank calculation → Dip-table → Table settings

**Description**      Defines the dip-table operation to be performed.

- Selection**
- Manual
  - Semiautomatic
  - Clear table
  - Sort table

**Factory setting**      Manual

**Additional information**

|              |             |
|--------------|-------------|
| Read access  | Operator    |
| Write access | Maintenance |

**Meaning of the options**

- Manual  
Both, the device level and the dip level for each table point have to be entered manually.
- Semiautomatic  
The device level of each table point is measured by the device itself, the corresponding dip level must be entered manually.
- Clear table  
Deletes the complete dip table.
- Sort table  
Sorts the table points into an ascending order. This must be performed if table values have not been entered in the correct order.

---

**Table mode** 

---

**Navigation**       Setup → Advanced setup → Application → Tank calculation → Dip-table → Table mode

**Description**      Enables or disables the dip-table.

- Selection**
- Disable
  - Enable

**Factory setting**      Disable

**Additional information**

|              |             |
|--------------|-------------|
| Read access  | Operator    |
| Write access | Maintenance |



*"Alarm" submenu*

*Navigation*       Setup → Advanced setup → Application → Alarm → Alarm → Alarm mode

---

**Alarm mode**



**Navigation**       Setup → Advanced setup → Application → Alarm → Alarm → Alarm mode

**Description**      Defines the alarm mode of the selected alarm.

- Selection**
- Off
  - On
  - Latching

**Factory setting**      Off

**Additional information**

|                     |             |
|---------------------|-------------|
| <b>Read access</b>  | Operator    |
| <b>Write access</b> | Maintenance |

*Meaning of the options*

- **Off**  
No alarms are generated.
- **On**  
An alarm disappears if the alarm condition is no longer present (taking into consideration the hysteresis).
- **Latching**  
All alarms remain active until the user selects **Clear alarm** (→  215) = **Yes** or the power is switched off and on.

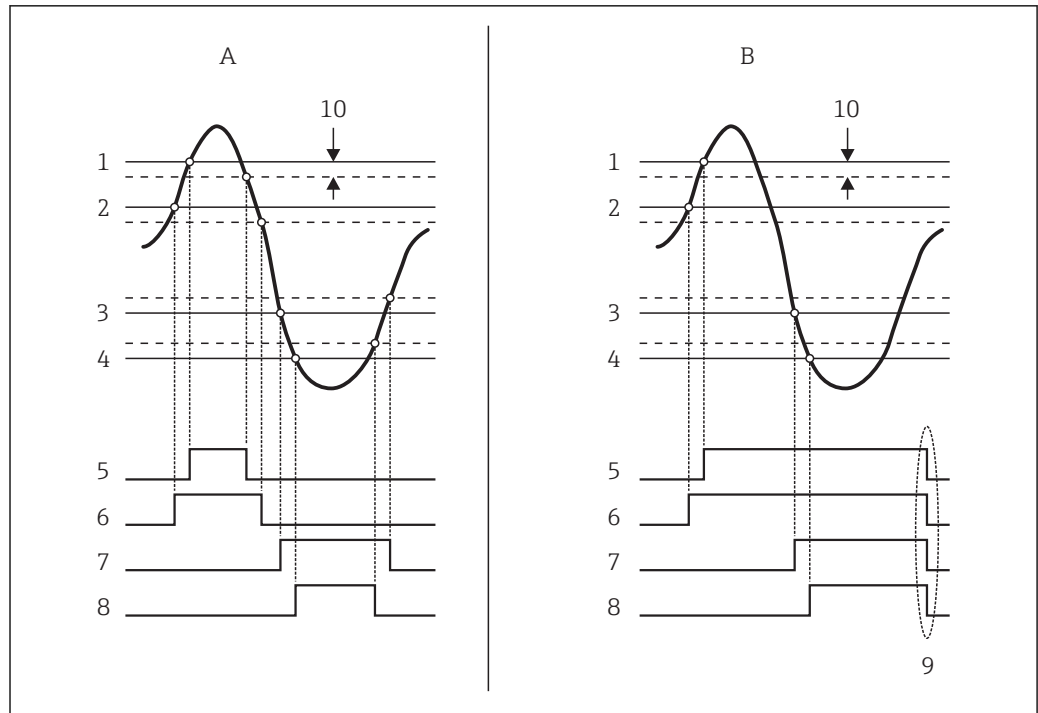

A0029539

55 Principle of the limit evaluation

- A Alarm mode (→ 209) = On
- B Alarm mode (→ 209) = Latching
- 1 HH alarm value (→ 212)
- 2 H alarm value (→ 212)
- 3 L alarm value (→ 213)
- 4 LL alarm value (→ 213)
- 5 HH alarm (→ 213)
- 6 H alarm (→ 214)
- 7 L alarm (→ 214)
- 8 LL alarm (→ 214)
- 9 "Clear alarm (→ 215)" = "Yes" or power off-on
- 10 Hysteresis (→ 216)

**Error value**



**Navigation**

Setup → Advanced setup → Application → Alarm → Alarm → Error value

**Prerequisite**

Alarm mode (→ 209) ≠ Off

**Description**

Defines the alarm to be issued if the input value is invalid.

**Selection**

- No alarm
- HH+H alarm
- H alarm
- L alarm
- LL+L alarm
- All alarms

**Factory setting**

All alarms

**Additional information**

|              |             |
|--------------|-------------|
| Read access  | Operator    |
| Write access | Maintenance |

**Alarm value source**



**Navigation** Setup → Advanced setup → Application → Alarm → Alarm → Alarm value source

**Prerequisite** **Alarm mode (→ 209) ≠ Off**

**Description** Determines the process variable to be monitored.

- Selection**
- Tank level
  - Liquid temperature
  - Vapor temperature
  - Water level
  - P1 (bottom)
  - P2 (middle)
  - P3 (top)
  - Observed density value
  - Volume
  - Flow velocity
  - Volume flow
  - Vapor density
  - Middle density
  - Upper density
  - Correction
  - Tank level %
  - GP 1...4 value
  - Measured level
  - P3 position
  - Tank reference height
  - Local gravity
  - P1 position
  - Manual density
  - Tank ullage
  - Average profile density
  - Lower density
  - Upper interface level
  - Lower interface level
  - Bottom level
  - Displacer position
  - HART device 1...15 PV
  - HART device 1...15 SV
  - HART device 1...15 TV
  - HART device 1...15 QV
  - HART device 1...15 PV mA
  - HART device 1...15 PV %
  - Element temperature 1...24
  - AIO B1-3 value
  - AIO C1-3 value
  - AIP B4-8 value
  - AIP C4-8 value
  - None

**Factory setting** None

**Additional information**

|              |             |
|--------------|-------------|
| Read access  | Operator    |
| Write access | Maintenance |

**Alarm value**

**Navigation**  Setup → Advanced setup → Application → Alarm → Alarm → Alarm value

**Prerequisite** **Alarm mode (→  209) ≠ Off**

**Description** Shows the current value of the process variable being monitored.

**User interface** Signed floating-point number

**Factory setting** 0 None

**Additional information**

|              |          |
|--------------|----------|
| Read access  | Operator |
| Write access | -        |

**HH alarm value**



**Navigation**  Setup → Advanced setup → Application → Alarm → Alarm → HH alarm value

**Prerequisite** **Alarm mode (→  209) ≠ Off**

**Description** Defines the high-high(HH) limit value.

**User entry** Signed floating-point number

**Factory setting** 0 None

**Additional information**

|              |             |
|--------------|-------------|
| Read access  | Operator    |
| Write access | Maintenance |

**H alarm value**



**Navigation**  Setup → Advanced setup → Application → Alarm → Alarm → H alarm value

**Prerequisite** **Alarm mode (→  209) ≠ Off**

**Description** Defines the high(H) limit value.

**User entry** Signed floating-point number

**Factory setting** 0 None

**Additional information**

|              |             |
|--------------|-------------|
| Read access  | Operator    |
| Write access | Maintenance |

**L alarm value**



**Navigation** Setup → Advanced setup → Application → Alarm → Alarm → L alarm value

**Prerequisite** **Alarm mode (→ 209) ≠ Off**

**Description** Defines the low limit value.

**User entry** Signed floating-point number

**Factory setting** 0 None

**Additional information**

|              |             |
|--------------|-------------|
| Read access  | Operator    |
| Write access | Maintenance |

**LL alarm value**



**Navigation** Setup → Advanced setup → Application → Alarm → Alarm → LL alarm value

**Prerequisite** **Alarm mode (→ 209) ≠ Off**

**Description** Defines the low-low(LL) limit value.

**User entry** Signed floating-point number

**Factory setting** 0 None

**Additional information**

|              |             |
|--------------|-------------|
| Read access  | Operator    |
| Write access | Maintenance |

**HH alarm**

**Navigation** Setup → Advanced setup → Application → Alarm → Alarm → HH alarm

**Prerequisite** **Alarm mode (→ 209) ≠ Off**

**Description** Shows whether an HH alarm is currently active.

**Additional information**

|              |          |
|--------------|----------|
| Read access  | Operator |
| Write access | -        |

---

**H alarm**

---

**Navigation**  Setup → Advanced setup → Application → Alarm → Alarm → H alarm

**Prerequisite** **Alarm mode (→  209) ≠ Off**

**Description** Shows whether an H alarm is currently active.

**Additional information**

|              |          |
|--------------|----------|
| Read access  | Operator |
| Write access | -        |

---

**HH+H alarm**

---

**Navigation**  Setup → Advanced setup → Application → Alarm → Alarm → HH+H alarm

**Prerequisite** **Alarm mode (→  209) ≠ Off**

**Description** Shows whether an HH or H alarm is currently active.

**Additional information**

|              |          |
|--------------|----------|
| Read access  | Operator |
| Write access | -        |

---

**L alarm**

---

**Navigation**  Setup → Advanced setup → Application → Alarm → Alarm → L alarm

**Prerequisite** **Alarm mode (→  209) ≠ Off**

**Description** Shows whether an L alarm is currently active.

**Additional information**

|              |          |
|--------------|----------|
| Read access  | Operator |
| Write access | -        |

---

**LL alarm**

---

**Navigation**  Setup → Advanced setup → Application → Alarm → Alarm → LL alarm

**Prerequisite** **Alarm mode (→  209) ≠ Off**

**Description** Shows whether an LL alarm is currently active.

**Additional information**

|              |          |
|--------------|----------|
| Read access  | Operator |
| Write access | -        |

**LL+L alarm**

**Navigation**

 Setup → Advanced setup → Application → Alarm → Alarm → LL+L alarm

**Prerequisite**

**Alarm mode (→  209) ≠ Off**

**Description**

Shows whether an LL or L alarm is currently active.

**Additional information**

|              |          |
|--------------|----------|
| Read access  | Operator |
| Write access | -        |

**Any error**

**Navigation**

 Setup → Advanced setup → Application → Alarm → Alarm → Any error

**Prerequisite**

**Alarm mode (→  209) ≠ Off**

**Description**

Show whether any alarm is currently active.

**User interface**

- Unknown
- Inactive
- Active
- Error

**Factory setting**

Unknown

**Additional information**

|              |          |
|--------------|----------|
| Read access  | Operator |
| Write access | -        |

**Clear alarm**



**Navigation**

 Setup → Advanced setup → Application → Alarm → Alarm → Clear alarm

**Prerequisite**

**Alarm mode (→  209) = Latching**

**Description**

Deletes an alarm which is still active although the alarm condition is no longer present.

**Selection**

- No
- Yes

**Factory setting**

No

**Additional information**

|              |             |
|--------------|-------------|
| Read access  | Operator    |
| Write access | Maintenance |

**Alarm hysteresis****Navigation**

Setup → Advanced setup → Application → Alarm → Alarm → Alarm hysteresis

**Prerequisite**

**Alarm mode** (→ 209) ≠ Off

**Description**

Defines the hysteresis for the limit values. The hysteresis prevents constant changes of the alarm state if the level is near one of the limit values.

**User entry**

Signed floating-point number

**Factory setting**

0.001

**Additional information**

|              |             |
|--------------|-------------|
| Read access  | Maintenance |
| Write access | Maintenance |

**Damping factor****Navigation**

Setup → Advanced setup → Application → Alarm → Alarm → Damping factor

**Description**

Defines the damping constant (in seconds).

**User entry**

0 to 999.9 s

**Factory setting**

0 s

**Additional information**

|              |             |
|--------------|-------------|
| Read access  | Operator    |
| Write access | Maintenance |



**"Safety settings" submenu**

Navigation  Setup → Advanced setup → Safety settings

**Output echo lost** 

**Navigation**  Setup → Advanced setup → Safety settings → Output echo lost

**Description** Defines the output behavior in case of a lost echo.

**Additional information**

|              |          |
|--------------|----------|
| Read access  | Operator |
| Write access | Service  |

**Meaning of the options**

- **Last valid value**  
The last value before the occurrence of the echo is kept.
- **Alarm**  
The device generates an alarm.

**Delay time echo lost** 

**Navigation**  Setup → Advanced setup → Safety settings → Delay time echo lost

**Description** Time between the echo loss and the reaction defined for the output.

**User entry** 0 to 99 999.9 s

**Factory setting** 60.0 s

**Additional information**

|              |             |
|--------------|-------------|
| Read access  | Operator    |
| Write access | Maintenance |

**Safety distance** 

**Navigation**  Setup → Advanced setup → Safety settings → Safety distance

**Description** Defines the safety distance (measured from the reference point). A warning is issued if the level rises into the safety distance.

**User entry** Signed floating-point number

**Factory setting** 0 mm

**Additional information**

|              |             |
|--------------|-------------|
| Read access  | Operator    |
| Write access | Maintenance |

**"Sensor config" submenu**

*Navigation*       Setup → Advanced setup → Sensor config

**Tube diameter** 

**Navigation**       Setup → Advanced setup → Sensor config → Tube diameter

**Description**      Enter diameter of stilling well.

**User entry**      Positive floating-point number

**Factory setting**      150 mm

**Additional information**

|                     |             |
|---------------------|-------------|
| <b>Read access</b>  | Operator    |
| <b>Write access</b> | Maintenance |

*"Information" submenu*

*Navigation*       Setup → Advanced setup → Sensor config → Information

**Signal quality**

**Navigation**       Setup → Advanced setup → Sensor config → Information → Signal quality

**Description**      Shows the quality of the evaluated level signal.

**Additional information**

|                     |          |
|---------------------|----------|
| <b>Read access</b>  | Operator |
| <b>Write access</b> | -        |

**Absolute echo amplitude**

**Navigation**       Setup → Advanced setup → Sensor config → Information → Absolute echo amplitude

**Description**      Shows the absolute amplitude of the evaluated level signal.

**Additional information**

|                     |          |
|---------------------|----------|
| <b>Read access</b>  | Operator |
| <b>Write access</b> | -        |

---

**Relative echo amplitude**

---

**Navigation**  Setup → Advanced setup → Sensor config → Information → Relative echo amplitude

**Description** Shows the relative amplitude (i.e. the distance to the evaluation curve) of the evaluated level signal.

**Additional information**

|              |          |
|--------------|----------|
| Read access  | Operator |
| Write access | -        |

---

**Distance**

---

**Navigation**  Setup → Advanced setup → Sensor config → Information → Distance

**Description** Distance from lower edge of device flange to product surface.

**Additional information**

|              |          |
|--------------|----------|
| Read access  | Operator |
| Write access | -        |

*"Echo tracking" submenu*

Navigation  Setup → Advanced setup → Sensor config → Echo tracking

**Evaluation mode** 

**Navigation**  Setup → Advanced setup → Sensor config → Echo tracking → Evaluation mode

**Description** Defines the evaluation mode for the echo tracking.

- Selection**
- Short time history
  - History off

**Factory setting** Short time history

**Additional information**

|              |             |
|--------------|-------------|
| Read access  | Operator    |
| Write access | Maintenance |

**Meaning of the options**

- **Short time history**  
In addition to the static algorithms a dynamic echo trace is continuously generated and evaluated.
- **History off**  
The envelope curve is evaluated only statically.

**History reset** 

**Navigation**  Setup → Advanced setup → Sensor config → Echo tracking → History reset

**Description** Resets the history of the echo tracking.

- Selection**
- Reset done
  - Restart echo tracking
  - Delete history

**Factory setting** Reset done

**Additional information**

|              |             |
|--------------|-------------|
| Read access  | Operator    |
| Write access | Maintenance |

**"Display" submenu**

This menu is only visible if the device has a local display.

*Navigation*       Setup → Advanced setup → Display

**Language****Navigation**

 Setup → Advanced setup → Display → Language

**Prerequisite**

The device has a local display.

**Description**

Set display language.

**Selection**

- English
- Deutsch \*
- Français \*
- Español \*
- Italiano \*
- Nederlands \*
- Portuguesa \*
- Polski \*
- русский язык (Russian) \*
- Svenska \*
- Türkçe \*
- 中文 (Chinese) \*
- 日本語 (Japanese) \*
- 한국어 (Korean) \*
- العربية (Arabic) \*
- Bahasa Indonesia \*
- ภาษาไทย (Thai) \*
- tiếng Việt (Vietnamese) \*
- čeština (Czech) \*

**Factory setting**

English

**Additional information**

|              |          |
|--------------|----------|
| Read access  | Operator |
| Write access | Operator |

**Format display****Navigation**

 Setup → Advanced setup → Display → Format display

**Prerequisite**

The device has a local display.

**Description**

Select how measured values are shown on the display.



\* Visibility depends on order options or device settings

- Selection**
- 1 value, max. size
  - 1 bargraph + 1 value
  - 2 values
  - 1 value large + 2 values
  - 4 values

**Factory setting** 1 value, max. size

**Additional information**



|              |          |
|--------------|----------|
| Read access  | Operator |
| Write access | Operator |

- The **Value 1 to 4 display** (→  223) parameters specify which measured values are shown on the display and in which order.
- If more measured values are specified than the current display mode permits, the values alternate on the device display. The display time until the next change is configured in the **Display interval** parameter (→  226).

---

**Value 1 to 4 display**



**Navigation**   Setup → Advanced setup → Display → Value 1 display

**Prerequisite** The device has a local display.

**Description** Select the measured value that is shown on the local display.

- Selection**
- None <sup>9)</sup>
  - Tank level
  - Measured level
  - Tank level %
  - Water level <sup>9)</sup>
  - Liquid temperature <sup>9)</sup>
  - Vapor temperature <sup>9)</sup>
  - Air temperature <sup>9)</sup>
  - Tank ullage
  - Tank ullage %
  - Observed density value <sup>9)</sup>
  - P1 (bottom) <sup>9)</sup>
  - P2 (middle) <sup>9)</sup>
  - P3 (top) <sup>9)</sup>
  - GP 1 value <sup>9)</sup>
  - GP 2 value <sup>9)</sup>
  - GP 3 value <sup>9)</sup>
  - GP 4 value <sup>9)</sup>
  - Gauge command <sup>9)</sup>
  - Gauge status <sup>9)</sup>
  - AIO B1-3 value <sup>9)</sup>
  - AIO B1-3 value mA <sup>9)</sup>
  - AIO B1-3 value % <sup>9)</sup>
  - AIO C1-3 value <sup>9)</sup>
  - AIO C1-3 value mA <sup>9)</sup>
  - AIO C1-3 value % <sup>9)</sup>

---

<sup>9)</sup> not available for the **Value 1 display** parameter



- AIP B4-8 value <sup>9)</sup>
- AIP B4-8 value mA <sup>9)</sup>
- AIP B4-8 value % <sup>9)</sup>
- AIP C4-8 value <sup>9)</sup>
- AIP C4-8 value mA <sup>9)</sup>
- AIP C4-8 value % <sup>9)</sup>

**Factory setting**                      Depending on device version

**Additional information**

|              |             |
|--------------|-------------|
| Read access  | Operator    |
| Write access | Maintenance |

**Decimal places 1 to 4** 

**Navigation**                        Setup → Advanced setup → Display → Decimal places 1

**Prerequisite**                      The device has a local display.

**Description**                      This selection does not affect the measurement and calculation accuracy of the device.



- Selection**
- X
  - X.X
  - X.XX
  - X.XXX
  - X.XXXX

**Factory setting**                      x.x

**Additional information**

|              |             |
|--------------|-------------|
| Read access  | Operator    |
| Write access | Maintenance |

**Separator** 

**Navigation**                        Setup → Advanced setup → Display → Separator

**Prerequisite**                      The device has a local display.

**Description**                      Select decimal separator for displaying numerical values.

- Selection**
- .
  - ,

**Factory setting**                      .

**Additional information**

|              |             |
|--------------|-------------|
| Read access  | Operator    |
| Write access | Maintenance |



**Number format**



**Navigation** Setup → Advanced setup → Display → Number format

**Prerequisite** The device has a local display.

**Description** Choose number format for the display.

- Selection**
- Decimal
  - ft-in-1/16"

**Factory setting** Decimal

**Additional information**

|              |             |
|--------------|-------------|
| Read access  | Operator    |
| Write access | Maintenance |

The **ft-in-1/16"** option is only valid for distance values.

**Header**



**Navigation** Setup → Advanced setup → Display → Header

**Prerequisite** The device has a local display.

**Description** Select header contents on local display.

- Selection**
- Device tag
  - Free text

**Factory setting** Device tag

**Additional information**

|              |             |
|--------------|-------------|
| Read access  | Operator    |
| Write access | Maintenance |

**Meaning of the options**

- **Device tag**  
The header contents is defined in the **Device tag** parameter (→ 240).
- **Free text**  
The header contents is defined in the **Header text** parameter (→ 225).

**Header text**



**Navigation** Setup → Advanced setup → Display → Header text

**Prerequisite** **Header** (→ 225) = **Free text**

**Description** Enter display header text.

**Factory setting** TG-Platform



**Additional information**

|                     |             |
|---------------------|-------------|
| <b>Read access</b>  | Operator    |
| <b>Write access</b> | Maintenance |

---

## Display interval

---

**Navigation**   Setup → Advanced setup → Display → Display interval

**Description** Set time measured values are shown on display if display alternates between values.

**User entry** 1 to 10 s

**Factory setting** 5 s



**Additional information**

|                     |          |
|---------------------|----------|
| <b>Read access</b>  | Operator |
| <b>Write access</b> | Operator |

---

## Display damping

---

**Navigation**   Setup → Advanced setup → Display → Display damping

**Prerequisite** The device has a local display.

**Description** Set display reaction time to fluctuations in the measured value.

**User entry** 0.0 to 999.9 s

**Factory setting** 0.0 s



**Additional information**

|                     |             |
|---------------------|-------------|
| <b>Read access</b>  | Operator    |
| <b>Write access</b> | Maintenance |

---

## Backlight

---

**Navigation**   Setup → Advanced setup → Display → Backlight

**Prerequisite** The device has a local display.

**Description** Switch the local display backlight on and off.

**Selection**                   ▪ Disable  
                                      ▪ Enable

**Factory setting**            Enable

**Additional information**

|              |          |
|--------------|----------|
| Read access  | Operator |
| Write access | Operator |

---

**Contrast display**

---

**Navigation**                 Setup → Advanced setup → Display → Contrast display

**Prerequisite**               The device has a local display.

**Description**               Adjust local display contrast setting to ambient conditions (e.g. lighting or reading angle).

**User entry**                 20 to 80 %

**Factory setting**           30 %

**Additional information**

|              |          |
|--------------|----------|
| Read access  | Operator |
| Write access | Operator |

**"System units" submenu**

Navigation  Setup → Advanced setup → System units

**Units preset** 

**Navigation**  Setup → Advanced setup → System units → Units preset

**Description** Defines a set of units for length, pressure and temperature.





- Selection**
- mm, bar, °C
  - m, bar, °C
  - mm, PSI, °C
  - ft, PSI, °F
  - ft-in-16, PSI, °F
  - ft-in-8, PSI, °F
  - Customer value

**Factory setting** mm, bar, °C

**Additional information**

|              |             |
|--------------|-------------|
| Read access  | Operator    |
| Write access | Maintenance |

If the **Customer value** option is selected, the units are defined in the following parameters:

- Distance unit (→  228)
- Pressure unit (→  229)
- Temperature unit (→  229)
- Density unit (→  229)

In any other case these are read-only parameters used to indicate the respective unit.

**Distance unit** 

**Navigation**  Setup → Advanced setup → System units → Distance unit

**Description** Select distance unit.

- Selection**
- |  |  |
|--|--|
| <p><i>SI units</i></p> <ul style="list-style-type: none"> <li>■ m</li> <li>■ mm</li> <li>■ cm</li> </ul> | <p><i>US units</i></p> <ul style="list-style-type: none"> <li>■ ft</li> <li>■ in</li> <li>■ ft-in-16</li> <li>■ ft-in-8</li> </ul> |
|--|--|

**Factory setting** mm

**Additional information**

|              |   |
|--------------|---|
| Read access  | Operator  |
| Write access | Maintenance (if <b>Units preset</b> (→  120) = <b>Customer value</b> ) |

**Pressure unit**



**Navigation**      Setup → Advanced setup → System units → Pressure unit

**Description**      Select process pressure unit.

**Selection**

|  |                        |  |
|--|------------------------|--|
| <i>SI units</i><br>■ bar<br>■ Pa<br>■ kPa<br>■ MPa<br>■ mbar a | <i>US units</i><br>psi | <i>Other units</i><br>■ inH2O<br>■ inH2O (68°F)<br>■ ftH2O (68°F)<br>■ mmH2O<br>■ mmHg |
|--|------------------------|--|

**Factory setting**      bar

**Additional information**

|              |  |
|--------------|--|
| Read access  | Operator   |
| Write access | Maintenance (if <b>Units preset</b> (→  120) = <b>Customer value</b> ) |

**Temperature unit**



**Navigation**      Setup → Advanced setup → System units → Temperature unit

**Description**      Select temperature unit.

**Selection**

|                                |                                 |
|--------------------------------|---------------------------------|
| <i>SI units</i><br>■ °C<br>■ K | <i>US units</i><br>■ °F<br>■ °R |
|--------------------------------|---------------------------------|

**Factory setting**      °C

**Additional information**

|              |  |
|--------------|--|
| Read access  | Operator   |
| Write access | Maintenance (if <b>Units preset</b> (→  120) = <b>Customer value</b> ) |

**Density unit**



**Navigation**      Setup → Advanced setup → System units → Density unit

**Description**      Select density unit.

**Selection**

|  |  |                                       |
|--|--|---------------------------------------|
| <i>SI units</i><br>■ g/cm <sup>3</sup><br>■ g/ml<br>■ g/l<br>■ kg/l<br>■ kg/dm <sup>3</sup><br>■ kg/m <sup>3</sup> | <i>US units</i><br>■ lb/ft <sup>3</sup><br>■ lb/gal (us)<br>■ lb/in <sup>3</sup><br>■ STon/yd <sup>3</sup> | <i>Other units</i><br>■ °API<br>■ SGU |
|--|--|---------------------------------------|

**Factory setting**      kg/m<sup>3</sup>

**Additional information**

|              |  |
|--------------|--|
| Read access  | Operator   |
| Write access | Maintenance (if Units preset (→  120) = Customer value) |

**"Date / time" submenu**

*Navigation*       Setup → Advanced setup → Date / time

**Date/time**

**Navigation**       Setup → Advanced setup → Date / time → Date/time

**Description**      Displays the device internal real time clock.

**Additional information**

|              |          |
|--------------|----------|
| Read access  | Operator |
| Write access | -        |

**Set date**



**Navigation**       Setup → Advanced setup → Date / time → Set date

**Description**      Controls the setting of the real-time clock.

**Selection**

- Please select
- Abort
- Start
- Confirm time

**Factory setting**      Please select

**Additional information**

|              |             |
|--------------|-------------|
| Read access  | Operator    |
| Write access | Maintenance |

**Meaning of the options**

- **Please select**  
Prompts the user to select an action.
- **Abort**  
Discards the entered date and time.
- **Start**  
Starts the setting of the real time clock.
- **Confirm time**  
Sets the real-time clock to the entered date and time.

**Year**



**Navigation**       Setup → Advanced setup → Date / time → Year

**Prerequisite**      Set date (→  231) = Start

**Description** Enter the current year.

**User entry** 2 016 to 2 079

**Factory setting** 2 016

**Additional information**

|              |             |
|--------------|-------------|
| Read access  | Operator    |
| Write access | Maintenance |

---

**Month** 

---

**Navigation**  Setup → Advanced setup → Date / time → Month

**Prerequisite** **Set date (→  231) = Start**

**Description** Enter the current month.

**User entry** 1 to 12

**Factory setting** 1

**Additional information**

|              |             |
|--------------|-------------|
| Read access  | Operator    |
| Write access | Maintenance |

---

**Day** 

---

**Navigation**  Setup → Advanced setup → Date / time → Day

**Prerequisite** **Set date (→  231) = Start**

**Description** Enter the current day.

**User entry** 1 to 31

**Factory setting** 1

**Additional information**

|              |             |
|--------------|-------------|
| Read access  | Operator    |
| Write access | Maintenance |

---

**Hour** 

---

**Navigation**  Setup → Advanced setup → Date / time → Hour

**Prerequisite** **Set date (→  231) = Start**



**Description** Enter the current hour.

**User entry** 0 to 23

**Factory setting** 0

**Additional information**

|              |             |
|--------------|-------------|
| Read access  | Operator    |
| Write access | Maintenance |

---

## Minute



**Navigation** Setup → Advanced setup → Date / time → Minute

**Prerequisite** Set date (→ 231) = Start

**Description** Enter the current minute.

**User entry** 0 to 59

**Factory setting** 0

**Additional information**

|              |             |
|--------------|-------------|
| Read access  | Operator    |
| Write access | Maintenance |

**"SIL confirmation" wizard**

-  The **SIL confirmation** wizard is only available for devices with SIL or WHG approval (Feature 590: "Additional Approval", option LA: "SIL" or LC: "WHG overflow prevention" ) which are currently **not** in the SIL- or WHG-locked state.
- The **SIL confirmation** wizard is required to lock the device according to SIL or WHG. For details refer to the "Functional Safety Manual" of the respective device, which describes the locking procedure and the parameters of this wizard.

*Navigation*       Setup → Advanced setup → SIL confirmation

**"Deactivate SIL/WHG" wizard**

-  The **Deactivate SIL/WHG** wizard is only available for devices with SIL or WHG approval (Feature 590: "Additional Approval", option LA: "SIL" or LC: "WHG overflow prevention" ) which are currently in the SIL- or WHG-locked state.
- The **Deactivate SIL/WHG** wizard is required to undo the locking of the device according to SIL or WHG. For details refer to the "Functional Safety Manual" of the respective device, which describes the locking procedure and the parameters of this wizard.

*Navigation*       Setup → Advanced setup → Deactivate SIL/WHG

**"Administration" submenu**

Navigation  Setup → Advanced setup → Administration

**Define access code** 

**Navigation**  Setup → Advanced setup → Administration → Define access code





**Description** Define release code for write access to parameters.

**User entry** 0 to 9999

**Factory setting** 0

**Additional information**

|                     |             |
|---------------------|-------------|
| <b>Read access</b>  | Operator    |
| <b>Write access</b> | Maintenance |

-  If the factory setting is not changed or 0 is defined as the access code, the parameters are not write-protected and the configuration data of the device can then always be modified. The user is logged on in the *Maintenance* role.
-  The write protection affects all parameters marked with the  symbol in this document.
-  Once the access code has been defined, write-protected parameters can only be modified if the access code is entered in the **Enter access code** parameter.

**Device reset** 

**Navigation**   Setup → Advanced setup → Administration → Device reset

**Description** Reset the device configuration - either entirely or in part - to a defined state.

**Selection**

- Cancel
- To fieldbus defaults \*\*
- To factory defaults \*
- Restart device

**Factory setting** Cancel

**Additional information**

|                     |             |
|---------------------|-------------|
| <b>Read access</b>  | Operator    |
| <b>Write access</b> | Maintenance |

\*\* Visibility depends on communication  
 \* Visibility depends on order options or device settings

## 15.4 "Diagnostics" menu

Navigation  Diagnostics

---

### Actual diagnostics

---

**Navigation**  Diagnostics → Actual diagnostics

**Description** Shows the current occurred diagnostic event along with its diagnostic information.



**Additional information**

|              |          |
|--------------|----------|
| Read access  | Operator |
| Write access | -        |

The display consists of:

- Symbol for event behavior
- Code for diagnostic behavior
- Operating time of occurrence
- Event text

 If several messages are active at the same time, the messages with the highest priority is displayed.

 Information on what is causing the message, and remedy measures, can be viewed via the  symbol on the display.

---

### Timestamp

---

**Navigation**  Diagnostics → Timestamp

**Description** Displays the timestamp for the currently active diagnostic message.

**Additional information**

|              |          |
|--------------|----------|
| Read access  | Operator |
| Write access | -        |

---

### Previous diagnostics

---

**Navigation**  Diagnostics → Previous diagnostics

**Description** Shows the diagnostic event that occurred prior to the current diagnostic event along with its diagnostic information.

**Additional information**

|              |          |
|--------------|----------|
| Read access  | Operator |
| Write access | -        |

The display consists of:

- Symbol for event behavior
- Code for diagnostic behavior
- Operating time of occurrence
- Event text

 If several messages are active at the same time, the messages with the highest priority is displayed.

 Information on what is causing the message, and remedy measures, can be viewed via the ⓘ symbol on the display.

### Timestamp

**Navigation**  Diagnostics → Timestamp

**Description** Shows the timestamp of the previous diagnostic message.

**Additional information**

|              |          |
|--------------|----------|
| Read access  | Operator |
| Write access | -        |

### Operating time from restart

**Navigation**  Diagnostics → Operating time from restart

**Description** Shows the time the device has been in operation since the last device restart.

**Additional information**

|              |          |
|--------------|----------|
| Read access  | Operator |
| Write access | -        |

### Operating time

**Navigation**  Diagnostics → Operating time

**Description** Indicates how long the device has been in operation.

**Additional information**

|              |          |
|--------------|----------|
| Read access  | Operator |
| Write access | -        |

---

**Date/time**

---

**Navigation** Diagnostics → Date/time**Description**

Displays the device internal real time clock.

**Additional information**

|                     |          |
|---------------------|----------|
| <b>Read access</b>  | Operator |
| <b>Write access</b> | -        |



### 15.4.1 "Diagnostic list" submenu

*Navigation*        Diagnostics → Diagnostic list

---

#### Diagnostics 1 to 5

---

|                               |  |
|-------------------------------|--|
| <b>Navigation</b>             |   Diagnostics → Diagnostic list → Diagnostics 1 to 5 |
| <b>Description</b>            | Display the current diagnostics messages with the highest to fifth-highest priority.   |
| <b>Additional information</b> | The display consists of: <ul style="list-style-type: none"><li>■ Symbol for event behavior</li><li>■ Code for diagnostic behavior</li><li>■ Operating time of occurrence</li><li>■ Event text</li></ul>                |

---

#### Timestamp 1 to 5

---

|                    |   |
|--------------------|---|
| <b>Navigation</b>  |  Diagnostics → Diagnostic list → Timestamp |
| <b>Description</b> | Timestamp of the diagnostic message.  |

## 15.4.2 "Device information" submenu

Navigation  Diagnostics → Device information

---

### Device tag

---

Navigation  Diagnostics → Device information → Device tag

Description Shows the device tag.

Factory setting NMS8x

#### Additional information

|              |          |
|--------------|----------|
| Read access  | Operator |
| Write access | -        |

---

### Serial number

---

Navigation  Diagnostics → Device information → Serial number

Description Shows the serial number of the measuring device.

#### Additional information

|              |          |
|--------------|----------|
| Read access  | Operator |
| Write access | -        |

---

### Firmware version

---

Navigation  Diagnostics → Device information → Firmware version

Description Shows the device firmware version installed.

#### Additional information

|              |          |
|--------------|----------|
| Read access  | Operator |
| Write access | -        |

---

### Firmware CRC

---

Navigation  Diagnostics → Device information → Firmware CRC

Description Result of the cyclic redundancy check of the firmware.



**Additional information**

|              |          |
|--------------|----------|
| Read access  | Operator |
| Write access | -        |

**Weight and measures configuration CRC**

**Navigation**

 Diagnostics → Device information → Weight and measures configuration CRC

**Description**

Result of the cyclic redundancy check of the weights and measure relevant parameters.

**Additional information**

|              |          |
|--------------|----------|
| Read access  | Operator |
| Write access | -        |

**Device name**

**Navigation**

 Diagnostics → Device information → Device name

**Description**

Shows the name of the transmitter.

**Additional information**

|              |          |
|--------------|----------|
| Read access  | Operator |
| Write access | -        |

**Order code**



**Navigation**

 Diagnostics → Device information → Order code

**Description**

Shows the device order code.

**Additional information**

|              |          |
|--------------|----------|
| Read access  | Operator |
| Write access | Service  |

**Extended order code 1 to 3**



**Navigation**

 Diagnostics → Device information → Extended order code 1

**Description**

Display the three parts of the extended order code.

**Additional information**

|              |          |
|--------------|----------|
| Read access  | Operator |
| Write access | Service  |

The extended order code indicates the selected option of all ordering features and thus uniquely identifies the device.

### 15.4.3 "Simulation" submenu

|             |             |
|-------------|-------------|
| Read access | Maintenance |
|-------------|-------------|

Navigation  Diagnostics → Simulation

#### Device alarm simulation

**Navigation**   Diagnostics → Simulation → Device alarm simulation

**Description** Switch the device alarm on and off.

**Selection**

- Off
- On

**Factory setting** Off

**Additional information**

|              |             |
|--------------|-------------|
| Read access  | Operator    |
| Write access | Maintenance |

#### Diagnostic event simulation

**Navigation**   Diagnostics → Simulation → Diagnostic event simulation

**Description** Select a diagnostic event to simulate this event.

**Selection** The diagnostic events of the device

**Factory setting** Off

**Additional information**

|              |             |
|--------------|-------------|
| Read access  | Operator    |
| Write access | Maintenance |

 To terminate the simulation, select **Off**.

#### Simulation distance on

**Navigation**   Diagnostics → Simulation → Simulation distance on

**Description** Switches the distance simulation on or off.

**Selection**

- Off
- On

**Factory setting** Off

**Additional information**

|              |             |
|--------------|-------------|
| Read access  | Operator    |
| Write access | Maintenance |

**Simulation distance**



**Navigation** Diagnostics → Simulation → Simulation distance

**Prerequisite** **Simulation distance on (→ 243) = On**

**Description** Defines the distance value to be simulated.

**User entry** Signed floating-point number

**Factory setting** 0 mm

**Additional information**

|              |             |
|--------------|-------------|
| Read access  | Operator    |
| Write access | Maintenance |

**Current output simulation**



**Navigation** Diagnostics → Simulation → Current output 1 simulation

Diagnostics → Simulation → Current output 2 simulation

**Prerequisite**

- The device has an Anlog I/O module.
- **Operating mode (→ 140) = 4..20mA output or HART slave +4..20mA output**

**Description** Switches the simulation of the current on or off.

**Selection**

- Off
- On

**Factory setting** Off

**Additional information**

|              |             |
|--------------|-------------|
| Read access  | Operator    |
| Write access | Maintenance |

**Simulation value**



**Navigation** Diagnostics → Simulation → Simulation value

Diagnostics → Simulation → Simulation value

**Prerequisite** **Current output simulation (→ 244) = On**

**Description** Defines the current to be simulated.

**User entry** 3.4 to 23 mA

**Factory setting** The current at the time the simulation was started.

**Additional information**

|                     |             |
|---------------------|-------------|
| <b>Read access</b>  | Operator    |
| <b>Write access</b> | Maintenance |

## 15.4.4 "Device check" submenu

Navigation  Diagnostics → Device check

---

### Start device check

---

**Navigation**  Diagnostics → Device check → Start device check

**Description** Starts the device check.

**Selection**

- No
- Yes

**Factory setting** No

**Additional information**

|              |             |
|--------------|-------------|
| Read access  | Operator    |
| Write access | Maintenance |

---

### Result device check

---

**Navigation**  Diagnostics → Device check → Result device check

**Description** Shows the overall result of the device check.

**Additional information**

|              |          |
|--------------|----------|
| Read access  | Operator |
| Write access | -        |

The device has a function that detects and reports any interference by unfavorable installation situation. Here, the amplitudes of measured signals are monitored, which refer to interference in the near range.

---

### Level signal

---

**Navigation**  Diagnostics → Device check → Level signal

**Prerequisite** Only visible after a device check.

**Description** Shows the result of the device check for the level signal.

**Additional information**

|              |          |
|--------------|----------|
| Read access  | Operator |
| Write access | -        |

---

**Near distance**

---

**Navigation** Diagnostics → Device check → Near distance**Prerequisite**

Only visible after a device check

**Description**

Shows the result of the device check for the near distance area.

**Additional information**

|                     |          |
|---------------------|----------|
| <b>Read access</b>  | Operator |
| <b>Write access</b> | -        |

# Index

## Symbols

#blank# (Parameter) . . . . . 129, 130

## 0 ... 9

0 % value (Parameter) . . . . . 136, 144, 166

100 % value (Parameter) . . . . . 136, 145, 166

## A

Absolute echo amplitude (Parameter) . . . . . 219

Access status tooling (Parameter) . . . . . 126

### Accessories

Communication specific . . . . . 101

Service specific . . . . . 101

Actual diagnostics (Parameter) . . . . . 236

Administration (Submenu) . . . . . 235

Advanced setup (Submenu) . . . . . 126

Air density (Parameter) . . . . . 116, 181

Air temperature (Parameter) . . . . . 113, 179

Air temperature source (Parameter) . . . . . 178

Alarm (Submenu) . . . . . 209

Alarm 1 input source (Parameter) . . . . . 162

Alarm 2 input source (Parameter) . . . . . 162

Alarm hysteresis (Parameter) . . . . . 216

Alarm mode (Parameter) . . . . . 209

Alarm value (Parameter) . . . . . 212

Alarm value source (Parameter) . . . . . 211

Ambient pressure (Parameter) . . . . . 187

Analog I/O (Submenu) . . . . . 140

Analog input 0% value (Parameter) . . . . . 146

Analog input 100% value (Parameter) . . . . . 146

Analog input source (Parameter) . . . . . 142

Analog IP (Submenu) . . . . . 134

Any error (Parameter) . . . . . 215

Application . . . . . 10

Residual risk . . . . . 10

Application (Submenu) . . . . . 174

Assign PV (Parameter) . . . . . 165

Assign QV (Parameter) . . . . . 170

Assign SV (Parameter) . . . . . 167

Assign TV (Parameter) . . . . . 169

## B

Backlight (Parameter) . . . . . 226

Baudrate (Parameter) . . . . . 156

Blocking distance (Parameter) . . . . . 176

Bus termination (Parameter) . . . . . 157

## C

Calibration temperature (Parameter) . . . . . 196

CE mark . . . . . 11

### Cleaning

Exterior cleaning . . . . . 97

Clear alarm (Parameter) . . . . . 215

Communication (Submenu) . . . . . 155

Communication interface protocol (Parameter) . . . . . 155

Communication interface protocol variant (Parameter) . . . . . 159

Communication status (Parameter) . . . . . 129

Configuration (Submenu) . . . . . 156, 159, 164

Confirm distance (Parameter) . . . . . 122

Contact type (Parameter) . . . . . 152

Contrast display (Parameter) . . . . . 227

Covered tank (Parameter) . . . . . 195

CTSh (Submenu) . . . . . 195

CTSh correction value (Parameter) . . . . . 195

CTSh mode (Parameter) . . . . . 195

Current output 1 simulation (Parameter) . . . . . 244

Current output 2 simulation (Parameter) . . . . . 244

Current span (Parameter) . . . . . 141

## D

Damping factor (Parameter) . . . . . 138, 148, 216

Date / time (Submenu) . . . . . 231

Date/time (Parameter) . . . . . 231, 238

Day (Parameter) . . . . . 232

DD . . . . . 53

Deactivate SIL/WHG (Wizard) . . . . . 234

Decimal places 1 (Parameter) . . . . . 224

Declaration of Conformity . . . . . 11

Define access code (Parameter) . . . . . 235

Deformation factor (Parameter) . . . . . 191

Delay time echo lost (Parameter) . . . . . 217

Density (Submenu) . . . . . 115, 181

Density unit (Parameter) . . . . . 229

Density value (Parameter) . . . . . 201

Designated use . . . . . 10

Device alarm simulation (Parameter) . . . . . 243

Device check (Submenu) . . . . . 246

Device Descriptions . . . . . 53

Device ID (Parameter) . . . . . 157

Device information (Submenu) . . . . . 240

Device name (Parameter) . . . . . 128, 241

Device replacement . . . . . 98

Device reset (Parameter) . . . . . 235

Device tag (Parameter) . . . . . 120, 128, 172, 240

Diagnostic event simulation (Parameter) . . . . . 243

Diagnostic events . . . . . 84

Diagnostic information

FieldCare . . . . . 87

Diagnostic list . . . . . 95

Diagnostic list (Submenu) . . . . . 239

Diagnostic message . . . . . 84

Diagnostics

Symbols . . . . . 84

Diagnostics (Menu) . . . . . 236

Diagnostics 1 to 5 (Parameter) . . . . . 239

Diagnostics event . . . . . 85

Digital input source (Parameter) . . . . . 151

Digital Xx-x (Submenu) . . . . . 150

DIP switch

see Write protection switch

Dip-table (Submenu) . . . . . 207

Display (Submenu) . . . . . 222



- Display damping (Parameter) . . . . . 226  
 Display interval (Parameter) . . . . . 226  
 Disposal . . . . . 99  
 Distance (Parameter) . . . . . 113, 125, 220  
 Distance unit (Parameter) . . . . . 228  
 Document  
   Function . . . . . 4  
 Document function . . . . . 4
- E**  
 Echo tracking (Submenu) . . . . . 221  
 Element position (Submenu) . . . . . 115  
 Element position 1 to 24 (Parameter) . . . . . 115  
 Element temperature (Submenu) . . . . . 114  
 Element temperature 1 to 24 (Parameter) . . . . . 114  
 Empty (Parameter) . . . . . 121, 174  
 Endress+Hauser services  
   Maintenance . . . . . 97  
   Repair . . . . . 99  
 Enter access code (Parameter) . . . . . 126  
 Error event type (Parameter) . . . . . 147  
 Error value (Parameter) . . . . . 144, 210  
 Evaluation mode (Parameter) . . . . . 221  
 Event level  
   Explanation . . . . . 84  
   Symbols . . . . . 84  
 Event text . . . . . 85  
 Expected SIL/WHG chain (Parameter) . . . . . 149  
 Extended order code 1 (Parameter) . . . . . 241  
 Exterior cleaning . . . . . 97
- F**  
 Failure mode (Parameter) . . . . . 143  
 Firmware CRC (Parameter) . . . . . 240  
 Firmware version (Parameter) . . . . . 240  
 Fixed current (Parameter) . . . . . 142  
 Float swap mode (Parameter) . . . . . 157  
 Forget device (Parameter) . . . . . 133  
 Forget device (Wizard) . . . . . 133  
 Format display (Parameter) . . . . . 222
- G**  
 Gauge current (Parameter) . . . . . 139  
 GP 1 name (Parameter) . . . . . 118  
 GP Value 1 (Parameter) . . . . . 118  
 GP Value 2 (Parameter) . . . . . 118  
 GP Value 3 (Parameter) . . . . . 118  
 GP Value 4 (Parameter) . . . . . 119  
 GP values (Submenu) . . . . . 118
- H**  
 H alarm (Parameter) . . . . . 214  
 H alarm value (Parameter) . . . . . 212  
 Hardware write protection . . . . . 47  
 HART date code (Parameter) . . . . . 173  
 HART descriptor (Parameter) . . . . . 172  
 HART Device(s) (Submenu) . . . . . 128  
 HART devices (Submenu) . . . . . 127  
 HART message (Parameter) . . . . . 173  
 HART output (Submenu) . . . . . 164
- HART short tag (Parameter) . . . . . 172  
 Header (Parameter) . . . . . 225  
 Header text (Parameter) . . . . . 225  
 HH alarm (Parameter) . . . . . 213  
 HH alarm value (Parameter) . . . . . 212  
 HH+H alarm (Parameter) . . . . . 214  
 History reset (Parameter) . . . . . 221  
 Hour (Parameter) . . . . . 232  
 HTMS (Submenu) . . . . . 200  
 HTMS mode (Parameter) . . . . . 200  
 Hysteresis (Parameter) . . . . . 202  
 HyTD (Submenu) . . . . . 190  
 HyTD correction value (Parameter) . . . . . 190  
 HyTD mode (Parameter) . . . . . 190
- I**  
 Information (Submenu) . . . . . 172, 219  
 Input value (Parameter) . . . . . 137, 144, 152  
 Input value % (Parameter) . . . . . 145  
 Input value in mA (Parameter) . . . . . 147  
 Input value percent (Parameter) . . . . . 148  
 Input/output (Submenu) . . . . . 127
- L**  
 L alarm (Parameter) . . . . . 214  
 L alarm value (Parameter) . . . . . 213  
 Language (Parameter) . . . . . 222  
 Level (Submenu) . . . . . 111, 174  
 Level mapping (Parameter) . . . . . 160  
 Level signal (Parameter) . . . . . 246  
 Line impedance (Parameter) . . . . . 161  
 Linear expansion coefficient (Parameter) . . . . . 196  
 Liquid temp source (Parameter) . . . . . 125, 177  
 Liquid temperature (Parameter) . . . . . 113, 178  
 LL alarm (Parameter) . . . . . 214  
 LL alarm value (Parameter) . . . . . 213  
 LL+L alarm (Parameter) . . . . . 215  
 Local display  
   see Diagnostics message  
   see In alarm condition  
 Locking status (Parameter) . . . . . 126  
 Lower interface level (Parameter) . . . . . 112
- M**  
 Maintenance . . . . . 97  
 Manual air temperature (Parameter) . . . . . 178  
 Manual density (Parameter) . . . . . 200  
 Manual liquid temperature (Parameter) . . . . . 177  
 Manual vapor temperature (Parameter) . . . . . 179  
 Manual water level (Parameter) . . . . . 176  
 Mapping end point (Parameter) . . . . . 124  
 Maximum probe temperature (Parameter) . . . . . 137  
 Measured level (Parameter) . . . . . 113  
 Measured lower density (Parameter) . . . . . 116  
 Measured materials . . . . . 10  
 Measured middle density (Parameter) . . . . . 116  
 Measured upper density (Parameter) . . . . . 116  
 Menu  
   Diagnostics . . . . . 236

|   |     |
|---|-----|
| Operation . . . . .                             | 111 |
| Setup . . . . .                                 | 120 |
| Minimum level (Parameter) . . . . .             | 201 |
| Minimum pressure (Parameter) . . . . .          | 201 |
| Minimum probe temperature (Parameter) . . . . . | 137 |
| Minute (Parameter) . . . . .                    | 233 |
| Month (Parameter) . . . . .                     | 232 |

**N**

|   |     |
|---|-----|
| Near distance (Parameter) . . . . .     | 247 |
| NMT element values (Submenu) . . . . .  | 114 |
| No. of preambles (Parameter) . . . . .  | 164 |
| Number format (Parameter) . . . . .     | 225 |
| Number of devices (Parameter) . . . . . | 127 |

**O**

|   |                    |
|---|--------------------|
| Observed density (Parameter) . . . . .            | 115, 181           |
| Observed density source (Parameter) . . . . .     | 181                |
| Operating elements                                |                    |
| Diagnostics message . . . . .                     | 85                 |
| Operating mode (Parameter) . . . . .              | 129, 134, 140, 150 |
| Operating time (Parameter) . . . . .              | 237                |
| Operating time from restart (Parameter) . . . . . | 237                |
| Operation (Menu) . . . . .                        | 111                |
| Operational safety . . . . .                      | 11                 |
| Order code (Parameter) . . . . .                  | 241                |
| Output density (Parameter) . . . . .              | 131                |
| Output echo lost (Parameter) . . . . .            | 217                |
| Output level (Parameter) . . . . .                | 132                |
| Output pressure (Parameter) . . . . .             | 130                |
| Output simulation (Parameter) . . . . .           | 152                |
| Output temperature (Parameter) . . . . .          | 131                |
| Output value (Parameter) . . . . .                | 145, 153           |
| Output values (Parameter) . . . . .               | 153                |
| Output vapor temperature (Parameter) . . . . .    | 132                |

**P**

|   |          |
|---|----------|
| P1 (bottom) (Parameter) . . . . .                 | 117, 183 |
| P1 (bottom) manual pressure (Parameter) . . . . . | 183      |
| P1 (bottom) source (Parameter) . . . . .          | 183      |
| P1 absolute / gauge (Parameter) . . . . .         | 184      |
| P1 offset (Parameter) . . . . .                   | 184      |
| P1 position (Parameter) . . . . .                 | 184      |
| P3 (top) (Parameter) . . . . .                    | 117, 185 |
| P3 (top) manual pressure (Parameter) . . . . .    | 185      |
| P3 (top) source (Parameter) . . . . .             | 185      |
| P3 absolute / gauge (Parameter) . . . . .         | 186      |
| P3 offset (Parameter) . . . . .                   | 186      |
| P3 position (Parameter) . . . . .                 | 186      |
| Parity (Parameter) . . . . .                      | 156      |
| Percent of range (Parameter) . . . . .            | 167      |
| Polling address (Parameter) . . . . .             | 128      |
| Present mapping (Parameter) . . . . .             | 124      |
| Pressure (Submenu) . . . . .                      | 117, 183 |
| Pressure unit (Parameter) . . . . .               | 229      |
| Previous diagnostics (Parameter) . . . . .        | 236      |
| Primary variable (PV) (Parameter) . . . . .       | 167      |
| Probe position (Parameter) . . . . .              | 138      |
| Process value (Parameter) . . . . .               | 135, 147 |

|  |          |
|--|----------|
| Process variable (Parameter) . . . . . | 136, 146 |
| Product safety . . . . .               | 11       |
| PV mA selector (Parameter) . . . . .   | 166      |
| PV source (Parameter) . . . . .        | 164      |

**Q**

|  |     |
|--|-----|
| Quaternary variable (QV) (Parameter) . . . . . | 171 |
|--|-----|

**R**

|   |     |
|---|-----|
| Readback value (Parameter) . . . . .          | 153 |
| Recalibration . . . . .                       | 97  |
| Record map (Parameter) . . . . .              | 124 |
| Relative echo amplitude (Parameter) . . . . . | 220 |
| Remedial measures                             |     |
| Calling up . . . . .                          | 86  |
| Closing . . . . .                             | 86  |
| Repair concept . . . . .                      | 98  |
| Replacing a device . . . . .                  | 98  |
| Requirements for personnel . . . . .          | 10  |
| Result device check (Parameter) . . . . .     | 246 |
| Return . . . . .                              | 99  |
| RTD connection type (Parameter) . . . . .     | 135 |
| RTD type (Parameter) . . . . .                | 134 |

**S**

|   |               |
|---|---------------|
| Safety distance (Parameter) . . . . .         | 202, 217      |
| Safety instructions                           |               |
| Basic . . . . .                               | 10            |
| Safety settings (Submenu) . . . . .           | 217           |
| Secondary variable (SV) (Parameter) . . . . . | 168           |
| Sensor config (Submenu) . . . . .             | 219           |
| Separator (Parameter) . . . . .               | 224           |
| Serial number (Parameter) . . . . .           | 240           |
| Set date (Parameter) . . . . .                | 231           |
| Set level (Parameter) . . . . .               | 122, 175      |
| Setup (Menu) . . . . .                        | 120           |
| Signal quality (Parameter) . . . . .          | 219           |
| SIL confirmation (Wizard) . . . . .           | 234           |
| Simulation (Submenu) . . . . .                | 243           |
| Simulation distance (Parameter) . . . . .     | 244           |
| Simulation distance on (Parameter) . . . . .  | 243           |
| Simulation value (Parameter) . . . . .        | 244           |
| Start device check (Parameter) . . . . .      | 246           |
| Starting level (Parameter) . . . . .          | 190           |
| Status signals . . . . .                      | 84, 87        |
| Stilling well (Parameter) . . . . .           | 196           |
| Submenu                                       |               |
| Administration . . . . .                      | 235           |
| Advanced setup . . . . .                      | 126           |
| Alarm . . . . .                               | 209           |
| Analog I/O . . . . .                          | 140           |
| Analog IP . . . . .                           | 134           |
| Application . . . . .                         | 174           |
| Communication . . . . .                       | 155           |
| Configuration . . . . .                       | 156, 159, 164 |
| CTSh . . . . .                                | 195           |
| Date / time . . . . .                         | 231           |
| Density . . . . .                             | 115, 181      |
| Device check . . . . .                        | 246           |

- Device information . . . . . 240
  - Diagnostic list . . . . . 239
  - Digital Xx-x . . . . . 150
  - Dip-table . . . . . 207
  - Display . . . . . 222
  - Echo tracking . . . . . 221
  - Element position . . . . . 115
  - Element temperature . . . . . 114
  - GP values . . . . . 118
  - HART Device(s) . . . . . 128
  - HART devices . . . . . 127
  - HART output . . . . . 164
  - HTMS . . . . . 200
  - HyTD . . . . . 190
  - Information . . . . . 172, 219
  - Input/output . . . . . 127
  - Level . . . . . 111, 174
  - NMT element values . . . . . 114
  - Pressure . . . . . 117, 183
  - Safety settings . . . . . 217
  - Sensor config . . . . . 219
  - Simulation . . . . . 243
  - System units . . . . . 228
  - Tank calculation . . . . . 188
  - Tank configuration . . . . . 174
  - Temperature . . . . . 113, 177
  - V1 input selector . . . . . 162
  - System components . . . . . 101
  - System polling address (Parameter) . . . . . 164
  - System units (Submenu) . . . . . 228
- T**
- Table mode (Parameter) . . . . . 207
  - Table settings (Parameter) . . . . . 207
  - Tank calculation (Submenu) . . . . . 188
  - Tank configuration (Submenu) . . . . . 174
  - Tank level (Parameter) . . . . . 111, 122, 175
  - Tank Level % (Parameter) . . . . . 111
  - Tank reference height (Parameter) . . . . . 121, 174
  - Tank ullage (Parameter) . . . . . 111
  - Tank ullage % (Parameter) . . . . . 112
  - Temperature (Submenu) . . . . . 113, 177
  - Temperature unit (Parameter) . . . . . 229
  - Tertiary variable (TV) (Parameter) . . . . . 169
  - Timestamp (Parameter) . . . . . 236, 237, 239
  - Trouble shooting . . . . . 83
  - Tube diameter (Parameter) . . . . . 121, 219
- U**
- Units preset (Parameter) . . . . . 120, 228
  - Upper interface level (Parameter) . . . . . 112
  - Used for SIL/WHG (Parameter) . . . . . 148, 154
- V**
- V1 address (Parameter) . . . . . 159, 160
  - V1 input selector (Submenu) . . . . . 162
  - Value 1 display (Parameter) . . . . . 223
  - Value percent selector (Parameter) . . . . . 163
  - Vapor density (Parameter) . . . . . 115, 182
  - Vapor temp source (Parameter) . . . . . 179
  - Vapor temperature (Parameter) . . . . . 114, 180
- W**
- Water density (Parameter) . . . . . 202
  - Water level (Parameter) . . . . . 112, 176
  - Water level source (Parameter) . . . . . 175
  - Weight and measures configuration CRC (Parameter) . . . . . 241
  - Wire expansion coefficient (Parameter) . . . . . 197
  - Wizard
    - Deactivate SIL/WHG . . . . . 234
    - Forget device . . . . . 133
    - SIL confirmation . . . . . 234
  - Workplace safety . . . . . 11
  - Write protection
    - Via write protection switch . . . . . 47
  - Write protection switch . . . . . 47
- Y**
- Year (Parameter) . . . . . 231



71410290

[www.addresses.endress.com](http://www.addresses.endress.com)

---