

**Operating instructions
for
Plastic Level Switch
for Liquids**

Model: NKP



1. Contents

1. Contents.....	2
2. Note	3
3. Instrument Inspection.....	3
4. Regulation Use	3
5. Operating Principle.....	4
6. Mechanical Connection.....	5
7. Electrical Connection	6
8. Technical Information.....	7
9. Order Codes	8
10. Dimensions	9
11. EU Declaration of Conformance	10
12. UK Declaration of Conformity.....	11

Manufactured and sold by:

KOBOLD Instruments Inc.
1801 Parkway View Drive
Pittsburgh PA 15205-1422
Tel.: 412-788-2830
Fax: 412-788-4980
E-Mail: info@koboldusa.com
Internet: www.koboldusa.com

2. Note

Please read these operating instructions before unpacking and putting the unit into operation. Follow the instructions precisely as described herein.

The devices are only to be used, maintained and serviced by persons familiar with these operating instructions and in accordance with local regulations applying to Health & Safety and prevention of accidents.

By usage in machines, the measuring unit should be used only when the machines fulfil the EC-machine guidelines.

3. Instrument Inspection

Instruments are inspected before shipping and sent out in perfect condition. Should the damage to a device be visible, we recommend a thorough inspection of the delivery packing. In case of damage, please inform your parcel service/forwarding agent immediately, since they are responsible for damages during transit.

Scope of supply:

- Plastic Level Switch model: NKP
- Operating instructions

4. Regulation Use

Model NKP devices are for use when monitoring liquid levels. The device should only be used with liquids that are compatible with the unit's materials of construction.

Level control is often accomplished with at least two level switches - one acting to sense the minimum level and the other for maximum level detection.

5. Operating Principle

The Plastic Level Switch NKP is designed for economical control of liquids in vessels. Many industrial applications can be realized with two different plastic versions each with three different mountings. The switch is remarkable for its maintenance-free design, small dimensions and reed contacts with high switch capacity. The switch is mounted on the side of the vessel. A hinged plastic float with a magnet floats up and down through the liquid level. The encapsulated reed contact is operated by the magnet. The switching function (N/O contact/N/C contact) is determined by the installation position. The switching function is reserved by simply rotating the switch through 180 °.

6. Mechanical Connection

The level switch should be mounted so that the float can move freely over its entire path without hitting the walls, floor or roof of the container. Avoid fitting the switch where agitators or inlet valves could expose it to excessive turbulence.

Make sure that the medium does not contain solids or ferrite particles, as they could collect on the float magnet and interfere with the switching operation. If the liquid does contain sediment or suspended matter, you must be sure they do not come into contact with the float system.



4 Nm of torque should be applied to the mounting nut for the NKP-6

Mount the switch so that it is easily accessible for installation and maintenance.

- Make sure that the allowed max. process pressures and service temperature for the device are not exceeded.
- Mount the unit on a horizontal axis.
- Check that the joints are tight, immediately after installation.

Mounting position

The mounting position of the level switch determines the contact operation.

NKP-6 (M16)

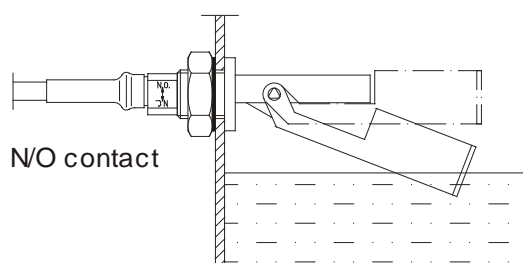
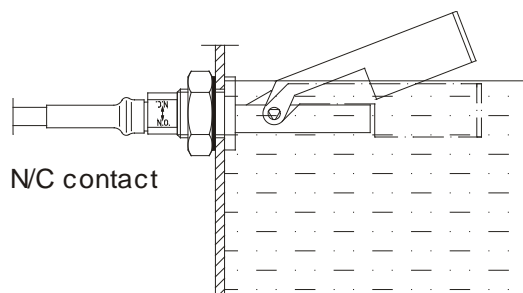

NKP-1 / NKP-2 (G1/2, 1/2 NPT)

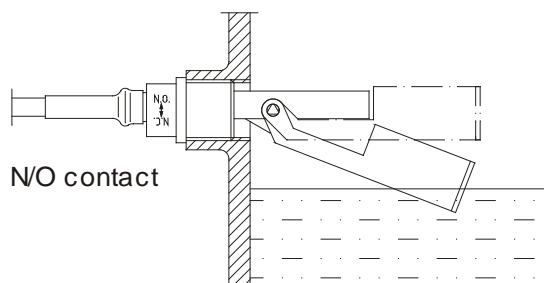
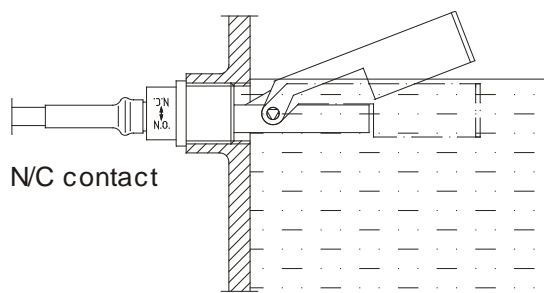

7. Electrical Connection



Attention! Be sure that the supply voltage of your system is the same as that specified on the device nameplate.

- Before proceeding, be sure that the electrical supply lines are de-energised.
- Attach the connection cable to your system, as indicated in the diagram below.
- The level switch is totally insulated; a protective grounding conductor is not required.

Conductor colour code

N/O contact

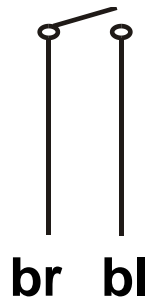

The device is ready for operation once you have connected your own process devices.

8. Technical Information

Switch housing:	NKP-14.., -24.., -64..: polypropylene NKP-15.., -25.., -65..: PVDF
Connections:	NKP-1..: G 1/2 NKP-2..: 1/2" NPT NKP-6..: M 16
Float:	NKP-14.., -24.., -64..: polypropylene NKP-15.., -25.., -65..: PVDF
Seal:	NKP-6401: NBR NKP-6501: FPM (FPM) alternative: EPDM
Counter nut:	NKP-6...: polypropylene
Max. temperature:	NKP-14.., NKP-24.., NKP-64...: 80 °C NKP-15.., NKP-25.., NKP-65...: 100 °C
Max. pressure:	10 bar
Installation position:	horizontal ($\pm 30^\circ$ from the horizontal plane)
Contact components:	N/O contact /N/C contact (depending on the Installation)
Electrical connection:	stranded cable AWG20, 2-core, PVC, 1 m
Switch capacity:	max. 230 V _{AC} /V _{DC} / max. 40 VA / 2 A
cCSAus:	0,17 A 230 V _{AC/DC} , 2A 20 V _{AC/DC} , max. 40 W
Contact resistance:	max. 80 mΩ
Min. electric strength:	400 V _{DC} / 1 s
Medium density:	NKP-14.., -24.., -64...: > 0.6 g/cm ³ NKP-15.., -25.., -65...: > 0.95 g/cm ³
Protection:	IP 68
Average electrical switch contact life (MTTF):	
at max. electrical load:	10 ⁵ switching operations
at half load (<10% max. load):	5*10 ⁷ switching operations
at low load (<10V/<1mA):	10 ⁸ switching operations

9. Order Codes

Order Details (Example: NKP-25011)

Model	Connection	Housing Material	Cable Length	Option
NKP-	1.. = G 1/2 2.. = 1/2" NPT 6.. = M16 Bulkhead	..401.. = Polypropylene ..501.. = PVDF	..1.. = 1 m ..1.6.. = 1.6 m ..3.. = 3 m ..6.. = 6 m ..10.. = 10 m ..Y ¹⁾ .. = Special Length	C = cCSAus

¹⁾ Please specify length in clear text (Only for cable lengths > 10 m)

10. Dimensions

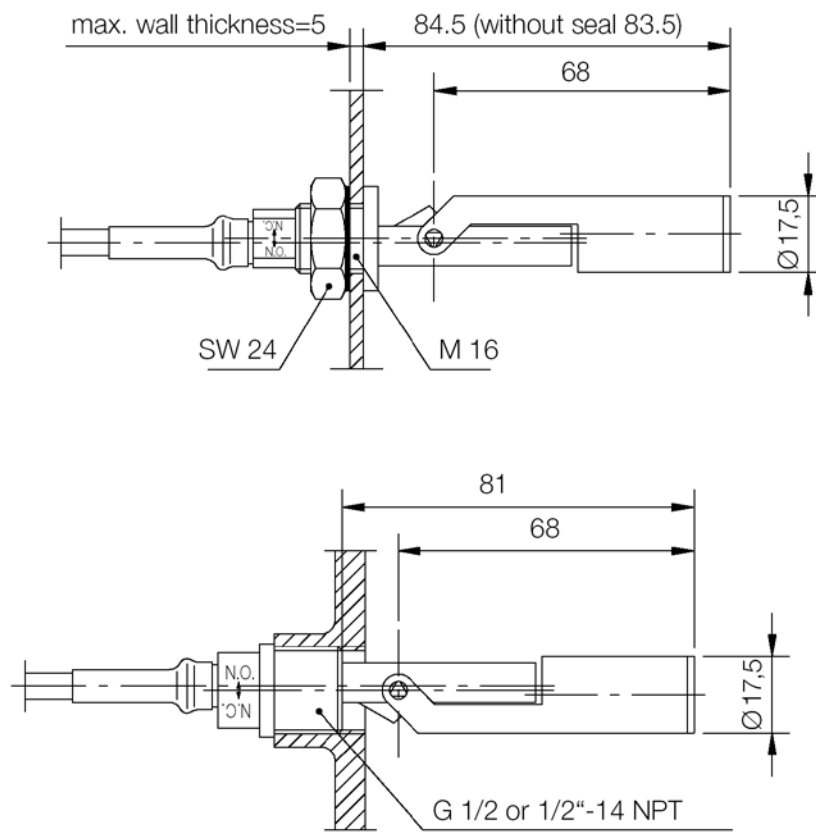

11. EU Declaration of Conformance

We, KOBOLD-Messring GmbH, Hofheim-Ts, Germany, declare under our sole responsibility that the product:

Plastic Level Switch model: NKP

to which this declaration relates is in conformity with the standards noted below:

EN 61010-1:2010

Safety requirements for electrical measuring, control and laboratory instruments

EN 60529:2014

Protection type through housing (IP code)

BS EN IEC 63000:2018

Technical documentation for the assessment of electrical and electronic products with respect to the restriction of hazardous substances.

Also, the following EC guidelines are fulfilled:

2014/35EU

Low voltage guideline

2011/65/EU

RoHS (category 9)

2015/863/EU

Delegated Directive (RoHS III)



H. Peters
General Manager

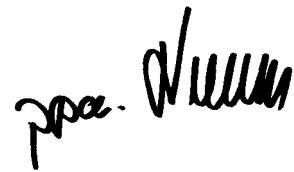

M. Wenzel
Proxy Holder

Hofheim, 01 Febr.2021

12. UK Declaration of Conformity

We, KOBOLD Messring GmbH, Hofheim-Ts, Germany, declare under our sole responsibility that the product:

Plastic Level Switch model: NKP

to which this declaration relates is in conformity with the standards noted below:

BS EN 61010-1:2010+A1:2019

Safety requirements for electrical equipment for measurement, control, and laboratory use. General requirements

BS EN 60529:1992+A2:2013

Degrees of protection provided by enclosures (IP Code)

BS EN IEC 63000:2018

Technical documentation for the assessment of electrical and electronic products with respect to the restriction of hazardous substances.

Also, the following UK guidelines are fulfilled:

S.I. 2016/1101

Electrical Equipment (Safety) Regulations 2016

S.I. 2012/3032

The Restriction of the Use of Certain Hazardous Substances in Electrical and Electronic Equipment Regulations 2012

Hofheim, 01 Febr. 2021



H. Peters
General Manager



M. Wenzel
Proxy Holder