



AM-FOG Portable FOG Probe



Installation and Operation Manual

Contents

1. Introduction.....	3
2. Safety.....	3
3. Specifications.....	4
4. Principle of Operation	4
5. What comes with the AM-FOG Probe.....	5
6. Operating the AM-FOG Probe	6
6.1 Downloading the AM-FOG Connect App.....	6
6.2 Getting Started	7
6.3 Configuring the Probe.....	8
6.4 Calibration	10
7. Taking a Measurement.....	11
7.1 Basic Measurement with the Measure Screen.....	11
7.2 Diagnostics.....	12
7.3 Saving Logs.....	12
8. Maintenance.....	13
8. Troubleshooting.....	14
9. Disposal.....	15
10. Accessories and Spare Parts	15
11. Dimensions	16
12. Contact.....	17

1. Introduction

The AM-FOG Probe is the first digital analyzer developed to replace core samplers (e.g., Sludge Judge®, Dipstick Pro®). The probe is portable, robust, customizable and inexpensive. It measures the level of fats, oils, and grease (FOG) in grease interceptors quickly, accurately, and as cleanly as possible. It records the results of a measurement for verifiable record keeping. The AM-FOG probe is a game changer for inspectors, haulers, and food service establishment (FSE) workers who need to know the status of a grease interceptor quickly and cleanly.

The AM-FOG Probe is the result of five years of intense product development. Other FOG analyzers have relied on conductance, which suffers from fouling or ultrasonic transducers, which also are impacted by fouling and are very expensive to build. Because it is based on measuring the electrical properties of the surrounding medium there are no moving parts or expensive transducers. The coating of the probe changes the reading very slightly, so fouling is not a major problem. The result is a probe that can withstand the extreme physical and chemical environment of a grease interceptor. There are other FOG analyzers that use capacitance, but the AM-FOG uses several ingenious innovations which make the probe robust, inexpensive, and extremely easy to use.

The length of the AM-FOG probe can be made to any multiple of 8 inches, up to 64", so that it can be configured for any grease interceptor except for the very largest gravity interceptors. The embedded firmware senses the correct length and customizes the user interface on the free downloadable app (AM-FOG on Google Play or Apple App stores) and works for any probe.

2. Safety



WARNING

Electrical hazard

Do not open the controller on top of the probe unless you have electrical training and you have read the instruction manual. The controller contains a 3.6 V battery and a printed circuit board that can be easily damaged with improper handling.



NOTICE

The probe should not be submerged.

The probe should not be submerged any higher than the top of the sensing tube. The probe is designed to be robust, but it can be damaged from a fall. Gently place it on its side when the device is not in use. During calibration, it is recommended to maintain contact with the probe and calibration case to ensure that it does not tip, even when using the stand.

3. Specifications

FOG Model	AM FOG	AM FOG	AM FOG	AM FOG	AM FOG	AM FOG	AM FOG
	16	24	32	40	48	56	64

Detection	Water, FOG, air
Resolution	2.5 cm (1")
Measurement Length	16" to 64" in 8" increments
Alarm Indicator	Default—25% Rule
Calibration	Two points: Water and Air.
Wetted Materials	PVC, PLA
Ingress	IP65
Cleaning	Integrated wiper, optional disinfection wipes
Transportation	Carrying case (PVC). Doubles as water container for calibration
Extension	Acme thread. Accepts most extension poles

Extension	Optional
Wireless transmission	Bluetooth Low Energy (BLE)
Transmission Range	5-10 m
User Interface	App for Android and iOS
Operation Modes	Calibrate, Run, Configuration
Battery	Lithium Metal: 3.6 V, 950 mAh
Temperature	-10 to 60 °C
pH Range	2 to 12
Status Indicator	LED
Cleaning	Squeegee integrated into carrying case.

4. Principle of Operation

The AM-FOG Probe does not actually measure air, water, or FOG. It's important to understand this point so there is no misunderstanding about what the probe is actually doing. It cannot actually distinguish between air, water, or FOG. Instead, the AM-FOG Probe works by measuring the capacitance of the surrounding medium.

Capacitance is related to an electrical property called the dielectric constant. Materials that hold a large charge, such as air, have a high dielectric constant. Those that don't, such as water, have a low dielectric constant. The dielectric constant of FOG is lower than air but higher than water.

The AM-FOG Probe uses electrodes whose electric fields extend several centimeters into the medium to measure capacitance. The probe consists of a number (1 to 8) of 8" sensor boards attached in series, with each board containing 8 capacitance sensing elements located at 1" intervals. The probe length can be anywhere from 16" to 64", with 1" resolution, regardless of size. The probe can effectively measure FOG in any type of grease interceptor regardless of type (e.g., hydromechanical, gravity, or grease removal device).

Firmware inside the probe communicates via Low Energy Bluetooth (BLE) to an app on a smart phone or tablet. The app is free and available for both Android and iOS (iPhone) devices. Configuration, calibration, and measurement are all done on the app. Search for AM-FOG on your Google Play or Apple App stores.

The value of the capacitance that the probe reads is in units of frequency (Hz). The process of calibration accomplishes two goals:

1. It minimizes the differences between sensors and improves the precision of the measurement.
2. It resets the measurement range from Hz to an arbitrary scale of 0 to 10,000, in which 0 is the value for tap water and 10,000 is the value for water.

An algorithm has been developed to convert the raw frequency measurements into a more manageable working range. Typical capacitance values fall into the following algorithmically calculated ranges:

AM-FOG Analyzer Default Capacitance Ranges	
Air	8,000 – 11,000
FOG	3,000 – 8,000
Water/Sludge	0 – 3,000

To ensure accurate readings during inspection the AM-FOG Probe needs to be calibrated periodically. The calibration process is necessary for both air and water and the process is managed through the app. You cannot “over calibrate” a probe so repeating the process multiple times will only enhance the accuracy of its measurements.

5. What comes with the AM-FOG Probe

The AM-FOG probe is a self-contained unit and has no accessories that are necessary for operation. The only other component needed is the free app loaded onto your smart phone. The handle of the probe will enable you to immerse the probe in the interceptor.



The probe comes with a 3” diameter PVC carrying case—shown on the left. The carrying case doubles as a container for calibrating the probe in water. A stand is included to enable the probe to be free-standing, but it is not meant to be used unattended for periods of time.

If you need to access an interceptor that is buried, there is a recessed ACME female thread in the controller. Any extension pole that has a male ACME threaded end will screw into the controller, e.g., a painter’s extension pole.

To wipe down the probe, it comes equipped with a squeegee with a handle and a built-in rubber wiper. Just pull the handle down the length of the probe to remove caked-on FOG for quick and easy cleanup. Finish up by wiping the probe down with a wet wipe and paper towel.



6. Operating the AM-FOG Probe

6.1 Downloading the AM-FOG Connect App

The interface to the probe is through an app on an Android or iOS (Apple) phone. The app is free. We are constantly adding useful features so keep checking the app store for the latest version.

For an Android phone go to the [Play Store](#) and look for [AM-FOG](#). For an iPhone go to the [App Store](#).



The app does NOT connect to the internet. Therefore, it collects zero information from you to send to us or anyone else so you can rest assured that there is no risk to the privacy of you or your organization in downloading and using the app.

6.2 Getting Started

1. Turn on the probe by pressing the power button. The green LED surrounding it will blink. If nothing happens then it's possible that the battery came loose during shipment. If you open the cover of the head enclosure you will see the battery and its connector.
2. Launch the app. Just press the **AM-FOG** app icon.
3. The first time the app is used you will be prompted to allow the use of **Bluetooth**. Click "ok" to allow the app to talk to the probe through a Bluetooth connection.
4. Press the **SCAN** button on the bottom of the initial screen. It will search for the Bluetooth signal from the probe.
5. When the app finds the probe, a new screen will display prompting the user to **Select the device** to connect to.
6. If there is more than one probe powered on, the screen will list all those probes, but with the same description for each. This can make picking the "right" probe more difficult, therefore we recommend only turning on the probe you want to connect to.
7. Upon successful connection the **Configuration** screen will appear.



6.3 Configuring the Probe

Successful connection with the probe automatically brings up the **Configuration** screen. There are six functions in the app: Measure, Diagnostics, Calibrate, Configuration, View Logs, and Advanced Settings. They are accessed by clicking on the menu icon in the upper left corner (three horizontal bars).

The top of the Configuration screen allows you to personalize the probe and the location you are sampling. The first time you connect the app to a probe you will want to change the **Probe Description** and enter the serial number for the probe (printed on the label on top of the probe housing). The information entered will be saved for each probe you link to so that each will be identifiable by the app.

The **Location** information is intended to be set by the user according to user preference. All three fields are just text fields in which a limited amount of information can be saved. It may be useful to capture the name of the inspector, the name of the FSE, the location of the grease interceptor onsite, or any other information the user deems important.

The bottom of the Configuration screen contains the **Set Points** for the probe. The factory default settings for the probe may or may not be accurate for your specific location. Readings may be affected by elevations, ambient temperatures, humidity, and so on. Therefore, you may need to adjust the ranges to improve accuracy of measurements for your area.

Before adjusting the set points, you should calibrate the probe for air and water first. This will reset all of the values in the firmware for the probe for your area. Once calibrated, you can check to see what the effective ranges for air and water are and this will allow you to determine the effective range for FOG.

The “typical” ranges for air, FOG, and water are as follows:

Scaled Value	Component	Color
8000 - 11000	Air	Light Blue
3000 to 8000	FOG	Yellow
<3000	Water	Dark Blue
N/A	Spacer*	Grey

*Note, the bottom one-inch inside the probe contains a spacer that absorbs the weight and supports the column of sensors. There is no sensor in this space.

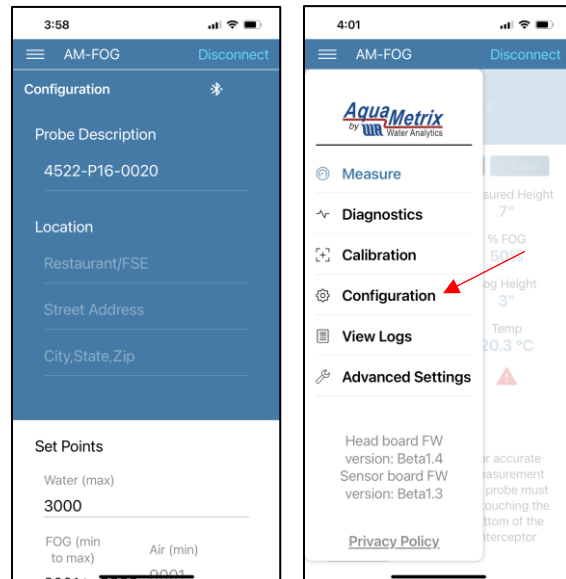

To validate the set points, go to the [Menu](#) and click on [Diagnostics](#). This will take you to the Diagnostics screen. Here you will see five columns:

Sensor = each sensor inside the probe numbered from the top down

Height (in) = the total height of the probe as measured from the bottom up, beginning with 2” at the final sensor, since there is no sensor in the bottom 1” of the probe

Scaled Frequency = the algorithmic calculations for Air, FOG, and Water

Frequency (comp.) = the value of the capacitance that the probe reads in units of frequency (Hz)

Temp (°C) = ambient temperature around the probe in the marked sections of sensors; affected by surroundings and will change for those sensors affected when submersed in an interceptor.

Sensor	Height (in)	Scaled Frequency	Frequency (Comp.)	Temp. (°C)
1	25	9,994	79,301	20.0
2	24	10,161	76,605	
3	23	10,156	76,333	
4	22	10,180	76,381	
5	21	10,207	75,861	
6	20	10,199	73,509	
7	19	10,198	75,261	
8	18	10,196	74,093	
9	17	10,196	74,259	20.2
10	16	10,164	75,995	
11	15	10,147	75,963	
12	14	10,109	76,155	
13	13	10,089	76,307	
14	12	10,089	72,907	
15	11	10,078	75,331	
16	10	10,026	74,739	
17	9	9,925	69,888	19.11
18	8	9,929	74,272	
19	7	9,931	73,944	
20	6	9,772	74,584	
21	5	9,893	74,568	
22	4	9,929	72,016	
23	3	9,888	74,976	
24	2	9,726	74,816	

For the purposes of checking the set point values, hold the probe in the [air](#) and make note of the **Scaled Frequency** range of values displayed (image to the left above). In the image provided you can see the range is from 9,700 on the lower end to over 10,000 on the upper end of the range. The lower end can be closer to 9,000 and the upper end over 11,000, routinely.

Once the air values have been verified take a 5-gallon bucket and fill it “mostly” full of [water](#) from the tap. Dip the probe in and rest it on the bottom of the bucket for a minute or so (longer is fine). Again, make note of the **Scaled Frequency** range of values displayed (image to the right above). In the image provided you can see the range is from -500 on the lower end to 173 on the upper end. The lower end may or may not be below zero and the upper end can be as high as 2,000, routinely. In some cases, the upper range can be as high as 2,500 or even a bit higher.

These range checks give us the upper and lower values for Air and Water. FOG falls between these ranges. To change the set points, start with water. Touch the value shown Water (max). and it will allow you to change it. Set the upper limit for water, which is by default the lower limit for FOG. Thus, we want to set the value at a safe lower limit for FOG. 3,000 works well, typically, and is the default value.

Next touch the value range for FOG (min to max), which allows you to change the upper limit for FOG, which corresponds to the lower limit for air. The probe is preset at 8,000, however, that value may be too low for many areas. If the lower limit for air in your area is consistently over 9,000, you may want to change this value to 9,000.

Finally, the only thing effected by changing these values is which colors apply to the ranges you want. Color coding

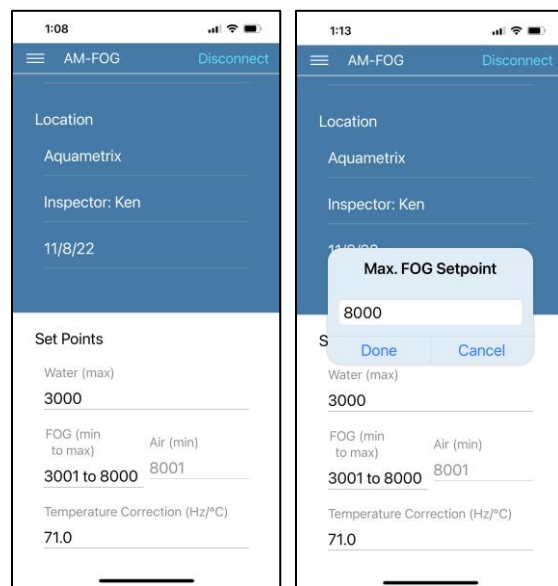

is offered to present the Air, FOG, and Water levels as a visual aide. You can change these as often as necessary to ensure the most accurate visual presentation.

6.4 Calibration

As with any sensor, two points are required to calibrate the FOG probe. The firmware converts the frequency values from the sensors into arbitrary values called **Scaled Frequency**, such that 0 represents the lowest scaled frequency value (water) and 10,000 represents the highest scaled frequency value (air).

Calibrating the probe in **Water** requires a container at least as deep as the probe. The 3" diameter carrying case doubles as a reservoir for water calibration. Simply fill the carrying case with water and submerge the probe. A larger/wider container may give slightly better accuracy.

During **Air** calibration, hanging or holding the probe in air is sufficient. Keep the probe at least 2" away from any surface.

To conduct a calibration of the probe, press the menu icon in the top left and bring up the menu screen and select **Calibration**.

Follow these instructions for **Water**:

1. Immerse the probe in a bath of water up to the top of the PVC pipe. (Do NOT immerse the head unit.) The carrying case that comes with the probe can be filled with water for convenient calibration.
2. Allow about a minute for the probe to equilibrate in water.
3. Press the **Water Calibration** button.
4. When the Alert window appears select **Calibrate**. This starts the one-minute calibration.
5. The **Calibration** screen will return.

Follow these instructions for **Air**:

1. Hang the probe in the air for at least one minute to let the probe equilibrate.
2. Press the **Air Calibration** button.
3. When the **Alert** window appears select **Calibrate**. This starts the one-minute calibration.
4. The **Calibration** screen will return.

Note that the Calibration screen reports the results of the calibration: the date of both calibrations and the slope and the intercept of the graph that converts frequency values to the calibrated range of 0 to 10,000.

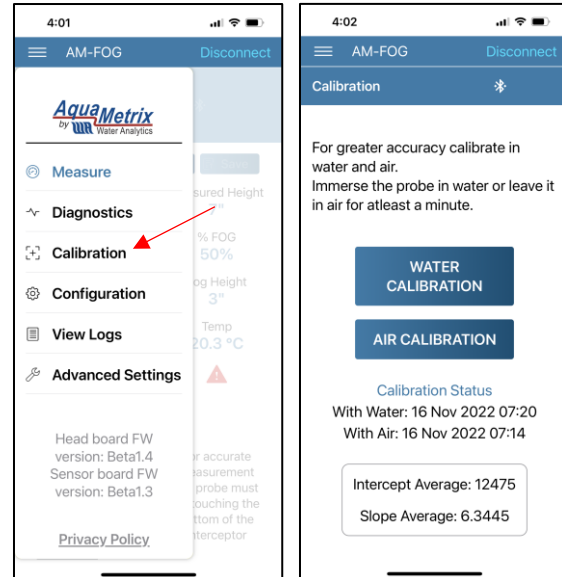

7. Taking a Measurement

7.1 Basic Measurement with the Measure Screen

To conduct a measurement of the FOG layer in a grease interceptor, press the menu icon in the top left and bring up the menu screen and select **Measure**. The primary screen that you will see is the Measure screen. This is a simple bar graph that is color coded as follows:

Component	Color
Air	Light Blue
FOG	Yellow
Water	Dark Blue
Spacer*	Grey

When you are ready, dip the probe into the grease interceptor, straight down (as little angle as possible). Do not submerge the head assembly of the probe, which is where the electronic components are located.

If the probe is able to touch the bottom of the grease interceptor, you will get an accurate measurement for the percentage of FOG and the height of the FOG layer.

It's important to let the probe sit in the grease interceptor for a minute or so because when it is first submerged it will drag some FOG down into the water area, which needs time to resettle into the FOG layer.

The app calculates the total height of the static water and assumes that the probe is touching the bottom of the grease interceptor in the calculation. If the probe is not touching the bottom, then disregard the calculated percentage as it will not be accurate. A red triangle appears if more than 25% of the volume of the interceptor is occupied by FOG, but again, this will not be accurate if the probe is not actually touching the bottom of the grease interceptor.

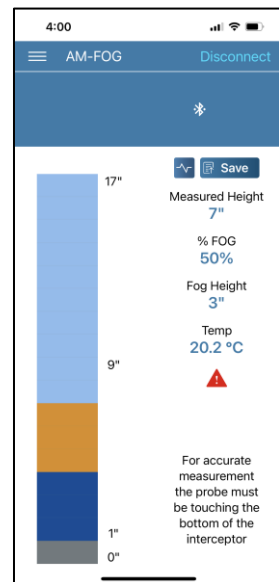
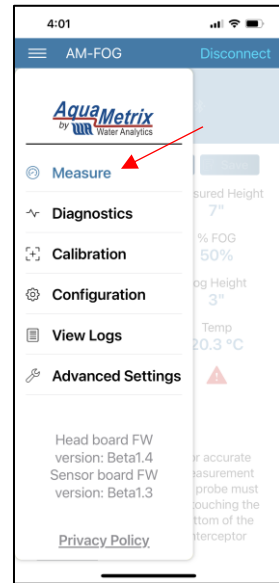

7.2 Diagnostics

The Measure screen displays the data captured during an inspection as a simple graph, while the Diagnostics screen provides the actual data captured during an inspection. To access the **Diagnostics** screen, press the menu icon in the top left and bring up the menu screen and select Diagnostics.

The same color coding is used in the Diagnostics screen to make it easier to see the different layers of Air, FOG, and Water.

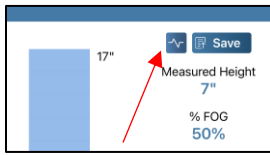

Shortcut to Diagnostics Screen

The Diagnostics screen is also reachable by clicking on the waveform icon that sits next to the Save icon on the Measure screen, just above the “Measured Height” data.

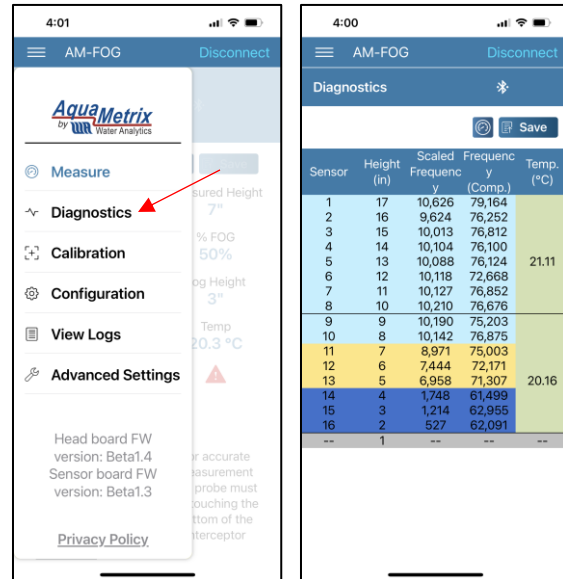

7.3 Saving Logs

The **Measure** screen is presented in a simple graphical manner to make presenting the condition of the grease interceptor to the FSE easy and easy to understand. A screen shot of the measurement can be saved as part of the record for the inspection.

There is a “save” button to the right and just above the “measured height” and percentage calculations. This will create a Log that is saved to the smart phone or tablet. You can access these logs by pressing the Menu icon and selecting View Logs.

The **View Logs** screen shows all of the logs that have been saved to the device. You can then select the log you wish to view from this list.

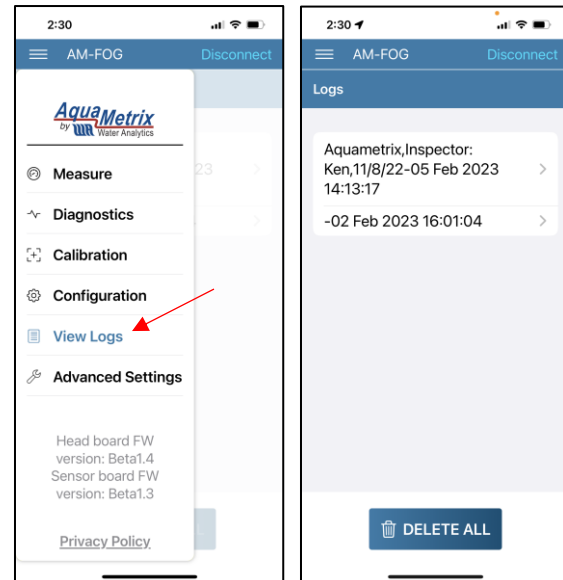

The Log you select to view will bring up a separate window like the screen shot image here (left). It will contain the same information that is displayed on the Diagnostics screen along with the “measured height” and percentages information that is shown on the Measure screen.

Each Log records the GPS location where it was saved. Clicking on the link will open your maps program showing the exact location of the inspection by latitude and longitude. This makes it easy to connect a Log to a given record for an FSE.

At the top right of the app is the upload icon, which looks like this:

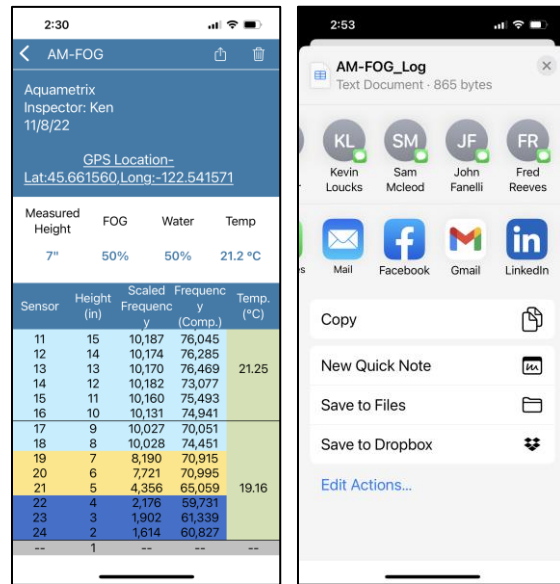

Clicking the upload icon brings up a separate window, shown above (right), which allows you to text the Log, email it, or even share it to social media. This is your permanent Log for the inspection so save it as appropriate with the records for the FSE.

8. Maintenance

The maintenance is simple. After testing simply slide the “squeegee” wiper down the probe to remove any residual fats, oils or greases from the testing. The design of the probe and cleaning process is intended to keep the user clean. It is recommended to also use on both the probe and the “squeegee” a sanitizing wipe after usage or it can be cleaned with a hot water rise it mild soap or vinegar.



NOTICE

Danger of damage to the instrument due to inappropriate cleaning agents!

The head enclosure and probe are made of PVC. This material can be sensitive to some organic solvents, If liquids enter the head enclosure they can damage the instrument.

1. Use only water and a mild detergent to clean the housing.
2. Wipe off any spills immediately.



WARNING

The battery powering this probe is considered a consumable item. Please reference section 7 on disposal. The Battery in the AM FOG is a Lithium Metal Battery and should only be disposed of according to local regulations. Shipping of this type of battery is prohibited by air in the US. 

When replacing the battery, to reduce the risk of injury, the user must read the instruction manual prior to use. Use only with battery from Water Analytics. Always use proper PPE. To protect the device, the probe must be stored properly, and the head enclosure should not be submerged. If this has occurred, precautions should be taken by a trained professional to remove and replace the lithium metal battery.

The replacement of the battery is simply done by removing the 4 screws of the head enclosure and disconnecting the snap connector of the battery. Then the battery can be removed by hand or with the appropriate tool. The new battery is simply inserted into the battery holder and the snap connector can then be engaged (Note: there should only be one way to connect, but if the female mating snap connector is missing or broken, please contact the Water analytics team for further troubleshooting).

8. Troubleshooting

- 1. You press the power button, but the LED does not blink and the probe does not appear in the app.**
Either the battery is dead or it came loose during shipment. If you open the cover of the head enclosure you will see the battery and its connector. If the battery is properly connected then it needs to be replaced.
- 2. The probe connects to the app, but the Measure and Diagnostics screens fail to show any sensor values.**
Communication between the sensors and the controller has been lost. The cause may be as simple as the ribbon cable connecting the controller board disconnecting from one of the two ends or it could be a failure of one or more of the sensor circuit boards. A snap connector may have become loose during shipment.
- 3. The FOG and water levels shown on the Measure screen don't look correct or don't agree with a core sampler.**
The probe's calibration might be obsolete and need to be updated. A simple test to verify this is to simply hold the probe in air and check the scaled values in the Diagnostics screen. The values should be between 9000 and 11,000. Alternatively, you can insert the probe into the case filled with water. Those values should be between -1000 and 1000. If not, then calibrate the probe in both air and water. (If you're checking the probe output in water it only takes an extra minute to calibrate it in water.)

If the values in the Diagnostics screen are reasonable then the color coding does not reflect the actual composition of the trap. For instance, the app might show 1" of FOG and you are certain the FOG layer is thicker. That can happen you set the FOG range in the Configuration screen to be 3000 to 8000 but the Diagnostics screen shows a value of, say, 2800. If you were to change

the FOG range to 2000 to 8000 then the app would show 2” of FOG. Always let the **Diagnostics** screen be your guide.

4. The Measure and Diagnostics screens look unusual when you first insert the probe and then starts to change in the direction you expected.

At some grease interceptors, the viscosity of the FOG may be such that the FOG layer may temporarily adhere to the probe during insertion. In these cases, leave the probe inserted for a few minutes to ensure that the FOG has settled. This will occur in colder environments, especially as the FOG layer approaches freezing.

5. If the Connecting icon continues ad infinitum



The probe timed out. Just restart the connection process. If the Connecting icon continues to spin, then the controller board in the head of the probe has lost contact with the sensor boards in the probe. The likely cause is that the ribbon cable that connects the controller board to the top sensor board has disconnected.

If problems persist, contact us at support@wateranalytics.net or call us at 978-749-994.

9. Disposal

In accordance with local regulations, please dispose of this product at specified locations for electrical and electronic equipment. Please contact the local government/authority or party responsible from which you purchased this device. Should this device be passed on to other parties (for private or professional use), the content of this regulation must also be related.

10. Accessories and Spare Parts

Part Number	Description
C1-FOG-POLE (AM-FOG-POLE)	Extension pole with an Acme thread
A50-18	Replacement Battery (Lithium Metal: 3.6 V, 950 mAh) (Ground ship only)
C1-FOG-WIPER (AM-FOG-WIPER)	Squeegee Wiper
A29-362	Replacement Stand
C1-FOG-CASE-24	Calibration case suitable for AM-FOG 16,24
C1-FOG-CASE-40	Calibration case suitable for AM-FOG 32,40
C1-FOG-CASE-54	Calibration case suitable for AM-FOG 48,54
C1-FOG-CASE-64	Calibration case suitable for AM-FOG 64

11. Dimensions

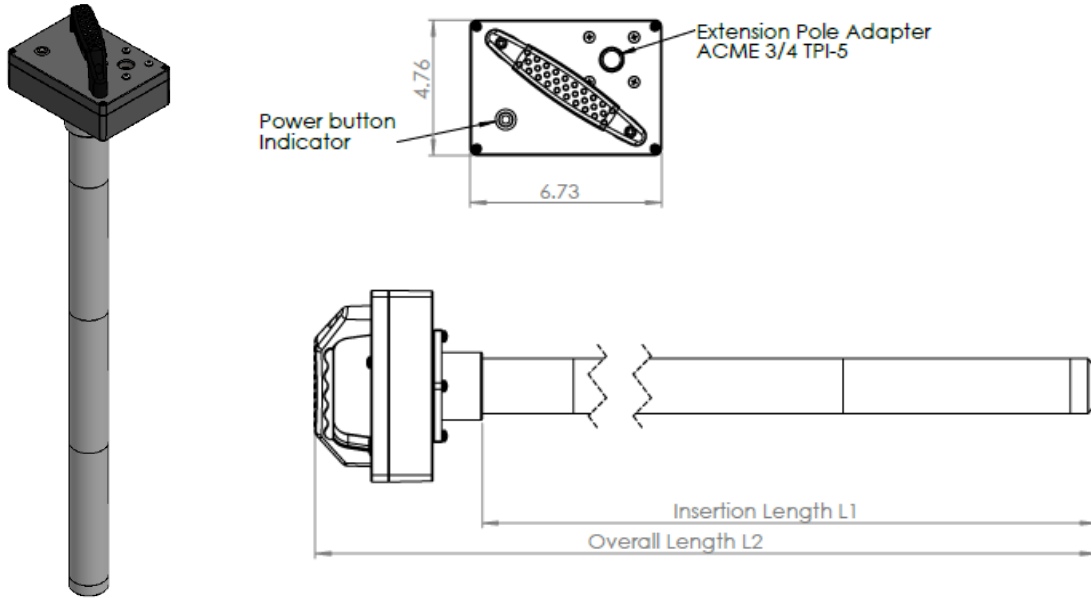

Sensor model	Insertion Length L1 (in)	Overall Length L2 (in)
AM-FOG-P-16	18.7	25.7
AM-FOG-P-24	26.7	33.7
AM-FOG-P-32	34.7	41.7
AM-FOG-P-40	42.7	49.7
AM-FOG-P-48	50.7	57.7
AM-FOG-P-56	58.7	65.7
AM-FOG-P-64	66.7	73.7

12. Contact

Please contact us at support@wateranalytics.net or call us at 978-749-9949



100 School Street
Andover, MA 01810
978-749-9949
www.WaterAnalytics.net