



# MONARCH INSTRUMENT

*Instruction Manual*

 **IllumiNova<sup>®</sup>**

Fixed Mount LED Stroboscope



15 Columbia Drive

Amherst, NH 03031 USA

Phone: (603) 883-3390 • Fax: (603) 886-3300

E-mail: [support@monarchinstrument.com](mailto:support@monarchinstrument.com)

Website: [www.monarchinstrument.com](http://www.monarchinstrument.com)



# SAFEGUARDS AND PRECAUTIONS



- Read and follow all instructions in this manual carefully, and retain this manual for future reference.
- The contents of this manual are correct at the time of issue. The contents may change at any time without prior notification. This is due to continuous developments to the stroboscope and its functionality.
- Do not use this instrument in any manner inconsistent with these operating instructions or under any conditions that exceed the environmental specifications stated.
- Certain strobe frequencies can trigger epileptic seizures in those prone to that type of attack.

## OPTICAL RADIATION



- Users should not stare directly at the light source.
- Intense light sources have a high secondary blinding effect. A temporary reduction in visual acuity and afterimages can occur, leading to irritation, annoyance, visual impairment, and even accidents - depending on the situation.
- Always consider the use of light filtering and darkening protective eye wear and be fully aware of surrounding setups when viewing intense light sources to minimize or eliminate such risks to avoid accidents related to temporary blindness.
- Prolonged exposure to the light can cause headaches in some people.

## HIGH VOLTAGE



- Parts inside the strobe carry the risk of electric shock. Contact with live electrical components can cause shock, serious injury, or death from electrocution. Use a properly grounded power source.
- There are no user serviceable parts in this instrument. Refer service to a qualified technician.
- Objects viewed with this product may appear to be stationary when in fact they are moving at high speeds. Always keep a safe distance from moving machinery and do not touch the target.
- Do not allow cables extending from unit to come into contact with rotating machinery, as serious damage to the equipment, or severe personal injury or death may occur as a result.
- This instrument may not be safe for use in certain hazardous environments, and serious personal injury or death could occur as a result of improper use. Please refer to your facility's safety program for proper precautions.



In order to comply with EU Directive 2012/19/EU on Waste Electrical and Electronic Equipment (WEEE): This product may contain material which could be hazardous to human health and the environment. **DO NOT DISPOSE** of this product as unsorted municipal waste. This product needs to be **RECYCLED** in accordance with local regulations, contact your local authorities for more information. This product may be returnable to your distributor for recycling - contact the distributor for details.

---

Monarch Instrument's Limited Warranty applies.  
See [www.monarchinstrument.com](http://www.monarchinstrument.com) for details.

Warranty Registration and Extended Warranty Coverage information is available online at [www.monarchinstrument.com](http://www.monarchinstrument.com).

---

# Table of Contents

Congratulations on your purchase of the latest in stroboscopic inspection technology! .....	1
1.0 INTRODUCTION.....	2
2.0 USER INTERFACE .....	2
3.0 GETTING STARTED.....	3
3.1 Installation.....	3
3.2 Powering the Unit.....	3
3.3 Input/Output Connections.....	3
3.3.1 Input.....	3
3.3.2 Output.....	3
4.0 MODES OF OPERATION.....	4
4.1 Internal Mode.....	4
4.1.1 Rotary Knob .....	4
4.1.2 Arrow Buttons.....	4
4.1.3 Using the Numeric Touchscreen Keypad.....	4
4.1.4 Doubling or Halving the Flash Rate.....	4
4.2 External Mode .....	4
4.3 ON Mode.....	5
5.0 MENU SETTINGS .....	5
5.1 BRIGHTNESS - BRITE .....	5
5.2 WIDTH/CLARITY - WIDTH .....	5
5.2.1 Degree of Rotation Adjustment - DEGS .....	5
5.2.2 Percent of Duty Cycle Adjustment - PCNT .....	5
5.2.3 Time Pulse Duration Adjustment - TIME .....	6
5.3 Mode of Operation - MODE .....	6
5.4 JOG/DELAY.....	6
5.4.1 NONE.....	6
5.4.2 PHASE.....	6
5.4.3 TIME .....	6
5.4.4 VRPM (External Mode ONLY) .....	6
5.5 MEMORY - MEMORY (Internal Mode ONLY).....	7
5.5.1 Recall Memory.....	7
5.5.2 Save Memory.....	7
5.6 MISCELLANEOUS - MISC .....	7
5.6.1 Decimal Point - DECPNT .....	7
5.6.2 Scale - SCALE (External Mode ONLY) .....	7
5.6.3 Standby - STDBY .....	8
5.6.4 Duty Cycle - DUTY .....	8

5.6.5 Prescale - PRESC (External Mode ONLY) .....	8
5.6.6 Engineering Units - UNITS .....	8
5.6.7 Input Pulse Active Edge - INPUT .....	8
5.6.8 Output Pulse Polarity - OUTP .....	9
5.6.9 Backlight - BKLT .....	9
6.0 STROBE CLARITY .....	9
6.1 Calculating Blur .....	9
6.2 Degrees of Rotation .....	10
6.3 Percent of Duty Cycle .....	10
6.4 Time Pulse Duration .....	10
7.0 STROBE DELAY .....	10
7.1 Internal Phase/Time Delay (JOG) .....	10
7.2 External Delay .....	10
7.2.2 External Time Delay .....	11
7.2.3 External Virtual RPM (AUTO) .....	11
8.0 FAULT DETECTION .....	11
9.0 MAINTENANCE .....	11
10.0 SPECIFICATIONS .....	12
10.1 Compliance .....	12
11.0 SENSORS AND ACCESSORIES .....	13

# Congratulations on your purchase of the latest in stroboscopic inspection technology!

The illumiNova® series of fixed mount stroboscopes are available in a variety of configurations and sizes to address a diverse set of field applications where they are used. In addition to clear crisp stroboscopic stop-motion inspection for web printing and converting applications, which Monarch Instrument is well known for, you will also find our illumiNova working along with camera vision systems providing the precise illumination techniques required for line scan and area scan systems. The illumiNova is available with LED array lengths from six inches [15 cm] to eight feet [250 cm]. Select from three lens options to provide the optimal illumination area required for your specific application.

Common applications include:

- Printing and converting inspection
- Paper processing and finishing
- Textile process manufacturing
- Pharmaceutical process manufacturing
- Vibration test, analysis and validation systems
- Scientific motion studies
- Blown film and composite polymer inspections
- Cold rolled metal fabrication and coating industry
- Research and development sciences
- Amusements and special effects
- Specialized engineering applications in: high-speed robotics, shot peening, and fast servo tool systems



illumiNova is also available with ultraviolet LEDs for inspection of invisible inks, security elements and optical brighteners. We have been designing and manufacturing stroboscopic inspection systems for over 30 years.

As with our Nova-Pro® Portable Stroboscopes, the illumiNova has an incredibly accurate on board digital controller allowing complete stand-alone functionality or, you can utilize the external input feature to synchronize the flash output rate to your system's existing trigger pulse signal. illumiNova also has advanced features like slow-motion, time and phase delay giving you optimal process viewing flexibility.

This manual provides information for the typical user set up and operation of the illumiNova. This product interfaces with many standard sensing devices used to trigger the strobe including Magnetic, LED, Infrared, Laser, Inductive, Proximity, Hall, and others. Monarch Instrument manufactures a full range of remote sensors for use with all of our strobes and we welcome you to consider purchasing any of these for simple plug-and-play setup. Please contact Monarch so we can help you select the proper device for your specific application.



Magnetic Sensor  
(shown with Amplifier)



Proximity Sensor



High-Temp Optical Sensor



Laser Sensor

## 1.0 INTRODUCTION

The illumiNova is a full-featured permanently mounted high-intensity LED strobe. It is available with LED arrays in varying lengths from 6 inches [152 mm] to 8 feet [2400 mm] and three different lens options for specific light coverage.



The strobe has a large backlit LCD with a touchscreen keypad, multiple buttons and a rotary knob allowing the user to easily set flash rates, flash duration, brightness levels, and many other advanced features including jog or delay functions. An optional remote controller plugs into the RJ-45 jack extending these controls up to 100 feet [30 m].

**Note:** This is NOT an Ethernet port.

An input jack allows external sources such as sensors, generators or other strobes to trigger the unit. The output jack provides pulses in sync with the flash and may be used to trigger other strobes or systems as needed.

## 2.0 USER INTERFACE

There are four (4) arrow buttons, two (2) function buttons, a rotary knob, and touchscreen keypad for user interaction.

Their functions are:

 The four arrow buttons are used to navigate through menus and adjust values on the display. Clockwise from the top, the function of each button is **UP, RIGHT, DOWN, LEFT**.

When adjusting a displayed value, the ◀ and ▶ buttons select the digit to adjust and the ▲ and ▼ buttons increment and decrement the value.



**MENU or SELECT** button — This button is used to invoke special functions and enter the menu system. It is also used to select the displayed value in any options menu setting.



**ESCAPE or LED ON/OFF** button — This button functions as the Escape button from any point in the menus. It is also used to turn the LEDs on or off from the home screen but keeping the unit on for user interaction.



The rotary knob can be used to increment or decrement the flash rate and other display values or scroll through the menus. It supplements the UP ▲ or DOWN ▼ buttons.

The LCD shown to the right shows all segments for demonstration purposes. The display is capable of showing six numeric and five alphanumeric characters. The bottom section of the display is a capacitive touchscreen. The segment functions will be described in the applicable sections.



**STATUS LED** — Red in Standby Mode (LEDs not flashing) and green in the Run Mode (LEDs flashing). A red LED may also indicate an internal fault condition.

## MENU NAVIGATION BUTTONS



Active  
SETTING



ESCAPE  
button or  
LED ON/OFF



MENU or  
SELECT  
button



UP



DOWN



LEFT



RIGHT

Use Rotary Knob or Arrow Buttons to adjust

## 3.0 GETTING STARTED

### 3.1 Installation

Refer to illumiNova Installation Manual for more information - Part Number: 1071-4255-2XX (where XX = Revision).

### 3.2 Powering the Unit

To turn the unit on, press the **POWER SWITCH** on the side to the right of the control panel. When the **I** is depressed, the power is on; when the **O** is depressed, the power is off.



When turned on, the unit will be in Standby Mode (unless disabled in the MISC menu, see section [5.6.4 Duty Cycle - DUTY](#)). The Standby Mode allows the user to change the strobe settings with the LEDs turned off. The STATUS LED will be red in the Standby Mode.

To toggle the LEDs ON or OFF, press the **LED ON/OFF** button. When the strobe is actively flashing, the STATUS LED will be green, the locked icon (insert lock symbol) will show on the display, and the unit will run continuously.

To turn the unit off, press the **O** on the POWER SWITCH.

### 3.3 Input/Output Connections

#### 3.3.1 Input

The INPUT connector (Aviation Plug M12 x 5) has 5 pins for connection of external trigger sources. These input signals can drive the strobe in the External Mode. The sensor input is compatible with most Monarch's inductive, proximity and optical sensors.



Connections are as follows:

#### Isolated Input:

- |   |                |   |
|---|----------------|---|
| 1 | Isolated Input | +5 to 12 V dc @ 50 mA max (brown)       |
| 2 | Isolated Input | -300 V dc Isolation, 10 kHz max (white) |

#### Sensor Input:

- |   |              |                           |
|---|--------------|---------------------------|
| 3 | +5 V out     | +5 V dc out 60 mA (blue)  |
| 4 | Signal Input | 3 to 5 V dc pulse (black) |
| 5 | Common (GND) | Common (gray)             |

#### 3.3.2 Output

The OUTPUT connector (Aviation Plug M12 x 4) has 4 pins, 3 of which are used for output signals. The strobe has two outputs. Pin 2 mimics the input pulse and can be used for daisy-chaining multiple strobes. Pin 1 is a controlled output from the strobe processor and is synchronous with the actual flash of the strobe. Any delays or scaling of the input are reflected in this second output pulse.

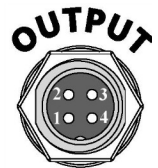

**Note:** Output pulses are not isolated.

#### Output Pinout:

- |   |              |  |
|---|--------------|--|
| 1 | Pulse Out    | 5 V (typ) Output @ 30 mA; controlled by strobe (brown) |
| 2 | Repeater Out | 5 V (typ) Output @ 30 mA; mimics Input pulse (white)   |
| 3 | Common (GND) | Common (blue)  |

## 4.0 MODES OF OPERATION

### 4.1 Internal Mode

The Internal Mode is the default mode of operation. It can also be selected in the MODE menu option.

In the Internal Mode, the strobe generates the flash rate set by the user. The user can set the flash rate in a number of ways:

#### 4.1.1 Rotary Knob

The user can dial the rotary knob in either direction and press the **MENU** button to set the desired flash rate.

#### 4.1.2 Arrow Buttons

This method uses the four arrow buttons on the control panel. Pressing any button will cause a digit on the flash rate display to start blinking – this is the digit that will be edited. Pressing the **UP ▲** or **DOWN ▼** button will increment or decrement the digit. The flash rate changes in real time if the strobe is flashing. Using the **LEFT ◀** or **RIGHT ▶** button will change the digit that blinks and allow the user to edit another digit. There is a rollover effect when the digit is changed – if incrementing the units, digit 99 will roll over to 100. Pressing and holding the **UP ▲** or **DOWN ▼** button will cause the current digit to auto increment or decrement. If the user does not increment or decrement a digit within 5 seconds, the edit mode will be canceled.

#### 4.1.3 Using the Numeric Touchscreen Keypad

To use the touchscreen keypad to enter a specific flash rate, press the **MENU** button once and the display will show the numeric keypad with numbers 1 – 9, 0, Decimal Point and ENTER.



The Flash rate will default to the last setting and show the digits you are entering. Simply enter your desired flash rate by pressing the digits followed by the Enter key. Note that this is a capacitive touch-sensitive keypad and will not respond if the user is wearing gloves.

#### 4.1.4 Doubling or Halving the Flash Rate

To double or halve the flash rate (to check for harmonics), press the **MENU** button twice and the display will show the x2 and ÷2 icons at the bottom of the display. At this point, pressing the **LEFT ◀** button will double or the **RIGHT ▶** button will halve the flash rate. (User can also touch the icons on the display.) To exit this mode, press the **ESCAPE** button.

### 4.2 External Mode

The strobe must be set in the External Mode from the MODE menu. When the strobe is in the External Input Mode, EXT will be displayed.

In the External Mode, the strobe is triggered by an external source connected to the Input connector. See section [3.3.1 Input](#).

In the External Input Mode, the user cannot make any flash rate adjustments; however, there are several functions that rely on the external input to provide a reference point for other internal functions. The flash rate is a function of the external input signal. This mode is used to synchronize the flash to an external event (for example, from an optical sensor) to stop or freeze motion using an external trigger. The flash will be triggered on the rising or falling edge (menu selectable) of the external input pulse.

**Note:** The input pulse can be prescaled using the PRESC menu option in the MISC menu.



### 4.3 ON Mode

The ON Mode is selected in the MODE menu option. In this mode, the strobe is continuously on and is used as a work lamp.

## 5.0 MENU SETTINGS

The menu settings are used to set several defaults in the Strobe or change the operating mode. To get to the settings, press the **MENU** button 3 times (bypass the numeric keypad and the  $x2 \div 2$  until the display shows *SEtUP* ). See page 15 for a full overview of the menu options and navigation.

Navigate through the menu using the up and down arrow buttons or rotary knob. Once the desired menu option is displayed, press the **MENU** button or knob to select that menu option. Within the menu options, the currently selected option is indicated by the Active SETTING  icon. Use the **ESCAPE** button to escape or back out of the menus.

*SEtUP* — Using the **DOWN ▼** button, the menu items appear as shown below. If the **UP ▲** button is used, the menu items will appear in the reverse order. To select the menu item, press the **MENU** button.

### 5.1 BRIGHTNESS - BRITe

There are three brightness levels: High, Medium and Low. This increases or decreases the LED intensity and DOES NOT AFFECT THE PULSE WIDTH. Use the brightness to adjust the intensity to an optimum level for the environment or to minimize glare from the target.

To change the brightness, press the **MENU** button when BRITe is displayed and then use the **UP ▲** or **DOWN ▼** buttons or turn the knob to choose the desired option (HI, MED, LOW). Then press the **MENU** button to select that option and press the **ESCAPE** button to exit.

### 5.2 WIDTH/CLARITY - WIDTh

Refer to [6.0 STROBE CLARITY](#) for further explanation on adjusting the clarity by changing the flash pulse width.

The Width menu option sets the flash duration which affects the perceived brightness and consequently the blur or clarity. This is not to be confused with BRIGHTNESS above. Flash pulse width can be adjusted in Degrees of Rotation, (proportional flash duration-changes with flash rate), Percent of Duty Cycle, or Time in milliseconds (msec-fixed flash duration). Degrees of Rotation and Percent of Duty Cycle are mutually exclusive and must be specified in the MISC, DUTY menu option prior to setting the Width.

#### 5.2.1 Degree of Rotation Adjustment - DEGS

If DEGREES is set as the Duty Cycle in the MISC menu, DEGS will be displayed when the WIDTH menu option is selected. Adjust the value using the arrow buttons or knob and then press the **MENU** button to accept, which will move to the TIME setting. Degrees can be set from 0.1° to 4.0° (3.0° for illumiNova 50).

**Note:** Setting the width in degrees keeps the width constant with flash rate as the stroboscope computes the degree angle in real time.

#### 5.2.2 Percent of Duty Cycle Adjustment - PCNT

If PERCENT is set as the Duty Cycle in the MISC menu, PCNT will be displayed when the WIDTH menu option is selected. Adjust the percentage using the arrow buttons or knob and then press the **MENU** button to accept, which will move to the TIME setting. Percent of Duty Cycle can be set up to 0.1% - 1.1%.

**Note:** Setting the width in Percent of Duty Cycle keeps the percentage constant with flash rate as the stroboscope computes the percentage in real time.

### 5.2.3 Time Pulse Duration Adjustment - TIME

Regardless of the Duty Cycle setting the MISC menu, the next width/clarity option shown when the **MENU** button or knob is pressed after setting Degrees or Percent is Time in microseconds. Adjust the time value using the arrow buttons or knob and then press the **MENU** button to or knob to accept. Time can be set from 1 to 150 microseconds.

**Note:** Setting the width by time keeps the flash duration constant, thus the clarity will decrease with increasing flash rate.

### 5.3 Mode of Operation - MODE

The MODE options are: Internal, External and ON. See Modes of Operation in section [3.2 Powering the Unit](#) for further details.

To change the Mode, press the **MENU** button when MODE is displayed and then use the **UP ▲** or **DOWN ▼** buttons or turn the knob to display the desired value (INT, EXT, ON). Then press the MENU button to select that option and press the **ESCAPE** button to exit.

### 5.4 JOG/DELAY

This feature is MODE dependent. In the Internal Mode, this menu option is called JOG; in the External Mode this menu option is called DELAY. Refer to [7.0 STROBE DELAY](#) for more details.

Press the **MENU** button to select this option, then press the **UP ▲** or **DOWN ▼** buttons or use the rotary knob to select one of the options below:

#### 5.4.1 NONE

To cancel the JOG/DELAY mode, press the **MENU** button when NONE is displayed.

#### 5.4.2 PHASE

To Jog or Delay by PHASE, press the **MENU** button when PHASE is displayed.

The phase value will be shown in degrees or percent. Use the arrow buttons or knob to set the desired value, then press the **MENU** button to accept and exit. Phase can be set from -360.0° to +360.0° or -100 to 100 if Duty Cycle is set to percent (see [5.6.4 Duty Cycle - DUTY](#)).

#### 5.4.3 TIME

To Jog or Delay by TIME, press the **MENU** button when TIME is displayed.

The time value will be shown in milliseconds. Use the arrow buttons or knob to set the desired value, then press the **MENU** button to accept and exit. Time can be set from -50.000 mSec to +50.000 mSec.

#### 5.4.4 VRPM (External Mode ONLY)

Virtual RPM (VRPM) is only applicable in External Mode. VRPM is an AUTO delay mode. To set VRPM, press the **MENU** button when VRPM is displayed.

The Virtual RPM value will be shown. Use the arrow buttons or knob to set the desired value, then press the **MENU** button to accept and exit. VRPM can be set from -60.0 RPM to +60.0 RPM.

Press the **ESCAPE** button to exit to the JOG/DELAY menu.

## 5.5 MEMORY - MEMORY (Internal Mode ONLY)

This menu option allows the user to recall or save up to ten settings. Press the **MENU** button to select the MEMORY menu.

Use the **RIGHT ►** button to toggle between RM (Recall Memory) or SM (Save Memory).

### 5.5.1 Recall Memory

**To RECALL a saved strobe setting:**

Make sure the display indicates RM (Recall Memory) and then use the **UP ▲** and **DOWN ▼** buttons or knob to choose one of ten memory locations (RM1, RM2...RM10) from which to load the memory setting. Press the **MENU** button to load from that location and the **ESCAPE** button to exit the menu. Note that the strobe settings change in real time as each memory location is displayed.

### 5.5.2 Save Memory

**To SAVE the current strobe setting into a memory location:**

Use the **RIGHT ►** button to get into the SAVE mode – indicated by SM on the display. Then use the **UP ▲** and **DOWN ▼** buttons or knob to choose one of ten memory locations (SM1, SM2...SM10) in which to save the settings. Press the **MENU** button to save settings to that location and press the **ESCAPE** button twice to exit the menu.

## 5.6 MISCELLANEOUS - MISC

When MISC is displayed, press the **MENU** button to select from the Miscellaneous menu options. Use the **UP ▲** and **DOWN ▼** buttons or knob to navigate and then press the **MENU** button to select one of the options below:

### 5.6.1 Decimal Point - DECPNT

Decimal Point determines the resolution of the displayed value. Press the **MENU** button to select and the current value will be displayed on the top line as indicated by the Active SETTING icon.

The options are - NONE, 1, 2, 3. Note that the display has six digits, and the strobe will automatically decrease the number of decimal points so as to not overflow the display. Use the **UP ▲** and **DOWN ▼** buttons or knob to choose the desired value and then press the **MENU** button to select that option. Press the **ESCAPE** button to exit to the MISC menu.

### 5.6.2 Scale - SCALE (External Mode ONLY)

Scale enables the displayed value in RPM/FPM/RPS/FPS to be multiplied by a scale factor in the range 0.001 to 65.000 to display in any units the user may want. The user can also add Engineering units.

When **SCALE** is displayed, press the **MENU** button to select and the display will show the current settings for scale and units. Use the touchscreen keypad to enter the desired scale value and press the Enter button on the touchscreen. The units line will begin flashing. Use the **UP ▲** and **DOWN ▼** buttons or knob to choose one of the default engineering units, then press the **MENU** button to select that option and exit to the MISC menu.

**Note:** The engineering unit selection is simply ASCII text and is not connected mathematically with the actual scale factor. The user can generate any 5 ASCII character string using the PC software and upload it via the USB port.

### 5.6.3 Standby - `STDBY`

The Standby feature determines if the LEDs start flashing or not when the unit is powered up. With Standby enabled (`Enb`) when the unit is powered up, the control panel is active and the user can make changes to the settings without the LEDs flashing. To have the LEDs start flashing, just press the **LED ON/OFF** button. Disable Standby by setting this option to `d15` if you want the strobe to remember the last status of LEDs flashing or not when the unit is powered off.

When `STDBY` is displayed, press the **MENU** button to select and the current selection will be displayed as indicated by the Active SETTING icon. Use the **UP ▲** and **DOWN ▼** buttons or knob to select `Enb` (Enabled) or `d15` (Disabled). Press the **MENU** button to select that option and then the **ESCAPE** button to exit to the MISC menu.

### 5.6.4 Duty Cycle - `DUTY`

Duty Cycle can be in Degrees of Rotation or in Percent of Duty Cycle. This affects how the width of the flash pulse is set in the WIDTH menu option. Degrees and Percent are mutually exclusive.

When `DUTY` is displayed press the **MENU** button to select and the current selection will be displayed as indicated by the Active SETTING icon. Use the **UP ▲** and **DOWN ▼** buttons or knob to select `dEG5` (Degrees) or `PERt` (Percent). Press the **MENU** button to select that option then the **ESCAPE** button to exit to the MISC menu.

### 5.6.5 Prescale - `PRESCL` (External Mode ONLY)

Prescale allows the user to set up the number of pulses per revolution (PPR) from an external input that will trigger a flash. The value can be adjusted from 1 PPR to 5000 PPR. If for example the input is from a 600 pulse per revolution optical encoder and the strobe is to flash once per revolution, set the prescale to 600.

When `PRESCL` is displayed, press the **MENU** button to select and the current prescale value (default is 1) will be displayed. Press the **UP ▲** and **DOWN ▼** buttons or knob to increment or decrement the digit. The **LEFT ◀** or **RIGHT ▶** buttons will change the digit that blinks and allow the user to edit another digit. Press the **MENU** button to accept the new value and exit from the Prescale menu.

### 5.6.6 Engineering Units - `UNITS`

Engineering Units options are Revolutions Per Minute (RPM), Revolutions Per Second (RPS), Flashes Per Minute (FPM), or Flashes Per Second (FPS).

When `UNITS` is displayed press the **MENU** button to select and the current selection will be displayed as indicated by the Active SETTING icon. Use the **UP ▲** and **DOWN ▼** buttons or knob to choose an option, then press the **MENU** button to select that option. Press the **ESCAPE** button to exit to the MISC menu.

### 5.6.7 Input Pulse Active Edge - `INPUT`

Input pulse active edge options are POS for positive leading edge, and NEG for negative going edge. The input pulse active edge is important when using an external source to trigger the flash. Choosing the wrong edge may cause the strobe to flash erratically.

When `INPUT` is displayed, press the **MENU** button to select and the current selection will be displayed as indicated by the Active SETTING icon. Use the **UP ▲** and **DOWN ▼** buttons or knob to choose an option, then press the **MENU** button to select that option. Press the **ESCAPE** button to exit to the MISC menu.

### 5.6.8 Output Pulse Polarity - `OUTP`

Output pulse polarity options are POS for positive leading edge, NEG for negative going edge, and SER (factory use only). The output pulse polarity is important when triggering an external device. Choosing the wrong edge may cause the device to function erratically.

When `OUTP` is displayed, press the **MENU** button to select and the current selection will be indicated by the Active SETTING icon. Use the **UP ▲** and **DOWN ▼** buttons or knob to choose an option, then press the **MENU** button to select that option. Press the **ESCAPE** button to exit to the MISC menu.

### 5.6.9 Backlight - `BLKIT`

This controls the display backlight ON or OFF condition.

When `BLKIT` is displayed, press the **MENU** button to select. Use the **UP ▲** and **DOWN ▼** buttons or knob to choose On or OFF (backlight will turn on or off), then press the **MENU** button to select that option. Press the **ESCAPE** button to exit to the MISC menu.

## 6.0 STROBE CLARITY

The width of the flash will determine the clarity (blur) of the target. The narrower the flash width the more focused the target will be. The width of the flash will also affect the brightness of the target, the wider the flash, the brighter the target will be perceived to be. This is not to be confused with the Brightness menu setting which adjusts intensity.

When the strobe is used on reciprocating or rotating targets there is a downside to the wider flashes. All strobes work by giving short bursts of light (the pulse width) at a rapid repetition rate (the flash rate). Strobes rely on the persistence of the human eye (the ability to remember an image) and its response to bright light to give an apparent stop motion image. Imagine a shaft rotating at 6000 RPM or one rotation every 1/100 of a second (10 msec). If the strobe flashes once every 10 msec for a brief moment, the user sees the flash at the same spot in the rotation of the shaft and the persistence of the eye remembers this until the next flash making the shaft appear to be stopped. As the target is rotating, there is some movement evident during the strobe flash. The longer the flash duration, the more obvious the rotation is and this increases the blur.

### 6.1 Calculating Blur

Blur can be calculated. If the shaft takes 10 msec to complete one revolution and the strobe flash duration is 100 µsec (1/100 of a millisecond), the shaft will turn:

$$(\text{flash duration/time per rotation}) \times 360^\circ, \text{ which is } (.0001/.01) \times 360 = 3.6^\circ$$

So you will see the shaft move 3.6°. As the flash pulse widens, you will see greater degrees of rotation which results in more blur and a brighter perceived illumination (the LEDs are on longer so the average light the eyes see is greater). The trade-off is blur versus brightness. One also has to take into account tangential velocity (rotational speed); the further away the rotating point is from the center axis, the faster the tangential velocity and the worse the blur appears to be. It is always the same number of degrees of rotation but the physical length of the blur gets bigger as the point moves faster. The strobe adjusts the width of the pulse automatically to keep the degree of rotation visible constant.

There are multiple ways of adjusting the flash pulse width and hence the brightness and consequently the blur. For setting clarity, see section [5.2 WIDTH/CLARITY - WIDTH](#) menu option.

## 6.2 Degrees of Rotation

This method (mutually exclusive with Percent of Duty Cycle – see MISC menu), is to adjust the flash pulse width for degree of rotation visible (blur). The user can set this from 0.1 to 4.0 degrees (3.0° for illumiNova 50) out of 360. The higher the setting the brighter the strobe appears to be but the more blurred the target is. The number of degrees is a proportional amount and remains constant as the flash rate increases or decreases. The strobe automatically calculates how wide the pulse width should be at different flash rates to keep the blur constant – the faster the flash rate the narrower the pulse width. The pulse width equals:

$$(\text{setting in degrees}/360) \times (1/\text{flash rate in Hz})$$

Thus the blur remains constant no matter what the flash rate. In the event that the setting exceeds the maximum settings when changing flash rate, the strobe will limit the value and the DEG icon will blink on the display.

## 6.3 Percent of Duty Cycle

The duty cycle between flashes is 100%. The user can adjust the duty cycle, which is the ratio of on time to off time, in percent (%). In the event that the setting exceeds the maximum settings when changing flash rate, the strobe will limit the value and the % icon will blink on the display.

## 6.4 Time Pulse Duration

This method adjusts the flash pulse width to a fixed number of microseconds. Here the user sets the flash pulse width in microseconds not degrees. As the flash rate increases the pulse width stays the same and the image will get brighter and more blurred as the flash width remains constant. The degree of rotation visible changes to keep the pulse width of the flash constant. The range of width is 1 to 150 microseconds. In the event that the setting exceeds the maximum settings when changing flash rate, the strobe will limit the value and the µsec icon will blink on the display.

## 7.0 STROBE DELAY

The illumiNova has multiple delay effects that can be used to inspect moving machinery in different ways. These delay effects are mode specific.

### 7.1 Internal Phase/Time Delay (JOG)

In the Internal Mode, the user can shift the apparent position of the flash by jogging. This can be done as a Phase Delay in degrees (-360.0° to +360.0°), Time Delay in milliseconds (-50.000 to +50.000 msec), and Percent Delay (-100% to +100%). Once the flash rate has been adjusted to give a stopped motion image, the PHASE or TIME arrow icons on the touchscreen can be used to increase or decrease the position of the image with respect to its original position by the amount set in the JOG menu option (see section [5.4 JOG/DELAY.](#))

### 7.2 External Delay

There are three External Delay options: Phase Delay, Time Delay and Virtual RPM (Auto). These modes are only active if an external trigger source is connected.

**Note:** The NONE menu setting turns the External Delay mode off (see section [5.4 JOG/DELAY.](#))

#### 7.2.1 External Phase Delay

In the External Phase Delay Mode, the flash is delayed from the external trigger by the number of degrees set in the DELAY PHASE menu (-360.0° to +360.0°) one revolution is 360°; or if the DUTY CYCLE is set to percent (-100% to +100%). The display will show the PHASE icon to indicate the delay mode.

### 7.2.2 External Time Delay

In the External Time Delay Mode the flash is delayed from the external trigger by the time in milliseconds (msec) set in the DELAY TIME menu (-50.000 to +50.000 msec). The TIME Delay is absolute and remains constant irrespective of the speed of the target. The display will show the TIME icon to indicate the Delay Mode.

### 7.2.3 External Virtual RPM (AUTO)

In the External Virtual RPM (VRPM or Auto) Mode the flash is automatically delayed in increasing or decreasing amounts after the external trigger pulse so that the image appears to rotate at a slow speed (Virtual RPM) as set in the VRPM menu (-60 to 60 RPM). This gives a “slow-motion” effect and enables the target to be examined as it moves through a complete cycle or revolution. The display will show the AUTO icon to indicate the Delay Mode with the virtual speed in RPM on the top line.

## 8.0 FAULT DETECTION

The strobe continuously monitors the high voltage, temperature and cooling fan for fault conditions. In the event that a fault is detected, the display will indicate *FAULT* on the top line of the display and the type of fault on the line below that. In the event of a voltage or temperature fault, the strobe will stop flashing and the fault is continuously displayed. If the fault should correct itself, the strobe will begin flashing again and the display will alternate between the regular display and the fault display. The event has to be cleared by the user using the **ESCAPE** button or **POWER SWITCH**.

In the event of a FAN fault, this will be indicated on the display and the strobe will continue flashing until a more serious fault occurs. A FAN fault can be caused by a clogged filter – see MAINTENANCE below.

## 9.0 MAINTENANCE

 Ensure the unit is turned OFF and AC power is disconnected before attempting any maintenance.

The illumiNova has no user serviceable parts inside the enclosure. The only item that requires maintenance is the cooling fan filter which is accessible on the right end of the unit looking at the rear of the enclosure. The filter will need cleaning periodically depending on the environment.

Removal requires the use of a Phillips-head screwdriver.

Undo the four screws retaining the fan guard (these are the inner screws – A) and remove from unit. This exposes the fan filter as shown above. Remove the foam filter. It can be cleaned by blowing with compressed air or washing gently with plain water. Once cleaned, replace the filter and the guard, and secure with the screws (A).

**Note:** A fan guard/filter replacement kit is available through Monarch. Contact the factory for details.

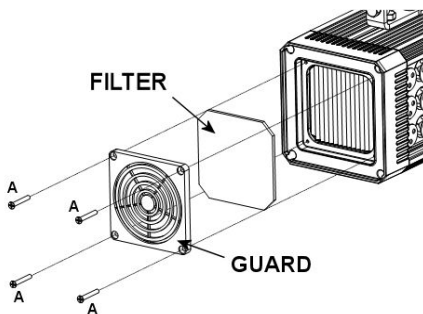

## 10.0 SPECIFICATIONS

Specifications*	50 (6 in.)	100 (1 ft.)	200 (2 ft.)	300 (3 ft.)	400 (4 ft.)	500 (5 ft.)	600 (6 ft.)	700 (7 ft.)	800 (8 ft.)
Controller/Display	6-digit numeric and 5-digit alphanumeric LCD with touch keypad and rotary tuning knob high-contrast blue background with backlight								
Flash Rate	30 to 999,999 FPM								
Accuracy	0.001% of setting or +/- 1 lsd								
Resolution	6 digits to 0.001								
Flash Duration (pulse width)	50	100 - 800 models							
Degrees	0.1-3.0°	0.1 to 4.0°							
Percent	0.1 to 0.8%	0.1 to 1.1%							
Time	1 to 150 µSec	1 to 150 µSec							
LED Array Size	6"	12"	24"	36"	48"	60"	72"	84"	96"
Number of LEDs	54	108	216	324	432	540	648	756	864
<b>Lux Output @ 6000 FPM/Spot Lens</b>									
@ 100 cm (39.37")	3700	7250	8150	8430	8500	8570	8600	8660	8600
@ 200 cm (78.74")	1000	2290	3760	4190	4350	4430	4450	4500	4500
Available Lens Types	Spot: provides narrowest, brightest illumination area Wide: produces a horizontally wide light output allowing smaller strobes to illuminate wider processes Flood: produces a vertically wide light output to illuminate a larger linear process area								
External Trigger Input	Open collector, dry contact input for sensors (3-5 V dc pulse) provides 5 V dc sensor power isolated input 5-12 V dc 50 mA max								
Prescaler Input	Adjustable from 0-5000 pulses per revolution								
Digital Output	Provides 3.3 V dc TTL output								
Programmable Memory	10 setpoints								
Jog/Delay	Phase: -360.0° to +360.0° Time: -50.000 to +50.000 mSecs; VRPM: -60 to +60 RPM (External Mode ONLY)								
Input Power	115 or 230 V ac ±10%, 50/60 Hz								
VA Max	37	60	110	160	260	325	360	430	470
<b>Dimensions</b>									
Height	4.37 in. / 11.11 cm								
Width	4.37 in. / 11.11 cm								
Length (inch/cm)	9.43 23.97	15.44 39.21	27.43 69.69	39.93 101.44	51.93 131.92	63.93 162.38	75.93 192.88	87.93 223.34	99.93 253.84
Weight (lbs./kg)	4.78 21.68	7.42 3.37	13.26 6.02	19.18 8.70	25.02 11.35	30.10 13.65	36.69 16.64	42.53 19.29	48.36 21.94
Housing Material	Extruded and die-cast aluminum, powder coated								
Housing Rating	IP20								
Safety	<b>This product is designed to be safe for indoor use under the following conditions (per IEC61010-1).</b>								
Operating Temperature	32-104 °F (0-40 °C)								
Humidity	Maximum relative humidity 80% for temperature up to 88 °F (31 °C) decreasing linearly to 50% relative humidity at 104 °F (40 °C)								

\*Specifications are subject to change without notice.

### 10.1 Compliance

CE compliant. Low Voltage Directive (LVD) 2014/35/EU

Electromagnetic Compatibility Directive (EMC)

Restriction of Hazardous Substances (RoHS) Directive 2011/65/EU

*Manufactured in an ISO9001 facility.*



## 11.0 SENSORS AND ACCESSORIES

### Sensors

<b>RLS-W</b>	PN: 6180-080	Rugged Laser Sensor with removable 3 m cable, watertight M12 connector to tinned leads
<b>ROLS-W</b>	PN: 6180-030	Remote Optical Laser Sensor with 8 ft. [2.5 m] cable, 3 tinned leads
<b>ROS-W</b>	PN: 6180-056	Remote Optical Sensor with 8 ft. [2.5 m] cable
<b>ROS-W-25</b>	PN: 6180-056-25	Remote Optical Sensor with 25 ft. [7.6 m] cable
<b>IRS-W</b>	PN: 6180-021	Infrared Sensor with 8 ft. [2.5 m] cable for use without reflective target at 0.5 inch [12 mm] gap
<b>MT-190W</b>	PN: 6180-037	Amplified Magnetic Sensor



**RLS-W**  
PN: 6180-080



**ROLS-W**  
PN: 6150-030

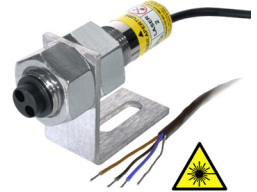

**ROS-W**  
PN: 6180-056

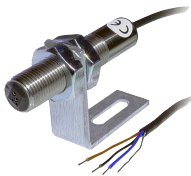

**IRS-W**  
PN: 6150-021



**MT-190W**  
PN: 6180-037

**Accessories**

**Remote Controller**

PN: 6280-090

Remote Controller with LCD provides remote operation up to 100 feet away from strobe; includes 25 ft. Cat 5E interconnect/ power cable

**Input Cable**

PN: 6280-091

Input Cable, 5 m with 5-pin M12 connector and tinned leads

**Output Cable**

PN: 6280-092

Output Cable, 5 m with 4-pin M12 connector and tinned leads

**Mounting Hardware Set**

PN: 6280-093

Spare mounting hardware set includes two positionable “L” brackets and 80/20 mounting hardware

**Input Connector**

PN: 6280-095

5-pin Aviation M12 input connector only

**Output Connector**

PN: 6280-094

4-pin Aviation M12 output connector only

**Daisy Chain Cable**

PN: 6280-098

15 ft. [4.57 m] daisy chain cable with 5-pin threaded input connector and 4-pin threaded output connector

**Input Cable BNC Connector**

PN: 6280-096

15 ft. [4.57 m] 5-pin 12M connector to BNC



**Remote Controller**  
PN: 6280-090



**Input Cable**  
PN: 6280-091



**Output Cable**  
PN: 6280-092



**Mounting Hardware Set**  
PN: 6280-093



**Input Connector**  
PN: 6280-095



**Output Connector**  
PN: 6280-094



**Daisy Chain Cable**  
PN: 6280-098



**Input Cable BNC Connector**  
PN: 6280-096

# IllumiNova® Menu Navigation Quick Start

POWER button



654321  
RPM

START  
SCREEN



KEYPAD

X2 / +2

BRITE

WIDTH

MODE

JOG

MEMRY

MISC

## KEY

- Menu/Enter for navigation and to save setting changes
- Indicates current setting
- RETURN or EXIT button
- Down/Up navigation button
- Up/Down to change number values
- Left/Right to select digits to change



Low, High, Med, dial or up/dwn to define choice (to SET) (to return to menu settings)

DEG/PCNT displayed, TIME displayed dial or up/dwn and <> to change values, then to set

Int, Ext, ON (to SET) ON = Lamp for ON Off, reset Mode to Int or Ext to disable lamp mode

NONE, PHASE, TIME, dial or up/dwn> to change modes input number input number dial or up/dwn and <> to change values, then to set

RM (1-10) or ► for SM (1-10) Load current flash setting into SM (1-10) dial or up/dwn to change memory locations overwrites any preset # (to return to menu settings)

Recall setting RM (1-10) to set flash rate dial or up/dwn to locate memory setting, then to use as current flash rate (to return to menu settings)

Subset of miscellaneous option settings

DECPY none, 1, 2, 3 (to SET) dial or up/dwn to define choice (to SET) (to return to menu settings)

SCALE use on-screen touch screen to input values and on-screen to set scale values 'flashing', use dial to select (ft/s, ft/m, i/sec, i/m, ... h--) (to return to menu settings)

STANDBY Enabled (Enb), Disabled (dIS) dial or up/dwn to define choice (to SET) (to return to menu settings)

DUTY DEG or Percent (PErCnt %) dial or up/dwn to select (to SET) (to return to menu settings)

PRESCALE dial or up/dwn and <> to change values, then to set

UNITS dial or up/dwn to define choice RPS, RPM, FPS, FPM (to SET)

INPUT POS, nEG, (to SET)

OUTP POS, nEG, SEr (to SET)

BKLIT ON, OFF (to SET)

# The Professional's Choice

Monarch Instrument is committed to excellence and quality in manufacturing, sales, and service.



Portable Tachometers



Track-It™ Data Loggers



Panel Tachometers



Fixed Mounted Strobes



Portable Strobes



Frequency Converters



Speed Sensors

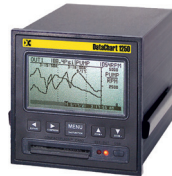

DataChart™ Paperless Recorders



15 Columbia Drive, Amherst NH 03031 USA  
Tel.: (603) 883-3390 // Fax: (603) 886-3300  
Email: [support@monarchinstrument.com](mailto:support@monarchinstrument.com)  
Website: [www.monarchinstrument.com](http://www.monarchinstrument.com)