

USER INSTRUCTIONS

Intelligent, Economy 2-wire Transmitter

MINIPAQ[®]-HLP



The user instruction must be read prior to adjustment and/or installation.
All information subject to change without notice.

MEASURE OF SUCCESS



INOR

INOR Process AB, PO Box 9125, SE-200 39 Malmö, Sweden,
Phone: +46(040)31 25 60, Fax: +46(040)31 25 70, E-mail: info@inor.se

INOR Transmitter OY, Unikkotie13, FI-01300 Vantaa, Finland,
Phone: +358-9-83850219, Fax: +358-9-83850219, E-mail: jari.stadig@inor.fi

INOR Transmitter GmbH, Rodenbacher Chaussee 6,
DE-63457 Hanau-Wolfgang, Germany,
Phone: +49(0)6181-582940, Fax: +49(0)6181-582944, E-mail: inor.gmbh@t-online.de

INOR Transmitter Inc., 7 Dearborn Road, Peabody, MA 01960, USA,
Phone: +1(978) 826-6900/(262) 670-9050,
Fax: +1(978) 535-3882/(262) 670-9001, E-mail: service@inor.com

www.inor.com, www.inor.se



This product should not be mixed with other kind of scrap, after usage.
It should be handled as an electronic/electric device.

MEASURE OF SUCCESS

GENERAL INFORMATION

MinIPAQ-HLP is a two-wire transmitter intended to be used in industrial environment.

The transmitter is configured from a PC, via a USB port, by using the MinIPAQ Soft program. Use MinIPAQ Soft version 1.23.01 or later. When the transmitter is set from a PC no calibration is needed. The manual is on-line. MinIPAQ Soft is compatible with Windows 98SE, Windows NT Workstation 4.0, Windows 2000 and Windows XP.

DATA (shortform)

Input	See "Input Connections"
Sensor failure	Upscale, downscale or off
Adjustments - Zero	Any value within range limits
Adjustments - Minimum spans	
Pt100, Pt1000, Ni100, Ni120, Ni1000	10°C / 18°F
Cu10	100°C / 180°F
T/C	2 mV
Output	4-20 mA, temperature linear
Operating temperature	-40 to +85°C / -40 to +185°F
Galvanic isolation	No
Power supply	8 to 32 VDC
Typical accuracy	±0.15 % of temperature span
Connection head	DIN B or larger

CONFIGURATION

Before making a configuration of MinIPAQ-HLP you need to do following:

1. Install the PC configuration software ConSoft in your PC. The software is included in the PC Configuration Kit 70CFGUS001 and can also be downloaded from the web site www.inor.com.
2. Install the PC configuration software MinIPAQ Soft, version 1.23.01 or later, in your PC. The software is included in the PC Configuration Kit 70CFGUS001 and can also be downloaded from the web site www.inor.com.
3. Install the driver for the INOR USB Interface. The driver is included in the PC Configuration Kit 70CFGUS001.

Configuration procedure:

The help file in MinIPAQ Soft contains complete information about the configuration procedure. Here is a short-form guide:

1. Connect the MinIPAQ-HLP to the PC via the USB Interface. Configuration can be performed with or without connected power supply.
2. In ConSoft, click on "Connect", and the software will automatically recognize the connected transmitter.
3. Click on the highlighted "MinIPAQ" in the menu tree of ConSoft and the "MinIPAQ Soft" configuration window will open.
4. Be sure to set the Communication port in MinIPAQ Soft (under Options) to the same port No. as indicated in the lower left corner of the ConSoft window, e.g. COM8.
5. In the configuration window you can set the following parameters:
 - a. Input (RTD or Thermocouple type)
 - b. 3- or 4-wire connection (for RTD input)
 - c. Activation of Cold Junction Compensation (for T/C input)
 - d. Measuring range in three different engineering units
 - e. Upscale or downscale action at sensor break or short-circuit
 - f. Compensation for known sensor errors
 - g. Activation of a Low pass filter
6. The selected configuration is downloaded to the transmitter by clicking the button "Transfer to transmitter". If the transmitter is in operation during transmission from the PC, the transmitter output is frozen. When the transfer is complete, the transmitter begins using the new parameters directly.

OUTPUT LOAD DIAGRAM

Permissible R_{Load} at 22 mA output

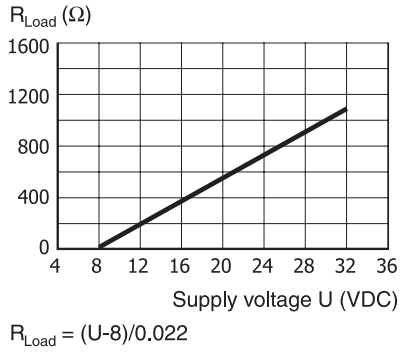

DIMENSIONS

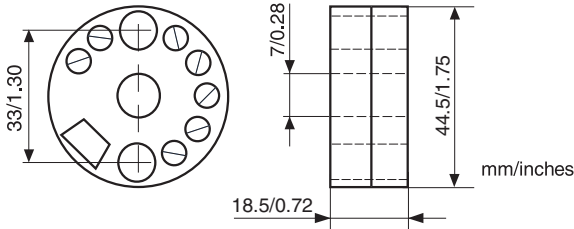

CALIBRATION

It is recommended to check the calibration once a year. Use equipment with an inaccuracy of at least 5 times better than the checked transmitter, e.g. if you are checking a transmitter with an inaccuracy of maximum 0.1% use instrument with an inaccuracy of maximum 0.02%. Use the MinIPAQ Soft Basic Calibration function in the Options menu, and follow the instructions on the screen.

LIMITED WARRANTY

INOR Process AB, or any other affiliated company within the Inor Group (hereinafter jointly referred to as "Inor"), hereby warrants that the Product will be free from defects in materials or workmanship for a period of five (5) years from the date of delivery ("Limited Warranty"). This Limited Warranty is limited to repair or replacement at Inor's option and is effective only for the first end-user of the Product. Upon receipt of a warranty claim, Inor shall respond within a reasonable time period as to its decision concerning:

- 1 Whether Inor acknowledges its responsibility for any asserted defect in materials or workmanship; and, if so,
- 2 the appropriate cause of action to be taken (i.e. whether a defective product should be replaced or repaired by Inor).

This Limited Warranty applies only if the Product:

- 1 is installed according to the instructions furnished by Inor;
- 2 is connected to a proper power supply;
- 3 is not misused or abused; and
- 4 there is no evidence of tampering, mishandling, neglect, accident damage, modification or repair without the approval of Inor or damage done to the Product by anyone other than Inor.

This Limited Warranty is provided by Inor and contains the only express warranty provided.

INOR SPECIFICALLY DISCLAIMS ANY EXPRESS WARRANTY NOT PROVIDED HEREIN AND ANY IMPLIED WARRANTY, GUARANTEE OR REPRESENTATION AS TO SUITABILITY FOR ANY PARTICULAR PURPOSE, PERFORMANCE, QUALITY AND ABSENCE OF ANY HIDDEN DEFECTS, AND ANY REMEDY FOR BREACH OF CONTRACT, WHICH BUT FOR THIS PROVISION, MIGHT ARISE BY IMPLICATION, OPERATION OF LAW, CUSTOM OF TRADE OR COURSE OF DEALING, INCLUDING IMPLIED WARRANTIES OF MERCHANTABILITY AND FITNESS FOR A PARTICULAR PURPOSE. EXCEPT AS PROVIDED HEREIN, INOR FURTHER DISCLAIMS ANY RESPONSIBILITY FOR LOSSES, EXPENSES, INCONVENIENCES, SPECIAL, DIRECT, SECONDARY OR CONSEQUENTIAL DAMAGES ARISING FROM OWNERSHIP OR USE OF THE PRODUCT.

Products that are covered by the Limited Warranty will either be repaired or replaced at the option of Inor. Customer pays freight to Inor, and Inor will pay the return freight by post or other "normal" way of transport. If any other type of return freight is requested, customer pays the whole return cost.

CONNECTIONS

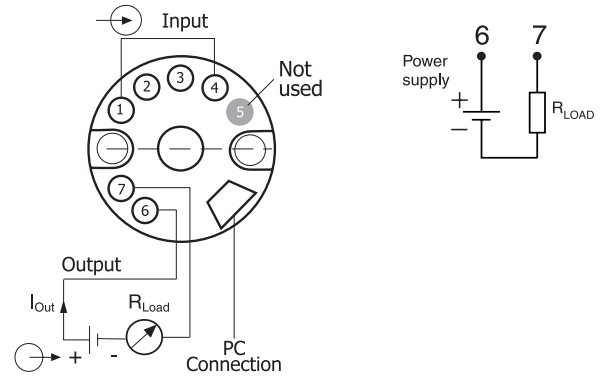

INPUT CONNECTIONS

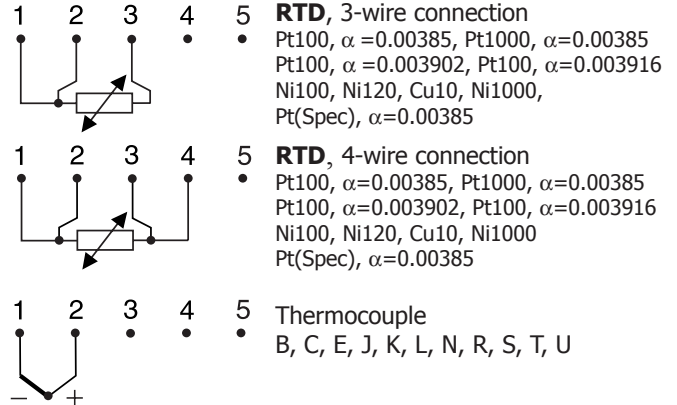

MOUNTING

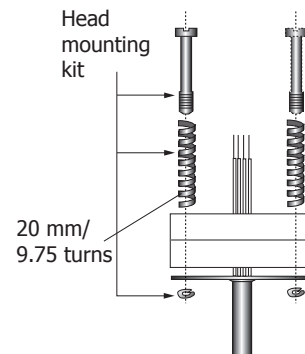

ORDERING INFORMATION

MinIPAQ-HLP	70MQHLP002
Configuration	70CAL00001
PC configuration kit (USB-conn.)	70CFGUS001
Head mounting kit	70ADA00017
Rail mounting kit	70ADA00013