

Micro Motion™ T-Series Coriolis Flow and Density Meters



Superior flow measurement in a single straight tube flow meter

- Built-in balance bar provides the best single straight tube mass flow measurement to reduce variability in process control

Comprehensive hygienic application coverage

- Easy to clean in place (CIP) and steam in place (SIP) with EHEDG certified, 3-A authorized, ASME® BPE design
- Diameter matches standard process tubing for draining in any orientation
- Fast product change-over with self-draining design and no profile effects
- Single flow path is easy to clean mechanically
- Highly-polished surface finish for ultra-pure fluids

Superior reliability

- No moving parts to wear or replace minimizes maintenance for long-term reliability
- Full secondary pressure containment available

Micro Motion T-Series Coriolis Flow and Density Meters

Micro Motion Coriolis meters meet a vast range of application needs, ranging from extreme low-flow up to high-flow, high-capacity lines. Cryogenic, hygienic, high-temperature, and high-pressure— Micro Motion meters can handle them all. Micro Motion meters are available with a variety of wetted parts to ensure the best material compatibility.

Coriolis meters

Coriolis meters offer dramatic benefits over traditional volumetric measurement technologies. Coriolis meters:

- Deliver accurate and repeatable process data over a wide range of flow rates and process conditions.
- Provide direct inline measurement of mass flow and density, and also measure volume flow and temperature—all from a single device.
- Have no moving parts, so maintenance costs are minimal.
- Have no requirements for flow conditioning or straight pipe runs, so installation is simplified and less expensive.
- Provide advanced diagnostic tools for both the meter and the process

Tip

For help determining which Micro Motion products are right for your application, see the *Micro Motion Technical Overview and Specification Summary* and other resources at www.emerson.com/flowmeasurement.

T-Series Coriolis meters

Our straight tube meter design is based on the ASME Bioprocessing Equipment Standard. With optional sanitary fittings, Micro Motion T-Series meters meet 3-A Sanitary Standards for Milk and Milk Products, are EHEDG clean-in-place approved, and feature a standard surface finish of 32 μ -inch Ra (0.8 μ -meter)—and 15 μ -inch Ra (0.38 μ -meter) is an available option.

The Micro Motion T-Series single straight-tube design makes these meters self-draining, and allows them to be cleaned or sterilized in place (CIP/SIP). The straight flow path also resists plugging, and can be pigged.

Smart Meter Verification™: advanced diagnostics for your entire system

- A comprehensive test that can be run locally or from the control room to provide confidence in your meter functionality and performance
- Verifies that your meter performs as well as the day it was installed, giving you assurance in less than 90 seconds
- Save significant expenditure by reducing labor and outsourced calibration service costs while eliminating process interruption

Measurement principles

As a practical application of the Coriolis effect, the Coriolis mass flow meter operating principle involves inducing a vibration of the flow tube through which the fluid passes. The vibration, though it is not completely circular, provides the rotating reference frame which gives rise to the Coriolis effect. While specific methods vary according to the design of the flow meter, sensors monitor and analyze changes in frequency, phase shift, and amplitude of the vibrating flow tubes. The changes observed represent the mass flow rate and density of the fluid.

Mass flow measurement

The measuring tubes are forced to oscillate producing a sine wave. At zero flow, the two tubes vibrate in phase with each other. When flow is introduced, the Coriolis forces cause the tubes to twist resulting in a phase shift. The time difference between the waves is measured and is directly proportional to the mass flow rate.

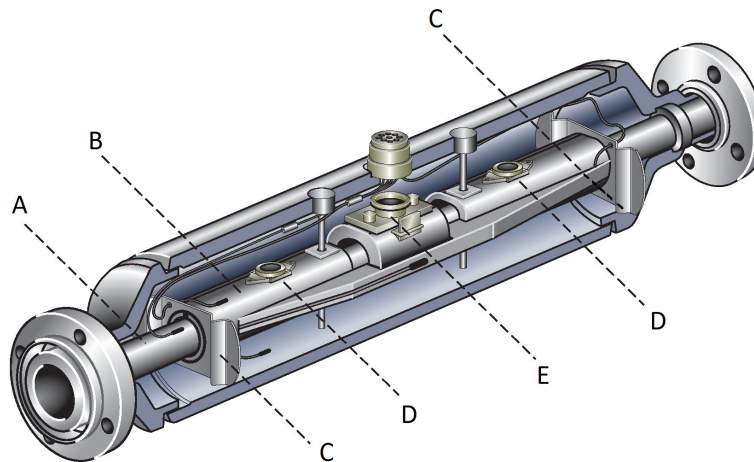

- A. Flow Tube
- B. Reference Tube
- C. Case Transition Bracket
- D. Pickoff Coil
- E. Drive Coil

Density measurement

The measuring tubes are vibrated at their natural frequency. A change in the mass of the fluid contained inside the tubes causes a corresponding change to the tube natural frequency. The frequency change of the tube is used to calculate density.

Temperature measurement

Temperature is a measured variable that is available as an output. The temperature is also used internal to the sensor to compensate for temperature influences on Young's Modulus of Elasticity.

Meter characteristics

- Measurement accuracy is a function of fluid mass flow rate independent of operating temperature, pressure, or composition. However, pressure drop through the sensor is dependent upon operating temperature, pressure, and fluid composition.
- Specifications and capabilities vary by model and certain models may have fewer available options. For detailed information regarding performance and capabilities, either contact customer service or visit www.emerson.com/flowmeasurement.
- The letter at the end of the base model code (for example T100T) represents wetted part titanium material surface finish: T= 32 Ra (0.8 μm); F= 15 Ra (0.38 μm). Detailed information about the complete product model codes are described later in this document.

Performance specifications

Reference operating conditions

For determining the performance capabilities of our meters, the following conditions were observed / utilized:

- Water at 68 °F (20 °C) to 77 °F (25 °C) and 14.5 psig (1.000 barg) to 29 psig (2.00 barg)
- Air and natural gas at 68 °F (20 °C) to 77 °F (25 °C) and 500 psig (34 barg) to 1,450 psig (100 barg)
- Accuracy based on industry leading accredited calibration standards according to ISO 17025/IEC 17025
- A density range up to 3 g/cm³ (3,000 kg/m³) on all models

Accuracy and repeatability

Accuracy and repeatability on liquids and slurries

Performance specifications	Calibration code Z	Calibration code 1	Calibration code K ⁽¹⁾
Mass flow accuracy ⁽²⁾	±0.15% of rate	±0.10% of rate	±0.10% of rate
Volume flow accuracy ⁽²⁾⁽³⁾	±0.25% of rate	±0.15% of rate	±0.15% of rate
Mass flow repeatability	0.075% of rate	0.005% of rate	0.005% of rate
Volume flow repeatability	0.125% of rate	0.075% of rate	0.075% of rate
Density accuracy	±0.002 g/cm ³ (±2 kg/m ³)	±0.001 g/cm ³ (±1 kg/m ³)	±0.0005 g/cm ³ (±0.5 kg/m ³)
Density repeatability	0.001 g/cm ³ (1 kg/m ³)	0.0005 g/cm ³ (0.5 kg/m ³)	0.00025 g/cm ³ (0.25 kg/m ³)
Temperature accuracy	±1 °C ±0.5% of reading		
Temperature repeatability	0.2 °C		

(1) Calibration code K is not available for T025.

(2) Stated flow accuracy includes the combined effects of repeatability, linearity, and hysteresis.

(3) At calibration conditions and fluid.

Accuracy and repeatability on gases

Performance specification	All models
Mass flow accuracy ⁽¹⁾	±0.5% of rate
Mass flow repeatability ⁽¹⁾	0.25% of rate
Temperature accuracy	±1 °C ±0.5% of reading
Temperature repeatability	0.2 °C

(1) Stated flow accuracy includes the combined effects of repeatability, linearity, and hysteresis

Liquid flow rates

Nominal flow rate

Micro Motion has adopted the term nominal flow rate, which is the flow rate at which water at reference conditions causes approximately 14.5 psig (1.000 barg) of pressure drop across the meter. For T-Series sensors, the nominal flow rate is also the maximum flow rate.

Mass flow rates for all models

Model	Nominal line size		Nominal/maximum flow rate	
	inch	mm	lb/min	kg/h
T025	0.25	DN6	25	680
T050	0.50	DN15	140	3,800
T075	0.75	DN20	500	14,000
T100	1	DN25	1,100	30,000
T150	1.5	DN40	3,200	87,000

Volume flow rates for all models

Model	Nominal/maximum flow rate		
	gal/min	barrels/h	l/h
T025	3	4.3	680
T050	17	24	3,800
T075	62	89	14,000
T100	132	189	30,000
T150	383	547	87,000

Gas flow rates

When selecting sensors for gas applications, pressure drop and turndown through the sensor is dependent upon operating temperature, pressure, and fluid composition. Therefore, when selecting a sensor for any particular gas application, it is highly recommended that each sensor be sized using the sizing and selection tool at www.emerson.com/flowmeasurement that will report both the actual velocity and the sonic velocity for each flow rate and meter size considered.

The following table indicates mass flow rates that produce approximately 10 psig (0.69 barg) pressure drop on natural gas with molecular weight of 17 at 60 °F (15.6 °C) and 500 psig (34.47 barg).

Gas flow rates for all models

Model	Mass		Volume	
	lb/min	kg/h	SCFM	Nm ³ /h
T025	2.8	76	64	100
T050	20	540	460	780
T075	75	2,000	1,700	2,800
T100	160	4,300	3,700	6,300
T150	400	10,000	9,500	16,000

Standard (SCFM) reference conditions for natural gas with molecular weight of 17 are 14.7 psig (1.014 barg) and 60 °F (15.6 °C).

Zero stability

Zero stability is used when the flow rate approaches the low end of the flow range where the meter accuracy begins to deviate from the stated accuracy rating, as depicted in the turndown section. When operating at flow rates where meter accuracy begins to deviate from the stated accuracy rating, accuracy is governed by the formula: $\text{accuracy} = (\text{zero stability}/\text{flow rate}) \times 100\%$. Repeatability is similarly affected by low flow conditions.

Turndown capabilities

The graph and table below represent an example of the measurement characteristics under various flow conditions. At flow rates requiring large turndowns (greater than 20:1), the zero stability values may begin to govern capability dependent upon flow conditions and meter in use.

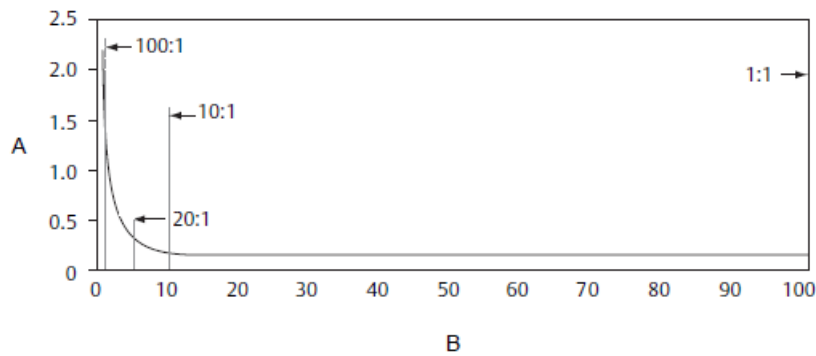

A. Accuracy, %
 B. Flow rate, % of nominal

Turndown from nominal flow rate	100:1	20:1	10:1	1:1
Accuracy	±% 1.50	±% 0.30	±% 0.10	±% 0.10
Pressure drop	~ 0 psig (0.00 barg)	0.06 psig (0.0041 barg)	0.22 psig (0.0152 barg)	14.3 psig (0.986 barg)

Zero stability for all models

Model	Zero stability	
	lb/min	kg/h
T025	0.0038	0.10
T050	0.021	0.57
T075	0.075	2.0
T100	0.165	4.50
T150	0.48	13.0

Process pressure ratings

Sensor maximum working pressure reflects the highest possible pressure rating for a given sensor. Process connection type and environmental and process fluid temperatures may reduce the maximum rating.

All sensors comply with Council Directive 2014/68/EU on pressure equipment.

Sensor maximum working pressure for all models

All T-Series sensors = 1,450 psig (99.97 barg)

Case pressure

Case pressure for all models

Model ⁽¹⁾	Pressure
All T-Series sensors	1,450 psig (99.97 barg)
All T-Series sensors with purge fittings	725 psig (49.99 barg)

(1) One time case containment pressure over a period of a maximum of 10 hours.

Operating conditions: Environmental

Vibration limits

Meets IEC 60068-2-6, endurance sweep, 5 to 2000 Hz, 50 sweep cycles at 1.0 g.

Temperature limits

Sensors can be used in the process and ambient temperature ranges shown in the temperature limit graphs. For the purposes of selecting electronics options, temperature limit graphs should be used only as a general guide. If your process conditions are close to the gray area, consult with your Micro Motion representative.

Note

- In all cases, the electronics cannot be operated where the ambient temperature is below -40 °F (-40.0 °C) or above 140 °F (60.0 °C). If a sensor is to be used where the ambient temperature is outside of the range permissible for the electronics, the electronics must be remotely located where the ambient temperature is within the permissible range, as indicated by the shaded areas of the temperature limit graphs.
- Temperature limits may be further restricted by hazardous area approvals. Refer to the hazardous area approvals documentation shipped with the sensor or available at www.emerson.com/flowmeasurement.
- The extended-mount electronics option allows the sensor case to be insulated without covering the transmitter, core processor, or junction box, but does not affect temperature ratings. When insulating the sensor case at elevated process temperatures above 140 °F (60.0 °C), ensure electronics are not enclosed in insulation as this may lead to electronics failure.

Ambient and process temperature limits for all models

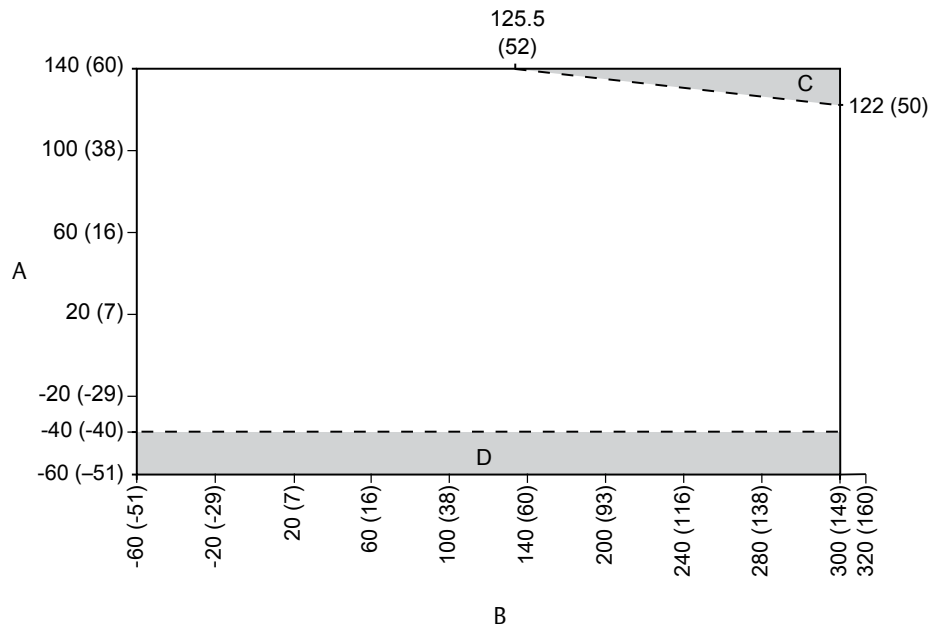

- A. Ambient temperature of core processor or transmitter in °F (°C)
- B. Maximum process temperature in °F (°C)
- C. Mount transmitter remotely and use a junction box
- D. Temperature is below -40 °F (-40 °C); mount transmitter remotely and use a junction box

Operating conditions: Process

Process temperature effect

For mass flow measurement, process temperature effect is defined as the change in sensor flow accuracy due to process temperature change away from the calibration temperature. Temperature effect can be corrected by zeroing at the process conditions.

Process temperature effect for all models

Model	Mass flow rate (% of maximum rate) per °C
All T-Series sensors	±0.002



Process pressure effect

Process pressure effect is defined as the change in sensor flow and density accuracy due to process pressure change away from the calibration pressure. This effect can be corrected by dynamic pressure input or a fixed meter factor. For proper setup and configuration, see the *Micro Motion T-Series Hygienic Coriolis Flow and Density Meters Installation Manual*.

Model code	Liquid or gas flow (% of rate) per pressure measurement	Density		
		g/cm ³ per psig	kg/m ³ per barg	kg/m ³ per kPa
T025	None	0.0000942	1.37	137.0
T050	None	0.0000357	0.518	51.8
T075	None	0.0000255	0.370	37.0
T100	None	0.0000154	0.223	22.3
T150	None	0.0000109	0.158	15.8

Hazardous area classifications

Approvals and certifications

Type	Approval or certification (typical)	
CSA and CSA C-US	Ambient temperature: -40 °F (-40.0 °C) to 140 °F (60.0 °C) Class I, Div. 1, Groups C and D Class I, Div. 2, Groups A, B, C, and D Class II, Div.1, Groups E, F, and G	
ATEX		II 2G Ex ib IIB/IIC T6/T5/T4...T1 Gb II 2D Ex ib IIIC T* °C Db IP66/IP67
		II 3G Ex nA IIC T6/T5/T4...T1 Gc II 3D Ex tc IIIC T* °C Dc IP66/IP67
IECEX	Ex ib IIB/IIC T6/T5/T4...T1 Gb, Ex ib IIIC T* °C Db IP66/IP67 Ex nA IIC T6/T5/T4...T1 Gc, Ex tc IIIC T* °C Dc IP66/IP67	
NEPSI	Ex ib IIB/IIC T1–T6 Gb T450°C–T85°C Ex T6/T5/T4... Gb Ex nA IIC T1–T6 T450°C–T85°C Ex T6/T5/T4...T1 Gc, Ex tD A22 IP66/IP67 T95°C ~ T182°C	
Ingress Protection Rating	IP66/IP67/IP69(K) ⁽¹⁾	
EMC effects	Complies with EMC directive 2014/30/EU per EN 61326 Industrial	
	Complies with NAMUR NE-21 (Edition: 2017-08-01)	

(1) IP69(K) is available on some transmitters. For details, see the transmitter Product Data Sheet for details.

Note

- Approvals shown are for T-Series meters configured with a 5700 transmitter. Meters with integral electronics may have more restrictive approvals.
- When a meter is ordered with hazardous area approvals, detailed information is shipped along with the product.
- You can find more information about hazardous approvals, including detailed specifications and temperature graphs for all meter configurations on the T-Series product page at www.emerson.com/flowmeasurement.

Industry standards

Type	Standard
Sanitary applications	<ul style="list-style-type: none"> ■ ASME Bioprocessing Equipment Standard — 1997 ■ 3-A Sanitary Standards for Milk and Dairy Products ■ EHEDG Machinery Directive 98/37/EC, annex 1, section 2.1
Industry standards and commercial approvals	<ul style="list-style-type: none"> ■ NAMUR: NE132 (Burst pressure, sensor flange to flange length), NE131 ■ Pressure Equipment Directive (PED) ■ Canadian Registration Number (CRN) ■ Dual Seal ■ ASME B31.1 power piping code and ASME B31.3 process piping code ■ SIL2 and SIL3 safety certifications

Important

Some models do not meet all of the listed standards. Contact a sales representative for more information.

Transmitter interface

T-Series sensors are highly customizable to provide a configuration that is tailor-fit to specific applications.

Robust transmitter offerings allow a multitude of mounting options:

- Compact mounting integral to the sensor
- Field mount variants for harsh conditions
- Compact control room DIN rail packages for optimal locating in a control cabinet
- Specific fit-for-purpose solutions for two-wire connectivity or filling and dosing machinery integration

T-Series sensors are available with an expansive selection of input and output connectivity options including the following:

- 4-20 mA
- HART™
- WirelessHART™
- DeviceNet
- EtherNet/IP
- Profinet
- FOUNDATION™ fieldbus
- PROFIBUS
- Modbus®
- Other protocols may be available on request

Physical specifications

Materials of construction

General corrosion guidelines do not account for cyclical stress, and therefore should not be relied upon when choosing a wetted material for your Micro Motion meter. For material compatibility information, see the [Micro Motion Corrosion Guide](#).

Flow tubes

Model	All models Titanium ASTM Grade 9	Sensor weight ⁽¹⁾
T025	•	14 lb (6 kg)
T050	•	16 lb (7 kg)
T075	•	33 lb (15 kg)
T100	•	58 lb (26 kg)
T150	•	137 lb (62 kg)

(1) Weight specifications are based upon the ASME B16.5 CL150 flange and do not include electronics.

Process fittings

Flanges are stainless steel; wetted parts are titanium. Only titanium is in contact with the process flow.

Type	Material
Sanitary fittings	304L stainless steel and titanium ASTM Grade 1
Socket-weld flanges	F316/316L stainless steel and titanium ASTM Grade 5 (6AL-4V)

Non-wetted part materials

Component	Enclosure rating	316L stainless steel	304L stainless steel	Polyurethane-painted aluminum
Sensor housing	NEMA 4X (IP66)		•	
Core processor housing	NEMA 4X (IP66/67)	•		•
Junction box housing	NEMA 4X (IP66/67)	•		•
1700/2700 transmitter housing	NEMA 4X (IP66/67)	•		•
3700 transmitter housing	NEMA 4X (IP66/67)			•

Dimensions

These dimensional drawings are intended to provide a basic guideline for sizing and planning. For complete and detailed dimensional drawings, see the product drawings link at www.emerson.com/flowmeasurement.

Note

- All dimensions are ± 0.12 in (± 3.0 mm).
- Models used for example dimensions: 32 Ra (0.8 μ m) surface finish ASME Class 150 flange painted aluminum integral core processor

Example dimensions

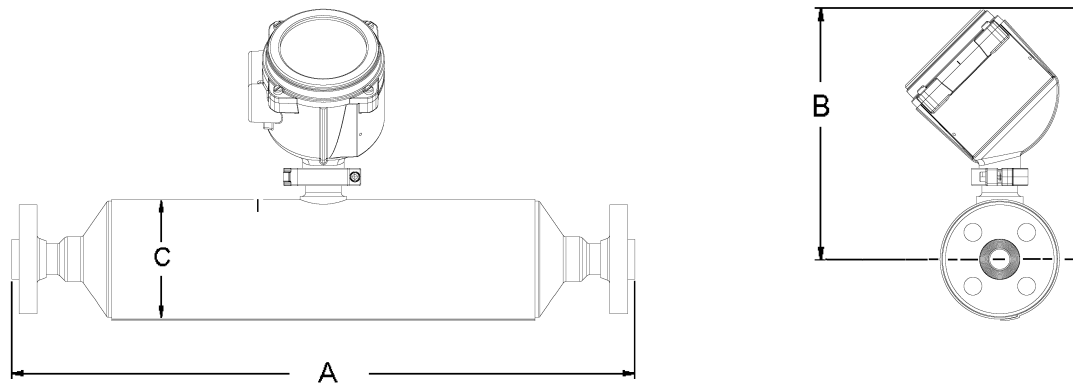

Model	Flange size	Dim. A	Dim. B	Dim. C
T025	0.5 in (13 mm)	13.31 in (338 mm)	8.06 in (205 mm)	3.11 in (79 mm)
T050	0.5 in (13 mm)	15.75 in (400 mm)	8.06 in (205 mm)	3.11 in (79 mm)
T075	1 in (25 mm)	21.06 in (535 mm)	8.61 in (219 mm)	4.13 in (105 mm)
T100	1 in (25 mm)	25.5 in (648 mm)	9.12 in (232 mm)	5.12 in (130 mm)
T150	1.5 in (38 mm)	31.46 in (799 mm)	10.10 in (257 mm)	7.13 in (181 mm)

Ordering information

Use this section to select the correct ordering codes for your configuration.

Base model

Standard sensor models

Code	Description
T025T	Micro Motion Coriolis T-Series sensor; 0.25 in (6.4 mm); straight tube; titanium; 32 Ra (0.8 μm) surface finish
T050T	Micro Motion Coriolis T-Series sensor; 0.5 in (13 mm); straight tube; titanium; 32 Ra (0.8 μm) surface finish
T075T	Micro Motion Coriolis T-Series sensor; 0.75 in (19.0 mm); straight tube; titanium; 32 Ra (0.8 μm) surface finish
T100T	Micro Motion Coriolis T-Series sensor; 1 in (25 mm); straight tube; titanium; 32 Ra (0.8 μm) surface finish
T150T	Micro Motion Coriolis T-Series sensor; 1.5 in (38 mm); straight tube; titanium; 32 Ra (0.8 μm) surface finish

Improved surface sensor models

Code	Description
T025F	Micro Motion Coriolis T-Series sensor; 0.25 in (6.4 mm); straight tube; titanium; 15 Ra (0.38 μm) surface finish
T050F	Micro Motion Coriolis T-Series sensor; 0.5 in (13 mm); straight tube; titanium; 15 Ra (0.38 μm) surface finish
T075F	Micro Motion Coriolis T-Series sensor; 0.75 in (19.0 mm); straight tube; titanium; 15 Ra (0.38 μm) surface finish

Code	Description
T100F	Micro Motion Coriolis T-Series sensor; 1 in (25 mm); straight tube; titanium; 15 Ra (0.38 μ m) surface finish
T150F	Micro Motion Coriolis T-Series sensor; 1.5 in (38 mm); straight tube; titanium; 15 Ra (0.38 μ m) surface finish

Process connections

Model T025T

Code	Description					
525	DN15	PN40	EN 1092-1	F316/F316L	Weld neck flange	Form B1
526	DN15	PN100	EN 1092-1	F316/F316L	Weld neck flange	Form B2
613	0.5 in	CL150	ASME B16.5	F316/F316L	Socket weld flange	Raised face
614	0.5 in	CL300	ASME B16.5	F316/F316L	Socket weld flange	Raised face
615	0.5 in	CL600	ASME B16.5	F316/F316L	Socket weld flange	Raised face
616	DN15	PN40	DIN 2526	F316/F316L	Socket weld flange	Type C face
617	DN15	PN100	DIN 2526	F316/F316L	Socket weld flange	Type E face
621	0.5 in		Tri-Clamp [®] compatible	Ti grade 1 clad to 304L backing	Hygienic fitting	
636	#8		VCO	Ti grade 1 clad to 304L backing	Swagelok compatible fitting	316/316L 1/2 in NPT female adapter
637	#8		VCO	Ti grade 1 clad to 304L backing	Swagelok compatible fitting	
650	DN15	PN40	DIN 2512	F316/F316L	Socket weld flange	Type N grooved face
654	DN15	PN40	EN 1092-1	F316/F316L	Weld neck flange	Form D
670	DN10		DIN11851	Ti grade 1 clad to 304L backing	Hygienic coupling	
671	DN15		DIN11851	Ti grade 1 clad to 304L backing	Hygienic coupling	
676	DN15		DIN11864-1A	Ti grade 1 clad to 304L backing	Hygienic coupling	
781	15 mm	20K	JIS B 2220	F316/F316L	Socket weld flange	

Model T025F

Code	Description					
621	0.5 in		Tri-Clamp compatible	Ti grade 1 clad to 304L backing	Hygienic fitting	
670	DN10		DIN11851	Ti grade 1 clad to 304L backing	Hygienic coupling	

Code	Description					
671	DN15		DIN11851	Ti grade 1 clad to 304L backing	Hygienic coupling	
676	DN15		DIN11864-1A	Ti grade 1 clad to 304L backing	Hygienic coupling	

Model T050T

Code	Description					
525	DN15	PN40	EN 1092-1	F316/F316L	Weld neck flange	Form B1
526	DN15	PN100	EN 1092-1	F316/F316L	Weld neck flange	Form B2
613	0.5 in	CL150	ASME B16.5	F316/F316L	Socket weld flange	Raised face
614	0.5 in	CL300	ASME B16.5	F316/F316L	Socket weld flange	Raised face
615	0.5 in	CL600	ASME B16.5	F316/F316L	Socket weld flange	Raised face
616	DN15	PN40	DIN 2526	F316/F316L	Socket weld flange	Type C face
617	DN15	PN100	DIN 2526	F316/F316L	Socket weld flange	Type E face
621	0.5 in		Tri-Clamp compatible	Ti grade 1 clad to 304L backing	Hygienic fitting	
638	#12		VCO	Ti grade 1 clad to 304L backing	Swagelok compatible fitting	316/316L 3/4 in NPT female adapter
639	#12		VCO	Ti grade 1 clad to 304L backing	Swagelok compatible fitting	
650	DN15	PN40	DIN 2512	F316/F316L	Socket weld flange	Type N grooved face
654	DN15	PN40	EN 1092-1	F316/F316L	Weld neck flange	Form D
671	DN15		DIN11851	Ti grade 1 clad to 304L backing	Hygienic coupling	
676	DN15		DIN11864-1A	Ti grade 1 clad to 304L backing	Hygienic coupling	
781	15mm	20K	JIS B 2220	F316/F316L	Socket weld flange	

Model T050F

Code	Description					
621	0.5 in		Tri-Clamp compatible	Ti grade 1 clad to 304L backing	Hygienic fitting	
671	DN15		DIN11851	Ti grade 1 clad to 304L backing	Hygienic coupling	
676	DN15		DIN11864-1A	Ti grade 1 clad to 304L backing	Hygienic coupling	

Model T075T

Code	Description					
525	DN15	PN40	EN 1092-1	F316/F316L	Weld neck flange	Form B1
526	DN15	PN100	EN 1092-1	F316/F316L	Weld neck flange	Form B2
527	DN25	PN40	EN 1092-1	F316/F316L	Weld neck flange	Form B1
528	DN25	PN100	EN 1092-1	F316/F316L	Weld neck flange	Form B2
613	0.5 in	CL150	ASME B16.5	F316/F316L	Socket weld flange	Raised face
614	0.5 in	CL300	ASME B16.5	F316/F316L	Socket weld flange	Raised face
615	0.5 in	CL600	ASME B16.5	F316/F316L	Socket weld flange	Raised face
616	DN15	PN40	DIN 2526	F316/F316L	Socket weld flange	Type C face
617	DN15	PN100	DIN 2526	F316/F316L	Socket weld flange	Type E face
618	DN25	PN40	DIN 2526	F316/F316L	Socket weld flange	Type C face
619	DN25	PN100	DIN 2526	F316/F316L	Socket weld flange	Type E face
622	0.75 in		Tri-Clamp compatible	Ti grade 1 clad to 304L backing	Hygienic fitting	
623	1 in		Tri-Clamp compatible	Ti grade 1 clad to 304L backing	Hygienic fitting	
628	1 in	CL150	ASME B16.5	F316/F316L	Socket weld flange	Raised face
629	1 in	CL300	ASME B16.5	F316/F316L	Socket weld flange	Raised face
630	1 in	CL600	ASME B16.5	F316/F316L	Socket weld flange	Raised face
650	DN15	PN40	DIN 2512	F316/F316L	Socket weld flange	Type N grooved face
651	DN25	PN40	DIN 2512	F316/F316L	Socket weld flange	Type N grooved face
654	DN15	PN40	EN 1092-1	F316/F316L	Weld neck flange	Form D
655	DN25	PN40	EN 1092-1	F316/F316L	Weld neck flange	Form D
662	DN25		ISO 2853 (IDF)	Ti grade 1 clad to 304L backing	Hygienic coupling	
672	DN25		DIN11851	Ti grade 1 clad to 304L backing	Hygienic coupling	
677	DN25		DIN11864-1A	Ti grade 1 clad to 304L backing	Hygienic coupling	
692	DN25		SMS 1145	Ti grade 1 clad to 304L backing	Hygienic coupling	
781	15 mm	20K	JIS B 2220	F316/F316L	Socket weld flange	
782	25 mm	20K	JIS B 2220	F316/F316L	Socket weld flange	

Model T075F

Code	Description					
613	0.5 in	CL150	ASME B16.5	F316/F316L	Socket weld flange	Raised face
614	0.5 in	CL300	ASME B16.5	F316/F316L	Socket weld flange	Raised face

Code	Description					
615	0.5 in	CL600	ASME B16.5	F316/F316L	Socket weld flange	Raised face
616	DN15	PN40	DIN 2526	F316/F316L	Socket weld flange	Type C face
617	DN15	PN100	DIN 2526	F316/F316L	Socket weld flange	Type E face
618	DN25	PN40	DIN 2526	F316/F316L	Socket weld flange	Type C face
619	DN25	PN100	DIN 2526	F316/F316L	Socket weld flange	Type E face
622	0.75 in		Tri-Clamp compatible	Ti grade 1 clad to 304L backing	Hygienic fitting	
623	1 in		Tri-Clamp compatible	Ti grade 1 clad to 304L backing	Hygienic fitting	
628	1 in	CL150	ASME B16.5	F316/F316L	Socket weld flange	Raised face
629	1 in	CL300	ASME B16.5	F316/F316L	Socket weld flange	Raised face
630	1 in	CL600	ASME B16.5	F316/F316L	Socket weld flange	Raised face
650	DN15	PN40	DIN 2512	F316/F316L	Socket weld flange	Type N grooved face
651	DN25	PN40	DIN 2512	F316/F316L	Socket weld flange	Type N grooved face
662	DN25		ISO 2853 (IDF)	Ti grade 1 clad to 304L backing	Hygienic coupling	
672	DN25		DIN11851	Ti grade 1 clad to 304L backing	Hygienic coupling	
677	DN25		DIN11864-1A	Ti grade 1 clad to 304L backing	Hygienic coupling	
692	DN25		SMS 1145	Ti grade 1 clad to 304L backing	Hygienic coupling	
781	15 mm	20K	JIS B 2220	F316/F316L	Socket weld flange	
782	25 mm	20K	JIS B 2220	F316/F316L	Socket weld flange	

Model T100T

Code	Description					
527	DN25	PN40	EN 1092-1	F316/F316L	Weld neck flange	Form B1
528	DN25	PN100	EN 1092-1	F316/F316L	Weld neck flange	Form B2
618	DN25	PN40	DIN 2526	F316/F316L	Socket weld flange	Type C face
619	DN25	PN100	DIN 2526	F316/F316L	Socket weld flange	Type E face
623	1 in		Tri-Clamp compatible	Ti grade 1 clad to 304L backing	Hygienic fitting	
624	1.5 in		Tri-Clamp compatible	Ti grade 1 clad to 304L backing	Hygienic fitting	
628	1 in	CL150	ASME B16.5	F316/F316L	Socket weld flange	Raised face
629	1 in	CL300	ASME B16.5	F316/F316L	Socket weld flange	Raised face
630	1 in	CL600	ASME B16.5	F316/F316L	Socket weld flange	Raised face
641	1.5 in	CL150	ASME B16.5	F316/F316L	Socket weld flange	Raised face

Code	Description					
642	1.5 in	CL300	ASME B16.5	F316/F316L	Socket weld flange	Raised face
643	1.5 in	CL600	ASME B16.5	F316/F316L	Socket weld flange	Raised face
651	DN25	PN40	DIN 2512	F316/F316L	Socket weld flange	Type N grooved face
652	DN40	PN40	DIN 2512	F316/F316L	Socket weld flange	Type N grooved face
655	DN25	PN40	EN 1092-1	F316/F316L	Weld neck flange	Form D
656	DN40	PN40	EN 1092-1	F316/F316L	Weld neck flange	Form D
658	DN40	PN40	EN 1092-1	F316/F316L	Weld neck flange	Form B1
659	DN40	PN100	EN 1092-1	F316/F316L	Weld neck flange	Form B2
672	DN25		DIN11851	Ti grade 1 clad to 304L backing	Hygienic coupling	
677	DN25		DIN11864-1A	Ti grade 1 clad to 304L backing	Hygienic coupling	
681	DN40	PN40	DIN 2526	F316/F316L	Socket weld flange	Type C face
682	DN40	PN100	DIN 2526	F316/F316L	Socket weld flange	Type E face
782	25 mm	20K	JIS B 2220	F316/F316L	Socket weld flange	
783	40 mm	20K	JIS B 2220	F316/F316L	Socket weld flange	

Model T100F

Code	Description					
618	DN25	PN40	DIN 2526	F316/F316L	Socket weld flange	Type C face
619	DN25	PN100	DIN 2526	F316/F316L	Socket weld flange	Type E face
623	1 in		Tri-Clamp compatible	Ti grade 1 clad to 304L backing	Hygienic fitting	
624	1.5 in		Tri-Clamp compatible	Ti grade 1 clad to 304L backing	Hygienic fitting	
628	1 in	CL150	ASME B16.5	F316/F316L	Socket weld flange	Raised face
629	1 in	CL300	ASME B16.5	F316/F316L	Socket weld flange	Raised face
630	1 in	CL600	ASME B16.5	F316/F316L	Socket weld flange	Raised face
641	1.5 in	CL150	ASME B16.5	F316/F316L	Socket weld flange	Raised face
642	1.5 in	CL300	ASME B16.5	F316/F316L	Socket weld flange	Raised face
651	DN25	PN40	DIN 2512	F316/F316L	Socket weld flange	Type N grooved face
652	DN40	PN40	DIN 2512	F316/F316L	Socket weld flange	Type N grooved face
672	DN25		DIN11851	Ti grade 1 clad to 304L backing	Hygienic coupling	
677	DN25		DIN11864-1A	Ti grade 1 clad to 304L backing	Hygienic coupling	
681	DN40	PN40	DIN 2526	F316/F316L	Socket weld flange	Type C face
682	DN40	PN100	DIN 2526	F316/F316L	Socket weld flange	Type E face

Code	Description					
782	25 mm	20K	JIS B 2220	F316/F316L	Socket weld flange	
783	40 mm	20K	JIS B 2220	F316/F316L	Socket weld flange	

Model T150T

Code	Description					
624	1.5 in		Tri-Clamp compatible	Ti grade 1 clad to 304L backing	Hygienic fitting	
625	2 in		Tri-Clamp compatible	Ti grade 1 clad to 304L backing	Hygienic fitting	
641	1.5 in	CL150	ASME B16.5	F316/F316L	Socket weld flange	Raised face
642	1.5 in	CL300	ASME B16.5	F316/F316L	Socket weld flange	Raised face
643	1.5 in	CL600	ASME B16.5	F316/F316L	Socket weld flange	Raised face
644	2 in	CL150	ASME B16.5	F316/F316L	Socket weld flange	Raised face
645	2 in	CL300	ASME B16.5	F316/F316L	Socket weld flange	Raised face
646	2 in	CL600	ASME B16.5	F316/F316L	Socket weld flange	Raised face
652	DN40	PN40	DIN 2512	F316/F316L	Socket weld flange	Type N grooved face
653	DN50	PN40	DIN 2512	F316/F316L	Socket weld flange	Type N grooved face
656	DN40	PN40	EN 1092-1	F316/F316L	Weld neck flange	Form D
657	DN50	PN40	EN 1092-1	F316/F316L	Weld neck flange	Form D
658	DN40	PN40	EN 1092-1	F316/F316L	Weld neck flange	Form B1
659	DN40	PN100	EN 1092-1	F316/F316L	Weld neck flange	Form B2
660	DN50	PN40	EN 1092-1	F316/F316L	Weld neck flange	Form B1
661	DN50	PN100	EN 1092-1	F316/F316L	Weld neck flange	Form B2
663	DN51		ISO 2853 (IDF)	Ti grade 1 clad to 304L backing	Hygienic coupling	
673	DN40		DIN11851	Ti grade 1 clad to 304L backing	Hygienic coupling	
674	DN50		DIN11851	Ti grade 1 clad to 304L backing	Hygienic coupling	
678	DN50		DIN11864-1A	Ti grade 1 clad to 304L backing	Hygienic coupling	
681	DN40	PN40	DIN 2526	F316/F316L	Socket weld flange	Type C face
682	DN40	PN100	DIN 2526	F316/F316L	Socket weld flange	Type E face
683	DN50	PN40	DIN 2526	F316/F316L	Socket weld flange	Type C face
684	DN50	PN100	DIN 2526	F316/F316L	Socket weld flange	Type E face
693	DN51		SMS 1145	Ti grade 1 clad to 304L backing	Hygienic coupling	

Code	Description					
783	40 mm	20K	JIS B 2220	F316/F316L	Socket weld flange	
784	50 mm	20K	JIS B 2220	F316/F316L	Socket weld flange	

Model T150F

Code	Description					
624	1.5 in		Tri-Clamp compatible	Ti grade 1 clad to 304L backing	Hygienic fitting	
625	2 in		Tri-Clamp compatible	Ti grade 1 clad to 304L backing	Hygienic fitting	
641	1.5 in	CL150	ASME B16.5	F316/F316L	Socket weld flange	Raised face
642	1.5 in	CL300	ASME B16.5	F316/F316L	Socket weld flange	Raised face
643	1.5 in	CL600	ASME B16.5	F316/F316L	Socket weld flange	Raised face
644	2 in	CL150	ASME B16.5	F316/F316L	Socket weld flange	Raised face
645	2 in	CL300	ASME B16.5	F316/F316L	Socket weld flange	Raised face
646	2 in	CL600	ASME B16.5	F316/F316L	Socket weld flange	Raised face
652	DN40	PN40	DIN 2512	F316/F316L	Socket weld flange	Type N grooved face
653	DN50	PN40	DIN 2512	F316/F316L	Socket weld flange	Type N grooved face
663	DN51		ISO 2853 (IDF)	Ti grade 1 clad to 304L backing	Hygienic coupling	
673	DN40		DIN11851	Ti grade 1 clad to 304L backing	Hygienic coupling	
674	DN50		DIN11851	Ti grade 1 clad to 304L backing	Hygienic coupling	
678	DN50		DIN11864-1A	Ti grade 1 clad to 304L backing	Hygienic coupling	
681	DN40	PN40	DIN 2526	F316/F316L	Socket weld flange	Type C face
682	DN40	PN100	DIN 2526	F316/F316L	Socket weld flange	Type E face
683	DN50	PN40	DIN 2526	F316/F316L	Socket weld flange	Type C face
684	DN50	PN100	DIN 2526	F316/F316L	Socket weld flange	Type E face
693	DN51		SMS 1145	Ti grade 1 clad to 304L backing	Hygienic coupling	
783	40 mm	20K	JIS B 2220	F316/F316L	Socket weld flange	
784	50 mm	20K	JIS B 2220	F316/F316L	Socket weld flange	

Case options

Code	Case option
S	1,450 psig (99.97 barg) containment
P	Purge fittings (two 1/2 in NPT female); 725 psig (49.99 barg) containment; not available with sensors with improved surface finish option

Electronics interface

Code	Electronics interface
Q	4-wire polyurethane-painted aluminum integral core processor for remotely mounted transmitter with MVD™ technology
A	4-wire stainless steel integral core processor for remotely mounted transmitter with MVD technology
V	4-wire polyurethane-painted aluminum integral core processor with extended mount for remotely mounted transmitter with MVD technology
B	4-wire stainless steel integral core processor with extended mount for remotely mounted transmitter with MVD technology
C	Integrally mounted 1700 or 2700 transmitter
W ⁽¹⁾	MVDSolo™; polyurethane-painted aluminum integral core processor for direct host connection (for OEMs)
D ⁽¹⁾	MVDSolo; stainless steel integral core processor for direct host connection (for OEMs)
Y ⁽¹⁾	MVDSolo; extended mount polyurethane-painted aluminum integral core processor (for OEMs)
E ⁽¹⁾	MVDSolo, extended mount stainless steel integral core processor (for OEMs)
R	9-wire polyurethane-painted junction box; not available with T025 or T050
H	9-wire polyurethane-painted junction box with extended mount; not available with T025 or T050
0	For integral mount 2400S transmitter
1	For extended integral mount 2400S transmitter
2	4-wire polyurethane-painted aluminum integral enhanced core processor for remote mount transmitters
3	4-wire stainless steel integral enhanced core processor for remote mount transmitters
4	4-wire extended polyurethane-painted aluminum enhanced core processor for remote mount transmitters
5	4-wire extended stainless steel enhanced core processor for remote mount transmitters
6	MVD Solo; polyurethane-painted aluminum integral enhanced core processor (for OEMs)
7	MVD Solo; stainless steel integral enhanced core processor (for OEMs)
8	MVD Solo; extended mount polyurethane-painted aluminum integral enhanced core processor (for OEMs)
9	MVD Solo; extended mount stainless steel enhanced core processor (for OEMs)
L	For integral mount standard finish FMT Filling transmitter
K	For integral mount improved surface finish 64Ra (1.6 µm) FMT Filling transmitter
F	For integral mount 5700 transmitter

Code	Electronics interface
Z	Other Electronic Interface - Requires a selection from the Other Electronic Interface section of the 'Certificate, Tests, Calibrations and Services' model code options

(1) When electronics interface W, D, Y or E is ordered with approval U, C, A, Z, I, G with country specific approval R1, B1 MVD Direct Connect™ I.S. barrier is supplied.

Conduit connections

Code	Conduit connection	Available with electronics interface codes						
		Q, A, V, B	W, D, Y, E	R, H	C	0, 1, F, Z	2, 3, 4, 5	6, 7, 8, 9
B ⁽¹⁾	1/2 in NPT; no gland	•	•				•	•
E ⁽²⁾	M20; no gland	•	•				•	•
F ⁽¹⁾	Brass/nickel cable gland; cable diameter 0.335 in (8.51 mm) to 0.394 in (10.01 mm)	•	•				•	•
G ⁽¹⁾	Stainless steel cable gland; cable diameter 0.335 in (8.51 mm) to 0.394 in (10.01 mm)	•	•				•	•
K ⁽³⁾	JIS B0202 1/2G; no gland	•					•	
L ⁽³⁾	Japan - brass nickel cable gland	•					•	
M ⁽³⁾	Japan - stainless cable gland	•					•	
A	3/4 in NPT; no gland			•				
A	No gland				•	•		
H ⁽¹⁾	3/4 in NPT with brass/nickel cable gland			•				
J ⁽¹⁾	3/4 in NPT; stainless steel cable gland			•				
N ⁽³⁾	JIS B0202 3/4G - no gland			•				
O ⁽³⁾	Japan - brass nickel cable gland			•				
P ⁽³⁾	Japan - stainless cable gland			•				

(1) Not available with approval code T or J.

(2) Not available with electronics interface Q, A, V, B in combination with Approval T.

(3) Only available with approval codes M or T.

Approvals

Code	Case option	Available with electronics interface codes						
		Q, A, V, B, R, H	W, D, Y, E, 6, 7, 8, 9 ⁽¹⁾	C	F, Z	0, 1	2, 3, 4, 5	K, L (Integral mount FMT)
M	Micro Motion Standard; no approval, without CE/EAC markings	•	•	•	•	•	•	•
N	Micro Motion Standard / PED compliant; with CE/EAC markings	•	•	•	•	•	•	•
U	UL	•	•	•				
C	CSA (Canada only)	•	•	•				
A	CSA (US and Canada): Class I, Division 1, Groups C and D	•	•	•	•		•	
Z	ATEX - Equipment Category 2 (Zone 1) / PED compliant	•	•	•	•		•	
I	IECEX Zone 1	•	•	•	•		•	
P	NEPSI				•		•	
T	TIIS - T4 Temperature Classification; not available for quote outside Japan	•		•			•	
S	TIIS - T3 Temperature Classification; not available for quote outside Japan						•	
L	TIIS - T2 Temperature Classification; not available for quote outside Japan						•	
J	Hardware ready for TIIS approval; EPM Japan only	•		•	•		•	
V	ATEX (Zone 2) / PED compliant			•	•	•		•
3	IECEX (Zone 2)			•	•	•		•
2	CSA (US and Canada): Class I, Division 2, Groups A, B, C, D			•	•	•		•
G	Country Specific Approval – Requires a selection from Country specific approvals	•	•	•	•	•	•	•

(1) When electronics interface W, D, Y, E, 6, 7, 8 or 9 is ordered with approval U, C, A, Z, I, G with country specific approval R1, B1 MVD Direct Connect I.S. barrier is supplied.

Languages

Code	Language option
A	Danish CE requirements document and English installation manual
D	Dutch CE requirements document and English installation manual
E	English installation manual
F	French installation manual

Code	Language option
G	German installation manual
H	Finnish CE requirements document and English installation manual
I	Italian installation manual
J	Japanese installation manual
M	Chinese installation manual
N	Norwegian CE requirements document and English installation manual
P	Portuguese installation manual
Q	Korean installation manual
S	Spanish installation manual
W	Swedish CE requirements document and English installation manual
B	Hungarian CE requirements document and English installation manual
K	Slovak CE requirements document and English installation manual
T	Estonian CE requirements document and English installation manual
U	Greek CE requirements document and English installation manual
L	Latvian CE requirements document and English installation manual
V	Lithuanian CE requirements document and English installation manual
Y	Slovenian CE requirements document and English installation manual

Future option 1

Code	Future option 1
Z	Reserved for future use

Future option 2

Code	Additional standard approvals
Z	Reserved for future use

Calibration options

Code	Calibration option
Z	$\pm 0.15\%$ mass flow and 0.002 g/cm^3 (2 kg/m^3) density calibration ($\pm 0.25\%$ volume flow)
1	$\pm 0.10\%$ mass flow and 0.001 g/cm^3 (1 kg/m^3) density calibration ($\pm 0.15\%$ volume flow) Not available on all models
K	$\pm 0.10\%$ mass flow and 0.0005 g/cm^3 (0.5 kg/m^3) density calibration ($\pm 0.15\%$ volume flow) Not available on T025 model.

Measurement application software

Code	Measurement application software option
Z	No measurement application software
A	Petroleum measurement; available with electronics interface codes W, D, Y,E, 6, 7, 8, and 9.; for all other electronics options, select the petroleum software option on the transmitter

Factory options

Code	Factory option
Z	Standard product
X	ETO product
R	Restocked product (if available)

Certificates, tests, calibrations, and services

These option codes can be added to the end of the model code if needed, but no code is required when none of these options is selected.

There may be additional options or limitations depending on total meter configuration. Contact a sales representative before making your final selections.

Material quality examination tests and certificates

Code	Factory option
MC	Material inspection certificate 3.1 (supplier lot traceability per EN 10204)

Pressure testing

Select any from this group.

Code	Factory option
HT	Hydrostatic test certificate 3.1 (wetted components only)
PN	Pneumatic test certificate 3.1

Dye penetrant examination

Select any from this group.

Code	Factory option
D1	Dye penetrant test package 3.1; process connection only; liquid dye penetration NDE qualification
D2	Dye penetrant test package 3.1; case only; liquid dye penetration NDE qualification

Weld examination

Code	Factory option
WP	Weld procedure package (weld map, weld procedure specification, weld procedure qualification record, welder performance qualification)

Special cleaning

Code	Factory option
O2	Declaration of compliance oxygen service 2.1

Accredited calibration

Code	Factory option
IC	ISO17025 accredited calibration and certificates (9 points total)

Special calibration options

Select either none, CV, or CV with one of the additional verification point options.

Minimum flow rates may apply when selecting the special calibration option.

Code	Factory option
CV	Custom verification (alter original verification points)
01	Add 1 additional verification point
02	Add 2 additional verification point
03	Add 3 additional verification point
06	Add up to 6 additional verification points
08	Add up to 8 additional verification points
16	Add up to 16 additional verification points

Sensor completion

Select any from this group.

Code	Factory option
WG	Witness general
SP	Special packaging

Country specific approvals

Select one from the following if approval code G is selected.

Code	Factory option
R1	EAC Zone 1 – Hazardous Approval
B1	INMETRO Zone 1 – Hazardous Approval

Other electronic interface

Select one if electronic interface option Z is selected.

Code	Factory option
UA	4200 integral mount aluminum housing

Emerson Automation Solutions

Worldwide Headquarters
7070 Winchester Circle
Boulder, Colorado USA 80301
T: +1 800-522-6277
T: +1 303-527-5200
F: +1 303-530-8459
Mexico: 52 55 5809 5473
Argentina: 54 11 4733 5400
Brazil: 55 15 3413 8888
Chile: 56 22 4310 7432

Emerson Automation Solutions

Central Europe: +41 41 7686 111
Eastern Europe: +41 41 7686 111
Dubai: +971 4 811 8100
Abu Dhabi: +971 2 697 2000
Austria: +43 2236 607-0
France: 0800 917 901
Germany: +49 (0) 2173 3348 0
Italy: 8008 77334
The Netherlands: +31 318 495 555
Belgium: +32 2 716 77 11
Spain: 900 901 986
U.K.: 0870 240 1978
Russian/CIS: +7 495 995 9559

Emerson Automation Solutions

Australia: (61) 3 9721 0200
China: (86) 21 2892 9000
India: (91) 22 6662 0566
Japan: (81) 3 5769 6803
South Korea: (82) 31 8034 0000
Singapore: (65) 6 363 7766

©2020 Micro Motion, Inc. All rights reserved.

The Emerson logo is a trademark and service mark of Emerson Electric Co. Micro Motion, ELITE, ProLink, MVD and MVD Direct Connect marks are marks of one of the Emerson Automation Solutions family of companies. All other marks are property of their respective owners.