



HygroCal100 Humidity Validator User's Manual



97500 Issue 1
September 2015

Please fill out the form(s) below for each instrument that has been purchased.

Use this information when contacting Michell Instruments for service purposes.

Instrument	
Code	
Serial Number	
Invoice Date	
Location of Instrument	
Tag No	

Instrument	
Code	
Serial Number	
Invoice Date	
Location of Instrument	
Tag No	

Instrument	
Code	
Serial Number	
Invoice Date	
Location of Instrument	
Tag No	



HygroCal100

For Michell Instruments' contact information please go to
www.michell.com

© 2015 Michell Instruments

This document is the property of Michell Instruments Ltd. and may not be copied or otherwise reproduced, communicated in any way to third parties, nor stored in any Data Processing System without the express written authorization of Michell Instruments Ltd.

Contents

Safety	vii
Electrical Safety	vii
Toxic Materials	vii
Repair and Maintenance	vii
Calibration	vii
Safety Conformity	vii
Abbreviations	viii
Warnings	viii
1 INTRODUCTION	1
1.1 Operating Principle	1
2 INSTALLATION	2
2.1 Unpacking.....	2
2.2 Operating Requirements	3
2.2.1 Environmental Requirements	3
2.2.2 Electrical Requirements	3
2.3 Exterior Layout.....	4
2.4 Rear Panel Layout	7
2.4.1 Probe Input Connections	7
2.4.2 USB Communications Port	8
2.4.3 Service Access Port	8
2.4.4 Power Adaptor Input.....	9
2.5 Top Panel Layout.....	9
2.5.1 Probe Ports.....	9
2.5.2 Desiccant Reservoir	10
2.5.3 Saturator Reservoir	10
3 OPERATION	11
3.1 General Operational Information.....	11
3.2 Display	11
3.3 Main Screen Layout	12
3.4 Menu Structure	13
3.4.1 Current Set Point	14
3.4.2 Probe Selection.....	14
3.4.3 Operational Status Display	14
3.4.4 Calibration Settings	15
3.4.4.1 Mode	15
3.4.4.2 Probes	16
3.4.4.3 Program	17
3.4.4.4 Logging.....	18
3.4.4.5 Reference Setup	20
3.4.5 System Settings	21
3.4.5.1 Display	21
3.4.5.2 Clock.....	22
3.4.5.3 About.....	23
3.4.5.4 Correct.....	23
3.4.6 Table View.....	24
3.5 Port Adaptors.....	25
3.6 Probe Installation	25
3.6.1 Chamber Connection	25
3.6.2 Electrical Connection	26
3.7 Battery Operation	27

3.8	Operating Guide	27
3.8.1	Manual Mode	27
3.8.2	Automatic Mode	28
3.9	Operating Practice	29
3.9.1	Humidity Stabilization Times	30
3.9.2	Data Logging	30
3.10	Standby Mode	30
3.11	External Reference Configuration	30
4	MAINTENANCE	31
4.1	Desiccant Reservoir	31
4.2	Saturator Reservoir	32
4.3	Replacing the Internal Reference Sensor	32
4.4	Calibration Correction	33

Tables

Table 1	Operation Mode Screen Parameters	15
Table 2	Probe Setup Screen Parameters	16
Table 3	HygroCal100 Logging Screen Parameters	18
Table 4	RH Reference Setup Screen Parameters	20
Table 5	Display Settings Screen Parameters	21
Table 6	Clock Settings Screen Parameters	22

Figures

Figure 1	Front Panel	4
Figure 2	Top Panel.....	5
Figure 3	Rear Panel	6
Figure 4	Probe Input Connections.....	7
Figure 5	USB Communications Port.....	8
Figure 6	Service Access Port.....	8
Figure 7	Power Adaptor Input	9
Figure 8	Probe Ports.....	9
Figure 9	Desiccant Reservoir	10
Figure 10	Saturator Reservoir.....	10
Figure 11	Main Screen.....	11
Figure 12	Main Screen Layout	12
Figure 13	Set Point Entry Screen	14
Figure 14	Calibration Settings Screen.....	15
Figure 15	Operation Mode Screen.....	15
Figure 16	Probe Setup Screen	16
Figure 17	Program Calibration Routine Screen	17
Figure 18	HygroCal100 Logging Screen.....	18
Figure 19	Log Files Screen	19
Figure 20	RH Reference Setup Screen.....	20
Figure 21	System Settings Screen.....	21
Figure 22	Display Settings Screen.....	21
Figure 23	Clock Settings Screen	22
Figure 24	About Screen	23
Figure 25	Calibration Correction Screen	23
Figure 26	Calibration in Progress Screen	24
Figure 27	Port Adaptor	25
Figure 28	Port Adaptor Tool	25
Figure 29	Set Point Entry Screen	27
Figure 30	Example of Calibration Routine.....	28
Figure 31	Visualization of Calibration Routine	28
Figure 32	Calibration Correction Setup Screen	33
Figure 33	Calibration Correction Screen	34

Appendices

Appendix A	Technical Specifications.....	36
Appendix B	Troubleshooting.....	38
Appendix C	EU Declaration of Conformity.....	40
Appendix D	Quality, Recycling & Warranty Information.....	42
	D.1 Pressure Equipment Directive (PED) 97/23/EC	42
	D.2 Recycling Policy	42
	D.3 WEEE Compliance.....	42
	D.4 RoHS2 Compliance	43
	D.5 Warranty.....	43
	D.6 REACH Compliance	44
	D.7 Return Policy	44
	D.8 Calibration Facilities	45
	D.9 Manufacturing Quality	45
	D.10 FCC (EMC Requirements for North America)	45
Appendix E	Return Document & Decontamination Declaration.....	47

Safety

The manufacturer has designed this equipment to be safe when operated using the procedures detailed in this manual. The user must not use this equipment for any other purpose than that stated. Do not apply values greater than the maximum value stated.

This manual contains operating and safety instructions, which must be followed to ensure the safe operation and to maintain the equipment in a safe condition. The safety instructions are either warnings or cautions issued to protect the user and the equipment from injury or damage. Use qualified personnel and good engineering practice for all procedures in this manual.

Electrical Safety

The instrument is designed to be completely safe when used with options and accessories supplied by the manufacturer for use with the instrument. The input power supply voltage is limited to 24 V DC.

Toxic Materials

The use of hazardous materials in the construction of this instrument has been minimized. During normal operation it is not possible for the user to come into contact with any hazardous substance which might be employed in the construction of the instrument. Care should, however, be exercised during maintenance and the disposal of certain parts.

Repair and Maintenance

The instrument must be maintained either by the manufacturer or an accredited service agent. Refer to www.michell.com for details of Michell Instruments' worldwide offices contact information.

Calibration

The recommended calibration interval for the HS3 control sensor is one year, unless otherwise specified by Michell Instruments Ltd. The instrument should be returned to the manufacturer, Michell Instruments, or one of their accredited service agents for re-calibration (go to www.michell.com for contact information).

Safety Conformity

This product meets the essential protection requirements of the relevant EU directives.

Abbreviations

The following abbreviations may or may not be used in this manual:

AC	alternating current
atm	pressure unit (atmosphere)
bar	pressure unit (=100 kP or 0.987 atm)
°C	degrees Celsius
°F	degrees Fahrenheit
COM	common
dp	dew point
EU	European Union
HMI	Human Machine Interface
Hz	Hertz
IEC	International Electrotechnical Commission
NI/min	normal liters per minute
lb	pound
mA	milliampere
mAh	milliampere hour
max	maximum
min	minute(s)
mV	millivolt(s)
N/C	normally closed
N/O	normally open
No	number
PRT	Platinum resistance thermometer (typically type Pt100)
psig	pound(s) per square inch (gauge)
rh	relative humidity
RTU	Remote Terminal Unit
scfh	standard cubic feet per hour
SD	storage device card (memory card for storing datalog files)
sec	second(s)
temp	temperature
USB	Universal Serial Bus
V	Volts

Warnings

The following general warnings listed below are applicable to this instrument. They are repeated in the text in the appropriate locations.



Where this hazard warning symbol appears in the following sections, it is used to indicate areas where potentially hazardous operations need to be carried out.



DANGER
Electric
Shock Risk

Where this symbol appears in the following sections it is used to indicate areas of potential risk of electric shock.

1 INTRODUCTION

The HygroCal100 Portable Humidity Validator enables quick and convenient generation of a known humidity condition at ambient temperatures.

The chamber allows seven relative humidity probes of various diameters to be installed into the chamber simultaneously. The probes can be powered directly from the HygroCal100, and monitored via the intuitive touch screen user interface.

This interface also allows the programming of a calibration profile, so that a series of humidity values can be generated and held automatically for a set time period. The readings from all probes under test and the built-in reference can also be logged for completely autonomous operation.

1.1 Operating Principle

The Validator operates on a divided flow mixing principle. The main calibration chamber is supplemented by two reservoirs, one of which contains desiccant, the other contains a saturator, which consists of a small quantity of distilled water and a diffuser.

A pump draws ambient air into the system, which is directed either to the desiccant or saturator reservoir by a 2-way valve. When flowing through the desiccant, moisture is removed from the air; when flowing through the saturator, moisture is added to almost completely saturate it at the prevailing temperature.

A Michell Instruments' Hygrosmart 3 control sensor is installed inside the calibration chamber, continually measuring the temperature and relative humidity inside. When a target humidity level is set via the user interface, the control system uses the reading of the HS3 control sensor to determine whether to add humid air or dry air to the chamber in order to reach the desired level. When the reading of the HS3 is equal to that of the target set point, the system alternates between injections of dry and wet air to maintain a constant humidity condition in the chamber.

2 INSTALLATION

2.1 Unpacking

Open the box and unpack carefully as follows

1. Remove the carry case from the packing box.



2. Open the carry case.



3. Remove the instrument and place on a level surface.

Save all the packing materials for the purpose of returning the instrument for recalibration or any warranty claims.

The carry case should contain the following items:

- Control sensor calibration certificate
- Power adaptor
- User manual
- Port adaptor tool
- Spare Port adaptors (optional)
- Desiccant and water bottles (optional)

If there are any shortages please notify Michell Instruments immediately.

If Calibration Kit 1 or 2 has been ordered, then a separate box will also be supplied containing the reference instrument (either an MDM25 or Optidew Vision). The specific port adaptors for the reference will be in the carry case with any other spare port adaptors ordered.

2.2 Operating Requirements

2.2.1 Environmental Requirements

It is important to operate the HygroCal100 within the following environmental conditions:

Minimum operating temperature	+5°C (+41°F)
Maximum operating temperature	+40°C (+104°F)
Maximum relative humidity	95%

2.2.2 Electrical Requirements

The power adaptor for the HygroCal100 requires the following electrical supply:

100 to 240 V AC, 50/60 Hz

2.3 Exterior Layout

The controls, indicators and connectors associated with the HygroCal100 are located on the front, top and rear panels of the device.

Front Panel

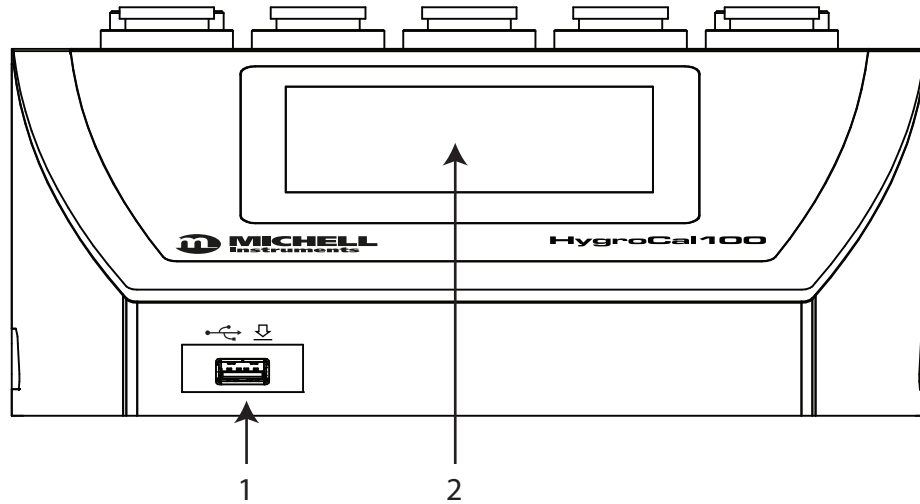

Figure 1 Front Panel

<p>1</p>	<p>USB port</p>	<p>Accepts a USB memory device for the transfer of logged data (see Section 3.4.4.4 for instructions on how to download logged data).</p>
<p>2</p>	<p>Touch screen display</p>	<p>Displays measured readings and enables the user to control the operation of the chamber.</p>

Top Panel

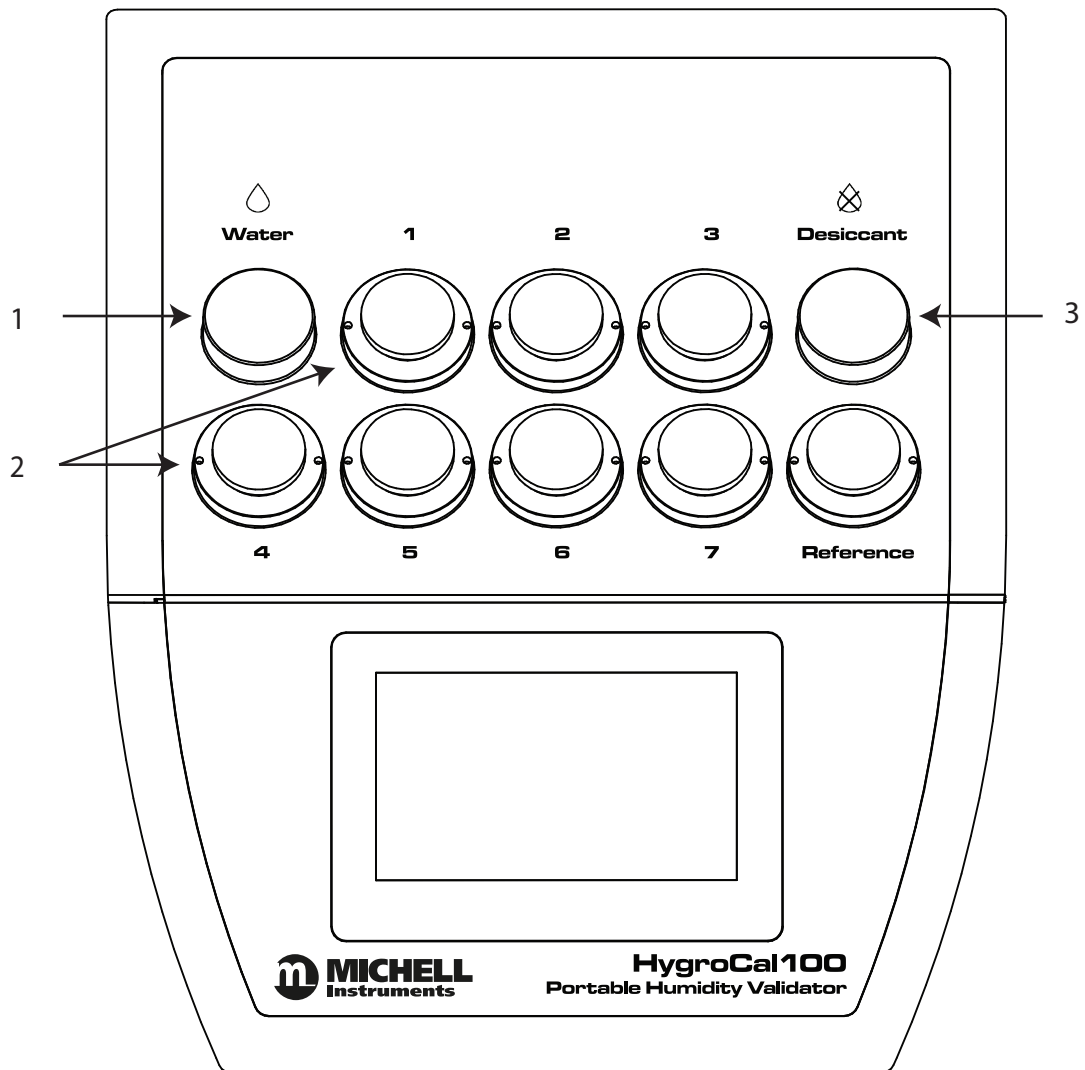

Figure 2 Top Panel

1	Saturator reservoir	Contains a diffuser and distilled water used to humidify the air in the chamber (see Section 4.2 for instructions on how to refill the saturator).
2	Probe ports	Used to mount probes under test into the chamber (see Section 2.5.1 for instructions on how to install port adaptors and probes).
3	Desiccant reservoir	Contains desiccant used to dry the air in the chamber (see Section 4.1 for instructions on how to replace desiccant).

Rear Panel

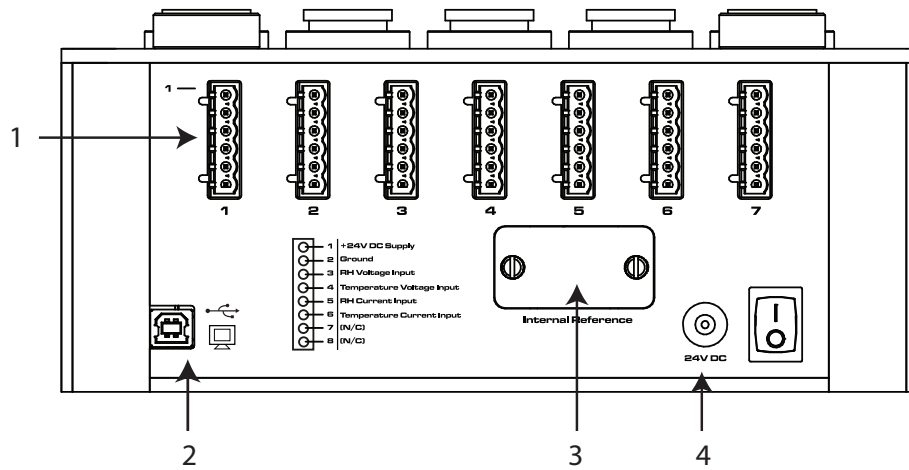

Figure 3 Rear Panel

1	Probe input connections	Connections for probes under test (see Section 2.5.1 for instructions on how to connect probes).
2	USB communications port	Allows the HygroCal to be connected to a PC, outputting the relative humidity and temperature values of both the reference probes and the probes under test.
3	Service access port	Remove for replacement of HS3 control probe (see Section 4.3 for instructions on how to replace the control probe).
4	Power adaptor input	24 V DC input.

2.4 Rear Panel Layout



These tasks should only be undertaken by qualified personnel.

Connections to the rear panel of the chamber are explained in the following sections:

2.4.1 Probe Input Connections

Seven 8-pin connectors are provided to allow connection of probes under test. Probes with a voltage or current input can be connected.

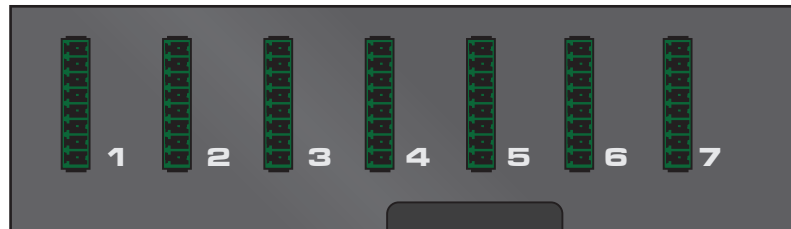

Probe Input Connector Pins	
1	+24 V DC supply
2	Ground
3	RH voltage input
4	Temperature voltage input
5	RH current input
6	Temperature current input
7	Not connected
8	Not connected

Figure 4 *Probe Input Connections*

2.4.2 USB Communications Port

The USB type-B connector on the rear panel allows the HygroCal to be connected to a PC, outputting the relative humidity and temperature values of both the reference probes and the probes under test.



Figure 5 *USB Communications Port*

When connecting the port to a PC, the device will be installed as a virtual serial port, and assigned its own COM port number, allowing communication with many different engineering programs and programming languages. The output will be in the following format:

InternalReferenceRH Probe1RH Probe2RH Probe3RH Probe4RH Probe5RH Probe6RH Probe7RH
InternalReferenceTP Probe1TP Probe2TP Probe3TP Probe4TP Probe5TP Probe6TP Probe7TP
0100 0114 FFFF 0115 FFFF FFFF FFFF FFFF 00E9 00E4 FFFF 00E3 FFFF FFFF FFFF

Each 2 byte hex word is a 16 bit unsigned integer, which should be divided by 10 to give the actual decimal value of the associated reading.

e.g. **Internal Reference RH** value **0x0100** = 256. Dividing this value by 10 gives the %RH value **25.6%**

2.4.3 Service Access Port

The service access port has a cover which can be removed to access the HS3 control sensor for replacement (see replacement instructions in Section 4.3).

The cover is held in place by two flat-head screws.



Figure 6 *Service Access Port*

2.4.4 Power Adaptor Input

The DC power connector is a push fit into the power input socket, as shown in figure X. The method of connection is as follows:

1. Ensure that both ends of the power cable are potential free, i.e. not connected to an AC power supply.
2. Check that the ON/OFF switch is switched to OFF.
3. Push the connector into the power input socket.
4. Connect the mains plug of the power adaptor to a suitable AC power source (voltage range 100 to 240 V AC, 50/60 Hz) and switch on the AC supply.
5. Switch on the instrument, as required, using the power ON switch.



Figure 7 *Power Adaptor Input*

2.5 Top Panel Layout

2.5.1 Probe Ports

Seven ports are provided for the installation of probes under test. Each port is fitted with an adaptor, which allows the probe to be sealed into the chamber by means of an O-ring.

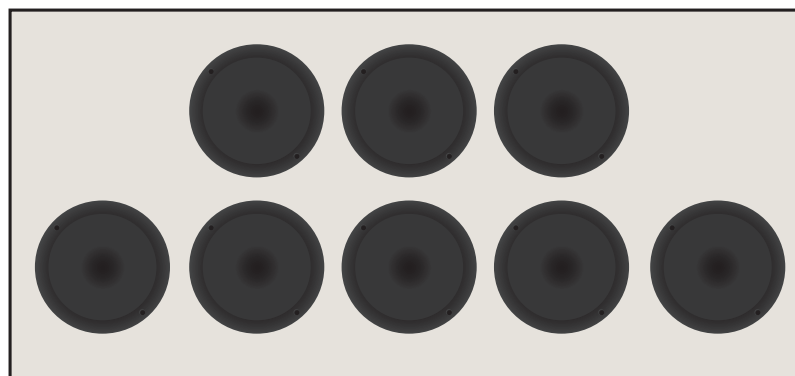

Figure 8 *Probe Ports*

Adaptors are available with a wide variety of port sizes, from 12 to 25mm.

To install a port adaptor, locate the port adaptor removal tool (A000265) in the pin holes on each adaptor, and unscrew or tighten the adaptor into the port. Take care not to crosstread the adaptors.

To install a probe, simply fit the correct size of port adaptor, remove the blanking plug, and push the probe straight through the center of the adaptor until the O-ring grips the probe shaft at its widest point. Ensure that any ports not in use are blanked off with the appropriate plug.

2.5.2 Desiccant Reservoir



Figure 9 *Desiccant Reservoir*

The desiccant reservoir should be filled with the desiccant provided before operation:

1. Remove the lid.
2. Pour in fresh desiccant until full to inside lip.
3. Re-fit the lid.

The desiccant chamber requires 25cm³ of desiccant to fill, which is approximately equivalent to filling up to the inside lip.

2.5.3 Saturator Reservoir

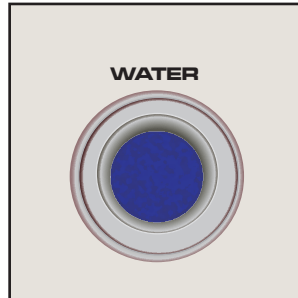

Figure 10 *Saturator Reservoir*

The saturator provides the source of humid air for the chamber.

Distilled water should be added to the saturator before operation:

1. Remove the lid.
2. Pour in 25ml distilled water.
3. Re-fit the lid.

The saturator should **only** be filled with distilled water - no more than 25ml total (refer to Section 4.2).

NOTE: Always remove water from the saturator reservoir before transportation.

3 OPERATION

Once filled with water and desiccant, the HygroCal100 is ready for operation. This section describes both the general operation of the chamber and the method of setting it up and changing the default parameters (see Section 3.4.5.4) should this become necessary.

3.1 General Operational Information

The chamber should be placed on a level surface in an environment with as stable an ambient temperature as possible. When moving the device from one place to another leave for 30 minutes to 1 hour in the new location to allow the temperature of the HygroCal100 to equilibrate with the prevailing ambient.

The HygroCal100 is suitable for verifying almost any relative humidity sensor, provided that it can be tightly sealed into the chamber.

3.2 Display

The HygroCal100 features a 4.3" colour touch screen display.

When the chamber is switched on the screen will initially be blank while the menu system loads.

After the menu system has loaded, the Main Screen will show.

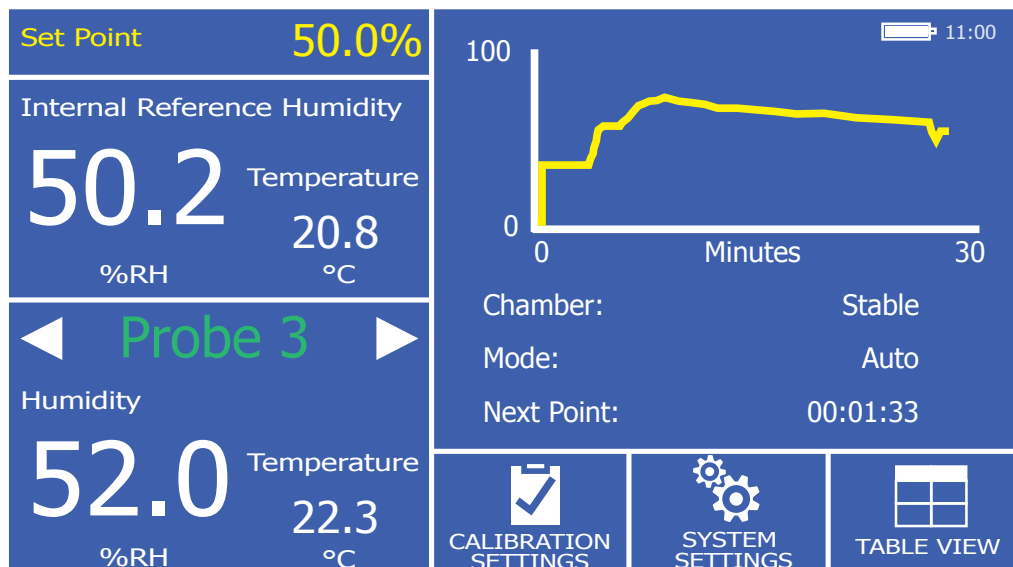

Figure 11 Main Screen

3.3 Main Screen Layout

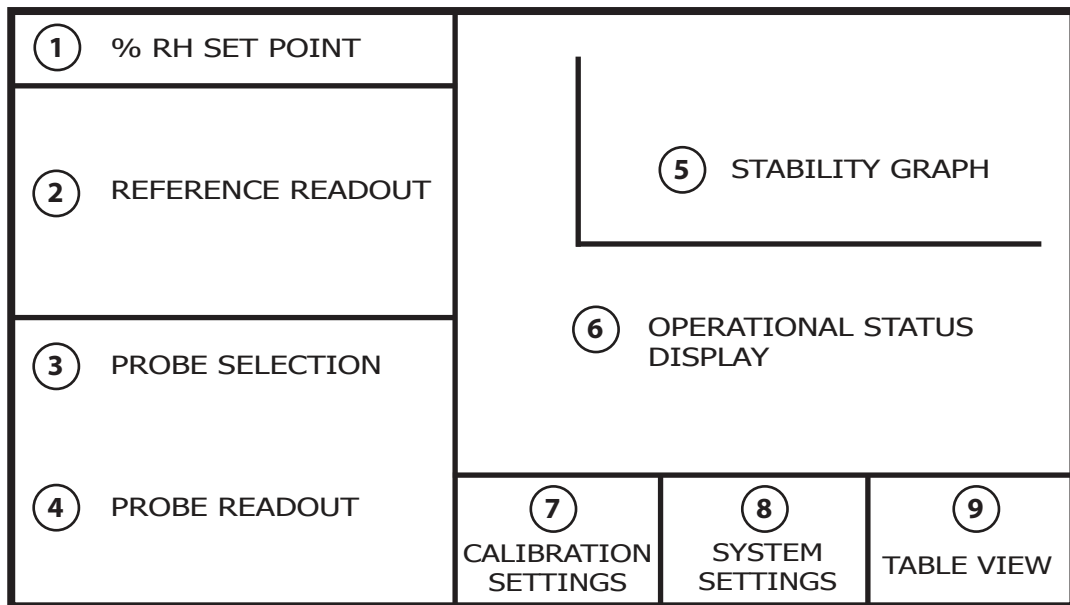
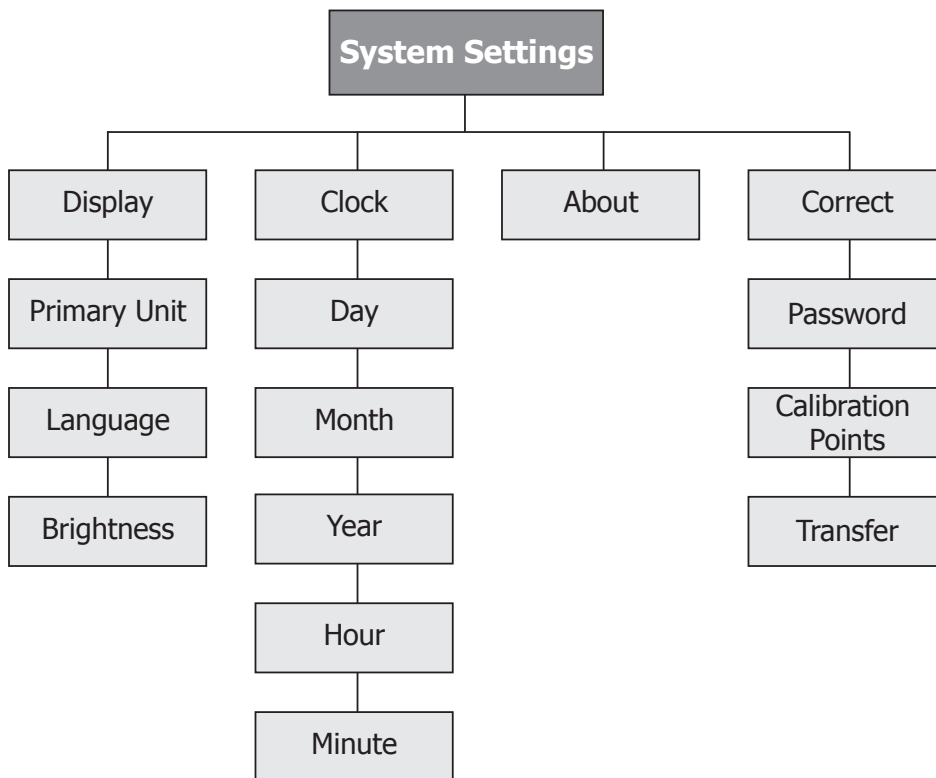
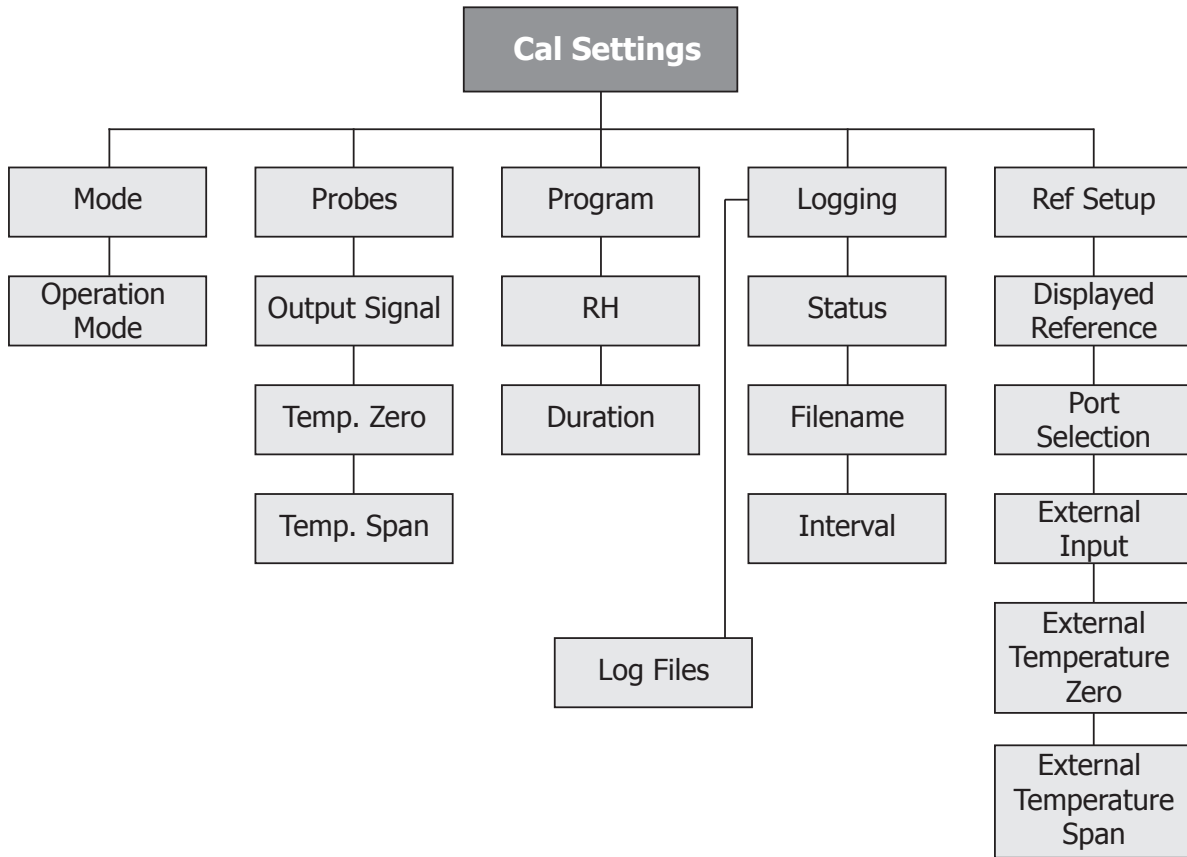

Figure 12 Main Screen Layout

1	Relative Humidity Set Point	Indicates the target RH set point. See Section 3.4.1 for additional information.
2	Reference Readout	Displays the RH and temperature readouts of the selected reference sensor.
3	Probe Selection	Switches between the currently connected probes. See Section 3.4.2 for additional information.
4	Probe Readout	Displays the RH and temperature readouts of the selected probe.
5	Stability Graph	Displays a plot of RH over time. Touch and hold the readout to enter full screen mode.
6	Operational Status Display	A detailed description of each item displayed in this area is in Section 3.4.3.
7	Calibration Settings Button	Access to the Calibration Settings Menu. See Section 3.4.4 for more information about the Calibration Settings menu.
8	System Settings Button	Access to the System Settings Menu. See Section 3.4.5 for more information about the System Settings menu.
9	Table View Button	Access to the Table View Screen. See Section 3.4.6 for more information about Table View.

3.4 Menu Structure



3.4.1 Current Set Point

The target relative humidity level can be changed by pressing the **Set Point** pane in the top left of the main screen. This is only possible when Calibration Settings -> **Mode** is set to **Manual**.

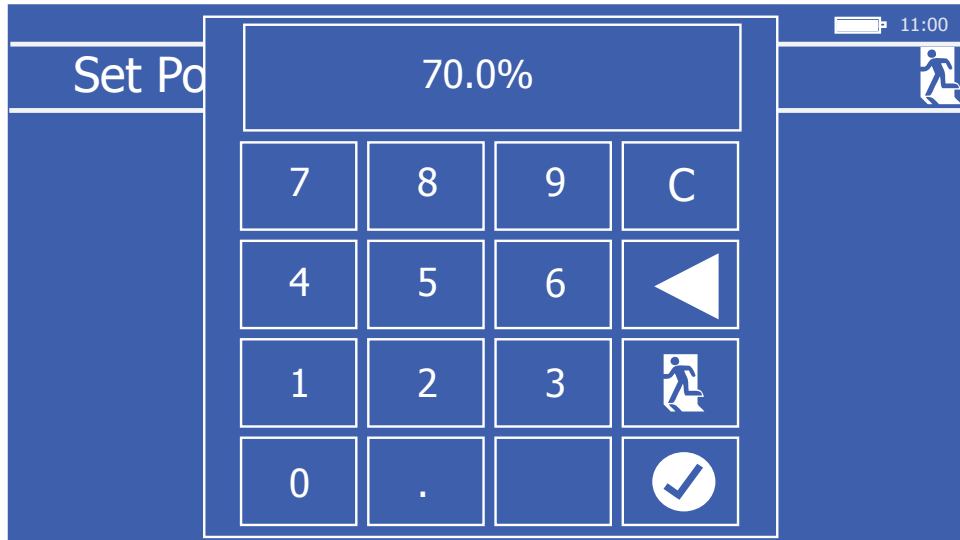

Figure 13 Set Point Entry Screen

3.4.2 Probe Selection

The probe selection pane on the Main Screen can be configured to show the relative humidity and temperature readings of any of the connected probes.

To cycle through the connected probes, touch the left or right arrow keys on either side of the probe number indication.

3.4.3 Operational Status Display

The Operational Status Display includes the following:

Chamber	Indicates the operational condition of the chamber. Options: RESPONDING, STABILIZING, STABLE or OFF
Mode	Indicates the operating mode of the chamber. Options: MANUAL, AUTO or STANDBY
Next Point	When the conditions in the chamber are stable this will indicate the time remaining until the next set point.

3.4.4 Calibration Settings

The Calibration Settings Screen is used to configure the probes under test, the calibration routine to be followed and the data logging feature.

Initially, when the Calibration Settings Screen is opened, a set of labelled icons is displayed. Touching once of these icons will take you to the appropriate submenu.

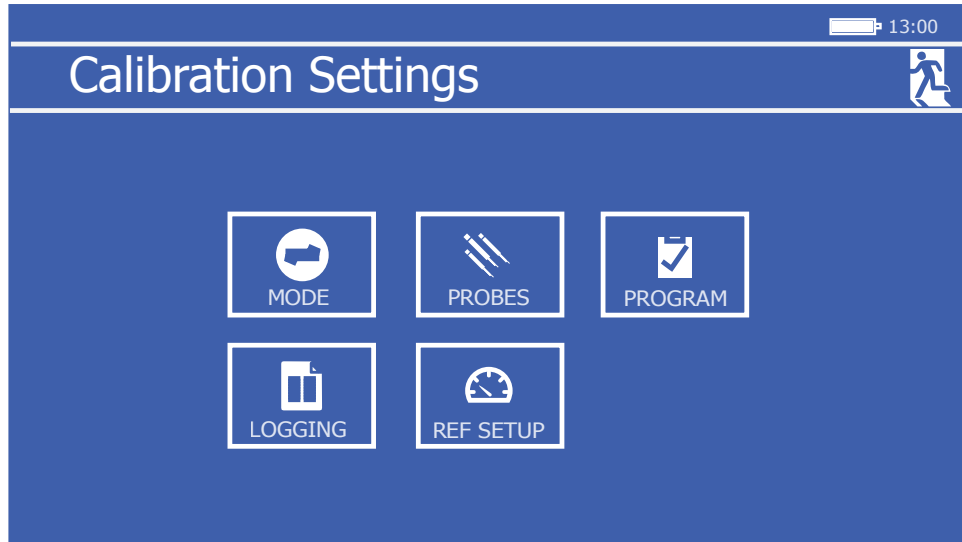

Figure 14 Calibration Settings Screen

3.4.4.1 Mode

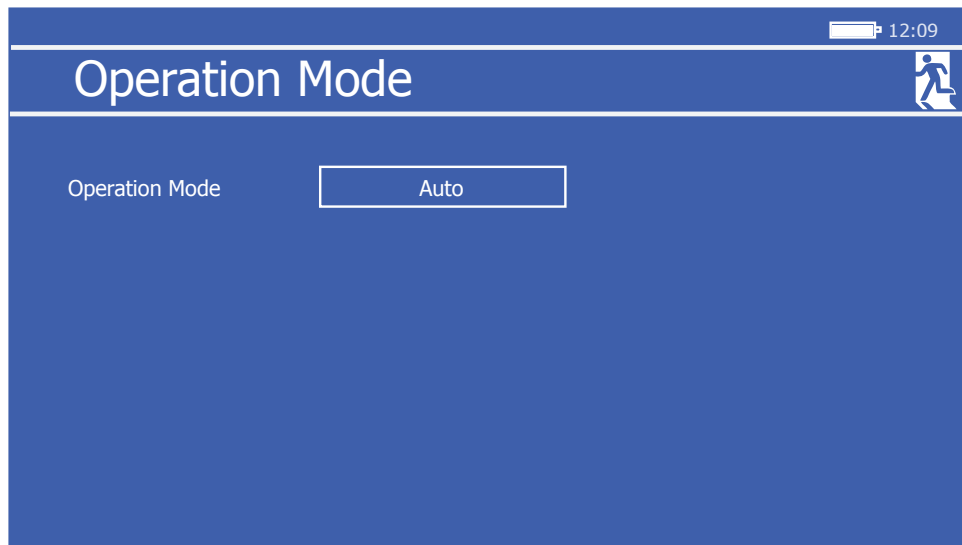

Figure 15 Operation Mode Screen

Parameter	Description
Operation Mode	Determines whether the chamber is controlling manually according to the target set point on the Main Screen, automatically according to an entered calibration routine, or remaining in standby mode. Available Input: Manual/Auto/Standby

Table 1 Operation Mode Screen Parameters

3.4.4.2 Probes

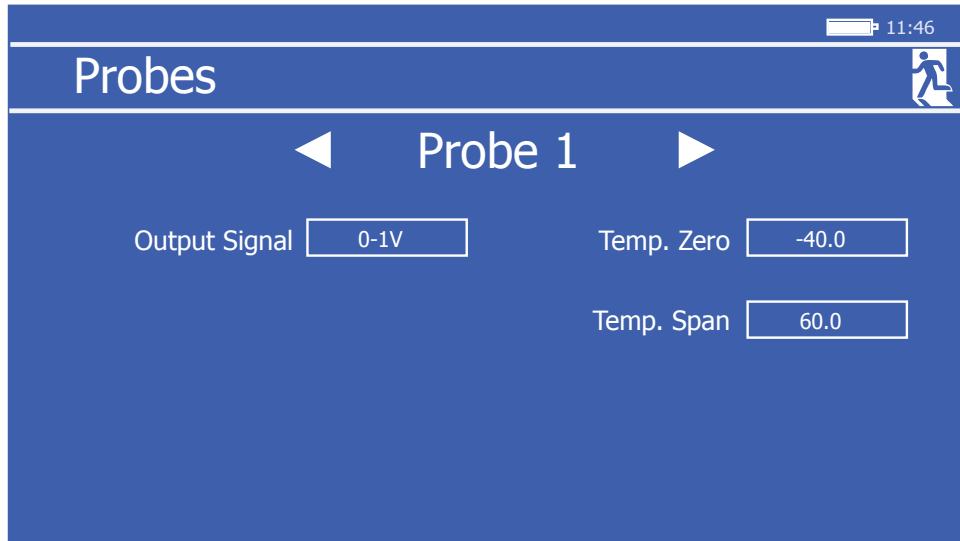

Figure 16 Probe Setup Screen

Parameter	Description
Probe #	Scrolls through the probe ports using the left and right arrows
Output Signal	The output signal used by the probe currently selected Available Input: 0-20 mA, 4-20 mA, 0-1 V, 0-5 V, 0-10 V
Temp. Zero	For this probe # - Sets the temperature which corresponds to a zero output Available Input: Numerical
Temp. Span	For this probe # - Sets the probe temperature which corresponds to a span output Available Input: Numerical

Table 2 Probe Setup Screen Parameters

3.4.4.3 Program

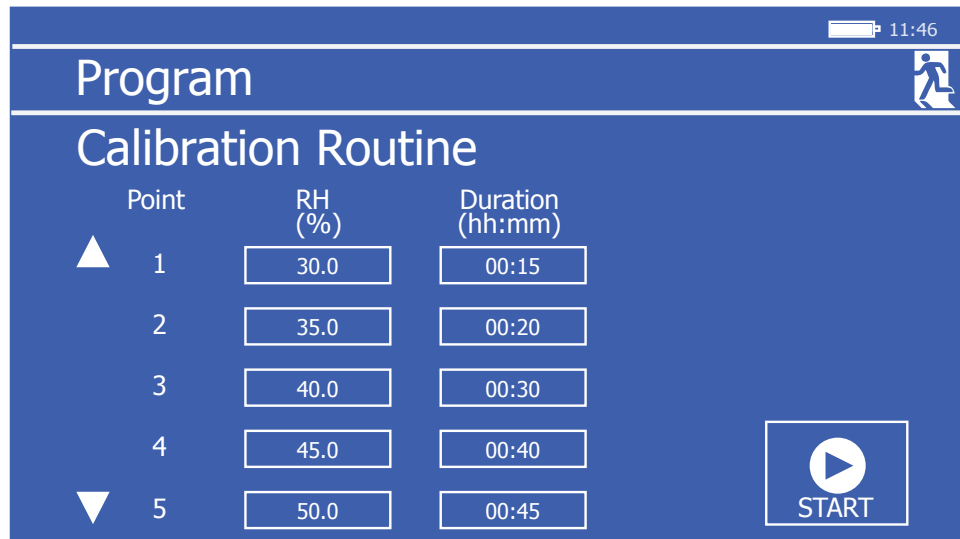

Figure 17 Program Calibration Routine Screen

The table provided in the Calibration Routine Screen allows a series of relative humidity points to be generated for set time periods without intervention by the user.

Each row of the table defines a calibration point, with fields to enter the desired relative humidity value and the length of time the chamber should spend maintaining this humidity.

Once this period of time has elapsed, the chamber will move to the conditions on the next row. There can be a maximum of 10 calibration points in the routine.

NOTE: The 'Duration' only starts when the chamber has stabilized at the desired condition.

To initiate the calibration routine, touch the **Start** button.

At this point, if logging is not in progress, then a prompt will appear to confirm whether or not logging is required.

If **NO** is selected, then the program will start and the display will return to the Main Screen.

If **YES** is selected, then the Logging Screen will be displayed. Once data logging has been initiated the program will run.

3.4.4.4 Logging

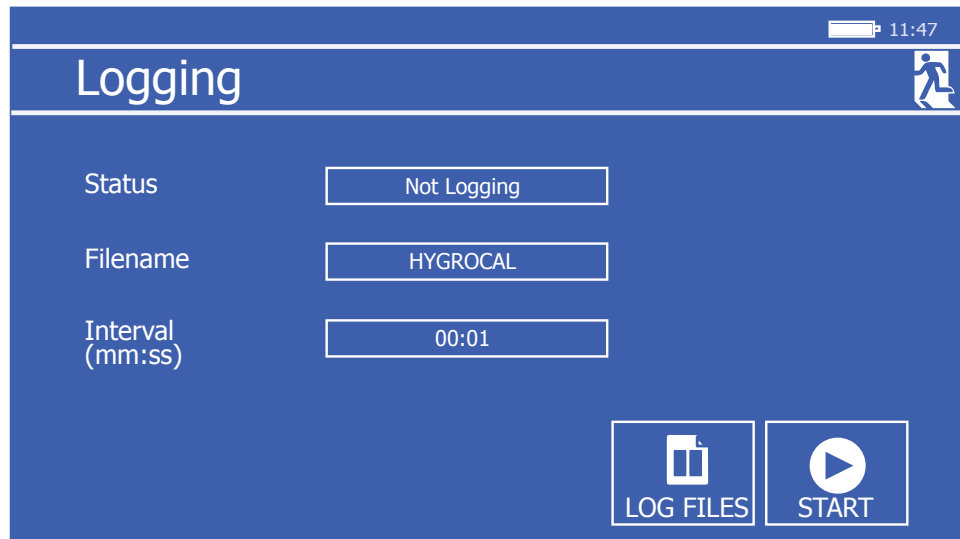
Figure 18 *HygroCal100 Logging Screen*

Parameter	Description
Status	Shows whether logging is active or not. Available Inputs: None
Filename	Sets the name for the next log file. Available Input: Text
Interval	Sets the frequency at which logged data will be collected. Available Inputs: Time in minutes and seconds

Table 3 *HygroCal100 Logging Screen Parameters*

Once a filename has been set, logging can be initiated by touching the **Start** button.

The Log Files Screen can also be accessed from here.

Log files

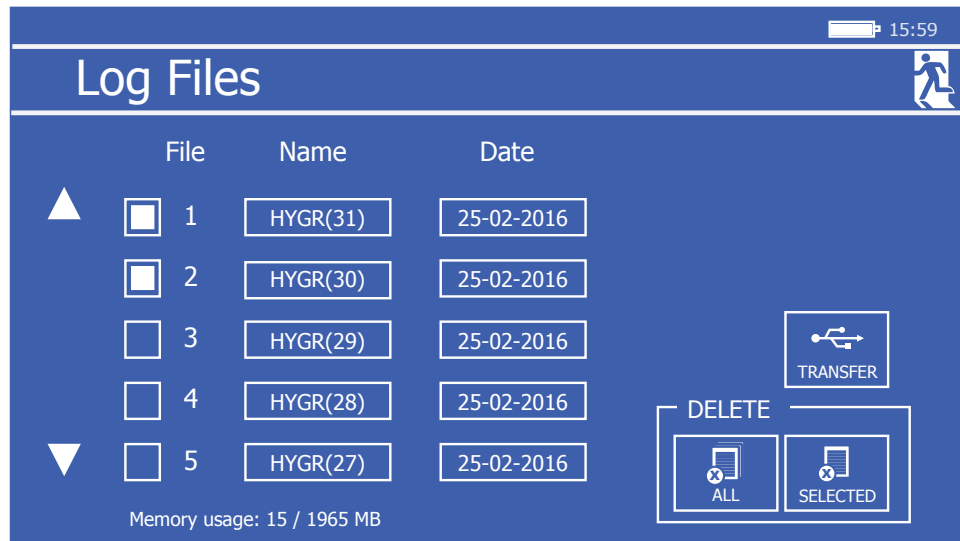
Figure 19 *Log Files Screen*

This screen allows management of the log files currently stored on the HygroCal100.

Each of the log files is listed as its own row in this screen, the rows are scrollable by means of the up and down arrows located on the left-hand side. The rows also have tick boxes, which can be used to highlight each independently.

Once a row has been highlighted, it can be either transferred to USB memory or deleted. Alternatively the **Delete: All** key can be used to wipe all logged data from the device.

3.4.4.5 Reference Setup

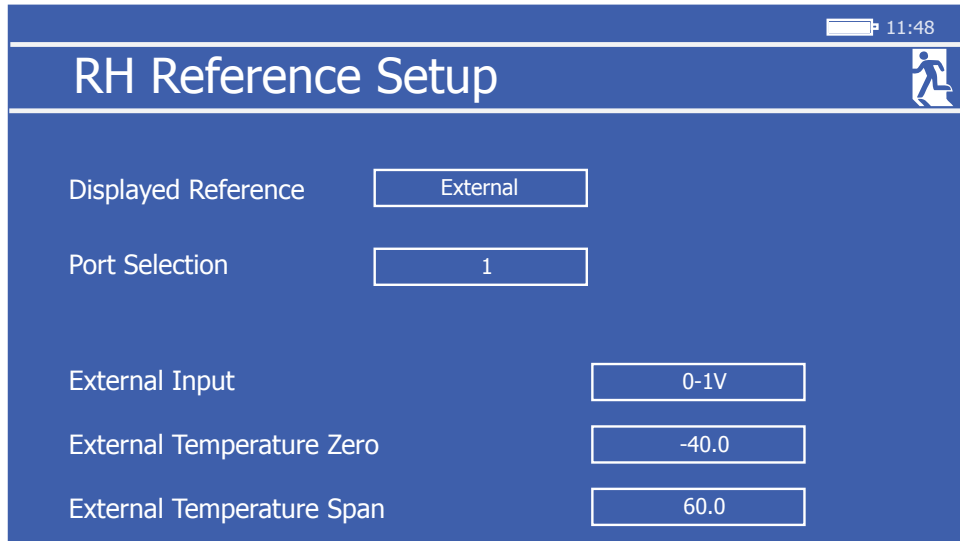

Figure 20 RH Reference Setup Screen

Parameter	Description
Displayed Reference	Chooses to display the readings of either the internal control sensor or an external device as the reference. Available Input: Internal, External
Port Selection	Selects the probe port if the external reference is connected.
External Input	Selects the output signal if the external reference is connected. Available Input: 0-1V, 0-5V, 0-10V, 0-20mA, 4-20mA
External Temperature Zero	Sets the temperature which corresponds to a zero output if the external reference is connected. Available Input: Numerical
External Temperature Span	Sets the temperature which corresponds to a span output if the external reference is connected. Available Input: Numerical

Table 4 RH Reference Setup Screen Parameters

3.4.5 System Settings

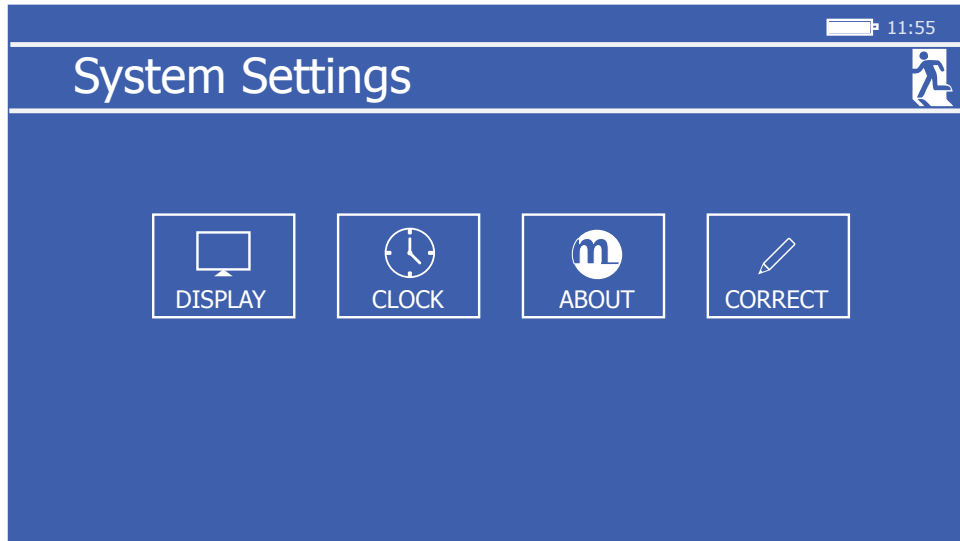

Figure 21 System Settings Screen

Used to configure the internal parameters of the HygroCal100, and to access the internal calibration correction functionality.

3.4.5.1 Display

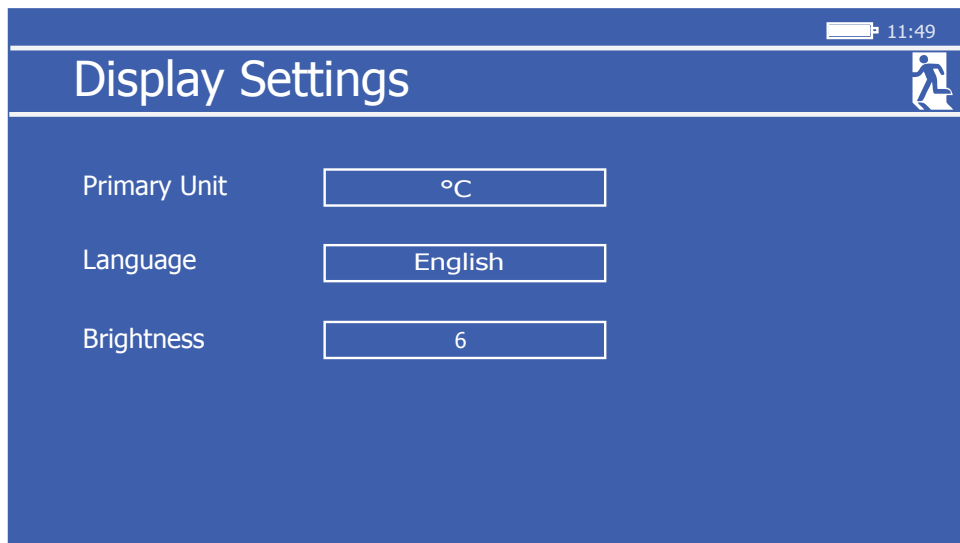

Figure 22 Display Settings Screen

Parameter	Description
Primary Unit	Changes the primary temperature unit. Available inputs: °C, °F
Language	Changes the display language. Available inputs: English, French, German, Spanish, Portuguese, Italian
Brightness	Alters display brightness. Available Inputs: 0-6

Table 5 Display Settings Screen Parameters

3.4.5.2 Clock

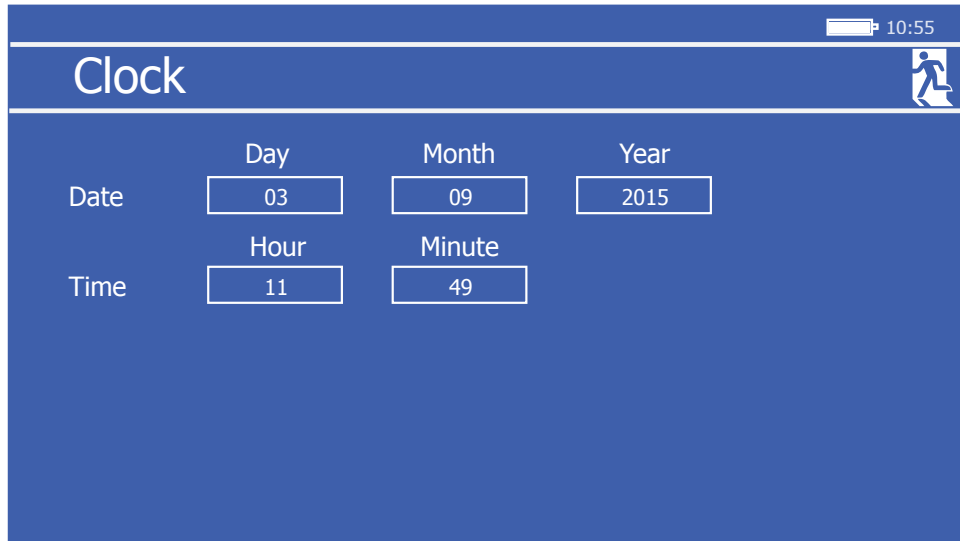

Figure 23 Clock Settings Screen

Parameter	Description
Day	Current Day. Available Inputs: DD
Month	Current Month. Available Inputs: MM
Year	Current Year. Available Inputs: YYYY
Hour	Current Hour. Available Inputs: HH
Minute	Current Minute. Available Inputs: MM

Table 6 Clock Settings Screen Parameters

3.4.5.3 About

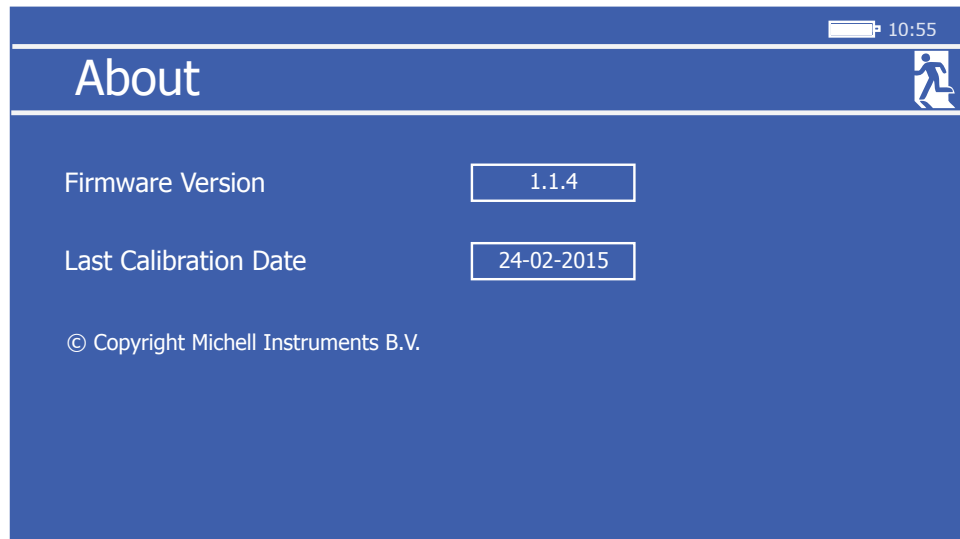

Figure 24 *About Screen*

Displays Firmware version, and date of last internal calibration correction.

3.4.5.4 Correct

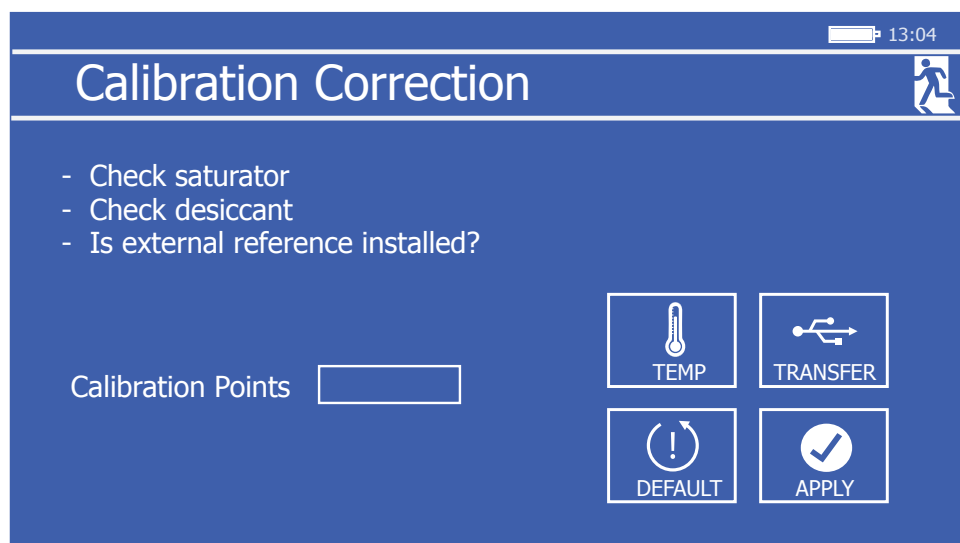

Figure 25 *Calibration Correction Screen*

In order to enter the Calibration Correction Screen, a prompt box will appear asking the user to enter a code. To proceed, enter **7316**.

The Calibration Correction Screen allows the initialization of an internal calibration routine. The number of calibration points can be changed between 3, 5 and 9.

The data collected from previous calibrations can be transferred to installed USB memory by means of the **Transfer** button.

The calibration correction can be reset to the default factory values, by means of the **Default** button.

Once started, the calibration procedure continues automatically, pausing once each point is complete to request confirmation to continue. As the calibration progresses, a table of the results collected will be displayed, along with the time remaining at the current point - see below.

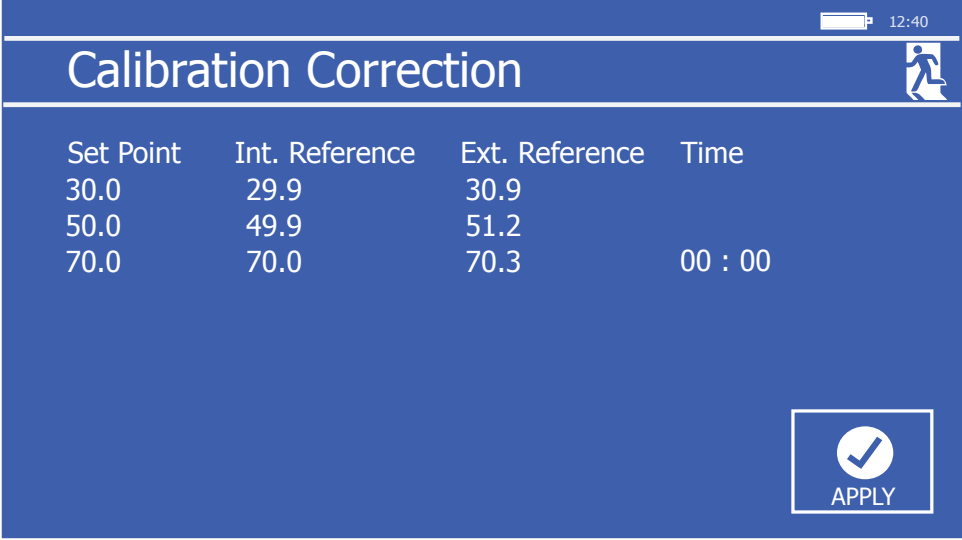

The screenshot shows a blue-themed interface titled "Calibration Correction". At the top right, there is a battery icon and the time "12:40". Below the title is a table with four columns: "Set Point", "Int. Reference", "Ext. Reference", and "Time". The table contains three rows of data. In the bottom right corner, there is a white button with a checkmark icon and the text "APPLY".

Set Point	Int. Reference	Ext. Reference	Time
30.0	29.9	30.9	
50.0	49.9	51.2	
70.0	70.0	70.3	00 : 00

Figure 26 *Calibration in Progress Screen*

Once all the requested calibration points have been completed, the **Apply** button will appear, to confirm and complete the correction process.

At any point the calibration can be cancelled by touching the **Exit** icon.

3.4.6 Table View

Table view allows the readings of the designated reference and all probes under test to be viewed simultaneously.

3.5 Port Adaptors

The HygroCal100 is fitted with 8 M30 probe test ports. Each of these is fitted with an adaptor to convert it to one of a variety of probe tube diameter sizes.



Figure 27 *Port Adaptor*

The HygroCal100 is supplied with your choice of port adaptor size - additional adaptors can be ordered.

Port adaptors suitable for the following probe sizes are available:

Probe Diameter	Order Code
12mm	A000291
13.5mm	A000292
14mm	A000293
15mm	A000294
18.5mm	A000295
19mm	A000296
24mm	A000297
25mm	A000298

Adaptors can be installed or removed using the Port Adaptor Tool (A000265). Take care to ensure that the port adaptor is properly aligned with the thread before tightening.



Figure 28 *Port Adaptor Tool*

3.6 Probe Installation

3.6.1 Chamber Connection

To install a probe into the HygroCal100 chamber, firstly ensure that you have the correct port adaptor size for the diameter of the probe.

1. Remove the blanking plug from the port adaptor and keep it safe.
2. Install the probe into the port adaptor - ensure that the probe is inserted as far as possible into the chamber as is possible while maintaining a good seal to the sensor body tube.

3.6.2 Electrical Connection

Seven push fit connector blocks are provided on the rear panel to allow power to and communications with the probes under test.

Each connector has 6 active pins, which can be used with 3 or 4-wire probes which have either a voltage or current output, depending on how it is wired.

Pin	Function	Description
1	+24 V DC supply	Excitation voltage for probe
2	Ground	Ground
3	RH voltage input	RH input connection for probes with a voltage scale output
4	Temperature voltage input	Temperature input connection for probes with a voltage scale output
5	RH current input	RH input connection for probes with a current scale output
6	Temperature current input	Temperature input connection for probes with a current scale output
7	N/C	Not connected
8	N/C	Not connected

NOTE: This table also appears on the rear panel of the instrument for quick reference.

For each connection:

1. Remove the terminal block.
2. Strip back the wires on the probe lead to ensure at least 6mm is exposed (if necessary).
3. Insert the wire for the ground connection into the Ground terminal way, and screw into the block. **NOTE: Do not overtighten the screw.**
4. Insert the wire for the supply connection into the +24 V DC terminal way, and screw into the block. **NOTE: Do not overtighten the screw.**
5. Insert the wire for the RH signal connection into either the RH voltage input or RH current input terminal way - depending on the probe - and screw into the block. **NOTE: Do not overtighten the screw.**
6. Insert the wire for the temperature signal connection (if present) into either the Temperature Voltage Input or Temperature Current Input terminal way - depending on the probe - and screw into the block. **NOTE: Do not overtighten the screw.**
7. Locate the terminal block over the connector and push it firmly into place.

3.7 Battery Operation

The HygroCal100 is fitted with a battery pack, allowing it to be used without the DC power supply connected.

The HygroCal100 can run from a fully charged battery for approximately 8 hours (depending on set point).

The battery pack will power the instrument automatically when the DC supply is disconnected.

3.8 Operating Guide

3.8.1 Manual Mode

When the Operating Mode is set to Manual, the chamber will continually generate the currently selected set point. The set point is determined by touching the 'set point' indication on the Main Screen, which brings up a window allowing the desired value to be entered.



Figure 29 *Set Point Entry Screen*

3.8.2 Automatic Mode

In order to program a calibration routine to run automatically, the operating mode should first be set to **Auto** from the Calibration Settings Screen -> **Mode**.

A calibration routine can then be defined, through the Calibration Settings Screen -> **Program**. Each point in the calibration is listed by row. Touching the up or down arrows on the left of the list will scroll through the 10 points which can be assigned.

Each row contains a relative humidity value in %, and a duration in the format HH:MM. For each row, the target relative humidity value will be maintained for the duration. **NOTE: The duration does not include time taken to reach and stabilize on the target.** Consider the example calibration routine in *Figure 30*, and its visualization in the chart in *Figure 31*.

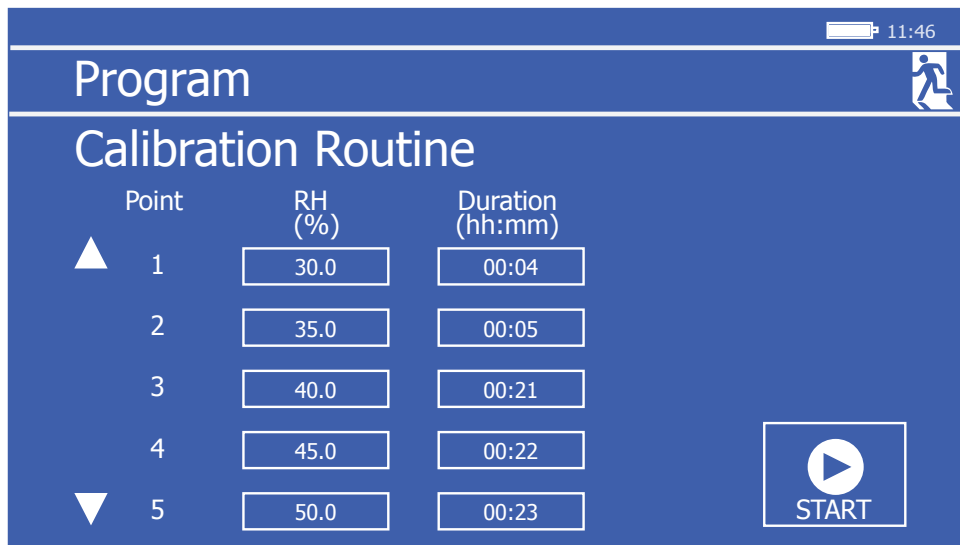

Figure 30 Example of Calibration Routine

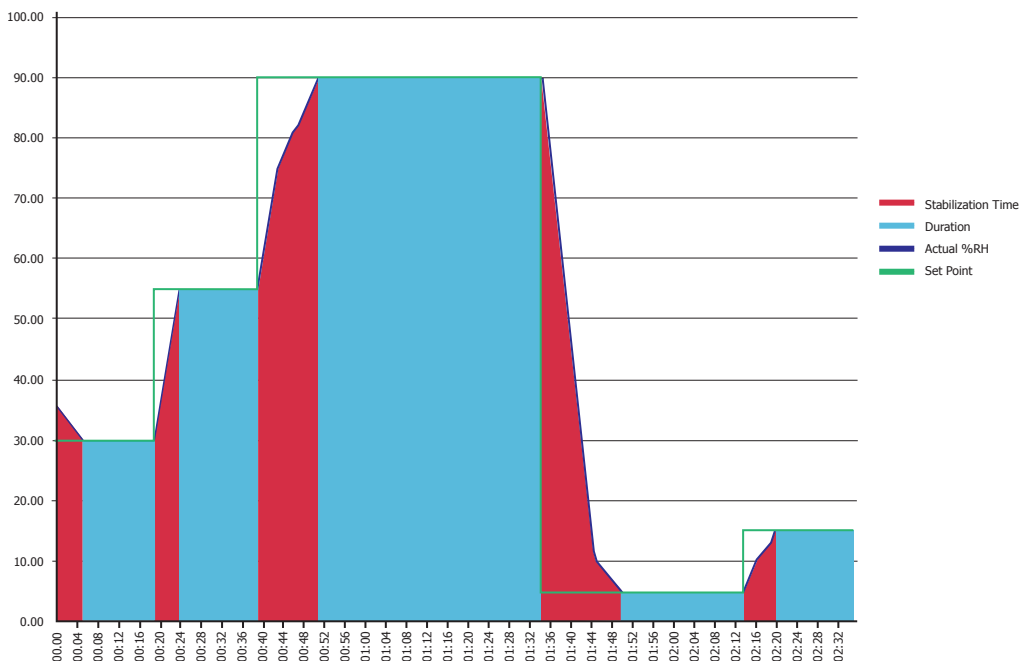

Figure 31 Visualization of Calibration Routine

The time taken for the chamber to respond to the set point is shown in red fill - this is not included in the duration for that set point, which is shown in blue fill.

When the step change in humidity is large, the chamber will take longer to reach the set point. It will typically take much longer to dehumidify than to humidify, so the transition from 30% to 50% will be quicker than 50% to 30%.

3.9 Operating Practice

To perform a reliable humidity validation, it is important to follow these basic guidelines:

When starting a validation routine, ensure that the temperature of the environment you intend to operate in is stable, and that the HygroCal100 has been in the stable environment for enough time to reach temperature equilibrium with its surroundings.

If the HygroCal100 is not allowed time to stabilize with its environment, then the conditions that each probe under test experiences may not be the same. Due to the key influence temperature has on determining relative humidity, validation errors would result.

For example, at an ambient of 23°C and a set point of 40%RH, a difference of 0.5°C could affect the RH by up to 1.25%. At lower humidities the difference can be even more significant.

When running a validation routine, it is usually advisable to start with the driest points first and increase the humidity.

There are several benefits to this:

- Speed of transition - it is much quicker for the chamber to add humidity than to remove it, therefore a validation running from dry to wet will require shorter transition and stabilization times than one running from wet to dry.
- Service life of desiccant - repeatedly asking the chamber to dehumidify will result in a much shorter desiccant lifetime than if the cycle is run so that humidity only needs to be added.

Always ensure, when installing probes into the chamber, that the port adaptor used is of the correct diameter for the probe body, so that there are no potential leak points.

3.9.1 Humidity Stabilization Times

The time taken for the HygroCal chamber to stabilize after a transition will depend on a number of factors:

- Magnitude of the humidity change
- Direction of the humidity change
- Temperature of the operating environment

To take an extreme example, expect that for complete stability at 95% RH from a starting point of 5%, 35 minutes should be allowed.

For smaller transitions, shorter timescales can be expected. Typically for a step change $<\Delta 50\%$, stability can be reached within 15 minutes.

3.9.2 Data Logging

The logging function, when active, will continually capture the the target set point in addition to the readings of the internal reference and all probes under test. This will be written to the internal memory as a CSV file.

The files are identified both by number and by the name assigned as the log is initiated. The Log Files Screen allows multiple files to be selected and downloaded.

3.10 Standby Mode

Standby mode can be activated through the Calibration Settings Screen -> **Mode** (see Section 3.4.4.1). When it is active the pump will shut off and the unit will not control the chamber condition.

3.11 External Reference Configuration

It is possible to define one of the devices connected into the chamber as an external reference. The readings of this device will be displayed as the reference readings on the Main Screen. However, the internal reference will still be used to control the chamber.

When choosing an external reference, the port to which it is connected must be selected. The range and input settings which were previously set for this port will be loaded, but fields to change them can be found on the Calibration Settings Screen -> **Ref Setup** (see Section 3.4.4.5).

An external reference must be connected in order to carry out a calibration correction of the internal reference.

4 MAINTENANCE

4.1 Desiccant Reservoir

The desiccant reservoir should be filled up to the inside lip - this will require approximately 25cm³ of desiccant.

When fresh, the desiccant will be orange, as shown below:

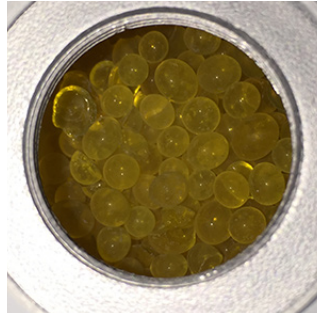

As it becomes exhausted, it will lose its color and become clear.



To replace the desiccant, it is preferable to empty the chamber by use of a vacuum cleaner.

The desiccant can be regenerated by emptying it completely from the desiccant chamber and drying it in an oven for approximately 3 hours at a temperature between 130°C (266°F) and 160°C (320°F). After drying it in an oven, allow the silica gel to cool before refilling the desiccant chamber.

Alternatively spare desiccant can be ordered in two different package sizes:

Quantity	Order Code
250g	A000171
3kg	A000172

4.2 Saturator Reservoir

The saturator should be filled with 25ml of distilled water. The water level in the saturator will reduce over time as it is consumed in the process of humidifying the chamber.

NOTE: Always remove water from the saturator reservoir before transportation.

4.3 Replacing the Internal Reference Sensor

The internal reference is a Michell Instruments HygroSmart 3 control sensor.

A replacement can be ordered from your local Michell Instruments representative, using the part number: HS3-S-B1.

To replace the sensor:

1. Loosen the two screws securing the service panel to the rear of the unit.
2. The reference sensor is attached to the service panel, and sealed into the control chamber by an O-ring. Gently pull the panel away, removing the HS3 control sensor from the chamber.
3. Unscrew the collar at the base of the HS3, then pull the HS3 away from the connector which attaches it to the service panel.
4. The replacement control sensor can then be installed in its place.

4.4 Calibration Correction

The HygroCal100 is provided with an intuitive calibration correction system which is used to calibrate and adjust the internal HS3 control sensor against an external reference device.

If a traceable reference is available, it is advisable to pass the traceability of this onto the control sensor of the HygroCal100 at regular intervals. The process allows calibration at 3, 5 or 9 preset points, which are:

Preset	RH Points	Total time to complete
3 point	30%, 50%, 70%	45mins
5 point	20%, 30%, 50%, 70%, 80%	1hr 15mins
9 point	10%, 20%, 30%, 40%, 50%, 60%, 70%, 80%, 90%	2hr 15mins

Select System Settings -> **Correct**. This will display a prompt to enter a password to proceed - the required code is **7316**. Once this has been entered, the Calibration Correction Setup Screen will be displayed. This screen shows a number of checks which should be carried out before proceeding.

NOTE: If the desiccant is exhausted, or the saturator is not sufficiently filled, then this can result in an invalid correction being applied to the control sensor.

NOTE: Ensure that the temperature of the environment you intend to operate in is stable before proceeding.

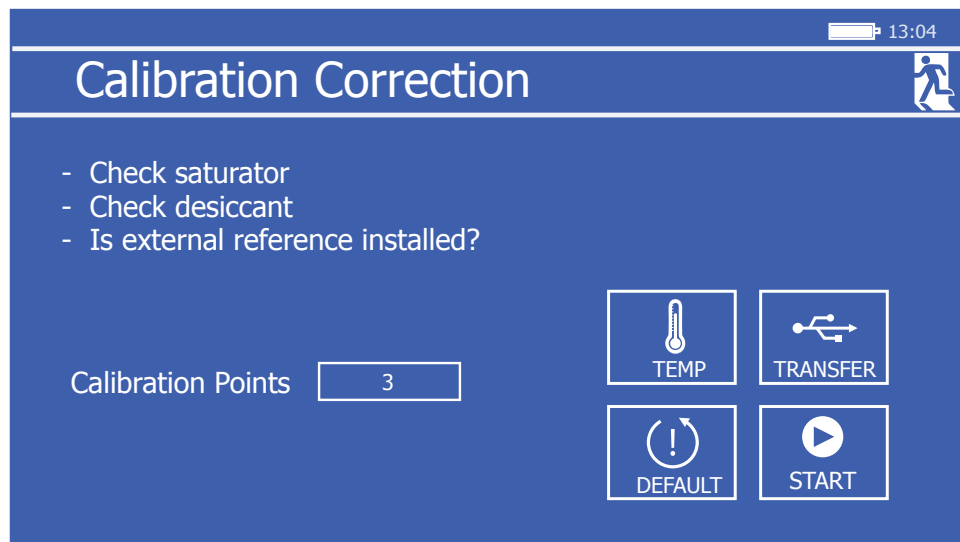

Figure 32 Calibration Correction Setup Screen

The Calibration Correction Setup Screen allows selection of the desired number of calibration points. Once this choice is made, touch the **Start** button to begin the calibration.

Previous calibration corrections can be downloaded to USB memory by touching the **Transfer** icon, and will be stored in CSV format as per the log data files (see Section 3.9.2 for further information).

Install and configure an authoritative external reference instrument before proceeding. If this is not done, then the External Reference Setup Screen will be displayed. Proceeding from here will begin the calibration correction routine.

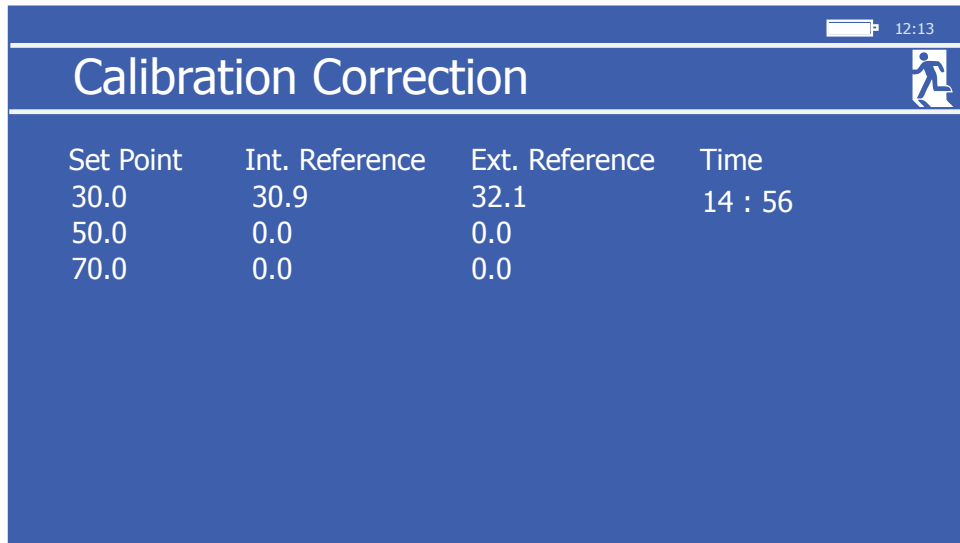

Figure 33 Calibration Correction Screen

The Calibration Correction Screen will then be displayed, and the chamber set point will be changed to the first point in the routine. After 15 minutes, the values read by both the sensor and reference will be sampled to determine the required correction. An icon labelled **next** will appear in the bottom right of the screen - touch this to confirm and continue to the next point.

After all points are complete, the **Apply** button will appear. Pressing this will apply the table and complete the calibration.

At any point during the process, touching the **Exit** icon will abandon the current calibration.

Appendix A

Technical Specifications

Appendix A Technical Specifications

Chamber	
Generation Range	5 to 95% RH
RH Stability	±0.5%
RH Uniformity	±0.5%
Stabilization Time	Typically <5 min for full stability from step changes of 10% RH
Control Probe	
Accuracy	±0.8%
Long Term Stability	±1% per year
Electrical Specification	
User Interface	4.3" color LCD with touchscreen
Measurement Units	%RH, temperature in °C, °F
Displayed Resolution	0.1
Data Logging	2Gb internal memory available for log files; or 10.6 years storage at 5 second intervals
Battery	1500 mAh
Power Supply	24 V DC (100 to 240 V AC, 50/60 Hz adaptor included)
Mechanical Specification	
Probe Ports	8 - sensor body diameters 5 to 25mm, accommodated by port adaptors
Chamber Volume	1050cm ³ approximately
Maximum Probe Insertion Depth	60mm (2.36")
Desiccant Reservoir Capacity	25cm ³
Saturator Reservoir Capacity	25ml
Environmental Conditions	+5 to +40°C (+41 to +104°F)
Dimensions	100 x 250 x 300mm (3.94 x 9.84 x 11.81") h x w x d
Weight	3.2kg (7.05lbs)

Appendix B

Troubleshooting

Appendix B Troubleshooting

Problem	Possible Solution
Not drying or drying slowly	Change desiccant
Water in chamber	Dry chamber
Not humidifying or humidifying slowly	Water level too low

Appendix C

EU Declaration of Conformity

Appendix C EU Declaration of Conformity

EU Declaration of Conformity

Manufacturer: **Michell Instruments BV**
Krombraak 11
4906 CR Oosterhout
The Netherlands



We declare under our sole responsibility that the product:

HygroCal100

complies with all the essential requirements of the EU directives listed below.

2004/108/EC EMC Directive

and has been designed to be in conformance with the relevant sections of the following standards or other normative documents.

EN61326-1:2013 Electrical equipment for measurement, control and laboratory use – EMC requirements –Class B (emissions) and Industrial Locations (immunity).

A handwritten signature in black ink, appearing to be 'Peter Haakma', written over a horizontal line.

Peter Haakma, Managing Director

Date of Issue: June/2015

Appendix D

Quality, Recycling & Warranty Information

Appendix D Quality, Recycling & Warranty Information

D.1 Pressure Equipment Directive (PED) 97/23/EC

The above Directive has been implemented in United Kingdom Law by the Pressure Equipment Regulations 1999.

The Regulations require that all pressure equipment and assemblies within the scope of the Pressure Equipment Directive must be safe when placed on the market or put into service.

Michell Instruments' products have been assessed and, as referenced against the Classification Charts detailed in Annex II of the Directive, do not fall into the requirements for CE marking compliance with the Pressure Equipment Directive.

Article 3, paragraph 3 states that any product containing a pressurized fluid that does not qualify for compliance should, nevertheless, be constructed with Sound Engineering Practice (SEP).

Michell Instruments attests here that its products have been designed, manufactured & tested to assure safe operation, and in accordance with Sound Engineering Practices.

D.2 Recycling Policy



Michell Instruments is concerned with the protection of the environment. It is our commitment to reduce and eliminate from our operations, wherever possible, the use of substances which may be harmful to the environment. Similarly, we are increasingly using recyclable and/or recycled material in our business and products wherever it is practical to do so.

To protect natural resources and to promote material reuse, please separate batteries from other types of waste and recycle responsibly. If batteries are not properly disposed of, these substances can cause harm to human health and the environment.

The product that you have purchased may contain recyclable and/or recycled parts and we will be happy to provide you with information on these components if required. For further information please see the following sections.

D.3 WEEE Compliance

Directive 2012/19/EU 4 July 2012 on Waste Electronic and Electrical Equipment (WEEE)

The Waste Electronic and Electrical Equipment (WEEE) Directive places rules upon European manufacturers of electrical and electronic equipment. The directives' aim is to reduce the impact that electronic devices have on the environment.

Michell Instruments is in full compliance with the WEEE Directive and is registered with an approved recycler (Registration No. WEE/JB0235YW) and treats the requirement of the directive and the protection of the environment with the utmost importance. All Michell Instruments' products are appropriately marked indicating their requirement for recycling.

It may be required to return certain instruments for treatment at the end of their working life.

Feb 2013

D.4 RoHS2 Compliance

Directive 2011/65/EU of the European Parliament and of the Council of 8 June 2011

The Restriction of Hazardous Substances (RoHS) Directive places rules upon European manufacturers of electrical and electronic equipment. The directives' aim is to reduce the impact that electronic devices have on the environment.

According to the EC Directive 2002/95/EC, Michell Instruments' products qualify as Category 9, Control and Monitoring Equipment. Under the 2002/95/EC Directive, Category 9 products are exempt from compliance with the Directive.

However, the careful design of all Michell Instruments' products takes into consideration the requirements of the Directive and, wherever possible, compliance is achieved. All future products will be developed entirely using compliant materials. Furthermore, Michell Instruments is taking active steps to remove non-compliant materials and components from existing products wherever these may occur. Presently, none of the non-compliant materials are known to occur in Michell Instruments' products.

The new Directive 2011/65/EU (RoHS2) entered into force on 21 July 2011 and required all Member States to transpose the provisions into their respective national laws by 2 January 2013.

Under the provisions of the RoHS2 EU Directive 2011/65/EU (Article 3, [24]) defines 'Control and Monitoring Equipment' specifically as 'monitoring and control instruments designed exclusively for industrial or professional use'.

RoHS2 EU Directive 2011/65/EU states the closing date for compliance of any Control and Monitoring Equipment product sold into the EU market place as 22nd July 2017.

However, the careful design policy of all Michell Instruments' products continues to attain compliance in the shortest practical timescales and strives to ensure that less than 0.1% of total mass per product, of all non-compliant materials, appear within them. Michell Instruments continues to monitor suppliers and material sources to ensure that compliance of goods provided is maintained.

January 2013

D.5 Warranty

Unless otherwise agreed, the Supplier warrants that, as from the date of delivery for a period of 12 months, the goods and all their component parts, where applicable, are free from any defects in design, workmanship, construction or materials.

The Supplier warrants that the services undertaken shall be performed using reasonable skill and care, and be of a quality conforming to generally accepted industry standards and practices.

Except as expressly stated, all warranties whether express or implied, by operation of law or otherwise, are hereby excluded in relation to the goods and services to be provided by the Supplier.

All warranty services are provided on a return to base basis. Any transportation costs for the return of a warranty claim shall reside with the Customer.

D.6 REACH Compliance

Regulation (EC) No. 1907/2006

Registration, Evaluation, Authorisation and Restriction of Chemicals (REACH)

Michell Instruments is a manufacturer of moisture measurement and gas analysis instrumentation and is a 'downstream' user of chemicals, as described by the EU Council Directive 76/769/EEC. The products we supply are not raw chemical products (goods).

Under normal and reasonably foreseeable circumstances of application, the goods supplied to you shall not contain or release any prohibited chemicals. No listed SVHC (Substances of Very High Concern) appear within products manufactured by Michell Instruments. Therefore the 0.1% mass per product, or total usage of 1 tonne/year, will never be exceeded. For these reasons we are neither required by obligation for registration nor for the creation of material safety data sheets (MSDS) for our products.

Our continued review of the SVHC Candidate List and latest additions is to ensure we remain compliant.

Michell Instruments maintains a hazardous material register in which MSDS data sheets are collated, and we will check that our suppliers will comply to REACH requirements for all materials and substances we use in the processes of our manufacturing.

In the unlikely event that any chemicals of concern appear in our products in quantities greater than 0.1% of total mass per product we will immediately inform you by correspondence according to the REACH Article 33 requirements. Our current appraisal is, however, that we do not expect or foresee such an incidence.

January 2013

D.7 Return Policy

If a Michell Instruments' product malfunctions within the warranty period, the following procedure must be completed:

1. Notify a Michell Instruments' distributor, giving full details of the problem, the model variant and the serial number of the product.
2. If the nature of the problem indicates the need for factory service then the instrument should be returned to Michell Instruments, carriage prepaid, preferably in the original packaging, with a full description of the fault and the customer contact information.
3. Upon receipt, Michell Instruments will evaluate the product to determine the cause of the malfunction. Then, one of the following courses of action will be taken:
 - If the fault is covered under the terms of the warranty, the instrument will be repaired at no cost to the owner and returned.
 - If Michell Instruments determines that the fault is not covered under the terms of the warranty, or if the warranty has expired, an estimate for the cost of the repairs, at standard rates, will be provided. Upon receipt of the owner's approval to proceed, the product will be repaired and returned.

D.8 Calibration Facilities

Michell Instruments' calibration facilities are among the most sophisticated in the world and have been recognized for their excellence.

Traceability to the National Physical Laboratory (NPL) UK is achieved through our UKAS Accreditation (Number 0179). This covers dew point over the range -90 to +90°C (-130 to +194°F) and also Relative Humidity.

Dew-point calibrations are also traceable to the National Institute for Standards & Technology (NIST) USA over the range -75 to +20°C (-103 to +68°F).

NOTE: Standard traceable calibration certificates for instruments and sensors are not issued under our UKAS accreditation.

D.9 Manufacturing Quality

Michell Instruments is registered with the British Standards Institute for Quality Assurance to:

BS EN ISO 9001: 2008

Rigorous procedures are performed at every stage of production to ensure that the materials of construction, manufacturing, calibration and final test procedures meet the requirements laid down by our BSI approved Quality System.

Please contact Michell Instruments (www.michell.com) if the product does not arrive in perfect working order.

D.10 FCC (EMC Requirements for North America)

This device complies with part 15 of the FCC Rules. Operation is subject to the following two conditions:

1. This device may not cause harmful interference.
2. This device must accept any interference, including interference that may cause undesired operation.

This equipment has been tested and found to comply with the limits for a Class A digital device, pursuant to part 15 of the FCC Rules. These limits are designed to provide reasonable protection against harmful interference when the equipment is operated in a commercial environment. This equipment generates, uses, and can radiate radio frequency energy and, if not installed and used in accordance with the user manual, may cause harmful interference to radio communications. Operation of this equipment in a residential area is likely to cause harmful interference in which case the user will be required to correct the interference at his own expense. This product must be operated as per the operating instructions provided. Do not make any alterations or modifications to the product. Any unauthorized alterations or modifications made to this product may require you to stop operating the product.

Canadian Radio Interference Regulations.

This Class A digital product complies with Canadian ICES-001. Règlement canadien sur les interférences radio. Ce produit numérique de classe A est conforme à la norme NMB-001.

Appendix E

Return Document & Decontamination Declaration

Appendix E Return Document & Decontamination Declaration

Decontamination Certificate

IMPORTANT NOTE: Please complete this form prior to this instrument, or any components, leaving your site and being returned to us, or, where applicable, prior to any work being carried out by a Michell engineer at your site.

Instrument			Serial Number	
Warranty Repair?	YES	NO	Original PO #	
Company Name			Contact Name	
Address				
Telephone #			E-mail address	
Reason for Return /Description of Fault:				
Has this equipment been exposed (internally or externally) to any of the following? Please circle (YES/NO) as applicable and provide details below				
Biohazards			YES	NO
Biological agents			YES	NO
Hazardous chemicals			YES	NO
Radioactive substances			YES	NO
Other hazards			YES	NO
Please provide details of any hazardous materials used with this equipment as indicated above (use continuation sheet if necessary)				
Your method of cleaning/decontamination				
Has the equipment been cleaned and decontaminated?			YES	NOT NECESSARY
Michell Instruments will not accept instruments that have been exposed to toxins, radio-activity or bio-hazardous materials. For most applications involving solvents, acidic, basic, flammable or toxic gases a simple purge with dry gas (dew point <-30°C) over 24 hours should be sufficient to decontaminate the unit prior to return. Work will not be carried out on any unit that does not have a completed decontamination declaration.				
Decontamination Declaration				
I declare that the information above is true and complete to the best of my knowledge, and it is safe for Michell personnel to service or repair the returned instrument.				
Name (Print)			Position	
Signature			Date	





<http://www.michell.com>