



Easidew PRO XP Moisture Transmitter User's Manual



97442 Issue 6
May 2019

Please fill out the form(s) below for each instrument that has been purchased.

Use this information when contacting Michell Instruments for service purposes.

Instrument	
Code	
Serial Number	
Invoice Date	
Location of Instrument	
Tag No	

Instrument	
Code	
Serial Number	
Invoice Date	
Location of Instrument	
Tag No	

Instrument	
Code	
Serial Number	
Invoice Date	
Location of Instrument	
Tag No	



Easidew PRO XP

For Michell Instruments' contact information please go to
www.michell.com

© 2019 Michell Instruments

This document is the property of Michell Instruments Ltd. and may not be copied or otherwise reproduced, communicated in any way to third parties, nor stored in any Data Processing System without the express written authorization of Michell Instruments Ltd.

Contents

Safety	vii
Toxic Materials	vii
Repair and Maintenance	vii
Calibration	vii
Safety Conformity	vii
Abbreviations.....	viii
1 INTRODUCTION	1
1.1 Features	1
2 INSTALLATION	2
2.1 Unpacking the Instrument.....	2
2.1.1 Wall Mounting	3
2.1.2 Pipe Mounting.....	5
2.2 Gas Media Process Connection	6
2.3 Liquid Media Process Connection	7
2.3.1 Sample Block (Optional)	8
2.3.2 Orientating the display	9
2.4 Hazardous Area Safety.....	10
2.5 Electrical Safety	12
2.5.1 Equipment Ratings and Installation Details.....	12
2.6 Pressure Safety	14
2.7 Electrical Schematic.....	14
2.7.1 Easidew PRO XP EX1 (Non-Display).....	14
2.7.2 Easidew PRO XP EX2 (Display).....	15
2.7.3 Electrical Boundaries	15
2.8 Preparation of the Sensor Cable	16
2.8.1 Terminal Block Connection - Easidew PRO XP EX1 (Non-Display)	16
2.8.2 Terminal Block Connection - Easidew PRO XP EX2 (Display)	17
3 OPERATION	19
3.1 Measurement and Configuration	19
3.2 Sampling Hints.....	20
4 MAINTENANCE	21
4.1 Calibration	21
4.2 Sensor Guard Replacement	21
4.3 Display Replacement.....	22
4.4 O-Ring Replacement.....	23

Figures

Figure 1	Sensor Cap Removal.....	2
Figure 2	Dimensions Easidew PRO XP EX1 (Non-Display) - Wall Mounting.....	3
Figure 3	Dimensions Easidew PRO XP EX2 (Display) - Wall Mounting.....	4
Figure 4	Transmitter Mounting - Pipe or Duct.....	5
Figure 5	Dimensions Easidew PRO XP EX1 (Non-Display) - Pipe or Duct	5
Figure 6	Dimensions Easidew PRO XP EX2 (Display) - Pipe or Duct	5
Figure 7	Transmitter Direct Mounting	6
Figure 8	Transmitter Mounting - Sample Block.....	8
Figure 9	Outline Dimensions - Sample Block.....	8
Figure 10	Orientating the display.....	9
Figure 11	Electrical Schematic - Easidew PRO XP EX1 (Non-Display)	14
Figure 12	Electrical Schematic - Easidew PRO XP EX2 (Display)	15
Figure 13	Maximum Load of Easidew PRO XP - Including Cable Resistance.....	15
Figure 14	Wire and Crimp Details	16
Figure 15	Terminal Block Connection - Easidew PRO XP EX1 (Non-Display)	16
Figure 16	Grub Screw	17
Figure 17	Terminal Block Mounting - Easidew PRO XP EX2 (Display)	17
Figure 18	Grub Screw	18
Figure 19	Indication of Dead Space	20
Figure 20	Replacement of Sensor Guard	21

Appendices

Appendix A	Technical Specifications.....	25
Appendix B	Hazardous Area Certification	27
	B.1 Product Standards	27
	B.2 Product Certification	27
	B.3 Global Certificates/Approvals	28
	B.4 Special Conditions.....	28
	B.5 Maintenance and Installation.....	28
Appendix C	Fully Programmable Loop Powered 4-Digit LED Display Meter	30
	C.1 Display Meter Parameter Limits.....	30
	C.2 Display Meter Operating Range.....	30
	C.3 Display Meter View	30
	C.4 Re-Configuration Steps.....	31
	C.5 Moisture Scaling Label	32
	C.6 Technical Specifications - EX2 LED Display.....	33
Appendix D	Quality, Recycling & Warranty Information.....	35
Appendix E	Return Document & Decontamination Declaration.....	37

Safety

The manufacturer has designed this equipment to be safe when operated using the procedures detailed in this manual. The user must not use this equipment for any other purpose than that stated. Do not apply values greater than the maximum value stated.

This manual contains operating and safety instructions, which must be followed to ensure the safe operation and to maintain the equipment in a safe condition. The safety instructions are either warnings or cautions issued to protect the user and the equipment from injury or damage. Use qualified personnel and good engineering practice for all procedures in this manual.



Where this symbol appears in the following sections it is used to indicate areas where potentially hazardous operations need to be carried out and where particular attention to personal and personnel safety must be observed.

Toxic Materials

The use of hazardous materials in the construction of this instrument has been minimized. During normal operation it is not possible for the user to come into contact with any hazardous substance which might be employed in the construction of the instrument. Care should, however, be exercised during maintenance and the disposal of certain parts.

Long exposure to, or breathing of the calibration gases, may be dangerous.

Repair and Maintenance

The instrument must be maintained either by the manufacturer or an accredited service agent. For Michell Instruments' worldwide offices contact information go to www.michell.com.

Calibration

Prior to shipment, the analyzer undergoes stringent factory calibration to traceable standards. Due to the inherent stability of the instrument, regular field calibration should not be required under controlled operating conditions. However, Michell Instruments recommends that a calibration be considered at intervals of every 12 months of the instrument's life.

Michell Instruments can provide a fully traceable factory calibration service. Please contact your local Michell Instruments' office or representative for further details (www.michell.com).

Otherwise the analyzer should perform reliably for many years with just basic maintenance and housekeeping.

Safety Conformity

This product carries the CE mark and meets the requirements of relevant European safety directives.

Abbreviations

The following abbreviations are used in this manual:

A	ampere
A/F	across flats
barg	pressure unit (=100 kP or 0.987 atm) gauge
°C	degrees Celsius
°F	degrees Fahrenheit
dp	dew point
DC	direct current
EU	European Union
fps	feet per second
HDPE	high-density polyethylene
ins	inches
I/O	Input/Output
ISO	International Organization for Standardization
K	Kelvin unit of temperature measurement
lb/MMSCF	pounds of water per million standard cubic feet of gas
lbf-ft	pound foot
NI/min	normal liters per minute
m	meters
mA	milliampere
mg/m ³	milligrams per cubic meter
mm	millimeter
mm ²	millimeter squared
Mpa	megapascal
m/sec	meters per second
Nm	Newton meter
pcb	printed circuit board
psig	pounds per square inch (gauge)
ppm _v	parts per million by volume
ppm _w	parts per million by weight
PTFE	Polytetrafluoroethylene
Ra	roughness average (unit of measure of surface finish)
RH	relative humidity
scfh	standard cubic feet per hour
UNF	unified fine thread
µm	micrometer
"	inches
%	percentage
V	Volts

1 INTRODUCTION

The Easidew PRO XP has been manufactured, tested and calibrated to the highest available standards and should arrive in perfect working order, ready for installation into a gas or liquid measurement application.

For questions about the instrument or how to install and operate it, contact your local representative. Refer to www.michell.com for details of Michell Instruments' worldwide offices' contact information.

There are two variants of the Easidew PRO XP, each available with various options for display, housing, range, etc.:

Easidew PRO XP-TX	For gases
Easidew PRO XP-LQ-TX	For liquids

1.1 Features

The Easidew PRO XP is a continuous, on-line, 4-20 mA transmitter for the measurement of moisture content in air, other non-corrosive gases and non-polar liquids. It is designed specifically for use within Zone 1 & 2 and Zone 21 & 22 Hazardous Areas (ATEX & IECEx) and Class I, Division 1, Groups A, B, C & D, Class II and III, Division 1, Groups E, F & G, Class I, Zone 1 & Zone 21 Hazardous Locations (N. America). See appendix A and B for further details.

The Easidew PRO XP key features are:

- Measurement ranges -110 up to +20°Cdp (-166 to +68°Fdp)
- Global explosion / flameproof certification
- Accuracy $\pm 1^{\circ}\text{Cdp}$ ($\pm 1.8^{\circ}\text{Fdp}$)
- 2-wire 4-20 mA output
- Traceable 13-point calibration certificate
- 450 bar (6526 psi) pressure rating
- 3/4" UNF industry standard process connection
- EN 10204 3.1 material certification
- Moisture in gases and liquids
- Optional integral display meter
- Aluminium or stainless steel enclosure

2 INSTALLATION

2.1 Unpacking the Instrument

On delivery, please check that all the following standard components are present in the packing box:

- Easidew PRO XP Transmitter (EX1 - Non-display OR EX2 - Display)
- Certificate of calibration
- 2 off bootlace ferrules
- 1.5mm A/F allen key (aluminium housing version only)
- 2mm A/F allen key (stainless steel housing version only)
- 1 off conduit entry blanking plug (fitted hand tight)
- Installation and maintenance information sheet
- Sample block (optional)
- Pipe mounting bracket (optional)
- EN10204 3.1 material certificates (optional)

The Easidew PRO XP is protected within the main packaging with a green cap protecting the sensor guard with a desiccant capsule inside, and a plastic cap inside the cable entry opening (see *Figure 1*).

Remove and retain these items prior to commissioning.



DO NOT HANDLE THE SENSOR GUARD

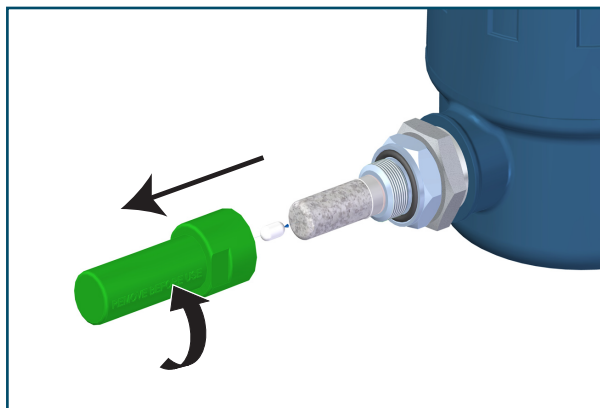

Figure 1 *Sensor Cap Removal*

2.1.1 Wall Mounting

The instrument is housed in an aluminum or stainless steel Exd enclosure suitable for wall or panel mounting. Two mounting points are available with $\varnothing 7\text{mm}$ ($\varnothing 0.3''$) clearance holes on fixing centers 127mm (5'') apart. Use 2 off max 6.5mm (0.25'') diameter mounting fasteners with a minimum length of 35mm (1.4'').

The enclosure provides environmental ingress protection IP66/NEMA4 and should be mounted vertically in a location free of any appreciable vibration. It is good engineering practise to place it in a shaded position to prevent heating effects through solar radiation.

Conduit entries can accept connection for threaded rigid metal conduit or other wiring methods in accordance with Article 501 of the National Electrical Code ANSI/NFPA 70-latest version and IEC/EN 60079-14:latest version.

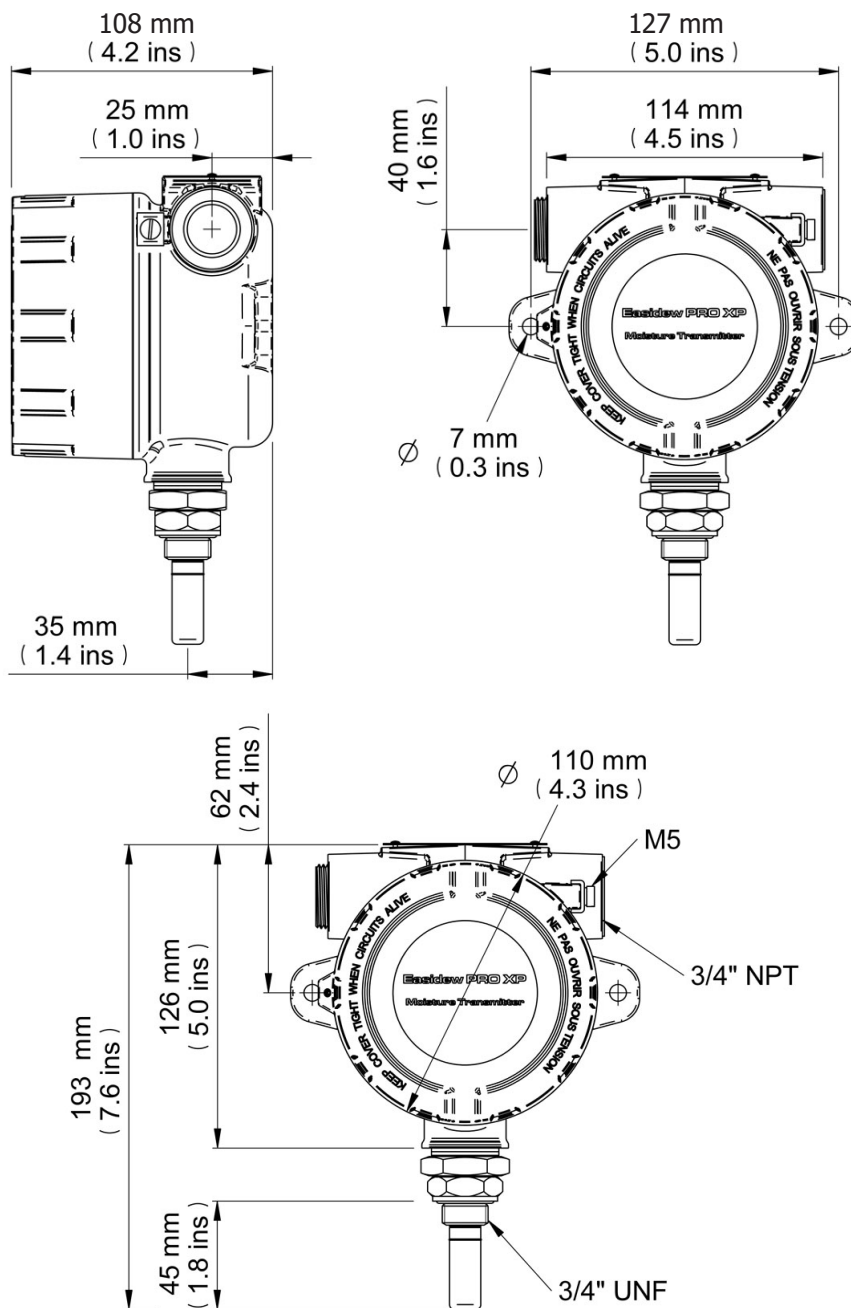

Figure 2 Dimensions Easidew PRO XP EX1 (Non-Display) - Wall Mounting

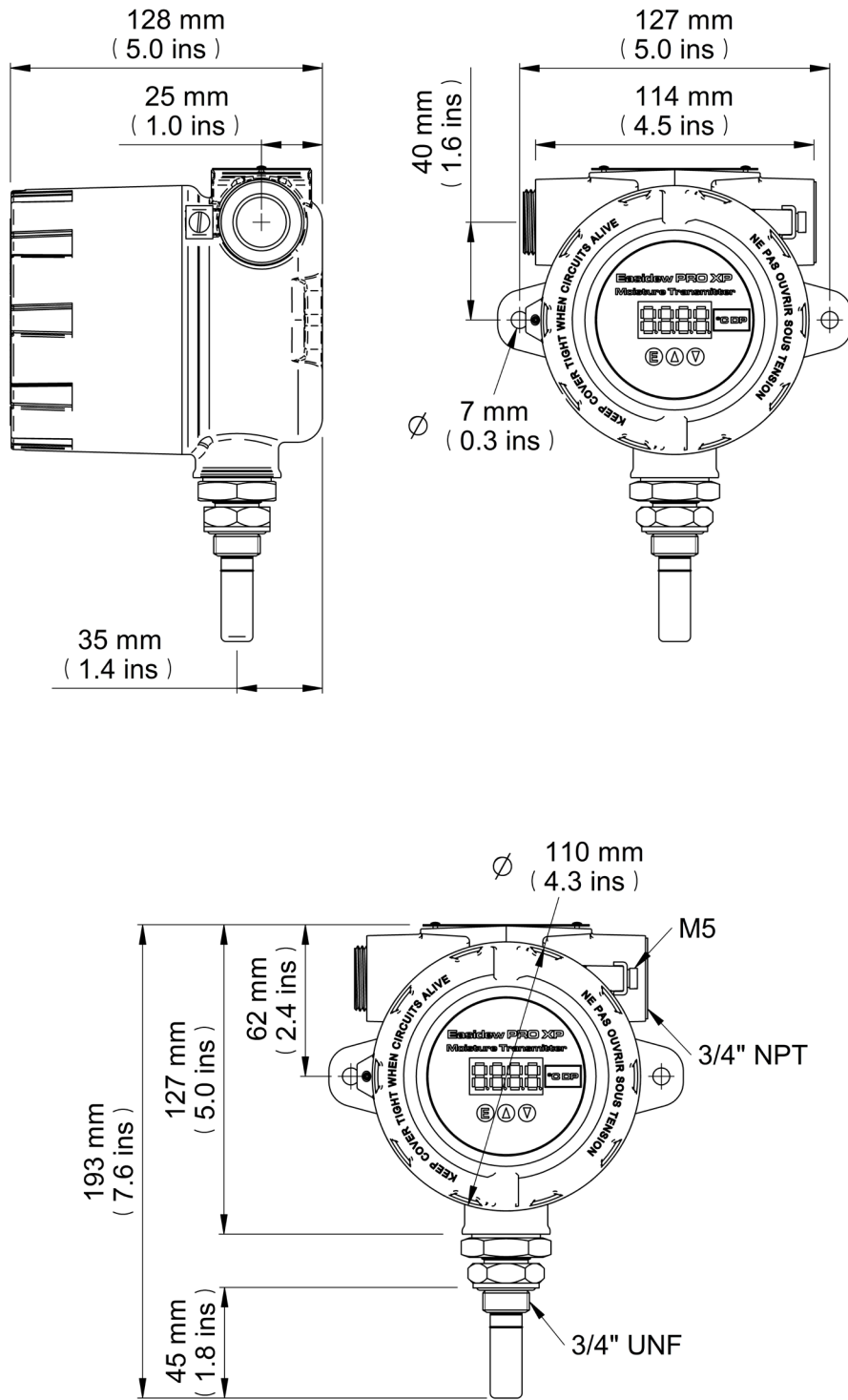

Figure 3 Dimensions Easidew PRO XP EX2 (Display) - Wall Mounting

2.1.2 Pipe Mounting

The Easidew PRO XP can be supplied with a pipe mounting bracket as an optional accessory, which allows the transmitter to be installed onto pipework up to 51mm (2") diameter.

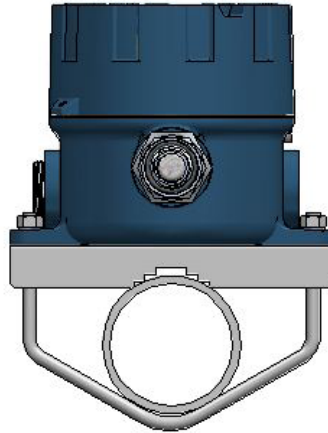

Figure 4 Transmitter Mounting - Pipe or Duct

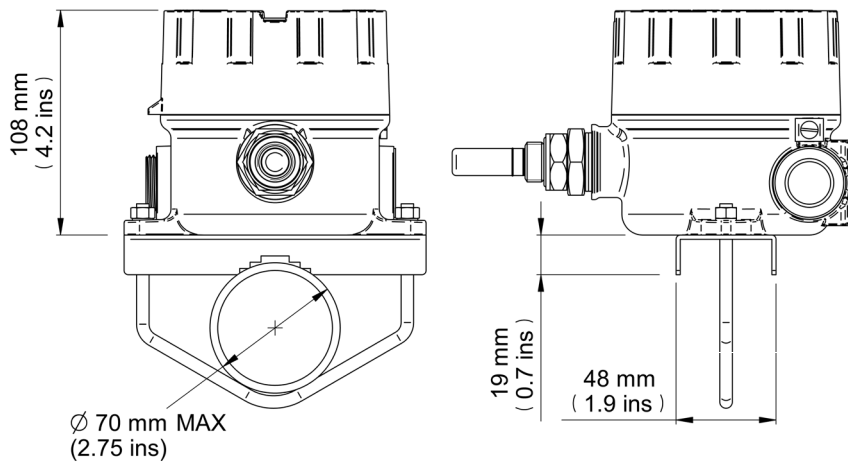

Figure 5 Dimensions Easidew PRO XP EX1 (Non-Display) - Pipe or Duct

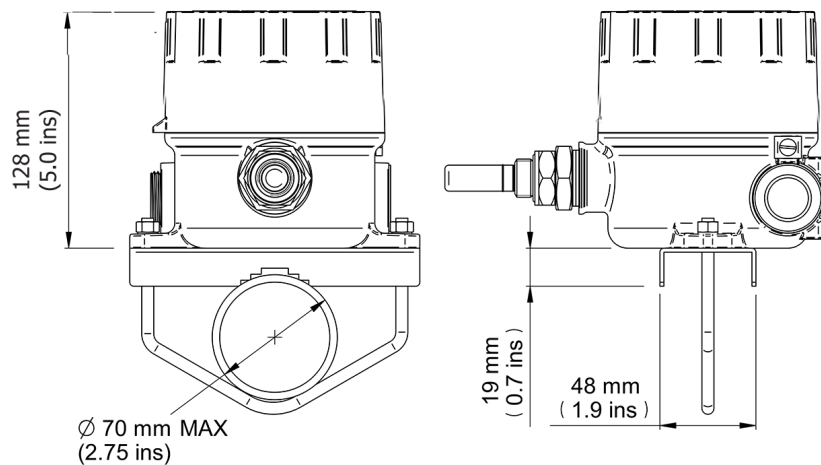

Figure 6 Dimensions Easidew PRO XP EX2 (Display) - Pipe or Duct

2.2 Gas Media Process Connection

The Easidew PRO XP transmitter can be mounted in any orientation for the following:

- inserted into a pipe or duct
- inserted into a flow-through sample block (optional).

It can be operated up to 45 MPa (450 barg/6500 psig) when fitted correctly.

If the installation is NOT into a Michell sample block please take note of the following to ensure correct installation is undertaken.



The following procedure must be carried out by a qualified engineer to ensure the safe operation of the pressure system.

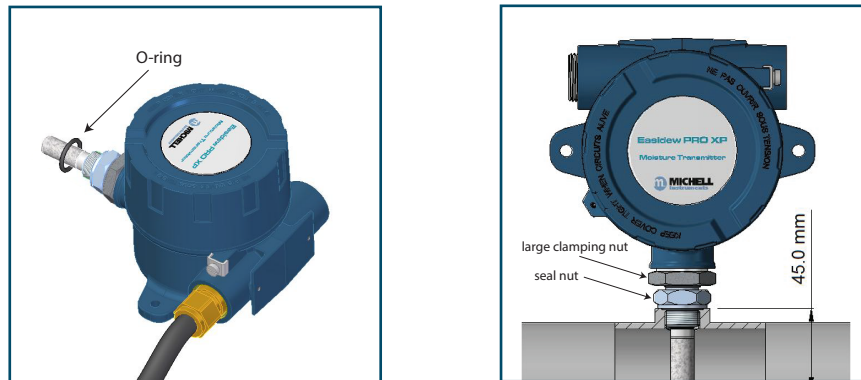

Figure 7 Transmitter Direct Mounting

1. Ensure the O-ring is located correctly within the O-ring groove of the process connection and that there is no contamination or debris on its exposed surfaces.
2. Ensure that the sealing face of the transmitter mounting is normal to the thread (0.08mm/25mm (0.003"/1")run).
3. Ensure that the O-ring mating sealing surface is 0.8 Ra (0.8µm) or better.
4. Ensure that the mating connection thread is cut to the correct size (¾" UNF x 16) with a minimum chamfer of 1mm (0.04").
5. Screw the transmitter into the sample block and, whilst holding the flats on the block, tighten the seal nut to 40Nm (29.5 lbf-ft) to compress the O-ring.

6. Rotate the enclosure to the desired position (up to 360° available) and tighten the large clamping nut (32mm 1¼") to 10Nm (7.4 lbf-ft) to ensure dowty seal is correctly compressed for environmental protection (see Appendix B.1).

The recommended fluid flow rate, when mounted in the optional sample block, is 1 to 5 l/min (2.1 to 10.6 scfh). However, for direct insertion applications, the flow can be from static to 10 m/sec (32.8 fps).



The Easidew PRO XP is fitted with a mechanical stop to prevent the accidental over-rotation of the enclosure assembly that would damage the internal sensor wiring.

2.3 Liquid Media Process Connection

When mounting the Easidew PRO XP into a liquid sample the flow rate must be between 0.1 and 0.3 l/min (0.2 and 0.6 scfh).

Consideration should be taken regarding draining the sample fluid at times when the transmitter needs to be removed for maintenance or calibration.

It would be beneficial for the Easidew PRO XP to be mounted in a vertical position (with the sensor pointing down) to allow for easy removal when necessary.

2.3.1 Sample Block (Optional)



The following procedure must be carried out by a qualified engineer to ensure the safe operation of the pressure system.

1. Remove the green protective cap and desiccant capsule.
2. Ensure the O-ring (see *Figure 8*) is located correctly within the O-ring groove of the process connection and there is no contamination or debris on its exposed surfaces.
3. Screw the transmitter into the sample block and, whilst holding the flats on the block, tighten the seal nut to 40Nm (29.5 lbf-ft) to compress the O-ring.
4. Rotate the enclosure to the desired position (up to 360° available) and tighten the large clamping nut (32mm 1¼") to 10Nm (7.4 lbf-ft) to ensure dowty seal is correctly compressed for environmental protection (see Appendix B.1).

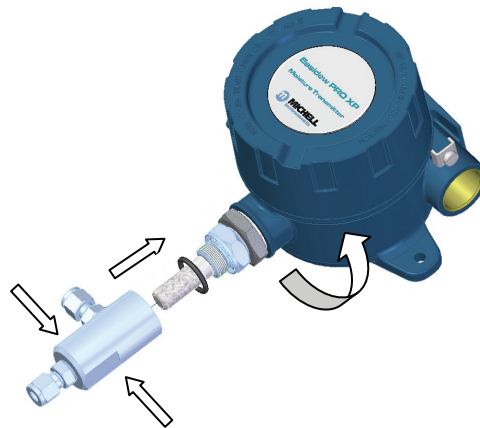

Figure 8 *Transmitter Mounting - Sample Block*

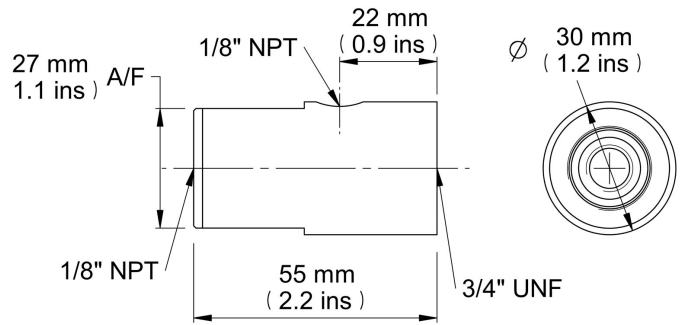

Figure 9 *Outline Dimensions - Sample Block*

2.3.2 Orientating the display

The display can be oriented at 90, 180, 270 or 360° intervals to the process connection. The procedure to change the orientation of the display is as follows:

- Unscrew the lid from the enclosure
- The display module is located onto two pillars mounted to the base
- Receivers on the underside of the display module are mounted at 90° intervals
- Choose the required display orientation, and ensure that the display is properly located onto the pillars
- Screw the lid back onto the enclosure

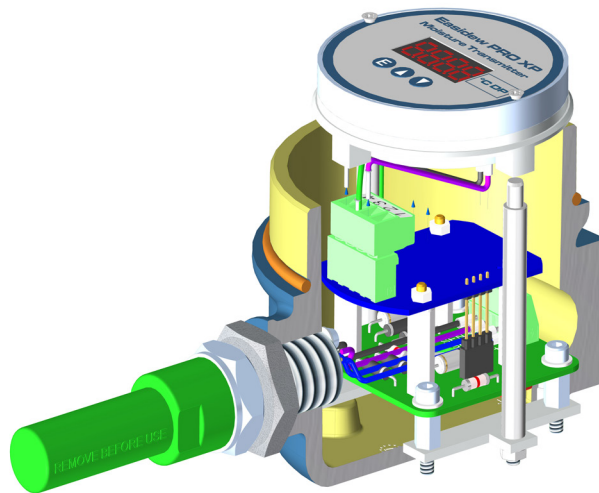

Figure 10 *Orientating the display*

2.4 Hazardous Area Safety

Appendix B of this manual refers to the Hazardous Area Certification of this product.

This product is fitted with a marking label that contains Hazardous Area information pertinent to the suitable location and installation.

During all installation and operation activities local regulations and permitted working routines must be observed. Installation should only be performed by competent personnel and in accordance with IEC/EN 60079-14:latest version or local equivalent.

This product is supplied with 1 off multi-national approved Exd Stopping Plug. Other suitably Exd approved Stopping Plugs may be used at the choice of the installer.

The installation of Easidew PRO XP will require the use of a suitably approved Exd rated Cable Gland. The Cable Gland is not supplied and the specific type/size must be selected at the choice of the installer and to suit the type of connecting cable used. The Cable Gland may be fitted to either of the Gland entry ports.

For the convenience of the installation process the Stopping Plug supplied is only loosely fitted so that it may finally be secured to the spare port opposite the Cable Gland after the Cable Gland installation has been completed. A Stopping Plug must be fitted to the spare port.

The Cable Gland and Stopping Plug must be tightly fitted without the use of any sealing tape or sealing compounds and in accordance with local regulations.

Cable glands / conduit seals shall be installed in accordance with the manufacturer's instructions.

Conduit seals used should be suitable for a reference pressure of 6.1 bar (89 psi).

Repair and servicing of this equipment must only be carried out by the manufacturer.

Supplied separately to the manual is an Installation and Maintenance Information Sheet.

WARNING:

This product is Certified safe for use in a Zone 1 & 21, and Zone 2 & 22 and Class I, Zone 1 and Class I, Division 1 area only. This product must not be installed or used within a Zone 0 area.

WARNING:

This product must not be operated within an explosive atmosphere greater than 1.1 bar absolute (16 psia).

**WARNING:**

This product must not be operated with enriched oxygen gas samples (more than 21% oxygen content).

WARNING:

This product must not be operated outside of the temperature range of -40 and +60°C (-40 and +140°F).

WARNING:

The enclosure of this product provides Exd protection, partly through the threads used for mounting the lid, stopping plugs and cable gland. At all times effort should be made to ensure these threads are suitably protected from damage and that only appropriately rated mating parts are applied to them, in accordance with the certifying requirements.

2.5 Electrical Safety

WARNING:
During the installation of this product ensure that all applicable national and local electrical safety regulations are observed.



WARNING:
Isolate the power prior to installation.

WARNING:
Always ensure that power is switched off prior to accessing the product for any purpose other than normal operation or prior to disconnecting any cables.

In compliance with IEC 61010 Electrical Safety Standard the following applies to this product:

2.5.1 Equipment Ratings and Installation Details

This equipment must be supplied with a voltage between the range of 14 to 28 V DC. Maximum power rating is 1 W.

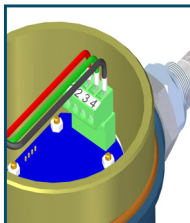

The power is connected via PL2 on the pcb.

The input and output connector is a 2-part pcb mounted type, rated at 300 V, 10 A.

The detachable, screw terminal half of each connector is designed to accept 0.5-2.5mm² [24 -12 AWG] (0.02-0.09²) stranded or solid conductors (non-display version only).

Any power connection cable should have a minimum 0.5mm (0.02²) insulation and be rated at 300 V. Ensure the power supply can deliver sufficient power consumption requirement.

Ensure any power supply terminals and voltages are suitably separated from the other I/O requirements of this product.

Before applying power, perform a continuity test to ensure that the power supply screen and product are effectively connected to the protective Earth.

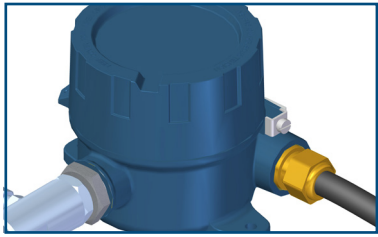

The protective Earth terminal is mounted externally and the Earth wire connected to it should never be disconnected. The product enclosure is supplied with a 5mm (0.2") diameter external Earth connection at the lower right hand side. At installation, connect this Earth connection to plant Earth by a minimum 4mm² (0.162") earthing bonding.

This product is designed, where applicable and possible, to be in compliance with EN/BS/IEC61010 safety requirements or electrical equipment or measurement, control, and laboratory use. This product is designed to be safe at least under the following conditions: between a temperature range of -5 to +40°C (+23 to +104°F), in maximum 80% relative humidity for temperatures up to +31°C (+88°F) decreasing linearly to 50% RH at +50°C (+122°F). Supply voltages of ±10% and transient over voltages up to Overvoltage Category II. Pollution Degree 2. Altitudes up to 2000m. Outdoor mounting is permitted using suitably rated glands equivalent to NEMA 4 / IP66. See Appendix A, Technical Specification, for full operating parameters.

NOTE: Do not remove or exchange any of the cables or electrical components supplied with this product. Doing so will invalidate all warranties.

Refer to the relevant sections of this manual for the location and mounting details.

Installation of this equipment should include the provision of a suitable and locally positioned power isolation switch or circuit breaker. Indication of the purpose of the switch or circuit breaker is strongly recommended. An over-current protection device should be rated to a maximum of 3 A.

Ensure this equipment and all power isolation devices are installed in a location and position that allows safe and easy access to their operation and is adequate to rigidly support the equipment.

Do not install this equipment in a location that would expose it impact or high levels of vibration.

Operation of this equipment, other than in a manner as specified by the manufacturer, may impair the safety protections provided.

The safe installation of this equipment and any system incorporating this equipment is the responsibility of the installer. Ensure local regulations and requirements are referred to prior to any installation commencing.

2.6 Pressure Safety



WARNING:
 This product is used in conjunction with pressurized gases. Observe pressurized gas handling precautions.



WARNING:
 Pressurized gas is dangerous. Pressurized gas should only be handled by suitably trained personnel.

The Easidew PRO XP requires pressurized gas to be connected to it. Observe pressurized gas handling regulations and only suitable trained personnel should carry out task that include the use of pressurized gas mediums.

DO NOT permit pressures greater than the safe working pressure to be applied to the instrument. The specified safe working pressure for this instrument is 450 barg (6525 psig) max.

2.7 Electrical Schematic

2.7.1 Easidew PRO XP EX1 (Non-Display)

NOTE: To ensure compliance with EMC standards, ensure that the screen of the power supply/signal cable or the power supply/signal conduit is connected to ground.

With the cable entry option, a conductive cable entry gland is recommended, allowing the transmitter housing to be earthed via the cable screen connection.



Always connect the 4-20 mA return signal to a suitable load (see Figure 15) before the power is applied. Without this connection, the transmitter may be damaged if allowed to operate for prolonged periods.

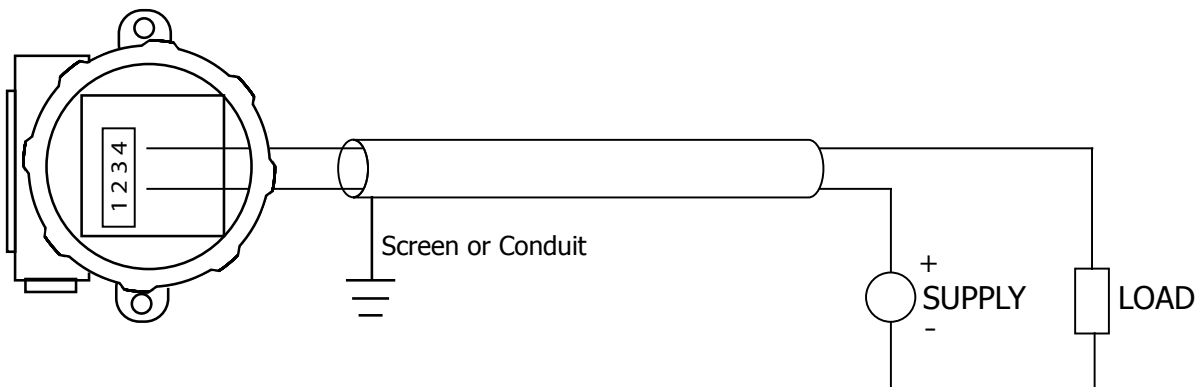

Figure 11 Electrical Schematic - Easidew PRO XP EX1 (Non-Display)

2.7.2 Easidew PRO XP EX2 (Display)

NOTE: To ensure compliance with EMC standards, ensure that the screen of the power supply/signal cable or the power supply/signal conduit is connected to ground.

With the cable entry option, a conductive cable entry gland is recommended, allowing the transmitter housing to be earthed via the cable screen connection.



Always connect the 4-20 mA return signal to a suitable load (see Figure 16) before the power is applied. Without this connection, the transmitter may be damaged if allowed to operate for prolonged periods.

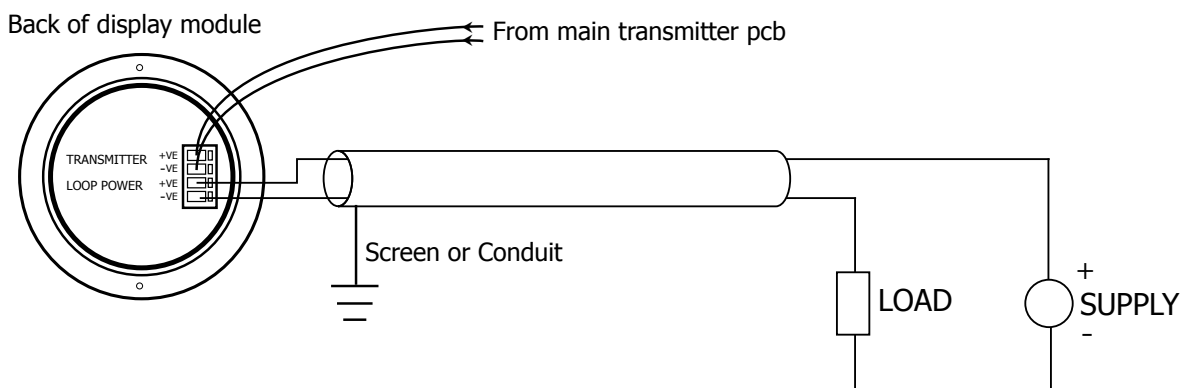

Figure 12 Electrical Schematic - Easidew PRO XP EX2 (Display)

2.7.3 Electrical Boundaries

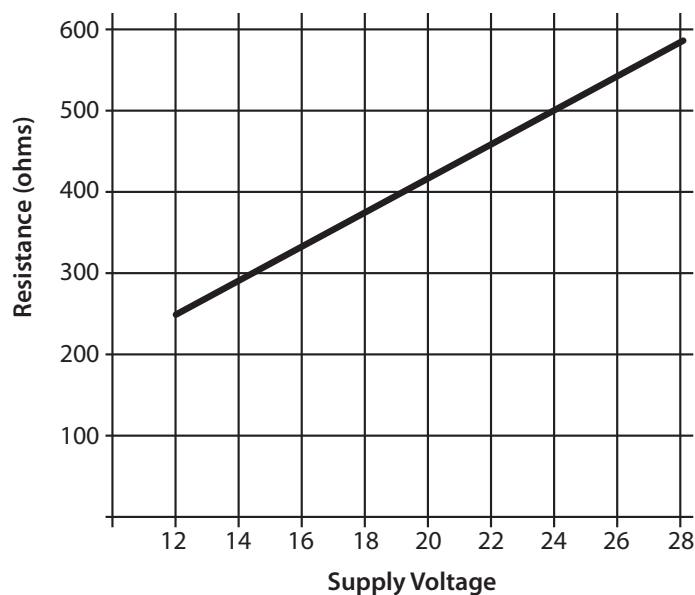

Figure 13 Maximum Load of Easidew PRO XP - Including Cable Resistance

2.8 Preparation of the Sensor Cable



The sensor cable is not supplied with the Easidew PRO XP, but there are 2 off bootlace ferrules supplied. Maximum conductor size is 0.75mm² (0.032").

Correct preparation of the cable conductors is essential to ensure a reliable connection to the sensor terminals.

1. Strip the insulation from each conductor to 8mm, without damaging any wire strands.
2. Using a crimp tool such as the CK 3682 (RS 343-8824), correctly attach each ferrule.

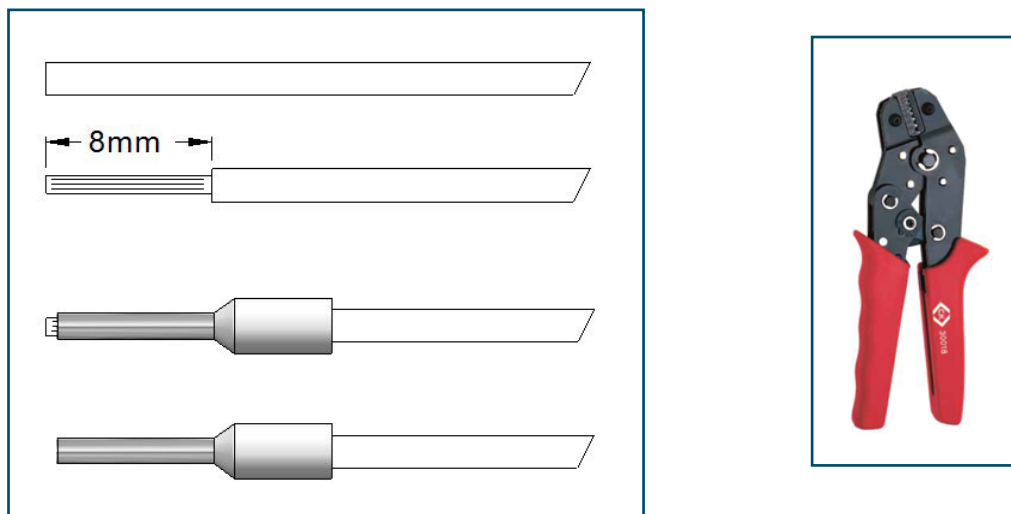

Figure 14 Wire and Crimp Details

2.8.1 Terminal Block Connection - Easidew PRO XP EX1 (Non-Display)

1. Remove the enclosure lid by carefully unscrewing anti-clockwise
2. Remove the 4-way terminal block from its header on the pcb, being careful not to put any strain onto the earth wire already attached.
3. Mount each of the power and return wires into positions 2 and 4 as shown, and tighten with a flat-blade screwdriver (min torque 0.25Nm (0.2 lbf-ft)).

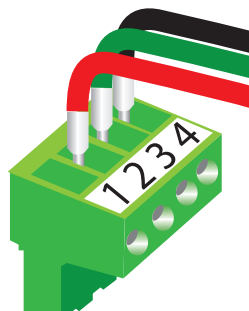

Figure 15 Terminal Block Connection - Easidew PRO XP EX1 (Non-Display)

4. Plug the terminal block back into the header.
5. Re-fit the enclosure lid in a clockwise direction until it stops and secure in place by tightening the grub screw with a 1.5mm (0.06") A/F Allen key.

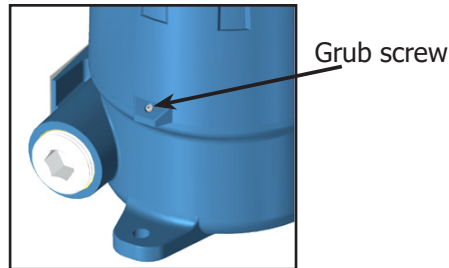
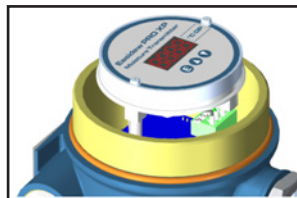

Figure 16 Grub Screw

2.8.2 Terminal Block Connection - Easidew PRO XP EX2 (Display)

1. Remove the enclosure lid by carefully unscrewing anti-clockwise.



2. Lift off the display meter and integral mounting bracket from the 2 mounting posts and disconnect the terminal block connector from the underside.

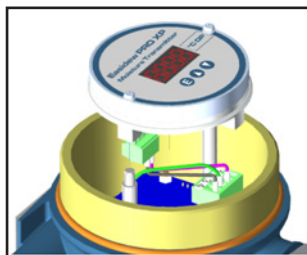

3. Mount each of the power and return wires into positions Loop Power +VE and Loop Power -VE as shown, and tighten with a flat bladed screwdriver (min torque 0.25Nm (0.2 lbf-ft)).

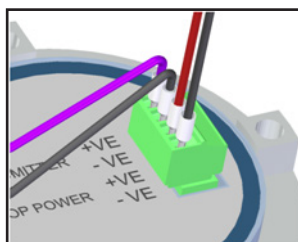

Figure 17 Terminal Block Mounting - Easidew PRO XP EX2 (Display)

4. Plug the terminal block back into the underside of the display meter and place it back onto its posts. Align the display meter in relation to the housing, as required.

5. Re-fit the enclosure lid in a clockwise direction until it stops and secure in place by tightening the grub screw with a 1.5mm (0.06") A/F Allen key.

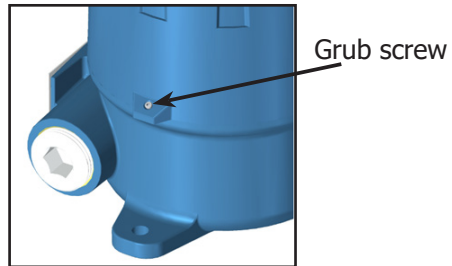

Figure 18 *Grub Screw*

3 OPERATION

3.1 Measurement and Configuration

The Easidew PRO XP can be configured to provide an output of 4-20 mA (2-wire connection) for the following:

Dew point	-110 to +20°C (-166 to +68°Fdp)
Moisture content in gas	0 - 3000 ppm _v (and equivalent mg/m ³ , lbs/MMSCF)
Moisture content in liquids	0 - 3000 ppm _w

The Easidew PRO XP is factory configured either as °Cdp (default) or °Fdp (North America). The Easidew PRO XP can be re-configured by the customer, using the Easidew XP Communications Kit (XP-CK) and Easidew Application Software. The Easidew Communications Kit can be purchased from Michell Instruments or a local representative. For a free copy of the Application Software contact Michell Instruments' UK office (see www.michell.com for details of Michell's contact information).

For moisture content in gas, the calculation from the measured dew point is assumed to be at atmospheric pressure. Alternatively, a fixed gas pressure needs to be programmed into the Easidew PRO XP.

For moisture content measurement in liquid, the Easidew PRO XP requires the saturation constant of the liquid to be programmed into the transmitters, either at the factory or by the customer using the Application Software.

The transmitter requires a 6-point look-up table for saturation constants up to 3000 ppm_w over the temperature range 0 to +50°C (+32 to +122°F). Saturation constants for 8 common liquids can be programmed into the Easidew PRO XP via the Application Software. Alternatively, the user can program saturation constants manually. The Application Software Help file provides detailed instructions on how to perform this task.

Easidew PRO XP EX2 (Display) Only

The display meter is simple in design and is a slave display to the measurement and configuration of the main transmitter pcb. It can be scaled linearly equating to the circulating 4-20 mA signal output from the main transmitter pcb.

In order to re-configure the display, the enclosure lid should be removed by unscrewing it in an anti-clockwise direction.



Care should be taken when unscrewing and replacing the enclosure lid as the threads form an important part of the Ex compliance regulations and therefore must not be damaged.

The lid must be replaced after using the display meter and the grub screw tightened.

A full explanation of the operation and configuration of the integral display meter is detailed in Appendix D.

3.2 Sampling Hints

Operation is very simple, assuming the following installation techniques are adhered to:

Be Sure the Sample is Representative of the Gas Under Test:

The sample point should be as close to the critical measurement point as possible. Also, never sample from the bottom of a pipe as entrained liquids may be drawn into the sensing element.

Minimize Dead Space in Sample Lines:

Dead space causes moisture entrapment points, increased system response times and measurement errors, as a result of the trapped moisture being released into the passing sample gas and causing an increase in partial vapor pressure.

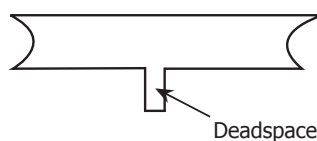

Figure 19 *Indication of Dead Space*

Remove Any Particulate Matter or Oil from the Gas Sample:

Particulate matter at high velocity can damage the sensing element and similarly, at low velocity, they may 'blind' the sensing element and reduce its response speed. If particulate, such as degraded desiccant, pipe scale or rust is present in the sample gas, use an in-line filter, as a minimum level of protection. For more demanding applications Michell Instruments offers a range of sampling systems (for more information contact www.michell.com).

Use High Quality Sample Tube and Fittings:

Michell Instruments recommends that, wherever possible, stainless steel tubing and fittings should be used. This is particularly important at low dew points since other materials have hygroscopic characteristics and adsorb moisture on the tube walls, slowing down response and, in extreme circumstances, giving false readings. For temporary applications, or where stainless steel tubing is not practical, use high quality thick walled PTFE tubing and work within the maximum pressure rating of this tubing.

Position Transmitter away from Heat Source:

It is recommended, as good instrumentation practice, that the transmitter is placed away from any heat source to avoid adsorption/desorption (particularly solar radiation during daylight hours).

4 MAINTENANCE



The power to the enclosure must be turned off before any work is carried out in the measurement system enclosure.

Observe de-energize durations.

Gas line connections to the measurement system must be isolated and de-pressurized before any work commences.

4.1 Calibration

Routine maintenance of the Easidew PRO XP is confined to regular re-calibration by exposure of the transmitter to sample gases of known moisture content to ensure that the stated accuracy is maintained. Calibration services traceable to the UK *National Physical Laboratory* (NPL) and the US *National Institute of Standards and Technology* (NIST) are provided by Michell Instruments.

Michell Instruments offers a re-calibration service to suit specific needs. A Michell representative can provide detailed, custom advice (for Michell Instruments' contact information go to www.michell.com).

4.2 Sensor Guard Replacement

The sensor is supplied with either a stainless steel sintered or HDPE guard.

The stainless steel guard provides $>80\mu\text{m}$ protection to the dew-point sensor, whereas the HDPE protects to $>10\mu\text{m}$. It is designed to show any contamination and the guard should be changed if the surface becomes discolored.

When replacing the guard, care should be taken to minimize touching the guard which should be handled by the threaded part. Replacement guards can be obtained by contacting Michell Instruments (www.michell.com) or your local distributor.

Please note the sensor tile should not be touched.

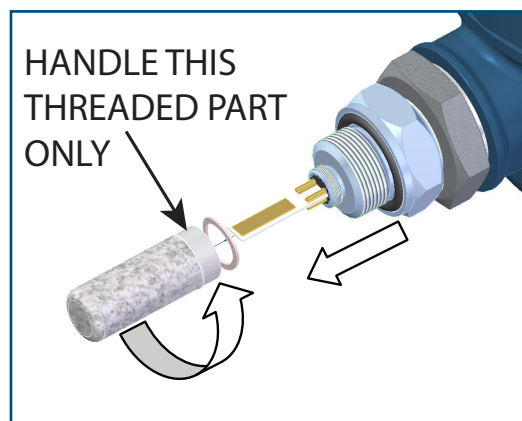

Figure 20 Replacement of Sensor Guard

4.3 Display Replacement

1. Unscrew the locking screw on the enclosure cap with a 1.5mm A/F Allen key.
2. Unscrew the cap, lift the display and mounting ring clear from the 2 off mounting pillars, and unplug the connector.



3. Remove the 2 off small screws holding the display onto its mounting ring. Lift the display clear.

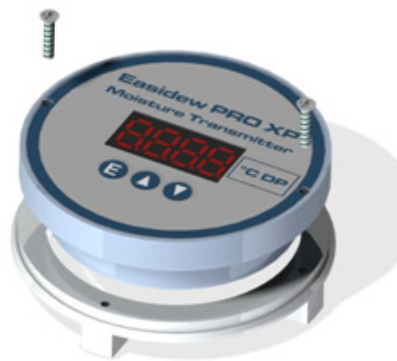

4. Re-assemble as above, in reverse order, being careful not to overtighten the screws. Ensure that the connector is fully mated.
5. Re-fit the enclosure cap and tighten the locking screw.
6. The display is supplied with a default configuration. Refer to Appendix D.4 'Re-configuration Steps' if required.

4.4 O-Ring Replacement



Do not touch the filter with bare hands

1. Identify the O-ring to be removed, as shown below.

BS116 (3/4" x 3/32") viton,
75 shore

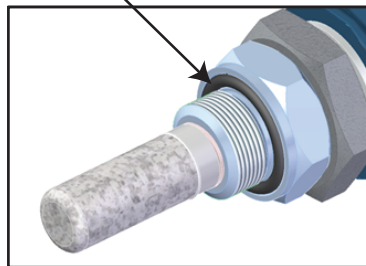

2. Carefully slide tweezers, thin bladed screwdriver or a blunt needle under the outer edge of the O-ring. **NOTE: Take care not to scratch any of the surfaces of the surrounding metal component.**
3. Move the tool around the circumference to assist the extraction process. Slide the O-ring clear of the thread and filter.

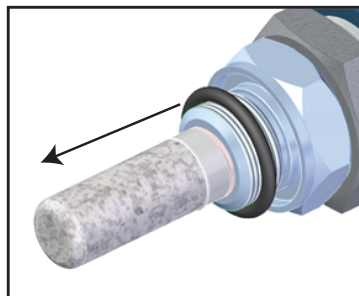

4. Make sure the groove has no scratches and is free from grease, dirt or debris. Slide the new O-ring over the filter and thread and into the groove. **NOTE: Do not touch the filter with bare hands.**

Appendix A

Technical Specifications

Appendix A Technical Specifications

Performance Specifications	Easidew PRO XP for Gases	Easidew PRO XP LQ for Liquids
Measurement range	-110 to +20°C dew point; -100 to +20°C dew point	0 to 1000 ppm _w ; Non-standard available on request
Accuracy	±1°C dew point (+20 to -60°C); ±2°C dew point (-60 to -110°C)	
Response time	5 mins to T95 (dry to wet)	
Repeatability	0.5°C dew point	
Calibration	Traceable 13 point calibration and certificate	
Electrical Specifications		
Output signal	4–20 mA (2-wire connection, current source); User configurable over range	
Output	Dew point or moisture content	Moisture content
Analog output scaled range	Dew point: -110 to +20°C; Moisture content in gas: 0–3000 ppm _v , Non-standard: mg/m ³ , lbs/MMSCF natural gas	Moisture content in liquid: 0–1000 ppm _w Non-standard available upon request
Supply voltage	14 to 28 V DC	
Load resistance	Max 250 Ω @ 14 V (500 Ω @ 24 V)	
Current consumption	23 mA max, depending on output signal	
Saturation constants (for moisture in liquids measurements only)	6-point look-up table for saturation constants up to 1000 ppm _w over the temperature range 0 to +50°C; saturation constants for 8 common liquids can be programmed into the Easidew PRO XP LQ via the application software; alternatively the user can program saturation constants manually	
CE conformity	2004/108/EC, 94/9/E ATEX directive	
Operating Specifications		
Operating temperature	-40 to +60°C	
Compensated Temperature Range	-20 to +50°C NOTE: The transmitter accuracy statement is only valid for the temperature range: -20/+50°C	
Storage Temperature	-40 to +60°C	
Operating pressure	45 MPa (450 barg) maximum	
Flow rate	1 to 5 NI/min mounted in standard sampling block; 0 to 10 m/sec direct insertion	0.1 to 0.3L/min through Easidew sample block 0.1 to 1m/s direct insertion
Mechanical Specifications		
Ingress protection	IP66 in accordance with standard BS EN 60529:1992; NEMA 4 protection in accordance with standard NEMA 250–2003	
Explosion and flameproof area certificates	<p>ATEX: Standard: Aluminium II 2 GD Exd [ia] IIC T6 Gb Ex tb IIIC T80°C Db IP66 Tamb -20°C to +70°C</p> <p>IECEX: Exd [ia] IIC T6 Gb Ex tb IIIC T80°C Db IP66 Tamb -20°C to +70°C</p> <p>cCSAus: CLS I, Div1, GRPS ABCD CLS II & III, Div1, GRPS EFG CLS I, Zone 1 AEx/Exd [ia] IIC T6</p> <p>INMETRO (Brazil): Zone 21, AEx/Ex tb IIIC T80°C Tamb = -20°C to +70°C IP66 [Approval codes as per IECEX]</p>	<p>Optional: 316 stainless steel II 2 GD Exd [ia] IIC T6 Gb Ex tb IIIC T80°C Db IP66 Tamb -20°C to +70°C</p> <p>Exd [ia] IIC T6 Gb Ex tb IIIC T80°C Db IP66 Tamb -20°C to +70°C</p> <p>CLS I, Div1, GRPS ABCD CLS II & III, Div1, GRPS EFG Tamb = -20°C to +70°C IP66</p> <p>TC TR EX-Certifi cate: 1Ex d [ia] IIC T6 Gb X Ex tb IIIC T80°C Db X Tamb -20°C to +70°C (Russia, Belarus, Kazakhstan)</p>
Russian pattern approval	Pending: Russia (GOST-R), Kazakhstan (GOST-K)	
Canadian pressure vessel cert	C.R.N. - all Canadian provinces	
Oxygen Service	Optional: cleaned for enriched oxygen	
Housing material	Standard: Aluminium (copper free), epoxy and polyurethane powder coated, blue RAL 5009 Optional: 316 stainless steel (supplied with BS EN 10204 3.1 material certificate if option F2 requested) (ATEX, IECEX & cCSAus)	
Housing moisture protection	Optional: Electronics Conformal Coating	
Filter (sensor protection)	Standard: Stainless steel sintered guard (for protection against fine particulate >80µm) Optional: HDPE guard (for protection against fine particulate >10µm)	
Process connection and material	3/4" — 16 UNF with recessed Viton® O-ring; 316 stainless steel	
Weight	Aluminium: 1.6kg; 316 stainless steel: 2.4kg	
Electrical connections	Dual 3/4" NPT gland	
Programmable display meter range	Optional: -1999 to +9999	
Programmable display decimal point	Optional: 0 to 3 decimal places	
Display meter overload limits	Optional: 3.6 mA and 20.4 mA	
Programmable display meter scales	Optional: °C, °F, %, No Scale	
Stainless Steel tags	Optional: 316 stainless steel tags (70 x 25mm)	
Diagnostic conditions (factory programmed)	<p>Conditions</p> <p>Sensor fault</p> <p>Under-range dew point</p> <p>Over-range dew point</p>	<p>Output</p> <p>23 mA</p> <p>4 mA</p> <p>20 mA</p>

Appendix B

Hazardous Area Certification

Appendix B Hazardous Area Certification

The Easidew PRO XP is certified compliant to the ATEX Directive (2014/34/EU) and IECEx for use within Zone 1 & 2 and Zone 21 & 22 Hazardous Areas and has been assessed so by SIRA Certification (Notified Body 0518).

The Easidew PRO XP is certified compliant to the North American Standards (USA and Canada) for use within Class I, Division 1, Groups A, B, C & D, Class II and III, Division 1, Groups E, F & G, Class I, Zone 1 & Zone 21 Hazardous Locations and has been assessed so by cCSAus.

B.1 Product Standards

This product conforms to the Standards:

EN60079-0:2012	IEC 60079-0:2011
EN60079-1:2007	IEC 60079-1:2007
EN60079-11:2012	IEC 60079-11:2011
EN60079-31:2009	IEC 60079-31:2008
C22.2 No. 0-M10	CAN/CSA-C22.2 No. 60079-0:11
C22.2 No. 25-1966	CAN/CSA-C22.2 No. 60079-1:11
C22.2 No. 30-M1986	CAN/CSA-C22.2 No. 60079-11:11
C22.2 No. 142-M1987	CAN/CSA-C22.2 No. 60079-31:12
C22.2 No. 157-92	ISA 60079-0:11
FM Class 3600	ISA 60079-1:09
FM Class 3610	ISA 60079-11:11
FM Class 3615	ISA 60079-31:12
FM Class 3616	UL 916-2003

B.2 Product Certification

This product is attributed with the product certification code:

ATEX & IECEx
II 2 GD Exd [ia] IIC T6 Gb
Ex tb IIIC T80°C Db IP66 (-20°C to +70°C)

North American (Aluminium enclosure)
Class I, Division 1, Groups A,B,C,D
Class II & III, Division 1, Groups E,F,G
Class I, Zone 1 AEx/Ex d [ia] IIC T6
Zone 21, AEx/Ex tb IIIC T80°C

North American (Stainless Steel enclosure)
Class I, Division 1, Groups ABCD
Class II, Division 1, Groups EFG
Class III, Division 1

B.3 Global Certificates/Approvals

ATEX	SIRA14ATEX1007X
IECEX	IECEX SIR 14.0004X
cCSAus	2679645
INMETRO	NCC 14.03240 X
TC TR Ex	RU C-GB.ГБ05.B.00833

These certificates can be viewed or downloaded from our website at:
<http://www.michell.com>

B.4 Special Conditions

1. The equipment has been assessed with a U_m of 28V and shall be installed in accordance with the latest installation requirements of IEC/EN 60079-14 for intrinsically safe equipment for EPL "Gb".
2. The transmitter shall not be installed in such a manner that the sensing probe is in a dust environment.
3. WARNING - POTENTIAL ELECTROSTATIC CHARGING HAZARD. The equipment must only be wiped with a damp cloth.
4. When installing the transmitter a torque of 10 Nm must be applied to the sensor body/housing positioning lock nut to secure it. See manufacturer's instructions for further details.

B.5 Maintenance and Installation

The Easidew PRO XP must only be installed by suitably qualified personnel and in accordance with the instructions provided and the terms of the applicable product certificates.

Maintenance and servicing of the product must only be carried out by suitably trained personnel or returned to an approved Michell Instruments' Service Center.

Appendix C

Fully Programmable Loop Powered 4-Digit LED Display Meter

Appendix C Fully Programmable Loop Powered 4-Digit LED Display Meter

In order to re-configure the display meter, the enclosure lid should be removed by unscrewing it in an anti-clockwise direction.



Care should be taken when unscrewing and replacing the enclosure lid as the threads form an important part of the Ex compliance regulations and therefore must not be damaged.

The lid must be replaced after using the display meter, and the grub screw tightened.

C.1 Display Meter Parameter Limits

The programmable display meter is designed for current loops of 4-20 mA. It is powered from the loop and does not require any other supply. The display can be configured by set-up menus to show physical values measured by the sensor.

Display will indicate low (-LO-) when the input current is lower than the overload limit (3.6 mA).

Display will indicate high (-HI-) when the input current is higher than overload limit (20.4 mA).

Display will indicate (----) when displayed value is <1999 or >9999.

C.2 Display Meter Operating Range

Operating Range	from 3.6 to 20.4 mA
Maximum Voltage Drop Out	3.7 V
Display LED	4 digits, height 9.5mm
Indication Limits	from -1999 to 9999
Variable Sampling Time	from 1 to 10 seconds

C.3 Display Meter View



C.4 Re-Configuration Steps

To enter menu press the E button for 2 seconds.

Displayed Text	Description
DP	Setting decimal point DP Press E button Press ▲ and ▼ buttons to change decimal position 1.234 (value 3) 12.34 (value 2) 123.4 (value 1) Factory default 1234 to decimal point (value 0)
	Press E button. Press ▼ to go to Zero Setting

Displayed Text	Description
Zero	Setting low limit Zero (set-up of the low limit) Press E button Press ▲ and ▼ buttons to change the value between -1999 and 9999 <i>(the value chosen will be displayed at input current of 4 mA-point low)</i>
	NOTE: For 1 decimal place resolution set this value to 10 times the actual required value, e.g. -1000 for -100.0 / -1100 for -110.0 Press E button. Press ▼ to go to Span Setting

Displayed Text	Description
SPAN	Setting high limit SPAN (setup of the high limit) Press E button Press ▲ and ▼ buttons to change the value between -1999 and 9999 <i>(the value chosen will be displayed at input current of 20 mA-point high)</i>
	NOTE: For 1 decimal place resolution set this value to 10 times the actual required value, e.g. 200 for 20.0 Press E button. Press ▼ to go to Li Setting

Displayed Text	Description
Li	Setting overload limit Li (set-up of the overload limit) Press E button Press ▲ and ▼ buttons to change the value 0 for 4-20 mA the display shows -LO- when current < 4 mA and -HI- when current >20 mA 1 for 3.6 mA - 20.4 mA Factory default the display shows -LO- when current <3.6 mA -HI- when current >20.4 mA Press E button. Press ▼ to go to St Setting

Displayed Text	Description
St	<p>Setting sampling rate St Press E button Press ▲ and ▼ buttons to change the sampling rate from 1 to 10 seconds 1 = Factory default Press E button. Press ▼ to go to Engineering Unit</p>

Displayed Text	Description
Unit	<p>Set-up Engineering Unit Press E button Press ▲ and ▼ buttons to select the unit - nonE - for no unit on the display (factory default setting) see D.5 - °C, °F, K, % <i>(There is a 6 second cycle - measured value is displayed for 4 seconds - the unit is displayed for 2 seconds)</i> Press E button</p>

Exit from menu and save settings:

Press ▲ and ▼ buttons (possible from each page)

C.5 Moisture Scaling Label

The Easidew PRO XP has 3 standard ranges and scales which are as follows:

EA-XP-TX -110 to +20°Cdp output range
 -100 to +20°Cdp output range

EA-XP-LQ-TX 0-1000ppm_w

The EA-XP-TX units will be configured for the range/scale ordered (as above) and will constantly display the measured value. The display meter will have a stick-on label defining the scale in °C DP.

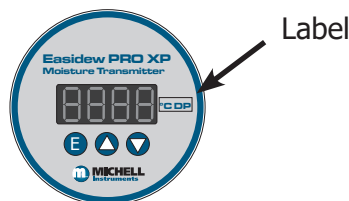

If ordered with a non-standard range/scale the unit could be set up with the following:

- °F DP
- lbs/MMSCF
- ppm_v
- ppm_w
- mg/m³

Alternatively, an Easidew PRO XP Communication Kit (XP-CK) can be used to change the range/scale and this Kit will be shipped with its own manual and 2 additional sets of scaling labels so that the label can be changed as required.

C.6 Technical Specifications - EX2 LED Display

The display meter is simple in design and is a slave display to the measurement and configuration of the main transmitter pcb. It can be scaled linearly equating to the circulating 4-20 mA signal output from the main transmitter pcb.

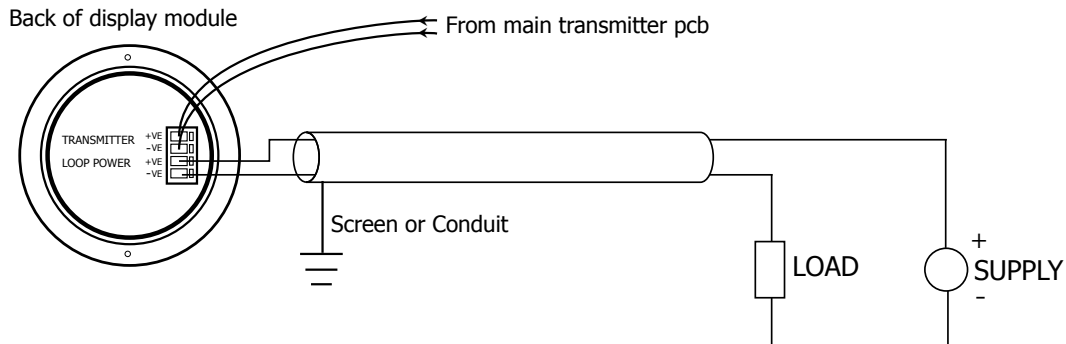

Performance	
Reference Operating Condition	25°C
Maximum Measured Error	0.1% of the programmed range \pm 1 digit
Influence of Ambient Temperature (temp drift)	20 ppm / °C of measuring range at 20°C as reference temperature
Output Signal	4-20 mA
Supply Voltage	24 V (10 to 30 V)
Voltage Drop Out	3.3 V at 4 mA and 3.7 V at 20 mA
Minimum Current of LED Activation	3.6 mA
Digits	LED, 4 digits 7 segments, height 9.5mm
Display Characteristics	6400ucd for $I_f=10$ mA
Storage Period	10 years (non-powered)
Operating Conditions	
Ambient Temperature	-20 to +80°C (-4 to +176°F)
Storage Temperature	-30 to +80°C (-22 to +176°F)
Functionality	
Parameters	Zero, span, decimal, point, refresh rate, unit
Indication Limit	-1999 to +9999
Programmable Range	-1999 to +9999
Decimal Points Position	0, 1, 2, 3 decimals
Overload Limits	From 3.6 to 20.4 mA
Refresh Rate	From 1 to 10 seconds
Unit	°C, °F, K, % in cycle: 4 second value - 2 second unit
Mechanical Construction	
Electrical Loop Connection	2 terminals, max wire section 1mm ² (16 AWG)

Appendix D

Quality, Recycling & Warranty Information

Appendix D Quality, Recycling & Warranty Information

Michell Instruments is dedicated to complying to all relevant legislation and directives. Full information can be found on our website at:

www.michell.com/compliance

This page contains information on the following directives:

- ATEX Directive
- Calibration Facilities
- Conflict Minerals
- FCC Statement
- Manufacturing Quality
- Modern Slavery Statement
- Pressure Equipment Directive
- REACH
- RoHS2
- WEEE2
- Recycling Policy
- Warranty and Returns

This information is also available in PDF format.

Appendix E

Return Document & Decontamination Declaration

Appendix E Return Document & Decontamination Declaration

Decontamination Certificate

IMPORTANT NOTE: Please complete this form prior to this instrument, or any components, leaving your site and being returned to us, or, where applicable, prior to any work being carried out by a Michell engineer at your site.

Instrument			Serial Number	
Warranty Repair?	YES	NO	Original PO #	
Company Name			Contact Name	
Address				
Telephone #		E-mail address		
Reason for Return /Description of Fault:				
Has this equipment been exposed (internally or externally) to any of the following? Please circle (YES/NO) as applicable and provide details below				
Biohazards	YES	NO		
Biological agents	YES	NO		
Hazardous chemicals	YES	NO		
Radioactive substances	YES	NO		
Other hazards	YES	NO		
Please provide details of any hazardous materials used with this equipment as indicated above (use continuation sheet if necessary)				
Your method of cleaning/decontamination				
Has the equipment been cleaned and decontaminated?	YES	NOT NECESSARY		
Michell Instruments will not accept instruments that have been exposed to toxins, radio-activity or bio-hazardous materials. For most applications involving solvents, acidic, basic, flammable or toxic gases a simple purge with dry gas (dew point <-30°C) over 24 hours should be sufficient to decontaminate the unit prior to return. Work will not be carried out on any unit that does not have a completed decontamination declaration.				
Decontamination Declaration				
I declare that the information above is true and complete to the best of my knowledge, and it is safe for Michell personnel to service or repair the returned instrument.				
Name (Print)			Position	
Signature			Date	





<http://www.michell.com>