



Merlin

Universal Indicator

- › Universal input
- › 22V excitation
- › Smart, simple, USB powered setup
- › Optional relay outputs
- › Optional isolated analog output
- › Designed for harsh environments
- › Large 0.8" super-bright display
- › Flexible 32 point linearization table



General Description

The Merlin universal digital indicator accepts analog inputs from a range of industrial sensors, including: process, temperature, flow, frequency, and voltage from 200mV to 300V. It features a wide range power supply that suits both AC mains and 24V DC applications, and supplies the excitation required for common sensors and transmitters.

The Merlin can be scaled into any engineering unit, and the result displayed on the large 0.8" 4 digit super-bright LED display. Auto ranging is available to increase the dynamic range of viewable data.

The Merlin R2A adds two Form A 3 Amp relays for a variety of control and alarm functions, and a 4-20mA active output for retransmission to PLCs and SCADA systems.



The unit boasts a 1 minute setup time using the Define Toolbox configuration software. All functions are explained expertly in the dynamic sidebar help - perfect for the novice starting out who can use it to learn about industrial applications, or the expert who wants to save commissioning time.

The Merlin has been designed for harsh industrial environments. With an IP65 sealed bezel and extensive testing of noise effects to and beyond CE requirements, the meter provides a tough and reliable application solution.

Quick start

1 **Hardware Install** (p6)

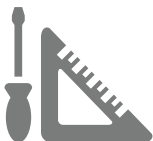

2 **Software Install** (p7)



3 **Software Setup** (p9)



4 **Wiring** (p12)



CONTENTS

Contents	2	5.4 - Power Supply	13
Order Codes	2	5.5 - Sensor Input	14
Safety Notices	3	5.6 - Analog Output	14
Symbol Definitions	3	5.7 - Relay Outputs	14
1 - Specifications	3	5.8 - User Input	14
1.1 - General Meter Specifications	3	6 - Input Types	15
1.2 - Display	5	6.1 - Thermocouple Input	15
1.3 - Case Dimensions	5	6.2 - RTD Input	16
2 - Hardware Installation	6	6.3 - NTC Input	17
2.1 - Installation Instructions	6	6.4 - Current Input	18
2.2 - Installation Environment	6	6.5 - Voltage Input	19
3 - Software Installation	7	6.6 - Digital Pulse	21
4 - Software Configuration	9	6.7 - Potentiometer Input	22
Using ToolBox		6.8 - AC Current Sensor	23
4.1 - Bridge Key	9	7 - Maintenance & Service	24
4.2 - Using ToolBox	10	7.1 - Calibration	24
4.3 - ToolBox Interface Overview	11	7.2 - Troubleshooting	24
5 - Wiring	12	7.3 - Service	25
5.1 - Wiring Overview	12	A - Appendix A - EMC Test Results	25
5.2 - EMC Installation Guidelines	12	B - Appendix B - Warranty &	27
5.3 - Back Panel	13	User's Responsibility	

ORDER CODES

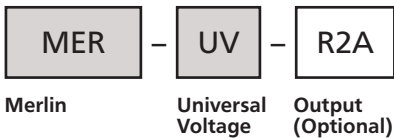

Merlin	MER	Universal Indicator
Universal Voltage	UV	24–250V AC / 19.5–250V DC
Output	R2A	2 x relay outputs, 1 x analog output (4–20mA)

SAFETY NOTICES



For your safety and the prevention of damage to the Merlin unit and other equipment connected to it, **please read complete instructions prior to installation and operation of the Merlin, and carefully observe all safety regulations and instructions. Consult this manual carefully in all cases where hazard symbols are marked on your Merlin unit.**



Use of this instrument in a manner not specified by the manufacturer may compromise the protection provided by the instrument. This instrument should not be used to directly drive valves, motors, or other actuators, unless equipped with appropriate safeguards.

It is the responsibility of the user to identify potential hazards that may arise in the event of a fault to unit, and implement safeguards for the prevention of harm to persons or equipment. The safety of any system incorporating this unit is the responsibility of the assembler of the system.

Symbol definitions



CAUTION
Risk of electric shock
Please refer to user manual.



Both direct and alternating current.



CAUTION
Risk of danger
Please refer to user manual.



Equipment protected throughout by DOUBLE INSULATION or REINFORCED INSULATION.

1

SPECIFICATIONS

1.1 - General meter specifications

Power

Power supply 24–250V AC / 19.5–250V DC, 47–63Hz, 6VA max

Isolation 2,300Vrms for 1min to all inputs and outputs

Analog input

Input Universal (see Section 6 for full input specifications and wiring)

Excitation power

Excitation 22V \pm 10% (25mA max)

Relay output**OPTIONAL****Type** 2x Form A relays**Isolation to sensor and user input commons** 2,300Vrms for 1min
Working voltage 240Vrms**Contact rating**

One Relay energized: 3amps @ 120/240V AC or 28V DC (resistive load)

3amps max total current with both relays energized

Life expectancy 100K cycles min at full load rating

User input**OPTIONAL****One user input** is available on R2A model only. It can be programmed for manual relay reset, latching or zero functions**Max continuous input** 20V DC**Isolation to sensor input common**

Not isolated

Analog output**OPTIONAL****Type** 1x 4–20mA or 20–4mA DC**Isolation to sensor and user input commons** 1,400Vrms for 1min
Working voltage 125V**Max output drive** 20mA (600Ω max load at 12V DC)**Accuracy/repeatability** 0.05% of FSO**Resolution** 1μA**Temperature drift** 30ppm/°C typical**Powered** Self-powered (active)

Environmental conditions**Operating humidity** 5–85%RH max (non-condensing)**Operating temperature** 14 to 122°F (-10 to 50°C)**Storage temperature** -4 to 140°F (-20 to 60°C)**Altitude** Up to 6561ft (2,000m)

Certifications & compliances**EN 61326-1** Immunity to Industrial Locations**Emission** CISPR 11 Class A (EN 61326)**Safety requirements for electrical equipment for measurement control, and laboratory use:***EN 61010-1* General Requirements*EN 61010-2-030* Particular Requirements for Testing and Measuring Circuits**UL Listed** File Number E473114**IP65** Enclosure rating (face only)

Construction**Panel mount enclosure** Rated for IP65 indoor use. Installation Category II, Pollution Degree 2. Flame resistant. Panel gasket and mounting clips included.**Dimensions**

1.89 x 3.74 x 2.44" (48 x 95 x 62 mm)

Cutout area 1.77 x 3.62" ±.02 (45 x 92mm ±.5)**Space behind panel** 3.15" (80mm) minimum space required behind panel (includes space for connectors/wiring)**Weight** 6.87oz (195g)

1.2 - Display

Digits 4 digit red LED, 0.8" (20mm), 7-segment characters

Display range -1999 to 9999

Annunciators 2x setpoint indicator LEDs (R2A model only)

IP65 sealed front bezel



1.3 - Case dimensions

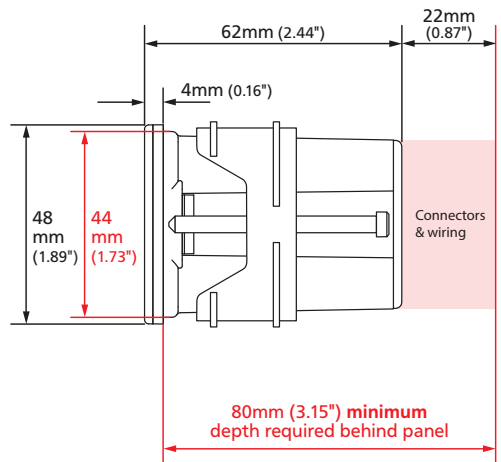
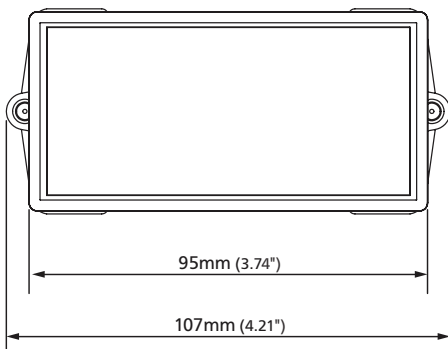
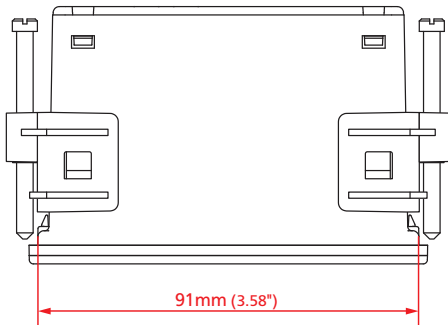

2

HARDWARE INSTALLATION

2.1 - Installation instructions

The Merlin is designed to be mounted into an enclosed panel, and meets IP65 requirements when properly installed.

- A Prepare the **Panel Cutout** to 92x45mm ± 0.5 (3.62x1.77" ± 0.02) as shown below.
- B Remove the **Mounting Clips** from the Merlin unit.
- C Slide the **Panel Gasket** over the rear of the unit to the back of the **Bezel**.

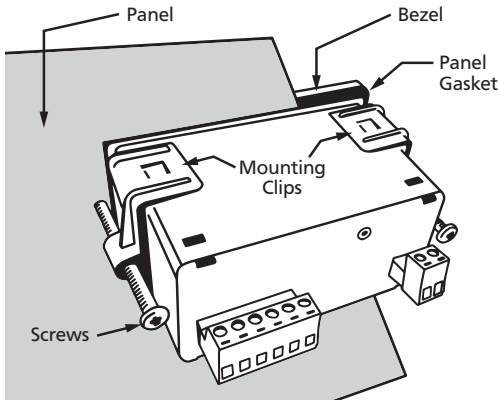

- D From the front of the panel, insert the Merlin into the **Panel Cutout**. Holding the unit in place, engage the **Mounting Clips** so that the tabs snap into place over the notches on the case.
- E To achieve a proper seal, tighten the **Screws** evenly until the unit sits firmly against the panel (torque to approximately 70N-cm [6.2 in-lbs]). Do not over-tighten the screws.

Panel Cutout

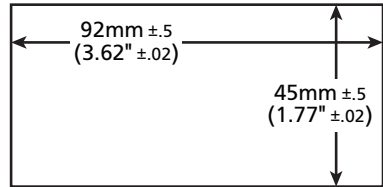

2.2 - Installation environment

The Merlin should be installed in a location that does not exceed the maximum operating temperature, and at a safe distance from other devices that generate excessive heat. The installation environment should provide good air circulation to the unit.

The bezel, plastic casing and product label may be cleaned, if required, using a soft, damp cloth and neutral soap product.

Continuous exposure to direct sunlight should be avoided, as this may accelerate the aging process of the bezel.

3 SOFTWARE INSTALLATION

ToolBox offers a smart, no-fuss setup experience for your Merlin universal indicator. It features USB powered programming (no power supply required!) and has been designed to simplify and speed up configuration.

You must install ToolBox before connecting the Merlin to your computer. If you have already connected the meter using the Bridge Key, please disconnect it before continuing.

- A** Download the latest version of ToolBox from **www.defineinstruments.com/toolbox**



For ease of access, we recommend saving the install file on your desktop. If you can't find the install file, check whether your browser has saved it in your 'Downloads' folder.

- B** Extract the install file from the zip folder. Right-click on the zip folder and choose 'Extract All', (or extract the file using another extraction utility of your choice).

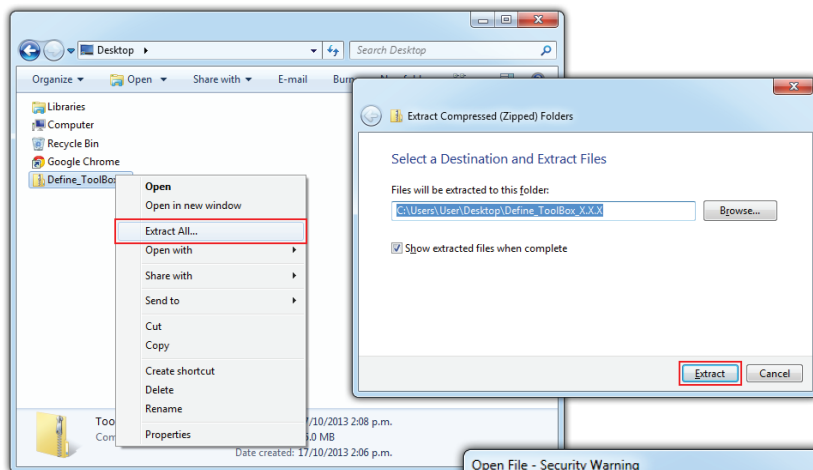

Fig 1

- C** Double-click on the extracted .msi install file. This will launch the ToolBox installer.

Depending on your security settings, a 'Security Warning' dialog may appear. If you see the security message, click 'Run'.

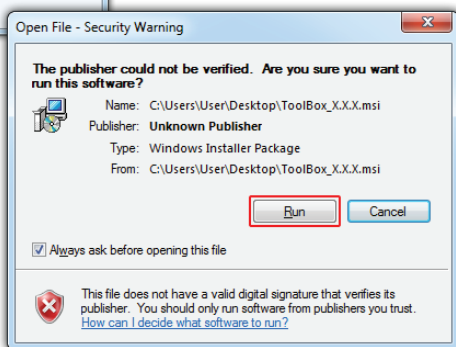

Fig 2

D The ToolBox setup wizard will launch (Fig 3).

Click **'Next'** to get started.

E The wizard will also ask for confirmation that you wish to begin the installation.

Click **'Next'** to continue.

F Next the wizard will prompt you to select an installation folder (Fig 4). You may accept the default installation folder, or select an alternative location by clicking **'Browse'**.

Click **'Next'** to continue.

G The install wizard will now install ToolBox, and a progress bar will appear. Please wait. This process usually takes 2-3 minutes.

If you are using Windows with 'User Account Control' enabled, you may be asked for permission to continue the installation (Fig 5). Click **'Yes'**.

(Note that this dialogue may cause a slight delay to the installation process.)

H When ToolBox has finished installing, 'Installation Complete' will appear (Fig 6). Click **'Close'**.

The installer will place an icon on your desktop for easy access to ToolBox.

The downloaded **.zip** and **.msi** installer files are no longer needed, and may be deleted.



Fig 3

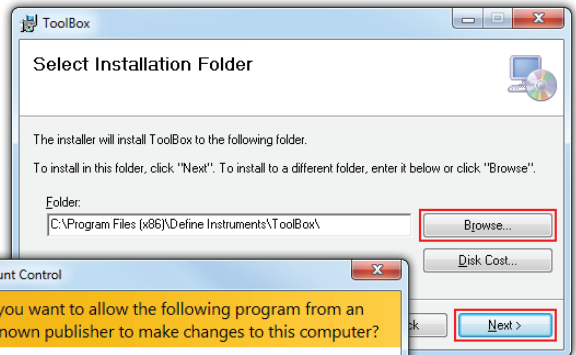

Fig 4

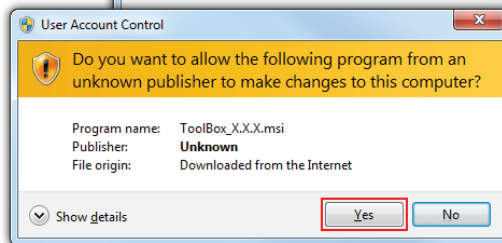

Fig 5

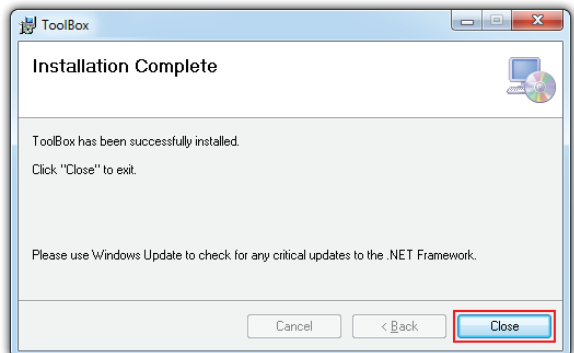

Fig 6

4

SOFTWARE CONFIGURATION USING TOOLBOX

4.1 - Bridge Key

Install the ToolBox software (see Section 3) before connecting the Merlin to your PC.

Then connect the Merlin to your computer's USB port using the Bridge Key (supplied separately), as shown below. The interface cable connects to the USB programming jack on the unit's back panel (see 5.3D). A USB extension cable is supplied for your use if required - this is often used for convenience in accessing USB ports located at the back of the computer.

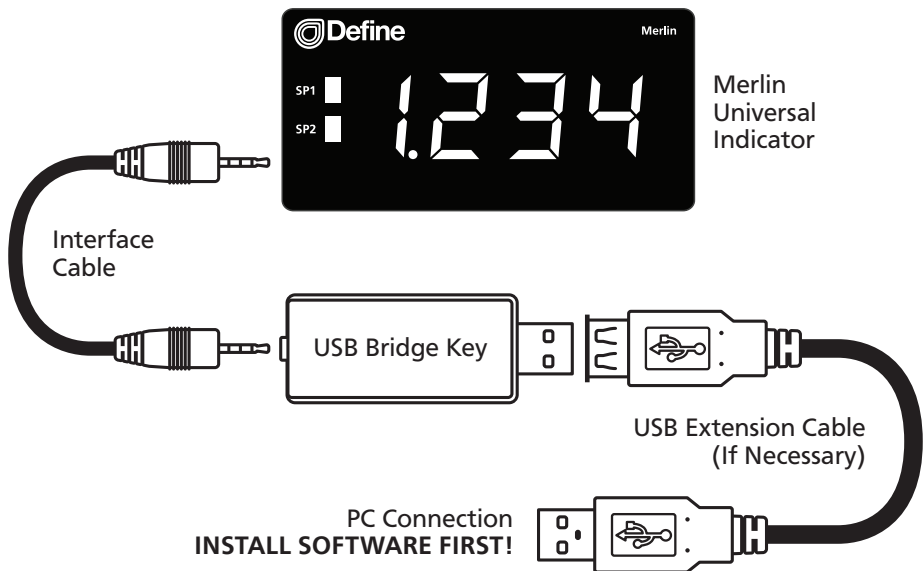
**CAUTION****Risk of damage to equipment or PC**

Ensure that all connections between the Bridge Key and your Merlin are secure. Connecting your indicator with cables that are not firmly 'pushed in' will result in connection faults, and in extreme cases could cause damage to your computer.

Do not unplug the Bridge Key or any connecting cables while ToolBox is busy applying changes to the Merlin. This may cause loss of settings, or unexpected unit behaviour.

**CAUTION****Not UL approved**

The Bridge Key is sold separately to the Merlin and has not been certified for UL.

Merlin universal indicator. To set up your indicator, **only the Bridge Key is required - you do not need to supply power.**

ToolBox features a **comprehensive help panel** that will guide you through the setup of your Merlin universal indicator. Helpful hints and explanations will appear when you adjust a setting using the ToolBox controls.

There are three main navigation pages/tabs:

- › **Input/Output:** Input mode/range, Scaling/offset, Display, Retransmission scaling
- › **Setpoints:** Alarm control/mode, Setpoint activation points, advanced modes
- › **Advanced:** Load/save configuration, Create configuration certificate

A Double-click the ToolBox icon on your desktop to launch the ToolBox program.

B With the Merlin connected to your computer's USB port (see 4.1), click the green '**Connect**' button. This will scan your computer's Com ports and automatically connect to your device.

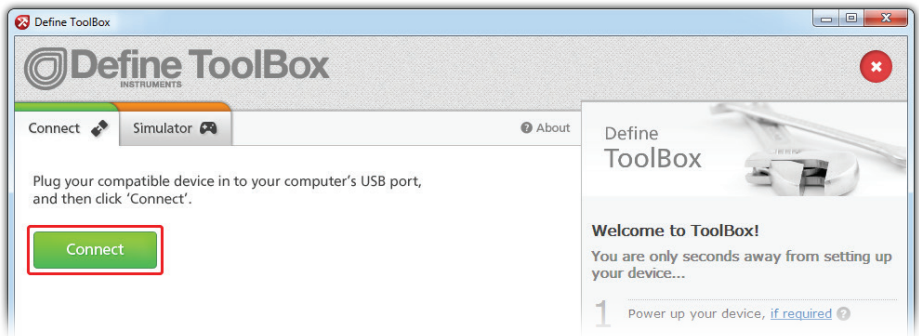

Connection problems?

ToolBox will auto-detect and connect to the Merlin when you click the '**Connect**' button. If you have problems establishing a connection, please check the following:

- › Ensure that all connections between the device and your computer are secure. The main interface cable must be fully inserted into both the USB programmer and the Merlin's programming port. Press firmly.
- › Try disconnecting and reconnecting the Merlin USB, or using a different USB port on your computer.
- › Disconnect any additional compatible devices. The software auto-detect feature does not work if multiple Merlins are connected simultaneously.

4.3 - ToolBox interface overview

Main Navigation Tabs

Input/Output, Setpoints, and Advanced configuration pages. (ToolBox will detect your meter outputs and will only display relevant tabs.)

Control Area

Main control area for configuring your meter. Any changes made in this area will bring up the **Apply Bar** (see below)

Connection Panel

Disconnect button
Connection status
Live display

The screenshot displays the ToolBox interface with the following elements:

- Main Navigation Tabs:** Input/Output (selected), Setpoints, Advanced, and About.
- Control Area:**
 - Input:** Input Mode (VDC), Input Range ($\pm 200\text{mV DC}$), Offset Adjust (0.0), Filter Time (0 seconds).
 - Scaling/Offset:** Mode (mV (-200.0 to 200.0)).
 - Display:** Brightness slider.
 - Output (Retransmission):** Display Value Of 0.0 = 4.000 mA Output; Display Value Of 1000.0 = 20.000 mA Output.
- Apply Bar:** A pink bar at the bottom left with the text "Your configuration has unapplied changes" and an "Apply" button.
- Connection Panel:** Shows "Connected COM 3" with a green checkmark, a "Disconnect?" button, and a live display showing "1234".
- Input Mode & Type/Range:** A diagram showing terminal connections for SETPOINTS (SP 1, SP 2), USER INPUT (UT 1, COM), ANALOG OUTPUT (4-20mA), and a power source (POWER 24-250V AC, 19.5-250V DC).
- Help Panel:** A yellow panel at the bottom right containing text about $\pm 200\text{mV DC}$ support and Offset Adjust.

Apply Bar

Appears if you have made any changes in the **Control Area**. ToolBox will not allow you to browse to a new tab in the **Main Navigation** with unapplied changes to your configuration.

Help Panel

Diagrams, explanations, and helpful tips will automatically appear in this panel as you configure your meter.

5

WIRING

5.1 - Wiring overview

Electrical connections are made via plug in terminal blocks at the rear of the meter. All conductors must conform to the meter's voltage and current ratings, and be suitably rated for the expected temperature range to be incurred.

When wiring the meter, check all connections by comparing the terminal numbers shown on the meter label against the appropriate wiring diagrams in this manual (5.3–5.8 and Section 6), or in the Define ToolBox software. Strip the wire, leaving around 0.25" (6mm) of bare lead exposed. If you are using stranded wire, this should

be tinned with solder. Insert the lead into the correct plug in the correct position, and tighten until the wire is secure. Verify tightness by pulling on the wire.

Follow all local codes and regulations when wiring and installing the meter. Each terminal is rated to accept one wire from #14 AWG (2.5mm) to #20 AWG. However it is also possible to accept two #18 AWG wires, or up to four #20 AWG wires.



CAUTION

All field wiring must rated at a minimum of 158°F (70°C).

5.2 - EMC installation guidelines

The Merlin has been designed to cope with large EMC disturbances. This has been achieved by continual testing and improvement of filtering and layout techniques over many years.

The Merlin not only meets CE noise requirements, but surpasses them in many tests. (For full details and test results, please see Appendix A.)

However in some applications with less than optimum installations and large power switching, the EMC performance of the Merlin can be further improved, by:

- A Installing the Merlin in an earthed metal enclosure. This is particularly useful if the control box is mounted close to large power switching devices like contactors. Every switching cycle there is a possibility of generating a large amount
- B Using shielded cable on sensitive input and control signal lines. Good results can be obtained by grounding the shields to the metal enclosure close to the entry point. All cables act as aerials and pick up unwanted R.F. radiated signals and

of near field radiated noise. The metal enclosure acting as a faraday cage will shunt this radiation to ground and away from the Merlin. Further improvements can be made with this type of noise by increasing the physical distance from the power devices. For example, increasing the control box distance from 6" to 12" from the noise source will reduce the noise seen by the control box by a factor of 4. Probably the cheapest and best results in this situation could be obtained by adding RC snubbers to the contactors or power switches.

noise; the earthed shield acts as a faraday cage around the cables, shunting the unwanted energy to ground. Shields can also help with capacitively coupled noise typically found in circumstances when signal cable is laid on top of noisy switching power cables. Of course in this case you are better off to keep separate signal and power lines.

C Laying cable on earthed cable trays can also help reduce noise seen by the

meter. This is particularly useful if there are long cable runs, or the unit is close to radiating sources such as two way radios.

D The relay outputs of the Merlin have built in MOVs to help reduce EMI when switching inductive loads. EMI can further be reduced at the load by adding snubbers for AC signals or a flyback diode for DC coils.

5.3 - Back panel

The back panel of the Merlin may have up to 5 screw terminals (A–F) and 1 USB programming jack (D). Ports C–F are installed on the R2A model only.

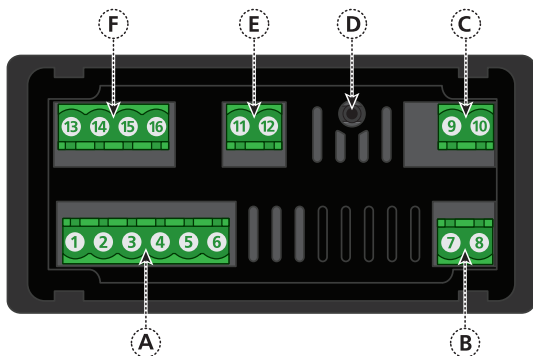

A Sensor input
(Pins 1–6, Section 6)

B Power supply
(Pins 7–8, See 5.4)

C Analog output
(Pins 9–10, See 5.6)

D USB programming jack
(See Section 4)

E User input
(Pins 11–12, See 5.8)

F Relay outputs
(Pins 13–16, See 5.7)

5.4 - Power supply

See 5.3B, pins 7–8

The Merlin features a wide range **Power Supply** that suits both AC mains and 24V DC applications. The Merlin uses a full bridge rectifier, so it is **not sensitive to polarity** for DC power inputs.



CAUTION

Risk of electric shock.

AC power supplied to the meter must be protected by a UL approved 10A circuit breaker. DC power supplied to the meter must be protected by a UL approved 1A, 250V fuse.

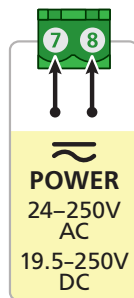

5.5 - Sensor input

See 5.3A, pins 1–6

The **Sensor Input** terminal can be wired to suit numerous input types. See Section 6 for input wiring, or refer to the ToolBox help panel as you are configuring the unit.

5.6 - Analog output (If installed)

See 5.3C, pins 9–10

If your model includes **Analog Output**, wire it as shown (right).

The analog output can be scaled to suit your application using the ToolBox software.

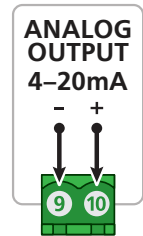

5.7 - Relay outputs (If installed)

See 5.3F, pins 13–16

If your model includes **Relay Outputs**, wire them as shown (right). The setpoints can be configured using ToolBox for a variety of alarm or control functions.

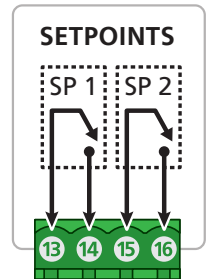

5.8 - User input (If installed)

See 5.3E, pins 11–12

If your model includes **Relay Outputs**, then a **User Input** is also provided. This can be connected to a switch as shown, to perform manual relay reset, latching or zero functions. These options are fully configurable using the ToolBox software.

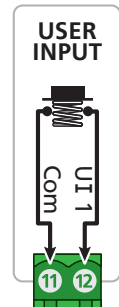

CAUTION

The **User Input common** is **NOT** isolated from the **Sensor Input**. In order to preserve the safety of the meter application, the User Input common must be suitably isolated from hazardous live earth referenced voltages; or the User Input common must be at protective earth ground potential.

If not, hazardous live voltage may be present on the User Input and the User Input common terminals. Appropriate considerations must then be given to the potential of the User Input common with respect to earth common.

6

INPUT TYPES

**CAUTION**

Risk of electric shock. Dangerous and lethal voltages may be present on the terminals of the meter. Please take appropriate precautions to ensure safety.

**CAUTION**

Risk of danger. The sensor input can potentially float to dangerous and unexpected voltages depending on what external circuit it is connected to. Appropriate considerations must be given to the potential of the sensor input with respect to earth common.

6.1 - Thermocouple input

Thermocouple types

B, E, J, K, N, R, S, T

Input impedance 1M Ω min

TC lead resistance 100 Ω max

Cold junction comp. -10 to 70°C

Accuracy E, J, K, N, T: $< \pm 1^\circ\text{C}$.

B, R, S: $< \pm 2^\circ\text{C}$.

Temperature drift

E, J, K, N, T: $< \pm 0.05^\circ\text{C/C}$.

B, R, S: $< \pm 0.2^\circ\text{C/C}$.

Sensor break output drive

Function high upscale/low downscale

CJC error $< \pm 1^\circ\text{C}$

Response time 400msec

Temperature (thermocouple)

The thermocouple is one of the most common temperature sensors used in industry. It relies on the Seebeck coefficient between dissimilar metals.

The thermocouple type is selected with reference to the application temperature range and environment. The most common thermocouple types for general purpose applications are J and K type.

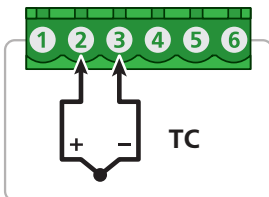

Supported thermocouple types/ranges

K	-200°C (-328°F)	1372°C (2502°F)
B	400°C (752°F)	1800°C (3272°F)
E	-200°C (-328°F)	800°C (1472°F)
J	-200°C (-328°F)	1000°C (1832°F)
R	-50°C (-58°F)	1760°C (3200°F)
S	-50°C (-58°F)	1760°C (3200°F)
T	-200°C (-328°F)	400°C (752°F)
N	-200°C (-328°F)	1300°C (2372°F)

6.2 - RTD input

RTD input Pt100 or Pt1000 DIN 3-wire type (2-wire can be used with offset trim)

Pt100 lead wire resistance 50Ω/wire max. 0.02% FSO offset error per Ω of lead resistance mismatch

Pt1000 lead wire resistance 20Ω/wire max. 0.002% FSO offset error per Ω of lead resistance mismatch

Sensor current 0.3mA nominal

Sensor break output drive
Function high upscale/low downscale

Accuracy Better than 0.2°C

Temperature drift <0.007°C/C

Response time 400msec

Temperature (RTD)

The RTD (standing for Resistance Temperature Device) is highly stable and accurate, and is fast becoming the most popular temperature sensor in industry.

Often referred to as Pt100 and Pt1000, the Pt represents platinum (the dominant metal in its construction), and 100/ 1000 is the resistance in ohms at 0°C.

Supported RTD types/ranges

Pt100	-200°C (-328°F)	320°C (608°F)
Pt1000	-200°C (-328°F)	320°C (608°F)

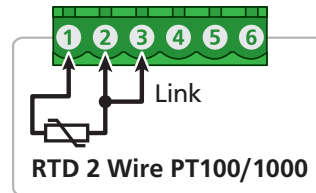
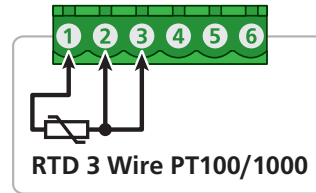

6.3 - NTC input

NTC -50 to 125°C (various thermistors)

Sensor types 10K Beta 3984/3435

Response time 100msec

Accuracy Better than 0.4°C

Temperature drift <50ppm/°C

Temperature (NTC)

NTC (Negative Temperature Coefficient), is a particular type of thermistor.

NTC's are popular in the HVAC industry due to their low cost, but have a limited temperature range which makes them less popular in general industry.

The biggest issue with their general acceptance is that there is no standard that covers inter operability between different thermistor manufacturers.

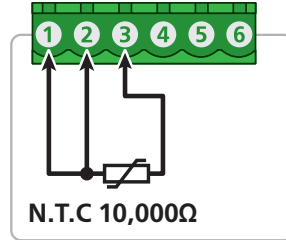

Supported NTC types/ranges

10K Beta 3984	-55°C (-67°F)	125°C (257°F)
10K Beta 3435	-50°C (-58°F)	110°C (230°F)

6.4 - Current input

Range 0/4–20.000mA

Excitation +22V DC, 25mA max

USB prog zero 0–±99% of span

Field prog span 1μA–24mA DC

Input resistance 10Ω

Max over-range 50mA DC continuous

Linearity and repeatability
<±0.02% FSO typical

Temperature drift <50ppm/°C

Response time 100msec

0/4–20mA DC

0/4–20mA DC is the most commonly used analog signal in industry, and is universally accepted. As a current loop, it is unaffected by voltage drops in cables, and can be transmitted over long distances without signal degradation.

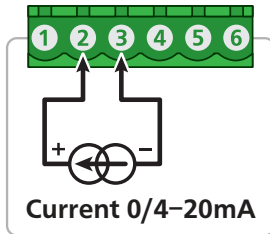

4–20mA DC, loop powered transmitter

The meter can provide power to a loop powered transmitter, and at the same time measure the signal. This configuration is ideal for when there is a long distance between the sensor and the meter.

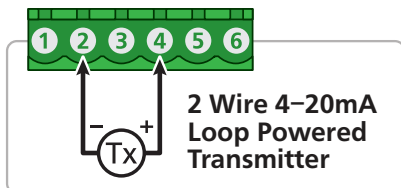

0/4–20mA DC, 3 or 4 wire transmitter

The meter can provide up to 25mA to power an external 3 or 4 wire transmitter, and at the same time measure the signal.

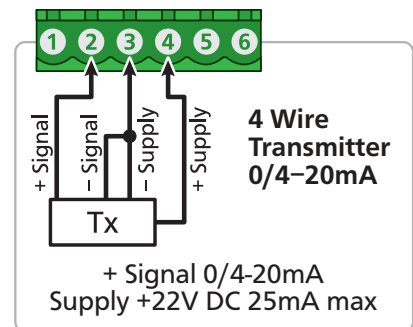
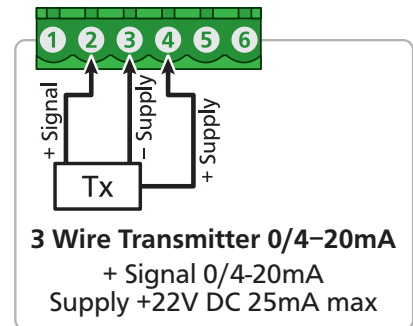

6.5 - Voltage input

Ranges $\pm 200\text{mV}$, -200mV to 1V , $0-10\text{V}$, $\pm 10\text{V}$, -10 to 30V , $0-300\text{V}$

USB prog zero $0-\pm 99\%$ of span

USB prog span 95% of FSO

Input resistance $1\text{M}\Omega$ min

Linearity and repeatability

$< \pm 0.02\%$ FSO typical

($0-10\text{V} = < \pm 0.05\%$; $0-300\text{V} = < \pm 0.1\%$)

Temperature drift $< 50\text{ppm}/^\circ\text{C}$

Response time 100msec

$\pm 200\text{mV}$ DC

For low signal applications the meter supports a $\pm 200\text{mV}$ DC range. Typical applications include measuring large DC currents using external current shunts.

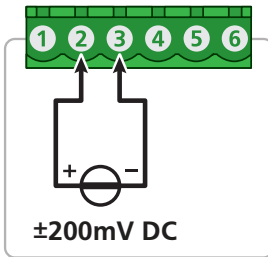

-200mV to 1V DC

A -200mV to 1V range is provided for interfacing to sensors and other electronic apparatus that provide this output.

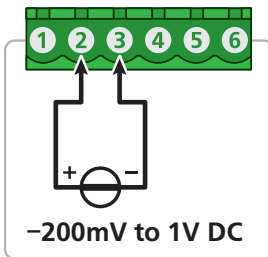

$0-10\text{V}$ DC

$0-10\text{V}$ DC is a common process signal generated by transmitters, meters and PLCs.

It would normally be scaled into engineering units by the meter.

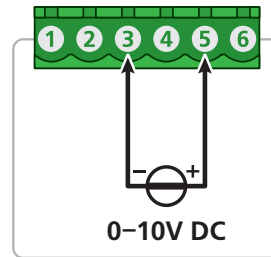

$\pm 10\text{V}$ DC

$\pm 10\text{V}$ DC is a common process signal generated by transmitters, meters and PLCs. It would normally be scaled into engineering units by the meter.

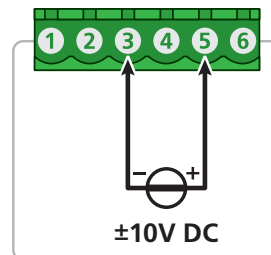

-10 to 30V DC

This is a general purpose voltage measuring range, typically used to measure battery voltages, power supply outputs etc.

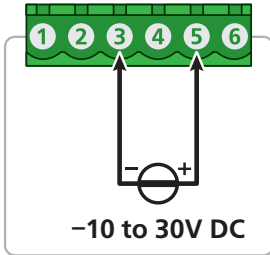

0–300V DC

This higher voltage general purpose range is typically used to measure battery voltages, power supply outputs, etc.

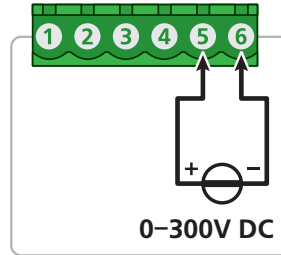
**CAUTION**

Risk of electric shock

Exercise extreme caution when handling high voltage inputs.

**CAUTION**

Rated voltage between pins 5 & 6 and earth is 300V DC max.

6.6 - Digital pulse

Frequency range 0–2000.0Hz

Sensors Open collector NPN (2 and 3 wire)/PNP (2 wire only)

Excitation +22V DC, 25mA max

Response time 100msec

Software modes General frequency, Flow rate (pulse), or RPM (pulse)

Linearity and repeatability 0.05%

Temperature drift <50ppm/°C

General frequency mode

General Frequency mode allows an NPN or PNP input (up to 2KHz) to be measured and scaled to any engineering unit.

The meter can also provide up to 25mA to power an external device.

Flow rate mode

Flow Rate mode enables an input from an NPN or PNP paddle type flow meter to be converted to a flow rate. The input signal (up to 2KHz) is converted into a flow rate by programming the unit with the sensor manufacturer's K-factor value.

The meter can also provide up to 25mA to power a 3 wire NPN paddle type flow sensor.

RPM mode

ToolBox RPM mode enables an input from an NPN or PNP proximity sensor to be converted to an RPM (Revs Per Minute) value. The input signal (up to 2KHz) is converted into RPM by programming the unit with the pulses per revolution value.

The meter can also provide up to 25mA to power a 3 wire NPN proximity sensor.

NPN open collector output

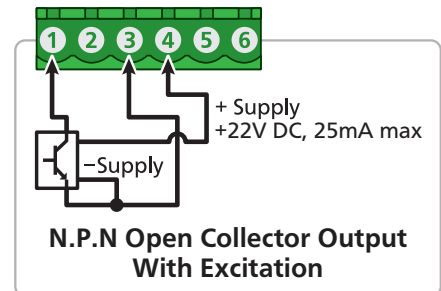
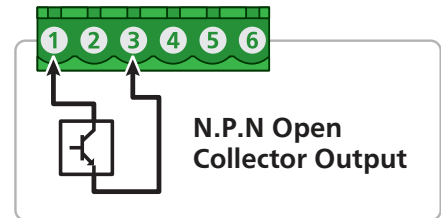

PNP open collector output

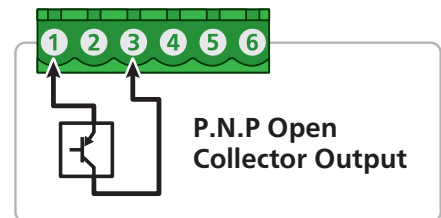

⚠ NB: DOES NOT SUPPORT PNP 3 WIRE!

6.7 - Potentiometer input

Potentiometer input 3-wire

Excitation voltage Variable

Potentiometer resistance <1k Ω low pot;
1–4k Ω med pot; 4–20k Ω high pot

Field prog zero 0–90% of span

Field prog span 0.1–100%

Linearity and repeatability
< \pm 0.05% FSO typical

Response time 100msec

Temperature drift <50ppm/ $^{\circ}$ C

3 wire potentiometer

A 3 wire potentiometer is typically used to measure position. The low, medium or high potentiometer range can be programmed to your unit using the ToolBox software.

These ranges must be calibrated using the two point calibration method.

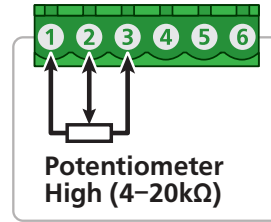
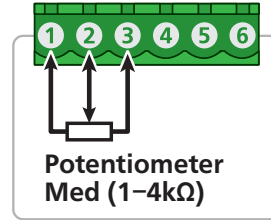
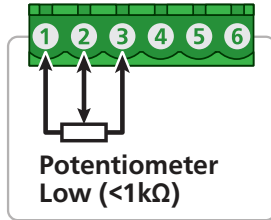

6.8 - AC current sensor

Sensor type Current transformer (Define Instruments ACCS-420/010)

Amperage range Header selectable 100/150/200A; Overload 175/300/400A respectively (continuous)

Output (Representing 0–100% of full scale input range)

ACCS-420 = 4–20mA DC loop powered

ACCS-010 = 0–10V DC

Power supply

ACCS-420 = Loop powered, 15–36V DC

ACCS-010 = Self powered

Accuracy 1% of full scale

Response time 250ms (10–90%)

Isolation voltage 2,000V

Frequency 50–60Hz

AC current sensors

The meter accepts input from a Define Instruments AC current sensor. Set the jumper on the top of the current sensor to the desired current range, as shown (right).

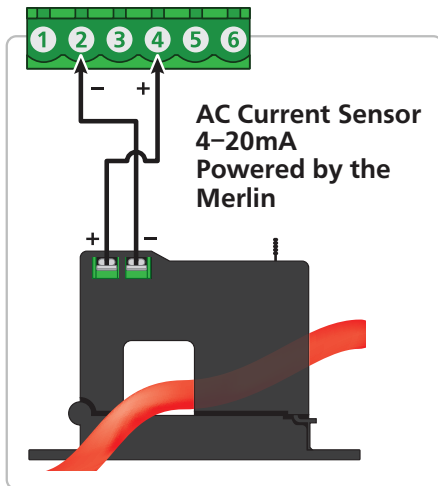

Jump Range

0–100A

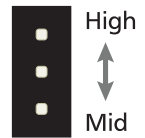

0–150A

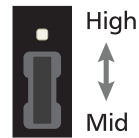

0–200A

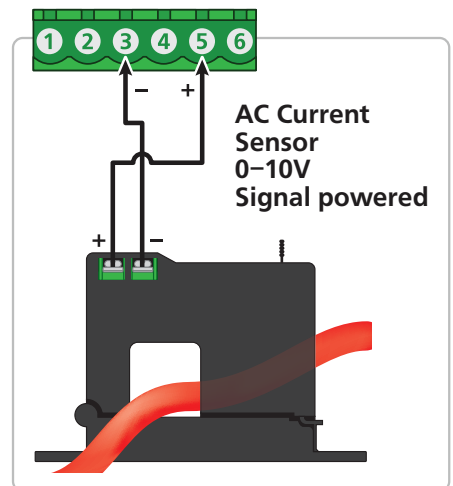
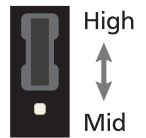

7.1 - Calibration

The meter has been fully calibrated at the factory, and can be recalibrated in software using Define ToolBox (see Section 4). Scaling to convert the input signal to a desired display value is also done using ToolBox.

If the meter appears to be indicating incorrectly or inaccurately, refer to troubleshooting before attempting to calibrate the meter. When recalibration is required (generally every 2 years), it should only be performed by qualified technicians using appropriate equipment.

Calibration does not change any user programmed parameters. However, it may affect the accuracy of the input signal values previously stored.

7.2 - Troubleshooting

Problem	Resolution
No display	Check power connections.
CErr	Internal Comms Error Try re-starting unit. If the problem is intermittent, this error could be caused by an EMC issue. Please refer to 5.2 for potential remedies.
ErCL	Analog Output Calibration Error Factory calibration of analog output is corrupt or missing. Return unit to factory for re-calibration.
ErFL	Display Flash Error Settings such as decimal point, scaling, and brightness will be lost. Reconnect to Define ToolBox (see Section 4) and set up the meter again.
Er01 to 10	Analog Input Error Error type indicated by a numerical error code (01–10). Please return to factory for repair.
SErS	Sensor Error Sensor is missing or faulty. Check your sensor wiring.
oVer	A/D Overflow Check your sensor wiring. If the sensor wiring is correct, check the signal level.
undr	A/D Underflow Check your sensor wiring. If the sensor wiring is correct, check the signal level.

For further assistance, please contact technical support using the contact details listed at the end of this document.

7.3 - Service

Please return this product to the manufacturer if servicing is required.

THE MERLIN HAS NO USER SERVICEABLE PARTS.

For further assistance, please contact technical support using the contact details listed at the end of this document.

A

APPENDIX A - EMC TEST RESULTS

The Merlin has been designed to cope with large EMC disturbances. This has been achieved by constantly testing and improving filtering and layout techniques over many years. The Merlin offers superior R.F. filtering on all inputs, outputs and power supplies, when compared to most competing products.

The Merlin not only meets CE noise requirements, but surpasses them in many tests. Furthermore, all testing was performed in plastic enclosures without shielded cabling.

Immunity - Enclosure Ports

Phenomenon	Basic Standard	Test Value	Performance Criteria
EM Field	IEC 61000-4-3	10Vm (80Mhz to 1GHz) 3V/m (1.4GHz to 2.7GHz)	Meets Criterion A
Electrostatic Discharge (ESD)	IEC 61000-4-2	4KV/8KV contact/air	Meets Criterion A (Note 1) Meets NAMUR NE 21 recommendation

Immunity - Signal Ports

Phenomenon	Basic Standard	Test Value	Performance Criteria
Conducted RF	IEC 61000-4-6	3V(150Khz to 80Mhz)	Meets Criterion A
Burst	IEC 61000-4-4	1KV (5/50ns,5Khz) 1KV(5/50ns,100Khz)	Meets Criterion A (Note 1) Meets NAMUR NE 21 recommendation
Surge	IEC 61000-4-5	1KV L-E	Meets Criterion A (Note 1)

Immunity - AC power

Phenomenon	Basic Standard	Test Value	Performance Criteria
Conducted RF	IEC 61000-4-6	3V (150Khz to 80Mhz)	Meets Criterion A
Burst	IEC 61000-4-4	2KV (5/50ns, 5Khz) L-N 1KV (5/50ns, 5Khz) L-L	Meets Criterion A (Note 1) Meets Criterion A (Note 1)
Surge	IEC 61000-4-5	2KV L-E 1KV L-L	Meets Criterion A (Note 1) Meets Criterion A (Note 1)

Voltage Dips	IEC 61000-4-11	0% during 1 cycle	Meets Criterion A (Note 1)
		40% during 10/12 cycles	Meets Criterion A (Note 1)
		70% during 25/30 cycles	Meets Criterion A (Note 1)

Note 1: Where indicated by Note 1, EN61326-1 calls for a Criterion B pass; unit exceeds this by meeting Criterion A.

Performance Criteria

Performance Criterion A

During testing, normal performance within the specification limits.

Performance Criterion B

During testing, temporary degradation, or loss of performance or function which is self-recovering.

Note: Stated performance by the manufacturer will have an additional error of less than 0.2% of full scale range due to EMC influence.

B**APPENDIX B - WARRANTY & USER'S RESPONSIBILITY**

Warranty

Define Instruments warrants that its products are free from defects in material and workmanship under normal use and service for a period of one year from date of shipment.

Define Instruments's obligations under this warranty are limited to replacement or repair, at its option, at its factory, of any of the products which shall, within the applicable period after shipment, be returned to Define Instruments's facility, transportation charges pre-paid, and which are, after examination, disclosed to the satisfaction of Define Instruments to be thus defective.

The warranty shall not apply to any equipment which shall have been repaired or altered, except by Define Instruments, or which shall have been subjected to misuse, negligence or accident.

In no case shall Define Instruments's liability exceed the original purchase price. The aforementioned provisions do not extend the original warranty period of any product which has been either repaired or replaced by Define Instruments.

User's Responsibility

We are pleased to offer suggestions on the use of our various products, by way of printed matter, on our website, or through direct contact with our sales/application engineering staff.

However, since we have no control over the use of our products once they are shipped, **NO WARRANTY, WHETHER OF MERCHANTABILITY, FITNESS FOR PURPOSE OR OTHERWISE** is made beyond repair, replacement, or refund of purchase price at the sole discretion of Define Instruments.

Users shall determine the suitability of the product for the intended application before using, and the users assume all risk and liability whatsoever in connection therewith, regardless of any of our suggestions or statements as to application or construction.

In no event shall Define Instruments's liability, in law or otherwise, be in excess of the purchase price of the product.

Define Instruments cannot assume responsibility for any circuitry described. No circuit patent or software licenses are implied. Define Instruments reserves the right to change circuitry, operating software, specifications, and prices without notice at any time.



Define Instruments

New Zealand (Head Office)

 10B Vega Place, Rosedale,
Auckland 0632, New Zealand
PO Box 245 Westpark Village,
Auckland 0661, New Zealand

Ph: +64 (9) 835 1550

Fax: +64 (9) 835 1250

 sales@defineinstruments.co.nz

www.defineinstruments.co.nz

United States (Dallas, TX)

Ph: (214) 926 4950

 sales@defineinstruments.com

www.defineinstruments.com

South Africa (Pretoria)

 sales@defineinstruments.co.za

www.defineinstruments.co.za