

CalibratorUnit

Models CPU6000-W, CPU6000-S, CPU6000-M

WIKA data sheet CT 35.02

Applications

- Determination of the required mass loads or the reference pressure for calibration with pressure balances
- Recording of data, relevant for certificates
- Calibration of relative pressure measuring instruments with absolute pressure references and vice versa
- Easy calibration of pressure transmitters through the voltage supply and multimeter function

Special features

- Patent applied for, among others DE Patent No. 102013215351
- New calibration concept simplifies certificate generation
- Easy operation and set-up
- Acquisition and automatic correction of all critical influencing factors, to increase the accuracy of the measurement
- Can also be used with other calibration instruments and WIKA-CAL software

Description

General information

The CPU6000 series is made up of three instruments: the model CPU6000-W weather station, the model CPU6000-S pressure balance sensor box and the model CPU6000-M digital multimeter. All of these products serve for the acquisition of measured value data, relevant for calibration certificates.

The new calibration concept simplifies the generation of certificates and increases the productivity and quality of the certificate generation process.

Features

In combination with any pressure balance, the CPB-CAL (iPad® app) and/or WIKA-CAL (PC software) can determine the necessary mass loads or the reference pressure. Through simple operation and setting, the calculation of the mass loads or the pressure is made easier. The CalibratorUnit takes into account all critical influencing factors and thus increases the accuracy of the measurement.



CPU6000 series and iPad®-App CPB-CAL

A calibration of relative pressure measuring instruments with absolute pressure references, and vice versa, is also possible.

Via the integrated voltage supply and multimeter function, easy calibrations of pressure transmitters can be carried out. The weather station and the digital multimeter can also be used, independently of the pressure balance calibration, with other calibration instruments and the WIKA-CAL software. Existing automatic calibration systems can thus be enhanced.

Software and generation of certificates

The generation of the certificate is made in conjunction with the WIKA-CAL software. The CalibratorUnit communicates wirelessly over Bluetooth® 4.0 with an iPad®. A USB interface is available for PC connection.

iPad® is a registered trademark of Apple Inc. in the United States and other countries.

Series CPU6000

Weather station, model CPU6000-W

The CPU6000-W provides measured values such as atmospheric air pressure, relative humidity and the ambient temperature of the laboratory environment.

The WIKA-CAL software automatically documents, in the respective test report, the measured values and saves these to a database. Furthermore, with this software or the CPB-CAL iPad® application, the measured values are used in conjunction with the pressure balance for the calculation of the mass loads.

Pressure balance sensor box, model CPU6000-S

The CPU6000-S measures the piston temperature and displays the floating position of the masses. The sensor is fitted directly to the pressure balance and serves to achieve the highest accuracy with a single pressure balance.

Digital multimeter, model CPU6000-M

The CPU6000-M fulfills the function of a digital multimeter and power supply unit when electronic pressure transmitters must be calibrated. The CPU6000-M supplies test items with DC 24 V and measures voltage and current signals. In addition, digital pressure sensors such as the model CPT61X0 and model D-10 can be connected directly over the RS-232 interface.



CPB-CAL iPad® app

The iPad® application calculates the mass loads for pressure balances or the reference pressure while taking the measured parameters from the CPU6000 into account. The conversion can be carried out in all common pressure units. As an additional parameter, the local value of gravity can be specified for location-independent measurements. The application can be used 'on the fly' and is very user-friendly.

Specifications Series CPU6000



Weather station, model CPU6000-W



Symbol	Description	Measuring range	Accuracy
	Ambient temperature	-40 ... +123.8 °C	±0.5 °C ¹⁾
	Relative humidity	0 ... 100 % r. h.	±5.0 % r. h. ²⁾
	Atmospheric pressure	550 ... 1,150 mbar abs. (opt. 551 ... 1,172 mbar abs.)	0.05 % FS (opt. 0.01 % of reading)

1) The calibration is performed for the points 18 °C, 23 °C and 25 °C following a warm-up time of 120 minutes.

2) The calibration is performed for the points 30 % r. h., 50 % r. h. and 80 % r. h. following a warm-up time of 120 minutes.



Pressure balance sensor box, model CPU6000-S

Symbol	Description	Measuring range	Accuracy
	Piston temperature	-50 ... +250 °C	±0.1 °C at 20 °C
	Floating position of the masses	4 ... 20 mA 20 ... 200 mm	±0.5 mm

Note:

It is recommended to install the sensor box for pressure balances of the CPB5000, CPB5000HP and CPB5800 series.

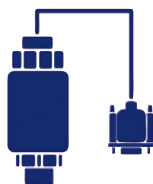

Digital multimeter, model CPU6000-M

Symbol	Description	
	Current input	Measuring range 0 ... 20 mA Accuracy $\pm 1.6 \mu\text{A}$
	Voltage input	Measuring range 0 ... 10 V Accuracy $\pm 0.5 \text{ mV}$
	Voltage supply	DC 24 V (load: max. 50 mA; min. 20 mA)
	Interface	Model D-10 Models CPT6100 and CPT6180 RS-232 interface, 9600 Baud, 8N1

Base instrument	Model CPU6000-W	Model CPU6000-S	Model CPU6000-M
Voltage supply			
Power supply	DC 24 V, 625 mA		
Permissible ambient conditions			
Operating temperature	15 ... 45 °C		
Storage temperature	0 ... 70 °C		
Communication			
Interface	USB with PC, Bluetooth® 4.0 with iPad® 3.0 or higher		
Case			
Dimensions (W x H x D)	190.4 x 58 x 110 mm	190.4 x 58 x 80 mm	190.4 x 58 x 110 mm
Weight	1.44 kg	1.18 kg	1.29 kg

Certificates

Calibration	Standard: factory calibration certificate Option: DKD/DAkkS calibration certificate
Recommended calibration interval	1 year (depending on the conditions of usage)

Approvals and certificates, see website

Dimensions in mm

Weather station, model CPU6000-W

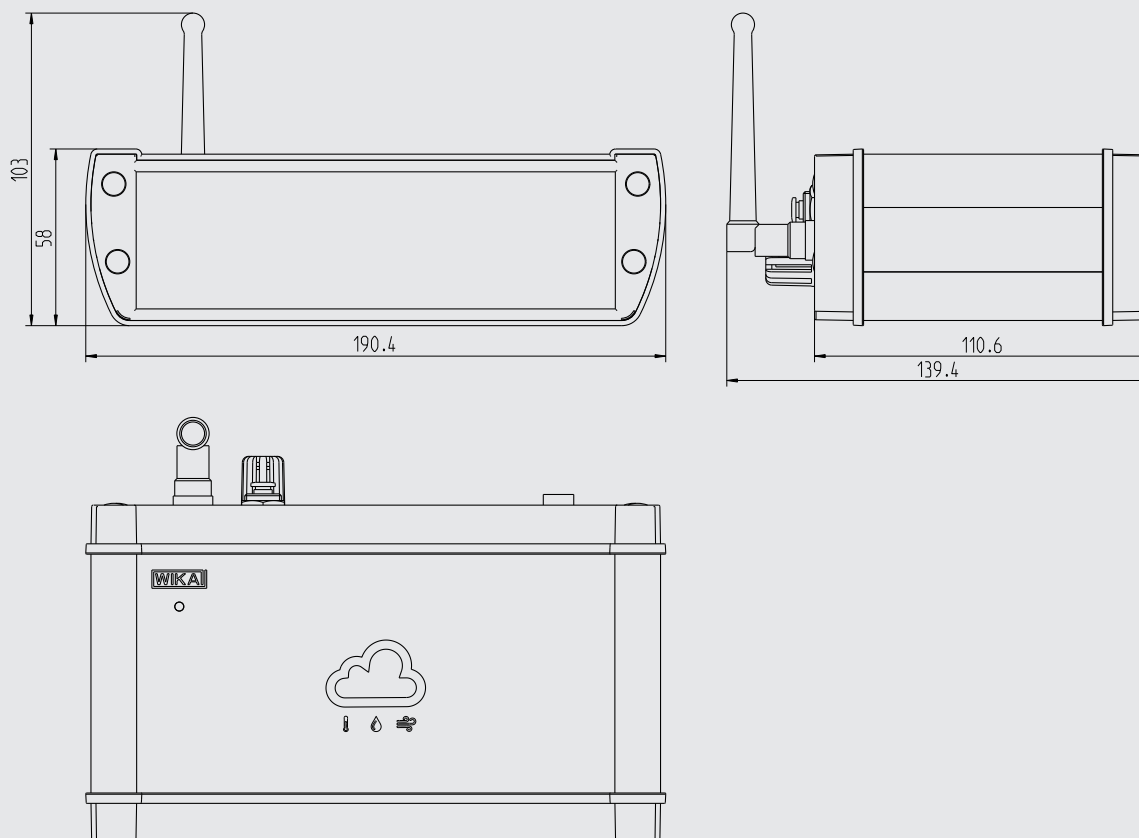

Pin assignment of the CPU6000-W

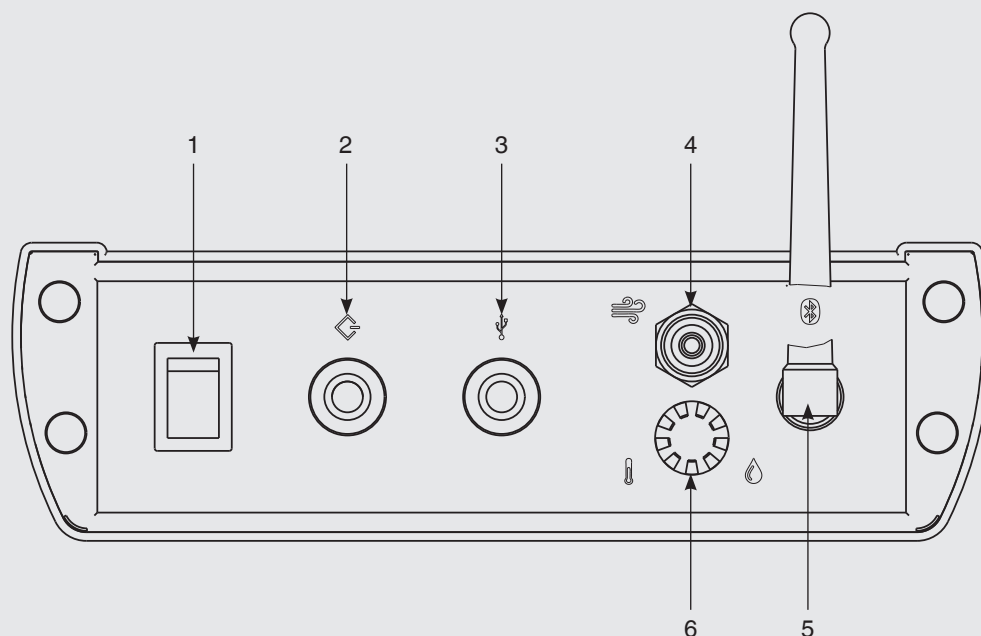

- | | |
|--|--|
| 1 On/Off switch | 5 Bluetooth® 4.0 antenna |
| 2 Power connection DC 24 V | 6 Exchangeable humidity-temperature sensor |
| 3 USB interface connector | |
| 4 4 mm hose connection for internal barometric reference | |

Pressure balance sensor box, model CPU6000-S

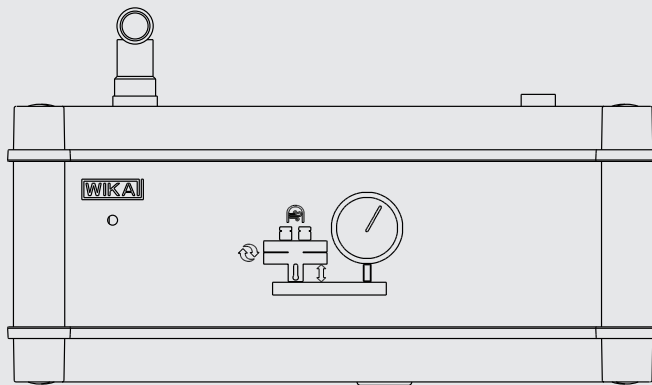
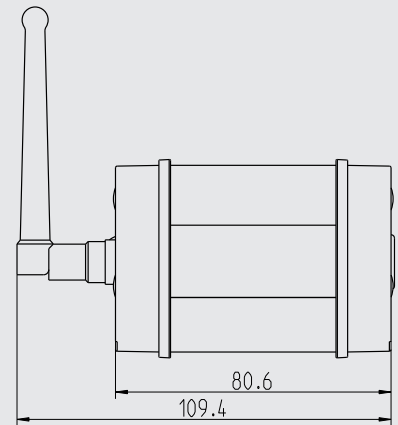
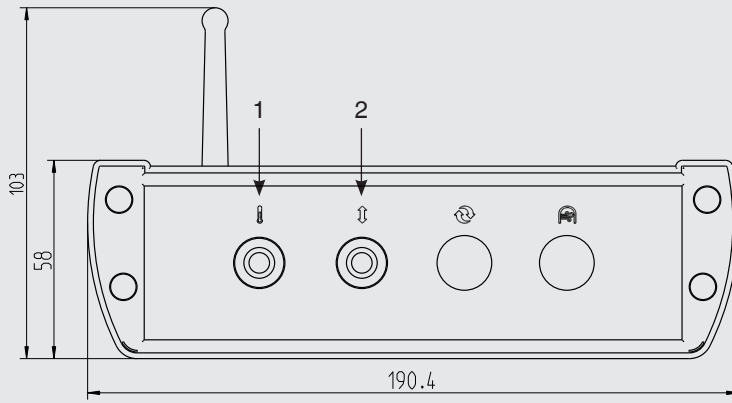

- 1 Piston temperature sensor connector
- 2 Floating position sensor connector

Digital multimeter, model CPU6000-M

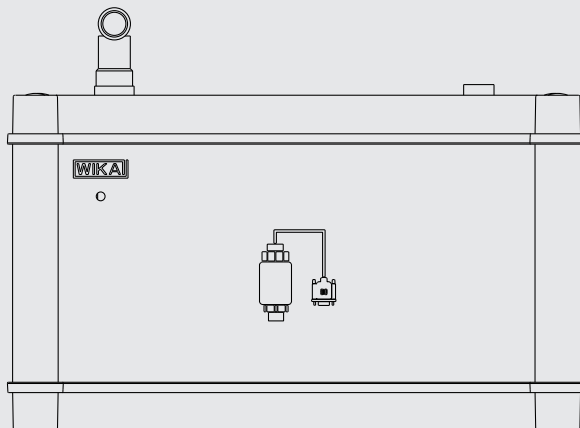
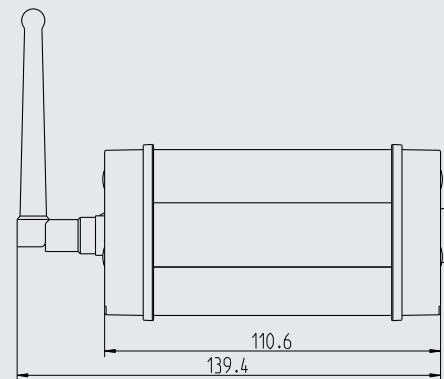
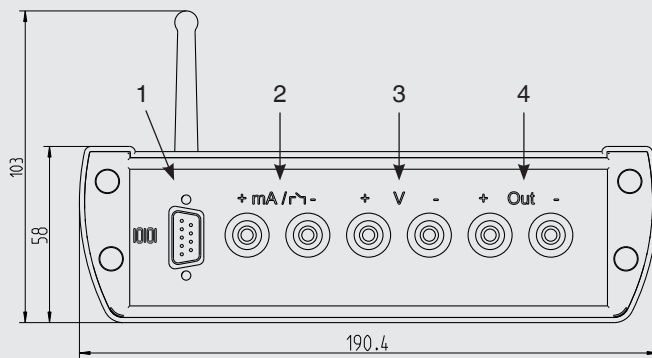

- 1 RS-232 interface connector
- 2 Current input
- 3 Voltage input
- 4 Voltage supply for test item

Pin assignment of the CPU6000-S and CPU6000-M

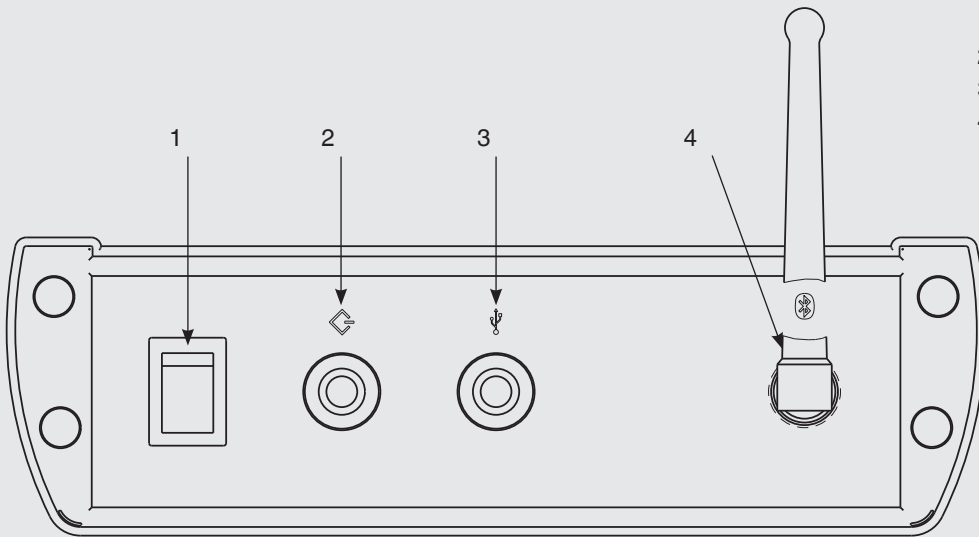

- 1 On/Off switch
- 2 Power connection DC 24 V
- 3 USB interface connector
- 4 Bluetooth® 4.0 antenna

Typical application

CPB series pressure balance and CPB-CAL iPad® app

Through the simple and user-friendly operation with the iPad® app, the mass discs to be applied for a given pressure value can be calculated. The CPU6000 series provides the required data, such as ambient parameters and piston temperature, so that the highest accuracy can be achieved. The CPU6000-S can be combined with pressure balances from all manufacturers. The sensor technology of the instrument has been optimised for installation into CPB series pressure balances.



Model CPU6000-W, CPU6000-S, CPB5800 and iPad® app CPB-CAL

CPB series pressure balance and WIKA-CAL PC software

With the demo version of the WIKA-CAL software and a CPB series pressure balance, the mass discs to be applied and the corresponding reference pressure can be determined. The pressure balance data can be entered into the database manually or imported automatically via an online XML file. With the CPU6000 series instruments, the accuracy can be further increased. With the CPU6000-W, the ambient conditions can be measured, and with the CPU6000-S, the piston temperature can be measured and these can be taken into account in the calculations. As an additional parameter, the local gravity value can be given for location-independent measurements.

If a pressure transmitter is being calibrated, this can automatically be read with the CPU6000-M. Through the WIKA-CAL software and this automatic reading, the calibration can even be made completely automatically in conjunction with a pressure controller.



Model CPU6000-W, CPU6000-S, CPB5800 and PC with WIKA-CAL software

iPad® app CPB-CAL

- Bluetooth® 4.0 communication (only with iPad® 3 or later) to all CPU6000 models with graphical evaluation of the measured values.
- The pressure or the mass can be given in order to calculate the corresponding reference mass or pressure.
- Via an online available database of pressure balance data, information generated by WIKA can be imported as an XML file.



iPad® app CPB-CAL

Accessories

Floating position sensor for model CPU6000-S

With the floating position sensor, in conjunction with the CPU6000-S, the displacement of the masses can be graphically displayed in the CPB-CAL iPad® app or in WIKA-CAL. Through the automatic detection of the floating position, the software can automatically move to the next calibration point.



Floating position sensor for model CPU6000-S

Wall mounting for models CPU6000-W, CPU6000-M and CPU6000-S

With this integrated mount for the CPU6000 series, the instrument can be mounted, not just on a wall, but also under a table or on the ceiling.



Model CPU6000-W
Left: with wall mounting
Right: without wall mounting

Scope of delivery

- Model CPU6000-W, model CPU6000-S or model CPU6000-M
- AC adapter, DC 24 V, 625 mA
- Factory calibration certificate
- Operating instructions in German and English language

Option

- DKD/DAkkS calibration certificate
- USB interface cable
- Wall mount

CPU6000-W

- WIKA sensor, 550 ... 1,150 mbar abs., accuracy 0.05 % FS (standard)
- Sensor sensor, 551 ... 1,172 mbar abs., accuracy 0.01 % of reading

CPU6000-S

- Piston temperature sensor with 1 m cable (standard)
- Piston temperature sensor with 2.5 m cable
- Floating position sensor with 1 m cable, accuracy ± 0.5 mm (standard)
- Floating position sensor with 2.5 m cable, accuracy ± 0.5 mm

For CPU6000-M

- Test-cable set, consisting of 4 test cables, each with crocodile clamps and banana jack connector adapter in black and red

Accessories

Voltage supply

- AC adapter, DC 24 V, 625 mA

Communication

- USB interface cable

For CPU6000-S

- Floating position sensor with 1 m cable, accuracy ± 0.5 mm
- Floating position sensor with 2.5 m cable, accuracy ± 0.5 mm
- Floating position sensor with 1 m cable, accuracy ± 0.5 mm for installation
- Floating position sensor with 2.5 m cable, accuracy ± 0.5 mm for installation
- Piston temperature sensor with 1 m cable
- Piston temperature sensor with 2.5 m cable
- Piston temperature sensor with 1 m cable for installation
- Piston temperature sensor with 2.5 m cable for installation
- Wall mount

For CPU6000-W

- Temperature-humidity sensor
- Wall mount

For CPU6000-M

- Test-cable set, consisting of 4 test cables, each with crocodile clamps and banana jack connector adapter in black and red
- Wall mount

Ordering information

Model / Package / Barometric reference / Piston temperature sensor / Floating position sensor / Wall mount / USB interface cable / Test-cable set / Calibration / Accessories

© 2013 WIKA Alexander Wiegand SE & Co. KG, all rights reserved.
The specifications given in this document represent the state of engineering at the time of publishing.
We reserve the right to make modifications to the specifications and materials.

