

MEDUSA 510 / 511 SERIES



Isotech North America
158 Brentwood Drive, Unit 4
Colchester, VT 05446

Phone: 802-863-8050
Fax: 802-863-8125

www.isotechna.com
sales@isotechna.com

The company is always willing to give technical advice and assistance where appropriate. Equally, because of the programme of continual development and improvement we reserve the right to amend or alter characteristics and design without prior notice. This publication is for information only.

CONTENTS



<u>PAGE</u>	<u>DESCRIPTION</u>
3 - 4	EMC Information
5	Health & Safety Instructions
6	Do's and Don'ts
7	Guarantee
8	Cautionary Note
9	Transit Clamp Notice
10,	Unpacking & Initial Inspection
11,12,13	Introduction
14,15	Mode of Operation
16	Adjusting the Timer
17,18	Thermometric Fixed Points (a tutorial note)
19	How to measure the true temperature inside the accessories supplied with the Medusa
20	Specification
21,22	Performance Graphs
23,24	Operating the Controller
25,26,27,28	Operating the Indicator
29,30	Connecting a Current Transmitter (up to 20mA) Selecting Configuration Level Testing Thermostats
31	Operating the Medusa 511
32	Using the PC Interface
33,34	Using Cal Notepad
35	Diagnostics
36	Initial Testing
37	Maintenance
38	Figure 2
39	Figure 3
40	Appendix 1 - Trouble Shooting
41,42	Appendix 2 - Accessories
43,44	Appendix 3 - Indicator Configuration



EMC INFORMATION

This product meets the requirements of the European Directive on Electromagnetic Compatibility (EMC) 89/336/EEC as amended by EC Directive 92/31/EEC and the European Low Voltage Directive 73/25/EEC, amended by 93/68/EEC. To ensure emission compliance please ensure that any serial communications connecting leads (RS232 or RS422(485)) are fully screened.

The product meets the susceptibility requirements of EN 50082-1, criterion B.

Symbol Identification	Publication	Description
	ISO3864	Caution (Refer to Handbook)
	IEC 417	Caution, Hot Surface



ELECTRICAL SAFETY

This equipment must be correctly earthed.

This equipment is a Class 1 Appliance. A protective earth is used to ensure the conductive parts can not become live in the event of a failure of the insulation.

The protective conductor of the flexible mains cable which is coloured green/yellow **MUST** be connected to a suitable earth.

The blue conductor should be connected to Neutral and the Brown conductor to Live (Line).

Warning: Internal mains voltage hazard. Do not remove the panels.

There are no user serviceable parts inside. Contact your nearest Isotech agent for repair.

Voltage transients on the supply must not exceed 2.5kV.

Conductive pollution, eg. Carbon dust, must be excluded from the apparatus. EN61010 pollution degree 2.

The apparatus has two input connectors for temperature sensors, see Figure 2. These inputs are only suitable for either a thermocouple or resistance thermometer. No other sensor or signal may be connected.

ENVIRONMENTAL RATINGS

Operating Temperature 5-35 °C

Relative Humidity 5-95%, non condensing



HEALTH AND SAFETY INSTRUCTIONS

1. Read all of this handbook before use.
2. Wear appropriate protective clothing.
3. Operators of this equipment should be adequately trained in the handling of hot and cold items and liquids.
4. Do not use the apparatus for jobs other than those for which it was designed, ie. the calibration of thermometers.
5. Do not handle the apparatus when it is hot (or cold), unless wearing the appropriate protective clothing and having the necessary training.
6. Do not drill, modify or otherwise change the shape of the apparatus.
7. Do not dismantle the apparatus.
8. Do not use the apparatus outside its recommended temperature range.
9. If cased, do not return the apparatus to its carrying case until the unit has cooled.
10. There are no user serviceable parts inside. Contact your nearest Isotech agent for repair.
11. Ensure materials, especially flammable materials are kept away from hot parts of the apparatus, to prevent fire risk.

MEDUSA MODEL 510/511

'DO'S AND DON'TS'

DO NOT handle the accessories when they are very hot or very cold.

DO NOT place hot or cold accessories back in the carrying case

DO NOT use the pocket designed for the black body source sensor to measure the temperature of the insert or surface calibrator.

DO use that pocket for pre-warming or storage.

DO NOT spill liquids inside the Medusa.

DO NOT rely on the controller to tell you the temperature of the insert. It's job is only to provide an isothermal volume. It is the calibrated working standard that is used to measure actual temperature.

GUARANTEE

This instrument has been manufactured to exacting standards and is guaranteed for twelve months against electrical break-down or mechanical failure caused through defective material or workmanship, provided the failure is not the result of misuse. In the event of failure covered by this guarantee, the instrument must be returned, carriage paid, to the supplier for examination and will be replaced or repaired at our option.

FRAGILE CERAMIC AND/OR GLASS PARTS ARE NOT COVERED BY THIS GUARANTEE

INTERFERENCE WITH, OR FAILURE TO PROPERLY MAINTAIN THIS INSTRUMENT MAY
INVALIDATE THIS GUARANTEE

RECOMMENDATION

The life of your **ISOTECH** Instrument will be prolonged if regular maintenance and cleaning to remove general dust and debris is carried out.

Serial No:.....

Date:.....



Isotech North America
158 Brentwood Drive, Unit 4
Colchester, VT 05446

Phone: 802-863-8050
Fax: 802-863-8125

www.isotechna.com
sales@isotechna.com



CAUTIONARY NOTE

ISOTECH PRODUCTS ARE INTENDED FOR USE BY TECHNICALLY TRAINED AND COMPETENT PERSONNEL FAMILIAR WITH GOOD MEASUREMENT PRACTICES.

IT IS EXPECTED THAT PERSONNEL USING THIS EQUIPMENT WILL BE COMPETENT WITH THE MANAGEMENT OF APPARATUS WHICH MAY BE POWERED OR UNDER EXTREMES OF TEMPERATURE, AND ARE ABLE TO APPRECIATE THE HAZARDS WHICH MAY BE ASSOCIATED WITH, AND THE PRECAUTIONS TO BE TAKEN WITH, SUCH EQUIPMENT.

TRANSIT CLAMP

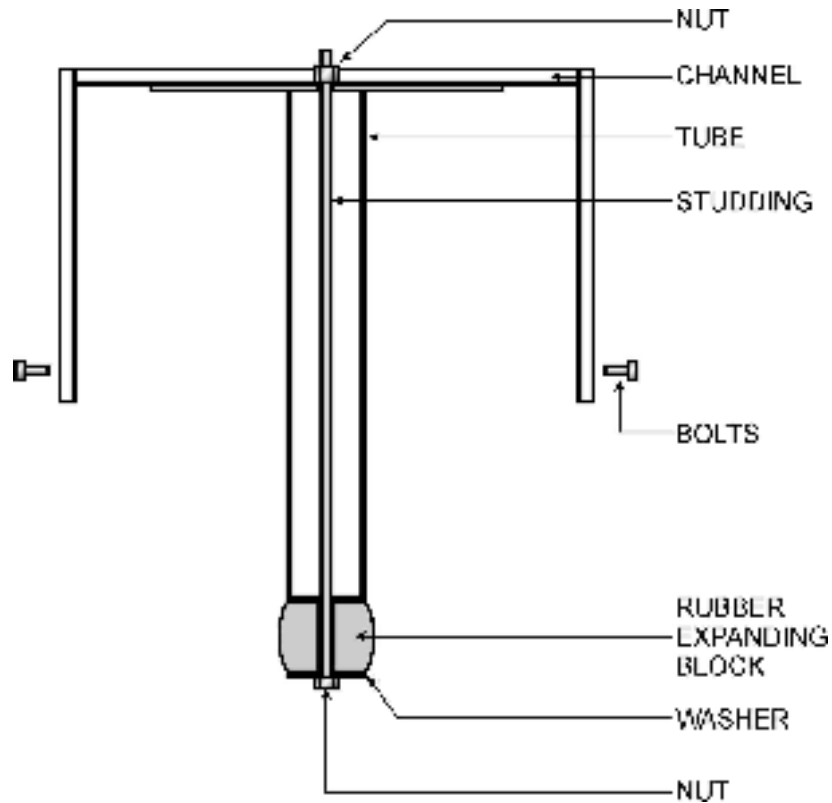

EVERY EFFORT HAS BEEN MADE TO PACKAGE THIS UNIT FOR TRANSPORT AND TO ENSURE ITS GOOD CONDITION ON ARRIVAL AT ITS DESTINATION

BEFORE COMMISSIONING IT IS NECESSARY TO REMOVE THE FURNACE CORE TRANSIT CLAMP. TO AVOID DAMAGE PLEASE FOLLOW INSTRUCTIONS

1. Slacken the central nut using the required tube spanner; the insertion of a screwdriver through the tube spanner will prevent the central stud turning.
2. Remove the 4 bolts securing the transit clamp to the side of the unit. Slacken each screw equally by degrees and then completely remove the screws.
3. Gently lift the transit clamp vertically; a central tube which has secured the furnace core will then slide out. The 4 screws should then be replaced to secure the handles to the side of the unit.
4. Normal commissioning procedure may now be followed.
5. Keep the transit clamp and use it if the furnace is ever transported.

UNPACKING AND INITIAL INSPECTION

Our Packing Department uses custom designed packaging to send out your unit, but as accidents can still happen in transit, you are advised, after unpacking the unit, to inspect it for any sign of shipping damage, and confirm that your delivery is in accordance with the packing note. If you find any damage or that part of the delivery is missing notify us or our agent, and the carrier immediately. If the unit is damaged you should keep the packing for possible insurance assessment.

ELECTRICITY SUPPLY

Before connecting to the electricity supply please familiarise yourself with the parts of the handbook relevant to your model.

Your unit's supply voltage requirement is specified on a plate on the instrument along with the serial number. All Medusa instruments will work on an electricity supply frequency of 50Hz or 60Hz.

The apparatus is provided with an approved power cord. If the plug is not suitable for your location

at
ion



then the plug should be removed and replaced with an appropriate plug.

Take care to ensure the old plug is disposed safely.

The cable is colour coded as follows:

<u>COLOUR</u>	<u>FUNCTION</u>
Green/yellow	Earth (Ground)
Brown	Live (line)
Blue	Neutral

Please ensure that your unit is correctly connected to the electricity supply.

THE APPARATUS MUST BE CORRECTLY EARTHED (GROUNDED)

**MEDUSA 510/511 SERIES
HANDBOOK
ISSUE 10 - 11/05**

The units on/off switch is located on the power inlet. Take care NOT to switch the unit off when it is hot - allow to cool first.

INTRODUCTION

The Medusa range of products allows unprecedented flexibility for the calibration of temperature sensors. The Medusa may be used with the following options:

1. An ITS-90 Fixed Point Apparatus
2. As a Metal Block Bath
3. A Black Body Source
4. A Surface Sensor Calibrator

The Medusa is available in two variants. The Basic (B) model which incorporates a single temperature controller. The Potts and Site (S) model also include a temperature indicator and timer.

COMPARISON CALIBRATION:

By definition, one compares industrial thermometers to a calibrated standard.

There are 3 methods commonly used.

1) **USING THE CONTROLLER**

Using the controller as the “calibrated standard” this method means that the complete bath is calibrated by comparing the controller reading to a calibrated standard placed in the bath.

This is a common method but is unsafe since the control sensor is

- a) inaccessible
- b) in the wrong place to give correct temperature of the insert

For these reasons it fails to satisfy ISO9000 and gives large uncertainties.

2) **USING THE INDICATOR - (Not Basic (B) Model)**

Here an indicator and external calibrated sensor are used to measure the temperature of the insert. This arrangement gives good accurate and reliable results. To recalibrate however it does mean sending the whole calibrator back to the calibration laboratory. This, the calibrator is self-contained, self-sufficient and meets ISO9000 requirements.

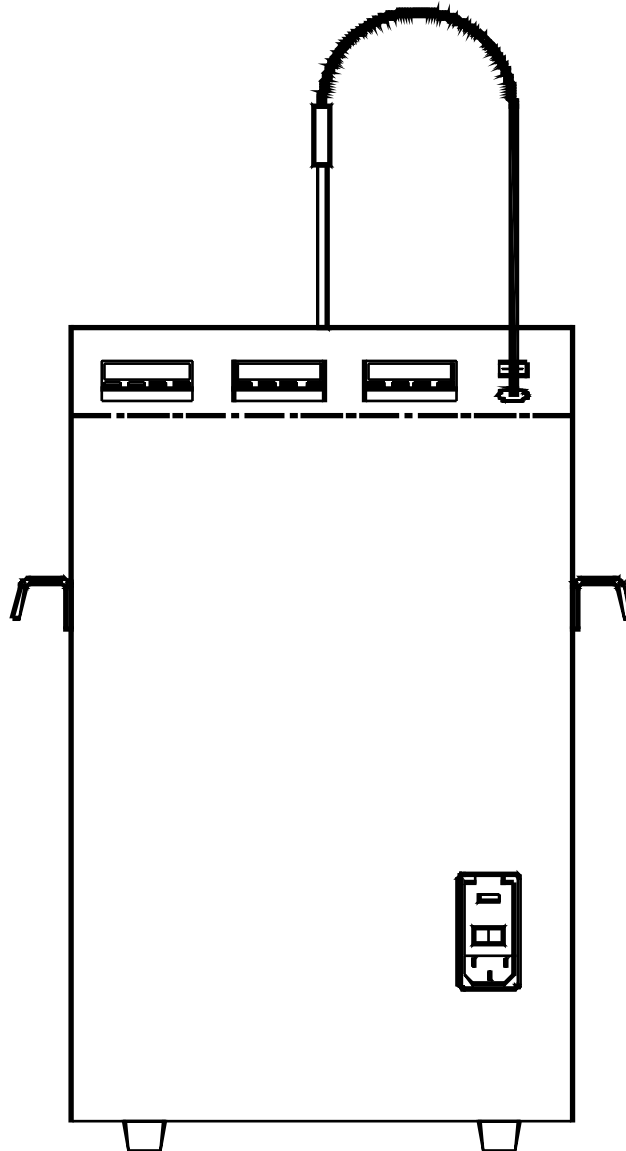

3) **USING EXTERNAL STANDARDS**

Here a separate indicator and calibrated sensor are used to measure the inserts temperature. This can give the most accurate and reliable results, depending on the indicator.

It means that the calibrator does not need calibrating only the indicator and it's calibrated sensor need re-calibration, but this option is more bulky, expensive and less portable than 2) It also meets ISO9000 requirements.

MODE OF OPERATION

1) **ITS-90 FIXED POINT CALIBRATION**

The ITS-90 fixed point function of the Medusa is well suited for fast, convenient, mess free calibration of thermometers to uncertainties as low as 0.001 °C.

The special cell is placed into the Medusa calibration well.

The equipment incorporates a timer which can change temperatures to allow MELTING or FREEZING of a Cell. Once initiated the Cell can be arranged to be on the melt plateau during the day and automatically frozen and brought back to the melt plateau overnight.

It works this way:-

The Medusa automatically switches on some 2 to 3 hours before the working day starts and gets the cell onto its melt plateau. The indicator tells the user on their arrival in the morning that the melt has begun and calibration can commence.

If left unused the melt continues to 6 to 12 hours and probably during the night the timer switches the apparatus off to re-freeze the cell, the cycle is repeated each day, giving the user the fixed point all day, every day without attention except to occasionally clean the fan filter if it becomes clogged with dust.

The Medusa works by having a controller which is set about 1 °C above the fixed point which is inside the apparatus. It has an indicator with a thermometer which is used to monitor the state of the fixed point cell. It is also fitted with a timer to automatically switch on and off the apparatus.

Indium, Tin Lead and Zinc Fixed Points all look the same, being an ingot of pure metal placed in a graphite crucible which, to keep dirt, moisture and air out are sealed, usually in quartz glass. To avoid the use of quartz glass the graphite crucibles are sealed into metallic containers without contamination of the pure ingot inside the crucible.

On power up the timer is set to run at setpoint 1 for 20 hours at setpoint 2 for 4 hours.

2) **METAL BLOCK BATH**

The metal block bath function of the Medusa is well suited for fast, convenient, mess free calibration of temperature sensors.

The Medusa metal insert is placed into the calibration well.

The thermometers under test are placed into suitable holes in metal insert, see accessory page. A calibrated reference probe should be placed into the insert and the actual temperature can be read from the temperature indicator.

For traceable calibration the actual value of the insert temperature should be recorded along with the values from the sensors under test.

3) **BLACK BODY SOURCE**

The black body function of the Medusa is well suited for fast, convenient, mess free calibration of infra-red temperature sensors.

The Medusa black body target, see accessory page, is placed into the calibration well. The units under test should be aligned with the target.

A calibrated reference probe should be placed into the hole in the block and the actual temperature can be read from the temperature indicator to which the infra red thermometer(s) are compared.

4) **SURFACE SENSOR CALIBRATION**

The surface sensor function of the Medusa is well suited for fast, convenient, mess free calibration of most surface temperature sensors.

The Medusa surface sensor insert, see accessory page, is placed into the calibration well.

A calibrated probe, see accessory page, is placed in the pocket of the surface sensor insert and connected to the temperature indicator. Surface sensors are placed on top of the insert and when stable compared to the calibrated probe.

ADJUSTING THE TIMER



Programming the Timer (not Basic models)

- 01 Remove the Power Supply from the Unit.
- 02 Press down and hold the SET button for five seconds, until the timing mode currently selected begins to flash.
- 03 Press the Up Arrow button until ICY+ is flashing and press SET to select.
- 04 The decimal place and timing ranges should now be flashing, with the ICY+ symbol showing in timing mode area. Use the Up Arrow until the timing range is set to HRS (hours) and the Set Time is set for a single decimal place. Press the SET button to proceed.
- 05 The decimal place and timing ranges should now be flashing, with the ICY- symbol showing in timing mode area. Use the Up Arrow until the timing range is set to HRS (hours) and the Set Time is set for a single decimal place. Press the SET button to proceed.
- 06 The display will now flash the ^ or the v symbol in the top left corner. Use the Up Arrow button to alternate between the two. Press SET to select. The ^ means that when operating the display will show the time elapsed, and v means that the display will show the time remaining.
- 07 Now with ICY+ showing the first digit will be flashing. To set the time spent freezing use the Up Arrow button to select the required value. Press SET. The Second digit will now flash, use the Up Arrow button to select the required value. Press SET. The last digit will now flash, set the final digit with the Up Arrow button and press SET to proceed.
- 08 Now with ICY- showing the first digit will be flashing. To set the time spent melting use the Up Arrow button to select the required value. Press SET. The Second digit will now flash, use the Up Arrow button to select the required value. Press SET. The last digit will now flash, set the final digit with the Up Arrow button and press SET.
- 09 The display will now become blank. The setup is complete and the unit is now ready for use.
- 10 Upon powering up the unit will begin to freeze.

THERMOMETRIC FIXED POINTS (a tutorial note)

Temperature scales used in science and industry are defined by a series of "fixed points", which are realised by establishing thermal conditions under which pure materials exhibit equilibrium between two or three phases. A scale assigns numerical values to the temperatures at which these phase equilibria exist. For example, the temperature at which pure water exists simultaneously in its liquid, solid and gas phases (triple point) has been assigned the numerical value of 0.01 °C on the International Temperature Scale, and the value of 273.16K on the Kelvin Thermodynamic Temperature Scale. Examples of other defining fixed points of the International Temperature Scale of 1990 are the respective liquid-solid equilibria of tin, zinc and silver under 1 standard atmosphere pressure.

In some important disciplines it is desirable to realise a thermometric fixed point between 0 and 100 °C, frequently in the vicinity of body or environmental-temperature. The melting temperature of high purity gallium, 29.7646 °C, is a fixed point that can be useful in this context.

The solid-liquid equilibrium point of gallium is realised in cells such as those shown in figure 1. A quantity of pure gallium is contained in a vessel which provides, also, a re-entrant well for insertion of a thermometer. The cycle for realising the melt equilibrium is as follows:

The gallium starts in a single phase, assumed for present purposes to be liquid. The cell is placed in a cold environment until the gallium has solidified. The phase-change of the metal can be determined by tracing the temperature of the well. As the metal cools from the liquid phase, the temperature will begin to fall. An initial smooth drop in temperature will be observed, and then at some temperature below the freezing temperature there will be seen a reversal and a subsequent rise in temperature. This "undercool" phenomenon is characteristic of many pure materials, most of which can remain liquid at temperatures below their normal freezing points (if the metal were initially solid, the temperature would fall uninterrupted to that of the cold environment).

The reversal takes place as the first crystalline solid forms in the liquid; the temperature rises to the liquid-solid equilibrium plateau temperature as the metal gives up latent heat on freezing, remaining thereafter at this temperature until the metal is completely solid. Beyond this stage there will be a smooth drop in temperature to that of surrounding environment.

To establish the melting condition, the cell is then transferred to an environment maintained at a temperature slightly above the melt temperature of gallium. This environment may be a stirred fluid bath of sufficient heat capacity and control capability, or may be the Medusa POTTs or Gallium Temperature Standard Apparatus Model 17402B which is designed automatically to raise the temperature of the cell to initiate melting of the metal and then to maintain it at a correct level. The temperature to which the cell is exposed to melt the metal does not determine the solid-liquid equilibrium temperature, but it can have a substantial effect on the duration of the (constant-temperature) melt plateau.

The monitoring thermometer will indicate a rise in temperature in the well as the solid gallium approaches the melt temperature. Then, beyond the instant at which liquid first begins to form, the temperature will remain constant until all the metal has melted. The end of the melt plateau is signalled by a rise in well temperature to the temperature of the surrounding environment. An ITL 17401 gallium cell used in the Model 17402B system can give a plateau duration of at least 12 hours.

The melting cycle is now complete. The material in the cell is entirely in the liquid phase. Another cycle may be started immediately, if desired.

17cc of water should be poured into the re-entrant tube to allow proper conduction between cell and thermometer.

For the highest measurements (to ITS-90 value) an between switching commencing Alternatively, once water in the well warm water at say around the re-entrant additional guidance.

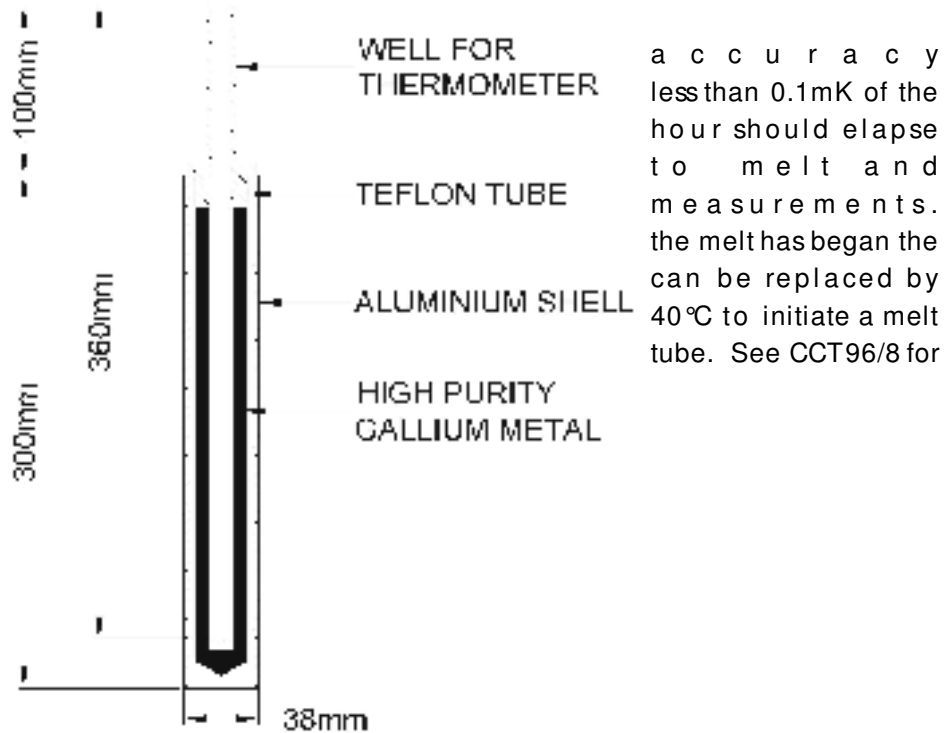

figure 1. GALLIUM CELL

HINT

**HOW TO MEASURE THE TRUE TEMPERATURE INSIDE THE ACCESSORIES SUPPLIED
WITH THE MEDUSA SERIES**

The controller of the Medusa controls and reads the temperature of the block surrounding the deep calibration well.

There are various accessories including the surface calibration insert, black body etc. These adapt the Medusa to perform varied calibration functions.

None of these accessories actually get to the block temperature and hence the controller's temperature because each accessory has a different immersion characteristic. For this reason the Medusa like all comparison baths requires a reference thermometer to indicate the true temperature inside the accessory.

Remember the following:-

THE CONTROLLER

The controller is used to set a constant temperature and create an isothermal environment for the comparison calibration of temperature sensors.

THE REFERENCE THERMOMETER

The Reference Thermometer is placed in the accessory or insert and measures the true temperature inside the insert or accessory.

THE INDUSTRIAL THERMOMETER

The Industrial thermometer is placed in the accessory or insert and is compared to the True Temperature as indicated by the reference thermometer. An insert will typically have a 1% immersion error. For more details see - Depths of Immersion. Tavener J. P. Volume 9.2. Isotech Journal of Thermometry pages 79-87.

SPECIFICATION

Voltage	:	230VAC (<u>or</u> 115VAC) see ratings plate
Power	:	1800W
Supply Frequency	:	50/60Hz
Maximum Operating Temperature	:	Medusa 1 - 550 °C Medusa 2/Medusa 511 - 700 °C
Minimum Operating Temperature	:	Medusa 1 - 30 °C Medusa 2/Medusa 511 - 35 °C
Stability (Absolute over 30 Minutes)		
Metal Block Bath	:	±0.03 °C
Black Body Source	:	±0.3 °C
ITS-90 Fixed Point Apparatus :		±0.0002 °C
Calibration Volume	:	45mm dia by 285mm deep
Standard Insert Hole Dimensions:	:	6 x 8mm

**MEDUSA 510/511 SERIES
HANDBOOK
ISSUE 10 - 11/05**

Insert Options	:	Standard 6x8mm x 250mm deep
	:	Adjustable Height Equalising Block
	:	Special drilling available to customer requirements.
	:	Blank
Dimensions (not including handle)	:	Height 430mm
		Width 310mm
		Depth 300mm
Weight	:	Medusa 1 - 17Kg
		Medusa 2/Medusa 511 - 26kg

MEDUSA 1 PERFORMANCE GRAPHS

MEDUSA 1 HEAT UP / COOL DOWN GRAPH

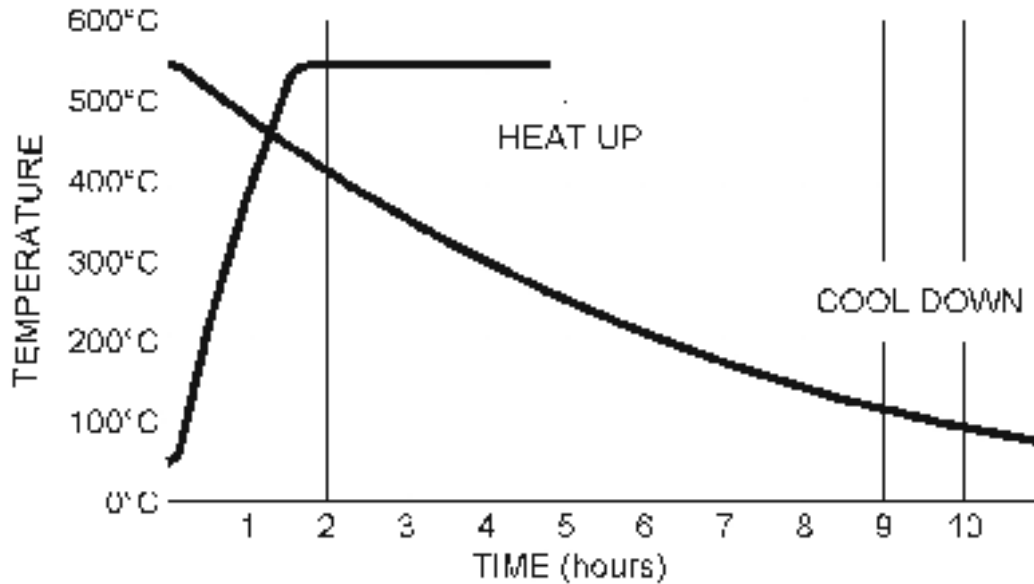

MEDUSA 1 UNCERTAINTY GRAPH

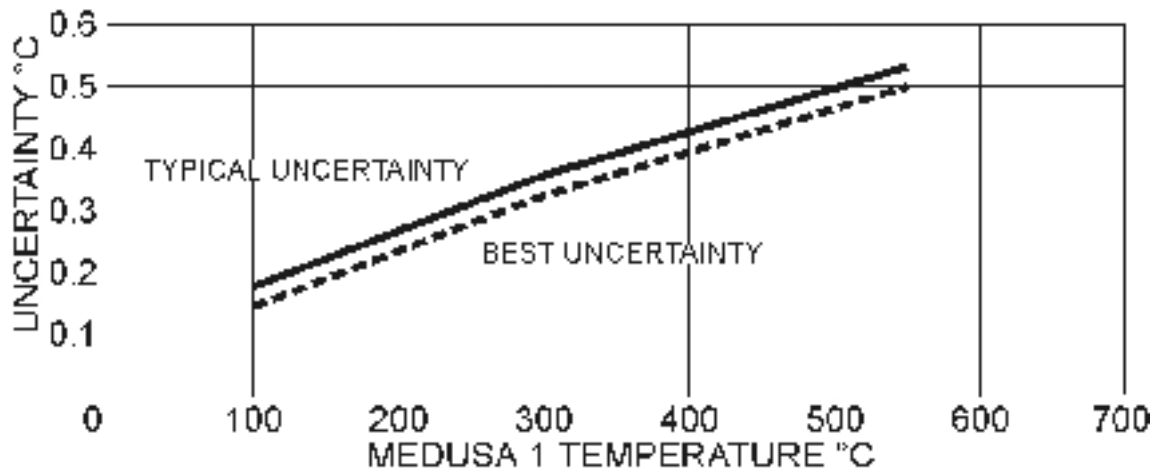

BEST UNCERTAINTY - USING TT12 AND A 935-14-95 CALIBRATED SYSTEM
 TYPICAL UNCERTAINTY - USING TT11 AND A 935-14-95 CALIBRATED SYSTEM

MEDUSA 2 PERFORMANCE GRAPHS

MEDUSA 2 HEAT UP / COOL DOWN GRAPH

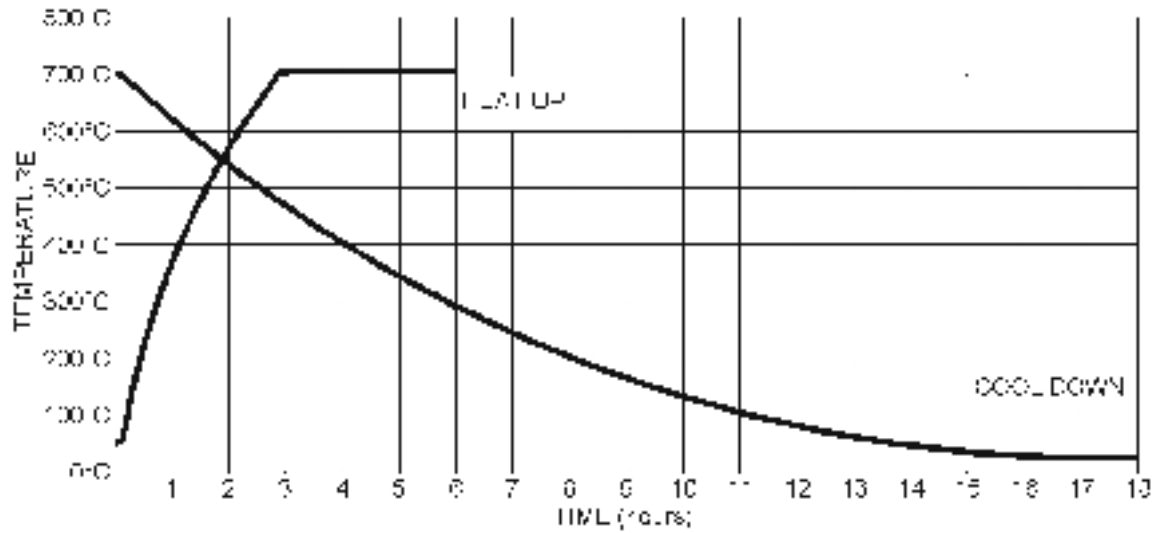

MEDUSA 2 UNCERTAINTY GRAPH

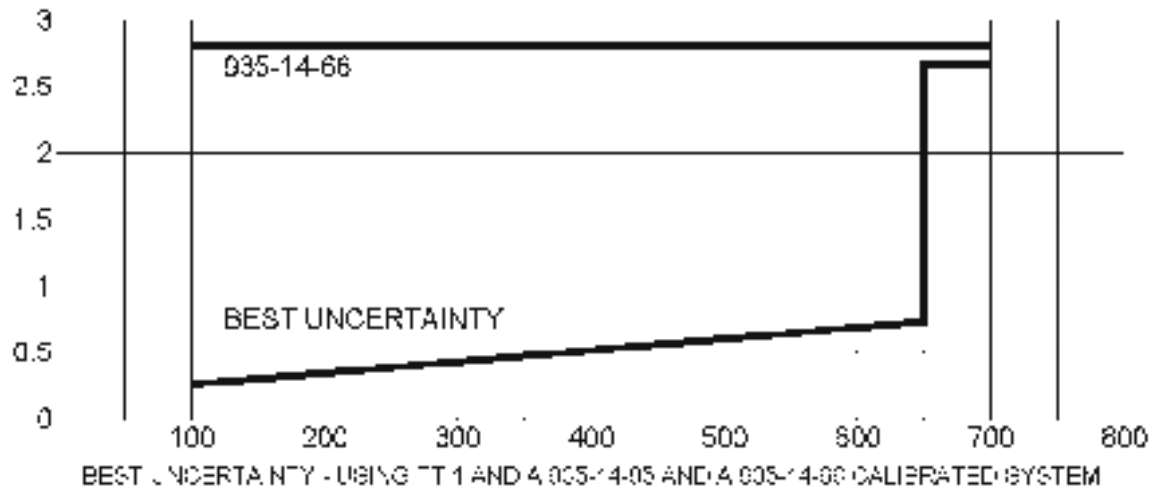

OPERATING THE MEDUSA

FRONT PANEL LAYOUT

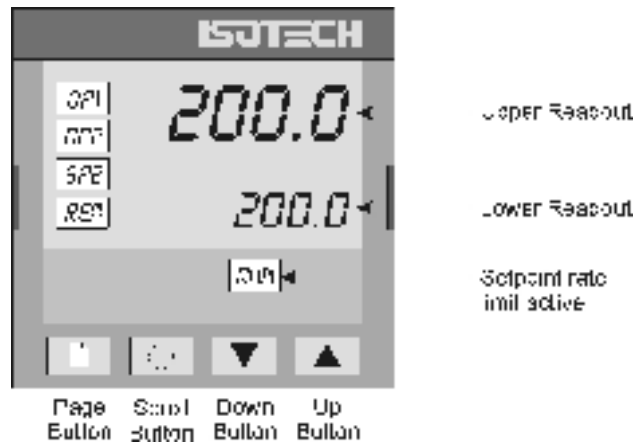

The Temperature Controller

The controller has a dual display, the upper display indicates the nominal block temperature, and the lower display indicates the desired temperature or setpoint.

Altering the Setpoint

To change the setpoint of the controller simply use the UP and DOWN keys to raise and lower the setpoint to the required value. The lower display changes to indicate the new setpoint.

Press scroll button to select setpoint 1 (SP1) or setpoint 2 (SP2).

Advanced Controller Features

Setpoint Ramp Rate

By default the Dry Blocks are configured to heat (and cool) as quickly as possible. There may be some calibration applications where it is advantageous to limit the heating (or cooling rate).

An example might be when testing bimetallic thermostats, by forcing the Dry Block to heat at a controlled rate it is easier to determine the temperature at which the thermostat changes state.

The Dry Block can have its heating rate limited with the Setpoint Ramp Rate feature. This feature is accessed from the Scroll key. Depress the key until the display shows,

SPrr

On the Upper Display, the lower display will show the current value from OFF (default) to 999.9. The desired rate is set here with the UP and DOWN keys, the units are °C/min.

When the SPrr is active the controller display will show "RUN", the lower setpoint display will now automatically update with the current value, known as the working setpoint. The setpoint can be seen by pressing either the UP and DOWN key.

The Setpoint ramp rate operates when the bath is heating and cooling.

Instrument Address

The controller has a configurable "address" which is used for PC communications. Each instrument has an address, this allows several instruments to be connected in parallel on the same communications bus. The default value is 1. This address would only need to be changed if more than one Dry Block is connected to the same PC port.

To check the Address value press the scroll key until the top display indicates,

Addr

The lower display will show the current value that can be modified with the UP and DOWN keys.

Monitoring the Controller Status

A row of beacons indicate the controllers status as follows,

OP1	Heat Output
OP2	Cool Output (Only for models which operate below 0 °C)
REM	This beacon indicates activity on the PC interface

Units

Momentary pressing the Scroll key will show the controller units °C or °F.

The Temperature Indicator (Not Basic (B) Models)

The site models include an electronic temperature indicator. The indicator can be configured for the desired sensor type, and for custom calibration data. The customer calibration data can be set ON or OFF.

Setting the Input Type

A 100 Ohm resistance thermometer can be connected to the PRT Connector or a thermocouple



may be connected to the miniature TC Connector.

Ensure that only a PRT or a TC is connected at any one time. If a PRT and TC are connected simultaneously the indicator will read in error.

Check that any sensor placed into the Medusa is suitable for the temperature range. Sensors can be damaged if taken outside their normal operating limits.

The desired sensor type is easily set, press the Scroll key until the upper display indicates,

inPt

On the upper display. The lower display will show the current set sensor type,

J.tc	J thermocouple
K.tc	K thermocouple
L.tc	L thermocouple
r.tc	R thermocouple (Pt/Pt13%Rh)
b.tc	B thermocouple (Pt30%Rh/Pt6%Rh)
n.tc	N thermocouple
t.tc	T thermocouple
S.tc	S thermocouple (Pt/Pt10%Rh)
PL.2	PL 2 thermocouple
rtd	100Ω platinum resistance thermometer.
T012	E thermocouple

Again the value can be modified with the UP and DOWN keys.

Enabling / Disabling Custom Calibration

Custom calibration allows the indicator to be programmed to suit a particular temperature sensor. This allows the indicator to automatically show the true temperature, without having to manually apply a correction.

When the Custom or User Calibration is active the indicator will show the REM beacon lit continuously. The use of User calibration can make a significant difference to the accuracy of

the instrument, and this REM beacon provides a clear and continuous indication of the calibration status. Isotech will configure and set user calibration when the Dry Block is ordered with a temperature sensor.

To alter the calibration status press the Scroll key until the upper display shows,

CAL

The lower display will indicate either,
USEr for user calibration

Or

FAcT for factory calibration of the indicator, i.e. User Cal OFF

Use the UP and DOWN keys to toggle between the two values.

When calibrating an unknown sensor against a calibrated probe it may be necessary to switch the calibration off for the unknown, and on for the calibrated probe.

Instrument Address

Like the controller, the indicator has a configurable "address" which is used for PC communications. Each instrument has an address; this allows several instruments to be connected in parallel on the same communications bus. The default value is 2 (The controller defaults to 1). This address would only need to be changed if more than one Dry Block is connected to the same PC port.

To check the Address value press the scroll key until the top display indicates,

Addr

The lower display will show the current value that can be modified with the UP and DOWN keys.

Monitoring the Indicator Status

For the indicator the REM beacon is lit continuously when the user calibration is active, the REM beacon flashes when the PC communications port is active.

Units

Momentary pressing the Scroll key will show the controller units °C or °F.

Advanced Indicator Operation

The indicator can be configured with up to five custom calibration points; the points contain "data pairs". First the temperature (point) and secondly the Error (offset) at this temperature point. Isotech Dry Block calibration certificates will show the values to suit a particular sensor.

These values can be inspected, and modified with the following procedure,

Press the PAGE key until the display indicates,

ACCS
LiSt

Press the SCROLL key until the display shows,

Goto
OPEr

Press the UP key until the display shows

Goto
conF

Press the Scroll Key twice, when the display will show,

inSt
Conf

Press the Page Key until the controller shows

CAL
Conf

Now use the Scroll key to examine the data pairs. The values can be modified with the UP and DOWN keys.

To exit this mode press the Page key until the top display shows,

Exit

And then set the lower display to YES. While in this mode take care not to modify other parameters - a full list of all the parameters can be found in appendix 3.

CALIBRATION DATA EXAMPLE

A maximum of five points may be entered, shown as Pnt 1 to Pnt 5 for the temperature point and Ofs 1 to Ofs 5 for the offset values.

The Pnt values must be entered in ascending order.

Set a Pnt to a value lower than the previous point to disable it.

The indicator would be programmed with the following data:

Pnt 1	100	Ofs 1	0.8
Pnt 2	300	Ofs 2	1.1
Pnt 3	500	Ofs 3	2.1
Pnt 4	-999	Ofs 4	0
Pnt 5	-999	Ofs 5	0

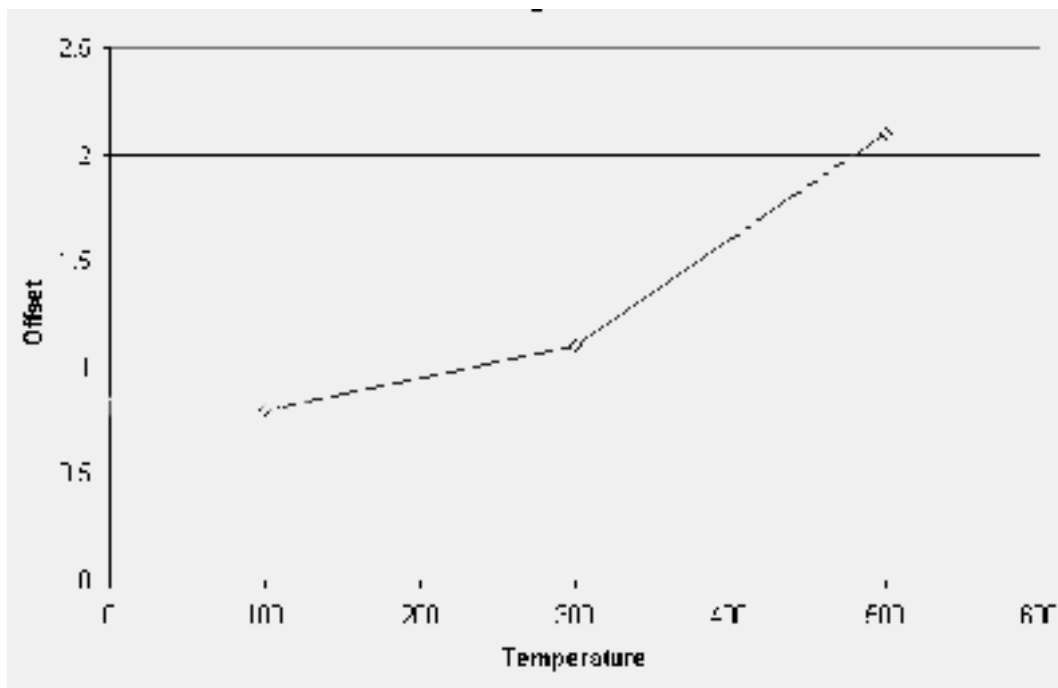

CONNECTING A CURRENT TRANSMITTER (UP TO 20MA)

The transmitter should be powered externally, a 2.49Ω current sense resistor is fitted internally and this allows the indicator to read mA.

1. From the input type menu select "mV".
2. Access configuration level.

SELECTING CONFIGURATION LEVEL

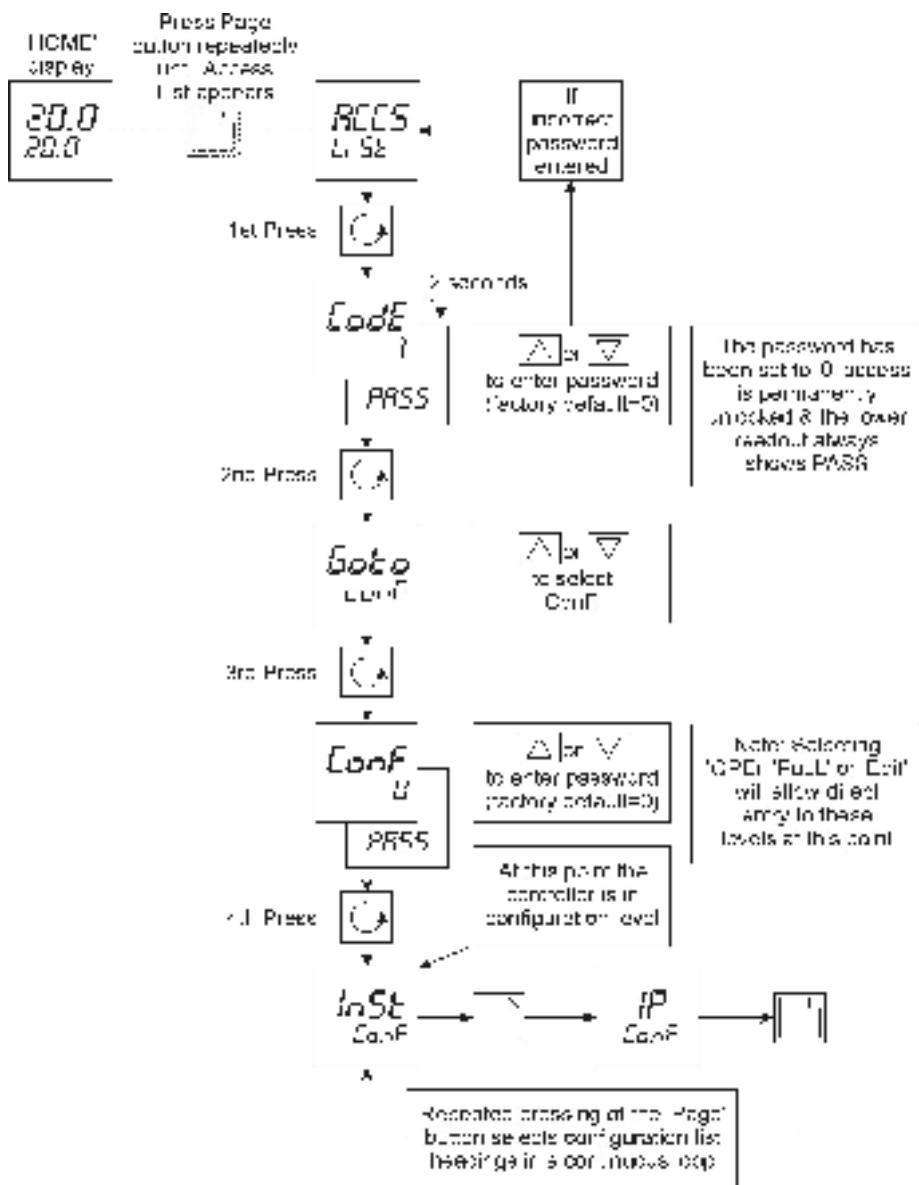

From the menu P set the INP.L, INP.H, VAL.L and VAL.H parameters to suit; see table below:

Linear Input Scaling - The next 4 parameters only appear if a linear input is chosen

e.g. 4 to 20mA = 0 to 100°C

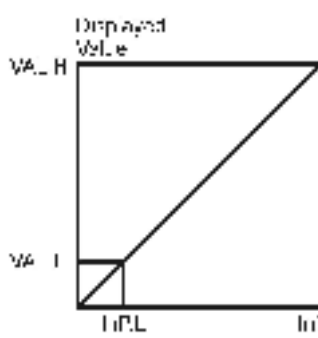

INP.L	Input value low	e.g. 4mA set 9.90
INP.H	Input value high	e.g. 20mA set 49.8
VAL.L	Displayed reading low	0°C
VAL.H	Displayed reading high	100°C

E.g. 4-20 mA = 0 to 100°C

INP.L	9.90 (mV)	(4mA x 2.450)
INP.H	49.8 (mV)	(20mA x 2.490)
VAL.L	0 (°C)	
VAL.H	100 (°C)	

Exit config level by pressing PAGE key or if the top display shows Exit, use the UP key to select YES, after two seconds the instrument will reset.

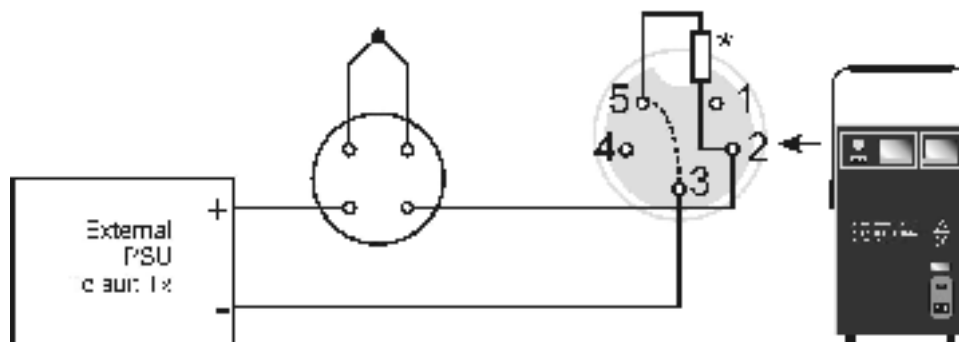

72.49Ω resistor fitted internally (Pins 2 and 5).
 Link Pins 3 and 5 for transmitter inputs.
 Remove link for I/C's and P/R's.
 Socket Pins shown Top Panel View

Testing Thermostats

The Site model can be used the Isotech Cal Notepad software for the testing of thermostats and other thermal switches with volt free contacts. Cal Notepad can capture the temperature at which a switch opens or closes. It can also perform a hysteresis test. Refer to the Cal Notepad manual for details. Ensure only voltage free contacts are connected. Do not allow any voltage signal to be connected - doing so many damage the equipment and present a safety hazard.

OPERATING THE MEDUSA 511

The Medusa 511 is a 3 Zone Block Bath used to create an even temperature profile along the part of the block in which fixed point cells will sit.

The main heater is used to set the required temperature the top and bottom heaters are used to compensate for the end effect heat losses.

The top and bottom heater control settings are preset for the Aluminium Point - unless the Medusa is supplied with an alternative ITS-90 fixed point.

To change the offsets (e.g for tin and indium points) the offsets may need to be reduced. The offsets are simply changed with the up and down buttons of the respective controller.

As a first approximation the offsets may be reduced proportionally with temperature.

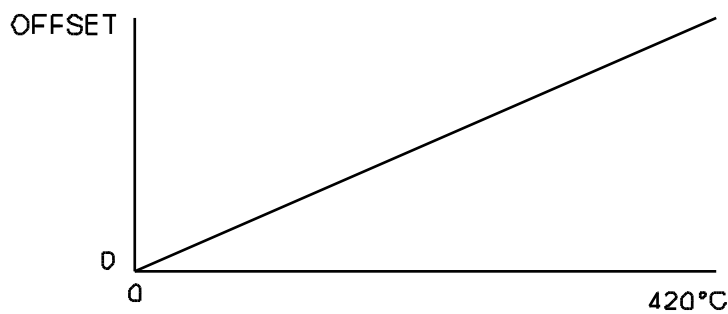

Offsets may be checked and optimized by placing a small thermocouple adjustment to the block thermocouple and then the controllers.

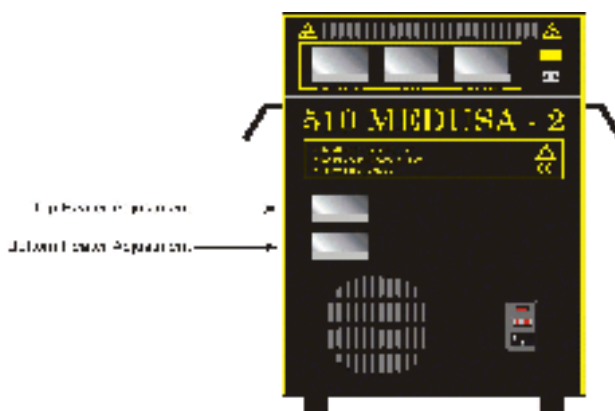

be checked and optimized by small thermocouple adjustment. By raising and lowering the e the profile can be obtained optimise by adjustment of the

Using the PC Interface

The Plus models include an RS422 PC interface and a special converter cable that allows use with the a standard RS232 port. When using the bath with an RS232 port it is essential that this converter cable is used. Replacement cables are available from Isotech, part number ISO-232-432. A further lead is available as an option, Part Number ISO-422-422 lead which permits up to 5 instruments to be daisy chained together.

The benefit of this approach is that a number of calibration baths may be connected together in

a
 s y
 i n "
 figu
 on -
 the
 link
 to a
 gle
 232
 see
 gra

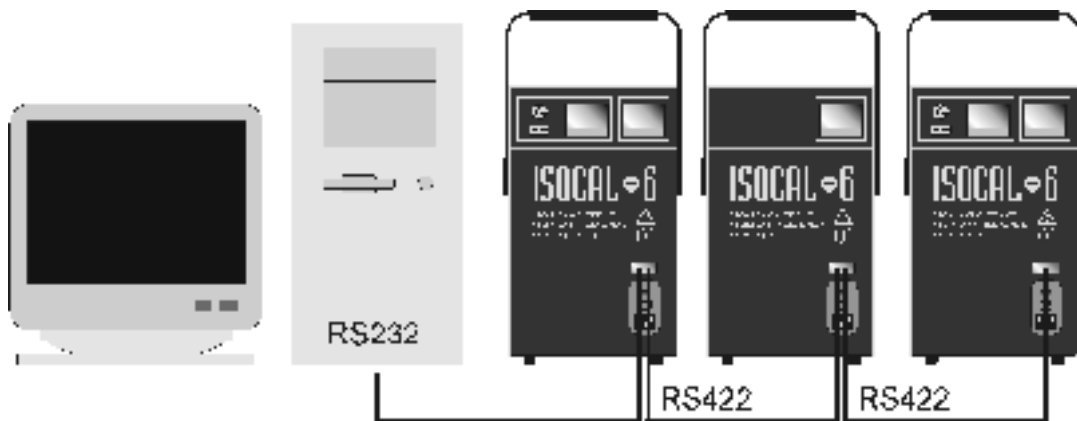

"dai
 cha
 con
 rati
 and
 n e d
 s i n
 R S
 , dia
 m.

Note: The RS 422 standard specifies a maximum lead length of 1200M (4000ft). A true RS422 port will be required to realise such lead lengths. The Isotech conversion leads are suitable for maximum combined lead lengths of 10M that is adequate for most applications.

Connections

For RS232 use simply connect the Isotech cable, a 9 to 25 pin converter is included to suit PCs with a 25 pin serial converter.

RS422 Connections

Pin	Connection
4	Tx+ A
5	Tx- B
8	Rx+ A
9	Rx- B
1	Common

Using the Interface

The models are supplied with Cal NotePad as standard. This easy to use package is compatible with MS Windows 9x. A handbook for Cal NotePad can be found on the first installation disk in Adobe PDF format. If required a free Adobe PDF reader can be downloaded from, www.adobe.com.

CAL NOTEPAD

Cal Notepad can be used to log and display values from the Dry Blocks and an optional temperature indicator.

Minimum System Requirements

CNP requires Windows 95 / 98, a minimum of 5Mb of free hard drive space and free serial ports for the instruments to be connected.

Development

CNP was developed by Isothermal Technology using LabVIEW from National Instruments.

License

Use of the Cal NotePad software program "CNP" is as granted in this license agreement. In using the CNP

software the user "licensee" is agreeing to the terms of the license. You must read and understand the terms of this license before using CNP.

1, This license permits licensee to use CNP software on a single computer. The user may make copies for backup and archival purposes freely as long as the software is only ever in use on a single computer at any one time. Please enquire about multi-user licenses.

2, CNP is protected by international copyright laws and treaties. CNP must not be distributed to third parties.

3, CNP must not be reversed engineered, disassembled or de-compiled. Licensee may transfer the software to a third party provided that no copies or upgrades of CNP are retained.

4, It is the responsibility of the user to ensure the validity of all stored results and printed certificates. Isothermal Technology Ltd accept no responsibility for any errors caused by inappropriate use, incorrect set up or any other cause; including defects in the software.

5, Limited Warranty. Isothermal Technology warrants that CNP will perform substantially as

**MEDUSA 510/511 SERIES
HANDBOOK
ISSUE 10 - 11/05**

described in this manual for a period of 90 days from receipt. Any distribution media will under normal use be guaranteed for a period of 90 days.

NO OTHER WARRANTIES, EXCEPT AS STATED ABOVE. The software and documentation is provided "as is" without warranty of any kind and no other warranties (either expressed or implied) are made with regard to CNP. Isothermal Technology does not warrant, guarantee or make any representations regarding the use or results of the use of the software or documentation and does not warrant that the operation of CNP will be error free.

In no event will Isothermal Technology, its employees, agents or other associated people be liable for direct, indirect, incidental or consequential damages, expenses, lost profits, business interruption, lost business information or other damages arising out of the use or inability to use CNP. The license fee reflects this allocation of risk.

CNP is not designed for situations where the results can threaten or cause injury to humans.

Installing Cal NotePad

1. Insert CNP DISK 1 into the disk drive
2. Click on the START button on the task bar, select RUN, type A:\SETUP (Where A: is your drive letter) then click OK
3. Follow the prompts which will install the application and necessary LabVIEW run time support files.
4. Should you ever need to uninstall the software then use the Add/Remove Programs option from the Control Panel.

Starting Cal NotePad

From a Standard Installation:

Click the START button

Highlight PROGRAMS

Select
tech -
e c t
pad

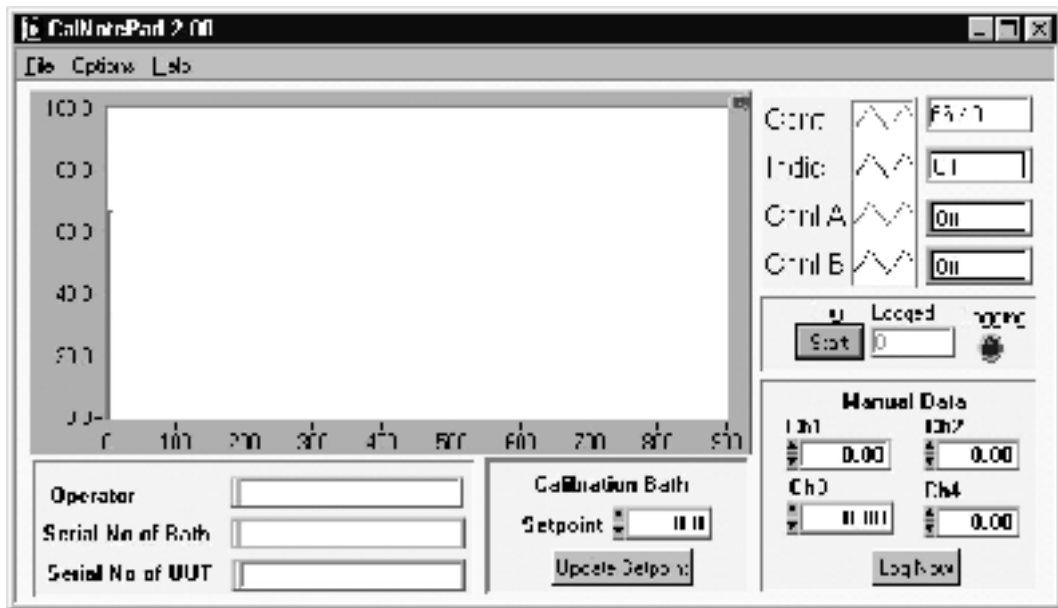

Iso
Sel
Cal

Protocol

The instruments use the "Eurotherm EI BiSynch Protocol"

If required, e.g. for writing custom software the technical details are available from our website at, www.isotech.co.uk/refer.html

Diagnostic alarms

These indicate that a fault exists in either the controller, indicator or the connected sensor.

Controller Error Messages

The instruments include powerful diagnostics and in the unlikely event of an internal failure, or a sensor error, one of the following error messages may be displayed.

Display shows	What it means	What to do about it
EE.Er	<i>Electrically Erasable Memory Error:</i> The value of an operator or configuration parameter has been corrupted	For Controller: Contact Isotech For Indicator: Check Config Against Data in Appendix
S.br	<i>Sensor Break:</i> Input sensor is unreliable or the input signal is out of range.	For Controller: Contact Isotech For Indicator: Check a sensor is connected. Check that only a PRT or a TC is Connected (Not both)
HW.Er	<i>Hardware error :</i> Indication that a module is of the wrong type, missing or faulty	Contact Isotech
LLLL	<i>Out of Display range, low reading</i>	For Controller: Contact Isotech For Indicator: Check Sensor and Connections
HHHH	<i>Out of Display range, high reading</i>	For Controller: Contact Isotech For Indicator: Check Sensor and Connections
Err1	<i>Error 1: ROM self-test fail</i>	Consult Isotech
Err2	<i>Error 2: RAM self-test fail</i>	Consult Isotech

Err3	<i>Error 3: Watchdog fail</i>	Consult Isotech
Err4	Error 4: Keyboard failure Stuck button, or a button was pressed during power up.	Switch the power off and then on without touching any of the controller buttons.
Err5	<i>Error 5: Input circuit failure</i>	Consult Isotech
Pwr.F	<i>Power failure.</i> The line voltage is too low	Check that the supply to the controller is within the rated limits

INITIAL TESTING

This unit was fully tested before despatch to you but please check its operation as outlined below.



After connecting the Medusa to the electricity supply, the temperature controller display will show the temperature of the block and the last set-point value. The controller and indicator both go through a self-test sequence first.

Change the set-point to 100°C and observe that the block temperature rises and settles to this value. Place a thermometer in the insert in the block and connect it to the suitably configured indicator. Confirm that the indicator agrees within $\pm 2^\circ\text{C}$ of the controller.

Your unit should have performed as described above and can now be used for calibration.

If any problems or faults arise during these tests please contact us or our agents for help and advice.

IMPORTANT NOTICE

The controller's function settings are preset and will not require adjustment.

MAINTENANCE

Maintenance is limit to keeping the apparatus and the calibration volume clean and free from debris.

There are no internal user serviceable parts.

Repair and maintenance must be carried out by Isothermal Technology Limited or an approved agent.

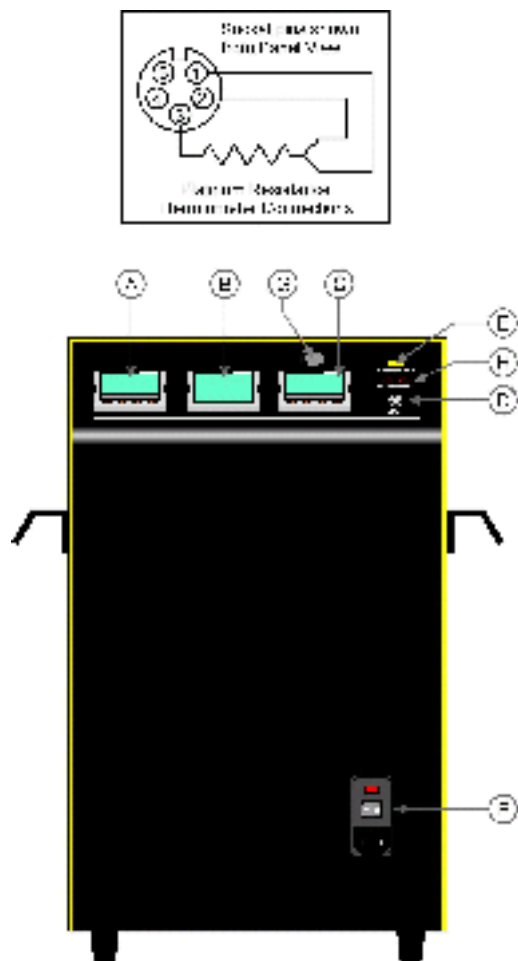

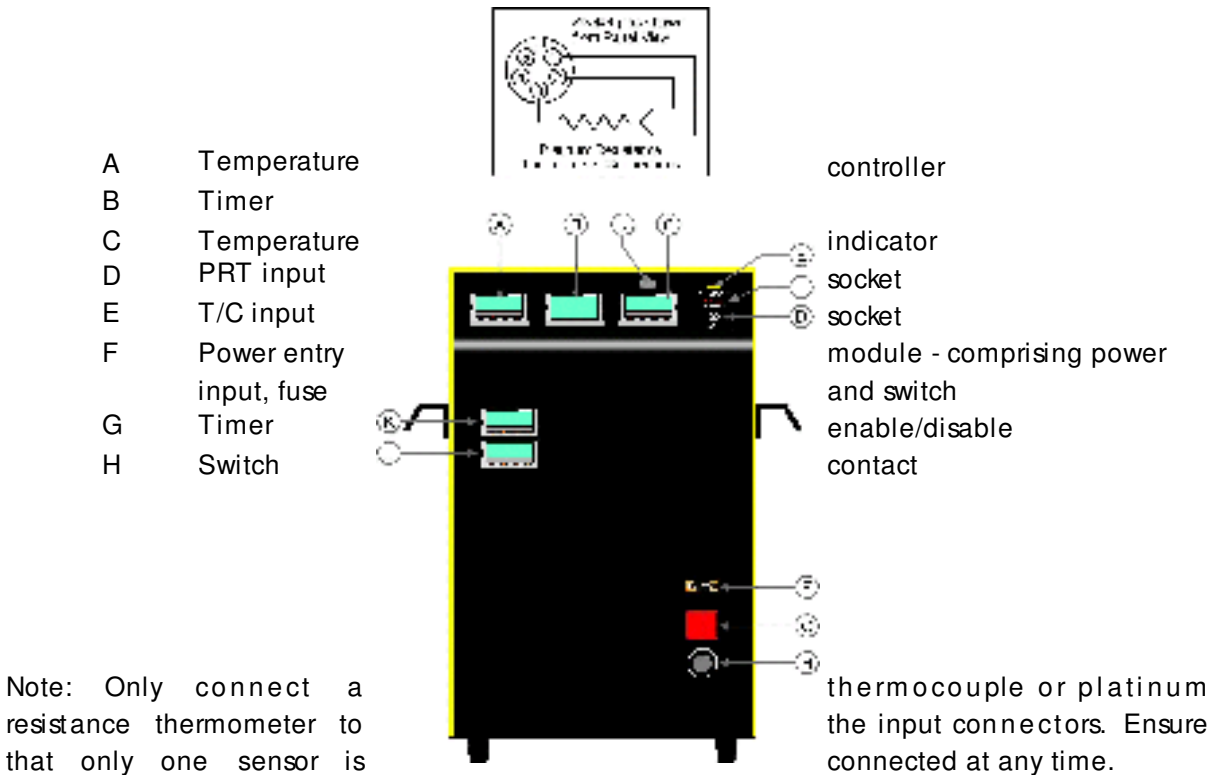

FIGURE 3
511 3 ZONE VERSION - 110V VERSION



A	Temperature controller
B	Timer
C	Temperature indicator
D	PRT input socket
E	T/C input socket
F	RS 422 comms socket
G	On/Off switch
H	Cable entry gland
I	Switch contact (thermostat)
J	Timer enable/disable
K	Top zone controller
L	Bottom zone controller

Note: Fuses and fuse carriers mounted internally. Accessed by removing the yellow cover. Factory set as: 110 Volt - Live - 20A Fuse, 0 Volt - Neutral - Link (can be exchanged for fuse if required)

APPENDIX 1

MEDUSA SERIES

TROUBLE SHOOTING

1. Unit fails to operate

Check fuse. If fuse blows repeatedly consult Isotech or local agent.

2. Indicator reads incorrectly

Two sensors connected simultaneously.

Indicator incorrectly configured - refer to 'Operating the Medusa' section.

3. Cannot establish PC Communications

For RS232 you must use the Isotech adaptor cable.

Ensure the addresses of the controller and indicator match those set in Cal Notepad.

Ensure each controller and indicator are set to a unique address.

Refer to 'Using the PC Interface' section and the Cal Notepad manual for further details.

APPENDIX 2

ACCESSORIES PARTS LIST FOR MEDUSA 510

Standard Dry Block Insert 510-06-01

Blank Insert 510-06-02

Adjustable Equalising Block	510-06-04
Blackbody Target Kit	510-06-05
Surface Sensor Calibrator Kit	580-06-06
Surface Sensor Probe	935-14-49
Surface Sensor Insert	510-02-02
Slim Gallium Melting Point Cell M 17401M	
Slim Indium Fixed Point Cell	M 17668M
Slim Tin Fixed Point Cell	M 17669M
Slim Lead Fixed Point Cell	M 17670M
Slim Zinc Fixed Point Cell	M 17671M

ACCESSORIES

Semi-Standard PRT	935-14-95/DB
Inconel Cell Basket	510-05-00
Storage Case	931-22-58

APPENDIX 2

ACCESSORIES PARTS LIST FOR MEDUSA 511

Adjustable Equalising Block	511-06-04
Blackbody Target Kit	511-06-05
Surface Sensor Calibrator Kit	511-06-06
Surface Sensor Probe	935-14-49
Surface Sensor Insert	510-02-02C
Slim Indium Fixed Point Cell	M 17668M
Slim Tin Fixed Point Cell	M 17669M
Slim Lead Fixed Point Cell	M 17670M
Slim Zinc Fixed Point Cell	M 17671M
Slim Aluminium Fixed Point Cell	M 17672M

ACCESSORIES

Semi-Standard PRT	935-14-95/DB
Inconel Cell Basket	511-05-01
Storage Case	931-22-58

APPENDIX 3

INDICATOR CONFIGURATION (Reference Only)

Config.INST

Name	Description	Value
unit	Instrument Units	°C (0)
dEcP	Decimal Places in Display	NN.NN
Ctrl	Control Type	PID (0)
Act	Control Action	REV (0)
COOL	Cooling Type	LIN (0)
PwrF	Power Feedback Enable	OFF (0)
Pdtr	Manual/Auto Transfer PD Control	NO (0)
FoP	Forced Output Enable	NO (0)
Sbrt	Sensor Break Type	SB.OP (0)
mGH	Process Value High Limit	670
mGL	Process Value Low Limit	0.00

Config.IP

Name	Description	Value
inPt	Linearisation Type	RTD
CJC	CJC Type	EXT
imP	Sensor break impedance	AUTO (1)

Config.CAL

Name	Description	Value
UCAL	User Calibration Enable	YES (1)
Pnt1	User Cal Point 1	0
Pnt5	User Cal Point 5	-99.00
OFS1	User Cal Offset 1	0.00
Pnt2	User Cal Point 2	-99
OFS2	User Cal Offset 2	0.00
Pnt3	User Cal Point 3	-99
OFS3	User Cal Offset 3	0.00
Pnt4	User Cal Point 4	-99.00
OFS4	User Cal Offset 4	0.00
OFS5	User Cal Offset 5	-99.00

Note: User Cal values are unique to each instrument. If available set values to those from

calibration certificate

Config.AL

Name	Description	Value
AL_1	Alarm 1 Type	OFF (0)
Ltch1	Alarm 1 Latching	NO (0)
AL_2	Alarm 2 Type	OFF (0)
Ltch2	Alarm 2 Latching	NO (0)
AL_3	Alarm 3 Type	OFF (0)
Ltch3	Alarm 3 Latching	NO (0)
AL_4	Alarm 4 Type	OFF (0)
Ltch4	Alarm 4 Latching	NO (0)

Config.HA

Name	Description	Value
id	Module Identity	CMS (7)
Func	Module Function	CMS (65)
bAud	Baud Rate	9600 (0)
PrtY	Comms Parity	NONE (0)
rES	Comms Resolution	FUL (0)

Config.1A

Name	Description	Value
id	Module Identity	LOG (3)
Func	Module function	NONE (0)
SEnS	Sense of Output	NOR (0)

Config.2A

Name	Description	Value
id	Module Identity	LOG (3)
Func	Module function	NONE (0)
SEnS	Sense of Output	NOR (0)

