

FLOWRATE INDICATOR / TOTALIZER

MS574

0210

0007

Electronic Register (ER)

METER MOUNT

REMOTE MOUNT



ER-M
GA012P

ER-RMA
ER-RMP
GB012P

Signal input flowmeter: NPN and Reed

 **macnaught**

CE



SAFETY INSTRUCTIONS

- Any responsibility is lapsed if the instructions and procedures as described in this manual are not followed.
- **LIFE SUPPORT APPLICATIONS:** The ER is not designed for use in life support appliances, devices, or systems where malfunction of the product can reasonably be expected to result in a personal injury. Customers using or selling these products for use in such applications do so at their own risk and agree to fully indemnify the manufacturer and supplier for any damages resulting from such improper use or sale.
- Electro static discharge does inflict irreparable damage to electronics! Before installing or opening the unit, the installer has to discharge himself by touching a well-grounded object.
- This unit must be installed in accordance with the EMC guidelines (Electro Magnetic Compatibility).

DISPOSAL - WEEE DIRECTIVE



- *The WEEE Directive requires the recycling of waste electrical and electronic equipment in the European Union.*
- *Whilst the WEEE Directive does not apply to some of Macnaught's products, we support its policy and ask you to be aware of how to dispose of this product.*
- *The crossed out wheeled bin symbol illustrated and found on our products signifies that this product should not be disposed of in general waste or landfill.*
- *Please contact your local dealer national distributor or Macnaught Technical Services for information on product disposal..*

SAFETY RULES AND PRECAUTIONARY MEASURES

- The manufacturer accepts no responsibility whatsoever if the following safety rules and precautions instructions and the procedures as described in this manual are not followed.
- Modifications of the ER implemented without preceding written consent from the manufacturer, will result in the immediate termination of product liability and warranty period.
- Installation, use, maintenance and servicing of this equipment must be carried out by authorized technicians.
- Check the mains voltage and information on the manufacturer's plate before installing the unit.
- Check all connections, settings and technical specifications of the various peripheral devices with the ER supplied.
- Open the casing only if all leads are free of potential.
- Never touch the electronic components (ESD sensitivity).
- Never expose the system to heavier conditions than allowed according to the casing classification (see manufacture's plate and chapter 4.2.).
- If the operator detects errors or dangers, or disagrees with the safety precautions taken, then inform the owner or principal responsible.
- The local labor and safety laws and regulations must be adhered to.

ABOUT THE OPERATION MANUAL

This operation manual is divided into two main sections:

- The daily use of the unit is described in chapter 2 "Operation". These instructions are meant for users.
- The following chapters and appendices are exclusively meant for electricians/technicians. These provide a detailed description of all software settings and hardware installation guidance.

This operation manual describes the standard unit as well as most of the options available. For additional information, please contact your supplier.

A hazardous situation may occur if the ER is not used for the purpose it was designed for or is used incorrectly. Please carefully note the information in this operating manual indicated by the pictograms:



A "**warning**" indicates actions or procedures which, if not performed correctly, may lead to personal injury, a safety hazard or damage of the ER or connected instruments.



Caution !

A "**caution**" indicates actions or procedures which, if not performed correctly, may lead to personal injury or incorrect functioning of the ER or connected instruments.



Note !

A "**note**" indicates actions or procedures which, if not performed correctly, may indirectly affect operation or may lead to an instrument response which is not planned.

Hardware version	:	FB03.03.xx
Software version	:	MCN0121
Manual	:	MS574 0210 0007
© Copyright 2013	:	Macnaught – All rights reserved

Information in this manual is subject to change without prior notice. The manufacturer is not responsible for mistakes in this material or for incidental damage caused as a direct or indirect result of the delivery, performance or use of this material.

© All rights reserved. No parts of this publication may be reproduced or used in any form or by any means without written permission of your supplier.

CONTENTS MANUAL

Safety instructions	2
Disposal - WEEE Directive	2
Safety rules and precautionary measures	2
About the operation manual	3
Contents manual.....	4
1. Introduction	5
1.1. System description of the ER.....	5
2. Operational	6
2.1. General	6
2.2. Control panel.....	6
2.3. Operator information and functions	7
3. Configuration	8
3.1. Introduction	8
3.2. Programming SETUP-level.....	8
3.2.1. General	8
3.2.2. Overview functions SETUP level	11
3.2.3. Explanation of SETUP-functions.....	12
1 - Total.....	12
2 - Flowrate	13
3 - Display	14
4 - Power management	14
5 - Flowmeter	15
6 - Others	15
4. Installation	16
4.1. General directions	16
4.2. Installation / surrounding conditions	16
4.3. Dimensions- Enclosure	17
4.4. Installing the hardware.....	19
4.4.1. Introduction	19
4.4.2. Terminal connectors with power supply.....	19
5. Maintenance	22
5.1. General directions	22
5.2. Repair.....	22
Appendix A: Technical specification	23
Appendix B: Problem solving	25
Index of this manual.....	26
List of figures in this manual.....	27
List of configuration settings.....	28

1. INTRODUCTION

1.1. SYSTEM DESCRIPTION OF THE ER

Functions and features

The flowrate / totalizer model ER is a microprocessor driven instrument designed to display flowrate, total and accumulated total.

This product has been designed with a focus on:

- ultra-low power consumption to allow long-life battery powered applications (type PB / PC),
- several mounting possibilities with Meter mount, GRP or aluminum enclosures for industrial surroundings,
- ability to process two types of flowmeter signals, NPN and Reed.

Flowmeter input

This manual describes the unit with a pulse type input from the flowmeter "-P version".

One flowmeter with a NPN or Reed switch output can be connected to the ER. To power the sensor, several options are available.

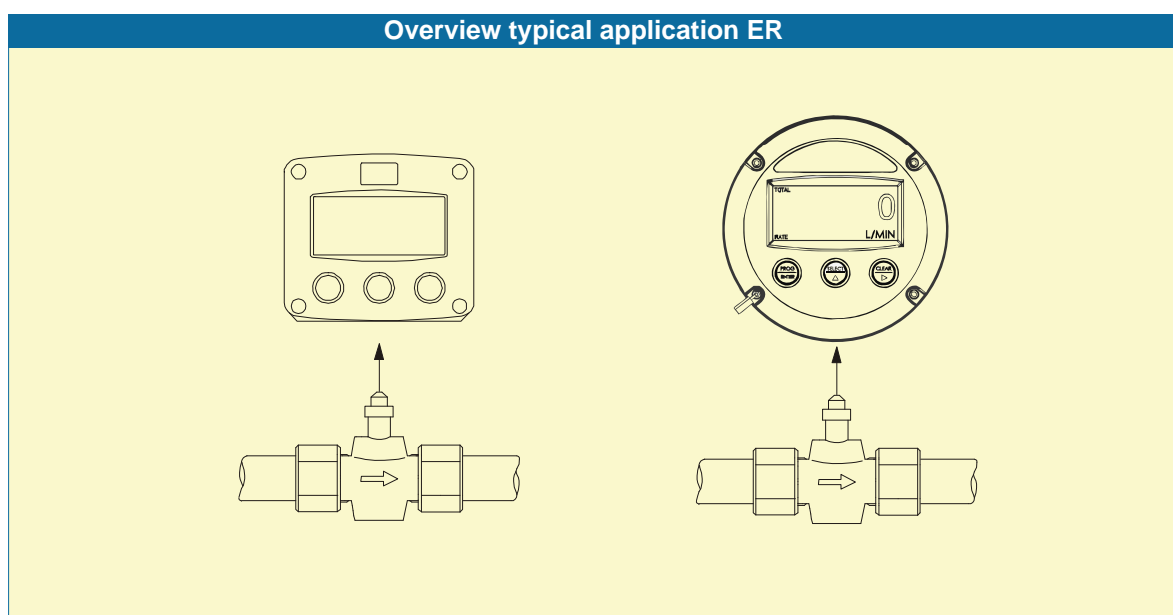

Fig. 1: Typical application for the ER

Configuration of the unit

The ER has been designed to be implemented in many types of applications. For that reason, a SETUP-level is available to configure your ER according to your specific requirements.

It includes several important features, such as K-factors, measurement units, signal selection etc. All settings are stored in EEPROM memory and will not be lost in the event of power failure. To extend the battery-life time, please use of the power-management functions as described in chapter 3.2.3.

Display information

The unit has a large transfective LCD with all kinds of symbols and digits to display measuring units, status information, trend-indication and key-word messages.

Flowrate and totals can be displayed either with the small 8mm digits or with the 17mm digits.

A backup of the total and accumulated total in EEPROM memory is made every minute.

Options

The following options are available: power- and sensor-supply options, panel-mount, wall-mount, meter mount and weather-proof enclosures and LED backlight.

2. OPERATIONAL

2.1. GENERAL



- *The ER may only be operated by personnel who are authorized and trained by the operator of the facility. All instructions in this manual are to be observed.*
- *Take careful notice of the " Safety rules, instructions and precautionary measures " in the front of this manual.*

This chapter describes the daily use of the ER. This instruction is meant for users / operators.

2.2. CONTROL PANEL

The following keys are available:



Fig. 2: Control Panel.

Functions of the keys



This key is used to program and save new values or settings.
It is also used to gain access to SETUP-level; please read chapter 3.



This key is used to SELECT accumulated total.
The arrow-key ▲ is used to increase a value after PROG has been pressed or to configure the unit; please read chapter 3.



Press this key twice to CLEAR the value for total.
The arrow-key ► is used to select a digit after PROG has been pressed or to configure the unit; please read chapter 3.

2.3. OPERATOR INFORMATION AND FUNCTIONS

In general, the ER will always function at Operator level. The information displayed is dependent upon the SETUP-settings. The signal from the connected sensor is processed by the ER in the background, whichever screen refresh rate setting is chosen. After pressing a key, the display will be updated very quickly during a 30 second period, after which it will slow-down again.



Fig. 3: Example of display information during process.

For the Operator, the following functions are available:

- **Display flowrate / total or flowrate**

This is the main display information of the ER. After selecting any other information, it will always return to this main display automatically.

Total is displayed on the upper-line of the display and flowrate on the bottom line.

It is possible to display flowrate only with the large 17mm digits; in this instance press the SELECT-key to read the total.

When "-----" is shown, then the flowrate value is too high to be displayed. The arrows \blacktriangleleft \blacktriangleright indicate the increase/decrease of the flowrate trend.

- **Clear total**

The value for total can be re-initialized. To do so, press CLEAR twice. After pressing CLEAR once, the flashing text "PUSH CLEAR" is displayed. To avoid re-initialization at this stage, press another key than CLEAR or wait for 20 seconds.

Re-initialization of total DOES NOT influence the accumulated total.

- **Display accumulated total**

When the SELECT-key is pressed, total and accumulated total are displayed. The accumulated total cannot be re-initialized. The value will count up to 99,999,999,999. The unit and number of decimals are displayed according to the configuration settings for total.

- **Low-battery alarm**

When the battery voltage drops, it must be replaced. At first "low-battery" will flash, but as soon as it is displayed continuously, the battery MUST be replaced shortly after!

Only original batteries supplied by the manufacturer may be used, else the guarantee and liability will be terminated. The remaining lifetime after the first moment of indication is generally several days up to some weeks.



Fig. 4: Example of low-battery alarm.

- **Alarm 01-03**

When "alarm" is displayed, please consult Appendix B: problem solving.

3. CONFIGURATION

3.1. INTRODUCTION

This and the following chapters are exclusively meant for electricians and non-operators. In these, an extensive description of all software settings and hardware connections are provided.



- *Mounting, electrical installation, start-up and maintenance of the instrument may only be carried out by trained personnel authorized by the operator of the facility. Personnel must read and understand this Operating Manual before carrying out its instructions.*
- *The ER may only be operated by personnel who are authorized and trained by the operator of the facility. All instructions in this manual are to be observed.*
- *Ensure that the measuring system is correctly wired up according to the wiring diagrams. The housing may only be opened by trained personnel.*
- *Take careful notice of the " Safety rules, instructions and precautionary measures " in the front of this manual.*

3.2. PROGRAMMING SETUP-LEVEL

3.2.1. GENERAL

Configuration of the ER is done at SETUP-level. SETUP-level is reached by pressing the PROG/ENTER key for 7 seconds; at which time, both arrows \blacktriangle will be displayed. In order to return to the operator level, PROG will have to be pressed for three seconds. Alternatively, if no keys are pressed for 2 minutes, the unit will exit SETUP automatically. SETUP can be reached at all times while the ER remains fully operational.



Note: A pass code may be required to enter SETUP. Without this pass code access to SETUP is denied.

To enter SETUP-level:

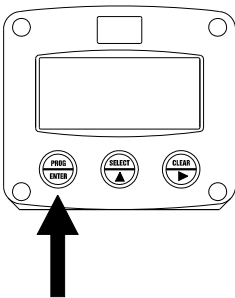

Press  for 7 seconds

Matrix structure SETUP-level:

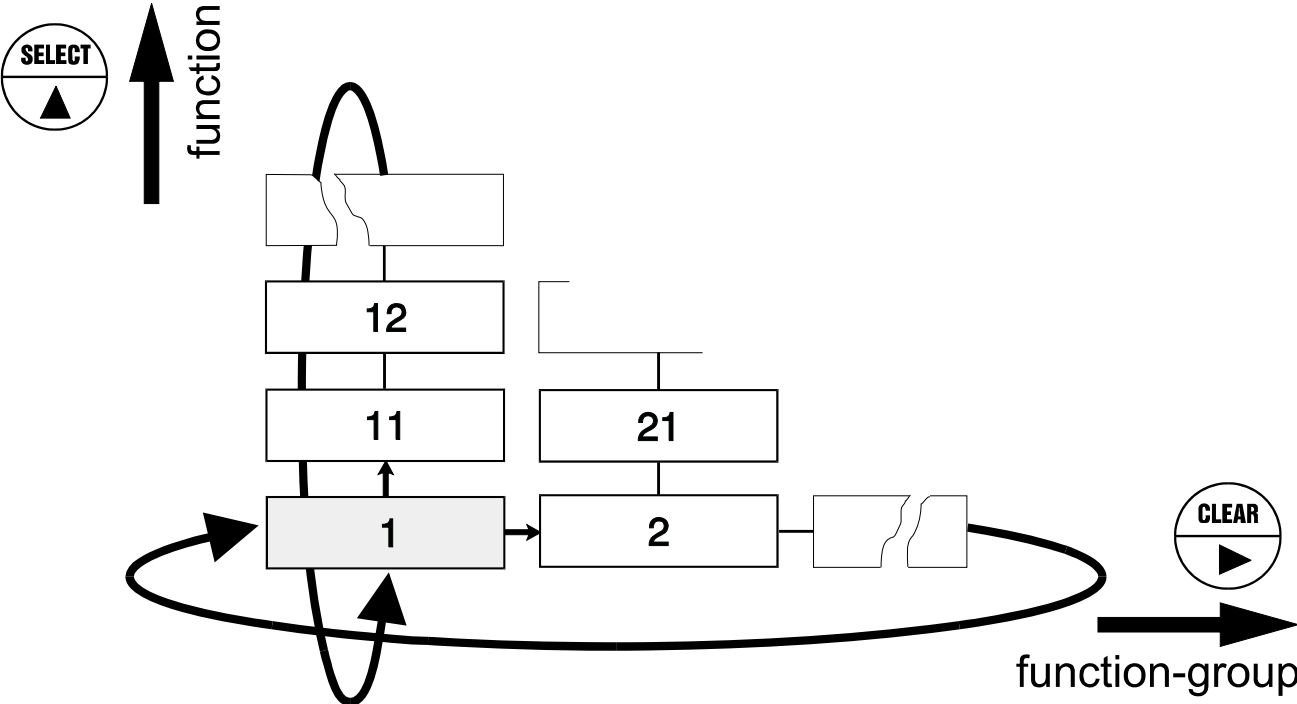

SCROLLING THROUGH SETUP-LEVEL

Selection of function-group and function:
SETUP is divided into several function groups and functions.

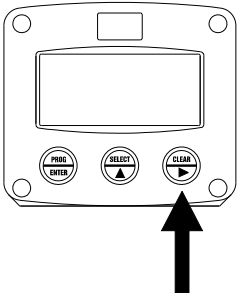

Select function-group with

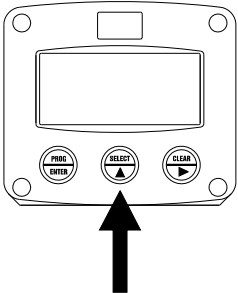

Select function with









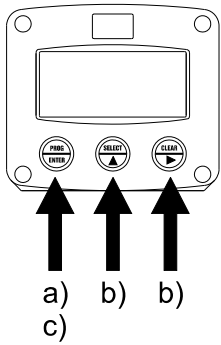

Each function has a unique number, which is displayed below the word "SETUP" at the bottom of the display. The number is a combination of two figures. The first figure indicates the function-group and the second figure the sub-function. Additionally, each function is expressed with a keyword.



After selecting a sub-function, the next main function is selected by scrolling through all "active" sub-functions (e.g. 1▲, 11▲, 12▲, 13▲, 14▲, 1▶, 2▶, 3▲, 31 etc.). The "CLEAR" button can be used to jump a step back if you missed the desired function.

To change or select a value:



- a) press  briefly; **PROGRAM** will start flash
- b) select or enter value with  and / or 
- c) press  to confirm the value / selection.

To change a value, use  to select the digits and  to increase that value. If the new value is invalid, the increase sign  or decrease-sign  will be displayed while you are programming.

To select a setting,  is used to select in one direction and  can be used to select in the other direction.

When data is altered but ENTER is not pressed, then the alteration can still be cancelled by waiting for 20 seconds or by pressing ENTER for three seconds: the PROG-procedure will be left automatically and the former value reinstated.



Note: alterations will only be set after ENTER has been pressed!

To return to OPERATOR-level:

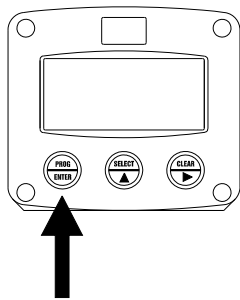

Press  for 3 seconds

In order to return to the operator level, PROG will have to be pressed for three seconds. Also, when no keys are pressed for 2 minutes, SETUP will be left automatically.

3.2.2. OVERVIEW FUNCTIONS SETUP LEVEL

SETUP FUNCTIONS AND VARIABLES			
1	TOTAL		
	11	UNIT	L - m3 - kg - lb - GAL - USGAL - bbl - no unit
	12	DECIMALS	0 - 1 - 2 - 3 (Ref: displayed value)
	13	K-FACTOR:	0.000010 - 9,999,999
	14	DECIMALS K-FACTOR	0 - 6
2	FLOWRATE		
	21	UNIT	mL - L - m3 - mg - g - kg - ton - GAL - bbl - lb - cf - REV - no unit - scf - Nm3 - NL - P
	22	TIME UNIT	sec - min - hour - day
	23	DECIMALS	0 - 1 - 2 - 3 (Ref: displayed value)
	24	K-FACTOR	0.000010 - 9,999,999
	25	DECIMALS K-FACTOR	0 - 6
	26	CALCULATION	per 1 - 255 pulses
	27	CUT-OFF	0.1 - 999.9 seconds
3	DISPLAY		
	31	FUNCTION	total - flowrate
	32	BACKLIGHT (optional)	off - green - amber
	33	BL. BRIGHTNESS	1 - 5
4	POWER MANAGEMENT		
	41	LCD UPDATE	fast - 1 sec - 3 sec - 15 sec - 30 sec - off
	42	BATTERY MODE	operational - shelf
5	FLOWMETER		
	51	SIGNAL	npn - npn_lp - reed - reed_lp
6	OTHERS		
	61	TYPE / MODEL	ER
	62	SOFTWARE VERSION	MCN0121
	63	SERIAL NO.	xxxxxxx
	64	PASS CODE	0000 - 9999
	65	TAGNUMBER	0000000 - 9999999

3.2.3. EXPLANATION OF SETUP-FUNCTIONS

1 - TOTAL	
MEASUREMENT UNIT 11	<p>SETUP - 11 determines the measurement unit for total and accumulated total. The following units can be selected:</p> <p style="text-align: center;">L - m3 - kg - lb. - GAL - USGAL - bbl - _ (no unit).</p> <p>Alteration of the measurement unit will have consequences for operator and SETUP-level values. Please note that the K-factor has to be adapted as well; the calculation is not done automatically.</p>
DECIMALS 12	<p>The decimal point determines for total and accumulated total the number of digits following the decimal point. The following can be selected:</p> <p style="text-align: center;">000000 - 111111.1 - 22222.22 - 3333.333</p>
K-FACTOR 13	<p>With the K-factor, the flowmeter pulse signals are converted to a quantity. The K-factor is based on the number of pulses generated by the flowmeter per selected measurement unit (SETUP 11), for example per cubic meter. The more accurate the K-factor, the more accurate the functioning of the system will be.</p> <p>Example 1: Calculating the K-factor. <i>Let us assume that the flowmeter generates 2.4813 pulses per liter and the selected unit is "cubic meters / m3". A cubic meter consists of 1000 parts of one liter which implies 2,481.3 pulses per m3. So, the K-factor is 2,481.3. Enter for SETUP - 13: "2481300" and for SETUP - 14 - decimals K-factor "3".</i></p> <p>Example 2: Calculating the K-factor. <i>Let us assume that the flowmeter generates 6.5231 pulses per gallon and the selected measurement unit is gallons. So, the K-Factor is 6.5231. Enter for SETUP - 13: "6523100" and for SETUP - 14 decimals K-factor "6".</i></p>
DECIMALS K-FACTOR 14	<p>This setting determines the number of decimals for the K-factor entered. (SETUP 13). The following can be selected:</p> <p style="text-align: center;">0 - 1 - 2 - 3 - 4 - 5 - 6</p> <p>Please note that this setting influences the accuracy of the K-factor indirectly. (i.e. the position of the decimal point and thus the value given) This setting has NO influence on the displayed number of digits for total (SETUP 12)!</p>

2 - FLOWRATE

The settings for total and flowrate are entirely separate. In this way, different units of measurement can be used for each e.g. cubic meters for total and liters for flowrate.
The display update time for flowrate is one second or more.

MEASUREMENT UNIT 21	<p>SETUP - 21 determines the measurement unit for flowrate. The following units can be selected:</p> <p style="text-align: center;">mL - L - m3 - mg - g - kg - ton - GAL - bbl - lb - cf - REV - no unit - scf - Nm3 - NL - P.</p> <p>Alteration of the measurement unit will have consequences for operator and SETUP-level values. Please note that the K-factor has to be adapted as well; the calculation is not done automatically.</p>
TIME UNIT 22	The flowrate can be calculated per second (SEC), minute (MIN), hour (HR) or day (DAY).
DECIMALS 23	<p>This setting determines for flowrate the number of digits following the decimal point. The following can be selected:</p> <p style="text-align: center;">00000 - 1111.1 - 2222.22 - 3333.333</p>
K-FACTOR 24	<p>With the K-factor, the flowmeter pulse signals are converted to a flowrate. The K-factor is based on the number of pulses generated by the flowmeter per selected measurement unit (SETUP 21), for example per liter. The more accurate the K-factor, the more accurate the functioning of the system will be. For examples read SETUP 13.</p>
DECIMALS K-FACTOR 25	<p>This setting determines the number of decimals for the K-factor (SETUP 24). The following can be selected:</p> <p style="text-align: center;">0 - 1 - 2 - 3 - 4 - 5 - 6</p> <p>Please note that this SETUP - influences the accuracy of the K-factor indirectly. This setting has NO influence on the displayed number of digits for "flowrate" (SETUP 23)!</p>
CALCULATION 26	<p>The flowrate is calculated by measuring the time between a number of pulses, for example 10 pulses. The more pulses the more accurate the flowrate will be. The maximum value is 255 pulses.</p> <p>Note: <i>the lower the number of pulses, the higher the power consumption of the unit will be (important for battery powered applications).</i></p> <p>Note: <i>for low frequency applications (below 10Hz): do not program more than 10 pulses else the update time will be very slow.</i></p> <p>Note: <i>for high frequency application (above 1kHz) do program a value of 100 or more pulses.</i></p>
CUT-OFF TIME 27	<p>With this setting, you determine a minimum flow requirement threshold, if during this time less than XXX-pulses (SETUP 26) are generated, the flowrate will be displayed as zero. The cut-off time has to be entered in seconds - maximum time is 999 seconds (about 15 minutes).</p>



Note !

3 - DISPLAY	
FUNCTION 31	The large 17mm digits can be set to display total or flowrate. When "total" is selected, both total and flowrate are displayed simultaneously. When "flowrate" is selected, only flowrate will be displayed with it's measuring unit while total will be displayed after pressing SELECT.
The functions below will only effect the optional LED-backlight.	
BACKLIGHT (OPTION) 32	If a LED backlight has been supplied, the color can be selected. Following selections are available: OFF - GREEN - AMBER
BRIGHTNESS (OPTION) 33	The density of the backlight can be set in following range: 1 - 5 One is minimum and five is maximum brightness.

4 - POWER MANAGEMENT	
When used with the internal battery option, the user can expect reliable measurement over a long period of time. The ER has several smart power management functions to extend the battery life time significantly. Two of these functions can be set:	
LCD NEW 41	The calculation of the display-information influences the power consumption significantly. When the application does not require a fast display update, it is strongly advised to select a slow refresh rate. Please understand that NO information will be lost; every pulse will be counted and the output signal will be generated in the normal way. The following can be selected: Fast - 1 sec - 3 sec - 15 sec - 30 sec - off. Example battery life-time: <i>life-time with a coil pick-up, 1kHz. pulses and FAST update: about 2 years.</i> <i>life-time with a coil pick-up, 1kHz. pulses and 1 sec update: about 5 years.</i> Note: after a button has been pressed by the operator - the display refresh rate will always switch to FAST for 30 seconds. When "OFF" is selected, the display will be switched off after 30 seconds and will be switched on as soon as a button has been pressed.
BATTERY-MODE 42	The unit has two modes: operational or shelf. After "shelf" has been selected, the unit can be stored for several years; it will not process the sensor signal; the display is switched off but all settings and totals are stored. In this mode, power consumption is extremely low. To wake up the unit again, press the SELECT-key twice.



Note !

5 - FLOWMETER

SIGNAL 51	The ER is able to handle several types of input signal. The type of flowmeter pickup / signal is selected with SETUP 51. Read also par. 4.4.2. or 4.4.3 - flowmeter input terminals.			
TYPE OF SIGNAL	EXPLANATION	RESISTANCE	FREQ. / MV	REMARK
NPN	NPN input	100kOhm pull-up	6 kHz.	(open collector)
NPN - LP	NPN input with low pass filter	100kOhm pull-up	1.2 kHz.	(open collector) less sensitive
REED	Reed-switch input	1mOhm pull-up	600 Hz.	
REED - LP	Reed-switch input with low pass filter	1mOhm pull-up	120 Hz.	Less sensitive

6 - OTHERS

TYPE OF MODEL 61	For support and maintenance it is important to have information about the characteristics of the ER. Your supplier will ask for this information in the case of a serious breakdown or to assess the suitability of your model for upgrade considerations.
VERSION SOFTWARE 62	For support and maintenance it is important to have information about the characteristics of the ER. Your supplier will ask for this information in the case of a serious breakdown or to assess the suitability of your model for upgrade considerations.
SERIAL NUMBER 63	For support and maintenance it is important to have information about the characteristics of the ER. Your supplier will ask for this information in the case of a serious breakdown or to assess the suitability of your model for upgrade considerations.
PASS CODE 64	All SETUP-values can be pass code protected. This protection is disabled with value 0000 (zero). Up to and including 4 digits can be programmed, for example 1234.
TAGNUMBER 65	For identification of the unit and communication purposes, a unique tag number of maximum 7 digits can be entered.

4. INSTALLATION

4.1. GENERAL DIRECTIONS



- *Mounting, electrical installation, start-up and maintenance of this instrument may only be carried out by trained personnel authorized by the operator of the facility. Personnel must read and understand this Operating Manual before carrying out its instructions.*
- *The ER may only be operated by personnel who are authorized and trained by the operator of the facility. All instructions in this manual are to be observed.*
- *Ensure that the measuring system is correctly wired up according to the wiring diagrams. Protection against accidental contact is no longer assured when the housing cover is removed or the panel cabinet has been opened (danger from electrical shock). The housing may only be opened by trained personnel.*
- *Take careful notice of the " Safety rules, instructions and precautionary measures " at the front of this manual.*

4.2. INSTALLATION / SURROUNDING CONDITIONS

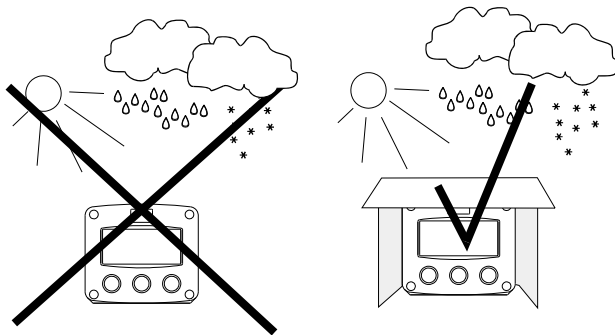

Take the relevant IP classification of the casing into account (see manufactures plate). Even an IP67 (NEMA 4X) casing should NEVER be exposed to strongly varying (weather) conditions.

When panel-mounted, the unit is IP65 (NEMA 4X)!

When used in very cold surroundings or varying climatic conditions, take the necessary precautions against moisture by placing a dry sachet of silica gel, for example, inside the instrument case.

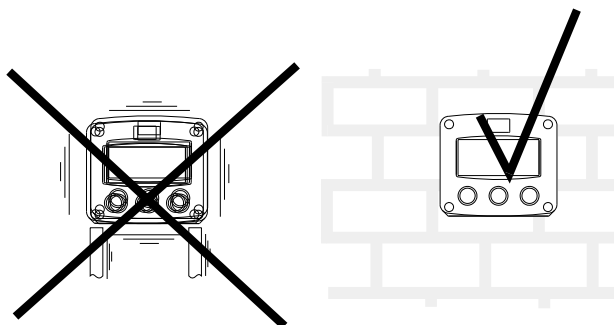

Mount the ER on a solid structure to avoid vibrations.

4.3. DIMENSIONS- ENCLOSURE

Aluminum enclosures ER-RMA:

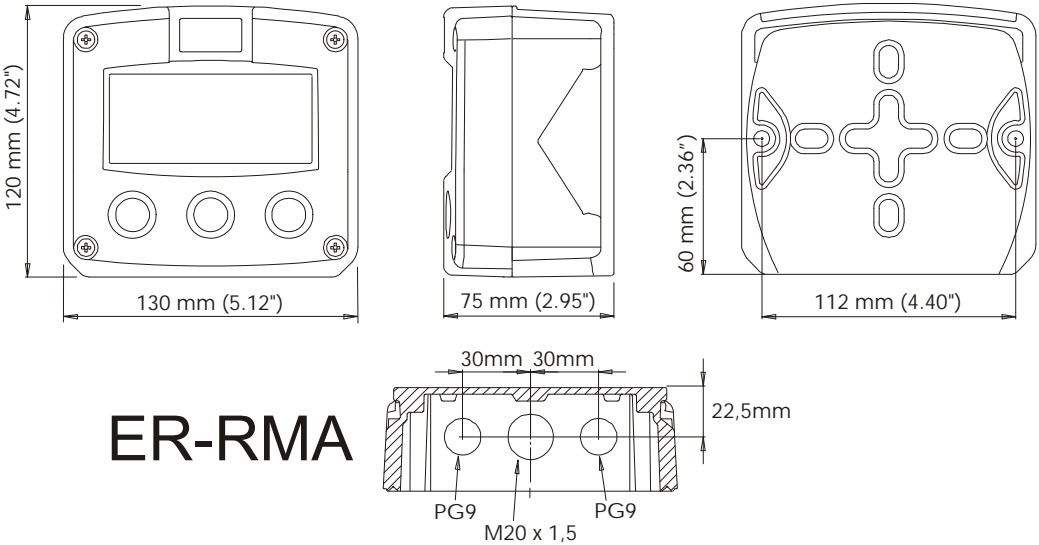

PANEL MOUNT (option)

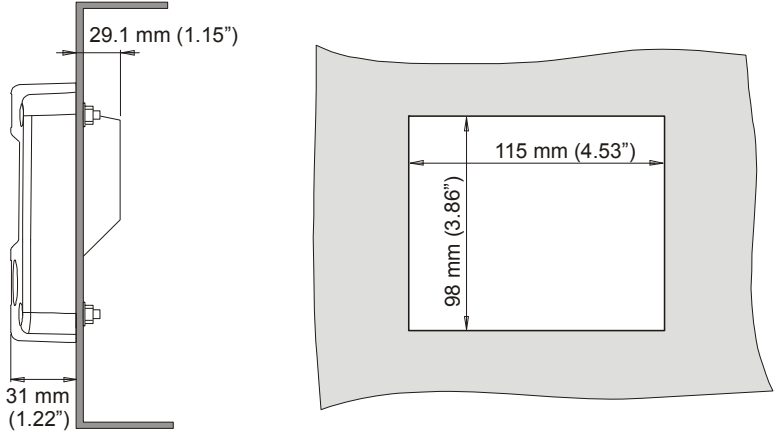

Fig. 5: Dimensions Aluminum enclosures.

Plastic (GRP) enclosures ER-RMP:

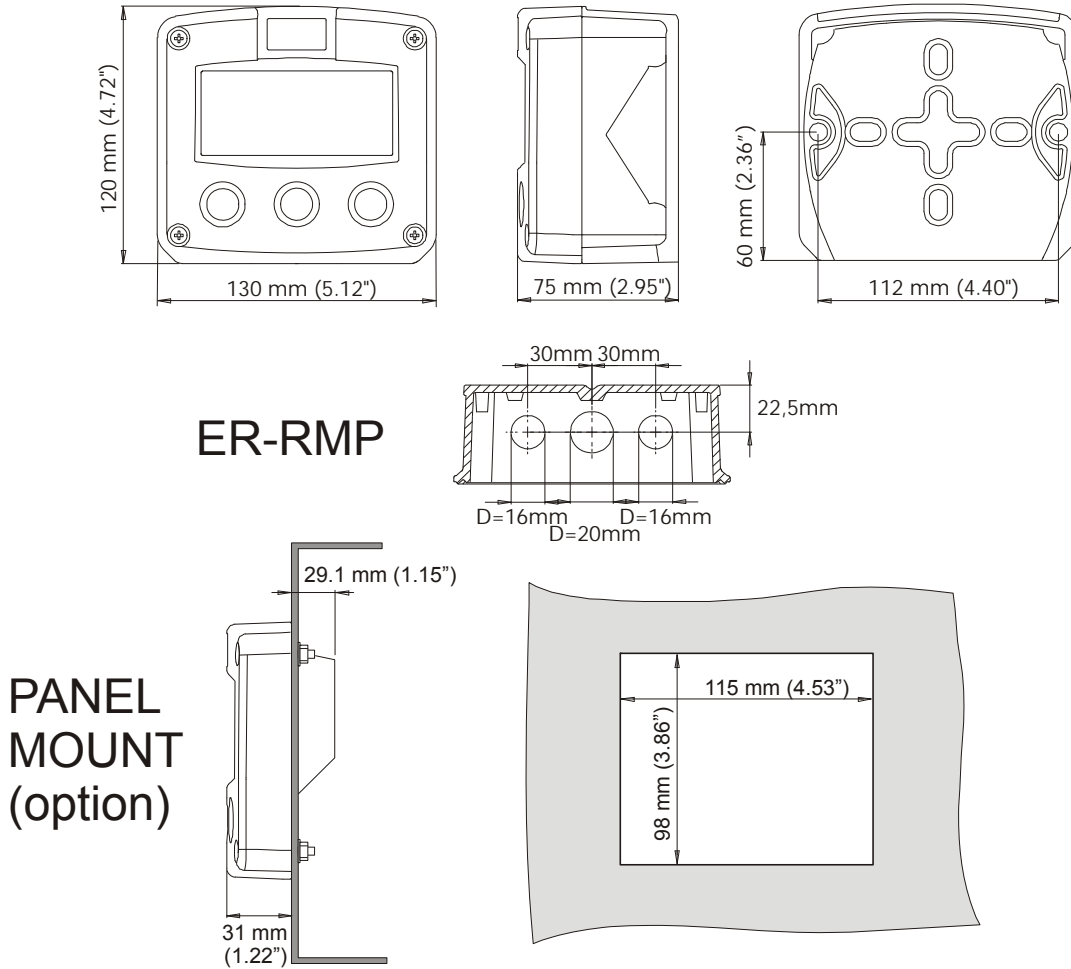

Fig. 6: Dimensions GRP enclosures.

Meter Mount enclosures ER-M:

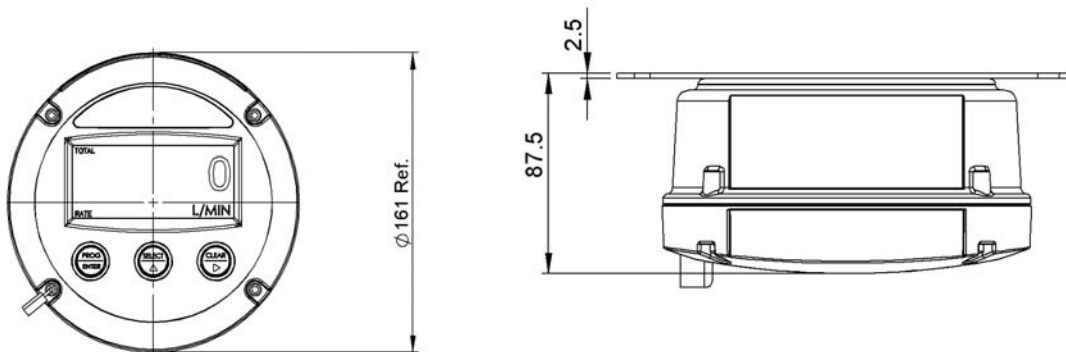

Fig. 6A: Dimensions ER-M series Meter mount enclosures.

4.4. INSTALLING THE HARDWARE

4.4.1. INTRODUCTION



- *Electro static discharge does inflict irreparable damage to electronics! Before installing or opening the unit, the installer has to discharge himself by touching a well-grounded object.*



- *This unit must be installed in accordance with the EMC guidelines (Electro Magnetic Compatibility).*

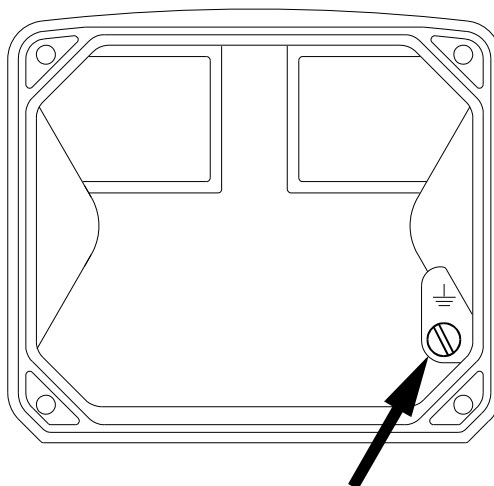

Fig. 7: Grounding aluminum enclosure

FOR INSTALLATION, PAY EMPHATIC ATTENTION TO:

- Separate cable glands with effective IP67 (NEMA4X) seals for all wires.
- Unused cable entries: ensure that you fit IP67 (NEMA4X) plugs to maintain rating.
- A reliable ground connection for both the sensor, and if applicable, for the metal casing. (above)
- An effective screened cable for the input signal, and grounding of it's screen to the "⊥" terminal or at the sensor itself, whichever is appropriate to the application.

4.4.2. TERMINAL CONNECTORS WITH POWER SUPPLY

The following terminal connectors are available:

SENSOR SIGNAL PULSE INPUT			POWER SUPPLY UNIT			POWER SUPPLY BACKLIGHT			
1	2	3	4	5	6		9	10	
⊥	SIGNAL	+↓	⊥	+↑	+↓		⊥	+↑	

Fig. 8: Overview of terminal connectors ER

SENSOR SUPPLY

Terminal 3: sensor supply 1.2V, 3.2V

Terminal 3 provides a limited supply voltage of 3.2 V DC (coil signals 1.2V) for the signal output of the flowmeter.



Note: This voltage MAY NOT be used to power the flowmeters electronics, converters etc, as it will not provide adequate sustained power ! All energy used by the flowmeters pick-up will directly influence the battery life-time. It is strongly advised to use a "zero power" pickup such as a coil or reed-switch when operating without external power. It is possible to use some low power NPN or PNP output signals, but the battery life time will be significantly reduced (consult your distributor).

Terminal 4-5: POWER SUPPLY UNIT

To power the unit an internal battery can be used and / or an external DC power supply of 16-30V DC.

Connect the "-" to terminal 4 and the "+" to terminal 5. When power is applied to these terminals, the optional internal battery will be disabled / enabled automatically to extend the battery life time.

Terminal 6: Power supply: 8.2V sensor supply

With this option, a limited power supply for the sensor is available, for example to power a Namur sensor. It offers 8.2V DC (max. 5mA).

REMARKS: TERMINAL CONNECTORS

TERMINALS 1-3; FLOWMETER INPUT

Two types of flowmeter signals can be connected to the unit: NPN and Reed switch. The screen of the signal wire must be connected to the common ground terminal

The input signal type has to be selected with the correct SETUP-function (read par. 3.2.3.)

Pulse-signal NPN / NPN-LP input

The ER is suitable for use with flowmeters which have a NPN output signal. For reliable pulse detection, the pulse amplitude has to go below 1.2V. Signal setting NPN-LP employs a low-pass signal noise filter, which limits the maximum input frequency - read par. 3.2.3.

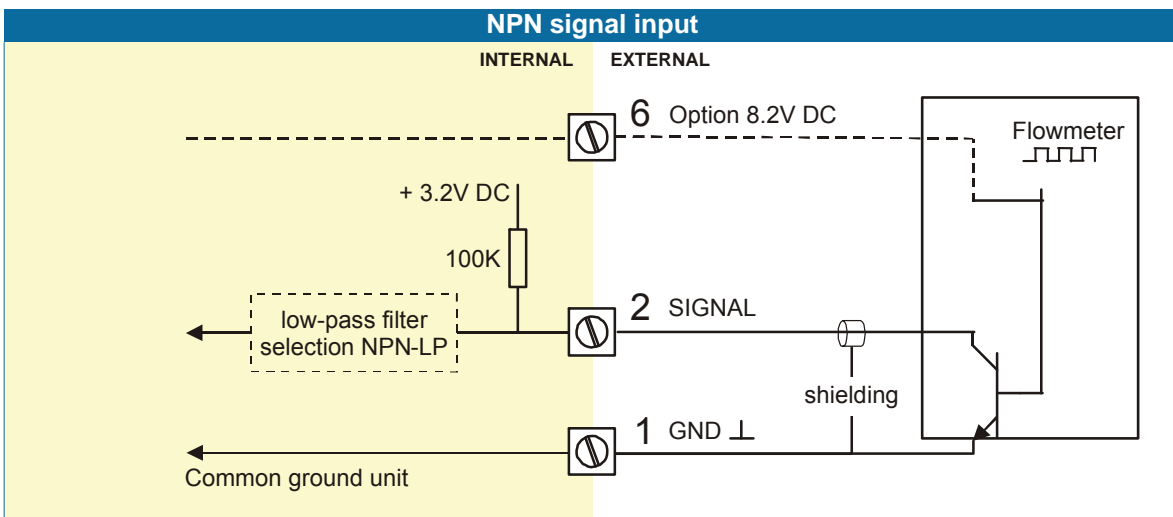

Reed-switch input

The ER is suitable for use with flowmeters which have a Reed-switch. To avoid pulse bounce from the Reed-switch, it is advised to select REED LP - low-pass filter (read par. 3.2.3.)

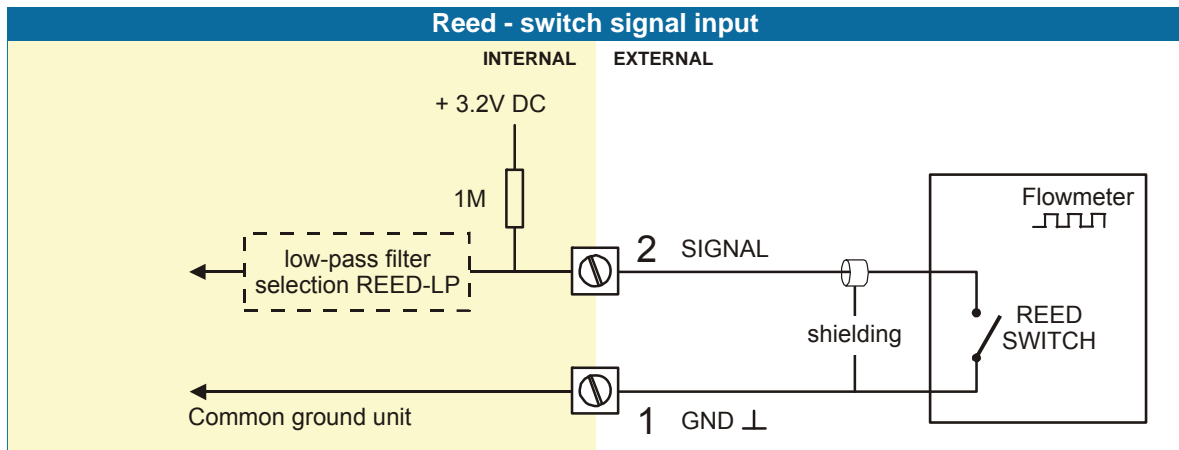

Terminal 9-10: Power supply Backlight

To power the backlight, a voltage in the range 20-30V DC has to be connected. Maximum current 30mA. Connect the "-" to terminal 9 and the "+" to terminal 10.

5. MAINTENANCE

5.1. GENERAL DIRECTIONS



- *Mounting, electrical installation, start-up and maintenance of the instrument may only be carried out by trained personnel authorized by the operator of the facility. Personnel must read and understand this Operating Manual before carrying out its instructions.*
- *The ER may only be operated by personnel who are authorized and trained by the operator of the facility. All instructions in this manual are to be observed.*
- *Ensure that the measuring system is correctly wired up according to the wiring diagrams. Protection against accidental contact is no longer assured when the housing cover is removed or the panel cabinet has been opened (danger from electrical shock). The housing may only be opened by trained personnel.*
- *Take careful notice of the " Safety rules, instructions and precautionary measures " in the front of this manual.*

The ER does not require special maintenance unless it is used in low-temperature applications or surroundings with high humidity (above 90% annual mean). It is the users responsibility to take all precautions to dehumidify the internal atmosphere of the ER in such a way that no condensation will occur, for example by placing dry silica-gel sachet in the casing just before closing it. Furthermore, it is required to replace or dry the silica gel periodically as advised by the silica gel supplier.

Battery life-time:

It is influenced by several issues :

- Input frequency: the higher the frequency, the shorter the battery life-time.
- Flowrate calculation: the lower number of pulses (SETUP 26) the shorter the battery life-time.
- Display update: fast display update uses significantly more power.
- Low temperatures; the available power will be less due to battery chemistry.



Note: *It is strongly advised to use only necessary functions.*

Check periodically:

- The condition of the casing, cable glands and front panel.
- The input/output wiring for reliability and aging symptoms.
- The process accuracy. As a result of wear and tear, re-calibration of the flowmeter might be necessary. Do not forget to re-enter any subsequent K-factor alterations.
- The indication for low-battery.
- Clean the casing with soapy-water. Do not use any aggressive solvents as these might damage the coating.

5.2. REPAIR

This product cannot be repaired by the user and must be replaced with an equivalent certified product. Repairs should only be carried out by the manufacturer or his authorized agent.

APPENDIX A: TECHNICAL SPECIFICATION

GENERAL

Display	
Type	High intensity reflective numeric and alphanumeric LCD, UV-resistant.
Digits	Seven 17mm (0.67") and eleven 8mm (0.31"). Various symbols and measuring units.
Refresh rate	User definable: 8 times/sec - 30 secs.
Backlight	Bi-color configurable LED-backlight - green or amber. Intensity adjustable from the keyboard.
Enclosures	
General	Die-cast aluminum or GRP (Glassfibre Reinforced Polyamide) enclosure with Polycarbonate window, silicone and EPDM gaskets. UV stabilized and flame retardant material.
Control Keys	Three industrial micro-switch keys. UV-resistant silicone keypad.
Painting	Aluminum enclosure only: UV-resistant 2-component industrial painting.
Panel-mount enclosures	Dimensions: 130 x 120 x 60mm (5.10" x 4.72" x 2.38") – LxHxD.
Classification	IP65 / NEMA 4X
Panel cut-out	115 x 98mm (4.53" x 3.86") LxH.
Type ER-RMP	GRP panel-mount enclosure
Type ER-RMA	Aluminum panel-mount enclosure
Field/wall-mount enclosures	Dimensions: 130 x 120 x 75mm (5.10" x 4.72" x 2.95") – LxHxD.
Classification	IP67 / NEMA4X
Aluminum enclosures	
Type ER-RMA	Drilling: 2x PG9 – 1x M20.
GRP enclosures	
Type ER-RMP	Drilling: 2x 16mm (0.63") – 1x 20mm (0.78").
Round meter-mount enclosures	Dimensions: Ø 161 x 87.5mm (5.10" x 2.38") – ØxD.
Classification	IP67 / NEMA 4X
Type ER-M	Aluminum meter-mount enclosure
Operating temperature	
Operational	-40°C to +80°C (-40°F to +178°F).
Power requirements	
	Lithium battery - life-time depends upon settings - up to 5 years.
	16-30 V DC. Power consumption max. 1 Watt.
	8-30 V DC (also available with battery). Power consumption max. 0.3 Watt.
Sensor excitation	
	Sensor supply voltage: 3.2V DC for pulse signals and 1.2V DC for coil pick-up. Please note: this is not a real sensor supply. Only suitable for sensors with a very low power consumption like coils (sine wave) and reed-switches. Analog sensors type A / U: sensor supply not available.
	With pulse input type P: sensor supply 1.2, 3.2, 8.2V DC - max. 5mA@8.2V DC. With analog input type A / U: as connected power supply voltage (internally linked)
Terminal connections	
Type:	Removable plug-in terminal strip. Wire max. 1.5mm ² and 2.5mm ²
Data protection	
Type	EEPROM backup of all settings. Data retention at least 10 years.
Pass code	Configuration settings can be pass code protected.
Environment	
Electromagnetic compatibility	Compliant ref: EN 61326 (1997), EN 61010-1 (1993)
Low voltage directive	Compliant ref: EN60950.

INPUTS

Flowmeter	
Type P	NPN, reed-switch
Frequency	Minimum 0 Hz - maximum 7 kHz for flowrate. Maximum frequency depends on signal type and internal low-pass filter. E.g. Reed switch with low-pass filter: max. frequency 120 Hz.
K-Factor	0.000010 - 9,999,999 with variable decimal position.
Low-pass filter	Available for all pulse signals.

OPERATIONAL

Operator functions	
Displayed functions	<ul style="list-style-type: none"> total and/or flowrate. total and accumulated total. total can be reset to zero by pressing the CLEAR-key twice.

Total	
Digits	7 digits.
Units	L, m3, GAL, USGAL, KG, lb, bbl, no unit.
Decimals	0 - 1 - 2 or 3.
Note	total can be reset to zero.

Accumulated total	
Digits	11 digits.
Units / decimals	according to selection for total.

Flowrate	
Digits	7 digits.
Units	mL, L, m3, Gallons, KG, Ton, lb, bl, cf, RND, ft3, scf, Nm3, NI, igal - no units.
Decimals	0 - 1 - 2 or 3.
Time units	/sec - /min - /hr - /day.

APPENDIX B: PROBLEM SOLVING

In this appendix, several problems are included that can occur when the ER is going to be installed or while it is in operation.

Flowmeter does not generate pulses:

Check:

- Signal selection SETUP - 51,
- Pulse amplitude (par. 4.4.2. / 4.4.3.),
- Flowmeter, wiring and connection of terminal connectors (par. 4.4.2. / 4.4.3.),
- Power supply of flowmeter (par. 4.4.2. / 4.4.3.).

Flowmeter generates "too many pulses":

Check:

- Settings for total and Flowrate: SETUP 11-14 and 21-27,
- Type of signal selected with actual signal generated - SETUP - 51,
- Sensitivity of coil input - SETUP - 51 and par. 4.4.2 / 4.4.3.
- Proper grounding of the ER - par. 4.4.1.
- Use screened wire for flowmeter signals and connect screen to the "⊥" terminal.

Flowrate displays "0 / zero" while there is flow (total is counting):

Check:

- SETUP 22 / 25: are the K-factor and time unit correct?
- SETUP 26 / 27: The unit has to count the number of pulses according to SETUP 26 within the time according to SETUP 27. Make sure that 27 is set to 10.0 seconds for example : the result is that the unit has at least 10 seconds time to measure the number of pulses according to SETUP 26.

The pass code is unknown:

If the pass code is not 1234, there is only one possibility left: call your supplier.

ALARM

When the alarm flag starts to blink an internal alarm condition has occurred. Press the "select button" several times to display the 5-digit error code. The codes are:

- 0001: irrecoverable display-data error: data on the display might be corrupted.
 0002: irrecoverable data-storage error: the programming cycle might have gone wrong: check programmed values.
 0003: error 1 and error 2 occurred simultaneously

The alarm condition will almost certainly be handled internally and if all mentioned values still appear correct, no intervention by the operator is needed. If the alarm occurs more often or stays active for a longer time, please contact your supplier.

INDEX OF THIS MANUAL

accumulated total	7	low-battery	7
actual settings	28	main-function	9
backlight	21	maintenance	22
color	14	manual version	3
density	14	model	15
battery life time	14, 22	operational	6
clear total	7	operator level	7
configuration	8	pass code	15, 25
contents	4	power supply	20
dimensions	17	problem solving	25
display		pulse-signal NPN	20
function	14	rate / total	7
update time	14	reed-switch:	21
flowmeter		sensor supply voltage	20
signal	15	serial number	15
input	20	setup-level	8
flowrate		software version	3
calculation	13	subfunction	9
cut-off time	13	tagnumber	15
decimals	13	technical specification	23
decimals k-factor	13	terminal connectors	19
measuring unit	13	total	
time unit	13	decimals	12
functional description	5	decimals k-factor	12
hardware version	3	k-factor	12, 13
installation	16	measuring unit	12
IP classification	16	version software	15
keys	6		

LIST OF FIGURES IN THIS MANUAL

Fig. 1: Typical application for the ER	5
Fig. 2: Control Panel.....	6
Fig. 3: Example of display information during process.	7
Fig. 4: Example of low-battery alarm.....	7
Fig. 5: Dimensions Aluminum enclosures.....	17
Fig. 6: Dimensions GRP enclosures.....	18
Fig. 6A: Dimensions ER-M series Meter mount enclosures.....	18
Fig. 7: Grounding aluminum enclosure	19
Fig. 8: Overview of terminal connectors ER.....	19

LIST OF CONFIGURATION SETTINGS

SETTING	DEFAULT	DATE :	DATE :
---------	---------	--------	--------

1 - TOTAL	Enter your settings here		
11 unit	L		
12 decimals	0000000		
13 K-factor	0000001		
14 decimals K-factor	0		

2 - FLOWRATE			
21 unit	L		
22 time unit	/min		
23 decimals	0000000		
24 K-factor	0000001		
25 decimals K-factor	0		
26 calculation / pulses	010		
27 cut-off time	30.0 sec.		

3 - DISPLAY			
31 function	total		
32 backlight	off		
33 brightness	5		

4 - POWER MANAGEMENT			
41 LCD-new	1 sec.		
42 mode	operational		

5 - FLOWMETER			
51 signal	NPN		

6 - OTHERS			
61 model	ER	ER	ER
62 software version	MCN0121	MCN0121	MCN0121
63 serial number	-----	-----	-----
64 pass code	0000		
65 tagnumber	0000000		

