

ZoneDefender Pro range - 1-2 Phase

The most compact,
powerful, feature-rich AC
surge protector available

- **80kA, 100kA & 120kA surge-current rating per phase**
- **Includes high-performance EMI/RFI filtering**
- **LED status indication via solid state diagnostics plus remote indication contacts**
- **Built-in audible alarm**
- **Thermal and short circuit fusing**
- **Short circuit current rating: 200k AIC**
- **UL 1449 4th Edition Listed**
- **10 year product warranty**



The **ZoneDefender PRO range** is a versatile, high performance surge protector designed for use in a wide variety of industrial, institutional and commercial applications. The ZoneDefender PRO is the most compact, powerful, feature-rich surge protector on the market today. State-of-the-art circuitry protects equipment from high frequency noise as well as from damaging electrical transients and high-energy disturbances. In addition, the ZoneDefender PRO range offers cost-effective high capacity protection along with application versatility; features which make the range the ultimate surge protection solution.

ZoneDefender PRO units provide protection between Line to Neutral, Line to Ground, Line to Line and Neutral to Ground. Utilizing Metal Oxide Varistor (MOV) technology, the ZoneDefender PRO's protection circuits are highly reliable, dual-redundant varistor networks ensuring your site is never unprotected. Fully automatic in operation, ZoneDefender PRO reacts immediately, clamping voltage surges without causing undue leakage losses under normal operation. No operator intervention is required, ZoneDefender PRO resets automatically and is maintenance free.

Suitable for all AC power applications, ZoneDefender PRO devices provide protection for AC power supplies with no restriction to the amount of load current.

Thermal fusing is incorporated into each ZoneDefender PRO as an additional safety feature. Short circuit protection with 200kA AIC rating. is also supplied, as standard, for added peace of mind.

ZoneDefender PRO offers an LED status indication allowing each varistor network to be continually monitored and indicated by LEDs on the front panel of the device. In addition, remote monitoring is enabled by the unit's remote indication contacts.

Installation is simple- the ZoneDefender PRO devices can be easily surface or nipple mounted.

The ZoneDefender PRO range is UL 1449 4th Edition Listed and boasts an unrivaled 10 year 'no questions asked' manufacturers product warranty. ZoneDefender PRO devices also exceed the requirements of ANSI/IEEE C62.45 and ANSI/IEEE C62.41.

MTL 901-104 ZD Pro 1-2 Phase

September 2022

SPECIFICATION

Maximum surge current (I_{max})

80kA, 100kA & 120kA (8/20μs)

Maximum continuous operating voltage

120/240 versions - 140Vac/270Vac

Lines protected AC

L-N, L-G, L-L, N-G

Duty cycle performance (8/20μs)

Rated 1 impulse
10,000A >6,500 Impulses
100A infinite

Long duration current pulse (10/1,000μs) capability

3,600A (tested)

Frequency range

47Hz to 63Hz

Ambient temperature limits

-40°F to +185°F working
-40°C to +85°C working

Humidity

95% RH (non-condensing)

Enclosure

NEMA 1, 2, 3,3R,4, 4X 12 and 13 (IP66)

Terminals

#10 AWG (5mm²)

Mounting

Surface mount by 0.21" (5mm) diameter holes

Remote contacts

Form C (NC, NO, C) 60W DC, 120VA AC, 3A max.

Indication

Green LED on } Power protection in all modes, all phases
Red LED off }

Green LED off } Protection fault (remote indication alarm via contacts & audible alarm)
Red LED on }

Green LED on } Neutral/ground fault (voltage potential)
Red LED on }

Audible Alarm

90dB

EMI/RFI Attenuation

-75dB maximum 100kHz to 100MHz

Weight

2.5 kg (5.5 lbs) - Split Phase
1.6 kg (3.5 lbs) - Single phase

Dimensions

See Figure 1 and Figure 2

SCCR Rating

Suitable for use on a circuit capable of delivering not more than 200,000 rms symmetrical Amperes, 480V max

EMC compliance

BS EN 61326-1:2013
IEC 61643-11:2011

Ratings in compliance with IEC6164-11

I_{max} = 80kA, 100kA & 120kA
I_{imp} = 5kA (10/350)*

*All current results are per phase.

DIMENSIONS

Figure 1. Split phase dimensions

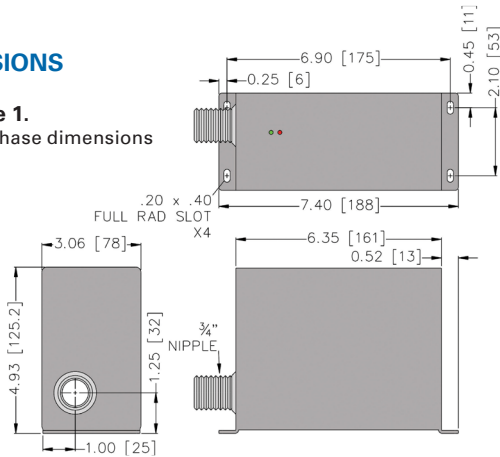
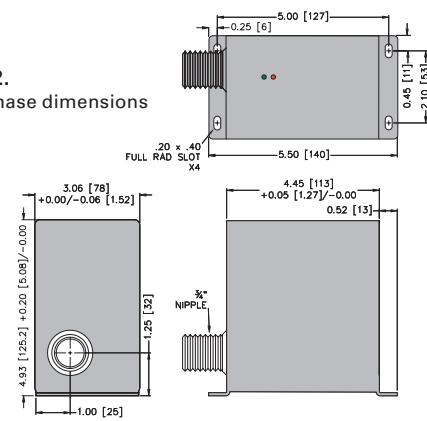

Figure 2. Single phase dimensions



TO ORDER SPECIFY:

Model	Working voltage	UL1449 VPR 4th Edition	Limiting voltage		U _P	Ringwave @200A	Phase types
			@ 3kA	@ 10kA (In)			
80kA versions	(V)	(V)	(V)	(V)	(kV)	(V)	
ZD16700	120	600	580	800	0.8	60	Single phase 2-wire
ZD16701	120/240	600	580	800	0.8	60	Split phase 3-wire
ZD16709	240	1200	890	1200	1.2	75	Single phase 2-wire TT
ZD16900	120TT	600/1200	580/890	800/1300	0.8/1.3	60/75	Single phase 2-wire TT
ZD16901	120/240TT	600/1200	580/890	800/1300	0.8/1.3	60/75	Split phase 3-wire TT
100kA versions							
ZD16730	120	600	580	800	0.8	60	Single phase 2-wire
ZD16731	120/240	600	580	800	0.8	60	Split phase 3-wire
ZD16739	240	1200	890	1200	1.2	75	Single phase 2-wire TT
120kA versions							
ZD16740	120	600	580	800	0.8	60	Single phase 2-wire
ZD16741	120/240	600	580	800	0.8	60	Split phase 3-wire
ZD16749	240	1200	890	1200	1.2	75	Single phase 2-wire TT

APPROVALS:

Country	Standard/Authority	Approved for	Product
USA Canada	UL 1449 4th Edition Listed	AC power product	ZD16700, ZD16701, ZD16709, ZD16900, ZD16901, ZD16730, ZD16731, ZD16739, ZD16740, ZD16741, ZD16749



Eaton Electric Limited,
Great Marlings, Butterfield, Luton
Beds, LU2 8DL, UK.
Tel: + 44 (0)1582 723633 Fax: + 44 (0)1582 422283
E-mail: mtlenquiry@eaton.com
www.mtl-inst.com

© 2022 Eaton
All Rights Reserved
Pub. No. EPS 901-104_ZD Pro 1-2 Phase Rev D 070922
September 2022

EUROPE (EMEA):
+44 (0)1582 723633
mtlenquiry@eaton.com

THE AMERICAS:
+1 800 835 7075
mtl-us-info@eaton.com

ASIA-PACIFIC:
+65 6 645 9888
sales.mtlsing@eaton.com

The given data is only intended as a product description and should not be regarded as a legal warranty of properties or guarantee. In the interest of further technical developments, we reserve the right to make design changes.