

Rosemount™ Slurry Magnetic Flow Meter



Featuring the Rosemount 8782 transmitter and Rosemount MS Sensor



- Industry leading performance:
 - Standard reference accuracy of 0.25% of rate
 - High reference accuracy of 0.15% of rate (optional)
 - For complete specifications, see [Product Specifications](#).
- Rosemount 8782 Transmitter: Wall mount design, backlit display (optional), 15-Button tactile key pad (optional)
- Available in 4-20mA with HART®, Intrinsically Safe (I.S.) outputs, Process Diagnostics, and Smart™ Meter Verification to improve reliability and performance
- Rosemount Magflow Slurry (MS) sensor: Fully welded sensor available for maximum protection
- Rosemount 8785 Calibration Standard for on-site calibration capabilities, and independent verification of meter calibration

Product Overview

The Rosemount Slurry Magnetic Flow Meter is available in a variety of sizes and configurations to ensure compatibility with many applications and installations.

Appearance	Characteristics
8782 Transmitter 	<ul style="list-style-type: none"> ■ Wall mount configuration for wall or pipe mounting ■ HART/Analog and pulse outputs available ■ Process diagnostics and Smart Meter Verification available ■ Local Operator Interface with Display (shown, optional) or LCD Display only (optional) ■ Two discrete channels (optional) ■ Designed for use with the MS sensor, compatible with the 8707 high signal sensor.
MS Sensor 	<ul style="list-style-type: none"> ■ Magnetic flow meter sensor designed for high solids content, high pulp stock, or slurry flows ■ Flanged process connections ■ Fully welded, sealed coil housing (optional) ■ 3 inch (80 mm) to 36 inch (900 mm) ■ Standard, reference, bullet-nose, and flat electrodes available
8785 Calibration Standard 	<ul style="list-style-type: none"> ■ For independent verification of transmitter calibration ■ Suitable for on-site calibration of transmitter ■ Compatible with the 8782 transmitter

Contents

Product Overview.....	2
Magnetic Flow Meter Diagnostics.....	3
Magnetic flow meter sizing.....	4
Ordering Information.....	7
Product Specifications.....	22
Product Certifications.....	39
Dimensional drawings.....	40

Magnetic Flow Meter Diagnostics

Rosemount diagnostics reduce cost & improve output by enabling new practices

Rosemount Magnetic Flow Meters provide device diagnostics that detect and warn of abnormal situations throughout the life of the meter - from installation to maintenance and meter verification. With Rosemount Magnetic Flow Meter diagnostics enabled, plant availability and throughput can be improved, and costs through simplified installation, maintenance and troubleshooting can be reduced.

Table 1: Magnetic flow meter diagnostics

Diagnostic name	Diagnostic category	Product capability
Basic diagnostics		
Grounding and Wiring Fault	Installation	Standard
Empty Pipe	Process	Standard
Reverse Flow	Process	Standard
Electrode saturation	Installation/process	Standard
Transmitter Fault	Meter Health	Standard
Electronics Temperature	Meter Health	Standard
Coil Circuit Fault	Meter Health	Standard
Advanced diagnostics		
High Process Noise	Process	Suite 1 (DS1)
Coated Electrode Detection	Process	Suite 1 (DS1)
Commanded Smart Meter Verification	Meter Health	Suite 2 (MV)
Continuous Smart Meter Verification	Meter Health	Suite 2 (MV)
4-20 mA Loop Verification	Installation	Suite 2 (MV)

Options for accessing diagnostics

Rosemount magnetic flow meter diagnostics can be accessed through the Local Operator Interface (LOI), ProLink® III Software, a HART Communicator (including AMS Trex Device Communicator), and AMS Device Manager. Contact an Emerson Flow representative (see back page) to activate diagnostics or for diagnostic availability on existing transmitters.

Access diagnostics through the LOI for quick installation, maintenance, and meter verification

Rosemount magnetic flow meter diagnostics are available through the LOI to simplify maintenance.

Access diagnostics through ProLink III Software

Simplify maintenance and troubleshooting practices by utilizing ProLink III Software to access diagnostics and troubleshooting information, log variable data, run Smart Meter Verification, and print verification reports.

Magnetic flow meter sizing

Selecting the appropriate sensor size is an important step when considering a magnetic flow meter. The physical properties of the process fluid, as well as the fluid velocity should be considered. It may be necessary to select a flow sensor that is larger or smaller than the adjacent piping to ensure the fluid velocity is in the recommended flow range for the application.

Table 2: Sizing guidelines

Application	Velocity range (ft/s)	Velocity range (m/s)
Full Range	-39 to +39	-12 to +12
Preferred Service	2 to 20	0.6 to 6.1
Abrasive Slurries	3 to 10	0.9 to 3.1
Non-Abrasive Slurries	5 to 15	1.5 to 4.6

Note

Operation outside these guidelines may also give acceptable performance.

To convert flow rate to velocity, use the appropriate factor listed in [Table 3](#) and the following equation:

$$\text{Velocity} = \frac{\text{Flow Rate}}{\text{Factor}}$$

Example: English units	Example: SI units
Magmeter Size: 4 in. (factor from Table 3 = 39.679) Normal Flow Rate: 300 GPM $\text{Velocity} = \frac{300 \text{ (gpm)}}{39.679}$ <p style="text-align: center;">Velocity = 7.56 ft/s</p>	Magmeter Size: 100 mm (factor from Table 3 = 492.78) Normal Flow Rate: 800 L/min $\text{Velocity} = \frac{800 \text{ (L/min)}}{492.78}$ <p style="text-align: center;">Velocity = 1.62 m/s</p>

Table 3: Line size vs. conversion factor

Nominal line size—Inches (mm)	Gallons per minute factor	Liters per minute factor
3 (80)	23.042	286.17
4 (100)	39.679	492.78
6 (150)	90.048	1,118.3
8 (200)	155.93	1,936.5
10 (250)	245.78	3,052.4
12 (300)	352.51	4,378.0
14 (350)	421.70	5,237.3
16 (400)	550.80	6,840.6
18 (450)	697.19	8,658.6

Table 3: Line size vs. conversion factor (continued)

Nominal line size—Inches (mm)	Gallons per minute factor	Liters per minute factor
20 (500)	866.51	10,761
24 (600)	1,253.2	15,564
30 (750)	2006.0	24,913
36 (900)	2,935.0	36,451

Table 4: Line size vs. velocity/rate

Nominal line size in inches (mm)	Minimum/maximum flow rate							
	Gallons per minute				Liters per minute			
	at 0.04 ft/s (low-flow cutoff)	at 1 ft/s (min range setting)	at 3 ft/s	at 39.37 ft/s (max range setting)	at 0.012 m/s (low-flow cutoff)	at 0.3 m/s (min range setting)	at 1 m/s	at 12 m/s (max range setting)
3 (80)	0.922	23.042	69.13	907.17	3.434	85.85	286.17	3,434.0
4 (100)	1.587	39.679	119.04	1,562.2	5.913	147.84	492.78	5,913.4
6 (150)	3.602	90.048	270.14	3,545.2	13.42	335.50	1,118.3	13,420
8 (200)	6.237	155.93	467.79	6,138.9	23.24	580.96	1,936.5	23,238
10 (250)	9.831	245.78	737.34	9,676.3	36.63	915.73	3,052.4	36,629
12 (300)	14.10	352.51	1,057.5	13,878	52.54	1,313.4	4,378.0	52,535
14 (350)	16.87	421.71	1,265.1	16,603	62.85	1,571.2	5,237.3	62,848
16 (400)	22.03	550.80	1,652.4	21,685	82.09	2,052.2	6,840.6	82,087
18 (450)	27.89	697.19	2,091.6	27,448	103.90	2,597.6	8,658.6	103,903
20 (500)	34.66	866.51	2,599.5	34,114	129.14	3,228.4	10,761	129,137
24 (600)	50.13	1,253.2	3,759.6	49,339	186.77	4,669.2	15,564	186,769
30 (750)	80.24	2,006.0	6,018.0	78,976	298.96	7,474.0	24,913	298,959
36 (900)	117.40	2,935.0	8,805.1	115,553	437.42	10,935	36,451	437,416

Upstream and downstream piping

To ensure specified accuracy over widely varying process conditions, it is recommended to install the sensor with a minimum of five straight pipe diameters upstream and two pipe diameters downstream from the electrode plane.

Figure 1: Upstream and downstream straight pipe diameters

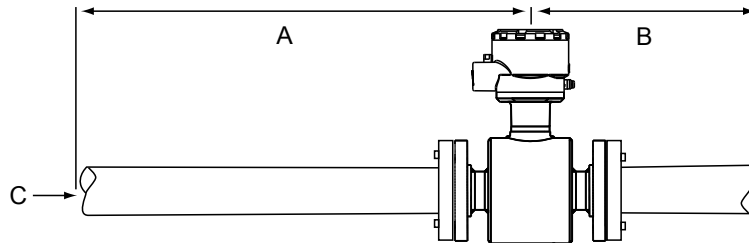

- A. Five pipe diameters (upstream)
- B. Two pipe diameters (downstream)
- C. Flow direction

Installations with reduced upstream and downstream straight runs are possible. In reduced straight run installations, the meter may not meet accuracy specifications. Reported flow rates will still be highly repeatable.

Sensor process reference grounding

In addition to grounding required by applicable safety/electrical standards or codes, a reliable process reference ground path is required between the sensor and the process fluid. Optional grounding rings, process reference electrode, and lining protectors are available with the sensor to ensure proper process reference grounding. See [Table 5](#) and [Table 6](#).

Ordering Information

Rosemount 8782 transmitter



The Rosemount 8782 Transmitter with “Best in Class” performance, coupled with advanced diagnostics, provides unparalleled process management capabilities. An optional backlit 2-line by 16-character display/local operator interface is available. The transmitter can be configured using the 15 button tactile keypad.

Note

The starred (★) offerings represent standard options, and should be selected for best delivery.

Ordering information

Example model code with one selection out of each category: 8782AW 1 A 1 N5 DS2 AX M4 B6 C1 D1 Q4 RT05

Table 5: Requirements - select one from each available choice

Code	Description	
8782	Magnetic Flow Meter Slurry Transmitter	
Transmitter revision level		
A	Revision Level A	★
Transmitter mount		
W	Remote wall mount	★
Power supply		
1	AC power supply (90–250VAC, 50/60Hz)	★
2	DC power supply (12–42VDC)	★
Outputs		
A	4–20mA output with Digital HART Protocol and scalable pulse output	★
B ⁽¹⁾	4–20mA intrinsically safe output with Digital HART Protocol and scalable intrinsically safe pulse output	★
Conduit entry		
1	½–14 NPT	★
2 ⁽²⁾	M20–1.5	★

Table 5: Requirements - select one from each available choice (continued)

Code	Description	
Safety approvals		
NH	Ordinary locations (non-hazardous)	★
ND	ATEX dust	★
NF	IECEX dust	★
N1 ⁽³⁾	ATEX non-sparking and dust	★
N5	North America approvals, Class I Div 2, non-incendive and dust	★
N7 ⁽³⁾	IECEX non-sparking and dust	★

(1) *Intrinsically safe outputs must be externally powered.*

(2) *M20–1.5 connections provided with an adapter.*

(3) *DC power only.*

Table 6: Options – Not required, but must be included in the model number if desired

Code	Description	
Meter verification		
MV	Smart Meter Verification Professional	★
Advanced diagnostics		
DS1	Process diagnostics; high process noise; electrode coating	★
Discrete input/discrete output		
AX	Two discrete channels (DI/DO 1, DO 2)	★
Display		
M4	Local operator interface with display	★
M5	Local display only	★
Mounting bracket		
B6	316 stainless steel 4-bolt kit and for 2 inch pipe mount	★
Software configuration		
C1	Custom configuration (completed CDS form required with order)	★
Calibration accuracy		
D1 ⁽¹⁾	High accuracy calibration	
Quality certificate		
Q4	Calibration data, per ISO 10474 3.1B / EN 10204 3.1	★
Remote cable kit		
RTxx	Standard temperature component cables (-20°C to 75°C) For xx: 01 = 10 ft, 02 = 20 ft, 03 = 30 ft, 04 = 40 ft, 05 = 50 ft, 10 = 100 ft, 15 = 150 ft, 20 = 200 ft, 25 = 250 ft, 50 = 500 ft	★
RHxx	Extended temperature component cables (-50°C to 125°C) For xx: 01 = 10 ft, 02 = 20 ft, 03 = 30 ft, 04 = 40 ft, 05 = 50 ft, 10 = 100 ft, 15 = 150 ft, 25 = 250 ft, 50 = 500 ft	★

Table 6: Options – Not required, but must be included in the model number if desired (continued)

Code	Description
Quick Start Guide language	
YF	French
YG	German
YI	Italian
YM	Chinese–Mandarin
YP	Portuguese–Brazil
YR	Russian
YS	Spanish

- (1) *The high accuracy calibration requires the transmitter and sensor to be ordered together and paired during calibration. Spare or replacement transmitters ordered with the D1 option will receive standard calibration.*

Rosemount MS sensor



All sensors are fabricated from stainless and carbon steel and welded and sealed to protect against moisture and other contaminants. Sizes range from 3 inch (80 mm) to 36 inch (900 mm). The sealed housing ensures maximum sensor reliability by protecting all internal components and wiring from the most hostile environments.

Note

The starred (★) offerings represent standard options, and should be selected for best delivery.

Model code structure

Example model code with one selection out of each category: MS 060 A R 1 T S A C A 1 M0 NH D2

After selecting the requirements in [Table 7](#), options can be selected as needed from [Table 8](#).

Ordering requirements and options

Table 7: Requirements

Code	Description							
Base model								
MS	Base model							
Line size/Liner availability ("✓" = available)								
Code	Line size	★	PTFE code T	Poly code P	Neoprene code N	Linatex code L	Adiprine code D	PFA+ code K
030	3 inch (80 mm)	★	✓	✓	✓	✓	✓	✓
040	4 inch (100 mm)	★	✓	✓	✓	✓	✓	✓
060	6 inch (150 mm)	★	✓	✓	✓	✓	✓	✓
080	8 inch (200 mm)	★	✓	✓	✓	✓	✓	✓
100	10 inch (250 mm)	★	✓	✓	✓	✓	✓	✓
120	12 inch (300 mm)	★	✓	✓	✓	✓	✓	✓
140	14 inch (350 mm)		✓	✓	✓	✓		✓
160	16 inch (400 mm)		✓	✓	✓	✓		
180	18 inch (450 mm)		✓	✓	✓	✓		
200	20 inch (500 mm)		✓	✓	✓	✓		
240	24 inch (600 mm)		✓	✓	✓	✓		
300	30 inch (750 mm)		✓	✓	✓	✓		
360	36 inch (900 mm)		✓	✓	✓	✓		

Table 7: Requirements (continued)

Code	Description	
Revision level		
A	Revision level A	★
Mounting configuration		
R	Remote mount	★
Conduit entries		
1	½ – 14 NPT	★
2	M20 – 1.5	★
Lining material⁽¹⁾		
T	PTFE. Available in the following line sizes: 3 inch to 24 inch (80 mm to 600 mm) ASME Class 150, Class 300, Class 600 (derated), and EN 1092-1 30 inch and 36 inch (750 mm and 900 mm) Class 150 and Class 300	★
P	Polyurethane. Available in the following line sizes: 3 inch to 24 inch (80 mm to 600 mm) ASME Class 150, Class 300, and EN 1092-1, PN16 and PN25 30 inch and 36 inch (750 mm and 900 mm) Class 150 3 inch to 18 inch (80 mm to 450 mm) ASME Class 600, EN1092-1 PN40 3 inch to 12 inch (80 mm to 300 mm) ASME Class 900 3 inch to 10 inch (80 mm to 250 mm) ASME Class 1500, Class 2500	★
N	Neoprene. Available in the following line sizes: 3 inch to 24 inch (80 mm to 600 mm) ASME Class 150, Class 300, Class 600 (fully rated) and EN 1092-1 30 inch and 36 inch (750 mm and 900 mm), Class 150, Class 300 3 inch to 20 inch (80 mm to 500 mm) ASME Class 900 3 inch to 12 inch (80 mm to 300 mm) ASME Class 1500 3 inch to 8 inch (80 mm to 200 mm) ASME Class 2500 36 inch (900 mm) EN 1092-1 PN10 and PN16	★
L	Linatex - natural rubber. Available in the following line sizes: 3 inch to 24 inch (80 mm to 600 mm) ASME Class 150, Class 300, Class 600 (fully rated) and EN 1092-1 30 inch and 36 inch (750 mm and 900 mm), Class 150, Class 300 3 inch to 20 inch (80 mm to 500 mm) ASME Class 900 3 inch to 12 inch (80 mm to 300 mm) ASME Class 1500 3 inch to 8 inch (80 mm to 200 mm) ASME Class 2500 36 inch (900 mm) EN 1092-1 PN10 and PN16	
D	Adiprene. Available in the following line sizes: 3 inch to 12 inch (80 mm to 300 mm) ASME Class 150, Class 300, Class 600, and Class 900 3 inch to 10 inch (80 mm to 250 mm) EN1092-1 3 inch to 8 inch (80 mm to 200 mm) ASME Class 1500, Class 2500	
K	PFA+. Available in line sizes 3 inch to 14 inch (80 mm to 350 mm) ASME Class 150, Class 300, and EN 1092-1 Flanges.	

Table 7: Requirements (continued)

Code	Description	
Electrode material		
S	316L stainless steel	★
H	Nickel alloy 276 (UNS N10276)	★
P	80% platinum - 20% iridium	★
N	Titanium	★
W	Tungsten-carbide coated 316L	★
Y	Tungsten-carbide coated nickel alloy 276	
Electrode type		
A	2 Measurement electrodes - standard	★
B ⁽²⁾	2 Measurement electrodes - bulletnose	★
T	2 Measurement electrodes - flat head	
E	2 Measurement electrodes plus 1 reference electrode - standard	★
F ⁽²⁾	2 Measurement electrodes plus 1 reference electrode - bulletnose	★
U	2 Measurement electrodes plus 1 reference electrode - flat head	
Flange material		
C	Carbon steel	★
S	304/304L stainless steel	★
P	316/316L stainless steel	
Flange type		
A	Slip-on raised face	★
B	Slip-on flat face	
C	Weld-neck raised face	
D	Weld-neck flat face	
E	Weld-neck RTJ groove	
G ⁽³⁾	Grooved coupling	★

Table 7: Requirements (continued)

Code	Description	
Flange rating		
1	Class 150: ASME B16.5, 3 to 24 inch Mod MSS-SP44, 30 and 36 inch with Slip-on flange ASME B16.47 Series A, 30 and 36 inch with Weld-neck flange	★
3	Class 300: ASME B16.5, 3 to 24 inch Mod MSS-SP44, 30 and 36 inch with Slip-on flange ASME B16.47 Series A, 30 and 36 inch with Weld-neck flange	★
6	ASME B16.5, Class 600 (maximum working pressure: derated 1000 psig)	
7	ASME B16.5, Class 600	
g ⁽⁴⁾	ASME B16.5, Class 900	
M ⁽⁴⁾	ASME B16.5, Class 1500	
N ⁽⁴⁾	ASME B16.5, Class 2500	
D	EN 1092-1, PN10	
E	EN 1092-1, PN16	★
F	EN 1092-1, PN25	
H	EN 1092-1, PN40	★
K	AS2129, Table D	
L	AS2129, Table E	
p ⁽⁵⁾	JIS B 2220, 10K	
R ⁽⁵⁾	JIS B 2220, 20K	
T ⁽⁶⁾	JIS B 2220, 40K	
U	AS4087, PN16	
W	AS4087, PN21	
Y	AS4087, PN35	
Coil housing configuration		
M0	Sealed, welded housing: Potted terminal block with NH approval Field replaceable terminal block with Nx Approval Field replaceable socket module with Kx Approval	★
M1 ⁽⁷⁾	Sealed, welded housing with pressure relief port and field replaceable socket module	
M2	Sealed, welded housing with sealed electrode compartments and field replaceable socket module	
M4	Sealed, welded housing with sealed electrode compartments with port and field replaceable socket module	

Table 7: Requirements (continued)

Code	Description	
Safety approval		
NH	Ordinary locations - (non-hazardous)	★
ND	ATEX dust	★
NF	IECEx dust	★
N1	ATEX Non-Sparking, Increased Safety (Ex ec) with Intrinsically Safe Electrodes; ATEX dust	★
N5	North America approvals, Class I Div 2, non-incendive with Intrinsically Safe electrodes and dust	★
N7	IECEx Non-Sparking, Increased Safety (Ex ec) with Intrinsically Safe Electrodes; IECEx dust	★
K1	ATEX increased safety (Ex eb) with intrinsically safe electrodes; ATEX dust	
K6	North America Class I Zone 1 with Intrinsically Safe Electrodes; dust	
K7	IECEx increased safety (Ex eb) with intrinsically safe electrodes; IECEx dust	

- (1) Availability based on line size and flange type/rating. See [Table 9](#) (slip on flanges) and [Table 10](#) (weld neck). Consult an Emerson Flow representative (see back page) for availability with AS or JIS flanges.
- (2) Not available in Tantalum.
- (3) Grooved Coupling is only available with flange codes SG1 or PG1 in line sizes 3 inch to 10 inch (80mm to 250mm); not available with grounding rings or lining protectors. See [Table 22](#) for Maximum Working Pressure.
- (4) Not available with lining protectors.
- (5) Available line sizes 3 inch to 24 inch (80 mm to 600 mm); not available with lining protectors.
- (6) Available line sizes 3 inch to 16 inch (80 mm to 400 mm); not available with lining protectors.
- (7) Pressure relief valve must be installed appropriately to maintain the approvals on the meter. Recovery piping diameter must not be smaller than M6 to avoid building pressure after the valve.

Options

Note

These are not required, but they must be included in the model number if desired.

Table 8: Options

Code	Description	
Grounding rings or lining protectors⁽¹⁾		
G1	(2) 316L SST ground rings	★
G2	(2) Nickel alloy 276 (UNS N10276) ground rings	★
G3	(2) Titanium ground rings	
G4	(2) Tantalum ground rings	
G5	(1) 316L SST ground ring	★
G6	(1) Nickel alloy 276 (UNS N10276) ground ring	★
G7	(1) Titanium ground ring	
G8	(1) Tantalum ground ring	
L1	(2) 316L SST lining protectors	★
L2	(2) Nickel alloy 276 (UNS N10276) lining protectors	
L3	(2) Titanium lining protectors	
L5	(1) 316L SST lining protector	★
L6	(1) Nickel alloy 276 (UNS N10276) lining protector	
L7	(1) Titanium lining protector	
Special lay length⁽²⁾		
H2	8701 lay length	
H4	ISO lay length	
Calibration option		
D1 ⁽³⁾	High accuracy calibration (0.15% of rate for matched sensor and transmitter).	
Dual calibration option		
D2	Dual calibration at 500 mA and 2A	
Quality certificate		
Q4	Calibration certificate per ISO 10474 3.1B/EN 10204 3.1	★
Q5	Hydrostatic test certificate	★
Q8	Material traceability per ISO 10474 3.1B/EN 10204 3.1	★
Q25	Certificate of compliance to NACE MR0175 and MR0103	★
Q66	Weld procedure package (weld map, weld procedure specification, weld procedure qualification record, welder performance qualification)	★
Q70	NDE weld examination inspection certificate, ISO 10474 3.1B	
Q71 ⁽⁴⁾	NDE weld examination inspection certificate, ISO 10474 3.1B with images	
Q76	Positive material identification (PMI) on flanges and pipe, per ASTM E1476-97	
Q77	Positive Material Identification (PMI) with Carbon Content on Flange and Pipe per ASTM E1476-97	

Table 8: Options (continued)

Code	Description	
Enhanced corrosion resistance options		
SJ ⁽⁵⁾	316 SST remote junction box	
SH ⁽⁵⁾	316 SST coil housing and remote junction box	
European Pressure Equipment Directive		
PD	European Pressure Equipment Directive (PED) certification	★
Special paint		
V1	Coal tar paint	
V2	Offshore/near shore marine paint (3 layer epoxy)	
Canadian registration number		
CR	Canadian Registration Number (CRN) certification	★
Non-standard calibration verification		
P05 ⁽⁶⁾	5 Point calibration verification	
P10 ⁽⁷⁾	10 Point calibration verification	
Dual seal		
DS	Dual seal per ISA/ANSI 12.27.01	
Witness		
WG	Witness inspection	
Quick Install Guide language		
YF	French	★
YG	German	★
YI	Italian	★
YM	Chinese–Mandarin	★
YP	Portuguese–Brazil	★
YR	Russian	★
YS	Spanish	★

(1) *Grounding Rings and Lining Protectors provide the same process reference function.*

(2) *Consult Technical Support for Special Lay Length availability; Lining material and flange type/rating dependent.*

(3) *The high accuracy calibration requires the transmitter and sensor to be ordered together and paired during calibration. Spare or replacement sensors ordered with the D1 option will receive standard calibration.*

(4) *Weld-Neck only.*

(5) *Not available with US/Canadian Approval N5.*

(6) *Available for: 3 inch to 24 inch (80 mm to 600 mm) Velocities 1, 3, 5, 7, 10 ft/s; 30 inch (700 mm) Velocities 1, 3, 5, 7, 8 ft/s; 36 inch (900 mm) Velocities 1, 2, 3, 5, 6 ft/s.*

(7) *Available for: 3 inch to 24 inch (80 mm to 600 mm) Velocities 1, 2, 3, 4, 5, 6, 7, 8, 9, 10 ft/s; 30 inch to 36 inch (700 mm to 900 mm) not available.*

Slip on flanges

Table 9: Slip on flange options by line size

Size code	Flange code and rating																
	1	3	6	7	9	D	E	F	H	K	L	P	R	T	U	W	Y
	ASME Class 150	ASME Class 300	ASME Class 600 Derated	ASME Class 600 Full Rated	ASME Class 900	EN PN10	EN PN16	EN PN25	EN PN40	AS2129 Table D	AS2129 Table E	JIS 10K	JIS 20K	JIS 40K	AS4087 PN16	AS4087 PN21	AS4087 PN35
030	✓	✓	✓	✓	✓		✓		✓	✓	✓	✓	✓	✓	✓	✓	✓
040	✓	✓	✓	✓	✓		✓		✓	✓	✓	✓	✓	✓	✓	✓	✓
060	✓	✓	✓	✓	✓		✓	✓	✓	✓	✓	✓	✓	✓	✓	✓	✓
080	✓	✓	✓	✓	✓	✓	✓	✓	✓	✓	✓	✓	✓	✓	✓	✓	✓
100	✓	✓	✓	✓	✓	✓	✓	✓	✓	✓	✓	✓	✓	✓	✓	✓	✓
120	✓	✓	✓	✓	✓	✓	✓	✓	✓	✓	✓	✓	✓	✓	✓	✓	✓
140	✓	✓	✓	✓	✓	✓	✓	✓	✓	✓	✓	✓	✓	✓	✓	✓	✓
160	✓	✓	✓	✓	✓	✓	✓	✓	✓	✓	✓	✓	✓	✓	✓	✓	✓
180	✓	✓	✓	✓	✓	✓	✓	✓	✓	✓	✓	✓	✓		✓	✓	✓
200	✓	✓	✓	✓	✓	✓	✓	✓	✓	✓	✓	✓	✓		✓	✓	✓
240	✓	✓	✓	✓		✓	✓	✓	✓	✓	✓	✓	✓		✓	✓	✓
300	✓ ⁽¹⁾	✓ ⁽¹⁾								✓	✓				✓	✓	✓
360	✓ ⁽¹⁾	✓ ⁽¹⁾								✓	✓				✓	✓	✓

(1) Modified MSS-SP44.

Weld neck flanges

Table 10: Weld neck flange options by line size

Size code	Flange code and rating										
	1	3	6	7	9	D	E	F	H	M	N
	ASME Class 150	ASME Class 300	ASME Class 600 Derated	ASME Class 600 Full Rated	ASME Class 900	EN PN10	EN PN16	EN PN25	EN PN40	ASME Class 1500	ASME Class 2500
030	✓	✓	✓	✓	✓				✓	✓	✓
040	✓	✓	✓	✓	✓		✓		✓	✓	✓
060	✓	✓	✓	✓	✓		✓	✓	✓	✓	✓

Table 10: Weld neck flange options by line size (continued)

Size code	Flange code and rating										
	1	3	6	7	9	D	E	F	H	M	N
	ASME Class 150	ASME Class 300	ASME Class 600 Derated	ASME Class 600 Full Rated	ASME Class 900	EN PN10	EN PN16	EN PN25	EN PN40	ASME Class 1500	ASME Class 2500
080	✓	✓	✓	✓	✓	✓	✓	✓	✓	✓	✓
100	✓	✓	✓	✓	✓	✓	✓	✓	✓	✓	
120	✓	✓	✓	✓	✓	✓	✓	✓	✓	✓	
140	✓	✓	✓	✓	✓	✓	✓	✓	✓		
160	✓	✓	✓	✓	✓	✓	✓	✓	✓		
180	✓	✓	✓	✓	✓	✓	✓	✓	✓		
200	✓	✓	✓	✓	✓	✓	✓	✓	✓		
240	✓	✓	✓	✓		✓	✓	✓	✓		
300	✓ ⁽¹⁾	✓ ⁽¹⁾									
360	✓ ⁽¹⁾	✓ ⁽¹⁾				✓	✓				

(1) ASME B16.47 Series A.

Rosemount 8785 Slurry Calibration Standard

Table 11: Rosemount 8785 Slurry Calibration Standard ordering information

Model	Product
8785	Slurry Magnetic Flow Meter Calibration Standard
Transmitter revision level	
A	Revision level A
Calibrator version	
1	Standard version for use with the 8782 Slurry Transmitter
Quality certificate	
Q4	Calibration data per ISO 10474 3.1B/EN 10204 3.1

Ordering flowmeter equipment

Ordering procedure

To order, select the desired sensor and/or transmitter by specifying model codes from the ordering table.

Note the cable specification requirements.

Standard configuration

Unless the Configuration Data Sheet is completed, the transmitter will be shipped as follows:

Engineering units:	ft/sec
4mA:	0
20mA:	30
Sensor size:	3-in.
Empty pipe:	On
Sensor calibration number:	1000085010000000

Custom configuration (option code C1)

If Option Code C1 is ordered, the Configuration Data Sheet (CDS) must be submitted at the time of order.

Standard tagging

Instrument tags for the transmitter and sensors are as follows:

- 316SST laser etched label, permanently attached
- Main label - Tag name: 1 line 21 characters
- Additional 316SST 'wire-on' tag available: 5 lines, 17 characters per line (6mm height)

Interconnecting cable

Interconnecting cables are required to connect a remote mount transmitter to the sensor. When ordering cable, review the hazardous area approval requirements and the installation location requirements for proper cable selection.

- Cables can be ordered as part of the transmitter model number or as a spare parts kit.
- Individual component cables require equal lengths of coil drive cable and electrode cable and should be limited to less than 330 feet (100 m). Consult an Emerson Flow representative (see back page) for lengths between 330-1000 feet (100-300 m).

Component cable kits

Standard temp (-20 °C to 75 °C)				
Cable kit #	Description	Component	Rosemount p/n	Alpha p/n
08732-0065-0001 (feet)	Kit, Component Cables, Std Temp, (includes Coil and Electrode)	Coil	08732-0060-0001	2442C
		Electrode	08732-0061-0001	2413C
08732-0065-0002 (meters)	Kit, Component Cables, Std Temp (includes Coil and Electrode)	Coil	08732-0060-0002	2442C
		Electrode	08732-0061-0002	2413C
08732-0065-0003 (feet)	Kit, Component Cables, Std Temp (includes Coil and I. S. Electrode)	Coil	08732-0060-0001	2442C
		I. S. Electrode	08732-0061-0003	Not available
08732-0065-0004 (meters)	Kit, Component Cables, Std Temp (includes Coil and I. S. Electrode)	Coil	08732-0060-0002	2442C
		I.S. Electrode	08732-0061-0004	Not available

Extended temp (-50 °C to 125 °C)				
Cable kit #	Description	Component	Rosemount p/n	Alpha p/n
08732-0065-1001 (feet)	Kit, Component Cables, Ext Temp (includes Coil and Electrode)	Coil	08732-0060-1001	Not available
		Electrode	08732-0061-1001	Not available
08732-0065-1002 (meters)	Kit, Component Cables, Ext Temp (includes Coil and Electrode)	Coil	08732-0060-1002	Not available
		Electrode	08732-0061-1002	Not available
08732-0065-1003 (feet)	Kit, Component Cables, Ext Temp (includes Coil and I. S. Electrode)	Coil	08732-0060-1001	Not available
		I. S. Electrode	08732-0061-1003	Not available
08732-0065-1004 (meters)	Kit, Component Cables, Ext Temp (includes Coil and I. S. Electrode)	Coil	08732-0060-1002	Not available
		I.S. Electrode	08732-0061-1004	Not available

Product Specifications

Rosemount 8782 Slurry Magnetic Flow Meter Platform Specifications

The tables below outline some of the basic performance, physical, and functional specifications of the Rosemount 8782 Slurry Magnetic Flow Meter platform.

- [Table 12](#) provides an overview of the Rosemount 8782 Transmitter.
- [Table 13](#) provides an overview of the Rosemount MS Sensor.

Table 12: Rosemount 8782 Slurry transmitter specifications

	Model	8782
	Base accuracy ⁽¹⁾	0.25% Standard 0.15% High Accuracy Option
	Mounting	Remote
	Power supply	Global AC or DC
	User interface	LCD display with 15 button tactile keypad LCD display only No display
	Communication protocol	HART 7
	Diagnostics	Basic, MV, DS1
	Sensor compatibility	Rosemount MS and 8707 sensors only
	Detailed specifications	Transmitter specifications
	Ordering information	Rosemount 8782 transmitter

(1) For complete accuracy specifications, please refer to [Transmitter functional specifications](#).

Table 13: Rosemount MS Sensor Specifications

	Model	MS
	Style	Flanged
	Base accuracy ⁽¹⁾	0.25% Standard 0.15% High Accuracy Option
	Line sizes	3 inch to 36 inch (80 mm to 900 mm)
	Design features	Standard process design
	Transmitter compatibility	Rosemount 8782, 8732EM, and 8712EM
	Detailed specifications	MS Sensor Specifications
	Ordering information	Rosemount MS sensor

(1) For complete accuracy specifications, refer to the sensor detailed specifications.

Table 14: Lining Material Selection



Liner material	General characteristics
PFA+ 	Best permeation resistance Best chemical resistance Better abrasion resistance than PTFE Best high temperature capabilities Excellent for pulp and paper, or liquor applications Process temperature: -58 to 350 °F (-50 to 177 °C)
PTFE 	Highly chemical resistant Excellent high temperature capabilities Process temperature: -58 to 350 °F (-50 to 177 °C)
Polyurethane 	Limited chemical resistance Excellent abrasion resistance for slurries with small and medium particles Process temperature: 0 to 140 °F (-18 to 60 °C) Typically applied in clean water
Neoprene 	Very good abrasion resistance for small and medium particles Better chemical resistance than polyurethane Typically applied in water with chemicals, and sea water Preferred liner for high pressure > ASME B16.5 Class 900 Process temperature: 0 to 176 °F (-18 to 80 °C)
Linatex rubber 	Limited chemical resistance especially in acids Very good abrasion resistance for large particles Softer material than polyurethane and neoprene Typically applied in mining slurries Process temperature: 0 to 158 °F (-18 to 70 °C)
Adiprene 	Ideal for applications with high salinity and/or hydrocarbon carryover Excellent abrasion resistance Typically used for Water Injection, Recovered Water, and Coal Gasification Slurries Preferred liner for high pressure > ASME B16.5 Class 900 Process temperature: 0 to 200 °F (-18 to 93 °C)

Table 15: Electrode material

Electrode material	General characteristics
316L Stainless steel	Good corrosion resistance
	Good abrasion resistance
	Not recommended for sulfuric or hydrochloric acids
Nickel alloy 276 (UNS N10276)	Better corrosion resistance
	High strength
	Good in slurry applications
	Effective in oxidizing fluids
Tantalum	Excellent corrosion resistance
	Not recommended for hydrofluoric acid, fluorosilic acid, or sodium hydroxide
80% platinum 20% iridium	Best chemical resistance
	Expensive material
	Not recommended for aquaregia
Titanium	Improved chemical resistance
	Improved abrasion resistance
	Good for sea water applications
	Not recommended for hydrofluoric or sulfuric acid
Tungsten carbide coated	Limited chemical resistance
	Best abrasion resistance
	High concentration slurries
	Preferred electrode for oil and gas fracturing applications

Table 16: Electrode type

Electrode type	General characteristics
Standard measurement	Lowest cost
	Good for most applications
Measurement + reference electrode (Also see and Table 17 for grounding options and installation	Low cost grounding option especially for large line sizes
	Minimum conductivity of 100 microSiemens/cm
	Not recommended for electrolytic or galvanic corrosion applications; not recommended for plastic or non-metallic piping
Bulletonose	Extended head protrudes into the flow stream for self-cleaning
	Best option for coating processes
Flat head	Low profile head
	Best option for abrasive slurries

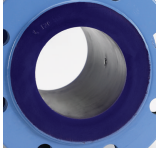
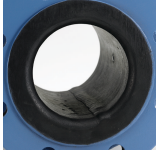
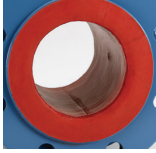
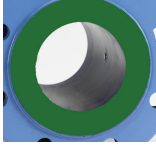
Table 17: Process reference options

Grounding options	General characteristics
Grounding straps (no grounding options selected).	Acceptable for conductive unlined pipe
	Grounding straps provided at no cost
Reference electrode	Same material as measurement electrodes
	Sufficient grounding option when process fluid conductivity is greater than 100 microSiemens/cm
	Not recommended in electrolysis applications, galvanic corrosion applications, applications where the electrodes may coat, or non-conductive pipe.
Grounding rings	Low conductivity process fluids
	Cathodic or electrolysis applications that may have stray currents in or around the process
	Variety of materials for process fluid compatibility
Lining protectors	Protect upstream edge of sensor from abrasive fluids
	Permanently installed on sensor
	Protect liner material from over torquing of flange bolts in many cases
	Provide process reference ground path and eliminate need for grounding rings or reference electrode
	Required for applications where Flexitallic gaskets are used

Table 18: Process reference installation

Type of pipe	Grounding straps	Grounding rings	Reference electrode	Lining protectors
Conductive unlined pipe	Acceptable	Not required	Not required	Not required
Conductive lined pipe	Not acceptable	Acceptable	Acceptable	Acceptable
Non-conductive pipe	Not acceptable	Acceptable	Not recommended	Acceptable

Transmitter specifications

Transmitter functional specifications

Transmitter coil drive current

For use with Rosemount MS and 8707 sensors only.

Flow rate range

Capable of processing signals from fluids with velocities between 0.04 ft/s and 39 ft/s (0.01 m/s and 12 m/s) for both forward and reverse flow in all sensor sizes. Full scale continuously adjustable between -39 ft/s and 39 ft/s (-12 m/s and 12 m/s).

Conductivity limits

Process liquid must have a conductivity of 50 microSiemens/cm or greater. Consult an Emerson Flow representative (see back page), for conductivity less than 50 microSiemens/cm.

Power supply

- 90 VAC to 250 VAC @ 50/60Hz.
 - Overvoltage Category II
 - Single Phase Earthed Neutral System
- 12 VDC to 42 VDC.

Note

For applications with sensors greater than 14 inch (350 mm) and process temperature greater than 212 °F (100 °C), consult an Emerson Flow representative (see back page) when applying less than 18 VDC to power terminals.

Line power fuses

Power supply type	Rating	Manufacturer part number
90–250 VAC	2.5 A, 250 VAC	Bel Fuse 3AG 2.5-R, Littlefuse 312025, or equivalent
12–42 VDC	12 A, 250 VAC	Bel Fuse 3AB 12-R, Littlefuse 314012, or equivalent

Power consumption

- 90 VAC to 250 VAC: 120 VA maximum
- 12 VDC to 42 VDC: 120 W maximum

Inrush/Start-up current

The power system must be capable of supporting inrush/start-up currents of:

- AC supply: Maximum 7 A (<5 ms)
- DC supply: Maximum 13 A (<5 ms)

AC power supply requirements

Units powered by 90 VAC to 250 VAC have the following power requirements. Peak inrush is 7 A at 250 VAC supply, lasting approximately 1 ms.

Figure 2: AC current requirements

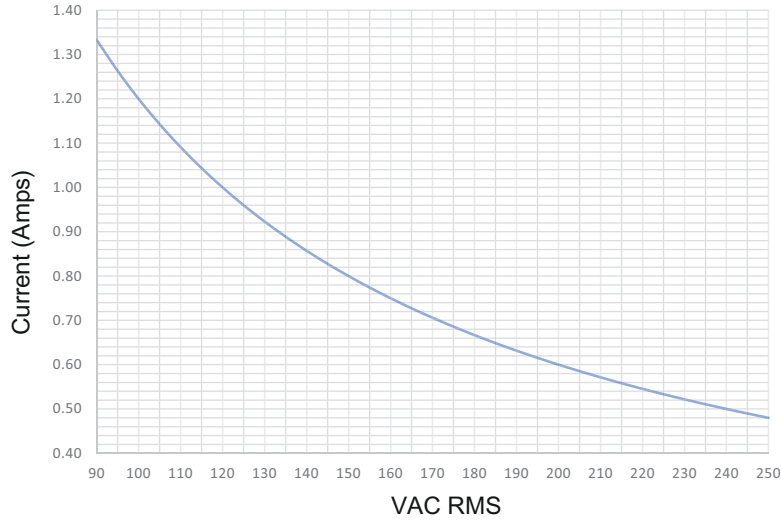

DC power supply requirements

Units powered by 12 VDC power supply may draw up to 8.6 A of current steady state. Peak inrush is 13 A at 12 VDC supply, lasting approximately 1 ms.

Figure 3: DC current requirements

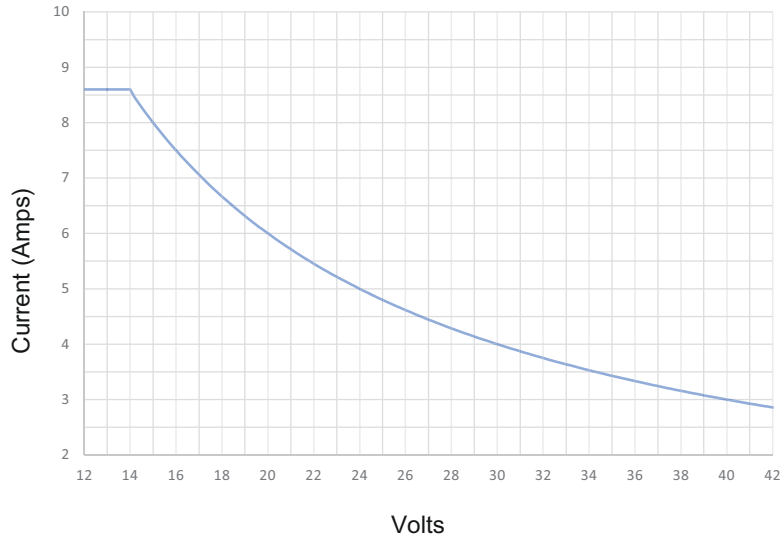

- A. Supply current (amps)
- B. Power supply (VDC)

Ambient temperature limits

- Operating:
 - –40 to 140°F (–40 to 60°C) without LOI/Display
 - –4 to 140°F (–20 to 60°C) with LOI/Display. The LOI/Display will not be visible at temperatures below –4°F (–20°C)
- Storage:
 - –58 to 185 °F (–50 to 85°C) without LOI/Display
 - –22 to 176°F (–30 to 80°C) with LOI/Display

Humidity limits

0 to 95% RH to 140°F (60°C)

Altitude

- 13,123 ft (4000 m) at rated input power voltage (90–250 VAC)
- 16,404 ft (5000 m) at maximum input power voltage of 150 VAC

Enclosure rating

Type 4X, IEC 60529, IP66, IP69 (transmitter)

Note

In order to achieve the rated Ingress Protections levels, the appropriately rated cable glands, conduit connections, and/or conduit plugs shall be used.

Transient protection rating

Built in transient protection that conforms to:

- IEC 61000-4-4 for burst voltages
- IEC 61000-4-5 for surge voltages and currents

Turn-on time

- 5 minutes to rated accuracy from power up
- 10 seconds from power interruption

Low flow cut-off

Adjustable between 0.01 and 38.37 ft/s (0.003 and 11.7 m/s). Below selected value, output is driven to the zero flow rate signal level.

Overrange capability

Signal output will remain linear until 110% of upper range value or 44 ft/s (13 m/s). The signal output will remain constant above these values. Out of range message displayed on LOI/Display and the Field Communicator.

Damping

Adjustable between 0 and 256 seconds

Advanced diagnostics capabilities

Basic

- Grounding and Wiring fault
- Empty Pipe
- Reverse Flow
- Electrode Saturation
- Transmitter Fault
- Electronics Temperature
- Coil Circuit Fault

Process diagnostics (DS1)

- High process noise
- Electrode coating diagnostic

Smart Meter Verification (MV)

- Smart Meter Verification Professional (continuous or on-demand)
- 4-20mA loop verification

Output signals

Analog output adjustment ⁽¹⁾

4–20mA, switch-selectable as internally or externally powered.

(1) For transmitters with intrinsically safe outputs (option code B), power must be supplied externally.

Analog loop load limitations

- Internally powered 24VDC max, 500 ohms max loop resistance
- Externally powered 10.8 - 30VDC max.
- Loop resistance is determined by the voltage level of the external power supply at the transmitter terminals:

Figure 4: Analog loop load limitations

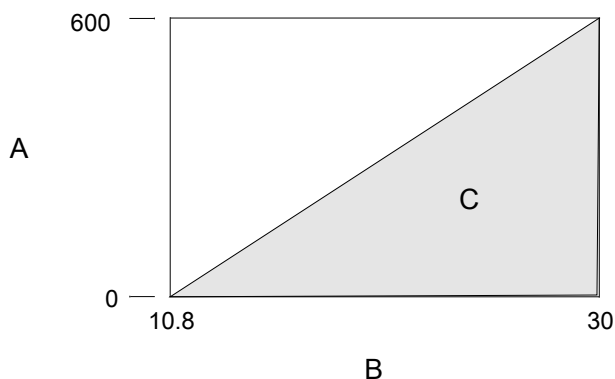

- A. Load (ohms)
- B. Power supply (volts)
- C. Operating region

- $R_{max} = 31.25 (V_{ps} - 10.8)$
- V_{ps} = power supply voltage (volts)
- R_{max} = maximum loop resistance (ohms)

The analog output is automatically scaled to provide 4mA at lower range value and 20mA at upper range value. Full scale continuously adjustable between -39 and 39 ft/s (-12 to 12 m/sec), 1 ft/s (0.3 m/s) minimum span.

HART Communications is a digital flow signal. The digital signal is superimposed on the 4–20mA signal and is available for the control system interface. A minimum of 250 ohms loop resistance is required for HART communications.

Analog alarm mode

High or low alarm signal is user-selectable via the Alarm switch on the front of the electronics. NAMUR-compliant alarm limits are software configurable and can be preset via CDS (C1). Individual diagnostic alarms are also software configurable. Alarms will drive the analog signal to the following mA values.

Low	3.75 mA	Requires CDS (C1)
High	22.50 mA	Factory default
NAMUR Low	3.5 mA	Requires CDS (C1)
NAMUR High	22.6 mA	Requires CDS (C1)

Scalable pulse frequency adjustment

- 0-10,000Hz, switch-selectable as internally or externally powered ⁽²⁾
- Pulse value can be set to equal desired volume in selected engineering units
- Pulse width adjustable from 0.1 to 650 ms
- Internally powered: Outputs up to 12VDC⁽³⁾
- Externally powered: Input 5 - 28VDC

Output testing

Analog output test ⁽³⁾ Transmitter may be commanded to supply a specified current between 3.5 and 23mA.

Pulse output test Transmitter may be commanded to supply a specified frequency between 1 and 10,000Hz.⁽²⁾

Security lockout

Security lockout switch on the electronics board can be set to deactivate all LOI and HART-based communicator functions to protect configuration variables from unwanted or accidental change.

Sensor compensation

Rosemount sensors are calibrated in a flow lab at the factory and are assigned a calibration number. The calibration number must be entered into the transmitter, enabling interchangeability of sensors without calculations or a compromise in standard accuracy.

Performance specifications

System specifications are given using the frequency output and with the unit at reference conditions.

Accuracy

Includes the combined effects of linearity, hysteresis, and repeatability.

(2) For transmitters with intrinsically safe outputs (option code B), frequency range is limited to 0-5000Hz and must be powered externally.

(3) For transmitters with intrinsically safe outputs (option code B), power must be supplied externally.

- Standard system accuracy:
 - $\pm 0.25\%$ of rate ± 1.0 mm/sec from 0.04 to 6 ft/s (0.01 to 2 m/s)
 - $\pm 0.25\%$ of rate ± 1.5 mm/sec above 6 ft/s (2 m/s)
- Optional high accuracy:⁽⁴⁾
 - $\pm 0.15\%$ of rate ± 1.0 mm/sec from 0.04 to 13 ft/s (0.01 to 4 m/s)
 - $\pm 0.18\%$ of rate above 13 ft/s (4 m/s)

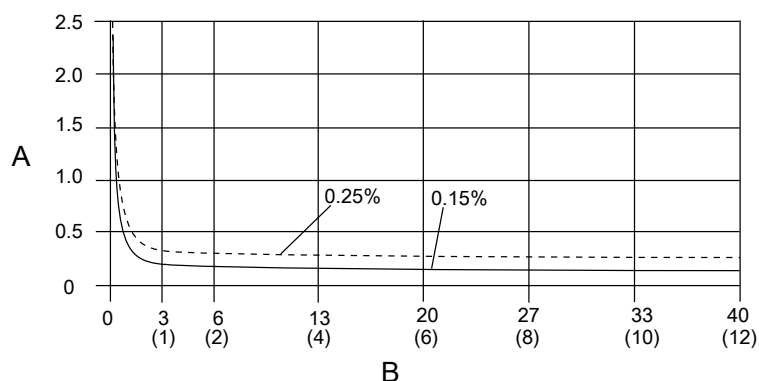

A. Percentage of rate
B. Velocity in ft/s (m/s)

Additional transmitter performance effects

Repeatability	$\pm 0.1\%$ of rate
Stability	$\pm 0.1\%$ of rate over six months
Ambient temperature effect	$\pm 0.25\%$ of rate change over operating temperature range
Analog output effect	$\pm 0.025\%$ of span

Analog output response

20 ms max response time to step change input.

8782 transmitter physical specifications

Materials of construction

Housing	Low copper aluminum Type 4X and IEC 60529 IP66, IP69
Paint	Polyurethane coat (1.8 to 2.2 mils thick)
Cover gaskets	Silicone

Electrical connections

Conduit entries	$\frac{1}{2}$ –14 NPT or M20–1.5 ⁽¹⁾
Terminal block screws	6-32 (No. 6) suitable for up to 14 AWG wire

(4) For sensor sizes greater than 12 in. (300 mm) the high accuracy is $\pm 0.25\%$ of rate from 3 to 39 ft/sec (1 to 12 m/sec).

Safety grounding screws	External stainless assembly, M5; internal 8-32 (No. 8)
-------------------------	--

(1) M20–1.5 connections provided with an adapter.

Vibration rating

2G per IEC 61298

Dimensions

See [Figure 5](#).

Weight

Wall mount transmitter	Approximately 11 lbs. (5 kg)
------------------------	------------------------------

Add 1 pound (0.5 kg) for LOI/Display.

MS Sensor Specifications



Functional specifications

Service

Conductive liquids and slurries

Line sizes

3 inch to 36 inch (80 mm to 900 mm)

Sensor coil resistance

2 - 20 Ω

Interchangeability

System accuracy is maintained regardless of line size or optional features. Each sensor nameplate has a sixteen-digit calibration number that can be entered into a transmitter during configuration.

Upper range limit

39.37 ft/s (12 m/s)

Ambient temperature limits

- -20 to 140 °F (-29 to 60 °C) standard design
- -58 to 140 °F (-50 to 60 °C) with "SH" all stainless design⁽⁵⁾

Pressure limits

See [Process temperature limits](#).

Vacuum limits

PTFE lining	Full vacuum to +350 °F (+177 °C) through 4-in. (100 mm) line sizes. Consult an Emerson Flow representative (see back page) for vacuum applications with line sizes of 6 inches (150 mm) or larger
All other standard sensor lining materials	Full vacuum to maximum material temperature limits for all available line sizes.

Submergence protection IP68

The remote mount sensor is rated IP68 for submergence to a depth of 33 ft (10 m) for a period of 48 hours. IP68 rating requires that the transmitter must be remote mount. Installer must use IP68 approved cable glands, conduit connections, and/or conduit plugs.

Conductivity limits

Process liquid must have a conductivity of 50 microSiemens/cm or greater. Consult an Emerson Flow representative (see back page), for conductivity less than 50 microSiemens/cm.

(5) Not available for Class/Div approval code N5.

Process temperature limits

PTFE lining	-58 to +350 °F (-50 to +177 °C)
PFA and PFA+ lining	-58 to +350 °F (-50 to +177 °C)
Polyurethane lining	0 to +140 °F (-18 to +60 °C)
Neoprene lining	0 to +176 °F (-18 to +80 °C)
Linatex lining	0 to +158 °F (-18 to +70 °C)
Adiprene lining	0 to +200 °F (-18 to +93 °C)

Note

Sensors ordered with hazardous location ratings may have different maximum process temperature limits. The sensors must be installed and used as directed by the installation drawing number noted on the serial nameplate.

Table 19: Temperature vs. Pressure Limits for ASME B16.5 class flanges ⁽¹⁾

Sensor temperature vs. pressure limits for ASME B16.5 class flanges					
Flange material	Flange rating	Pressure			
		@ -20 to 100 °F (-29 to 38 °C)	@ 200 °F (93 °C)	@ 300 °F (149 °C)	@ 350 °F (177 °C)
Carbon Steel	Class 150	285 psi	260 psi	230 psi	215 psi
	Class 300	740 psi	675 psi	655 psi	645 psi
	Class 600 ⁽²⁾	1000 psi	800 psi	700 psi	650 psi
	Class 600 ⁽³⁾	1480 psi	1350 psi	1315 psi	1292 psi
	Class 900	2220 psi	2025 psi	1970 psi	1935 psi
	Class 1500	3705 psi	3375 psi	3280 psi	3225 psi
	Class 2500	6170 psi	5625 psi	5470 psi	5375 psi
304 Stainless Steel	Class 150	275 psi	235 psi	205 psi	190 psi
	Class 300	720 psi	600 psi	530 psi	500 psi
	Class 600 ⁽²⁾	1000 psi	800 psi	700 psi	650 psi
	Class 600 ⁽³⁾	1440 psi	1200 psi	1055 psi	997 psi
	Class 900	2160 psi	1800 psi	1585 psi	1497 psi
	Class 1500	3600 psi	3000 psi	2640 psi	2495 psi
	Class 2500	6000 psi	5000 psi	4400 psi	4160 psi

(1) Liner temperature limits must also be considered.

(2) Flange rating Code 6.

(3) Flange rating Code 7.

Table 20: Temperature vs. Pressure Limits for AS2129 Table D and E flanges ⁽¹⁾

Sensor temperature vs. pressure limits for AS2129 Table D and E flanges (4 inch to 24 inch line sizes)					
Flange Material	Flange Rating	Pressure			
		@ -29 to 50 °C (-20 to 122 °F)	@ 100 °C (212 °F)	@ 150 °C (302 °F)	@ 200 °C (392 °F)
Carbon Steel	D	101.6 psi	101.6 psi	101.6 psi	94.3 psi
	E	203.1 psi	203.1 psi	203.1 psi	188.6 psi

(1) *Liner temperature limits must also be considered.*

Table 21: Temperature vs. Pressure Limits for EN 1092-1 flanges ⁽¹⁾

Sensor temperature vs. pressure limits for EN 1092-1 flanges (15 mm to 600 mm Line Sizes)					
Flange material	Flange rating	Pressure			
		@ -29 to 50 °C (-20 to 122 °F)	@ 100 °C (212 °F)	@ 150 °C (302 °F)	@ 175 °C (347 °F)
Carbon Steel	PN 10	10 bar	10 bar	9.7 bar	9.5 bar
	PN 16	16 bar	16 bar	15.6 bar	15.3 bar
	PN 25	25 bar	25 bar	24.4 bar	24.0 bar
	PN 40	40 bar	40 bar	39.1 bar	38.5 bar
304 Stainless Steel	PN 10	9.1 bar	7.5 bar	6.8 bar	6.5 bar
	PN 16	14.7 bar	12.1 bar	11.0 bar	10.6 bar
	PN 25	23 bar	18.9 bar	17.2 bar	16.6 bar
	PN 40	36.8 bar	30.3 bar	27.5 bar	26.5 bar

(1) *Liner temperature limits must also be considered.*

Table 22: Sensor Temperature vs. Pressure Limits for Grooved Coupling ⁽¹⁾

Sensor temperature vs. pressure limits for grooved coupling (3 inch to 10 inch line sizes)		
Flange Material	Line Size	Maximum Pressure @ -20 to 100 °F (-29 to 38 °C)
304 Stainless Steel	3 inch (80 mm)	500 psi (34 bar)
	4 inch (100 mm)	400 psi (27 bar)
	6 inch (150 mm)	400 psi (27 bar)
	8 inch (200 mm)	350 psi (24 bar)
	10 inch (250 mm)	800 psi (55 bar)

(1) *Customer must supply clamp and gasket that meets line pressure requirement, not to exceed pressures listed above.*

Physical specifications

Non-wetted materials

Sensor Pipe	Type 304/304L SST or Type 316/316L SST
Flanges	A105 Carbon steel, Type 304/304L SST, or Type 316/316L SST ⁽¹⁾
Coil housing	Rolled carbon steel or 300 series stainless steel
Paint	Polyurethane coat (2.6 mils or greater)

(1) *Ambient temperature low limit for A105 carbon steel is -20 °F (-29 °C) per ANSI B16.5. For colder ambient environments, stainless steel flanges must be used.*

Process-wetted materials

Lining	PTFE, Polyurethane, Neoprene, Linatex, Adiprene, PFA+
Electrodes	316L SST, Nickel Alloy 276 (UNS N10276), Tantalum, 80% Platinum-20% Iridium, Titanium

Flat-faced flanges

Sensors ordered with flat-faced flanges and Neoprene or Linatex liners are manufactured with the liner extending to the outer dimension of the flange. All other liner selections extend to the diameter of raised face dimension and create a raised surface on the flange face.

Process connections

ASME B16.5	<ul style="list-style-type: none"> ■ Class 150, Class 300, Class 600: 3 inch to 24 inch (80 mm to 600 mm) ■ Class 900: 3 inch to 20 inch (80 mm to 500 mm)⁽¹⁾ ■ Class 1500: 3 inch to 12 inch (80 mm to 300 mm)⁽¹⁾ ■ Class 2500: 3 inch to 8 inch (80 mm to 200 mm)
ASME B16.47 Series A	<ul style="list-style-type: none"> ■ Class 150 and Class 300: 30 inch to 36 inch (750 mm to 900 mm)
EN 1092-1	<ul style="list-style-type: none"> ■ PN10: 200 mm to 600 mm (8 inch to 24 inch), and 900 mm (36 inch) ■ PN16: 80 mm to 600 mm (3 inch to 24 inch), and 900 mm (36 inch) ■ PN25: 150 mm to 600 mm (6 inch to 24 inch) ■ PN40: 80 mm to 600 mm (3 inch to 24 inch)
AS2129	<ul style="list-style-type: none"> ■ Table D and Table E: 80 mm to 900 mm (3 inch to 36 inch)
AS4087	<ul style="list-style-type: none"> ■ PN16, PN21, PN35: 80 mm to 900 mm (3 inch to 36 inch)
JIS B2220	<ul style="list-style-type: none"> ■ 10K and 20K: 80 mm to 600 mm (3 inch to 24 inch) ■ 40K: 80 mm to 400 mm (3 inch to 16 inch)

(1) For Class 900 and higher flange ratings, liner selection is limited to resilient liners.

Electrical connections

Conduit entries	Available with ½ inch NPT and M20
Terminal block screws	6-32 (No. 6) suitable for up to 14 AWG wire
Safety grounding screws	External stainless assembly, M5; internal 8-32 (No. 8)

Process reference electrode (optional)

A process reference electrode can be installed similarly to the measurement electrodes through the sensor lining. It will be made of the same material as the measurement electrodes.

Grounding rings (optional)

Grounding rings can be installed between the flange and the sensor face on both ends of the sensor. Single ground rings can be installed on either end of the sensor. They have an I.D. slightly larger than the sensor I.D. and an external tab to attach ground straps. Grounding rings are available in 316L SST, Nickel Alloy 276 (UNS N10276), titanium, and tantalum. See [Ground rings](#).

Lining protectors (optional)

Lining protectors can be installed between the flange and the sensor face on both ends of the sensor. The leading edge of lining material is protected by the lining protector; lining protectors cannot be removed once they are installed. Lining protectors are available in 316L SST, Nickel Alloy 276 (UNS N10276), and titanium. See [Figure 4](#).

Dimensions

See [MS sensor dimensions](#).

Weight

Product weights are included in the dimensional tables, see [MS sensor dimensions](#).

8785 Reference Calibration Standard**Functional specifications****Ambient temperature limits**

- Operating: +40 °F to 104 °F (+5 °C to 40 °C)
- Storage: -40 °F to 140 °F (-40 °C to 60 °C)

Humidity Limits

0 to 95% relative humidity up to 13,000 ft (4000 m)

Performance specifications**Accuracy**

- $\pm 0.05\%$ of rate at 30 ft/s
- $\pm 0.10\%$ of rate at 10 ft/s and 3 ft/s

Warm-up Time

5 minutes minimum; 30 minutes for best accuracy

Ambient Temperature Effect

< 0.015% of rate per 10 °F (< 0.027% per 10 °C)

Humidity Effect

- No effect from 0 to 60% relative humidity
- < 0.10% of rate from 60 to 95% relative humidity

Physical specifications**Electrical connections**

Electrical connections are compatible with Model 8782 terminal blocks. Electrical connections are not compatible with other terminal blocks.

Orientation

Must be steady with all four feet firmly resting on a flat surface. Warm up time begins after the Calibration Standard is settled.

Materials of construction

Enclosure	Extruded aluminum and 316 stainless steel
Paint	Epoxy polyester

Weight

Approximately 10 lb (4.5 kg).

Product Certifications

For detailed approval certification information and installation drawings, please see the appropriate document listed below:

- Document number 00825-MA00-0009: *Rosemount 8782 and MS Approval Document - Class Division*
- Document number 00825-MA00-0010: *Rosemount 8782 and MS Approval Document - IECEx and ATEX*
- Document number 00825-MA00-0011: *Rosemount 8782 and MS Approval Document - North America Zone*
- Document number 00825-MA00-0012: *Rosemount 8785 Approval Document*
- Document number 00825-MA00-0013: *Rosemount 8782 and MS Approval Document - EAC EX*

Dimensional drawings

Wall mount transmitter dimensions

Figure 5: Wall mount transmitter dimensions

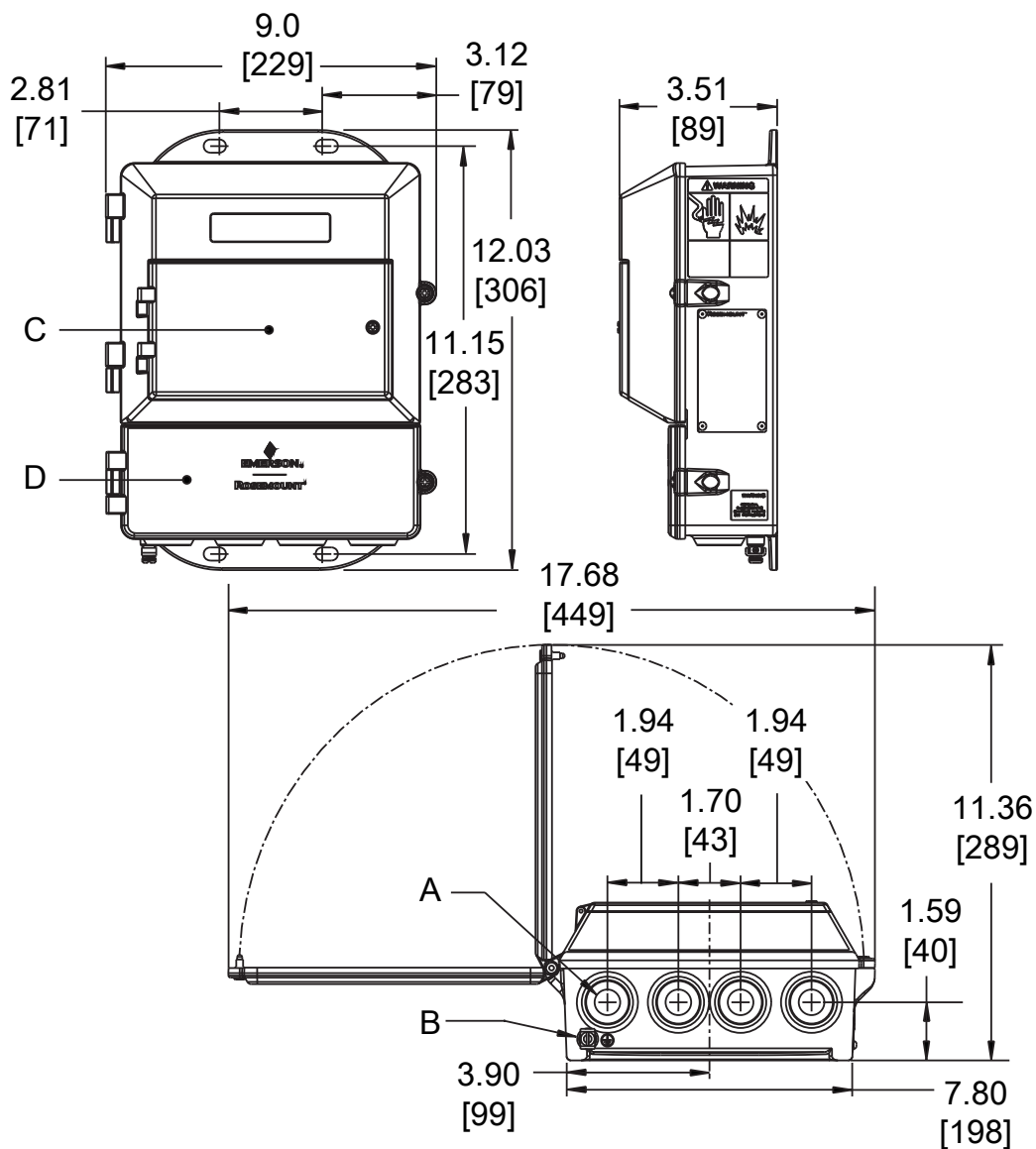

A. Conduit entry, 1/2-14 NPT (4 places)

B. Ground lug

C. LOI keypad cover

D. Lower cover opens for electrical connections

Note

Dimensions are in inches [Millimeters]

MS sensor dimensions

Housing style differentiation

Sensors ordered with Coil Housing Configuration M0 and Safety Approvals code NH (non-hazardous) use housing Style A; all other Coil Housing Configuration options and/or Safety Approvals codes use housing Style B. The two styles are differentiated in [Figure 6](#). The height of the sensor from the center of the pipe to the bottom of the junction box (Dim Ⓣ) varies based on the style, as indicated in the dimensional tables.

Figure 6: Housing Style A and Style B

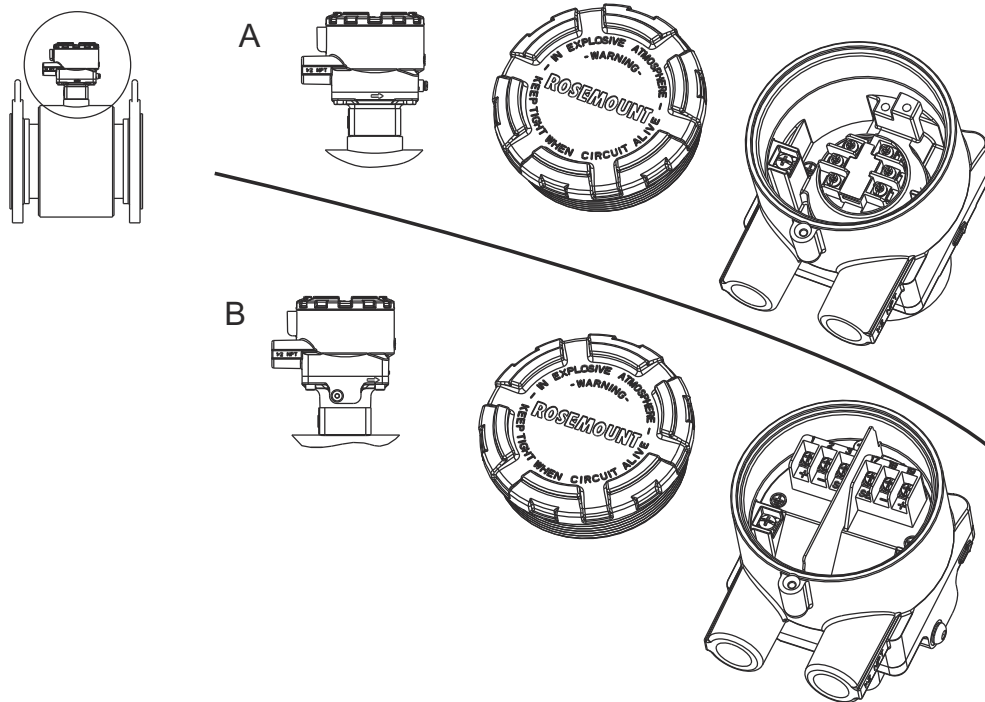

- A. Style A. Used with Coil Housing Configuration M0 and Safety Approvals code NH.
- B. Style B. Used with all other options.

Figure 7: Coil Housing Configuration M1 detail

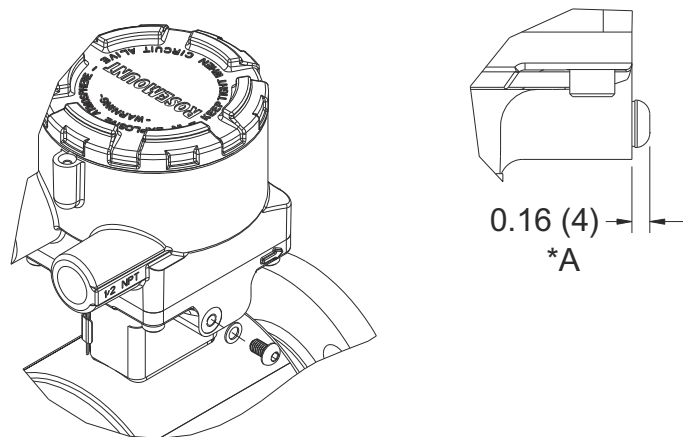

- A. Optional relief valve assembly is 1.75 inch (44.5 mm)

MS sensors with slip-on flanges

Figure 8: MS sensors with 3 inch to 36 inch slip-on flanges dimensional drawing

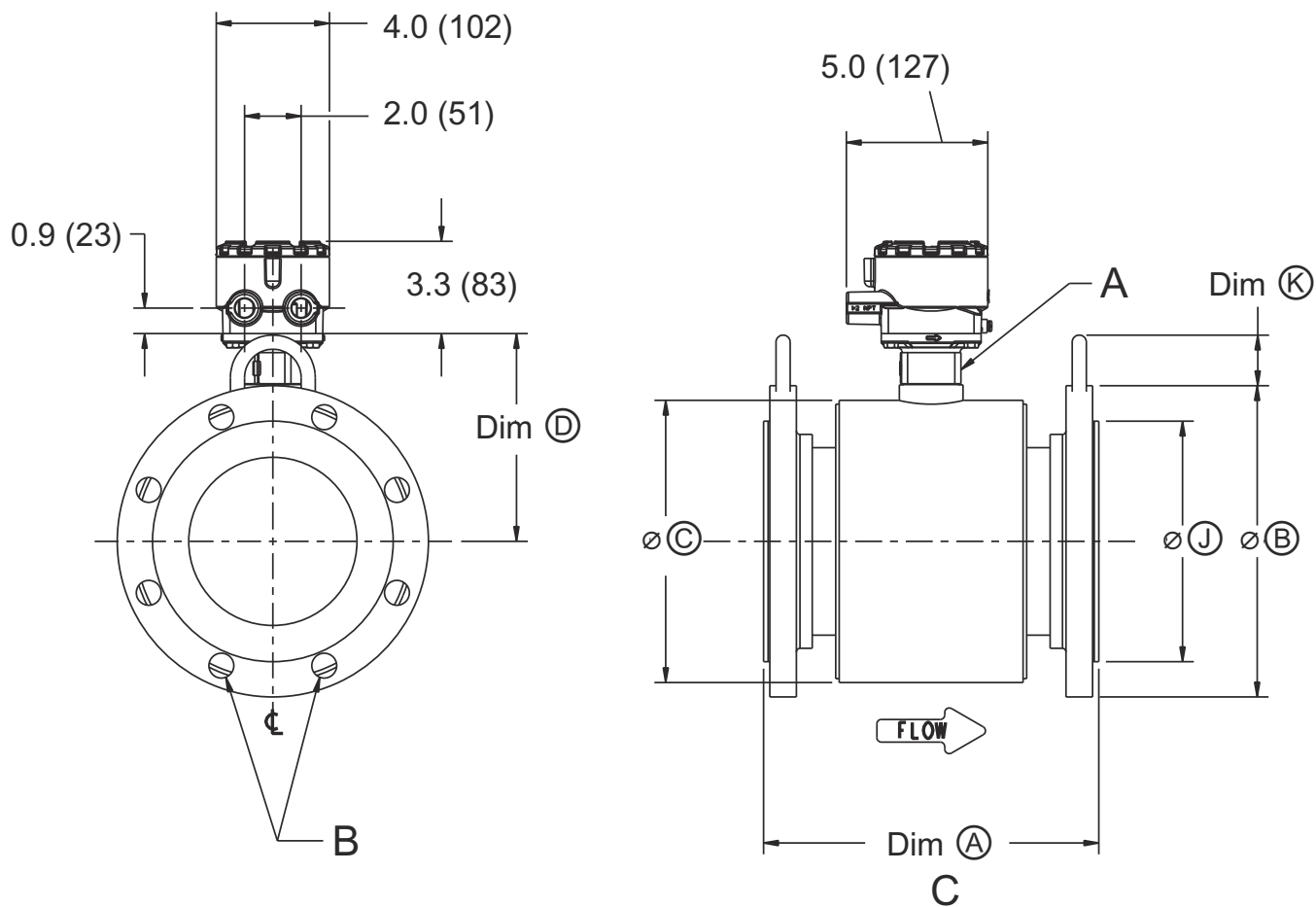

A. Nameplate

B. Flange bolts to straddle center line

C. Dim (A) with flat face flange is equal to that of a raised face flange. If using lining protectors, see [Lining protectors](#). If using ground rings, see [Ground rings](#).

Style A shown. See [Housing style differentiation](#).

See [Table 23](#) and [Table 24](#) for (A), (B), (C), (D), (J), and (K).

Table 23: MS sensors with 3 inch to 36 inch slip-on flanges dimensions in inches

Size, description	Overall length (Dim A)				ø B	ø C	Dim D		ø D	Dim E	Tube weight (lbs)	
	PTFE	Neoprene	Linatex	Poly			PFA/PFA+	Style A(1)				Style B(2)
3 inch (CL150)	7.87	7.75	7.84	7.87	7.83	7.50	7.21	5.82	5.97	5.00	1.70	34
3 inch (CL300)	8.63	8.51	8.60	8.63	8.60	8.25	7.21	5.82	5.97	5.00	1.70	43
3 inch (CL600), derated	12.40	12.29	12.39	12.40		8.25	7.21	5.82	5.97	5.00	1.70	53
3 inch (CL600)		12.16	12.16	12.16		8.25	7.21	5.82	5.97	4.63	1.70	51
3 inch (CL900)		12.79	12.79	12.79		9.50	7.21	5.82	5.97	4.63	1.70	72
3 inch EN 1092-1 - PN40	7.87	7.75	7.84	7.87	7.87	7.87	7.21	5.82	5.97	5.43	1.70	38
3 inch AS2129 TABLE D	7.87	7.75	7.84	7.87		7.28	7.21	5.82	5.97	4.80	1.70	24
3 inch AS2129 TABLE E	7.87	7.75	7.84	7.87		7.28	7.21	5.82	5.97	4.80	1.70	24
3 inch JIS B2220 - 10K	7.87	7.75	7.84	7.87		7.28	7.21	5.82	5.97	4.96	1.70	28
3 inch JIS B2220 - 20K	7.87	7.75	7.84	7.87		7.87	7.21	5.82	5.97	5.20	1.70	34
3 inch JIS B2220 - 40K	12.40	12.29	12.39	12.40		8.27	7.21	5.82	5.97	5.51	1.70	52
3 inch AS4087 PN16	7.87	7.75	7.84	7.87		7.28	7.21	5.82	5.97	4.80	1.70	20
3 inch AS4087 PN21	7.87	7.75	7.84	7.87		8.07	7.21	5.82	5.97	5.55	1.70	56
3 inch AS4087 PN35	7.87	7.75	7.84	7.87		8.07	7.21	5.82	5.97	5.55	1.70	109
4 inch (CL150)	9.84	9.69	9.78	9.84	9.84	9.00	7.91	6.17	6.32	6.19	1.70	45
4 inch (CL300)	10.88	10.73	10.82	10.88	10.88	10.00	7.91	6.17	6.32	6.19	1.70	65
4 inch (CL600), derated	12.83	12.70	12.79	12.83		10.75	7.91	6.17	6.32	6.19	1.70	94
4 inch (CL600)		12.56	12.56	12.56		10.75	7.91	6.17	6.32	5.81	1.70	90
4 inch (CL900)		13.86	13.86	13.86		11.50	7.91	6.17	6.32	5.81	2.00	120
4 inch EN 1092-1 - PN16	9.84	9.69	9.78	9.81	9.81	8.66	7.91	6.17	6.32	6.22	1.70	41
4 inch EN 1092-1 - PN40	9.84	9.69	9.78	9.81	9.81	9.25	7.91	6.17	6.32	6.38	1.70	49
4 inch AS2129 TABLE D	9.84	9.69	9.78	9.84		8.46	7.91	6.17	6.32	6.06	1.70	31
4 inch AS2129 TABLE E	9.84	9.69	9.78	9.84		8.46	7.91	6.17	6.32	6.06	1.70	33
4 inch JIS B2220 - 10K	9.84	9.69	9.78	9.84		8.27	7.91	6.17	6.32	5.95	1.70	35
4 inch JIS B2220 - 20K	9.84	9.69	9.78	9.84		8.86	7.91	6.17	6.32	6.30	1.70	44

Table 23: MS sensors with 3 inch to 36 inch slip-on flange dimensions in inches (continued)

Size, description	Overall length (Dim A)						ø B	ø C	Dim D		ø J	Dim K	Tube weight (lbs)
	PTFE	Neoprene	Linatex	Poly	PFA/PFA+	Style A(1)			Style B(2)				
4 inch JIS B2220 - 40K	12.83	12.70	12.79	12.83		9.84	7.91	6.17	6.32	6.50	1.70	75	
4 inch AS4087 PN16	9.84	9.69	9.78	9.84		8.46	7.91	6.17	6.32	6.06	1.70	28	
4 inch AS4087 PN21	9.84	9.69	9.78	9.84		9.06	7.91	6.17	6.32	6.57	1.70	68	
4 inch AS4087 PN35	9.84	9.69	9.78	9.84		9.06	7.91	6.17	6.32	6.57	1.70	119	
6 inch (CL150)	11.81	11.61	11.71	11.73	11.81	11.00	9.98	7.30	7.35	8.50	1.70	68	
6 inch (CL300)	13.06	12.88	12.97	13.00	13.06	12.50	9.98	7.30	7.35	8.50	1.70	117	
6 inch (CL600), derated	14.23	14.05	14.14	14.17		14.00	9.98	7.30	7.35	8.50	1.70	178	
6 inch (CL600)		13.92	13.92	13.92		14.00	9.98	7.30	7.35	8.00	1.70	184	
6 inch (CL900)		17.55	17.55	17.55		15.00	9.98	7.30	7.35	8.00	1.70	249	
6 inch EN 1092-1 - PN16	11.81	11.61	11.71	11.73	11.81	11.22	9.98	7.30	7.35	8.35	1.70	67	
6 inch EN 1092-1 - PN25	11.81	11.66	11.75	11.78	11.86	11.81	9.98	7.30	7.35	8.58	1.70	83	
6 inch EN 1092-1 - PN40	13.06	12.88	12.97	13.00	13.06	11.81	9.98	7.30	7.35	8.58	1.70	95	
6 inch AS2129 TABLE D	11.81	11.61	11.71	11.73		11.02	9.98	7.30	7.35	8.31	1.70	52	
6 inch AS2129 TABLE E	11.81	11.61	11.71	11.73		11.02	9.98	7.30	7.35	8.15	1.70	57	
6 inch JIS B2220 - 10K	11.81	11.61	11.71	11.73		11.02	9.98	7.30	7.35	8.35	1.70	64	
6 inch JIS B2220 - 20K	11.81	11.61	11.71	11.73		12.01	9.98	7.30	7.35	9.06	1.70	82	
6 inch JIS B2220 - 40K	14.23	14.05	14.14	14.17		13.98	9.98	7.30	7.35	9.45	1.70	161	
6 inch AS4087 PN16	11.81	11.61	11.71	11.73		11.02	9.98	7.30	7.35	8.31	1.70	46	
6 inch AS4087 PN21	11.81	11.61	11.71	11.73		12.01	9.98	7.30	7.35	9.13	1.70	98	
6 inch AS4087 PN35	11.81	11.61	11.71	11.73		12.01	9.98	7.30	7.35	9.13	1.70	186	
8 inch (CL150)	13.78	13.53	13.63	13.65	13.78	13.50	11.92	8.27	8.32	10.62	1.70	105	
8 inch (CL300)	15.60	15.42	15.51	15.54	15.60	15.00	11.92	8.27	8.32	10.62	1.70	183	
8 inch (CL600), derated	16.72	16.54	16.63	16.66		16.50	11.92	8.27	8.32	10.62	1.70	272	
8 inch (CL600)		16.44	16.44	16.44		16.50	11.92	8.27	8.32	10.00	1.70	285	
8 inch (CL900)		20.58	20.58	20.58		18.50	11.92	8.27	8.32	10.00	3.13	437	

Table 23: MS sensors with 3 inch to 36 inch slip-on flanges dimensions in inches (continued)

Size, description	Overall length (Dim A)					ø B	ø C	Dim D		ø J	Dim K	Tube weight (lbs)
	PTFE	Neoprene	Linatex	Poly	PFA/PFA+			Style A(1)	Style B(2)			
8 inch EN 1092-1 - PN10	13.78	13.53	13.63	13.65	13.78	13.39	11.92	8.27	8.32	10.55	1.70	97
8 inch EN 1092-1 - PN16	13.78	13.53	13.63	13.65	13.78	13.39	11.92	8.27	8.32	10.55	1.70	96
8 inch EN 1092-1 - PN25	13.78	13.53	13.63	13.65	13.78	14.17	11.92	8.27	8.32	10.94	1.70	120
8 inch EN 1092-1 - PN40	15.60	15.42	15.51	15.54	15.60	14.76	11.92	8.27	8.32	11.22	1.70	158
8 inch AS2129 TABLE D	13.78	13.53	13.63	13.65		13.19	11.92	8.27	8.32	10.55	1.70	77
8 inch AS2129 TABLE E	13.78	13.53	13.63	13.65		13.19	11.92	8.27	8.32	10.39	1.70	86
8 inch JIS B2220 - 10K	13.90	13.53	13.63	13.65		12.99	11.92	8.27	8.32	10.32	1.70	81
8 inch JIS B2220 - 20K	15.60	15.42	15.51	15.54		13.78	11.92	8.27	8.32	10.83	1.70	134
8 inch JIS B2220 - 40K	16.72	16.54	16.63	16.66		15.94	11.92	8.27	8.32	11.42	1.70	232
8 inch AS4087 PN16	13.78	13.53	13.63	13.65		13.19	11.92	8.27	8.32	10.55	1.70	73
8 inch AS4087 PN21	13.78	13.53	13.63	13.65		14.57	11.92	8.27	8.32	11.65	1.70	136
8 inch AS4087 PN35	15.60	15.42	15.51	15.54		14.57	11.92	8.27	8.32	10.24	1.70	241
10 inch (CL150)	15.00	14.63	14.73	14.75	15.00	16.00	14.64	9.69	9.68	12.75	2.00	152
10 inch (CL300)	17.13	16.86	16.95	16.95	17.13	17.50	14.64	9.69	9.68	12.75	2.00	267
10 inch (CL600), derated	19.54	19.34	19.43	19.46		20.00	14.64	9.69	9.68	12.75	2.00	462
10 inch (CL600)		19.05	19.05	19.05		20.00	14.64	9.69	9.68	12.00	2.00	467
10 inch (CL900)		21.54	21.54	21.54		21.50	14.64	9.69	9.68	12.00	3.13	641
10 inch EN 1092-1 - PN10	15.00	14.63	14.73	14.75	15.00	15.55	14.64	9.69	9.68	12.60	2.00	134
10 inch EN 1092-1 - PN16	15.00	14.63	14.73	14.75	15.00	15.94	14.64	9.69	9.68	12.60	2.00	138
10 inch EN 1092-1 - PN25	15.00	14.63	14.73	14.75	15.00	16.73	14.64	9.69	9.68	13.19	2.00	174
10 inch EN 1092-1 - PN40	17.13	16.86	16.95	16.98	17.13	17.72	14.64	9.69	9.68	13.58	2.00	244
10 inch AS2129 TABLE D	15.00	14.63	14.73	14.75		15.94	14.64	9.69	9.68	12.91	2.00	122
10 inch AS2129 TABLE E	15.00	14.63	14.73	14.75		15.94	14.64	9.69	9.68	12.91	2.00	137
10 inch JIS B2220 - 10K	15.00	14.63	14.73	14.75		15.75	14.64	9.69	9.68	12.76	1.70	129
10 inch JIS B2220 - 20K	17.13	16.86	16.95	16.98		16.93	14.64	9.69	9.68	13.58	1.70	218

Table 23: MS sensors with 3 inch to 36 inch slip-on flanges dimensions in inches (continued)

Size, description	Overall length (Dim A)					ø B	ø C	Dim D		ø J	Dim K	Tube weight (lbs)
	PTFE	Neoprene	Linatex	Poly	PFA/PFA+			Style A(1)	Style B(2)			
10 inch JIS B2220 - 40K	19.54	19.34	19.43			18.70	14.64	9.69	9.68	13.98	1.70	382
10 inch AS4087 PN16	15.00	14.63	14.73	14.75		15.94	14.64	9.69	9.68	12.91	2.00	96
10 inch AS4087 PN21	15.00	14.63	14.73	14.75		16.93	14.64	9.69	9.68	13.74	2.00	176
10 inch AS4087 PN35	17.13	16.86	16.95	16.98		16.93	14.64	9.69	9.68	12.24	2.00	299
12 inch (CL150)	18.01	17.68	17.78	17.80	18.00	19.00	16.80	10.77	10.76	15.00	2.00	231
12 inch (CL300)	20.14	19.80	19.89	19.92	20.14	20.50	16.80	10.77	10.76	15.00	2.00	387
12 inch (CL600), derated	22.08	21.88	21.98	22.00		22.00	16.80	10.77	10.76	15.00	2.00	623
12 inch (CL600)		21.75	21.75	21.75		22.00	16.80	10.77	10.76	14.00	2.00	607
12 inch (CL900)		25.15	25.15	25.15		24.00	16.80	10.77	10.76	14.00	3.13	893
12 inch EN 1092-1 PN10	18.01	17.68	17.78	17.80	18.00	17.52	16.80	10.77	10.76	14.57	2.00	178
12 inch EN 1092-1 PN10	18.01	17.68	17.78	17.80	18.00	18.11	16.80	10.77	10.76	14.88	2.00	192
12 inch EN 1092-1 PN25	18.01	17.68	17.78	17.80	18.00	19.09	16.80	10.77	10.76	15.55	2.00	242
12 inch EN 1092-1 PN40	20.14	19.80	19.89	19.92	20.14	20.28	16.80	10.77	10.76	16.14	2.00	351
12 inch AS2129 TABLE D	18.01	17.68	17.78	17.80		17.91	16.80	10.77	10.76	14.88	2.00	172
12 inch AS2129 TABLE E	18.01	17.68	17.78	17.80		17.91	16.80	10.77	10.76	14.72	2.00	185
12 inch JIS B2220 - 10K	18.01	17.68	17.78	17.80		17.52	16.80	10.77	10.76	14.49	2.00	166
12 inch JIS B2220 - 20K	20.14	19.80	19.89	19.92		18.90	16.80	10.77	10.76	15.55	2.00	285
12 inch JIS B2220 - 40K	22.08	21.88	21.98	21.78		21.26	16.80	10.77	10.76	16.14	3.13	546
12 inch AS4087 PN16	18.01	17.68	17.78	17.80		17.91	16.80	10.77	10.76	14.88	2.00	138
12 inch AS4087 PN21	18.01	17.68	17.78	17.80		19.29	16.80	10.77	10.76	15.98	2.00	225
12 inch AS4087 PN35	20.14	19.80	19.89	19.92		19.29	16.80	10.77	10.76	14.25	2.00	370
14 inch (CL150)	20.91	20.71	20.80	20.83	21.00	21.00	18.92	11.83	11.82	16.25	2.00	300
14 inch (CL300)	23.16	22.96	23.05	23.08		23.00	18.92	11.83	11.82	16.25	2.00	517
14 inch (CL600), derated	25.74					23.75	18.92	11.83	11.82	16.25	2.00	773
14 inch (CL600)		25.41	25.41	25.41		23.75	18.92	11.83	11.82	15.25	2.00	756

Table 23: MS sensors with 3 inch to 36 inch slip-on flange dimensions in inches (continued)

Size, description	Overall length (Dim A)				ø B	ø C	Dim D		ø U	Dim K	Tube weight (lbs)
	PTFE	Neoprene	Linatex	Poly			PFA/PFA+	Style A(1)			
14 inch (CL900)			33.89	33.85	25.25	18.92	11.83	11.82	15.13	2.00	1164
14 inch EN 1092-1 - PN10	20.91	20.71	20.80	20.83	19.88	18.92	11.83	11.82	16.93	2.00	252
14 inch EN 1092-1 - PN16	20.91	20.71	20.80	20.83	20.47	18.92	11.83	11.82	17.24	2.00	276
14 inch EN 1092-1 - PN25	20.91	20.71	20.80	20.83	21.85	18.92	11.83	11.82	17.72	2.00	359
14 inch EN 1092-1 - PN40	23.16	22.96	23.05	23.08	22.83	18.92	11.83	11.82	18.31	2.00	480
14 inch AS2129 TABLE D	20.91	20.71	20.80	20.83	20.67	18.92	11.83	11.82	17.24	2.00	230
14 inch AS2129 TABLE E	20.91	20.71	20.80	20.83	20.67	18.92	11.83	11.82	17.24	2.00	257
14 inch JIS B2220 - 10K	20.91	20.71	20.80	20.83	19.29	18.92	11.83	11.82	16.26	2.00	221
14 inch JIS B2220 - 20K	23.16	22.96	23.05	23.08	21.26	18.92	11.83	11.82	17.32	2.00	385
14 inch JIS B2220 - 40K	25.74	25.54	25.64		23.03	18.92	11.83	11.82	17.91	2.00	702
14 inch AS4087 PN16	20.91	20.71	20.80	20.83	20.67	18.92	11.83	11.82	17.24	2.00	219
14 inch AS4087 PN21	20.91	20.71	20.80	20.83	21.65	18.92	11.83	11.82	18.07	2.00	294
14 inch AS4087 PN35	23.16	22.96	23.05	23.08	21.65	18.92	11.83	11.82	16.50	2.00	497
16 inch (CL150)	23.88	23.68	23.77	23.80	23.50	20.94	12.84	12.83	18.50	3.13	388
16 inch (CL300)	26.13	25.93	26.02	26.05	25.50	20.94	12.84	12.83	18.50	3.13	705
16 inch (CL600), derated	29.24				27.00	20.94	12.84	12.83	18.50	3.13	1102
16 inch (CL600)		28.91	28.91	28.91	27.00	20.94	12.84	12.83	17.50	3.13	1080
16 inch (CL900)			36.89	36.85	27.75	20.94	12.84	12.83	17.38	3.13	1436
16 inch EN 1092-1 - PN10	23.88	23.68	23.77	23.80	22.24	20.94	12.84	12.83	18.98	3.13	318
16 inch EN 1092-1 - PN16	23.88	23.68	23.77	23.80	22.83	20.94	12.84	12.83	19.28	3.13	354
16 inch EN 1092-1 - PN25	26.13	25.93	26.02	26.05	24.41	20.94	12.84	12.83	19.88	3.13	581
16 inch EN 1092-1 - PN40	26.13	25.93	26.02	26.05	25.98	20.94	12.84	12.83	21.06	3.13	696
16 inch AS2129 TABLE D	23.88	23.68	23.77	23.80	22.83	20.94	12.84	12.83	19.25	3.13	283
16 inch AS2129 TABLE E	23.88	23.68	23.77	23.80	22.83	20.94	12.84	12.83	19.25	3.13	327
16 inch JIS B2220 - 10K	23.88	23.68	23.77	23.80	22.05	20.94	12.84	12.83	18.70	2.00	296

Table 23: MS sensors with 3 inch to 36 inch slip-on flanges dimensions in inches (continued)

Size, description	Overall length (Dim A)					ø B	ø C	Dim D		ø J	Dim K	Tube weight (lbs)
	PTFE	Neoprene	Linatex	Poly	PFA/PFA+			Style A(1)	Style B(2)			
16 inch JIS B2220 - 20K	26.13	25.93	26.02	26.05		23.82	20.94	12.84	12.83	19.49	2.00	561
16 inch JIS B2220 - 40K	29.24	29.04	29.14			25.39	20.94	12.84	12.83	20.28	2.00	961
16 inch AS4087 PN16	23.88	23.68	23.77	23.80		22.83	20.94	12.84	12.83	19.25	3.13	292
16 inch AS4087 PN21	23.88	23.68	23.77	23.80		24.02	20.94	12.84	12.83	20.31	3.13	387
16 inch AS4087 PN35	26.13	25.93	26.02	26.05		24.02	20.94	12.84	12.83	19.02	3.13	631
18 inch (CL150)	26.85	26.65	26.74	26.77		25.00	23.46	14.10	14.09	21.00	3.13	451
18 inch (CL300)	29.97	29.77	29.86	29.89		28.00	23.46	14.10	14.09	21.00	3.13	907
18 inch (CL600), derated	32.72					29.25	23.46	14.10	14.09	21.00	3.13	1407
18 inch (CL600)		32.39	32.39	32.39		29.25	23.46	14.10	14.09	20.00	3.13	1378
18 inch (CL900)			38.89	38.85		31.00	23.46	14.10	14.09	19.88	3.13	1877
18 inch EN 1092-1 - PN10	26.85	26.65	26.74	26.77		24.21	23.46	14.10	14.09	20.94	3.13	381
18 inch EN 1092-1 - PN16	26.85	26.65	26.74	26.77		25.20	23.46	14.10	14.09	21.65	3.13	434
18 inch EN 1092-1 - PN25	29.97	29.77	29.86	29.89		26.38	23.46	14.10	14.09	21.85	3.13	744
18 inch EN 1092-1 - PN40	29.97	26.65	29.86	29.89		26.97	23.46	14.10	14.09	22.05	3.13	817
18 inch AS2129 TABLE D	26.85	26.65	26.74	26.77		25.20	23.46	14.10	14.09	20.94	3.13	356
18 inch AS2129 TABLE E	26.85	26.65	26.74	26.77		25.20	23.46	14.10	14.09	21.73	3.13	414
18 inch JIS B2220 - 10K	26.85	26.65	26.74	26.77		24.41	23.46	14.10	14.09	20.87	3.13	373
18 inch JIS B2220 - 20K	29.97	29.77	29.86	29.89		26.57	23.46	14.10	14.09	22.05	3.13	751
18 inch AS4087 PN16	26.85	26.65	26.74	26.77		25.20	23.46	14.10	14.09	21.73	3.13	323
18 inch AS4087 PN21	26.85	26.65	26.74	26.77		26.57	23.46	14.10	14.09	22.48	3.13	453
18 inch AS4087 PN35	29.97	29.77	29.86	29.89		26.57	23.46	14.10	14.09	20.98	3.13	917
20 inch (CL150)	29.78	29.58	29.67	29.70		27.50	25.48	15.11	15.1	23.00	3.13	569
20 inch (CL300)	33.04	32.84	32.93	32.96		30.50	25.48	15.11	15.1	23.00	3.13	1127
20 inch (CL600), derated	36.85					32.00	25.48	15.11	15.1	23.00	3.13	1824
20 inch (CL600)		36.52	36.52	36.52		32.00	25.48	15.11	15.1	22.00	3.13	1790

Table 23: MS sensors with 3 inch to 36 inch slip-on flanges dimensions in inches (continued)

Size, description	Overall length (Dim A)				ø B	ø C	Dim D		ø J	Dim K	Tube weight (lbs)
	PTFE	Neoprene	Linatex	Poly			PFA/PFA+	Style A(1)			
20 inch (CL900)			41.89	41.85	33.75	25.48	15.11	15.1	21.88	3.13	2286
20 inch EN 1092-1 - PN10	29.78	29.58	29.67	29.70	26.38	25.48	15.11	15.1	23.03	3.13	473
20 inch EN 1092-1 - PN16	29.78	29.58	29.67	29.70	28.15	25.48	15.11	15.1	24.02	3.13	567
20 inch EN 1092-1 - PN25	33.04	32.84	32.93	32.96	28.74	25.48	15.11	15.1	24.21	3.13	932
20 inch EN 1092-1 - PN40	33.04	32.84	32.93	32.96	29.72	25.48	15.11	15.1	24.21	3.13	1013
20 inch AS2129 TABLE D	29.78	29.58	29.67	29.70	27.76	25.48	15.11	15.1	23.98	3.13	471
20 inch AS2129 TABLE E	29.78	29.58	29.67	29.70	27.76	25.48	15.11	15.1	23.98	3.13	528
20 inch JIS B2220 - 10K	29.78	29.58	29.67	29.70	26.57	25.48	15.11	15.1	23.03	3.13	453
20 inch JIS B2220 - 20K	33.04	32.84	32.93	32.96	28.74	25.48	15.11	15.1	24.21	3.13	919
20 inch AS4087 PN16	29.78	29.58	29.67	29.70	27.76	25.48	15.11	15.1	23.98	3.13	453
20 inch AS4087 PN21	29.78	29.58	29.67	29.70	28.94	25.48	15.11	15.1	24.96	3.13	627
20 inch AS4087 PN35	33.04	32.84	32.93	32.96	28.94	25.48	15.11	15.1	23.50	3.13	1074
24 inch (CL150)	35.75	35.55	35.64	35.67	32.00	30.03	17.39	17.38	27.25	3.13	828
24 inch (CL300)	39.38	39.18	39.27	39.30	36.00	30.03	17.39	17.38	27.25	3.13	1729
24 inch (CL600), derated	41.35				37.00	30.03	17.39	17.38	27.25	3.13	2690
24 inch		41.02	41.02	41.02	37.00	30.03	17.39	17.38	26.00	3.13	2648
24 inch EN 1092-1 - PN10	35.75	35.55	35.64	35.67	30.71	30.03	17.39	17.38	26.97	3.13	661
24 inch EN 1092-1 - PN16	35.75	35.55	35.64	35.67	33.07	30.03	17.39	17.38	28.54	3.13	832
24 inch EN 1092-1 - PN25	39.38	39.18	39.27	39.30	33.27	30.03	17.39	17.38	28.35	3.13	1352
24 inch EN 1092-1 - PN40	39.38	39.18	39.27	39.30	35.04	30.03	17.39	17.38	28.94	3.13	1628
24 inch AS2129 TABLE D	35.75	35.55	35.64	35.67	32.48	30.03	17.39	17.38	28.35	3.13	692
24 inch AS2129 TABLE E	35.75	35.55	35.64	35.67	32.48	30.03	17.39	17.38	28.23	3.13	814
24 inch JIS B2220 - 10K	35.75	35.55	35.64	35.67	31.30	30.03	17.39	17.38	27.17	3.13	659
24 inch JIS B2220 - 20K	39.38	39.18	39.27	39.30	33.27	30.03	17.39	17.38	28.35	3.13	1353
24 inch AS4087 PN16	35.75	35.55	35.64	35.67	32.48	30.03	17.39	17.38	28.35	3.13	709

Table 23: MS sensors with 3 inch to 36 inch slip-on flanges dimensions in inches (continued)

Size, description	Overall length (Dim A)					ø B	ø C	Dim D		ø J	Dim K	Tube weight (lbs)
	PTFE	Neoprene	Linatex	Poly	PFA/PFA+			Style A ⁽¹⁾	Style B ⁽²⁾			
24 inch AS4087 PN21	39.38	39.18	39.27	39.30		33.46	30.03	17.39	17.38	29.09	3.13	1293
24 inch AS4087 PN35	39.38	39.18	39.27	39.30		33.46	30.03	17.39	17.38	27.52	3.13	1528
30 inch MSS SP44 - 150#	41.56	41.36	41.45	41.48		38.75	35.50	20.13	20.11	33.75	3.13	1561
30 inch MSS SP44 - 300#	47.25	47.05	47.14	47.17		43.00	35.50	20.13	20.11	33.75	3.13	2950
30 inch AS2129 TABLE D	37.00	36.80	36.89	37.04		39.17	35.50	20.13	20.11	34.96	3.13	1036
30 inch AS2129 TABLE E	41.56	41.36	41.45	41.48		39.17	35.50	20.13	20.11	33.75	3.13	1275
30 inch AS4087 PN16	37.00	36.80	36.89	36.92		39.17	35.50	20.13	20.11	34.96	3.13	1083
30 inch AS4087 PN21	41.56	41.36	41.45	41.48		39.96	35.50	20.13	20.11	3.00	3.13	1071
30 inch AS4087 PN35	47.25	47.05	47.14	47.17		39.96	35.50	20.13	20.11	35.35	3.13	2452
36 inch MSS SP44 - 150#	47.25	47.05	47.14	47.17		46.00	43.37	24.00	24.05	40.25	3.13	2550
36 inch MSS SP44 - 300#	53.17	52.97	53.06	53.09		50.00	43.37	24.00	24.05	40.25	3.38	4584
36 inch AS2129 TABLE D	40.63	40.43	40.52	40.67		46.26	43.37	24.00	24.05	41.34	3.13	1515
36 inch AS2129 TABLE E	47.25	47.05	47.14	47.17		46.26	43.37	24.00	24.05	41.34	3.13	2105
36 inch AS4087 PN16	40.63	40.43	40.52	40.55		46.26	43.37	24.00	24.05	41.34	3.13	1559
36 inch AS4087 PN21	47.25	47.05	47.14	47.17		46.65	43.37	24.00	24.05	41.73	3.13	2060
36 inch AS4087 PN35	53.17	52.97	53.06	53.09		46.65	43.37	24.00	24.05	40.55	3.13	3700

(1) With approval code NH, but not dual seal (DS) models.

(2) With approval codes other than NH, and with dual seal (DS) models.

Table 24: MS sensors with 80 mm to 900 mm slip-on flanges dimensions in mm

Size, description	Overall length (Dim A)				ø B	ø C	Dim D		ø D	Dim E	Tube weight (kg)
	PTFE	Neoprene	Linatex	Poly			PFA/PFA+	Style A(1)			
80 mm (CL150)	200	197	199	200	199	183	148	152	127	43	15
80 mm (CL300)	219	216	219	219	218	183	148	152	127	43	19
80 mm (CL600), derated	315	312	315	315		183	148	152	127	43	24
80 mm (CL600)		309	309	309		183	148	152	118	43	23
80 mm (CL900)		325	325	325		183	148	152	118	43	33
80 mm EN 1092-1 - PN40	200	197	199	200	200	183	148	152	138	43	17
80 mm AS2129 TABLE D	200	197	199	200		183	148	152	122	43	11
80 mm AS2129 TABLE E	200	197	199	200		183	148	152	122	43	11
80 mm JIS B2220 - 10K	200	197	199	200		183	148	152	126	43	13
80 mm JIS B2220 - 20K	200	197	199	200		183	148	152	132	43	16
80 mm JIS B2220 - 40K	315	312	315	315		183	148	152	140	43	24
80 mm AS4087 PN16	200	197	199	200		183	148	152	122	43	9
80 mm AS4087 PN21	200	197	199	200		183	148	152	141	43	25
80 mm AS4087 PN35	200	197	199	200		183	148	152	141	43	49
100 mm (CL150)	250	246	249	250	250	201	157	152	157	43	20
100 mm (CL300)	276	273	275	276	276	201	157	160	157	43	29
100 mm (CL600), derated	326	323	325	326		201	157	160	157	43	42
100 mm (CL600)		319	319	319		201	157	160	148	43	51
100 mm (CL900)		352	352	352		201	157	160	148	51	54
100 mm EN 1092-1 - PN16	250	246	249	249	249	201	157	160	158	43	19
100 mm EN 1092-1 - PN40	250	246	249	249	249	201	157	160	162	43	22
100 mm AS2129 TABLE D	250	246	249	250		201	157	160	154	43	14
100 mm AS2129 TABLE E	250	246	249	250		201	157	160	154	43	15
100 mm JIS B2220 - 10K	250	246	249	250		201	157	160	151	43	16
100 mm JIS B2220 - 20K	250	246	249	250		201	157	160	160	43	20

Table 24: MS sensors with 80 mm to 900 mm slip-on flanges dimensions in mm (continued)

Size, description	Overall length (Dim A)				ø B	ø C	Dim D		ø D	Dim E	Tube weight (kg)
	PTFE	Neoprene	Linatex	Poly			PFA/PFA+	Style A(1)			
100 mm JIS B2220 - 40K	326	323	325	326		201	157	160	165	43	34
100 mm AS4087 PN16	250	246	249	250		215	157	160	154	43	13
100 mm AS4087 PN21	250	246	249	250		230	157	160	167	43	31
100 mm AS4087 PN35	250	246	249	250		230	157	160	167	43	54
150 mm (CL150)	300	295	297	298	300	279	185	187	216	43	31
150 mm (CL300)	332	327	330	330	332	318	185	187	216	43	53
150 mm (CL600), derated	361	357	359	360		356	185	187	216	43	81
150 mm (CL600)		353	353	353		356	185	187	203	43	84
150 mm (CL900)		446	446	446		381	185	187	203	51	113
150 mm EN 1092-1 PN16	300	295	297	298	300	285	185	187	212	43	31
150 mm EN 1092-1 PN25	300	296	299	299	301	300	185	187	218	43	38
150 mm EN 1092-1 PN40	332	327	330	330	332	300	185	187	218	43	43
150 mm AS2129 TABLE D	300	295	297	298		280	185	187	211	43	24
150 mm AS2129 TABLE E	300	295	297	298		280	185	187	207	43	26
150 mm JIS B2220 - 10K	300	295	297	298		280	185	187	212	43	29
150 mm JIS B2220 - 20K	300	295	297	298		305	185	187	230	43	37
150 mm JIS B2220 - 40K	361	357	359	360		355	185	187	240	43	73
150 mm AS4087 PN16	300	295	297	298		280	185	187	211	43	21
150 mm AS4087 PN21	300	295	297	298		305	185	187	232	43	45
150 mm AS4087 PN35	300	295	297	298		305	185	187	232	43	84
200 mm (CL150)	350	344	346	347	350	343	210	211	270	43	48
200 mm (CL300)	396	392	394	395	396	381	210	211	270	43	83
200 mm (CL600), derated	425	420	422	423		419	210	211	270	43	123
200 mm (CL600)		417	417	417		419	210	211	254	43	129
200 mm (CL900)		523	523	523		470	210	211	254	80	198

Table 24: MS sensors with 80 mm to 900 mm slip-on flanges dimensions in mm (continued)

Size, description	Overall length (Dim A)					ø B	ø C	Dim D		ø D	Dim E	Tube weight (kg)
	PTFE	Neoprene	Linatex	Poly	PFA/PFA+			Style A(1)	Style B(2)			
200 mm EN 1092-1 PN10	350	344	346	347	350	340	303	210	211	268	43	44
200 mm EN 1092-1 PN16	350	344	346	347	350	340	303	210	211	268	43	43
200 mm EN 1092-1 PN25	350	344	346	347	350	360	303	210	211	278	43	54
200 mm EN 1092-1 PN40	396	392	394	395	396	375	303	210	211	285	43	72
200 mm AS2129 TABLE D	350	344	346	347		335	303	210	211	268	43	35
200 mm AS2129 TABLE E	350	344	346	347		335	303	210	211	264	43	39
200 mm JIS B2220 - 10K	353	344	346	347		330	303	210	211	262	43	37
200 mm JIS B2220 - 20K	396	392	394	395		350	303	210	211	275	43	61
200 mm JIS B2220 - 40K	425	420	422	423		405	303	210	211	290	43	105
200 mm AS4087 PN16	350	344	346	347		335	303	210	211	268	43	33
200 mm AS4087 PN21	350	344	346	347		370	303	210	211	296	43	62
200 mm AS4087 PN35	396	392	394	395		370	303	210	211	260	43	109
250 mm (CL150)	381	372	374	375	381	406	372	246	246	324	51	69
250 mm (CL300)	435	428	431	431	435	445	372	246	246	324	51	121
250 mm (CL600), derated	496	491	494	494		508	372	246	246	324	51	210
250 mm (CL600)		484	484	484		508	372	246	246	305	51	212
250 mm (CL900)		547	547	547		546	372	246	246	305	80	291
250 mm EN 1092-1 PN10	381	372	374	375	381	395	372	246	246	320	51	61
250 mm EN 1092-1 PN16	381	372	374	375	381	405	372	246	246	320	51	63
250 mm EN 1092-1 PN25	381	372	374	375	381	425	372	246	246	335	51	79
250 mm EN 1092-1 PN40	435	428	431	431	435	450	372	246	246	345	51	111
250 mm AS2129 TABLE D	381	372	374	375		405	372	246	246	328	51	56
250 mm AS2129 TABLE E	381	372	374	375		405	372	246	246	328	51	62
250 mm JIS B2220 - 10K	381	372	374	375		400	372	246	246	324	43	59
250 mm JIS B2220 - 20K	435	428	431	431		430	372	246	246	345	43	99

Table 24: MS sensors with 80 mm to 900 mm slip-on flanges dimensions in mm (continued)

Size, description	Overall length (Dim A)					ø B	ø C	Dim D		ø D	Dim E	Tube weight (kg)
	PTFE	Neoprene	Linatex	Poly	PFA/PFA+			Style A(1)	Style B(2)			
250 mm JIS B2220 - 40K	496	491	494			475	372	246	246	355	43	174
250 mm AS4087 PN16	381	372	374	375		405	372	246	246	328	51	44
250 mm AS4087 PN21	381	372	374	375		430	372	246	246	349	51	80
250 mm AS4087 PN35	435	428	431	431		430	372	246	246	311	51	136
300 mm (CL150)	458	449	452	452	457	483	427	274	273	381	51	105
300 mm (CL300)	512	503	505	506	512	521	427	274	273	381	51	175
300 mm (CL600), derated	561	556	558	559		559	427	274	273	381	51	283
300 mm (CL600)		552	552	552		559	427	274	273	356	51	275
300 mm (CL900)		639	639	639		610	427	274	273	356	80	405
300 mm EN 1092-1 PN10	458	449	452	452	457	445	427	274	273	370	51	81
300 mm EN 1092-1 PN16	458	449	452	452	457	460	427	274	273	378	51	87
300 mm EN 1092-1 PN25	458	449	452	452	457	485	427	274	273	395	51	110
300 mm EN 1092-1 PN40	512	503	505	506	512	515	427	274	273	410	51	159
300 mm AS2129 TABLE D	458	449	452	452		455	427	274	273	378	51	78
300 mm AS2129 TABLE E	458	449	452	452		455	427	274	273	374	51	84
300 mm JIS B2220 - 10K	458	449	452	452		445	427	274	273	368	51	75
300 mm JIS B2220 - 20K	512	503	505	506		480	427	274	273	395	51	129
300 mm JIS B2220 - 40K	561	556	558	553		540	427	274	273	410	80	248
300 mm AS4087 PN16	458	449	452	452		455	427	274	273	378	51	63
300 mm AS4087 PN21	458	449	452	452		490	427	274	273	406	51	102
300 mm AS4087 PN35	512	503	505	506		490	427	274	273	362	51	168
350 mm (CL150)	531	526	528	529	533	533	481	300	300	413	51	136
350 mm (CL300)	588	583	586	586		584	481	300	300	413	51	234
350 mm (CL600), derated	654					603	481	300	300	413	51	351
350 mm (CL600)		645	645	645		603	481	300	300	387	51	343

Table 24: MS sensors with 80 mm to 900 mm slip-on flanges dimensions in mm (continued)

Size, description	Overall length (Dim A)					ø B	ø C	Dim D		ø D	Dim E	Tube weight (kg)
	PTFE	Neoprene	Linatex	Poly	PFA/PFA+			Style A(1)	Style B(2)			
350 mm (CL900)			861	860		641	481	300	300	384	51	528
350 mm EN 1092-1 PN10	531	526	528	529	533	505	481	300	300	430	51	114
350 mm EN 1092-1 PN16	531	526	528	529	533	520	481	300	300	438	51	125
350 mm EN 1092-1 PN25	531	526	528	529		555	481	300	300	450	51	163
350 mm EN 1092-1 PN40	588	583	586	586		580	481	300	300	465	51	218
350 mm AS2129 TABLE D	531	526	528	529		525	481	300	300	438	51	104
350 mm AS2129 TABLE E	531	526	528	529		525	481	300	300	438	51	116
350 mm JIS B2220 - 10K	531	526	528	529		490	481	300	300	413	51	100
350 mm JIS B2220 - 20K	588	583	586	586		540	481	300	300	440	51	175
350 mm JIS B2220 - 40K	654	649	651			585	481	300	300	455	51	318
350 mm AS4087 PN16	531	526	528	529		525	481	300	300	438	51	99
350 mm AS4087 PN21	531	526	528	529		550	481	300	300	459	51	133
350 mm AS4087 PN35	588	583	586	586		550	481	300	300	419	51	226
400 mm (CL150)	607	601	604	604		597	532	326	326	470	80	176
400 mm (CL300)	664	659	661	662		648	532	326	326	470	80	320
400 mm (CL600), derated	743					686	532	326	326	470	80	500
400 mm (CL600)		734	734	734		686	532	326	326	445	80	490
400 mm (CL900)			937	936		705	532	326	326	441	80	651
400 mm EN 1092-1 PN10	607	601	604	604		565	532	326	326	482	80	144
400 mm EN 1092-1 PN16	607	601	604	604		580	532	326	326	490	80	161
400 mm EN 1092-1 PN25	664	659	661	662		620	532	326	326	505	80	264
400 mm EN 1092-1 PN40	664	659	661	662		660	532	326	326	535	80	316
400 mm AS2129 TABLE D	607	601	604	604		580	532	326	326	489	80	129
400 mm AS2129 TABLE E	607	601	604	604		580	532	326	326	489	80	148
400 mm JIS B2220 - 10K	607	601	604	604		560	532	326	326	475	51	134

Table 24: MS sensors with 80 mm to 900 mm slip-on flanges dimensions in mm (continued)

Size, description	Overall length (Dim A)					ø B	ø C	Dim D		ø J	Dim K	Tube weight (kg)
	PTFE	Neoprene	Linatex	Poly	PFA/PFA+			Style A(1)	Style B(2)			
400 mm JIS B2220 - 20K	664	659	661	662		605	532	326	326	495	51	254
400 mm JIS B2220 - 40K	743	738	740			645	532	326	326	515	51	436
400 mm AS4087 PN16	607	601	604	604		580	532	326	326	489	80	119
400 mm AS4087 PN21	607	601	604	604		610	532	326	326	516	80	175
400 mm AS4087 PN35	664	659	661	662		610	532	326	326	483	80	286
450 mm (CL150)	682	677	679	680		635	596	358	358	533	80	205
450 mm (CL300)	761	756	758	759		711	596	358	358	533	80	411
450 mm (CL600), derated						743	596	358	358	533	80	638
450 mm (CL600)		823	823	823		743	596	358	358	508	80	625
450 mm (CL900)			988	987		787	596	358	358	505	80	852
450 mm EN 1092-1 PN10	682	677	679	680		615	596	358	358	532	80	173
450 mm EN 1092-1 PN16	682	677	679	680		640	596	358	358	550	80	197
450 mm EN 1092-1 PN25	761	756	758	759		670	596	358	358	555	80	338
450 mm EN 1092-1 PN40	761	756	758	759		685	596	358	358	560	80	371
450 mm AS2129 TABLE D	682	677	679	680		640	596	358	358	532	80	161
450 mm AS2129 TABLE E	682	677	679	680		640	596	358	358	552	80	188
450 mm JIS B2220 - 10K	682	677	679	680		620	596	358	358	530	80	169
450 mm JIS B2220 - 20K	761	756	758	759		675	596	358	358	560	80	340
450 mm AS4087 PN16	682	677	679	680		640	596	358	358	552	80	146
450 mm AS4087 PN21	682	677	679	680		675	596	358	358	571	80	205
450 mm AS4087 PN35	761	756	758	759		675	596	358	358	533	80	416
500 mm (CL150)	756	751	754	754		699	647	384	384	584	80	258
500 mm (CL300)	839	834	836	837		775	647	384	384	584	80	511
500 mm (CL600), derated	936					813	647	384	384	584	80	827
500 mm (CL600)		928	928	928		813	647	384	384	559	80	812

Table 24: MS sensors with 80 mm to 900 mm slip-on flanges dimensions in mm (continued)

Size, description	Overall length (Dim A)				ø B	ø C	Dim D		ø J	Dim K	Tube weight (kg)
	PTFE	Neoprene	Linatex	Poly			PFA/PFA+	Style A(1)			
500 mm (CL900)			1064	1063		647	384	384	556	80	1037
500 mm EN 1092-1 PN10	756	751	754	754		647	384	384	585	80	215
500 mm EN 1092-1 PN16	756	751	754	754		647	384	384	610	80	257
500 mm EN 1092-1 PN25	839	834	836	837		647	384	384	615	80	423
500 mm EN 1092-1 PN40	839	834	836	837		647	384	384	615	80	459
500 mm AS2129 TABLE D	756	751	754	754		647	384	384	609	80	214
500 mm AS2129 TABLE E	756	751	754	754		647	384	384	609	80	239
500 mm JIS B2220 - 10K	756	751	754	754		647	384	384	585	80	206
500 mm JIS B2220 - 20K	839	834	836	837		647	384	384	615	80	417
500 mm AS4087 PN16	756	751	754	754		647	384	384	609	80	205
500 mm AS4087 PN21	756	751	754	754		647	384	384	634	80	285
500 mm AS4087 PN35	839	834	836	837		647	384	384	597	80	487
600 mm (CL150)	908	903	905	906		763	442	441	692	80	375
600 mm (CL300)	1000	995	997	998		763	442	441	692	80	784
600 mm (CL600), derated	1050					763	442	441	692	80	1220
600 mm (CL900)		1042	1042	1042		763	442	441	660	80	1201
600 mm EN 1092-1 PN10	908	903	905	906		763	442	441	685	80	300
600 mm EN 1092-1 PN16	908	903	905	906		763	442	441	725	80	377
600 mm EN 1092-1 PN25	1000	995	997	998		763	442	441	720	80	613
600 mm EN 1092-1 PN40	1000	995	997	998		763	442	441	735	80	738
600 mm AS2129 TABLE D	908	903	905	906		763	442	441	720	80	314
600 mm AS2129 TABLE E	908	903	905	906		763	442	441	717	80	370
600 mm JIS B2220 - 10K	908	903	905	906		763	442	441	690	80	299
600 mm JIS B2220 - 20K	1000	995	997	998		763	442	441	720	80	614
600 mm AS4087 PN16	908	903	905	906		763	442	441	720	80	322

Table 24: MS sensors with 80 mm to 900 mm slip-on flanges dimensions in mm (continued)

Size, description	Overall length (Dim A)					ø B	ø C	Dim D		ø J	Dim K	Tube weight (kg)
	PTFE	Neoprene	Linatex	Poly	PFA/PFA+			Style A ⁽¹⁾	Style B ⁽²⁾			
600 mm AS4087 PN21	1000	995	997	998		850	763	442	441	739	80	587
600 mm AS4087 PN35	1000	995	997	998		850	763	442	441	699	80	693
750 mm MSS SP44 - 150#	1056	1050	1053	1053		984	902	511	511	857	80	708
750 mm MSS SP44 - 300#	1200	1195	1197	1198		1092	902	511	511	857	80	1338
750 mm AS2129 TABLE D	940	935	937	941		995	902	511	511	888	80	470
750 mm AS2129 TABLE E	1056	1050	1053	1053		995	902	511	511	857	80	578
750 mm AS4087 PN16	940	935	937	938		995	902	511	511	888	80	492
750 mm AS4087 PN21	1056	1050	1053	1053		1015	902	511	511	76	80	486
750 mm AS4087 PN35	1200	1195	1197	1198		1015	902	511	511	898	80	1112
900 mm MSS SP44 - 150#	1200	1195	1197	1198		1168	1102	610	611	1022	80	1157
900 mm MSS SP44 - 300#	1351	1345	1348	1348		1270	1102	610	611	1022	86	2079
900 mm AS2129 TABLE D	1032	1027	1029	1033		1175	1102	610	611	1050	80	687
900 mm AS2129 TABLE E	1200	1195	1197	1198		1175	1102	610	611	1050	80	955
900 mm AS4087 PN16	1032	1027	1029	1030		1175	1102	610	611	1050	80	707
900 mm AS4087 PN21	1200	1195	1197	1198		1185	1102	610	611	1060	80	935
900 mm AS4087 PN35	1351	1345	1348	1348		1185	1102	610	611	1030	86	1679

(1) With approval code NH, but not dual seal (DS) models.

(2) With approval codes other than NH, and with dual seal (DS) models.

MS sensors with weld-neck flanges

Figure 9: MS sensors with 3 inch to 36 inch weld-neck flanges dimensional drawing

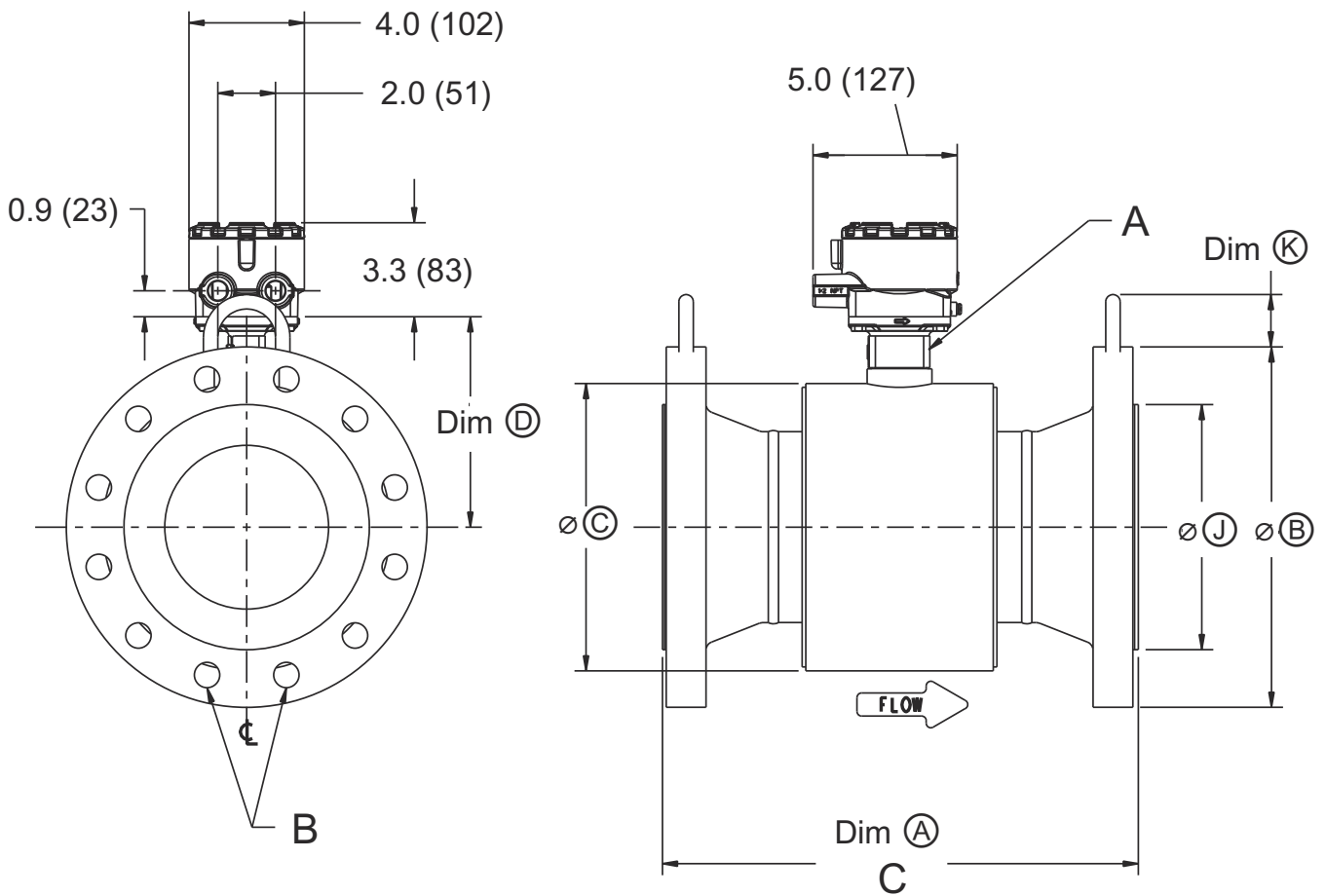

- A. Nameplate
- B. Flange bolts to straddle center line
- C. Dim A for flow meters with slip-on flat face flanges is equal to that of a raised face flange. If using lining protectors, see [Lining protectors](#). If using grounding protectors, see [Ground rings](#).

Style A shown. See [Housing style differentiation](#).

See [Table 25](#) for A, B, C, D, J, and K.

Table 25: MS sensors with 3 inch to 36 inch weld-neck flanges dimensions in inches

Size (ASME Class) ⁽¹⁾	Dim (A)				ø (B)	ø (C)	Dim (D)		ø (J)	ø (K)	Tube weight lb
	PTFE	Neoprene	Linatex	Poly			Style A	Style B			
3 inch (CL150)	12.17	12.06	12.12	12.18	7.50	7.21	5.82	5.97	5.00	1.70	43
3 inch (CL300)	12.17	12.06	12.12	12.18	8.25	7.21	5.82	5.97	5.00	1.70	53
3 inch (CL600), derated	13.03				8.25	7.21	5.82	5.97	4.63	1.70	59
3 inch (CL600)		12.78	12.78	12.78	8.25	7.21	5.82	5.97	4.63	1.70	57
3 inch (CL900)		14.38	14.38	14.38	9.50	7.21	5.82	5.97	4.63	1.70	83
3 inch (CL1500)		16.27	16.27	16.27	10.50	7.21	5.82	5.97	4.33	1.70	123
3 inch (CL2500)		20.42	20.42	20.42	12.00	7.21	5.82	5.97	4.15	1.70	209
3 inch (CL600) RTJ		12.94	12.94	12.94	8.25	7.21	5.82	5.97	4.00	1.70	59
3 inch (CL900) RTJ		14.54	14.54	14.54	9.50	7.21	5.82	5.97	3.94	1.70	85
3 inch (CL1500) RTJ		16.42	16.42	16.42	10.50	7.21	5.82	5.97	3.97	1.70	126
3 inch (CL2500) RTJ		20.70	20.70	20.70	12.00	7.21	5.82	5.97	3.41	1.70	213
4 inch (CL150)	13.94	13.81	13.87	13.96	9.00	7.91	6.17	6.32	6.19	1.70	60
4 inch (CL300)	13.94	13.81	13.87	13.96	10.00	7.91	6.17	6.32	6.19	1.70	81
4 inch (CL600), derated	15.84				10.75	7.91	6.17	6.32	5.81	1.70	109
4 inch (CL600)		15.57	15.57	15.57	10.75	7.91	6.17	6.32	5.81	1.70	106
4 inch (CL900)		16.81	16.81	16.81	11.50	7.91	6.17	6.32	5.81	2.00	137
4 inch (CL1500)		18.18	18.18	18.18	12.25	7.91	6.17	6.32	5.71	2.00	185
4 inch (CL2500)		23.71	23.71	23.71	14.00	7.91	6.17	6.32	5.54	2.00	328
4 inch (CL600) RTJ		15.73	15.73	15.73	10.75	7.91	6.17	6.32	4.94	1.70	107
4 inch (CL900) RTJ		16.97	16.97	16.97	11.50	7.91	6.17	6.32	4.94	2.00	140
4 inch (CL1500) RTJ		18.33	18.33	18.33	12.25	7.91	6.17	6.32	5.54	2.00	188
4 inch (CL2500) RTJ		24.12	24.12	24.12	14.00	7.91	6.17	6.32	4.38	2.00	336
6 inch (CL150)	16.66	16.48	16.54	16.60	11.00	9.98	7.30	7.35	8.50	1.70	100
6 inch (CL300)	16.66	16.48	16.54	16.60	12.50	9.98	7.30	7.35	8.50	1.70	142
6 inch (CL600), derated	19.05				14.00	9.98	7.30	7.35	8.00	1.70	231
6 inch (CL600)		18.73	18.73	18.73	14.00	9.98	7.30	7.35	8.00	1.70	225

Table 25: MS sensors with 3 inch to 36 inch weld-neck flanges dimensions in inches (continued)

Size (ASME Class) ⁽¹⁾	Dim (A)				ø (B)	ø (C)	Dim (D)		ø (J)	ø (K)	Tube weight lb
	PTFE	Neoprene	Linatex	Poly			Style A	Style B			
6 inch (CL900)		20.58	20.58	20.58	15.00	9.98	7.30	7.35	8.00	2.00	291
6 inch (CL1500)		23.84	23.84	23.84	15.50	9.98	7.30	7.35	7.70	2.00	423
6 inch (CL2500)		31.79	31.79	31.79	19.00	9.98	7.30	7.35	7.30	2.00	842
6 inch (CL600) RTJ		18.89	18.89	18.89	14.00	9.98	7.30	7.35	7.12	1.70	229
6 inch (CL900) RTJ		20.74	20.74	20.74	15.00	9.98	7.30	7.35	7.12	2.00	295
6 inch (CL1500) RTJ		24.12	24.12	24.12	15.50	9.98	7.30	7.35	6.73	2.00	430
6 inch (CL2500) RTJ		32.32	32.32	32.32	19.00	9.98	7.30	7.35	6.66	2.00	859
8 inch (CL150)	19.22	19.03	19.09	19.15	13.50	11.92	8.27	8.32	10.62	1.70	160
8 inch (CL300)	19.22	19.03	19.09	19.15	15.00	11.92	8.27	8.32	10.62	1.70	220
8 inch (CL600), derated	22.15				16.50	11.92	8.27	8.32	10.00	1.70	362
8 inch (CL600)		21.59	21.59	21.59	16.50	11.92	8.27	8.32	10.00	1.70	348
8 inch (CL900)		24.09	24.09	24.09	18.50	11.92	8.27	8.32	10.00	3.13	514
8 inch (CL1500)		28.70	28.70	28.70	19.00	11.92	8.27	8.32	9.76	3.13	747
8 inch (CL2500)		36.88	36.88	36.88	21.75	11.92	8.27	8.32	9.20	3.13	1344
8 inch (CL600) RTJ		21.75	21.75	21.75	16.50	11.92	8.27	8.32	9.37	1.70	353
8 inch (CL900) RTJ		24.25	24.25	24.25	18.50	11.92	8.27	8.32	9.13	3.13	520
8 inch (CL1500) RTJ		29.11	29.11	29.11	19.00	11.92	8.27	8.32	8.66	3.13	761
8 inch (CL2500) RTJ		37.53	37.53	37.53	21.75	11.92	8.27	8.32	8.28	3.13	1371
10 inch (CL150)	19.95	19.68	19.74	19.80	16.00	14.64	9.69	9.68	12.75	2.00	230
10 inch (CL300)	19.95	19.68	19.74	19.80	17.50	14.64	9.69	9.68	12.75	2.00	320
10 inch (CL600), derated	23.68				20.00	14.64	9.69	9.68	12.00	2.00	583
10 inch (CL600)		23.34	23.34	23.34	20.00	14.64	9.69	9.68	12.00	2.00	571
10 inch (CL900)		26.12	26.12	26.12	21.50	14.64	9.69	9.68	12.00	3.13	788
10 inch (CL1500)		32.03	32.03	32.03	23.00	14.64	9.69	9.68	11.50	3.13	1307
10 inch (CL600) RTJ		23.50	23.50	23.50	20.00	14.64	9.69	9.68	11.50	2.00	578
10 inch (CL900) RTJ		26.28	26.28	26.28	21.50	14.64	9.69	9.68	11.25	3.13	796

Table 25: MS sensors with 3 inch to 36 inch weld-neck flanges dimensions in inches (continued)

Size (ASME Class) ⁽¹⁾	Dim (A)				ø (B)	ø (C)	Dim (D)		ø (J)	ø (K)	Tube weight lb
	PTFE	Neoprene	Linatex	Poly			Style A	Style B			
10 inch (CL1500) RTJ		32.44	32.44	32.44	23.00	14.64	9.69	9.68	10.78	3.13	1325
12 inch (CL150)	28.83	23.49	23.55	23.61	19.00	16.50	10.77	10.61	15.00	2.00	349
12 inch (CL300)	23.83	23.49	23.55	23.61	20.50	16.50	10.77	10.61	15.00	2.00	464
12 inch (CL600), derated	26.93				22.00	16.50	10.77	10.61	14.00	2.00	758
12 inch (CL600)		26.59	26.59	26.59	22.00	16.50	10.77	10.61	14.00	2.00	746
12 inch (CL900)		30.33	30.33	30.33	24.00	16.50	10.77	10.61	14.00	3.13	1097
12 inch (CL1500)		37.11	37.11	37.11	26.50	16.50	10.77	10.61	13.18	3.13	2016
12 inch (CL600) RTJ		26.75	26.75	26.75	22.00	16.50	10.77	10.61	13.75	2.00	754
12 inch (CL900) RTJ		30.49	30.49	30.49	24.00	16.50	10.77	10.61	13.50	3.13	1107
12 inch (CL1500) RTJ		37.76	37.76	37.76	26.50	16.50	10.77	10.61	12.28	3.13	2052
14 inch (CL150)	27.20	27.00	27.06	27.12	21.00	18.92	11.83	11.82	16.25	2.00	452
14 inch (CL300)	27.20	27.00	27.06	27.12	23.00	18.92	11.83	11.82	16.25	2.00	661
14 inch (CL600), derated	30.29				23.75	18.92	11.83	11.82	15.25	2.00	938
14 inch (CL600)		29.95	29.95	29.95	23.75	18.92	11.83	11.82	15.25	2.00	924
14 inch (CL900)		34.47	34.31	34.47	25.25	18.92	11.83	11.82	15.13	2.00	1373
14 inch (CL900) RTJ		34.78	34.82	34.78	25.25	18.92	11.83	11.82	15.44	2.00	1373
14 inch (CL600) RTJ		30.11	30.11	30.11	23.75	18.92	11.83	11.82	15.00	2.00	936
16 inch (CL150)	29.78	29.58	29.64	29.70	23.50	20.94	12.84	12.83	18.50	3.13	487
16 inch (CL300)	29.78	29.58	29.64	29.70	25.50	20.94	12.84	12.83	17.50	3.13	853
16 inch (CL600), derated	33.57				27.00	20.94	12.84	12.83	17.50	3.13	1274
16 inch (CL600)		33.23	33.23	33.23	27.00	20.94	12.84	12.83	17.50	3.13	1256
16 inch (CL600) RTJ		33.39	33.39	33.39	27.00	20.94	12.84	12.83	17.00	3.13	1268
16 inch (CL900)		37.01	37.05	37.05	27.75	20.94	12.84	12.83	17.38	3.13	1683
16 inch (CL900) RTJ		37.42	37.46	37.42	27.75	20.94	12.84	12.83	17.32	3.13	1683
18 inch (CL150)	31.97	31.77	31.83	31.89	25.00	23.46	14.10	14.09	21.00	3.13	679
18 inch (CL300)	31.97	31.77	31.83	31.89	28.00	23.46	14.10	14.09	21.00	3.13	1094

Table 25: MS sensors with 3 inch to 36 inch weld-neck flanges dimensions in inches (continued)

Size (ASME Class) ⁽¹⁾	Dim (A)				ø (B)	ø (C)	Dim (D)		ø (J)	ø (K)	Tube weight lb
	PTFE	Neoprene	Linatex	Poly			Style A	Style B			
18 inch (CL600), derated	35.23				29.25	23.46	14.10	14.09	20.00	3.13	1531
18 inch (CL600)		34.89	34.89	34.89	29.25	23.46	14.10	14.09	20.00	3.13	1508
18 inch (CL900)		39.01	39.05	39.01	31.00	23.46	14.10	14.09	19.88	3.13	2167
18 inch (CL900) RTJ		39.54	39.58	39.54	31.00	23.46	14.10	14.09	19.69	3.13	2167
18 inch (CL600) RTJ		35.05	35.05	35.05	29.25	23.46	14.10	14.09	19.38	3.13	1523
20 inch (CL150)	34.76	34.56	34.62	34.68	27.50	25.48	15.11	15.10	23.00	3.13	722
20 inch (CL300)	34.76	34.56	34.62	34.68	30.50	25.48	15.11	15.10	23.00	3.13	1337
20 inch (CL600), derated	38.26				32.00	25.48	15.11	15.10	22.00	3.13	1892
20 inch (CL600)		37.93	37.93	37.93	32.00	25.48	15.11	15.10	22.00	3.13	1865
20 inch (CL900)		43.01	43.05	43.01	33.75	25.48	15.11	15.10	21.88	3.13	2681
20 inch (CL900) RTJ		43.54	43.58	43.54	33.75	25.48	15.11	15.10	21.63	3.13	2681
20 inch (CL600) RTJ		38.21	38.21	38.21	32.00	25.48	15.11	15.10	21.00	3.13	1893
24 inch (CL150)	38.30	38.10	38.16	38.22	32.00	30.03	17.39	17.38	27.25	3.13	1118
24 inch (CL300)	38.30	38.10	38.16	38.22	36.00	30.03	17.39	17.38	27.25	3.13	1964
24 inch (CL600), derated	42.33				37.00	30.03	17.39	17.38	26.00	3.13	2838
24 inch (CL600)		41.99	41.99	41.99	37.00	30.03	17.39	17.38	26.00	3.13	2806
24 inch (CL600) RTJ		42.40	42.40	42.40	37.00	30.03	17.39	17.38	25.00	3.13	2854
30 inch ASME B16.47 Series A (CL150)	41.56	41.36	41.45	41.48	38.75	35.50	20.13	20.11	33.75	3.13	1679
30 inch ASME B16.47 Series A (CL300)	47.16	46.96	47.02	47.08	43.00	35.50	20.13	20.11	33.75	3.13	3166
36 inch ASME B16.47 Series A (CL150)	47.25	47.05	47.14	47.17	46.00	43.37	24.00	24.05	40.25	3.13	2728
36 inch ASME B16.47 Series A (CL300)	53.16	52.96	53.02	53.08	50.00	43.37	24.00	24.05	40.25	3.38	4723

(1) Standard raised face flanges unless marked "RTJ" (Ring Type Joint).

Table 26: MS sensors with 80 mm to 900 mm weld-neck flanges dimensions in mm

Size (ASME Class) ⁽¹⁾	Dim (A)			ø (B)	ø (C)	Dim (D)		ø (J)	ø (K)	Tube weight lb
	PTFE	Neoprene	Linatex			Poly	Style A			
80 mm (CL150)	309	306	308	309	191	183	148	127	43	20
80 mm (CL300)	309	306	308	309	210	183	148	127	43	24
80 mm (CL600), derated	331				210	183	148	117	43	27
80 mm (CL600)		325	325	325	210	183	148	117	43	26
80 mm (CL900)		365	365	365	241	183	148	117	43	38
80 mm (CL1500)		413	413	413	267	183	148	110	43	56
80 mm (CL2500)		519	519	519	305	183	148	105	43	95
80 mm (CL600) RTJ		329	329	329	210	183	148	102	43	27
80 mm (CL900) RTJ		369	369	369	241	183	148	100	43	39
80 mm (CL1500) RTJ		417	417	417	267	183	148	101	43	57
80 mm (CL2500) RTJ		526	526	526	305	183	148	87	43	97
100 mm (CL150)	354	351	352	355	229	201	157	157	43	27
100 mm (CL300)	354	351	352	355	254	201	157	157	43	37
100 mm (CL600), derated	402				273	201	157	148	43	49
100 mm (CL600)		396	396	396	273	201	157	148	43	48
100 mm (CL900)		427	427	427	292	201	157	148	51	62
100 mm (CL1500)		462	462	462	311	201	157	145	51	84
100 mm (CL2500)		602	602	602	356	201	157	141	51	149
100 mm (CL600) RTJ		400	400	400	273	201	157	125	43	49
100 mm (CL900) RTJ		431	431	431	292	201	157	125	51	63
100 mm (CL1500) RTJ		466	466	466	311	201	157	141	51	85
100 mm (CL2500) RTJ		613	613	613	356	201	157	111	51	152
150 mm (CL150)	423	419	420	422	279	253	185	216	43	45
150 mm (CL300)	423	419	420	422	318	253	185	203	43	64
150 mm (CL600), derated	484				356	253	185	203	43	105
150 mm (CL600)		476	476	476	356	253	185	203	43	102

Table 26: MS sensors with 80 mm to 900 mm weld-neck flanges dimensions in mm (continued)

Size (ASME Class) ⁽¹⁾	Dim (A)				ø (B)	ø (C)	Dim (D)		ø (J)	ø (K)	Tube weight lb
	PTFE	Neoprene	Linatex	Poly			Style A	Style B			
150 mm (CL900)		523	523	523	381	253	185	187	203	51	132
150 mm (CL1500)		605	605	605	394	253	185	187	196	51	192
150 mm (CL2500)		807	807	807	483	253	185	187	185	51	382
150 mm (CL600) RTJ		480	480	480	356	253	185	187	181	43	104
150 mm (CL900) RTJ		527	527	527	381	253	185	187	181	51	134
150 mm (CL1500) RTJ		613	613	613	394	253	185	187	171	51	195
150 mm (CL2500) RTJ		821	821	821	483	253	185	187	169	51	390
200 mm (CL150)	488	483	485	486	343	303	210	211	270	43	73
200 mm (CL300)	488	483	485	486	381	303	210	211	254	43	100
200 mm (CL600), derated	563				419	303	210	211	254	43	164
200 mm (CL600)		548	548	548	419	303	210	211	254	43	158
200 mm (CL900)		612	612	612	470	303	210	211	254	80	233
200 mm (CL1500)		729	729	729	483	303	210	211	248	80	339
200 mm (CL2500)		937	937	937	552	303	210	211	234	80	609
200 mm (CL600) RTJ		552	552	552	419	303	210	211	238	43	160
200 mm (CL900) RTJ		616	616	616	470	303	210	211	232	80	236
200 mm (CL1500) RTJ		739	739	739	483	303	210	211	220	80	345
200 mm (CL2500) RTJ		953	953	953	552	303	210	211	210	80	622
250 mm (CL150)	507	500	501	503	406	372	246	246	324	51	104
250 mm (CL300)	507	500	501	503	445	372	246	246	324	51	145
250 mm (CL600), derated	601				508	372	246	246	305	51	265
250 mm (CL600)		593	593	593	508	372	246	246	305	51	259
250 mm (CL900)		663	663	663	546	372	246	246	305	80	357
250 mm (CL1500)		813	813	813	584	372	246	246	292	80	593
250 mm (CL600) RTJ		597	597	597	508	372	246	246	292	51	262
250 mm (CL900) RTJ		668	668	668	546	372	246	246	286	80	361

Table 26: MS sensors with 80 mm to 900 mm weld-neck flanges dimensions in mm (continued)

Size (ASME Class) ⁽¹⁾	Dim (A)				ø (B)	ø (C)	Dim (D)		ø (J)	ø (K)	Tube weight lb
	PTFE	Neoprene	Linatex	Poly			Style A	Style B			
250 mm (CL1500) RTJ		824	824	824	584	372	246	246	274	80	601
300 mm (CL150)	605	597	598	600	483	419	274	269	381	51	158
300 mm (CL300)	605	597	598	600	521	419	274	269	381	51	211
300 mm (CL600), derated	684				559	419	274	269	356	51	344
300 mm (CL600)		675	675	675	559	419	274	269	356	51	338
300 mm (CL900)		770	770	770	610	419	274	269	356	80	498
300 mm (CL1500)		942	942	942	673	419	274	269	335	80	915
300 mm (CL600) RTJ		679	679	679	559	419	274	269	349	51	342
300 mm (CL900) RTJ		774	774	774	610	419	274	269	343	80	502
300 mm (CL1500) RTJ		959	959	959	673	419	274	269	312	80	931
350 mm (CL150)	691	686	687	689	533	481	300	300	413	51	205
350 mm (CL300)	691	686	687	689	584	481	300	300	413	51	300
350 mm (CL600), derated	769				603	481	300	300	413	51	426
350 mm (CL600)		761	761	761	603	481	300	300	387	51	419
350 mm (CL900)		874	873	873	641	481	300	300	384	51	623
350 mm (CL900) RTJ		883	884	883	641	481	300	300	392	51	623
350 mm (CL600) RTJ		765	765	765	603	481	300	300	381	51	424
400 mm (CL150)	757	751	753	754	597	532	326	326	470	80	221
400 mm (CL300)	757	751	753	754	648	532	326	326	470	80	387
400 mm (CL600), derated	853				686	532	326	326	445	80	578
400 mm (CL600)		844	844	844	686	532	326	326	445	80	570
400 mm (CL600) RTJ		848	848	848	686	532	326	326	432	80	575
400 mm (CL900)		940	941	940	705	532	326	326	441	80	763
400 mm (CL900) RTJ		950	951	950	705	532	326	326	440	80	763
450 mm (CL150)	812	807	808	810	635	596	358	358	533	80	308
450 mm (CL300)	812	807	808	810	711	596	358	358	533	80	496

Table 26: MS sensors with 80 mm to 900 mm weld-neck flanges dimensions in mm (continued)

Size (ASME Class) ⁽¹⁾	Dim (A)				ø (B)	ø (C)	Dim (D)		ø (J)	ø (K)	Tube weight lb
	PTFE	Neoprene	Linatex	Poly			Style A	Style B			
450 mm (CL600), derated	895				743	596	358	358	508	80	694
450 mm (CL600)		886	886	886	743	596	358	358	508	80	684
450 mm (CL900)		991	992	991	787	596	358	358	505	80	983
450 mm (CL900) RTJ		1004	1005	1004	787	596	358	358	500	80	983
450 mm (CL600) RTJ		890	890	890	743	596	358	358	492	80	691
500 mm (CL150)	883	878	879	881	699	647	384	384	584	80	327
500 mm (CL300)	883	878	879	881	775	647	384	384	584	80	606
500 mm (CL600), derated	972				813	647	384	384	559	80	858
500 mm (CL600)		963	963	963	813	647	384	384	559	80	846
500 mm (CL900)		1092	1093	1092	857	647	384	384	556	80	1216
500 mm (CL900) RTJ		1106	1107	1106	857	647	384	384	549	80	1216
500 mm (CL600) RTJ		971	971	971	813	647	384	384	533	80	858
600 mm (CL150)	973	968	969	971	813	763	442	441	692	80	507
600 mm (CL300)	973	968	969	971	914	763	442	441	692	80	891
600 mm (CL600), derated	1075				940	763	442	441	660	80	1287
600 mm (CL600)		1067	1067	1067	940	763	442	441	660	80	1273
600 mm (CL600) RTJ		1077	1077	1077	940	763	442	441	635	80	1295
750 mm ASME B16.47 Series A (CL150)	1056	1050	1053	1053	984	902	511	511	857	80	761
750 mm ASME B16.47 Series A (CL300)	1198	1193	1194	1196	1092	902	511	511	857	80	1436
900 mm ASME B16.47 Series A (CL150)	1200	1195	1197	1198	1168	1102	610	611	1022	80	1237
900 mm ASME B16.47 Series A (CL300)	1350	1345	1347	1348	1270	1102	610	611	1022	86	2143

(1) Standard raised face flanges unless marked "RTJ" (Ring Type Joint).

Figure 10: MS sensors with 3 inch to 36 inch weld-neck flanges with M2 option body width

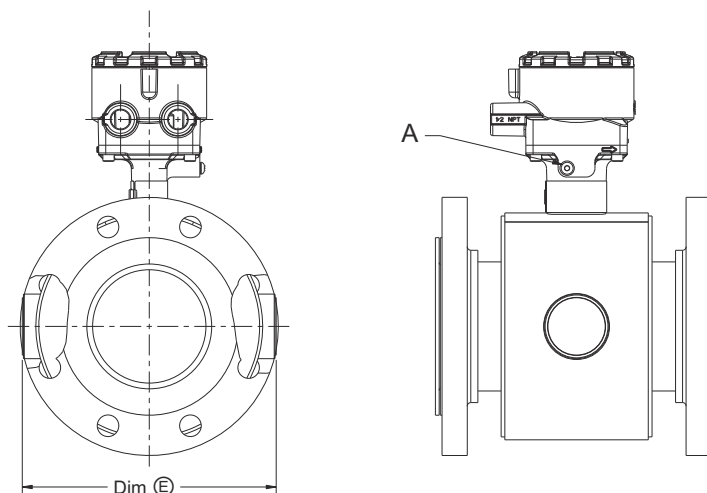

A. See [Figure 7](#).

B. Dim E for flow meters with slip-on flat face flanges is equal to that of a raised face flange. If using lining protectors, see [Lining protectors](#). If using grounding protectors, see [Ground rings](#).

Table 27: Body width with M2 and M4 options

Size in inches (mm)	Body width E with M2 option (Figure 10) in inches (mm)	Body width E with M4 option (Figure 11) in inches (mm)
3 (80)	7.9 (200)	8.2 (208)
4 (100)	8.9 (226)	9.2 (234)
6 (150)	10.6 (270)	10.9 (278)
8 (200)	12.6 (321)	12.9 (329)
10 (250)	15.5 (394)	15.9 (403)
12 (300)	17.5 (445)	17.9 (453)
14 (350)	20.7 (525)	21.0 (533)
16 (400)	22.7 (576)	23.0 (584)
18 (450)	24.7 (627)	25.0 (635)
20 (500)	26.7 (678)	27.0 (686)
24 (600)	30.7 (779)	31.0 (787)
30 (750)	36.7 (932)	37.0 (940)
36 (900)	44.2 (1122)	44.5 (1130)

Figure 11: MS sensors with 3 inch to 36 inch weld-neck flanges with M4 option body width

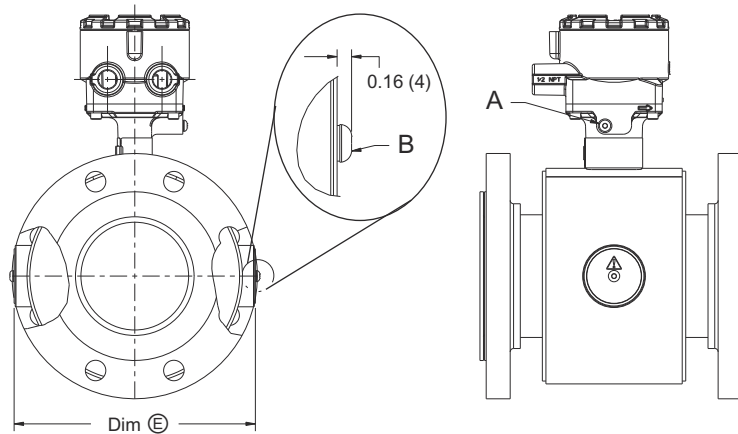

MS Sensors with grooved coupling

Figure 12: MS Sensors with grooved coupling dimensional drawing

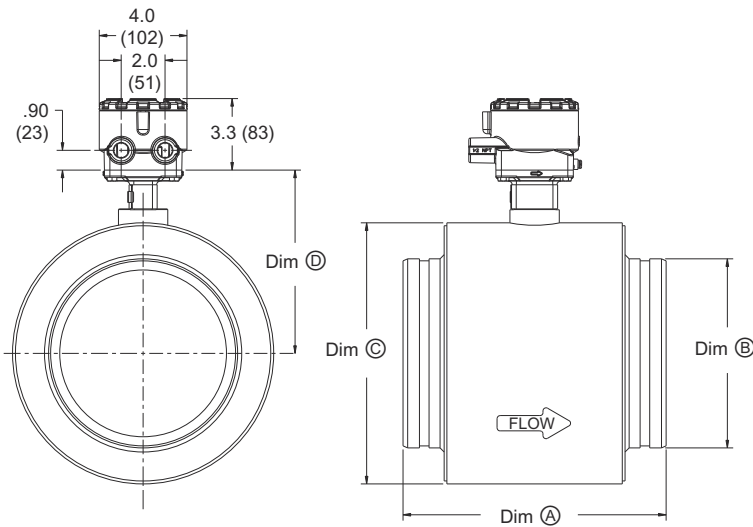

Style A shown. See [Housing style differentiation](#).

See [Table 28](#) for A, B, C, and D.

Table 28: MS Sensors with grooved coupling dimensions in inches (mm)

Line size	Dimensions from Figure 12				
	Dim A	Dim B	Dim C	Dim D	
				Style A	Style B
3 (80)	12.5 (318)	3.5 (90)	7.2 (183)	5.8 (148)	6.0 (152)
4 (100)	12.0 (305)	4.5 (114)	7.9 (201)	6.2 (157)	6.3 (160)
6 (150)	12.0 (305)	6.6 (168)	10.0 (253)	7.4 (188)	7.4 (187)
8 (200)	12.0 (305)	8.6 (219)	11.9 (303)	8.4 (212)	8.3 (211)
10 (250)	16.0 (406)	10.8 (273)	14.6 (372)	9.7 (246)	9.7 (246)

Lining protectors

Figure 13: Lining protectors

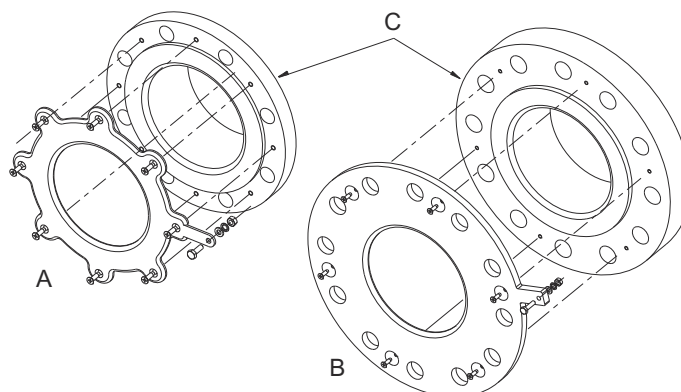

- A. Stamped
- B. Machined
- C. Sensor

Table 29: Lining protector thickness

Line size	Thickness (qty 1) in inches (mm). Add value to Dim Ⓐ from applicable sensor dimensional drawings		Thickness (qty 2) in inches (mm). Add value to Dim Ⓐ from applicable sensor dimensional drawings	
	Min	Max	Min	Max
3 (80)	0.105 (2.7)	0.190 (4.8)	0.210 (5.3)	0.380 (9.7)
4 (100)	0.105 (2.7)	0.190 (4.8)	0.210 (5.3)	0.380 (9.7)
6 (150)	0.100 (2.5)	0.190 (4.8)	0.200 (5.1)	0.380 (9.7)
8 (200)	0.090 (2.3)	0.190 (4.8)	0.180 (4.6)	0.380 (9.7)
10 (250)	0.110 (2.8)	0.185 (4.7)	0.220 (5.6)	0.370 (9.4)
12 (300)	0.110 (2.8)	0.185 (4.7)	0.220 (5.6)	0.370 (9.4)
14 (350)	0.150 (3.8)	0.185 (4.7)	0.300 (7.6)	0.370 (9.4)
16 (400)	0.150 (3.8)	0.185 (4.7)	0.300 (7.6)	0.370 (9.4)
18 (450)	0.150 (3.8)	0.162 (4.1)	0.300 (7.6)	0.324 (8.2)
20 (500)	0.150 (3.8)	0.162 (4.1)	0.300 (7.6)	0.324 (8.2)
24 (600)	0.150 (3.8)	0.162 (4.1)	0.300 (7.6)	0.324 (8.2)
30 (750)	0.285 (7.2)	0.285 (7.2)	0.570 (14.5)	0.570 (14.5)
36 (900)	0.410 (10.4)	0.410 (10.4)	0.820 (20.8)	0.820 (20.8)

Note

The precise value is also dependent upon the flange rating and material of construction. For precise dimensions, consult an Emerson Flow representative (see back page).

Ground rings

Figure 14: Ground rings

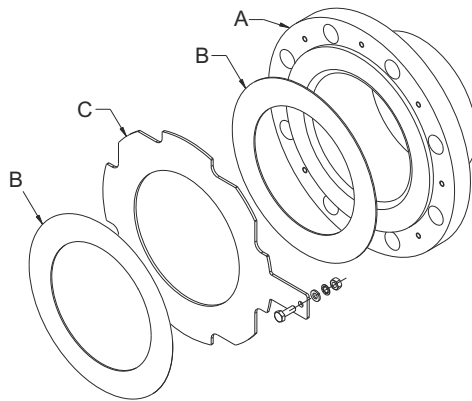

- A. Sensor
- B. Customer-supplied gaskets
- C. Ground ring

Table 30: Ground ring thickness

Line size	Thickness (qty 1) in inches (mm). Add value to Dim [Ⓐ] from applicable sensor dimensional drawings		Thickness (qty 2) in inches (mm). Add value to Dim [Ⓐ] from applicable sensor dimensional drawings	
	Min	Max	Min	Max
3 (80)	0.045 (1.1)	0.120 (3.0)	0.090 (2.3)	0.240 (6.1)
4 (100)	0.045 (1.1)	0.120 (3.0)	0.090 (2.3)	0.240 (6.1)
6 (150)	0.045 (1.1)	0.120 (3.0)	0.090 (2.3)	0.240 (6.1)
8 (200)	0.045 (1.1)	0.120 (3.0)	0.090 (2.3)	0.240 (6.1)
10 (250)	0.045 (1.1)	0.120 (3.0)	0.090 (2.3)	0.240 (6.1)
12 (300)	0.045 (1.1)	0.120 (3.0)	0.090 (2.3)	0.240 (6.1)
14 (350)	0.045 (1.1)	0.250 (6.4)	0.090 (2.3)	0.500 (12.7)
16 (400)	0.045 (1.1)	0.250 (6.4)	0.090 (2.3)	0.500 (12.7)
18 (450)	0.120 (3.0)	0.250 (6.4)	0.240 (6.1)	0.500 (12.7)
20 (500)	0.120 (3.0)	0.250 (6.4)	0.240 (6.1)	0.500 (12.7)
24 (600)	0.187 (4.7)	0.250 (6.4)	0.374 (9.5)	0.500 (12.7)
30 (750)	0.187 (4.7)	0.250 (6.4)	0.374 (9.5)	0.500 (12.7)
36 (900)	0.187 (4.7)	0.250 (6.4)	0.374 (9.5)	0.500 (12.7)

Note

The precise value does not include customer-supplied gaskets and is also dependent upon the flange rating and material of construction. For precise dimensions, consult an Emerson Flow representative (see back page).

Rosemount 8785 Calibration Standard dimensions

Figure 15: Rosemount 8785 Calibration Standard dimensions

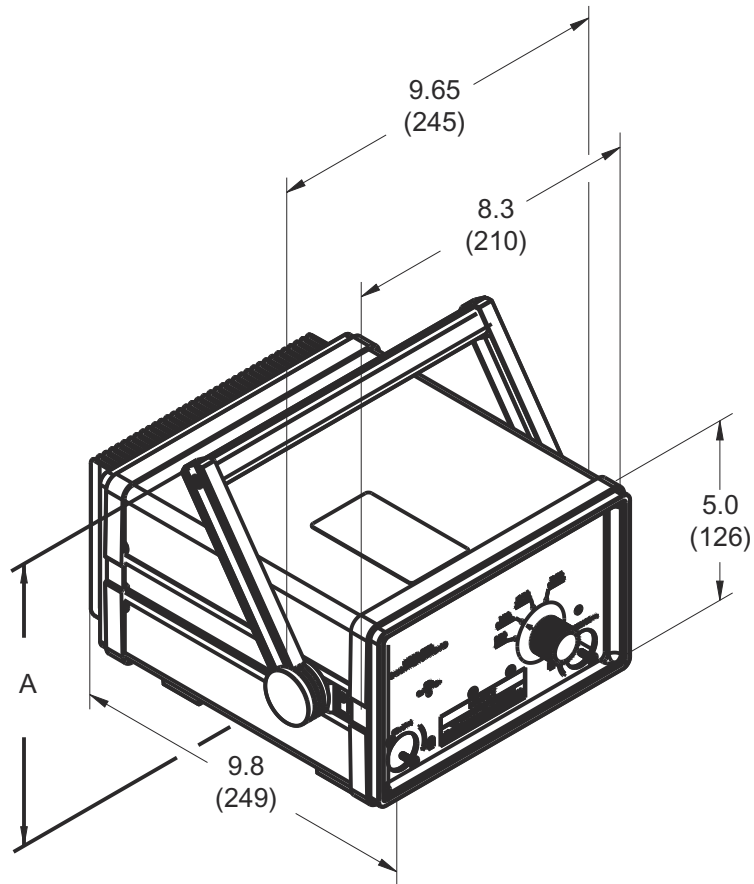

A. Maximum 7.87 inch (200 mm)

Emerson Automation Solutions

United States:
T: +1 800-522-6277
T: +1 303-527-5200
F: +1 303-530-8459
Mexico: +52 55 5809 5473
Argentina: +54 11 4733 5400
Brazil: +55 15 3413 8888
Chile: +56 22 4310 7432

Emerson Automation Solutions

Central Europe: +41 41 7686 111
Eastern Europe: +41 41 7686 111
Dubai: +971 4 811 8100
Abu Dhabi: +971 2 697 2000
France: +33 0800 917 901
Germany: +49 (0) 2173 3348 0
Italy: +39 8008 77334
The Netherlands: +31 (0) 70 413 6666
Belgium: +32 2 716 77 11
Spain: +34 913 586 000
U.K.: +44 0870 240 1978
Russia/CIS: +7 495 995 9559

Emerson Automation Solutions

Australia: +61 3 9721 0200
China: +86 21 2892 9000
India: +91 22 6662 0566
Japan: +81 3 5769 6803
South Korea: +82 31 8034 0000
Singapore: +65 6 363 7766

©2019 Rosemount, Inc. All rights reserved.

The Emerson and Rosemount logos are trademarks and service marks of Emerson Electric Co. All other marks are property of their respective owners.