

MPX Magnetostrictive Level Sensors User Manual

For The MPX-F

Table of Contents

Introduction	iii
Warranty and Warranty Restrictions	iv
Chapter 1: Specifications and Options.....	1
Dimensions	1-2
Specifications	3
Model Number Configurator.....	4
Electrical Connections and System Wiring Diagrams	5-6
Chapter 2: Installation and Removal Procedures and Notes.....	7
Tools Needed.....	7
Physical Installation Notes	7
Physical Installation Instructions	8
Electrical Installation	9
Removal Instructions	9
Chapter 3: Programming	10
Modbus Programming	10
Modbus Programming with RST-6001 and APG Modbus Software	10
4-20 mA Programming with RST-4100 and APG Modbus Software.....	11
Modbus Register Lists for MPX-F4	11-12
MPX-F4 Modbus Sensor Parameters.....	13-17
APG Modbus Register Lists for MPX-F2 and MPX-F3.....	17-18
MPX-F2 and MPX-F3 APG Modbus Sensor Parameters	19-23
MPX-F Modbus Application Type Parameters	24-28
Chapter 4: Maintenance	29
General Care	29
Repair and Returns.....	29
Chapter 5: Hazardous Location Installation and Certification.....	30
Hazardous Location and Non-Incendive Wiring Diagram.....	30
CSA Certificate of Compliance	31-34

Introduction

Thank you for purchasing an MPX series magnetostrictive level sensor from APG. We appreciate your business and your trust. Please take a few minutes to familiarize yourself with your MPX and this manual.

The MPX level sensors provide highly accurate and repeatable level readings in a wide variety of liquid level measurement applications. The MPX-F is certified for installation in hazardous areas in the US and Canada by CSA for Class I, Division 2 and Class I, Zone 2 environments. The MPX-F's flexible stainless steel stem allows for accurate measurements in environments that are not straight-forward.

Reading your label

Every APG instrument comes with a label that includes the instrument's model number, part number, and serial number. Please ensure that the part number on your label matches your order. The following electrical ratings and approvals are also listed on the label. Please refer to the CSA Certificate of Compliance at the back of this manual for further details.

Electrical ratings



Rated 12 - 24 VDC, 4-20 mA, or 80 mA
Class I, Division 2, Groups C, and D
Ex nA IIB
Class I, Zone 2; AEx nA IIB
Non-Incendive Wiring Requirements: $V_{max} = 28VDC$, $I_{max} = 200mA$, $C_i = 0nF$, $L_i = 0\mu H$

i **IMPORTANT:** MPX-F level sensor **MUST** be installed according to drawing 9003468 (Hazardous Installation and Non-Incendive Wiring Drawing) on page 30 to meet listed approvals. Faulty installation will invalidate all safety approvals and ratings.

DANGER: OPEN CIRCUIT BEFORE REMOVING COVER or KEEP COVER TIGHT WHILE CIRCUITS ARE ALIVE;
AVERTISSEMENT -- OUVRIR LE CIRCUIT AVANT D'ENLEVER LE COUVERCLE, or GARDER LE COUVERCLE BIEN FERME TANT QUE LES CIRCUITS SONT SOUS TENSION.

DANGER: WARNING -- EXPLOSION HAZARD -- SUBSTITUTION OF COMPONENTS MAY IMPAIR SUITABILITY FOR CLASS I, DIVISION 2;
AVERTISSEMENT -- RISQUE D'EXPLOSION -- LA SUBSTITUTION DE COMPOSANTS PEUT ENDRE CE MATERIEL INACCEPTABLE POUR LES EMPLACEMENTS DE CLASSE I, DIVISION 2.

DANGER: WARNING -- EXPLOSION HAZARD -- DO NOT DISCONNECT EQUIPMENT UNLESS POWER HAS BEEN SWITCHED OFF OR THE AREA IS KNOWN TO BE NON-HAZARDOUS;
AVERTISSEMENT -- RISQUE D'EXPLOSION -- AVANT DE DECONNECTER L'EQUIPEMENT, COUPER LE COURANT OU S'ASSURER QUE L'EMPLACEMENT EST DESIGNÉ NON DANGEREUX.

Warranty and Warranty Restrictions

This product is covered by APG's warranty to be free from defects in material and workmanship under normal use and service of the product for 24 months. For a full explanation of our Warranty, please visit <https://www.apgsensors.com/about-us/terms-conditions>. Contact Technical Support to receive a Return Material Authorization before shipping your product back.

Scan the QR code below to read the full explanation of our Warranty on your tablet or smartphone.



Chapter 1: Specifications and Options

- Dimensions

MPX-F Sensor Dimensions

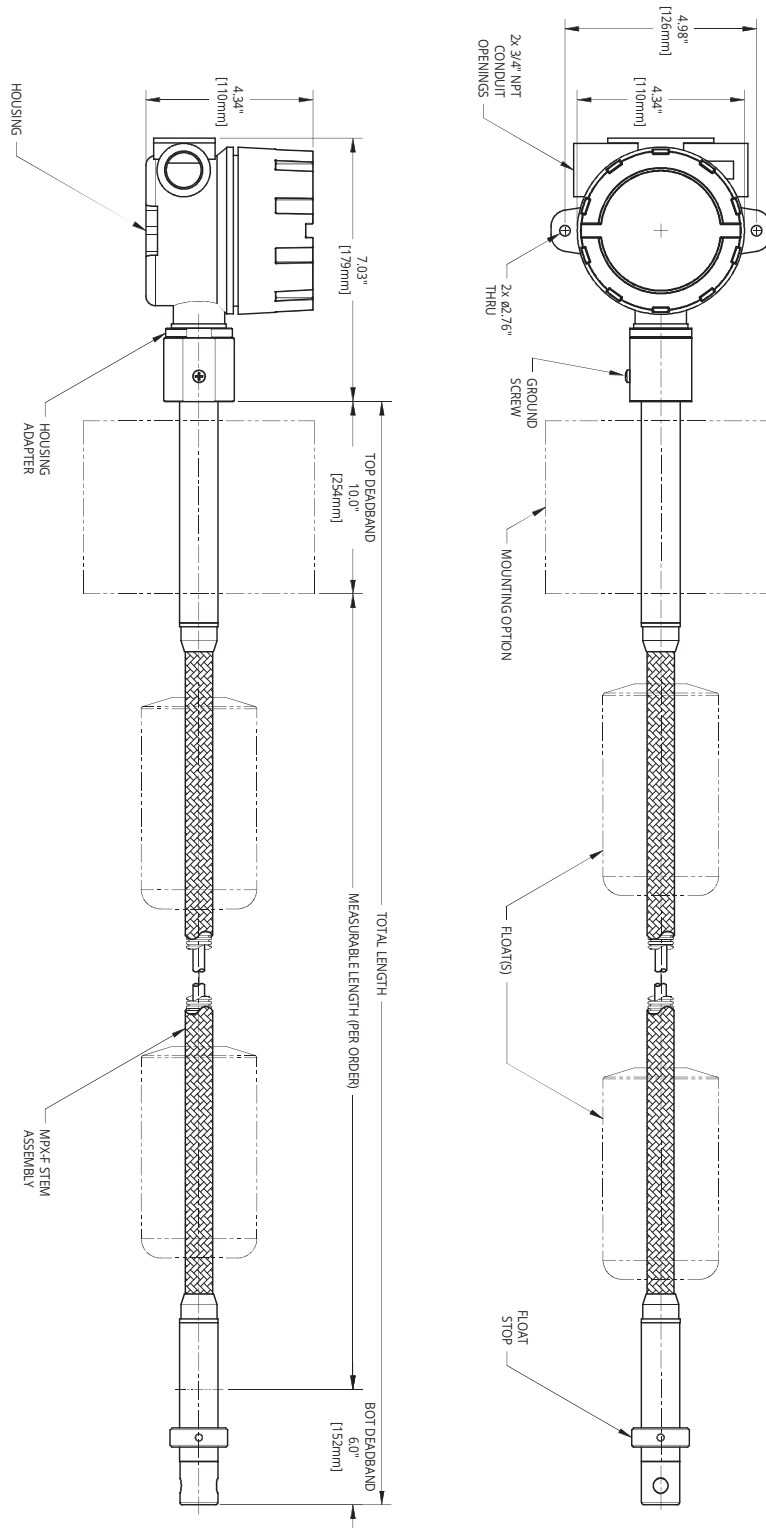

MPX-F Floats

Float Options

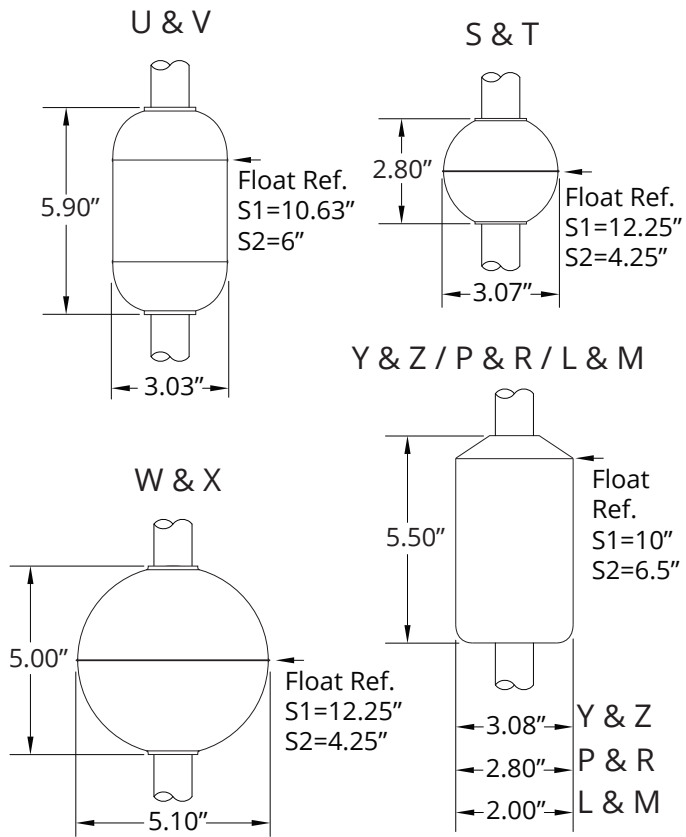

• Specifications

Performance

Resolution	4-20 mA: 14 bit DAC
Accuracy	Modbus: 0.04 in. (1 mm) ±0.05% of Full Scale or 1mm (whichever is larger)

Environmental

Operating Temperature	-40° to 185° F (-40° to 85° C)
Enclosure Protection	NEMA 4X, IP65

Electrical

Supply Voltage	12-24 VDC on sensor
Current Draw	Modbus (RS-485): 28 mA 4-20 mA: 22 mA single / 44 mA dual (Max)

Materials of Construction

Housing	Cast aluminum, epoxy coated
Stem	7/8" ø 316L SS Flexible Tubing with Braid
Mounting (slide)	316L SS
Compression Fitting (slide)	Aluminum with Neoprene bushing

Connectivity

Output	Modbus RTU (RS-485) 2 wire, loop-powered 4-20 mA 3 wire, loop-powered dual 4-20 mA
--------	--

Programming

RS-485	Optional RST-6001 USB-to-RS-485 converter
4-20 mA	Optional RST-4100 programming module

- **Electrical Connections and System Wiring Diagrams**

Modbus System Wiring For MPX-F4 Sensors

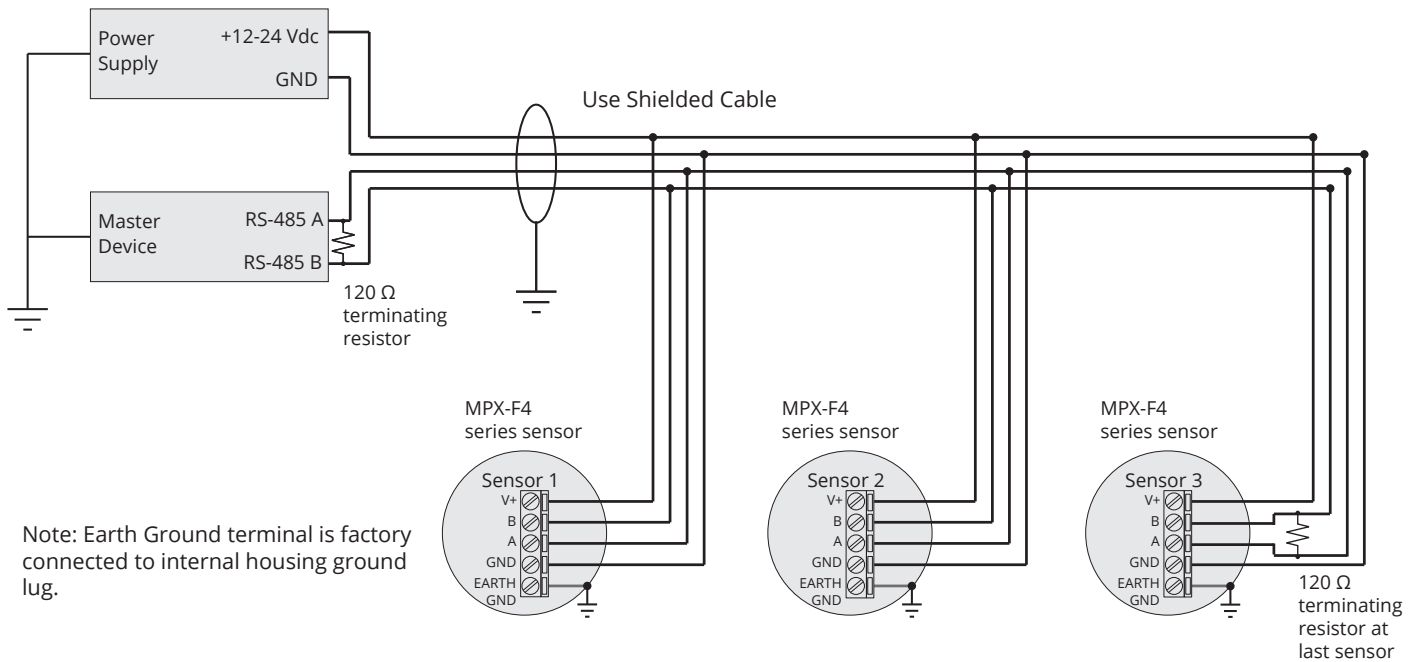

Modbus System Wiring with RST-6001 For MPX-F4 Sensors

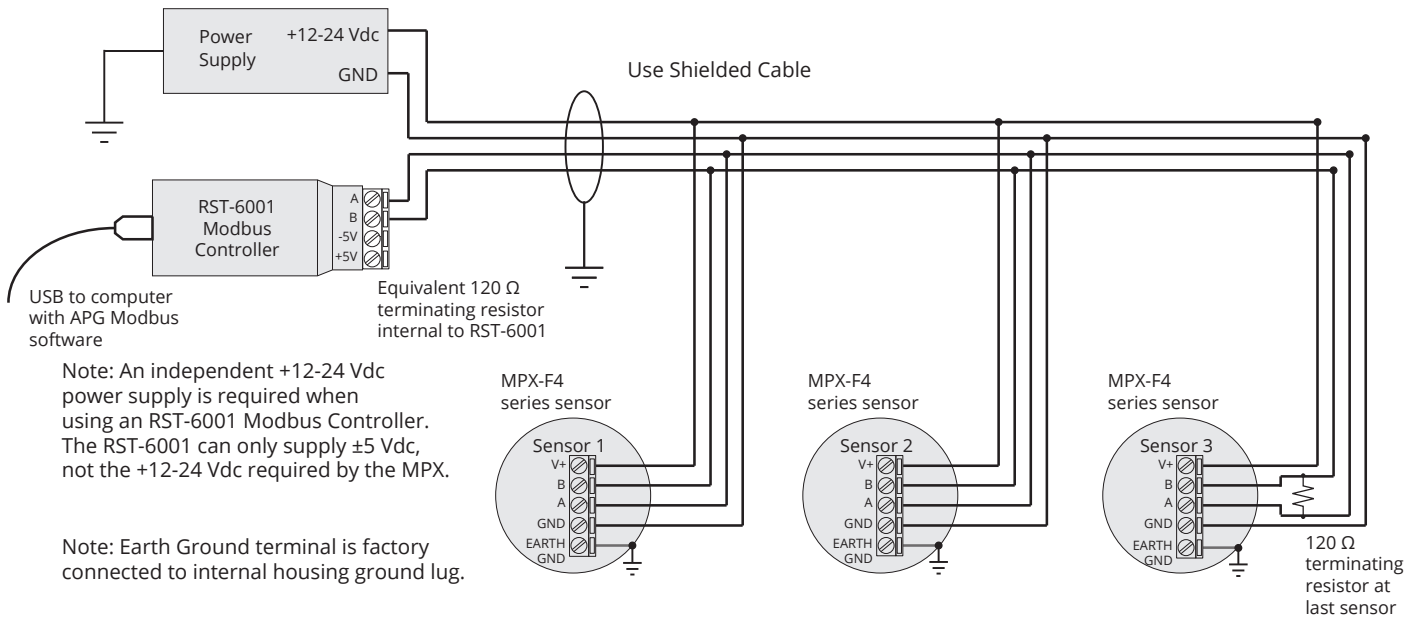

i IMPORTANT: Refer to Chapter 5 for Hazardous Location and Non-Incendive Wiring diagram.

i IMPORTANT: For lightning and surge protection on an MPX-F4, either connect the grounding screw (see page 1) to an earth ground, or ensure that tank mounting of the MPX-F4 is grounded.

4-20 mA Loop Wiring

4-20 mA Single Float Loop Wiring
(MPX-F2 Series)

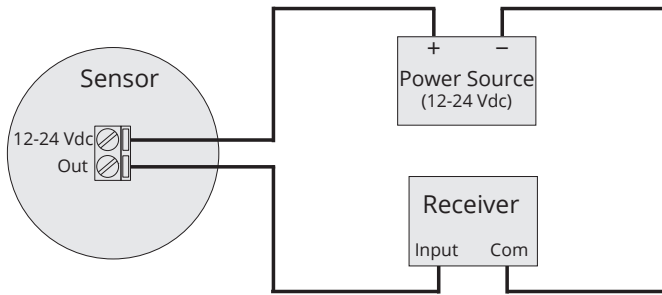

4-20 mA Dual Float Loop Wiring
(MPX-F3 Series)

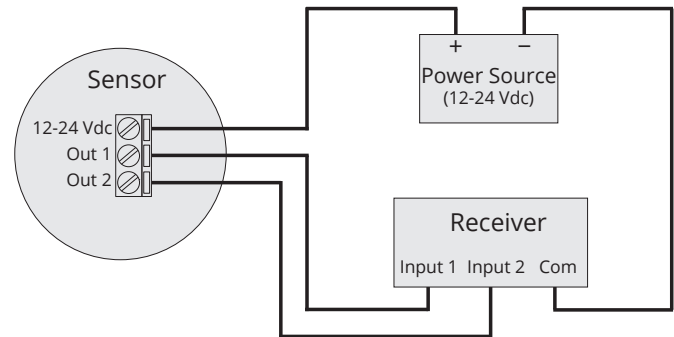

i IMPORTANT: Refer to Chapter 5 for Hazardous Location and Non-Incendive Wiring diagram.

OR

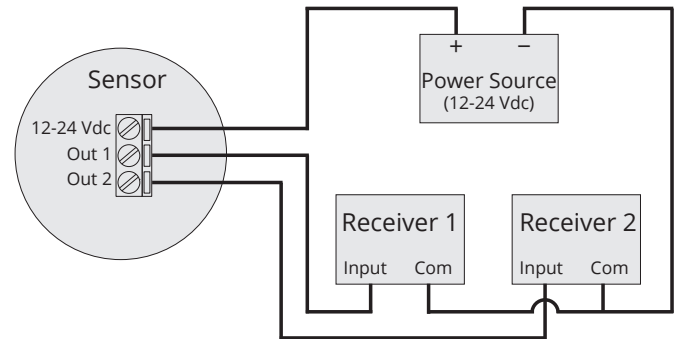

4-20 mA Programming Wiring

Programming configuration is for programming ONLY. After programming, sensor must be reintegrated to 4-20 mA loop for proper system operation.

USB to computer with APG Modbus software

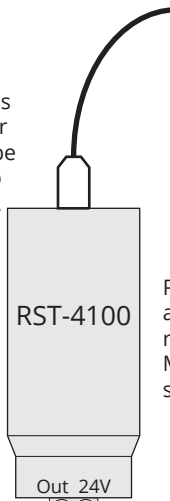

Programming Module and APG Modbus software required for programming MPX-F2 and MPX-F3 series sensors.

MPX-F2 or MPX-F3 series sensor.

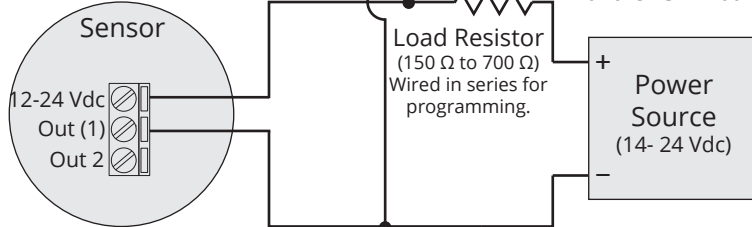

Note: a minimum of 14 Vdc is required to establish communications with the RST-4100

🔧 NOTE: For MPX-F3 series sensors, - Vdc from power source must be connected to Output1 on sensor for correct sensor programming.

Chapter 2: Installation and Removal Procedures and Notes

• Tools Needed

You will need the following tools to install your MPX level sensor:

- Wrench sized appropriately for MPX mounting
- Wrench sized appropriately for conduit connections
- Flat-head screwdriver for wire terminals
- Channel lock pliers for tightening compression fitting
- 1/8" Hex Allen wrench for screws on float stop(s).
- Pliers for bending cotter pin.

• Physical Installation Notes

The MPX-T should be installed in an area--indoors or outdoors--which meets the following conditions:

- Ambient temperature between -40°C and 85°C (-40°F to +185°F)
- Relative humidity up to 100%
- Altitude up to 2000 meters (6560 feet)
- IEC-664-1 Conductive Pollution Degree 1 or 2
- IEC 61010-1 Measurement Category II
- No chemicals corrosive to stainless steel (such as NH₃, SO₂, Cl₂)
- Ample space for maintenance and inspection

Additional care must be taken to ensure:

- The probe is located away from strong magnetic fields, such as those produced by motors, transformers, solenoid valves, etc.
- The medium is free from metallic substances and other foreign matter.
- The probe is not exposed to excessive vibration.
- The float(s) fit through the mounting hole. If the float(s) does/do not fit, it/they must be mounted on the stem from inside the vessel being monitored.
- The float(s) is/are oriented properly on the stem (See Figure 2.1). MPX-F floats are installed by customer.

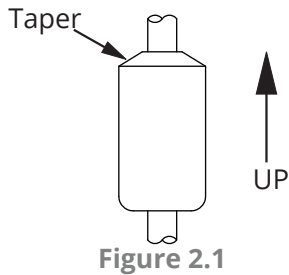

Figure 2.1

i IMPORTANT: Floats must be oriented properly on the stem, or sensor readings will be inaccurate and unreliable. Untapered floats will have a sticker indicating the top of the float. Remove sticker prior to use.

i IMPORTANT: MPX-F level sensor MUST be installed according to drawing 9003468 (Hazardous Installation and Non-Incendive Wiring Drawing) on page 30 to meet listed approvals. Faulty installation will invalidate all safety approvals and ratings.

• Physical Installation Instructions

Ensure that all components have been received, including:

- MPX-F sensor head and stem
- Float (or floats, if two floats purchased)
- Optional Slide Mount
- Weight, Clevis Pin, and Cotter Pin
- Assembly drawing

Assemble sensor mounting, float(s), weight and pins at installation location, if possible.

- Slide mounting option onto stem. Loosen compression cap so it will slide easily on stem.
- Note: If the floats do not fit through the tank/vessel mounting hole, mount them on the stem from inside the vessel being monitored. Then secure the sensor to the vessel.
- Slide floats onto stem. If using two floats, slide the lighter float on first. Tops of floats will be indicated by sticker. After ensure top of float is toward MPX-F sensor head, remove sticker.
- For sensors with float stops, refer to the assembly drawing included with the sensor for float stop installation locations.
- Insert weight on end of stem. Hold in place with clevis pin.
- Insert cotter pin in clevis pin. Bend ends of cotter pin back to lock pins into place.

Install MPX-F sensor on tank

- When lifting and installing the sensor be sure to minimize the bending angle between the rigid stem at the top and bottom of the sensor and the flexible stem in-between. Sharp bends at those points could damage the sensor.
- If your sensor's stem and floats fit through the mounting hole, insert the weight and the floats into the mount opening.
- Carefully unroll and feed the MPX-F sensor stem into the tank. Slide the mount up to the top of the stem.
- When the weight is on the bottom of the tank, secure the mounting option to the vessel.
- Take any slack out of the flexible stem. Tighten the compression fitting to hold stem in place.

- **Electrical Installation**

- Remove the housing cover of your MPX.
- Install conduit fitting(s) to 3/4" NPT conduit opening(s) on housing. Fittings must be UL/CSA Listed for CSA installation.
- Feed system wires into MPX through conduit.
- Connect wires to MPX terminals. Use crimped ferruls on wires, if possible.
- Replace the housing cover.
- For lightning and surge protection on an MPX-F4, either connect the grounding screw (see page 1) to an earth ground, or ensure that tank mounting of the MPX-F4 is grounded.

See Electrical Connections and System Wiring Diagrams (pages 5-6) for Modbus and 4-20 mA wiring examples.

- **Removal Instructions**

Removing your MPX level sensor from service should be done with care.

- If the floats on your sensor fit through the mounting hole, carefully lift the entire sensor assembly out of and away from the vessel.
- If the floats on your sensor do not fit through the mounting hole, they will need to be removed from the stem before the sensor can be removed. Be sure to drain the vessel being monitored to allow access to the floats and stem for removal.
- Clean the stem and floats of any build up or debris and inspect for damage.
- Store your sensor in a dry place, at a temperature between -40° F and 180° F.

Chapter 3: Programming

- **Modbus Programming**

MPX-F4 series sensors use standard Modbus RTU protocol (RS-485). The sensors can only operate as slave devices. Sensor default transmission settings are **9600 Baud, 8 Bits, 1 Stop Bit, No Parity**, and require a minimum delay of 300 ms between transactions. See MPX-F4 Modbus Register Lists on pages 11 and 12.

 NOTE: For more information about Modbus RTU, please visit www.modbus.org.

- **Modbus Programming with RST-6001 and APG Modbus Software**

An APG RST-6001 Modbus Controller can be used in tandem with APG Modbus software to program and control up to 20 MPX-F4 series sensors. Through APG Modbus, you can monitor the raw readings from the sensor, configure the data for distance, level, volume, or weight, and enter measurements for a strapping chart. See MPX-F4 Modbus Register Lists on pages 11 and 12.

 NOTE: For APG Modbus programming instructions, or to download APG Modbus software, please visit www.apgsensors.com/support.

- **4-20 mA Programming with RST-4100 and APG Modbus Software**

An APG RST-4100 Programming Module can be used in tandem with APG Modbus software to program a single MPX-F2/3 series sensor. Through APG Modbus, you can configure the 4 mA and 20 mA output setpoints and calibration settings. If your monitoring equipment (PLC, etc.) can be configured to interpret the 4-20 mA output(s) of the MPX as volume, then the MPX can be configured accordingly via APG Modbus. See MPX-F2 and F3 Modbus Register Lists on pages 17 and 18.

However, the RST-4100 is not designed to be used for continuous monitoring of a sensor. After programming your MPX sensor, the RST-4100 must be removed and the wiring returned to normal. See 4-20 mA Loop Wiring and 4-20 mA Programming Wiring on page 6.

- **Modbus Register Lists for MPX-F4**

Input Registers (0x04)

<u>Register</u>	<u>Returned Data</u>
30300	Raw Top Float Reading (in mm, unsigned)
30301	Raw Bottom Float Reading (in mm, unsigned)
30302	Temperature Reading (in °C, signed)
30303-30304	Calculated Top Float Reading (in selected Units)
30305-30306	Calculated Bottom Float Reading (in selected Units)
30307	Version

 **NOTE:** The Calculated Readings will be returned without a decimal place. In order to obtain the true result, the Decimal Place setting must be taken into account.

Holding Registers (0x03)

Register	Function	Value Range
40400	Device Address	1 to 247
40401	Units	1, 2, 3
40402	Application Type	0, 1, 2, 3, 4, 5, 6, 7, 8, 9, 10, 11
40403	Volume Units	1, 2, 3, 4, 5, 6, 7
40404	Decimal Place	0, 1, 2, 3
40405	†Max Distance	0 to 11,278 mm
40406	Full Distance	0 to 10,364 mm
40407	Empty Distance	0 to 11,278 mm
40408	†Sensitivity	0 to 100
40409	†Pulses	0 to 20
40410	†Blanking	0 to 10,364 mm
40411	NA	NA
40412	†Averaging	1 to 31
40413	†Filter Window	0 to 10,364 mm
40414	†Out of Range Samples	1 to 255
40415	†Sample Rate	10 to 1,000 msec.
40416	†Multiplier	1 to 1,999 (1000 = 1.000)
40417	†Offset	-10,364 to 10,364 mm
40418	†Pre filter	0 to 10,364 mm
40419	†Noise limit	0 to 255
40420	Temperature Select	0 to 8*
40421	†RTD Offset (°C)	-100 to 100
40422	†Float Window	0 to 1,000 mm 0=1 float
40423	†1st Float Offset	-10,364 to 10,364
40424	†2nd Float Offset	-10,364 to 10,364
40425	†Gain Offset	0 to 255
40426	4 mA Set Point	NA*
40427	20 mA Set Point	NA*
40428	4 mA Calibration	NA*
40429	20 mA Calibration	NA*
40430	t1d	NA*
40431	t1w	NA*
40432	t1t	NA*
40433	t2d	NA*
40434	t2w	NA*
40435	t2t	NA*
40436-40437	Parameter 1 Data	0 to 1,000,000 mm
40438-40439	Parameter 2 Data	0 to 1,000,000 mm
40440-40441	Parameter 3 Data	0 to 1,000,000 mm
40442-40443	Parameter 4 Data	0 to 1,000,000 mm
40444-40445	Parameter 5 Data	0 to 1,000,000 mm

*These registers are not used by the MPX-F4, even though they are labeled in the APG Modbus software.

†Setting is factory calibrated. Do not adjust.

• **MPX-F4 Modbus Sensor Parameters**

40401 - Units

Determines the units of measure for the Calculated Reading when Application Type is set to 0, 1, or 7.

1 = Feet 2 = Inches 3 = Meters

40402 - Application Type

Determines the type of Calculated Reading performed by the sensor.

0 = Distance
1 = Level
2 = Standing Cylindrical Tank with or without Hemispherical Bottom
3 = Standing Cylindrical Tank with or without Conical Bottom
4 = Standing Rectangular Tank with or without Chute Bottom
5 = Horizontal Cylindrical Tank with or without Spherical Ends
6 = Spherical Tank
7 = Pounds (Linear Scaling)
8 = N/A
9 = Vertical Oval Tank
10 = Horizontal Oval Tank
11 = Strapping Chart

See MPX-F Modbus Application Type Parameters pages 25-29.

40403 - Volume Units

Determines the units of measure for the Calculated Reading when Application Type is set to 2 - 6 or 9 -11.

1 = Feet³ 5 = Liters
2 = Million Feet³ 6 = Inches³
3 = Gallons 7 = Barrels
4 = Meters³

40404 - Decimal Place

Determines the number of decimal places included in the Calculated Reading(s). The Calculated Reading will always be returned as a whole number.

For example, a Calculated Reading of 1126.658 (gallons, ft³, etc.) will be returned as follows:

Decimal Place = 0 Volume = 1127 (rounded to nearest whole number)
Decimal Place = 1 Volume = 11267 (divide by 10 to get true result)
Decimal Place = 2 Volume = 112666 (divide by 100 to get true result)
Decimal Place = 3 Volume = 1126658 (divide by 1000 to get true result)

40405 - Maximum Distance (Factory Calibrated)

Sets the distance (beginning from the Zero Reference) to the point where the sensor will stop looking for float signals, usually the bottom of the stem. A float beyond the Maximum Distance value will not be detected.

40406 - Full Distance

Sets the positive distance (beginning from the sensor Zero Reference) to the point where the monitored vessel is considered full.

40407 - Empty Distance

Sets the positive distance (beginning from the Zero Reference) to the point where the monitored vessel is considered empty (usually the bottom of the stem).

40408 - Sensitivity (Factory Calibrated)

Sets the level of gain that is applied to the returning float signal.

40409 - Pulses (Factory Calibrated)

Controls the duration of the signal being sent down the magnetostrictive wire.

40410 - Blanking (Factory Calibrated)

Sets the blanking distance, which is the zone from the Zero Reference of the sensor to the point from which the first signal will be valid. Signals from a float in the blanking area will be ignored.

40412 - Averaging (Factory Calibrated)

Sets the number of qualified received float signals to average for the raw reading. Qualified received signals are placed in a first-in, first-out buffer, the contents of which are averaged for the raw reading. The larger the number of qualified received signals being averaged, the smoother the reading will be, and the slower the reading will be to react to quickly changing targets.

40413 - Filter Window (Factory Calibrated)

Determines the physical range (0 - 10,364 mm) of qualified received signals, based on the current raw reading. Signals beyond the +/- Filter Window range of the current reading will not qualify unless the average moves. Signals outside the extents of the Filter Window are written to the Out of Range samples buffer (Holding Register 40414). See Figure 3.1.

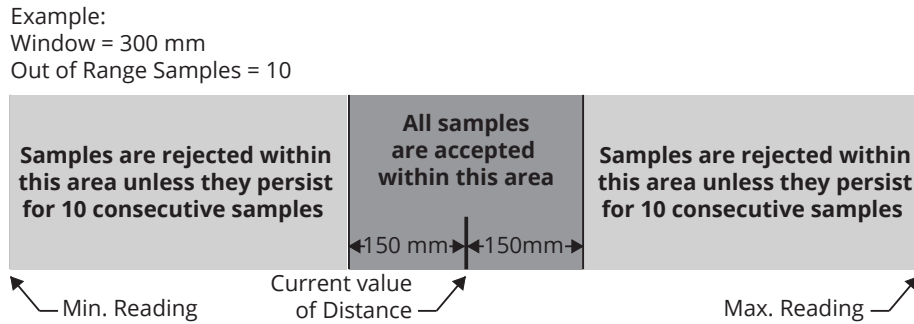

Figure 3.1

40414 - Out of Range Samples (Factory Calibrated)

Sets the number of consecutive samples outside the Filter Window (Holding Register 40413) necessary to automatically adjust the current reading and move the Filter Window.

40415 - Sample Rate (Factory Calibrated)

Sets the update rate of the sensor (between 10 - 1000 ms). Shorter time delays allow for quicker sensor response times to changing levels. Typical setting is 200 ms. Settings under 200 ms are not recommended.

40416 - Multiplier (Factory Calibrated)

Calibrates the distance reading span. The Multiplier is shown by the values 1 - 1999, but these values are understood to represent 0.001 - 1.999. The default of 1000 (i.e. 1.000) is used for most applications.

40417 - Offset (Factory Calibrated)

Sets the Zero Reference of the sensor, the point from which the calculated distance is measured.

40418 - Pre filter

Defines the physical range (0 - 10,364 mm) of the start up (pre-filter) window. Four sample readings must be found within the Pre filter window for the MPX sensor to successfully start up.

This register is used for factory diagnostics only.

40419 - Noise limit

Sets the limit for number of signals (0-255) outside the Pre filter range for the MPX at start up. If the Noise Limit is reached before four readings register within the Pre filter window, the MPX will not start up.

This register is used for factory diagnostics only.

40420 - Temperature Select

Selects the temperature sensor reading to be displayed in Input Register 30302.

MPX-F4 sensors can accommodate up to five digital temperature sensors in the stem. Options 0-5 and 8 will work for MPX-F4 sensors.

- | | |
|----------------------------------|---|
| 0 = RTD | 5 = Digital Temperature Sensor E |
| 1 = Digital Temperature Sensor A | 6 = |
| 2 = Digital Temperature Sensor B | 7 = |
| 3 = Digital Temperature Sensor C | 8 = Digital Temperature Sensor on Circuit Board |
| 4 = Digital Temperature Sensor D | |

40421 - RTD Offset C° (Factory Calibrated)

Calibrates the RTD temperature sensor.

40422 - Float Window (Factory Calibrated)

Sets the distance (0 - 1000 mm) between the first (i.e. top) float and the point at which the sensor will begin looking for the second (bottom) float. 0 indicates a single float.

40423 - 1st Float Offset (Factory Calibrated)

Used to calibrate top float reading (-10,364 - 10,364 mm).

40424 - 2nd Float Offset (Factory Calibrated)

Used to calibrate bottom float reading (-10,364 - 10,364 mm).

40425 - Gain Offset (Factory Calibrated)

Used to move the centerline of the float response signal to optimize signal strength (0 - 255).

• APG Modbus Register Lists for MPX-F2 and MPX-F3

Input Registers (0x04)

<u>Register</u>	<u>Returned Data</u>
30300	Raw Top Float Reading (in mm, unsigned)
30301	Raw Bottom Float Reading (in mm, unsigned)
30302	Temperature Reading (in °C, signed)
30303-30304	Calculated Top Float Reading (in selected Units)
30305-30306	Calculated Bottom Float Reading (in selected Units)
30307	Version

 NOTE: Input Register values for MPX-F2 and MPX-F3 are only visible while programming via the RST-4100.

Holding Registers (0x03)

<u>Register</u>	<u>Function</u>	<u>Value Range</u>
40400	Device Address	1 to 247*
40401	Units	1, 2, 3
40402	Application Type	0, 1, 2, 3, 4, 5, 6, 7, 8, 9, 10, 11
40403	Volume Units	1, 2, 3, 4, 5, 6, 7
40404	Decimal Place	0, 1, 2, 3*
40405	†Max Distance	0 to 10,364 mm
40406	Full Distance	0 to 10,364 mm
40407	Empty Distance	0 to 10,364 mm
40408	†Sensitivity	0 to 100
40409	†Pulses	0 to 20
40410	†Blanking	0 to 10,364 mm
40411	Fail Safe	0 = Disable, 1 = 3.8 mA, 2 = 22 mA
40412	†Averaging	1 to 31
40413	†Filter Window	0 to 10,364 mm
40414	†Out of Range Samples	1 to 255
40415	†Sample Rate	10 to 1,000 msec.
40416	†Multiplier	1 to 1,999 (1000 = 1.000)
40417	†Offset	-10,364 to 10,364 mm
40418	†Pre filter	0 to 10,364 mm
40419	†Noise limit	0 to 255
40420	NA	NA
40421	†RTD Offset (°C)	-100 to 100
40422	†Float Window	0 to 1,000 mm 0=1 float
40423	†1st Float Offset	-10,364 to 10,364
40424	†2nd Float Offset	-10,364 to 10,364
40425	†Gain Offset	0 to 255
40426	4 mA Set Point	0 - 10,364 mm
40427	20 mA Set Point	0 - 10,364 mm
40428	†4 mA Calibration	0 - 1,000
40429	†20 mA Calibration	0 - 1,000
40430	t1d	NA*
40431	t1w	NA*
40432	t1t	NA*
40433	t2d	NA*
40434	t2w	NA*
40435	t2t	NA*
40436-40437	Parameter 1 Data	0 to 1,000,000 mm
40438-40439	Parameter 2 Data	0 to 1,000,000 mm
40440-40441	Parameter 3 Data	0 to 1,000,000 mm
40442-40443	Parameter 4 Data	0 to 1,000,000 mm
40444-40445	Parameter 5 Data	0 to 1,000,000 mm

*These registers are not used by the MPX-F2 or MPX-F3, even though they are labeled in the APG Modbus software.

†Setting is factory calibrated. Do not adjust.

• **MPX-F2 and MPX-F3 APG Modbus Sensor Parameters**

40401 - Units

Determines the units of measure for the Calculated Reading when Application Type is set to 0, 1, or 7.

1 = Feet 2 = Inches 3 = Meters

For MPX-F2 and MPX-F3, this is seen only when using APG Modbus to program the MPX. This setting does not affect the 4-20 mA output.

40402 - Application Type

Determines the type of Calculated Reading performed by the sensor.

0 = Distance

1 = Level

2 = Standing Cylindrical Tank with or without Hemispherical Bottom

3 = Standing Cylindrical Tank with or without Conical Bottom

4 = Standing Rectangular Tank with or without Chute Bottom

5 = Horizontal Cylindrical Tank with or without Spherical Ends

6 = Spherical Tank

7 = Pounds (Linear Scaling)

8 = N/A

9 = Vertical Oval Tank

10 = Horizontal Oval Tank

11 = Strapping Chart

See MPX-F Modbus Application Type Parameters pages 24-28.

For the MPX-F2 and MPX-F3, the 4-20 mA output can be scaled for linear output over distance/level or scaled for linear output over volume. When setup in any of the volumetric application types, the 4-20mA output becomes linear with regards to the volume (linear mA change per gallon, liter, etc.)

40403 - Volume Units

Determines the units of measure for the Calculated Reading when Application Type is set to 2 - 6 or 9 -11.

1 = Feet³

5 = Liters

2 = Million Feet³

6 = Inches³

3 = Gallons

7 = Barrels

4 = Meters³

40404 - Decimal Place

Determines the number of decimal places included in the Calculated Reading(s). For MPX-F2 and -F3, this is seen only when using APG Modbus to program the MPX. This setting does not affect the 4-20 mA output.

40405 - Maximum Distance (Factory Calibrated)

Sets the distance (beginning from the Zero Reference) to the point where the sensor will stop looking for float signals, usually the bottom of the stem. A float beyond the Maximum Distance value will not be detected.

40406 - Full Distance

Sets the positive distance (beginning from the sensor Zero Reference) to the point where the monitored vessel is considered full.

40407 - Empty Distance

Sets the positive distance (beginning from the Zero Reference) to the point where the monitored vessel is considered empty (usually the bottom of the stem).

40408 - Sensitivity (Factory Calibrated)

Sets the level of gain that is applied to the returning float signal.

40409 - Pulses (Factory Calibrated)

Controls the duration of the signal being sent down the magnetostrictive wire.

40410 - Blanking (Factory Calibrated)

Sets the blanking distance, which is the zone from the Zero Reference of the sensor to the point from which the first signal will be valid. Signals from a float in the blanking area will be ignored.

40411 - Fail Safe

Sets the output condition that the MPX-F will revert to in the event of a loss of return signal condition.

0 = Disable (no fail safe output)

1 = 3.8 mA

2 = 22 mA

40412 - Averaging (Factory Calibrated)

Sets the number of qualified received float signals to average for the raw reading. Qualified received signals are placed in a first-in, first-out buffer, the contents of which are averaged for the raw reading. The larger the number of qualified received signals being averaged, the smoother the reading will be, and the slower the reading will be to react to quickly changing targets.

40413 - Filter Window (Factory Calibrated)

Determines the physical range (0 - 10,364 mm) of qualified received signals, based on the current raw reading. Signals beyond the +/- Filter Window range of the current reading will not qualify unless the average moves. Signals outside the extents of the Filter Window are written to the Out of Range samples buffer (Holding Register 40414). See Figure 3.2.

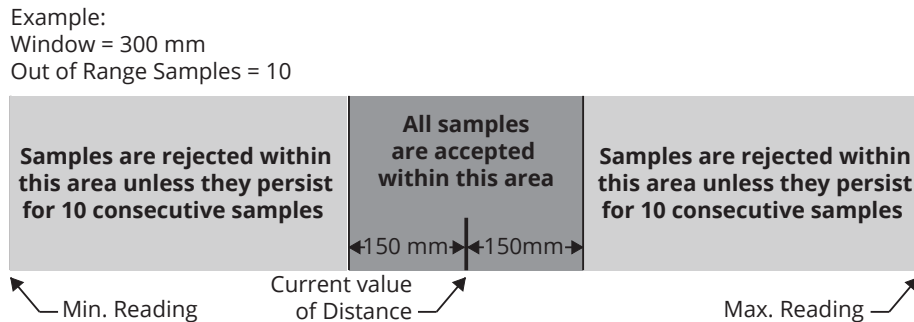

Figure 3.2

40414 - Out of Range Samples (Factory Calibrated)

Sets the number of consecutive samples outside the Filter Window (Holding Register 40413) necessary to automatically adjust the current reading and move the Filter Window.

40415 - Sample Rate (Factory Calibrated)

Sets the update rate the sensor (10 - 1000 ms). Shorter time delays allow for quicker sensor response times to changing levels. Typical setting is 200 ms. Settings under 200 ms are not recommended.

40416 - Multiplier (Factory Calibrated)

Calibrates the distance reading span. The Multiplier is shown by the values 1 - 1999, but these values are understood to represent 0.001 - 1.999. The default of 1000 (i.e. 1.000) is used for most applications.

40417 - Offset (Factory Calibrated)

Sets the Zero Reference of the sensor, the point from which the calculated distance is measured.

40418 - Pre filter

Defines the physical range (0 - 10,364 mm) of the start up (pre-filter) window. Four sample readings must be found within the Pre filter window for the MPX sensor to successfully start up.

This register is used for factory diagnostics only.

40419 - Noise limit

Sets the limit for number of signals (0-255) outside the Pre filter range for the MPX at start up. If the Noise Limit is reached before four readings register within the Pre filter window, the MPX will not start up.

This register is used for factory diagnostics only.

40421 - RTD Offset C° (Factory Calibrated)

Calibrates the RTD temperature sensor.

40422 - Float Window (Factory Calibrated)

Sets the distance (0 - 1000 mm) between the first (i.e. top) float and the point at which the sensor will begin looking for the second (bottom) float. This essentially functions as a secondary blanking distance for the minimum depth of the top fluid. Set to 0 for single float.

40423 - 1st Float Offset (Factory Calibrated)

Used to calibrate top float reading (-10,364 - 10,364 mm).

40424 - 2nd Float Offset (Factory Calibrated)

Used to calibrate bottom float reading (-10,364 - 10,364 mm).

40425 - Gain Offset (Factory Calibrated)

Used to move the centerline of the float response signal to optimize signal strength (0 - 255).

40426 - 4mA Set

Used to set the distance which will correspond to an output of 4 mA. For Application 1 (Distance), this is measured from the Zero Reference. For all other applications (Level & Volumetric) this is measured from the bottom of the probe.

40427 - 20mA Set

Used to set the distance which will correspond to an output of 20 mA. For Application 1 (Distance), this is measured from the Zero Reference. For all other applications (Level & Volumetric) this is measured from the bottom of the probe.

40428 - 4mA Cal (Factory Calibrated)

Used to calibrate the 4 mA output of the MPX-F2 or -F3.

40429 - 20mA Cal (Factory Calibrated)

Used to calibrate the 20 mA output of the MPX-F2 or -F3.

- **MPX-F Modbus Application Type Parameters**

Application 0 - Distance

<u>Register</u>	<u>Function</u>	<u>Value Range</u>
40400	Device Address	1 to 247
40401	Units	1 = Feet, 2 = Inches, 3 = Meters
40402	Application Type	0
40403	Volume Units	--
40404	Decimal (Calculated)	0 - 3

Application 1 - Level

<u>Register</u>	<u>Function</u>	<u>Value Range</u>
40400	Device Address	1 to 247
40401	Units	1 = Feet, 2 = Inches, 3 = Meters
40402	Application Type	1
40403	Volume Units	--
40404	Decimal (Calculated)	0 - 3
40405	Max Distance	(factory set)
40406	Full Distance	0 - 10,364 mm
40407	Empty Distance	0 - 11,278 mm / 0 - 10,364 mm

Application 2 - Volume of Standing Cylindrical Tank ± Hemispherical Bottom

<u>Register</u>	<u>Function</u>	<u>Value Range</u>
40400	Device Address	1 to 247
40401	Units	--
40402	Application Type	2
40403	Volume Units	1 - 7
40404	Decimal (Calculated)	0 - 3
40405	Max Distance	(factory set)
40406	Full Distance	0 - 10,364 mm
40407	Empty Distance	0 - 11,278 mm / 0 - 10,364 mm
40436-40437	Tank Diameter	0 - 1,000,000 (mm)
40438-40439	Radius of Bottom Hemisphere	0 - 1,000,000 (mm)

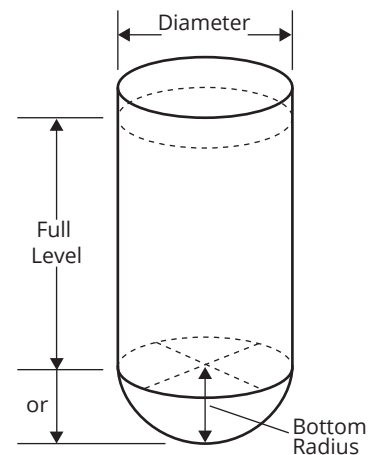

Application 3 - Volume of Standing Cylindrical Tank ± Conical Bottom

<u>Register</u>	<u>Function</u>	<u>Value Range</u>
40400	Device Address	1 to 247
40401	Units	--
40402	Application Type	3
40403	Volume Units	1 - 7
40404	Decimal (Calculated)	0 - 3
40405	Max Distance	(factory set)
40406	Full Distance	0 - 10,364 mm
40407	Empty Distance	0 - 11,278 mm / 0 - 10,364 mm
40436-40437	Tank Diameter	0 - 1,000,000 (mm)
40438-40439	Cone Diameter (at bottom of cone)	0 - 1,000,000 (mm)
40440-40441	Length (height) of Cone	0 - 1,000,000 (mm)

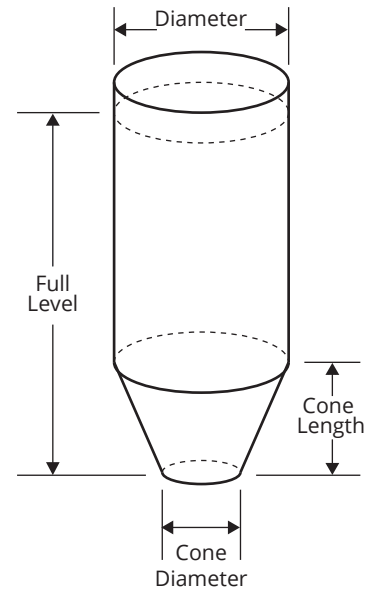

Application 4 - Volume of Standing Rectangular Tank ± Chute Bottom

<u>Register</u>	<u>Function</u>	<u>Value Range</u>
40400	Device Address	1 to 247
40401	Units	--
40402	Application Type	4
40403	Volume Units	1 - 7
40404	Decimal (Calculated)	0 - 3
40405	Max Distance	(factory set)
40406	Full Distance	0 - 10,364 mm
40407	Empty Distance	0 - 11,278 mm / 0 - 10,364 mm
40436-40437	Tank X Dimension	0 - 1,000,000 (mm)
40438-40439	Tank Y Dimension	0 - 1,000,000 (mm)
40440-40441	Chute X Dimension	0 - 1,000,000 (mm)
40442-40443	Chute Y Dimension	0 - 1,000,000 (mm)
40444-40445	Length (height) of Chute	0 - 1,000,000 (mm)

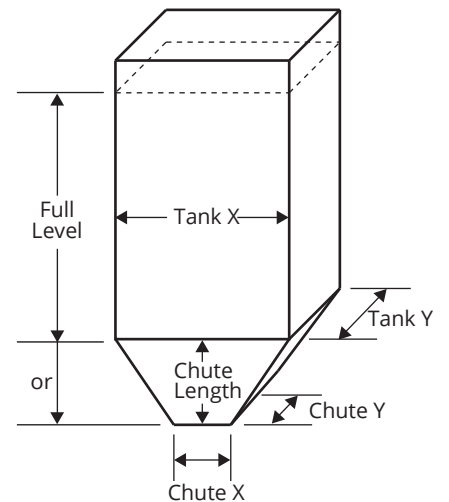

 **NOTE:** For all applications other than Distance, Empty Distance is usually the same as Max Distance.

Application 5 - Volume of Horizontal Cylindrical Tank ± Hemispherical Ends

<u>Register</u>	<u>Function</u>	<u>Value Range</u>
40400	Device Address	1 to 247
40401	Units	--
40402	Application Type	5
40403	Volume Units	1 - 7
40404	Decimal (Calculated)	0 - 3
40405	Max Distance	(factory set)
40406	Full Distance	0 - 10,364 mm
40407	Empty Distance	0 - 11,278 mm / 0 - 10,364 mm
40436-40437	Tank Length	0 - 1,000,000 (mm)
40438-40439	Tank Diameter	0 - 1,000,000 (mm)
40440-40441	Radius of End Hemispheres	0 - 1,000,000 (mm)

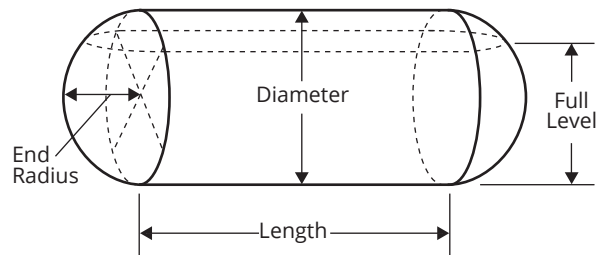

Application 6 - Volume of Spherical Tank

<u>Register</u>	<u>Function</u>	<u>Value Range</u>
40400	Device Address	1 to 247
40401	Units	--
40402	Application Type	6
40403	Volume Units	1 - 7
40404	Decimal (Calculated)	0 - 3
40405	Max Distance	(factory set)
40406	Full Distance	0 - 10,364 mm
40407	Empty Distance	0 - 11,278 mm / 0 - 10,364 mm
40436-40437	Tank Diameter	0 - 1,000,000 (mm)

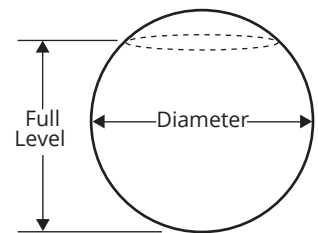

Application 7 - Pounds (Linear Scaling)

<u>Register</u>	<u>Function</u>	<u>Value Range</u>
40400	Device Address	1 to 247
40401	Units	1 = Feet, 2 = Inches, 3 = Meters
40402	Application Type	7
40403	Volume Units	--
40404	Decimal (Calculated)	0 - 3
40405	Max Distance	(factory set)
40406	Full Distance	0 - 10,364 mm
40407	Empty Distance	0 - 11,278 mm / 0 - 10,364 mm
40436-40437	Multiplier (linear scalar)	0 - 1,000,000 (1000 = 1.000)

Application 8 - N/A

Application 9 - Volume of Vertical Oval Tank

<u>Register</u>	<u>Function</u>	<u>Value Range</u>
40400	Device Address	1 to 247
40401	Units	--
40402	Application Type	9
40403	Volume Units	1 - 7
40404	Decimal (Calculated)	0 - 3
40405	Max Distance	(factory set)
40406	Full Distance	0 - 10,364 mm
40407	Empty Distance	0 - 11,278 mm / 0 - 10,364 mm
40436-40437	Tank Length	0 - 1,000,000 (mm)
40438-40439	Tank Depth	0 - 1,000,000 (mm)
40440-40441	Tank Width	0 - 1,000,000 (mm)

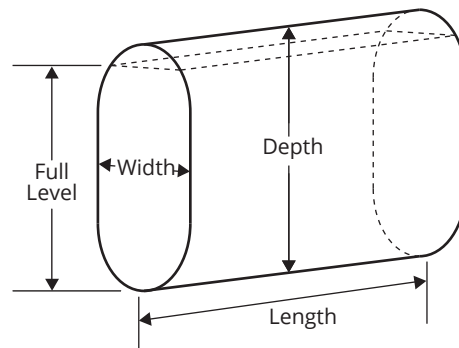

Application 10 - Volume of Horizontal Oval Tank

<u>Register</u>	<u>Function</u>	<u>Value Range</u>
40400	Device Address	1 to 247
40401	Units	--
40402	Application Type	10
40403	Volume Units	1 - 7
40404	Decimal (Calculated)	0 - 3
40405	Max Distance	(factory set)
40406	Full Distance	0 - 10,364 mm
40407	Empty Distance	0 - 11,278 mm / 0 - 10,364 mm
40436-40437	Tank Length	0 - 1,000,000 (mm)
40438-40439	Tank Depth	0 - 1,000,000 (mm)
40440-40441	Tank Width	0 - 1,000,000 (mm)

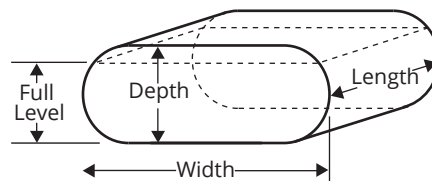

Application 11 - Strapping Chart (Polynomial Values)

<u>Register</u>	<u>Function</u>	<u>Value Range</u>
40400	Device Address	1 to 247
40401	Units	1 = Feet, 2 = Inches, 3 = Meters
40402	Application Type	11
40403	Volume Units	1 - 7
40404	Decimal (Calculated)	0 - 3
40405	Max Distance	(factory set)
40406	Full Distance	0 - 10,364 mm
40407	Empty Distance	0 - 11,278 mm / 0 - 10,364 mm
40436-40437	X ³ Coefficient	0 - 1,000,000
40438-40439	X ² Coefficient	0 - 1,000,000
40440-40441	X ¹ Coefficient	0 - 1,000,000
40442-40443	X ⁰ Coefficient	0 - 1,000,000

Chapter 4: Maintenance

- **General Care**

Your MPX level sensor is designed to be low maintenance. However, in general, you should:

- Periodically inspect your MPX to ensure the stem and floats are free of any heavy buildup that might impede the movement of the floats.
- Ensure the housing cover is snugly secured. If the cover becomes damaged or is misplaced, order a replacement immediately.

- **Repair and Returns**

Should your MPX level sensor require service, please contact the factory via phone, email, or online chat. We will issue you a Return Material Authorization (RMA) number with instructions.

- Phone: 888-525-7300
- Email: sales@apgsensors.com
- Online chat at www.apgsensors.com

Please have your part number and serial number available. See Warranty and Warranty Restrictions for more information.

i **IMPORTANT:** All repairs and adjustments of the MPX level sensor must be made by the factory. Modifying, disassembling, or altering the MPX on site is strictly prohibited.

- **CSA Certificate of Compliance**



Certificate of Compliance

Certificate: 2397437 (237484)

Master Contract: 237484

Project: 70022593

Date Issued: 2016-04-22

Issued to: Automation Products Group Inc
1025 West 1700 North
Logan, Utah 84321
USA
Attention: Karl Reid

The products listed below are eligible to bear the CSA Mark shown with adjacent indicators 'C' and 'US' for Canada and US or with adjacent indicator 'US' for US only or without either indicator for Canada only.



Issued by: Ravindra
(Ravi) Kanthe
Ravindra (Ravi)
Kanthe

PRODUCTS

CLASS - C225802 - PROCESS CONTROL EQUIPMENT-For Hazardous Locations-

CLASS - C225882 - PROCESS CONTROL EQUIPMENT-For Hazardous Locations - Certified to US Standards

Class I, Division 1 & 2, Groups C and D

Ex d IIB

Ex nA IIB

Class I, Zone 1; AEx d IIB

Class I, Zone 2; AEx nA IIB

- Float Level Sensors, Model MPX- E, R, G & T (MPX- abc-de-fghi-jjj), rated 12 - 24 Vdc, 80mA, or rated 12 to 24 Vdc, 4-20mA; operating ambient Ta is 85°C; Temperature Code T4; Ingress protection IP65; Field wiring is non-incendive when installed per drawing 9003468.

Class I, Division 2, Groups C and D

Ex nA IIB

Class I, Zone 2; AEx nA IIB



Certificate: 2397437
Project: 70022593

Master Contract: 237484
Date Issued: 2016-04-22

- Float Level Sensors, Model MPX- F (model MPX- abc-de-fghi-jjj), rated 12 - 24 Vdc, 80mA, or rated 12 to 24 Vdc, 4-20mA; operating ambient Ta is 85°C; Temperature Code T4; Ingress protection IP65; Field wiring is non-incendive when installed per drawing 9003468

Notes for all equipment:

1. The model code breakdown is as follows: a= E, R, F, G or T; b= 1, 2, 3 or 4; c= A,B or C, d= A, B, C, D, E, F, G, Z, X, V, T, R, M, or J; e= N, B, D, Y, W, U, S, P, L, K, or I; f= F, R, P, S, N, or O; g= 1, 1.5, 2, 2.5, 3, 3.5, 4, 5, 6; h=W or S; i= A, B, C or D; and j= 12–153 for the 1/2" stem Type E or 48–300 for the 1" stem Type R, Type G and Type T or 120-456 for Flex stem Type F.
2. The equipment is intended to be installed as required by the applicable electrical code (CEC, NEC) and as specified by the manufacturers Installation Instructions.
3. The installation will be inspected by the authority with jurisdiction in the area where installed.

APPLICABLE REQUIREMENTS

CSA C22.2 No 0-10	General Requirements – Canadian Electrical Code, Part II – Tenth Edition
CSA C22.2 No 30-M1986 (Reaffirmed 2007)	Explosion-Proof Enclosures for Use in Class I Hazardous Locations Industrial Products – Third Edition
CSA C22.2 No 142-M1987 (Reaffirmed 2014)	Process Control Equipment Industrial Products – Third Edition
CSA C22.2 No 213-M1987 (Reaffirmed 2008)	Non-incendive Electrical Equipment for Use in Class I, Division 2 Hazardous Locations Industrial Products – First Edition
CSA C22.2 No 60079-0-07	Electrical apparatus for explosive gas atmospheres – Part 0: General requirements – First Edition
CSA C22.2 No 60079-1-07	Electrical apparatus for explosive gas atmospheres – Part 1: Flameproof enclosures "d" – First Edition
CSA E60079-15-02 (Reaffirmed 2006)	Electrical Apparatus for Explosive Gas Atmospheres – Part 15: Type of Protection "n" – Second Edition
UL 508	Industrial Control Equipment - Seventeenth Edition; Reprint with Revisions Through and Including April 15, 2010
UL 1203	Explosion-Proof and Dust-Ignition-Proof Electrical Equipment for Use in Hazardous (Classified) Locations - Fourth Edition; Reprint with Revisions through and Including October 28, 2009
ANSI/ISA-12.12.01-2007	Nonincendive Electrical Equipment for Use in Class I and II, Division 2 and Class III, Divisions 1 and 2 Hazardous (Classified) Locations
UL 60079-0 - 5th Ed (Dec 2009)	Explosive atmospheres - Part 0 Equipment - General requirements



Certificate: 2397437
Project: 70022593

Master Contract: 237484
Date Issued: 2016-04-22

UL 60079-1 - 6th Ed (Apr 2009)	Explosive atmospheres - Part I Equipment Protection by Flameproof Enclosures "d"
UL 60079-15 - 3rd Ed (Oct 2009)	Electrical Apparatus for Explosive Gas Atmospheres - Part 15 - Electrical Apparatus with Type of Protection n

MARKINGS

Please refer to Descriptive report for markings and Instructional material.



Supplement to Certificate of Compliance

Certificate: 2397437 (237484)

Master Contract: 237484

*The products listed, including the latest revision described below,
are eligible to be marked in accordance with the referenced Certificate.*

Product Certification History

Project	Date	Description
70022593	2016-04-22	Update to Report 2397437 to include 3 new Probe types MPX-G, MPX-T (for Class 1, Div. 1 & 2 and Zones 1 & 2) and MPX-F (for Class 1, Div. 2 and Zone 2), new PCB design, and update product label material and printing method.
2440956	2011-07-19	Update to report 2397437 to correct misspellings and add note in Factory Tests section of report.
2397437	2011-05-18	Original certification for the model MPX-ab-cd-efg-hhh float level sensors.



Automation Products Group, Inc.

Tel: 1/888/525-7300 • Fax: 1/435/753-7490 • www.apgsensors.com • sales@apgsensors.com