

Instruction Manual

PN 51-MCL-1056 rev.B

August 2009

Model MCL

Monochloramine Measuring System



ESSENTIAL INSTRUCTIONS

READ THIS PAGE BEFORE PROCEEDING!

Your purchase from Rosemount Analytical, Inc. has resulted in one of the finest instruments available for your particular application. These instruments have been designed, and tested to meet many national and international standards. Experience indicates that its performance is directly related to the quality of the installation and knowledge of the user in operating and maintaining the instrument. To ensure their continued operation to the design specifications, personnel should read this manual thoroughly before proceeding with installation, commissioning, operation, and maintenance of this instrument. If this equipment is used in a manner not specified by the manufacturer, the protection provided by it against hazards may be impaired.

- Failure to follow the proper instructions may cause any one of the following situations to occur: Loss of life; personal injury; property damage; damage to this instrument; and warranty invalidation.
- Ensure that you have received the correct model and options from your purchase order. Verify that this manual covers your model and options. If not, call 1-800-854-8257 or 949-757-8500 to request correct manual.
- For clarification of instructions, contact your Rosemount representative.
- Follow all warnings, cautions, and instructions marked on and supplied with the product.
- Use only qualified personnel to install, operate, update, program and maintain the product.
- Educate your personnel in the proper installation, operation, and maintenance of the product.
- Install equipment as specified in the Installation section of this manual. Follow appropriate local and national codes. Only connect the product to electrical and pressure sources specified in this manual.
- Use only factory documented components for repair. Tampering or unauthorized substitution of parts and procedures can affect the performance and cause unsafe operation of your process.
- All equipment doors must be closed and protective covers must be in place unless qualified personnel are performing maintenance.
- If this equipment is used in a manner not specified by the manufacturer, the protection provided by it against hazards may be impaired.

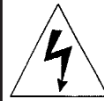

WARNING **RISK OF ELECTRICAL SHOCK**

- Equipment protected throughout by double insulation.
- Installation of cable connections and servicing of this product require access to shock hazard voltage levels.
- Main power and relay contacts wired to separate power source must be disconnected before servicing.
- Do not operate or energize instrument with case open!
- Signal wiring connected in this box must be rated at least 240 V.
- Non-metallic cable strain reliefs do not provide grounding between conduit connections! Use grounding type bushings and jumper wires.
- Unused cable conduit entries must be securely sealed by non-flammable closures to provide enclosure integrity in compliance with personal safety and environmental protection requirements. Unused conduit openings must be sealed with NEMA 4X or IP65 conduit plugs to maintain the ingress protection rating (NEMA 4X).
- Electrical installation must be in accordance with the National Electrical Code (ANSI/NFPA-70) and/or any other applicable national or local codes.
- Operate only with front and rear panels fastened and in place over terminal area.
- Safety and performance require that this instrument be connected and properly grounded through a three-wire power source.
- Proper relay use and configuration is the responsibility of the user.

CAUTION

This product generates, uses, and can radiate radio frequency energy and thus can cause radio communication interference. Improper installation, or operation, may increase such interference. As temporarily permitted by regulation, this unit has not been tested for compliance within the limits of Class A computing devices, pursuant to Subpart J of Part 15, of FCC Rules, which are designed to provide reasonable protection against such interference. Operation of this equipment in a residential area may cause interference, in which case the user at his own expense, will be required to take whatever measures may be required to correct the interference.

WARNING

This product is not intended for use in the light industrial, residential or commercial environments per the instrument's certification to EN50081-2.

Emerson Process Management

Liquid Division

2400 Barranca Parkway
Irvine, CA 92606 USA
Tel: (949) 757-8500
Fax: (949) 474-7250

<http://www.raihome.com>

QUICK START GUIDE

FOR MODEL MCL-220 ANALYZER

1. Refer to Section 2.0 for installation instructions and Section 3.0 for wiring instructions.
2. Once connections are secured and verified, apply power to the analyzer.
3. When the analyzer is powered up for the first time, **Quick Start** screens appear. Using **Quick Start** is easy.
 - a. A backlit field shows the position of the cursor.
 - b. To move the cursor left or right, use the keys to the left or right of the ENTER key. To scroll up or down or to increase or decrease the value of a digit, use the keys above and below the ENTER key. Use the left and right keys to move the decimal point.
 - c. Press ENTER to store a setting. Press EXIT to leave without storing changes. Pressing EXIT also returns the display to the initial Quick Start screen.
 - d. A vertical black bar with a downward pointing arrow on the right side of the screen means there are more items to display. Continue scrolling down to display all the items. When you reach the bottom of the list, the arrow will point up.

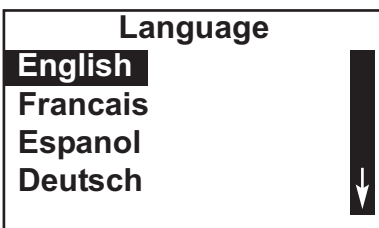

4. Choose the desired language. Scroll down to display more choices.

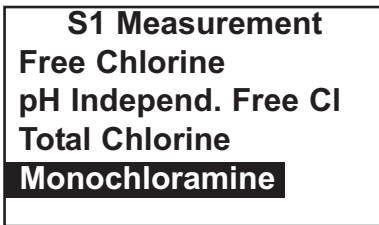

5. Choose monochloramine for sensor 1 (**S1**).

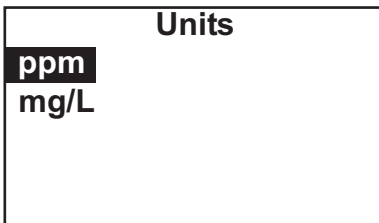

6. Choose the desired units for chlorine.

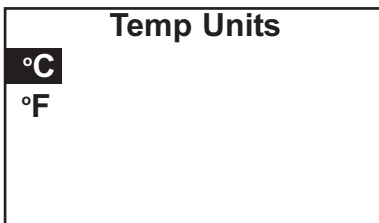

7. Choose the desired temperature units.

8. The main display appears. The outputs and alarms (if an alarm board is present) are assigned to default values.
9. To change outputs, alarms, and other settings go to the main menu and choose **Program**. Follow the prompts. A menu tree is on the following two pages. To calibrate the sensor(s) refer to section 6.0.

MENU TREE

Calibrate

- **Sensor 1 (Monochloramine)**
 - Chlorine
 - Zero
 - In process
 - Temperature
- **Output 1**
- **Output 2**

Hold

- **Sensor 1**

Display

- **Main format configuration**
- **Language selection**
- **Warning (enable or disable)**
- **Screen contrast**

Program

- **Outputs**
 - Range (assign values to 4 and 20 mA)
 - Configure
 - Output 1 or 2
 - Assign sensor and measurement
 - Range
 - Scale
 - Dampening
 - Fault mode (fixed or live)
 - Fault value (output current)
 - Simulate
- **Alarms**
 - Configure/Setpoint
 - Alarm 1, 2, 3, or 4
 - Setpoint
 - Assign sensor and measurement
 - High or low logic
 - Deadband
 - Interval time
 - On time
 - Recovery time
 - Simulate
 - Synchronize timers
- **Measurement**
 - Monochloramine (sensor 1)
 - Measurement selection
 - Units
 - Filter
 - Resolution
- **Temperature**
 - Units
 - Temperature compensation (auto or manual)
 - Set manual temperature (if selected)
- **Security**
 - Calibrate/Hold only
 - All
- **Reset Analyzer**

About This Document

This manual contains instructions for installation and operation of the Model MCL-1056

The following list provides notes concerning all revisions of this document.

<u>Rev. Level</u>	<u>Date</u>	<u>Notes</u>
A	09/08	This is the initial release of the product manual. The manual has been reformatted to reflect the Emerson documentation style and updated to reflect any changes in the product offering.
B	08/09	Update ISO / DNV approval.

MCL-1056

TABLE OF CONTENTS

Section	Title	Page
1.0	DESCRIPTION AND SPECIFICATIONS	1
1.1	Features	1
1.2	Specifications	2
1.3	Ordering Information	3
2.0	INSTALLATION	5
2.1	Unpacking and Inspection.....	5
2.2	Installation.....	5
3.0	WIRING.....	9
3.1	Power, Alarm and Output Wiring.....	9
3.2	Sensor Wiring	10
4.0	DISPLAY AND OPERATION	13
4.1	Display	13
4.2	Keypad.....	14
4.3	Programming the Analyzer - Tutorial.....	15
4.4	Security	16
4.5	Using Hold	17
4.6	Configuring the Main Display	18
5.0	PROGRAMMING THE ANALYZER	19
5.1	General	19
5.2	Default Settings.....	19
5.3	Configuring, Ranging and Simulating Outputs.....	22
5.4	Configuring Alarms and Assigning Setpoints	25
5.5	Configuring the Measurement.....	30
5.6	Configuring Temperature Related Settings	31
5.7	Configuring Security Settings.....	32
5.8	Resetting the Analyzer	33
6.0	CALIBRATION	35
6.1	Introduction	35
6.2	Calibrating Temperature.....	35
6.3	Calibration - Free Chlorine	37
6.4	Calibration - Analog Outputs	40

TABLE OF CONTENTS CONT'D

Section	Title	Page
7.0	MAINTENANCE	41
7.1	Analyzer	41
7.2	Monochloramine Sensor	42
7.3	Constant Head Flow Controller	44
8.0	TROUBLESHOOTING	47
8.1	Overview	47
8.2	Using the Diagnostic Feature.....	47
8.3	Troubleshooting When a Fault Message is Showing	46
8.4	Troubleshooting When a Warning Message is Showing.....	49
8.5	Troubleshooting When No Error Message is Showing	50
8.6	Troubleshooting When No Error Message is Showing - General	53
8.7	Simulating Inputs	53
8.8	Simulating Temperature	54

LIST OF TABLES

Number	Title	Page
5.1	Default Settings	20
5.1	Default Settings cont	21
7.2	Replacement parts for constant head flow controller assembly	45
8.3	Troubleshooting When a Fault Message is Showing	48
8.4	Troubleshooting When a Warning Message is Showing	51
8.5	Troubleshooting When No Error Message is Showing	52
8.6	Troubleshooting When No Error Message is Showing - General.....	55

LIST OF FIGURES

Number	Title	Page
2-1	Model MCL	7
3-1	Analog output connections	9
3-2	Alarm Relay Connections	10
3-3	Wiring Sensor with Optimum EMI/RFI or Variopool Cable to Model 1056 Analyzer ..	11
4-1	Main Display	13
4-2	Programming Screen Showing Item List	13
4-3	Arrow Bar	13
4-4	Analyzer Keypad	14
4.5	Navigation Keys	14
5-1	High Alarm Logic	26
5-2	Low Alarm Logic	26
5-3	Operation of the Interval Timer	26
6-1	Sensor Current as a Function of Monochloramine Concentration	37
6-2	Calibration Slope and Offset	43
7-1	Chlorine Sensor Parts	49
8-2	Monochloramine	55
8-3	Three-Wire RTD Configuration	56
8-4	Simulating RTD Inputs	56

SECTION 1.0. DESCRIPTION AND SPECIFICATIONS

- COMPLETE SYSTEM INCLUDES sensor, connecting cable, analyzer, and flow controller.
- VARIOPOL QUICK-DISCONNECT FITTINGS make replacing sensor easy.
- FEATURE-PACKED ANALYZER: dual outputs, four fully-programmable alarm relays, large back-lit display.

1.1 FEATURES

The Model MCL monochloramine system is intended for the determination of monochloramine in fresh water.

The Model MCL uses a membrane-covered amperometric sensor. A polarizing voltage applied to a gold mesh cathode behind the membrane reduces the monochloramine diffusing through the membrane and keeps the concentration of monochloramine in the sensor equal to zero. The current generated by the cathode reaction is proportional to the rate of diffusion of monochloramine through the membrane. Because the concentration of monochloramine in the sensor is zero, the diffusion rate and the current are proportional to the concentration of monochloramine in the sample.

Diffusion rate also depends on membrane permeability, which is a function of temperature. An RTD in the sensor continuously measures the temperature of the sample and the analyzer automatically corrects the raw sensor current for temperature changes.

Maintenance is fast and easy. Replacing a membrane requires no special tools or fixtures. A screw cap holds the pre-tensioned membrane in place. Replacing the electrolyte solution takes only minutes.

The Model MCL includes the easy-to-use Model 1056 analyzer. The analyzer features two fully programmable 4-20 mA outputs and four fully programmable relays. The large back-lit display allows the user to read monochloramine concentration at a glance.

Valves, rotameters, and pressure regulators to control sample flow are things of the past with the Model MCL. A constant head overflow sampler ensures the correct sample flow to each sensor. To eliminate wiring hassles, quick-disconnect Variopool cable is standard.

Stable monochloramine standards do not exist. The monochloramine sensor must be calibrated using the results of a laboratory test run on a grab sample.

1.2 SPECIFICATIONS — GENERAL

Sample requirements:

Pressure: 3 to 65 psig (122 to 549 kPa abs)
 A check valve in the inlet prevents the sensor flow cells from going dry if sample flow is lost. The check valve opens at 3 psig (122 kPa abs). If the check valve is removed, minimum pressure is 1 psig (108 kPa abs).

Temperature: 32 to 122°F (0 to 50°)

Minimum Flow: 3 gal/hr (11 L/hr)

Maximum flow: 80 gal/hr (303 L/hr); high flow causes the overflow tube to back up.

Sample Conductivity: >10 µS/cm at 25°C

Process connection: ¼-in OD tubing compression fitting (can be removed and replaced with barbed fitting for soft tubing).

Drain connection: ¾-in barbed fitting. Sample must drain to open atmosphere.

Wetted parts:

Overflow sampler: acrylic, nylon, CPVC, Buna N, 316 stainless steel

Monochloramine sensor: Noryl¹, Viton², silicone, and Zitex³, PTFE, gold mesh cathode (not normally wetted)

Response time to step change in monochloramine concentration: <60 sec to 95% of final reading for inlet sample flow of 17 gph (64 L/hr).

Weight/shipping weight: 10 lb/13 lb (4.5 kg/6.0 kg)
[rounded to the nearest 1 lb. (0.5 kg)]

SPECIFICATIONS — SENSOR

Range: 0 to 6 ppm as Cl₂. For higher ranges, consult the factory.

pH range: Response is practically independent of pH between pH 7.0 and 10.0. Sensor current at pH 10.0 is within 5% of sensor current at pH 7.0.

Accuracy: Accuracy depends on the accuracy of the chemical test used to calibrate the sensor.

Linearity: 2% (typ.)

Electrolyte volume: 25 mL (approx.)

Electrolyte life: 2 months (approx.)

¹ Noryl is a registered trademark of General Electric.
² Viton is a registered trademark of E.I. duPont de Nemours & Co.
³ Zitex is a registered trademark of Performance Plastic Corp.

SPECIFICATIONS — ANALYZER

Case: Polycarbonate, NEMA 4X/CSA4 (IP65)

Display: Monochromatic back-lit LCD. Main character height 0.6 in (15 mm). Display is user-programmable.

Languages: English, German, Italian, Spanish, French, Portuguese

Ambient temperature and humidity: 32 to 131°F (0 to 55°C); RH 5 to 95% (con-condensing)

Storage temperature: -4 to 140°F (-20°C and 60°C)

Power: 84 to 265 Vac, 47.5-65.0 Hz, 15 W.

Equipment protected by double insulation.

RFI/EMI: EN-61326



LVD: EN-61010-1

Outputs: Two 4-20 mA or 0-20 mA isolated outputs. Continuously adjustable. Linear or logarithmic. Maximum load 550 ohms. Output dampening with time constant of 5 sec is user-selectable.



Alarms: Four alarm relays for process measurement(s) or temperature. Any relay can be configured as a fault alarm instead of a process alarm. Each relay can be configured independently and each can be programmed with interval timer settings.

Relays: Form C, SPDT, epoxy sealed



	Maximum Relay Current	
	Resistive	Inductive
28 Vdc	5.0 A	3.0 A
115 Vac	5.0 A	3.0 A
230 Vac	5.0 A	1.5 A

Terminal Connections Rating: Power connector (3-leads): 24-12 AWG wire size. Current output connectors (2-leads): 24-16 AWG wire size. Alarm relay terminal blocks: 24-12 AWG wire size

1.3 ORDERING INFORMATION

Model MCL Monochloramine Measuring System. The MCL is a complete system for the determination of monochloramine in water. It consists of the sensor, analyzer, Variopol cable, and constant head overflow cup to control sample flow. All components are mounted on a backplate, and the cable is pre-wired to the analyzer. Three replacement membranes and a 4-oz. bottle of electrolyte solution are shipped with the sensor.

MODEL	DESCRIPTION
MCL-220	Monochloramine Measuring System
MCL-220	EXAMPLE

COMPONENT PARTS

ANALYZER MODEL	DESCRIPTION
1056-03-24-38-AN	1056 analyzer, single input (monochloramine), alarm relays, analog output, 115/230 Vac

SENSOR MODEL	DESCRIPTION
499ACL-03-54-VP	Monochloramine sensor with Variopol connector

SENSOR CABLE	DESCRIPTION
23747-04	Interconnecting cable, Variopol for 499ACL sensor, 4 ft

ACCESSORIES

PART #	DESCRIPTION
9240048-00	Tag, stainless steel (specify marking)

SECTION 2.0. INSTALLATION

2.1 UNPACKING AND INSPECTION

Inspect the shipping container. If it is damaged, contact the shipper immediately for instructions. Save the box. If there is no apparent damage, unpack the container. Be sure all items shown on the packing list are present. If items are missing, notify Rosemount Analytical immediately.

2.1.1 MODEL MCL-220

Model MCL-220 consists of the following items mounted on a back plate.

1. Model 1056-03-24-38-AN analyzer with sensor cable attached.
2. Constant head overflow sampler with flow cell for monochloramine sensor.

The monochloramine sensor (Model 499ACL-03-54-VP), three membrane assemblies, and a bottle of electrolyte solution are in a separate package.

2.2 INSTALLATION

2.2.1 General Information

1. Although the system is suitable for outdoor use, do not install it in direct sunlight or in areas of extreme temperature.

 CAUTION
--

The MCL analyzer is NOT suitable for use in hazardous areas.
--

2. To keep the analyzer enclosure watertight, install plugs (provided) in the unused conduit openings.
3. Install the system in an area where vibrations and electromagnetic and radio frequency interference are minimized or absent.
4. Be sure there is easy access to the analyzer and sensor.

2.2.2 Sample Requirements

Be sure the sample meets the following requirements:

1. Temperature: 32 to 122°F (0 to 50°C)
2. Pressure: 3 to 65 psig (122 to 549 kPa abs)
3. Minimum flow: 3 gal/hr (11 L/hr)

2.2.3 Mounting, Inlet, and Drain Connections

The Model MCL-220 is intended for wall mounting only. Refer to Figure 2-1 for details. The sensor screws into the flow cell adapter.

A 1/4-inch OD tubing compression fitting is provided for the sample inlet. If desired, the compression fitting can be removed and replaced with a barbed fitting. The inlet fitting screws into a 1/4-inch FNPT check valve. The check valve prevents the sensor flow cell from going dry if sample flow is lost.

The sample drains through a 3/4-inch barbed fitting. Attach a piece of soft tubing to the fitting and allow the waste to drain open atmosphere. Do not restrict the drain line.

Remove the foam packing insert between the outer tube and the inner overflow tube. Adjust the sample flow until the water level is even with the central overflow tube and excess water is flowing down the tube.

2.2.4 Electrical Connections

Refer to Section 3.1 for details.

2.2.5 Installing the Sensor

The Model MCL is provided with the sensor cable pre-wired to the analyzer. The terminal end of the sensor is keyed to ensure proper mating with the cable receptacle. Once the key has slid into the mating slot, tighten the connection by turning the knurled ring clockwise.

The sensor screws into a plastic fitting, which is held in the flow cell by a union nut. Do not remove the protective cap on the sensor until ready to put the sensor in service.

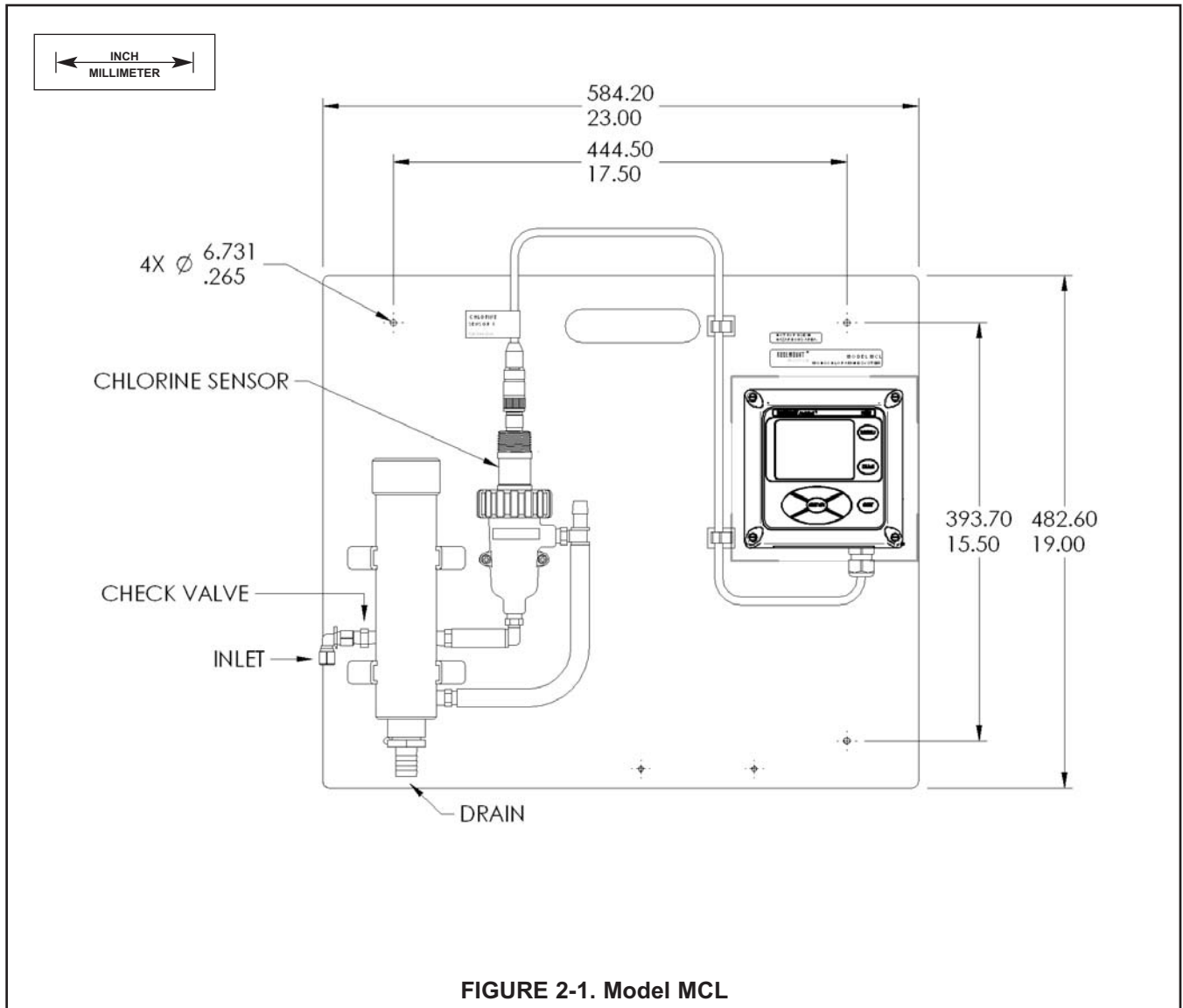

SECTION 3.0.

WIRING

3.1 POWER, ALARM, AND OUTPUT WIRING

	<p>WARNING</p> <p>RISK OF ELECTRICAL SHOCK</p>
<p>Electrical installation must be in accordance with the National Electrical Code (ANSI/NFPA-70) and/or any other applicable national or local codes.</p>	

3.1.1 Power

Wire AC mains power to the power supply board, which is mounted vertically on the left hand side of the analyzer enclosure. The power connector is at the top of the board. Unplug the connector from the board and wire the power cable to it. Lead connections are marked on the connector. (L is live or hot; N is neutral, the ground connection has the standard symbol.)

AC power wiring should be 14 gauge or greater. Run the power wiring through the conduit opening nearest the power terminal. Provide a switch or breaker to disconnect the analyzer from the main power supply. Install the switch or breaker near the analyzer and label it as the disconnecting device for the analyzer.

3.1.2 Analog output wiring

Two analog current outputs are located on the main circuit board, which is attached to the inside of the enclosure door. Figure 3-1 shows the location of the terminals. The connectors can be detached for wiring. TB-1 is output 1. TB-2 is output 2. Polarity is marked on the circuit board.

For best EMI/RFI protection, use shielded output signal cable enclosed in earth-grounded metal conduit.

Keep output signal wiring separate from power wiring. Do not run signal and power or relay wiring in the same conduit or close together in a cable tray.

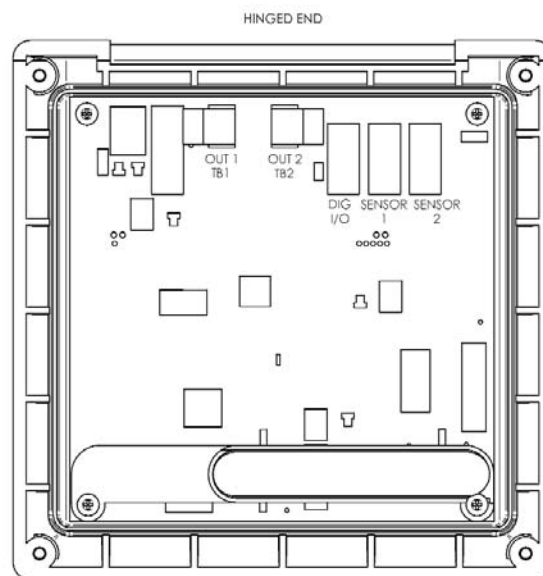
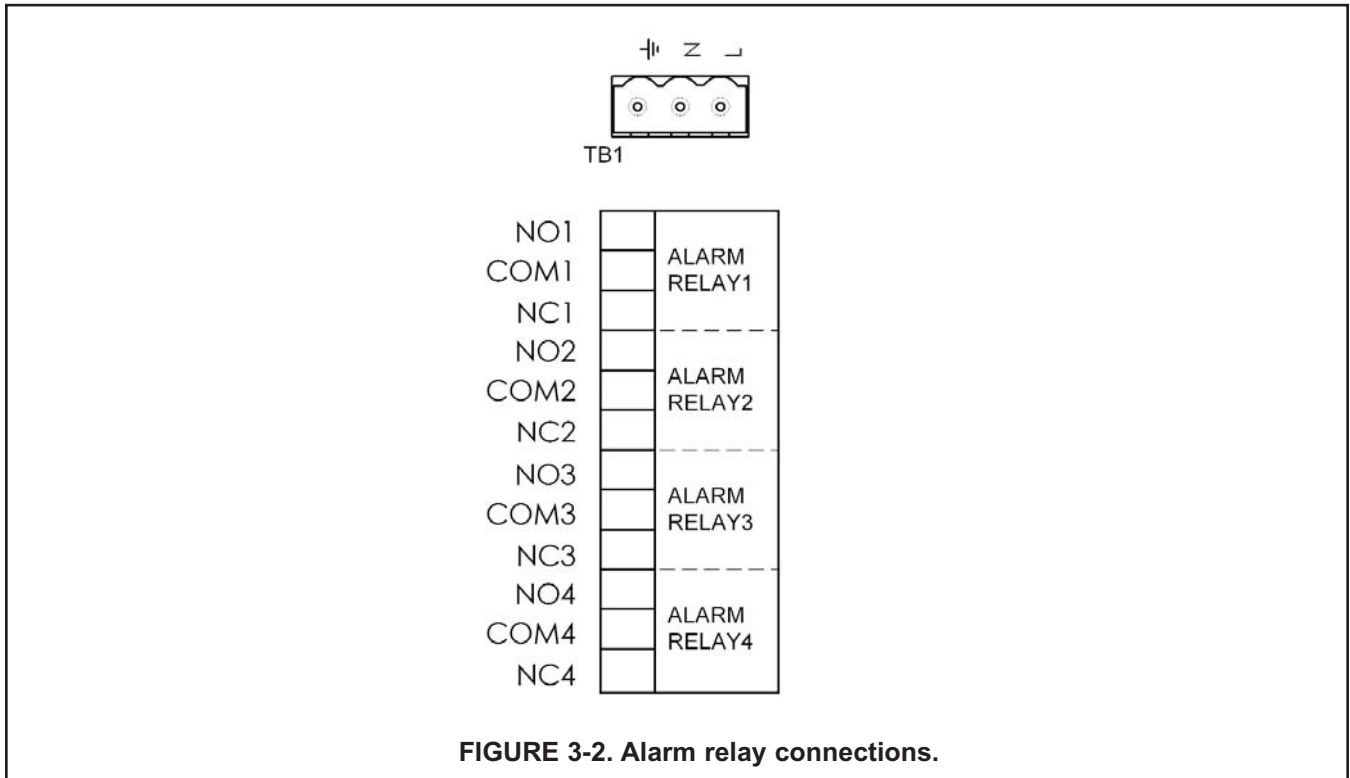

FIGURE 3-1. Analog output connections. The analog outputs are on the main board near the hinged end of the enclosure door.

3.1.3 Alarm wiring.

The alarm relay terminal strip is located just below the power connector on the power supply board. See Figure 3-2.

Keep alarm relay wiring separate from signal wiring. Do not run signal and power or relay wiring in the same conduit or close together in a cable tray.



3.2 SENSOR WIRING

The Model MCL is provided with sensor cables pre-wired to the analyzer. If it is necessary to replace the sensor cable, refer to the instructions below.

1. Shut off power to the analyzer.
2. Loosen the four screws holding the front panel in place and let it drop down.
3. Locate the signal board.

Slot 1 (left)	Slot 2 (center)
communication	input 1 (chlorine)

4. Loosen the gland fitting and carefully push the sensor cable up through the fitting as you pull the board forward to gain access to the wires and terminal screws. Disconnect the wires and remove the cable.
5. Insert the new cable through the gland and pull the cable through the cable slot.
6. Wire the sensor to the signal board. See Figure 3-3.
7. Once the cable has been connected to the board, slide the board fully into the enclosure while taking up the excess cable through the cable gland. Tighten the gland nut to secure the cable and ensure a sealed enclosure.

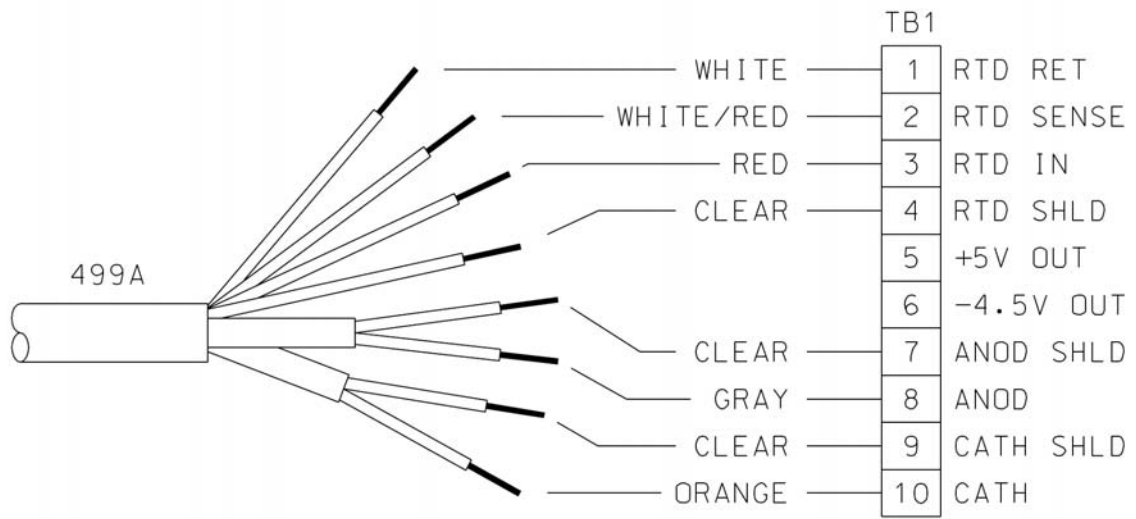

Figure 3-3. Wiring Sensor with Optimum EMI/RFI or Variopol Cable to Model 1056 Analyzer

SECTION 4.0 DISPLAY AND OPERATION

4.1. DISPLAY

The analyzer has a four line display. See Figure 4-1. The display can be customized to meet user requirements. Refer to section 4.6.

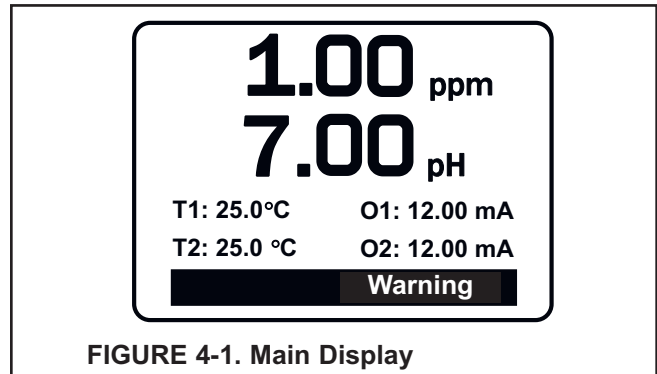

FIGURE 4-1. Main Display

When the analyzer is being programmed or calibrated, the display changes to a screen similar to the one shown in Figure 4-2. The live readings appear in small font at the top of the screen. The rest of the display shows programming and calibration information. Programming items appear in lists. The screen can show only four items at a time, and the arrow bar at the right of the screen indicates whether there are additional items in the list. See Figure 4.3 for an explanation of the arrow bar.

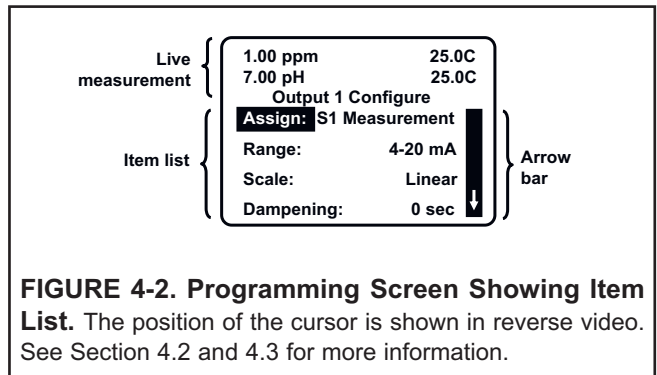

FIGURE 4-2. Programming Screen Showing Item List. The position of the cursor is shown in reverse video. See Section 4.2 and 4.3 for more information.

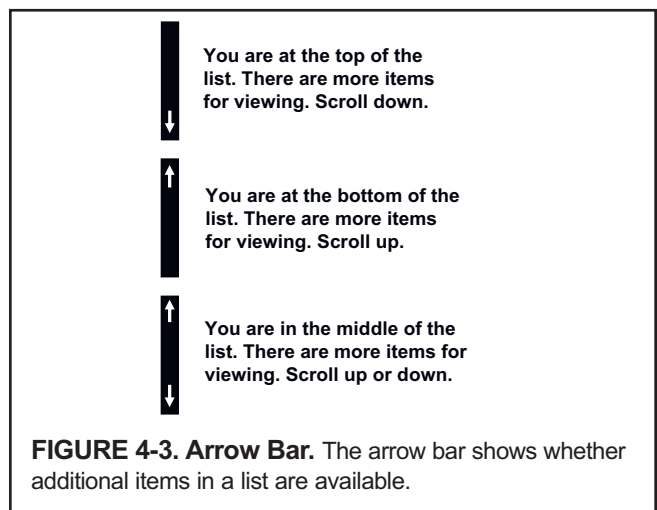
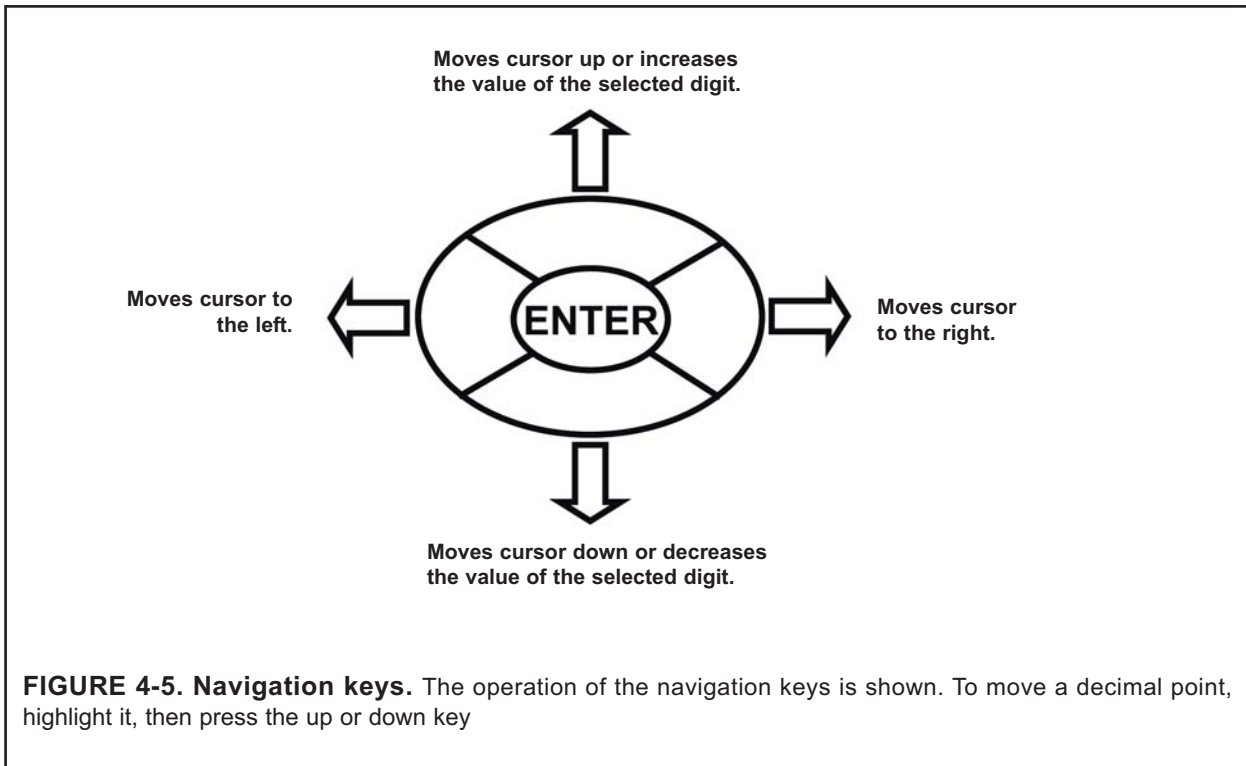
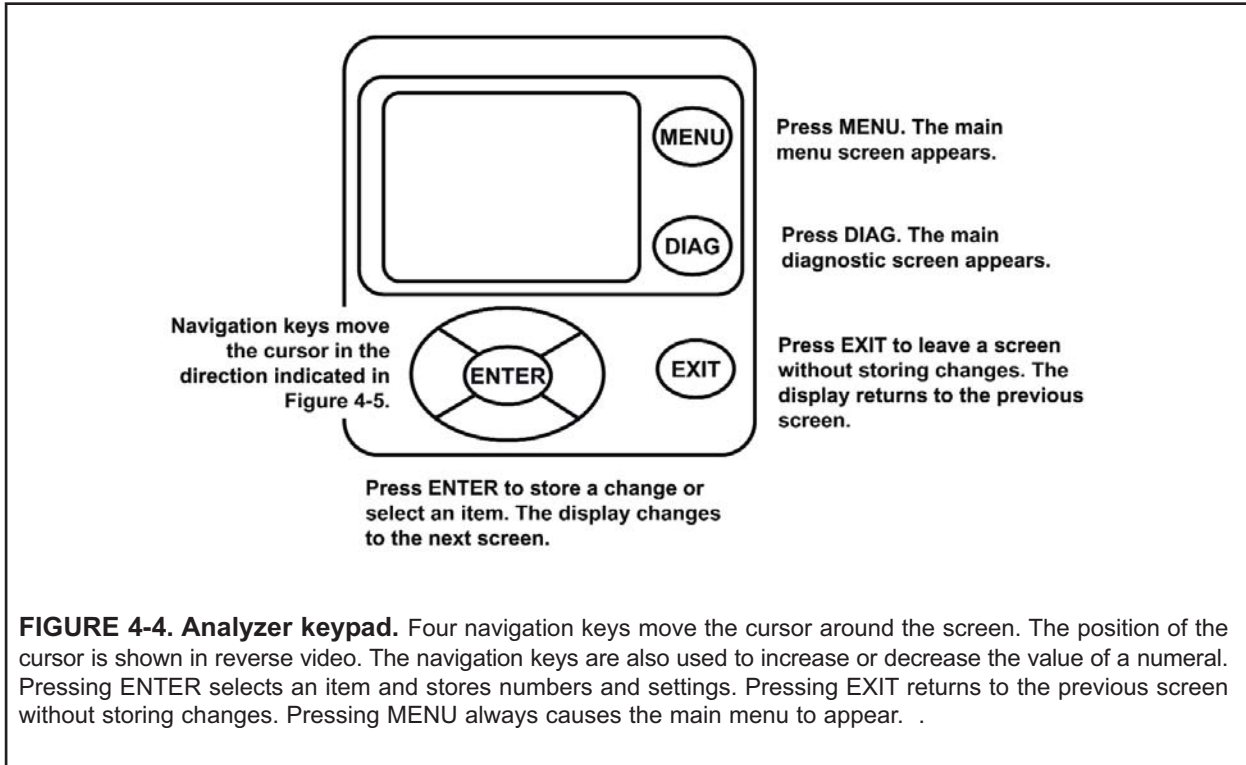

FIGURE 4-3. Arrow Bar. The arrow bar shows whether additional items in a list are available.

4.2 KEYPAD

Local communication with the analyzer is through the membrane keypad. Figures 4-4 and 4-5 explain the operation of the keys.



4.3 PROGRAMMING THE ANALYZER—TUTORIAL

Setting up and calibrating the analyzer is easy. The following tutorial describes how to move around in the programming menus. For practice, the tutorial also describes how to assign ppm monochloramine values to the 4 and 20 mA analog outputs.

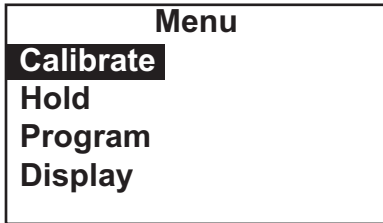

1. Press MENU. The main menu screen appears. There are four items in the main menu. **Calibrate** is in reverse video, meaning that the cursor is on Calibrate.

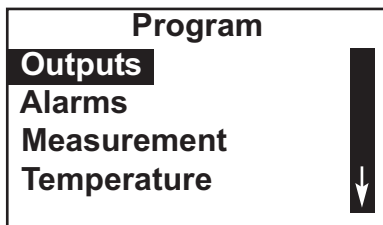

2. To assign values to the analog outputs, the **Program** sub-menu must be open. Use the down navigation key to move the cursor to **Program**. Press ENTER.

3. The Program menu appears. There are six items in the Program menu. The screen displays four items at a time. The downward pointing arrow on the right of the screen shows there are more items available in the menu. To view the other items, use the down key to scroll to the last item shown and continue scrolling down. When you have reached the bottom, the arrow will point up. Move the cursor back to **Outputs** and press ENTER.

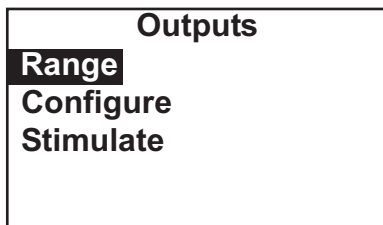

4. The screen at left appears. The cursor is on **Range**. **Output Range** is used to assign values to the low and high current outputs. Press ENTER.

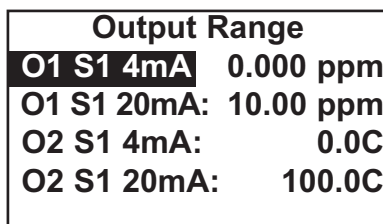

5. The screen at left appears. The screen shows the present values assigned to output 1 (**O1**) and output 2 (**O2**). The screen also shows which sensors the outputs are assigned to. **S1** is sensor 1. The assignments shown are the defaults for the MCL-220. Outputs are freely assignable under the configure menu.

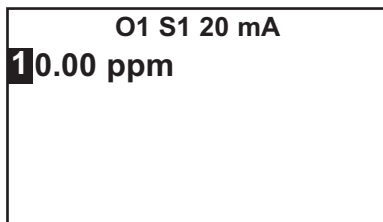

6. For practice, change the 20 mA setting for output 1 to 8.5 ppm.

- Move the cursor to the **O1 S1 20 mA: 10.00** line and press ENTER.
- The screen at left appears.
- Use the navigation keys to change 10.00 to 8.5 ppm. Use the left and right keys to move from digit to digit. Use the up and down keys to increase or decrease the numeral.
- To move the decimal point, press the left or right navigation key until the decimal point is highlighted. Press the up key to move the decimal point to the right. Press the down key to move to the left.
- Press ENTER to store the setting.

Output Range	
O1 S1 4mA:	0.000 ppm
O1 S1 20mA:	08.50 ppm
O2 S1 4mA:	0.0C
O2 S1 20mA:	100.0C

7. The display returns to the summary screen at left. Note that the 20 mA setting for output1 has changed to 8.5 ppm.

8. To return to the main menu, press MENU. To return to the main display, press MENU then EXIT.

4.4 SECURITY

4.4.1 How the Security Code Works

Security codes prevent accidental or unwanted changes to program settings or calibrations. There are three levels of security.

- a. A user can view the default display and diagnostic screens only.
- b. A user has access to the calibration and hold menus only.
- c. A user has access to all menus.

Security Code
000

1. If a security code has been programmed, pressing MENU causes the security screen to appear.

2. Enter the three-digit security code.

3. If the entry is correct, the main MENU screen appears. The user has access to the sub-menus the code entitles him to.

4. If the entry is wrong, the invalid code screen appears.

4.4.2 Assigning Security Codes.

See Section 5.7.

4.4.3 Bypassing Security Codes

Call the factory.

4.5 USING HOLD

4.5.1 Purpose

To prevent unwanted alarms and improper operation of control systems or dosing pumps, place the alarms and outputs assigned to the sensor in hold before removing it for maintenance. Hold is also useful if calibration will cause an out of limits condition. During hold, outputs assigned to the sensor remain at the last value, and alarms assigned to the sensor remain in their present state.

Once in hold, the sensor remains in hold until hold is turned off. However, if power is lost then restored, hold will automatically be turned off.

4.5.2 Using the Hold Function.

1. Press MENU. The main menu screen appears. Move the cursor to **Program**.

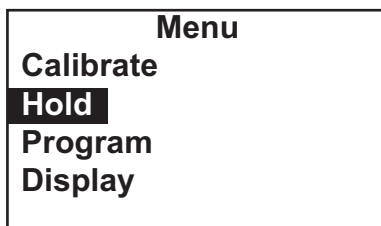

2. Choose HOLD.

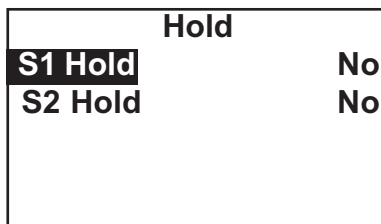

3. The screen shows the current hold status for each sensor. Select the sensor to be put in hold. Press ENTER.

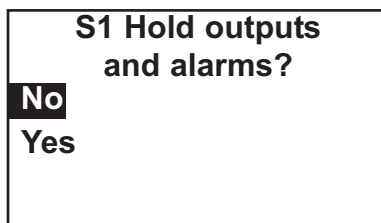

4. To put the sensor in hold, choose **Yes**. To take the sensor out of hold, choose **No**.

Once in hold, the sensor remains in hold until hold is turned off. However, if power is lost then restored, hold will automatically be turned off.

4.6 CONFIGURING THE MAIN DISPLAY

The main display can be configured to meet user requirements.

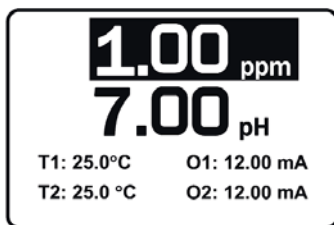
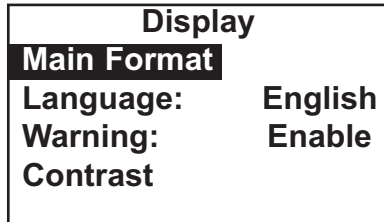

1. Press MENU. The main menu screen appears. Move the cursor to **Display** and press ENTER.
2. The screen shows the present configuration. There are four items: **Main Format, Language, Warning, and Contrast.**

To make a change, move the cursor to the desired line and press ENTER. A screen appears in which the present setting can be edited. Press ENTER to store the setting.

3. **Main Format** lets you configure the second line in the main display as well as the four smaller items at the bottom of the display. Move the cursor to the desired place in the screen and press ENTER. Scroll through the list of items and select the parameter you wish displayed. Once you are done making changes, press EXIT twice to return to the display menu. Press MENU then EXIT to return to the main display.

The following abbreviations are used in the quadrant display.

O	output
T	temperature (live)
Tm	temperature (manual)
M	measurement

4. Choose **Language** to change the language used in the display.
5. Choose **Warning** to disable or enable warning messages.
6. Choose **Contrast** to change the display contrast. To change the contrast, choose either lighter or darker and press ENTER. Every time you press ENTER the display will become lighter or darker.

SECTION 5.0

PROGRAMMING THE ANALYZER

5.1 GENERAL

This section describes how to make the following program settings using the local keypad.

- a. Configure and assign values to the analog current outputs.
- b. Configure and assign values to the alarm relays.
- c. Choose the type of chlorine measurement being made. This step is necessary because the analyzer used with the MCL can measure forms of chlorine other than monochloramine.
- d. Choose temperature units and automatic or manual temperature correction for chlorine and pH (if a pH sensor is installed).
- e. Set two levels of security codes.
- f. Reset the analyzer to factory default settings.

5.2 DEFAULT SETTINGS

The analyzer leaves the factory with the default settings shown in Table 5.1. The settings can be changed by the user to any value shown in the column labeled CHOICES.

TABLE 5-1. DEFAULT SETTINGS

ITEM	CHOICES	DEFAULT
Sensor assignment		
Sensor 1	monochloramine	monochloramine
Outputs		
1. Assignments		
a. output 1	monochloramine	monochloramine
b. output 2	temperature	temperature
2. Range		
	0-20 or 4-20 mA	4 – 20 mA
3. 0 or 4 mA setting		
a. chlorine	-9999 to +9999	0
b. temperature	-999.9 to +999.9	0
4. 20 mA setting		
a. chlorine	-9999 to +9999	10
b. temperature	-999.9 to +999.9	0
5. Fault current (fixed)		
	0.00 to 22.00 mA	22.00 mA
6. Dampening		
	0 to 999 sec	0 sec
7. Simulate		
	0.00 to 22.00 mA	12.00 mA
Alarms		
1. Logic		
	high or low	AL1 low, AL2,3,4 high
2. Assignments		
a. AL1 and AL2	monochloramine, temperature, fault, interval timer	monochloramine (sensor 1)
b. AL3 and AL4	monochloramine, temperature, fault, interval timer	temperature (sensor 1)
3. Deadband		
	0 to 9999	0
4. Interval timer settings		
a. interval time	0.0 to 999.9 hr	24.0 hr
b. on time	0 to 999 sec	10 sec
c. recovery time	0 to 999 sec	60 sec

TABLE 5-1. DEFAULT SETTINGS (continued)

ITEM	CHOICES	DEFAULT
Measurement		
1. Monochloramine (sensor 1)		
a. units	ppm or mg/L	ppm
b. resolution	0.01 or 0.001	0.001
c. input filter	0 to 999 sec	5 sec
Temperature related settings		
1. Units	°C or °F	°C
2. Temperature compensation	automatic or manual	automatic
Security Code		
1. Calibrate/Hold	000 to 999	000
2. Program/Display	000 to 999	000
Calibration–Analog Outputs		
1. 4 mA	0.000 to 22.000 mA	4.000 mA
2. 20 mA	0.000 to 22.000 mA	20.000 mA

5.3 CONFIGURING, RANGING, AND SIMULATING OUTPUTS.

5.3.1 Purpose

This section describes how to configure, range, and simulate the two analog current outputs. **CONFIGURE THE OUTPUTS FIRST.**

1. Configuring an output means...
 - a. Assigning a sensor and measurement (monochloramine or temperature) to an output.
 - b. Selecting a 4-20 mA or 0-20 mA output.
 - c. Choosing a linear or logarithmic output.
 - d. Set the amount of dampening on the analog outputs.
 - e. Selecting the value the output current goes to if the analyzer detects a fault.
2. Ranging the outputs means assigning values to the low (0 or 4 mA) and high (20 mA) outputs.
3. Simulating an output means making the analyzer generate an output current equal to the value entered by the user.

5.3.2 Definitions

1. **ANALOG CURRENT OUTPUT.** The analyzer provides either a continuous 4-20 mA or 0-20 mA output signal proportional to monochloramine or temperature.
2. **ASSIGNING AN OUTPUT.** The outputs are freely assignable. Outputs can be assigned to either monochloramine or temperature.
3. **LINEAR OUTPUT.** Linear output means the current is directly proportional to the value of the variable assigned to the output (monochloramine or temperature).
4. **LOGARITHMIC OUTPUT.** Logarithmic output means the current is directly proportional to the common logarithm of the variable assigned to the output (monochloramine or temperature).
5. **DAMPENING.** Output dampening smoothes out noisy readings. It also increases response time. The time selected for output dampening is the time to reach 63% of the final reading following a step change. Output dampening does not affect the response time of the display.
6. **FAULT.** The analyzer continuously monitors itself and the sensor for faults. If the analyzer detects a fault, a fault message appears in the main display. At the same time the output current goes to the value programmed in this section. There are two output fault modes: fixed and live. Fixed means the selected output goes the previously programmed value (between 0.00 and 22.00 mA) when a fault occurs. Live means the selected output is unaffected when a fault occurs.
7. **RANGING AN OUTPUT.** The outputs are fully rangeable, including negative numbers. If the output is logarithmic, assigned values must be positive.

5.3.3. Procedure – Configure Outputs.

1. Press MENU. The main menu screen appears. Move the cursor to Program and press ENTER.

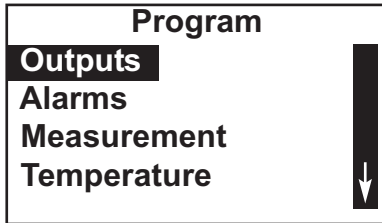

2. The cursor will be on **Outputs**. Press ENTER.

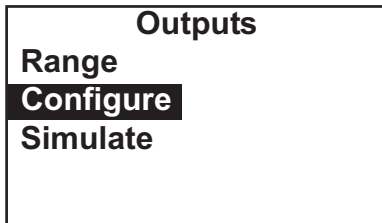

3. Choose **Configure**.

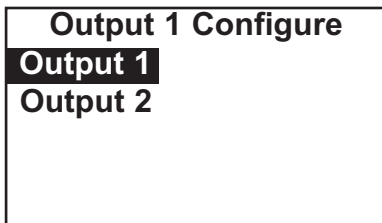

4. Choose **Output 1** or **Output 2**.

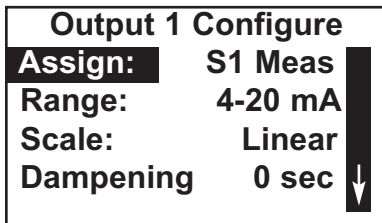

5. The screen shows the present configuration. There are six items: **Assign** (S1 is sensor 1), **Range**, **Scale**, **Dampening**, **Fault Mode**, and **Fault Value**. To display the fifth and sixth items, scroll to the bottom of the screen and continue scrolling.

To make a change, move the cursor to the desired line and press ENTER. A screen will appear in which the present setting can be edited. Press ENTER to store the setting.

For an explanation of terms, see sections 5.3.1 and 5.3.2.

6. To return to the main display, press MENU then EXIT.

5.3.4. Procedure – Ranging Outputs.

1. Press MENU. The main menu screen appears. Move the cursor to **Program** and press ENTER.

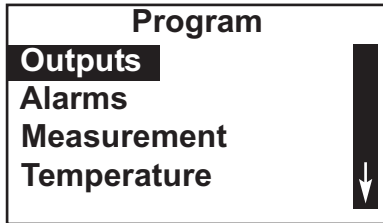

2. The cursor will be on **Outputs**. Press ENTER.

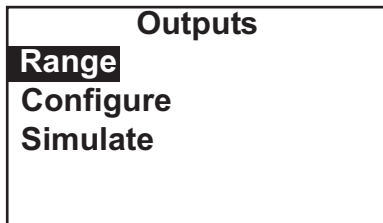

3. Choose **Range**.

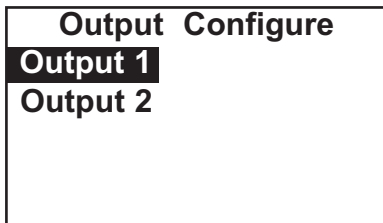

4. Choose **Output 1** or **Output 2**.

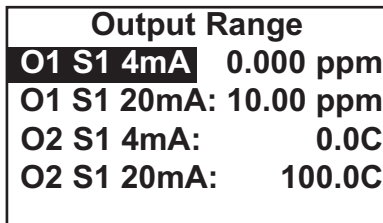

5. The screen shows the present settings for the outputs. **O1** is output 1, **O2** is output 2, and **S1** is sensor 1.

To make a change, move the cursor to the desired line and press ENTER. A screen will appear in which the present setting can be edited. Press ENTER to store the setting.

For an explanation of terms, see sections 5.3.1 and 5.3.2.

6. To return to the main display, press MENU then EXIT.

5.3.5 Procedure – Simulating Outputs

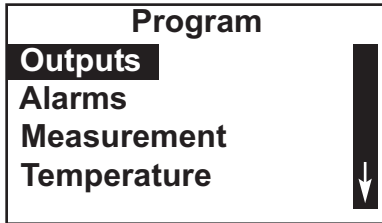

1. Press MENU. The main menu screen appears. Move the cursor to Program and press ENTER.
2. The cursor will be on **Outputs**. Press ENTER.

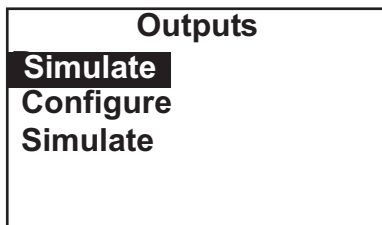

3. Choose **Simulate**.

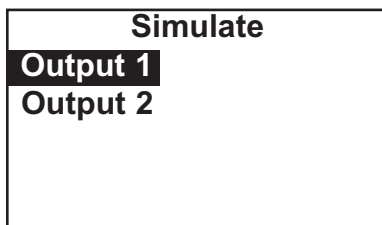

4. Choose **Output 1** or **Output 2**.

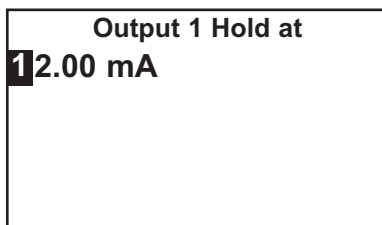

5. Enter the desired simulated output current. To end the simulated current, press MENU or EXIT.

5.4 CONFIGURING ALARMS AND ASSIGNING SETPOINTS.

5.4.1 Purpose

The Model MCL-220 analyzer has an **optional** alarm relay board. This section describes how to configure and assign setpoints to the alarm relays, simulate alarm action, and synchronize interval timers. CONFIGURE THE ALARMS FIRST.

1. Configuring an alarm means...
 - a. Assigning a sensor and measurement (monochloramine or temperature) to an alarm. An alarm relay can also be used as a timer.
 - b. Selecting high or low logic.
 - c. Choosing a deadband.
 - d. Setting the interval timer parameters.
2. Simulating an alarm means making the analyzer energize or de-energize an alarm relay.

5.4.2 Definitions

1. **ASSIGNING ALARMS.** There are four alarms relays. The relays are freely assignable to either monochloramine or temperature. Alarm relays can also be assigned to operate as interval timers or as fault alarms. A fault alarm activates when the analyzer detects a fault in either itself or the sensor.
2. **FAULT ALARM.** A fault condition exists when the analyzer detects a problem with the sensor or with the analyzer itself that is likely to cause seriously erroneous readings. If an alarm was programmed as a fault alarm, the alarm will activate. At the same time a fault message will appear in the main display.
3. **ALARM LOGIC, SETPOINTS, AND DEADBANDS.** See Figures 5-1 and 5-2.
4. **INTERVAL TIMER.** Any alarm relay can be used as an interval timer. Figure 5-3 shows how the timer operates. While the interval timer is operating, the main display, analog output, and assigned alarms for the sensor can be put on hold. During hold, the main display remains at the last value.
5. **SYNCHRONIZE TIMER.** If two or more relays are being used as interval timers, choosing synchronize timers will cause each timer to start one minute later than the preceding timer.

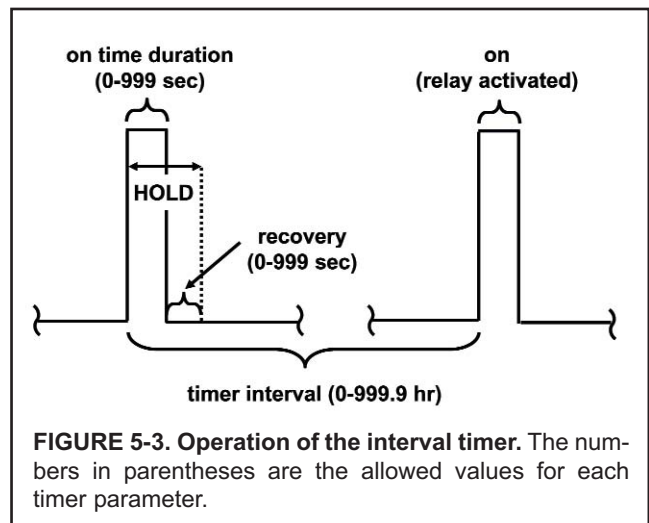
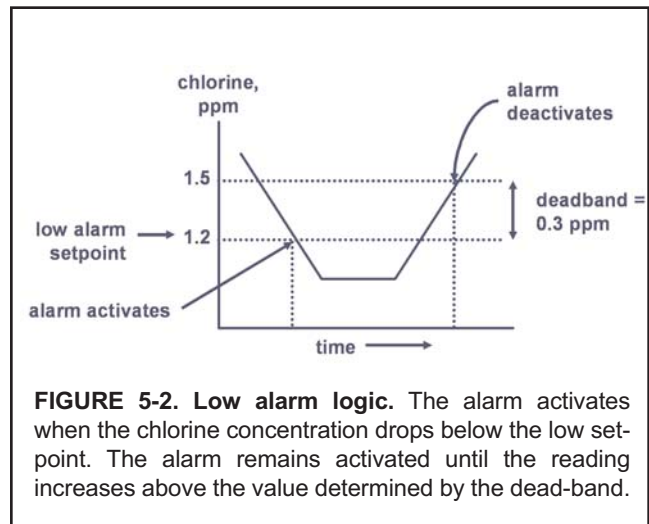
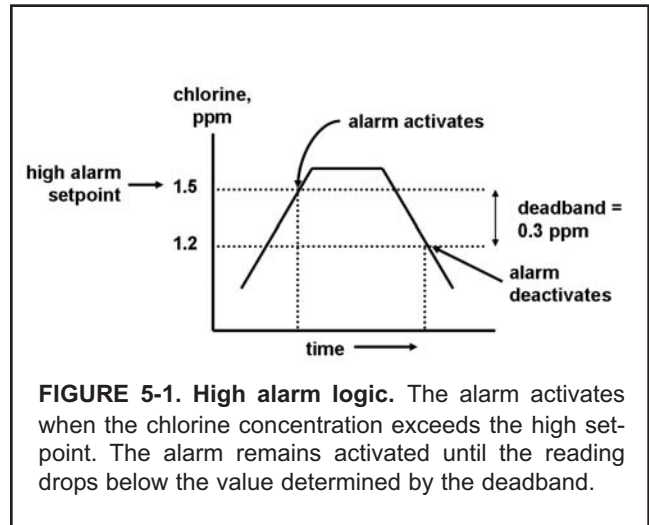

5.4.3 Procedure – Configuring Alarms and Assigning Setpoints

1. Press MENU. The main menu screen appears. Move the cursor to **Program** and press ENTER.

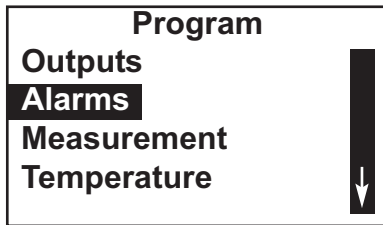

2. Choose **Alarms**.

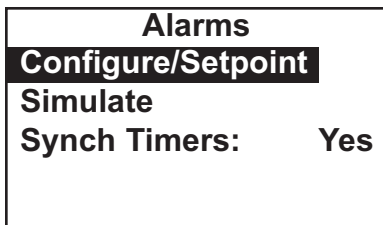

3. Choose **Configure/Setpoint**.

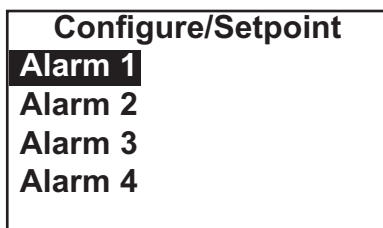

4. Choose **Alarm 1, Alarm 2, Alarm 3, or Alarm 4**.

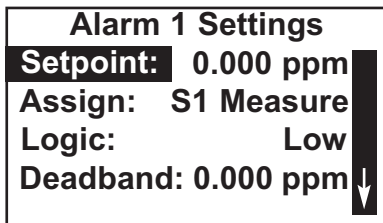

5. The screen summarizes the present configuration and setpoints. There are nine items: **Setpoint, Assign (S1 is sensor 1), Logic, Deadband, Interval time, On time, Recover time, and Hold while active**. The last four items describe the operation of the timer. Only four items are shown at a time. To view the remaining items, scroll to the bottom of the screen and continue scrolling.

To make a change, move the cursor to the desired line and press ENTER. A screen will appear in which the present setting can be edited. Press ENTER to store the setting.

For an explanation of terms, see sections 5.4.1 and 5.4.2.

6. To return to the main display, press MENU then EXIT.

5.4.4 Procedure – Simulating Alarms

1. Press MENU. The main menu screen appears. Move the cursor to **Program** and press ENTER.

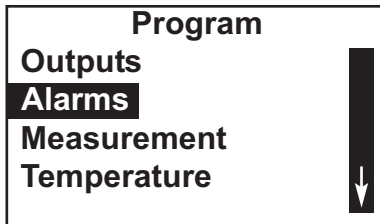

2. Choose **Alarms**.



3. Choose **Simulate**.

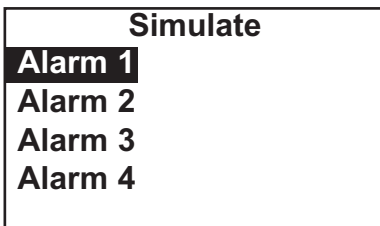

4. Choose **Alarm 1**, **Alarm 2**, **Alarm 3**, or **Alarm 4**.

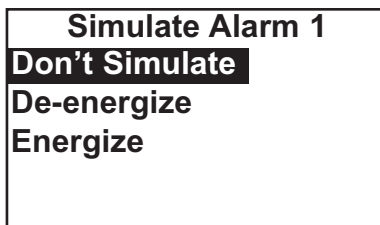

5. Choose **Don't simulate**, **De-energize**, or **Energize**. Press MENU or EXIT to end simulation.

5.4.4 Procedure – Synchronizing Timers

1. **Synch Timers** is available only if two or more alarm relays have been configured as interval timers.
2. Press MENU. The main menu screen appears. Move the cursor to Program and press ENTER.
3. Choose **Alarms**.

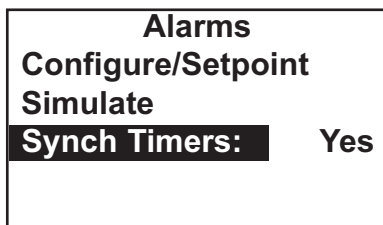
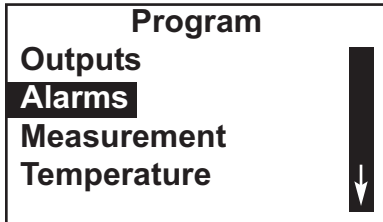

4. The summary display shows the current **Synch Timers** setting (**Yes** or **No**).
To make a change, choose **Synch Timers** and press ENTER. A screen will appear in which the present setting can be edited. Press ENTER to store the setting.
For an explanation of terms, see sections 5.4.1 and 5.4.2.

5. To return to the main display, press MENU then EXIT.

5.5 CONFIGURING THE MEASUREMENT.

5.5.1 Purpose

This section describes how to do the following:

1. Program the analyzer to measure monochloramine using the 499ACL-03 sensor. This step is necessary because the analyzer can be used with other sensors to measure other chlorine oxidants.
2. Set the level of electronic filtering of the sensor current.

5.5.2 Definitions - Chlorine

1. CHLORINE OXIDANTS. Although the MCL is used to measure monochloramine only, the analyzer used in the MCL can be used to measure other chlorine oxidants, for example free and total chlorine.
2. FILTER. The analyzer applies a software filter to the raw sensor current. The filter reduces noisy readings, but increases the response time. Only the filter time can be changed. The filter threshold cannot be changed.
3. RESOLUTION. If the chlorine concentration is less than 1.00 ppm (mg/L), the display resolution can be set to 0.XX or 0.XXX.

5.5.3 Procedure – Configuring the Measurement

1. Press MENU. The main menu screen appears. Move the cursor to Program and press ENTER.

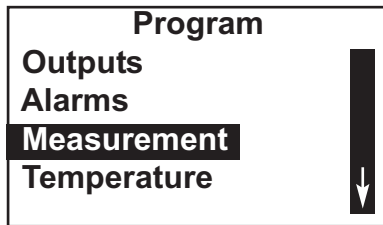

2. Choose **Measurement**.

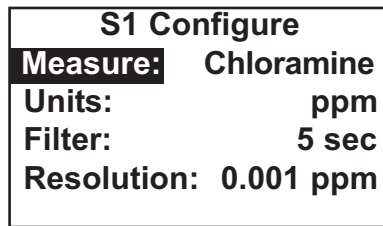

3. The screen summarizes the present configuration for sensor 1 (monochloramine). There are four items: **Measure**, **Units**, **Filter**, and **Resolution**

To make a change, move the cursor to the desired line and press ENTER. A screen will appear in which the present setting can be edited. To store the setting press ENTER.

- a. For **Measurement** choose **Chloramine**.
 - b. Leave **Filter** at the default value unless readings are noisy.
4. To return to the main display, press MENU then EXIT.

5.6 CONFIGURING TEMPERATURE RELATED SETTINGS

5.6.1 Purpose

This section describes how to do the following:

1. Choose temperature units.
2. Choose automatic or manual temperature correction for membrane permeability.
3. Enter a temperature for manual temperature compensation.

5.6.2 Definitions

1. **AUTOMATIC TEMPERATURE CORRECTION.** The monochloramine sensor is a membrane-covered amperometric sensor. It produces a current directly proportional to the rate of diffusion of monochloramine through the membrane. The diffusion rate, in turn, depends on the concentration of monochloramine in the sample and the membrane permeability. Membrane permeability is a function of temperature. As temperature increases, permeability increases. Thus, an increase in temperature will cause the sensor current and the analyzer reading to increase even though the concentration of monochloramine remained constant. In automatic temperature correction, the analyzer uses the temperature measured by the sensor to continuously correct for changes in membrane permeability.
2. **MANUAL TEMPERATURE CORRECTION.** In manual temperature correction, the analyzer uses the temperature entered by the user for correction. It does not use the actual process temperature. Do NOT use manual temperature correction unless the measurement and calibration temperatures differ by no more than about 2°C. Manual temperature correction is useful if the sensor temperature element has failed and a replacement sensor is not available.

5.6.3 Procedure – Configuring Temperature Related Settings

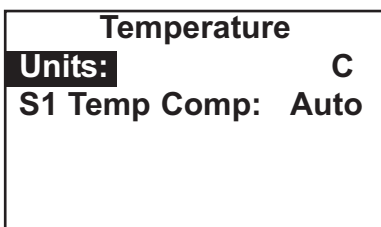
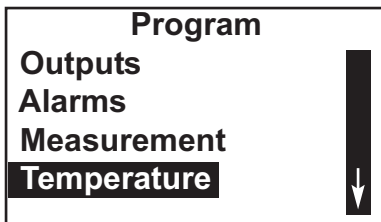

1. Press MENU. The main menu screen appears. Move the cursor to Program and press ENTER.
2. Choose **Temperature**.
3. The screen summarizes the present sensor configuration. There will be between two and three items. **Units** and **S1 Temp Comp**, always appear. If manual temperature compensation was selected, the manual temperature value entered for sensor (**S1 Manual**) will also appear.

To make a change, move the cursor to the desired line and press ENTER. A screen will appear in which the present setting can be edited. To store a setting, press ENTER.
4. For an explanation of terms, see section 5.6.2.
5. To return to the main display, press MENU then EXIT.

5.7 CONFIGURING SECURITY SETTINGS

5.7.1 Purpose

This section describes how to set security codes. There are three levels of security.

- a. A user can view the default display and diagnostic screens only.
- b. A user has access to the calibration and hold menus only.
- c. A user has access to all menus.

The security code is a three digit number. The table shows what happens when different security codes (XXX and YYY) are assigned to **Calibration/Hold** and **All**. 000 means no security.

Calibration/Hold	All	What happens...
000	XXX	User enters XXX and has access to all menus.
XXX	YYY	User enters XXX and has access to Calibration and Hold menus only. User enters YYY and has access to all menus.
XXX	000	User needs no security code to have access to all menus.
000	000	User needs no security code to have access to all menus.

5.7.2 Procedure – Configuring Security Settings

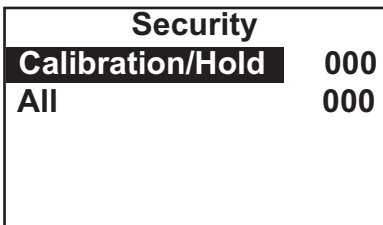
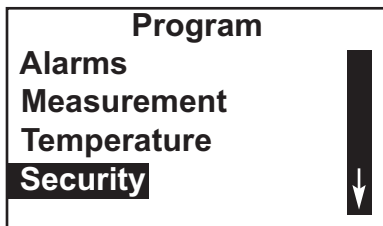

1. Press MENU. The main menu screen appears. Move the cursor to Program and press ENTER.
2. Scroll to the bottom of the screen and continue scrolling until **Security** is highlighted. Press ENTER.
3. The screen shows the existing security codes. To make a change, move the cursor to the desired line and press ENTER. A screen will appear in which the present setting can be edited. Press ENTER to store the change. The security code takes effect two minutes after pressing ENTER.
4. To return to the main display, press MENU then EXIT.

5.8 RESETTING THE ANALYZER

5.8.1 Purpose

This section describes how to clear user-entered values and restore default settings. There are three resets:

1. Resetting to factory default values clears **ALL** user-entered settings, including sensor and analog output calibration, and returns **ALL** settings and calibration values to the factory defaults.
2. Resetting a sensor calibration to the default values clears user-entered calibration data for the selected sensor but leaves all other user-entered data unaffected.
3. Resetting the analog output calibration clears only the user-entered analog output calibration. It leaves all other user-entered settings unchanged.

5.8.2 Procedure – Resetting the Analyzer

1. Press MENU. The main menu screen appears. Move the cursor to Program and press ENTER.

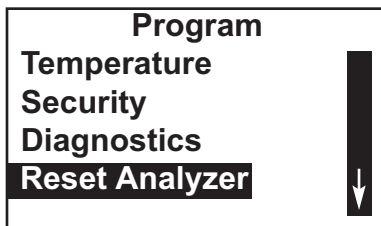

2. Scroll to the bottom of the screen and continue scrolling until **Reset Analyzer** is highlighted. Press ENTER.



3. Choose whether to reset all user-entered values (**Factory Defaults**), sensor calibration (**Sensor Cal Only**), or output calibration (**Output Cal Only**). If you choose **Sensor Cal Only** or **Output Cal Only** a second screen appears in which you can select which sensor or output calibration to reset.

4. To return to the main display, press MENU then EXIT.

SECTION 6.0 CALIBRATION

6.1 INTRODUCTION

The calibrate menu allows the user to do the following:

1. Calibrate the temperature sensing element in the monochloramine sensor.
2. Calibrate the monochloramine sensor.
3. Calibrate the analog outputs.

6.2 CALIBRATING TEMPERATURE

6.2.1 Purpose

The monochloramine sensor is a membrane-covered amperometric sensor. As the sensor operates, monochloramine diffuses through the membrane and is consumed at an electrode immediately behind the membrane. The reaction produces a current that depends on the rate at which the monochloramine diffuses through the membrane. The diffusion rate, in turn, depends on the concentration of monochloramine and how easily it passes through the membrane (the membrane permeability). Because membrane permeability is a function of temperature, the sensor current will change if the temperature changes. To account for changes in sensor current caused by temperature alone, the analyzer automatically applies a membrane permeability correction. The membrane permeability changes about 3%/°C at 25°C, so a 1°C error in temperature produces about a 3% error in the reading.

Without calibration the accuracy of the temperature measurement is about $\pm 0.4^\circ\text{C}$. Calibrate the sensor/analyzer unit if

1. $\pm 0.4^\circ\text{C}$ accuracy is not acceptable
2. the temperature measurement is suspected of being in error. Calibrate temperature by making the analyzer reading match the temperature measured with a **standard thermometer**.

6.2.2 Procedure

1. Remove the sensor from the flow cell. Place it in an insulated container of water along with a **calibrated thermometer**. Submerge at least the bottom two inches of the sensor.
2. Allow the sensor to reach thermal equilibrium. The time constant for the sensor is about 5 min., so it may take as long as 30 min for equilibration.

3. Press MENU. The main menu screen appears. The cursor will be on Calibrate. Press ENTER.

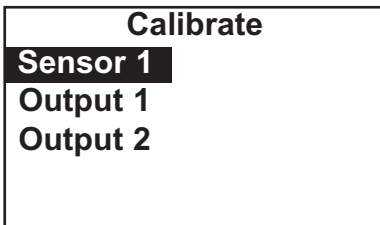

4. Choose the sensor you wish to calibrate. **Sensor 1** is the monochloramine sensor.

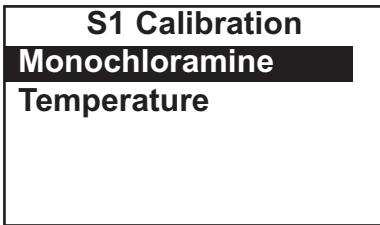

5. Choose **Temperature**.

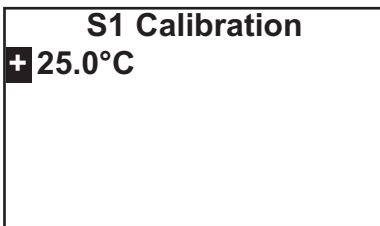

6. Change the display to match the temperature read from the calibrated thermometer. Press ENTER.

If the present temperature is more than 5°C different from the value entered, an error message appears. To force the analyzer to accept the calibration, choose **Yes**. To repeat the calibration, choose **No**. For troubleshooting assistance, see Section 8.6.

7. To return to the main display, press MENU then EXIT.

6.3 CALIBRATION — MONOCHLORAMINE

6.3.1 Purpose

As Figure 6-1 shows, a monochloramine sensor generates a current directly proportional to the concentration of monochloramine in the sample. Calibrating the sensor requires exposing it to a solution containing no monochloramine (zero standard) and to a solution containing a known amount of monochloramine (full-scale standard).

The zero standard is necessary because monochloramine sensors, even when no monochloramine is in the sample, generate a small current called the residual current or zero current. The analyzer compensates for the residual current by subtracting it from the measured current before converting the result to a monochloramine value. New sensors require zeroing before being placed in service, and sensors should be zeroed whenever the fill solution is replaced. Deionized water makes a good zero standard.

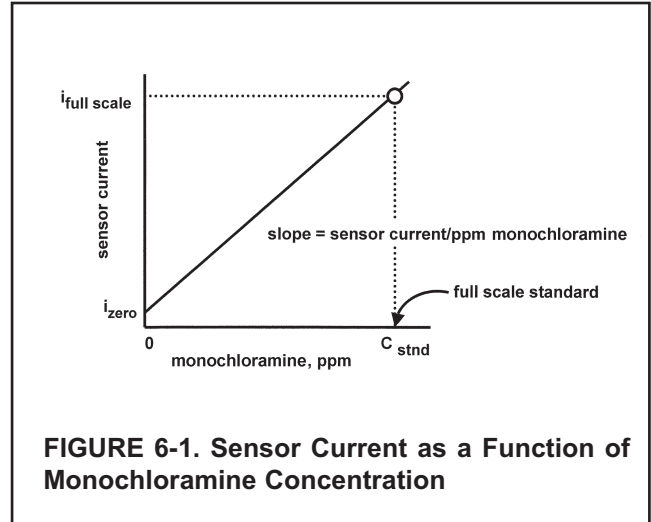

FIGURE 6-1. Sensor Current as a Function of Monochloramine Concentration

The purpose of the full-scale standard is to establish the slope of the calibration curve. Because stable monochloramine standards do not exist, **the sensor must be calibrated against a test run on a grab sample of the process liquid.** Several manufacturers offer portable test kits for this purpose. Observe the following precautions when taking and testing the grab sample.

- Take the grab sample from a point as close to the MCL as possible. Be sure that taking the sample does not alter the flow of the sample to the unit. It is best to install the sample tap just downstream from the tap for the MCL.
- Monochloramine solutions are moderately unstable. Run the test immediately after taking the sample. Try to calibrate the sensor when the monochloramine concentration is at the upper end of the normal operating range.

6.3.2 Procedure-Zeroing the Sensor

1. Remove the sensor from the flow cell and place it in the zero standard (deionized water). Be sure no air bubbles are trapped against the membrane. The sensor current will drop rapidly at first and then gradually reach a stable zero value. To monitor the sensor current, press the DIAG key. Choose **Sensor 1** (monochloramine). The input current is the first line in the display. Note the units: nA is nanoamps, uA is microamps. Typical zero current for a new sensor is between -10 and 15 nA.

A new sensor or a sensor in which the electrolyte solution has been replaced may require several hours (occasionally as long as overnight) to reach a minimum zero current. **DO NOT START THE ZERO ROUTINE UNTIL THE SENSOR HAS BEEN IN ZERO SOLUTION FOR AT LEAST TWO HOURS.**

2. Press MENU. The main menu screen appears. The cursor will be on **Calibrate**. Press ENTER.

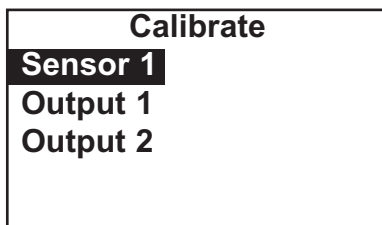

3. Choose **Sensor 1**.

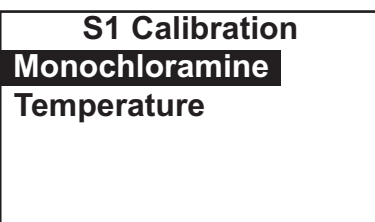

4. Choose **Monochloramine**.

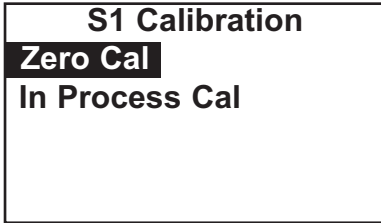

5. Choose **Zero Cal**. The analyzer will automatically start the zero calibration

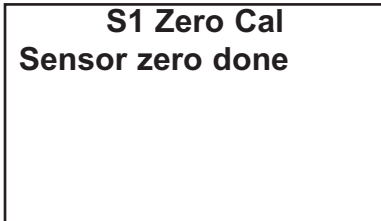

6. If the zero calibration was successful, the screen at left appears.

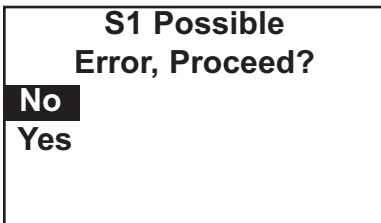

If the zero current is moderately larger than expected, an error message appears. To force the analyzer to accept the zero current, choose **Yes**. To repeat the calibration, choose **No**. For troubleshooting assistance, see Section 8.5.

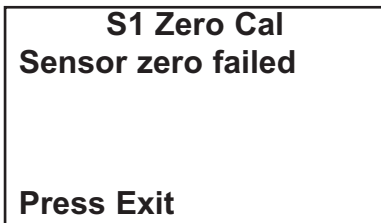

If the zero current is much larger than expected, the zero calibration failure screen appears. The analyzer will not update the zero current. For troubleshooting assistance, see Section 8.5.

7. To return to the main display, press MENU then EXIT.

6.3.3 Procedure-Calibrating the Sensor

1. Place the monochloramine sensor in the flow cell. Adjust the sample flow until water overflows the inside tube in the constant head flow controller.
2. Adjust the monochloramine concentration until it is near the upper end of the operating range. Wait until the analyzer reading is stable before starting the calibration.

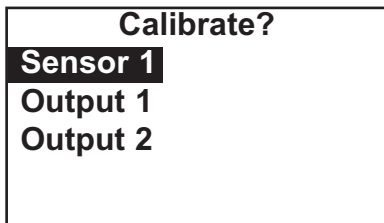

3. Press MENU. The main menu screen appears. The cursor will be on **Calibrate**. Press ENTER.

4. Choose **Sensor 1**.

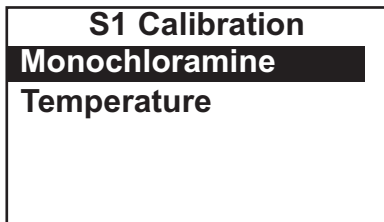

5. Choose **Monochloramine**.

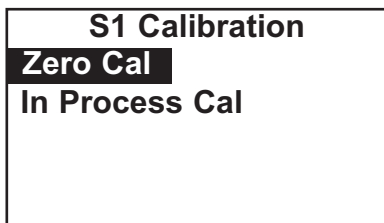

6. Choose **In Process Cal**

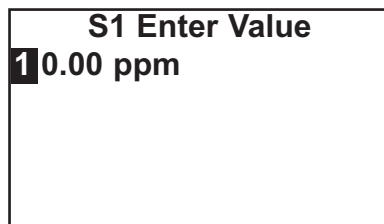

7. Follow the screen prompts: Once the reading is stable, press ENTER. Take the sample and press ENTER. At this point, the analyzer will store the present sensor current and temperature and use those values in the calibration.

Determine the free chlorine concentration in the sample and enter the value in the screen shown at left. See Section 6.3.1 for sampling and testing precautions.

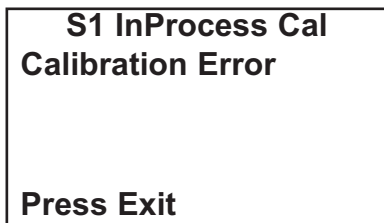

8. If the calibration is successful, the live reading will change to the value entered in step 7 and the display will return to the screen in step 6.

If the sensitivity is too far outside the range of expected values, the calibration error screen shown at left will appear. The analyzer will not update the calibration. For troubleshooting assistance, see Section 8.5.

9. To return to the main display, press MENU then EXIT.

6.4 CALIBRATION – Analog Outputs

6.4.1 Purpose

Although the analyzer analog outputs are calibrated at the factory, they can be trimmed in the field to match the reading from a standard milliammeter. Both the low (0 or 4 mA) and high (20 mA) outputs can be trimmed.

6.4.2 Procedure

1. Connect a calibrated milliammeter across the output you wish to calibrate. If a load is already connected to the output, disconnect the load. Do not put the milliammeter in parallel with the load.

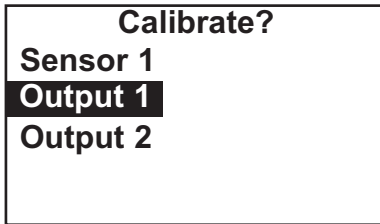

2. Press MENU. The main menu screen appears. The cursor will be on **Calibrate**. Press ENTER.
3. Choose the output you wish to calibrate.

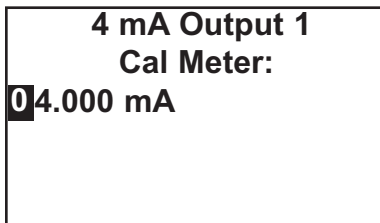

4. The analyzer will simulate the low output current. Change the value in the display to match the reading from the milliammeter.

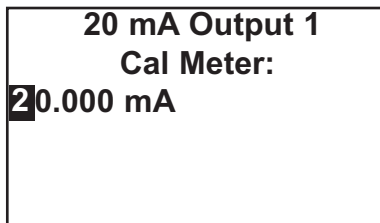

5. The analyzer will simulate the 20 mA output current. Change the value in the display to match the reading from the milliammeter.

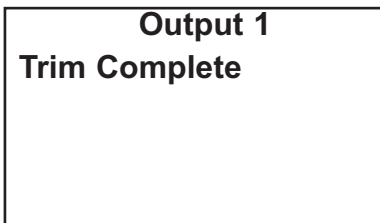

6. If the calibration was successful, the screen at left will appear.

7. If the user entered value is more than ± 1 mA different from the nominal value, a possible error screen will appear. To force the analyzer to accept the calibration, choose **Yes**.

8. To return to the main display, press MENU then EXIT.

SECTION 7.0 MAINTENANCE

7.1 ANALYZER

The analyzer used with the MCL needs little routine maintenance.

Clean the analyzer case and front panel by wiping with a clean soft cloth dampened with water ONLY. Do not use solvents, like alcohol, that might cause a buildup of static charge.

The sensor circuit board (PN 24203-01) is replaceable.

To replace the board

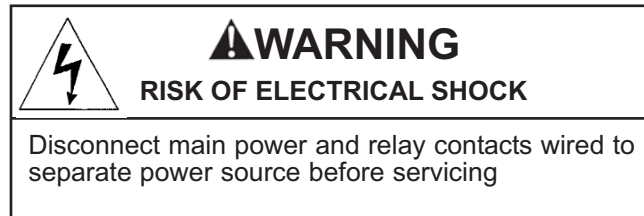

1. Turn off power to the analyzer.
2. Loosen the four screws holding the front panel in place and let the front panel drop down.
3. Loosen the gland fitting and carefully push the sensor cable up through the fitting as you pull out the circuit board.
4. Once you have access to the terminal strip, disconnect the sensor.
5. Unplug the sensor board from the main board. See Figure 3-2.
6. Slide the replacement board partially into the board slot. Plug the sensor board into the main board and reattach the sensor wires.
7. Carefully pull the sensor cable through the gland fitting as you push the sensor board back into the enclosure. Tighten the table glands.
8. Close the front panel.
9. Turn on power.

7.2 MONOCHLORAMINE SENSOR

7.2.1 General.

When used in clean water, the monochloramine sensor requires little maintenance. Generally, the sensor needs maintenance when the response becomes sluggish or noisy or when readings drift following calibration. For a sensor used in potable water, expect to clean the membrane every month and replace the membrane and electrolyte solution every two or three months. Actual cleaning and maintenance frequency can be determined only by experience.

7.2.2 Cleaning the membrane.

Keep the membrane clean and free from dirt and algae. Periodically inspect the membrane. If it appears fouled and sensor response is less than expected, clean the membrane by using a stream of water from a wash bottle.

NOTE

**Do not use a tissue to clean the sensor. Do not touch the membrane.
Doing so may damage the cathode, making the sensor unusable.**

7.2.3 Replacing the electrolyte solution and membrane.

CAUTION

Fill solution may cause irritation. May be harmful if swallowed. Read and follow manual.

1. Unscrew the membrane retainer and remove the membrane assembly and O-ring. See Figure 7-1.

NOTE

Do not touch the cathode. Doing so may damage the cathode, making the sensor unusable.

2. Hold the sensor over a container with the cathode pointing down.
3. Remove the fill plug and allow the electrolyte solution to drain out.
4. Wrap the plug with several turns of pipe tape and set aside.
5. Prepare a new membrane. Hold the membrane assembly with the cup formed by the membrane and membrane holder pointing up. Fill the cup with electrolyte solution.
6. Hold the sensor at about a 45-degree angle with the cathode end pointing up. Add electrolyte solution through the fill hole until the liquid overflows. Tap the sensor near the threads to release trapped air bubbles. Add more electrolyte solution if necessary.
7. Place the fill plug in the electrolyte port and begin screwing it in. After several threads have engaged, rotate the sensor so that the cathode is pointing up and continue tightening the fill plug. Do not overtighten.
8. Place a new O-ring in the groove around the cathode post. Cover the holes at the base of the cathode stem with several drops of electrolyte solution.
9. Cover the cathode with electrolyte solution, then place the membrane assembly over the cathode. Screw the membrane retainer in place.
10. Hold the sensor with the cathode end pointing down. Give the sensor several sharp shakes to dislodge air bubbles trapped behind the cathode.
11. The sensor may require several hours operating at the polarizing voltage to equilibrate after the electrolyte solution has been replaced.

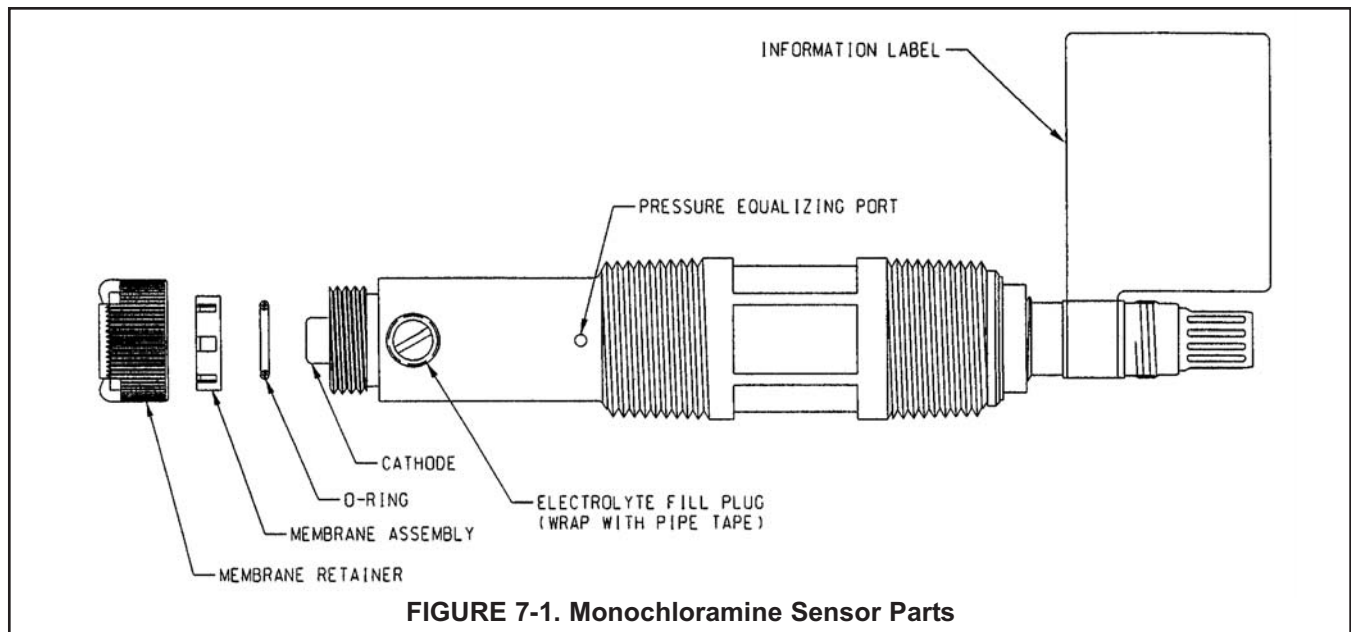

TABLE 7-1. Spare Parts

23750-00	Electrolyte Fill Plug with Wooden Osmotic Pressure relief port
9550094	O-Ring, Viton 2-014
33521-00	Membrane Retainer
23501-09	Monochloramine Membrane Assembly: includes one membrane assembly and one O-ring
23502-09	Monochloramine Membrane Kit: includes 3 membrane assemblies and 3 O-rings
9210372	Monochloramine Sensor Fill Solution, 4 oz (120 mL)

7.3 CONSTANT HEAD FLOW CONTROLLER

7.3.1 General

After a period of time, deposits may accumulate in the constant head overflow chamber and in the tubing leading to the flow cell. Deposits increase the resistance to flow and cause the flow to gradually decrease. Loss of flow may ultimately have an impact on the sensor performance. The flow controller is designed to provide about 1.2 gal/hr (75 mL/min) flow. Loss of flow to about 0.5 gal/hr (30 mL/min) causes about a 5% decrease in sensor output.

7.3.2 Cleaning the flow controller

The low flow controller can be taken apart completely for cleaning. Use a strong flow of water to flush out the tubing. A pipe cleaner or a small bottlebrush can remove more adherent deposits. To prevent leaks, apply a thin layer of silicone grease (or equivalent) to the two O-rings at the base of overflow chamber and to the O-ring sealing the central overflow tube to the base.

7.3.3 Other Maintenance

Table 7-2 and Figure 7-2 show the replacement parts for the flow controller assembly used in Model MCL.

TABLE 7-2. Replacement parts for constant head flow controller assembly (Model MCL)

Location in Figure 7-2	PN	Description	Shipping Weight
1	24091-01	Flow cell for chlorine sensor with bubble shedding nozzle	1 lb/0.5 kg
2	24040-00	O-ring kit, two 2-222 and one 2-024 silicone O-rings, with lubricant	1 lb/0.5 kg
3	33812-00	Dust cap for constant head flow controller	1 lb/0.5 kg
4	9322032	Elbow, 1/4 in FNPT x 1/4 in OD tubing	1 lb/0.5 kg
5	9350029	Check valve, 1/4 in FNPT	1 lb/0.5 kg

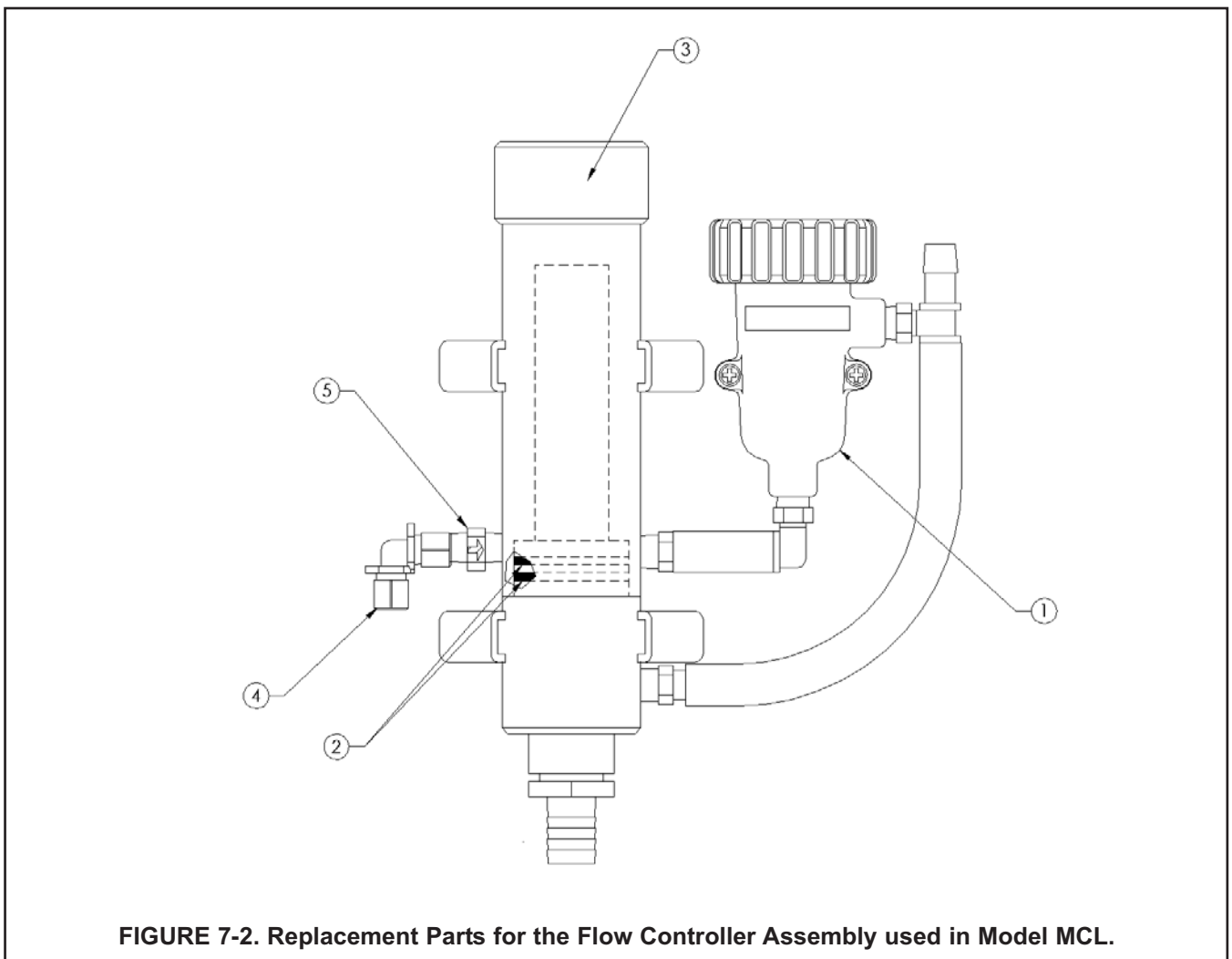

SECTION 8.0 TROUBLESHOOTING

8.1 OVERVIEW

The analyzer continuously monitors itself and the sensor for problems. When the analyzer identifies a problem, the word **warning** or **fault** appears intermittently in the lower line of the main display. When the **fault** or **warning** message appears, press the DIAG (diagnostic) key for more information. See Section 8.2.

A **warning** means the instrument or sensor is usable, but steps should be taken as soon as possible to correct the condition causing the warning.

A **fault** means the measurement is seriously in error and is not to be trusted. A fault condition might also mean that the analyzer has failed. Fault conditions must be corrected immediately. When a fault occurs the analog output goes to 22.00 mA or to the value programmed in Section 5.3.2.

The analyzer also displays warning messages if a calibration is seriously in error. For more information see Section 8.3.

8.2 USING THE DIAGNOSTIC FEATURE

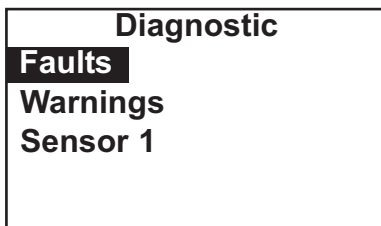

1. To read diagnostic messages, press DIAG. The screen at left appears. To display fault messages, select **Fault**. To display **Warning** messages select warning. To read measurement information about the sensor including raw sensor signal and calibration data, choose **Sensor 1** and press ENTER.

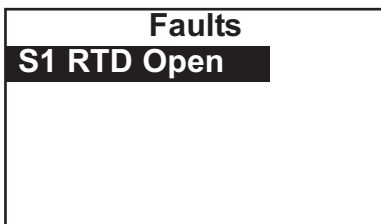

2. If you choose **Fault** or **Warning**, a screen like the one shown at left appears. **S1** means sensor 1. For additional troubleshooting information, select the desired message and press ENTER. For more information, see Section 8.3.

3. To return to the main display, press MENU then EXIT

8.3 TROUBLESHOOTING WHEN A FAULT MESSAGE IS SHOWING

Fault message	Explanation	Section
Main Board CPU Error	Main board software is corrupted	8.3.1
Main Board Factory Data	Main board factory eeprom data is corrupted	8.3.1
Main Board User Data	Main board user eeprom data is corrupted	8.3.1
Sensor Hardware Error	Missing or bad hardware component	8.3.2
Sensor Board Unknown	Analyzer does not recognize sensor board	8.3.3
Sensor HW-SW Mismatch	Sensor board hardware and software do not match	8.3.3
Sensor Incompatible	Sensor board software is not supported by main board software	8.3.4
Sensor Not Communicating	Sensor board is not communicating with main board	8.3.3
Sensor CPU Error	Sensor board software is corrupted	8.3.5
Sensor RTD Open	Temperature measuring circuit is open	8.3.6
S1 Not Detected	No sensor board is connected to sensor 1 terminal	8.3.7
Sensor Factory Data	Sensor board factory eeprom data is corrupted	8.3.8
Sensor EEPROM Write Error	Bad CPU on the sensor board	8.3.8
Sensor User Data	Sensor board user eeprom data is corrupted	8.3.8
Sensor ADC Error	Bad component on the sensor board	8.3.9
Sensor RTD Out of Range	RTD is improperly wired or has failed	8.3.10

8.3.1 Main Board CPU, Main Board Factory Data, and Main Board User Data Errors.

These error messages mean the main board software is corrupted or the eeprom data on the main board is corrupted.

1. Cycle the power off then on.
2. If cycling the power does not help, call the factory. The main board must be replaced. To do this, the analyzer must be returned to the factory.
3. If cycling the power does not help **and the fault message was Main Board User Data**, reset the analyzer to factory default and re-enter user settings and repeat calibration.

8.3.2 Hardware Error.

Hardware error means there is a missing or bad hardware component on the sensor board. The board must be replaced.

8.3.3 Sensor Board Unknown, Sensor Board HW (Hardware) or SW (Software) Mismatch, or Sensor Board Not Communicating.

These error messages mean the main board either does not recognize the sensor board or the sensor board and main board are no longer communicating.

1. Verify that the ribbon cable connecting the main board (on the inside of the front panel) and the sensor board are properly seated. Inspect the connecting cable for obvious tears or breaks.
2. If the ribbon cable is properly seated and appears undamaged, the sensor board should be replaced.

8.3.4 Sensor Incompatible

This error message means that the sensor board software is not supported by the main board software. Either the sensor board or the main board software is too old.

Replace the main board with one compatible with the sensor board. Call the factory for assistance. You will be asked for the main and sensor board software revision numbers. To read the main board software revision, press the DIAG key and scroll down until **Instr SW Ver** is showing. To view the sensor board software revision, press the DIAG key, choose the appropriate sensor, and scroll down until **Board SW Ver** is showing. The main board can be replaced only at the factory.

8.3.5 Sensor CPU Error

This message means the sensor board software is corrupted.

1. Cycle the power off then on.
2. If cycling the power does not help, call the factory. The sensor board must be replaced.

8.3.6 Sensor RTD Open

The sensor used in the MCL contains a Pt 100 RTD (resistance temperature device) for measuring temperature. Sensor RTD open means the temperature measuring circuit is open.

1. Confirm that the sensor RTD wires are properly connected.
2. Confirm that the Variopol connector is properly seated.
3. Disconnect the sensor from the cable and use an ohmmeter to check the resistance across the RTD. See Figure 8-1. At room temperature it should be about 110Ω. If the resistance is very high, the RTD has failed and the sensor must be replaced. If the resistance is okay, connect the Variopol cable to the sensor and disconnect the three RTD wires at the analyzer. Measure the resistance across the red and white RTD leads. See Figure 8.3. If the resistance is very high, the problem is with the VP cable, and it must be replaced.

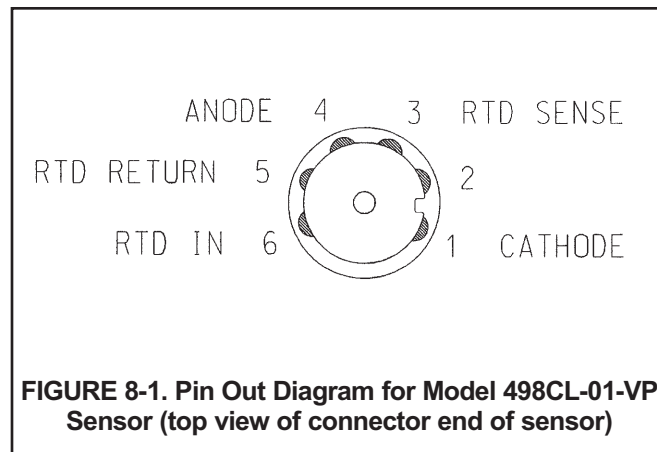
**8.3.7 Sensor 1 Not Detected**

The ribbon cable from sensor 1 (chlorine) board must be plugged into the sensor 1 plug. See Figure 3-2 for the location of the sensor board connectors.

1. Confirm that the ribbon cable connecting sensor 1 (chlorine) board to the main board is plugged into the Sensor 1 connector on the main board.
2. Confirm that the ribbon cable is seated at both ends.

8.3.8 Sensor Factory Data, Sensor Board User Data, and Sensor EEPROM Write Error

These messages mean factory eeprom data or user eeprom data on the sensor board is corrupted or the CPU on the sensor board is bad.

1. Cycle power off then on.
2. Replace the sensor board.

8.3.9 Sensor ADC Error

There is a bad component on the sensor board. The sensor board must be replaced.

8.3.10 Sensor RTD Out of Range

The sensor contains a Pt 100 RTD (resistance temperature device) for measuring temperature. If the measured resistance is outside the expected range, the analyzer will display the out of range error message.

1. Check wiring connections.
2. Disconnect the sensor from the cable and use an ohmmeter to check the resistance across the RTD. See Figure 8-1. The resistance should be about 110 Ω . If there is an open or short circuit, the sensor has failed and should be replaced. If the resistance is acceptable, attach the sensor to the Variopol cable and disconnect the red and white RTD IN and RTD RTN leads at the analyzer. Connect an ohmmeter across the leads and measure the resistance. If the circuit is open or shorted, the cable must be replaced.
3. If there is no open or short, check the analyzer. See Section 8.8.2.

8.4 TROUBLESHOOTING WHEN A WARNING MESSAGE IS SHOWING

Warning message	Explanation	Section
Sensor Need Factory Cal	The sensor board was not calibrated at the factory.	8.4.1
Sensor Negative Reading	The monochloramine reading is less than -0.5 ppm.	8.4.2
Sensor RTD Sense Open	RTD sensor line is broken or not connected	8.4.3
Sensor Temperature High	Temperature is greater than 155°C (311°F)	8.4.4
Sensor Temperature Low	Temperature is less than -20°C (-4°F)	8.4.4

8.4.1 Sensor Need Factory Cal

The sensor board was improperly calibrated at the factory. Call the factory for assistance.

8.4.2 Sensor Negative Reading

The analyzer converts the raw sensor current to ppm monochloramine by subtracting the zero current from the raw current and multiplying the result by a conversion factor. If the zero current is larger than the raw current, the result will be negative.

1. Check the zero current. It should be less than about 15 nA. If it is greater than 15 nA, repeat the zero step.
2. If the zero current is in the correct range, the negative reading might be the result of the raw current or the sensitivity being too low. A properly operating sensor should generate between 250 and 450 nA for every 1 ppm of monochloramine. Recalibrate the sensor. If necessary, clean or replace the membrane and check the fill solution.
3. Replace the sensor.

8.4.3 Sensor RTD Sense Open

The analyzer measures temperature using a three-wire RTD. See Figure 8.3. The in and return leads are used to measure the resistance of the RTD. The third lead, called the sense line, is connected to the return lead at the sensor. The sense line allows the analyzer to correct for the resistance of the in and return leads and to compensate for changes in lead resistance caused by changes in ambient temperature.

1. Check sensor wiring, particularly the red, white, and white/red RTD leads.
2. Disconnect the white and white/red sense and return leads and measure the resistance between them. It should be less than 1Ω. See Figure 8.3.
3. Even though the sense line is open, the sensor is still usable. Use a wire jumper to connect the sense and return terminals on the sensor terminal strip. The temperature reading will no longer be corrected for the lead resistance, nor will the analyzer be able to compensate for changes in ambient temperature. The error could be several °C or more.
4. Replace the sensor.

8.4.4 Sensor Temperature High or Low

The sensor RTD is most likely miswired.

1. Check wiring connections.
2. Check resistance between RTD in and return leads. The resistance should be close to the values given in Section 8.8.2.
3. Replace sensor.

8.5 TROUBLESHOOTING WHEN NO ERROR MESSAGE IS SHOWING

Problem	See Section
Zero current was accepted, but the current is outside the range -10 to 15 nA	8.5.1
Error or warning message appears while zeroing the sensor (zero current is too high)	8.5.1
Zero current is unstable	8.5.2
Sensor can be calibrated, but the current is less than about 250 nA/ppm at 25°C	8.5.3
Process readings are erratic	8.5.4
Readings drift	8.5.5
Sensor does not respond to changes in monochloramine level	8.5.6
Readings are too low	8.5.7

8.5.1 Zero current is too high

1. Is the sensor properly wired to the analyzer? See Section 3.2.
2. Is the zero solution monochloramine-free? Take a sample of the solution and test it for monochloramine level. The concentration should be less than 0.02 ppm.
3. Has adequate time been allowed for the sensor to reach a minimum stable residual current? It may take several hours, sometimes as long as overnight, for a new sensor to stabilize.
4. Check the membrane for damage and replace it if necessary. Be careful not to touch the membrane or cathode. Touching the cathode mesh may damage it.

8.5.2 Zero current is unstable

1. Is the sensor properly wired to the analyzer? See Section 3.2. Verify that all wiring connections are tight.
2. Readings are often erratic when a new or rebuilt sensor is first placed in service. Readings usually stabilize after about an hour.
3. Is the space between the membrane and cathode mesh filled with electrolyte solution? Often the flow of electrolyte can be started by simply holding the sensor with the membrane end pointing down and sharply shaking the sensor a few times as though shaking down a clinical thermometer.
4. Verify that the sensor is filled with electrolyte solution. Refer to Section 7.2 for details.

8.5.3 Sensor can be calibrated, but the current is too low

1. Is the temperature low? The sensor current decreases about 5% for every °C drop in temperature.
2. Sensor current depends on the rate of sample flow past the sensor tip. If the flow is too low, monochloramine readings will be low. Be sure the liquid level in the constant head flow controller is level with the central overflow tube and that excess sample is flowing down the tube. If necessary, disassemble and clean the overflow sampler. See Section 7.3.
3. Is a bubble trapped against the membrane? If a sample flow becomes too low (because dirt or slime has built up on in the flow controller), bubbles will have a tendency to collect on the membrane. The bubble reduces the active area of the membrane, and readings drop. The design flow (2 gph) is adequate to push away bubbles. See Section 7.3 for cleaning procedure.
4. Low current can be caused by lack of electrolyte flow to the cathode and membrane. See step 3 in Section 8.5.2.
5. When was the sensor fill solution last replaced? The monochloramine sensor loses sensitivity, that is, it generates less current per ppm of monochloramine, as it operates. Gradual loss of sensitivity can usually be compensated for by calibrating the sensor weekly. After about two or three months of operation, the sensitivity may start to drop rapidly. At this point, the electrolyte solution and membrane should be replaced. Refer to section 7.2.
6. Is the membrane fouled or coated? A dirty membrane inhibits diffusion of monochloramine through the membrane, reducing the sensor current and increasing the response time. Clean the membrane by swirling it vigorously in a beaker of water or by washing with a stream of water from a washer bottle. DO NOT use a tissue to wipe the membrane.
7. If cleaning the membrane does not improve the sensor response, replace the membrane and electrolyte solution. See the sensor instruction sheet for details.

8.5.4 Process readings are erratic

1. Readings are often erratic when a new sensor or rebuilt sensor is first placed in service. The current usually stabilizes after a few hours.
2. Verify that wiring is correct. Pay particular attention to shield and ground connections.
3. Is the membrane in good condition and is the sensor filled with electrolyte solution? Replace the fill solution and electrolyte. Refer to section 7.2.

8.5.5 Readings drift

1. Is the sample temperature changing? Membrane permeability is a function of temperature. The time constant for the sensor is about five minutes. Therefore, the reading may drift for a while after a sudden temperature change.
2. Is the membrane clean? For the sensor to work properly, monochloramine must diffuse freely through the membrane. A coating on the membrane will interfere with the passage of monochloramine, resulting in slow response. Clean the membrane by rinsing with a stream of water from a wash bottle or by swirling it vigorously in a beaker of water. **DO NOT** use a tissue to wipe the membrane.
3. Is the sample flow within the recommended range? Gradual loss of sample flow will cause a downward drift. Be sure the liquid level in the constant head flow controller is level with the central overflow tube and that excess sample is flowing down the tube. If necessary, disassemble and clean the overflow sampler. See Section 7.3.
4. Is a bubble trapped against the membrane? If a sample flow becomes too low (because dirt or slime has built up on in the flow controller), bubbles will have a tendency to collect on the membrane. The bubble reduces the active area of the membrane, and readings drop. The design flow (2 gph) is adequate to push away bubbles. See Section 7.3 for cleaning procedure.
5. Is the sensor new or has it been recently serviced? New or rebuilt sensors may require several hours to stabilize.
6. Gradual downward drift is caused by depletion of the fill solution. Normally, calibrating the sensor every week adequately compensates for the drift. After the sensor has been in service for several months, it will probably be necessary to replace the fill solution and membrane. Refer to section 7.2

8.5.6 Sensor does not respond to changes in monochloramine level.

1. Is the grab sample test accurate? Is the grab sample representative of the sample flowing to the sensor?
2. When was the sensor fill solution last replaced? The monochloramine sensor loses sensitivity, that is, it generates less current per ppm of monochloramine, as it operates. After about two or three months of operation, the sensitivity may start to drop rapidly. If the fill solution is extremely old, the sensor may be completely non-responsive to monochloramine. Replace the fill solution and membrane. See the sensor instruction manual for details.
3. Is the membrane clean? Clean the membrane with a stream of water and replace it if necessary.
4. Is a bubble trapped against the membrane? If a sample flow becomes too low (because dirt or slime has built up on in the flow controller), bubbles will have a tendency to collect on the membrane. The bubble reduces the active area of the membrane, and readings drop. The design flow (2 gph) is adequate to push away bubbles. See Section 7.3 for cleaning procedure.
5. Replace the sensor.

8.5.7 Readings are too low.

1. Was the sample tested as soon as it was taken? Monochloramine solutions are moderately unstable. Test the sample immediately after collecting it. Avoid exposing the sample to sunlight.
2. When was the sensor fill solution last replaced? The monochloramine sensor loses sensitivity, that is, it generates less current per ppm of monochloramine, as it operates. Generally, calibrating the sensor every week compensates for the gradual loss in sensitivity. After about two or three months of operation, the sensitivity may start to drop rapidly. At this point, the electrolyte solution and membrane should be replaced. Refer to section 7.2.
3. Low readings can be caused by zeroing the sensor before the residual current has reached a stable minimum value. Residual current is the current the sensor generates even when no monochloramine is in the sample. Because the residual current is subtracted from subsequent measured currents, zeroing before the current is a minimum can lead to low results.

Example: The true residual current for a monochloramine sensor is 20 nA, and the sensitivity is 400 nA/ppm. Assume the measured current is 600 nA. The true concentration is $(600-20)/400$ or 1.45 ppm. If the sensor was zeroed prematurely when the current was 40 nA, the measured concentration will be $(600-40)/400$ or 1.40 ppm. The error is 3.5%. Suppose the measured current is 800 nA. The true concentration is 1.95 ppm, and the measured concentration is 1.90 ppm. The error is now 2.6%. The absolute difference between the reading remains the same, 0.05 ppm.

4. Sensor response depends on flow. If the flow is too low, readings will be low and flow sensitive. Be sure the liquid level in the constant head flow controller is level with the central overflow tube and that excess sample is flowing down the tube. If necessary, disassemble and clean the overflow sampler. See Section 7.3.
5. Is a bubble trapped against the membrane? If a sample flow becomes too low (because dirt or slime has built up on in the flow controller), bubbles will have a tendency to collect on the membrane. The bubble reduces the active area of the membrane, and readings drop. The design flow (2 gph) is adequate to push away bubbles. See Section 7.3 for cleaning procedure.

8.6 TROUBLESHOOTING WHEN NO ERROR MESSAGE IS SHOWING — GENERAL

Problem	See Section
New temperature during calibration more than 2-3°C different from the live reading	8.6.1
Current output is too low	8.6.2
Alarm relays do not operate when setpoint is exceeded	8.6.3
Bubbles trapped against membrane	8.6.4

8.6.1 Difference Between Analyzer and Standard Thermometer is Greater than 3°C.

1. Is the reference thermometer, RTD, or thermistor accurate? General purpose thermometers, particularly ones that have been mistreated, can have surprisingly large errors.
2. Review Section 6.2.2.

8.6.2 Current Output Too Low.

Load resistance is too high. Maximum load is 600 Ω.

8.6.3 Alarm Relays Do Not Work

1. Verify the relays are properly wired.
2. Verify the deadband is correctly configured.

8.6.4 Bubbles Trapped Against Membrane.

If the flow against the sensor is too low, bubbles can get trapped against the membrane. Normally, low flow is caused by dirt or slime building up in the flow system tubing. See Section 7.3 for cleaning procedure.

8.7 SIMULATING INPUTS

To check the performance of the analyzer, use a decade box and battery to simulate the current from the sensor. The battery, which opposes the polarizing voltage, is necessary to ensure that the sensor current has the correct sign.

1. Disconnect the anode and cathode leads from terminals 8 and 10 on TB1 and connect a decade box and battery as shown in Figure 8-2. It is not necessary to disconnect the RTD leads.
2. Set the decade box to the resistance shown below.

Polarizing Voltage	Resistance	Expected Current
400 mV	3 MΩ	400 nA

3. Note the sensor current. It should be close to the value in the table. The actual value depends on the voltage of the battery. To view the sensor current, go to the main display and press DIAG. choose **Sensor 1**. The input current is the first line in the display.
4. Change the decade box resistance and verify that the correct current is shown. Calculate current from the equation:

$$\text{current (nA)} = \frac{V_{\text{battery}} - V_{\text{polarizing (mV)}}}{\text{resistance (M}\Omega\text{)}}$$

The voltage of a fresh 1.5 volt battery is about 1.6 volt (1600 mV).

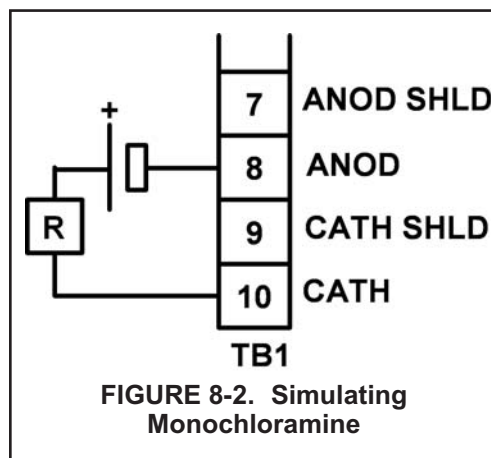

8.8 SIMULATING TEMPERATURE

8.8.1 General.

The MCL analyzer accepts a Pt100 RTD. The Pt100 RTD is in a three-wire configuration. See Figure 8-3.

8.8.2 Simulating temperature

To simulate the temperature input, wire a decade box to the analyzer or junction box as shown in Figure 8-4.

To check the accuracy of the temperature measurement, set the resistor simulating the RTD to the values indicated in the table and note the temperature readings. The measured temperature might not agree with the value in the table. During sensor calibration an offset might have been applied to make the measured temperature agree with a standard thermometer. The offset is also applied to the simulated resistance. The MCL is measuring temperature correctly if the difference between measured temperatures equals the difference between the values in the table to within $\pm 0.1^\circ\text{C}$.

For example, start with a simulated resistance of $103.9\ \Omega$, which corresponds to 10.0°C . Assume the offset from the sensor calibration was $-0.3\ \Omega$. Because of the offset, the analyzer calculates temperature using $103.6\ \Omega$. The result is 9.2°C . Now change the resistance to $107.8\ \Omega$, which corresponds to 20.0°C . The analyzer uses $107.5\ \Omega$ to calculate the temperature, so the display reads 19.2°C . Because the difference between the displayed temperatures (10.0°C) is the same as the difference between the simulated temperatures, the analyzer is working correctly.

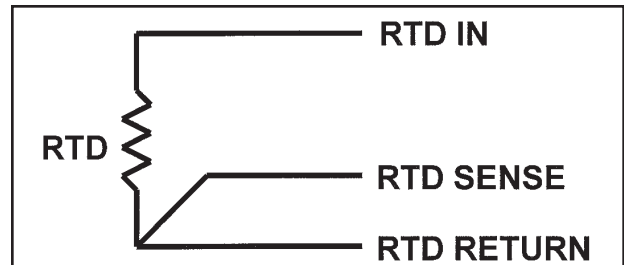

FIGURE 8-3. Three-Wire RTD Configuration.

Although only two wires are required to connect the RTD to the analyzer, using a third (and sometimes fourth) wire allows the analyzer to correct for the resistance of the lead wires and for changes in the lead wire resistance with temperature.

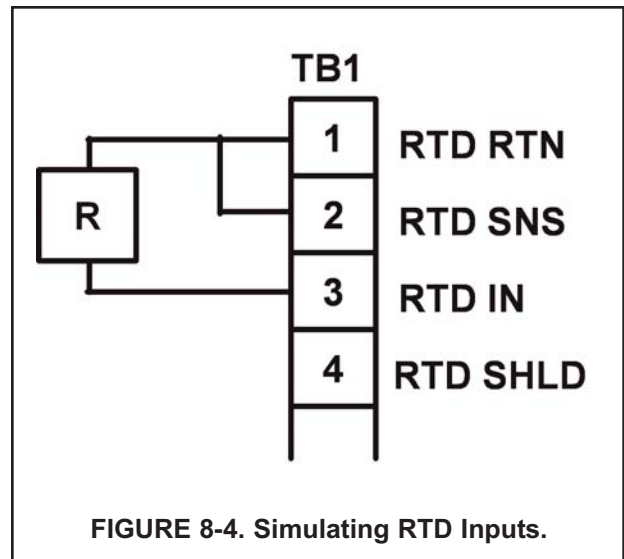

FIGURE 8-4. Simulating RTD Inputs.

Temp. ($^\circ\text{C}$)	Pt 100 (Ω)
0	100.0
10	103.9
20	107.8
25	109.7
30	111.7
40	115.5
50	119.4
60	123.2
70	127.1
80	130.9
85	132.8
90	134.7
100	138.5

NOTES



The right people, the right answers, right now.

Immediate, Reliable Analytical Support

Now there's a way to quickly get the right answers for your liquid analytical instrumentation questions: the Analytical Customer Support Center.

Our staff of trained professionals is ready to provide the information you need. If you are placing an order, verifying delivery, requesting application information, or just want to contact a Rosemount Analytical representative, a call to the Customer Support Center will provide you with the right people, the right answers, right now.

A Worldwide Network of Sales and Service

Emerson Process Management's field sales offices are your source for more information on the full line of Rosemount Analytical products. Field sales personnel will work closely with you to supply technical data and application information.

For more information, please contact your nearest Emerson Process Management sales office.

THE AMERICAS - HEADQUARTERS

Emerson Process Management
Liquid Division
2400 Barranca Parkway
Irvine, CA 92606
Phone: 949-757-8500
Toll Free: 800-854-8257
Fax: 949-474-7250

ASIA-PACIFIC

Emerson Process Management
Singapore Private Ltd.
1 Pandan Crescent
Singapore 0512
Republic of Singapore
Phone: 65-777-8211
Fax: 65-777-0947

EUROPE, MIDDLE EAST, AND AFRICA

Emerson Process Management
Heath Place
Bognor Regis
West Sussex PO22 9SH
England
Phone: 44-1243-863121
Fax: 44-1243-845354

ADDITIONAL SALES OFFICES IN:

Argentina	India	Romania
Australia	Indonesia	Russia
Austria	Ireland	Saudi Arabia
Azerbaijan	Israel	Singapore
Bahrain	Italy	Slovak Republic
Belgium	Jamaica	South Africa
Bolivia	Japan	Spain
Brazil	Jordan	Sweden
Brunei	Kazakhstan	Switzerland
Bulgaria	Korea	Syria
Canada	Kuwait	Taiwan
Chile	Malaysia	Thailand
China	Mexico	Tobago
Colombia	Netherlands	Trinidad
Costa Rica	New Zealand	Tunisia
Croatia	Nigeria	Turkey
Czech Republic	Norway	Ukraine
Denmark	Oman	United Arab Emirates
Egypt	Pakistan	United Kingdom
Ecuador	Paraguay	Uruguay
Finland	Peru	Uzbekistan
France	Philippines	Venezuela
Germany	Poland	Yemen
Greece	Portugal	
Hong Kong	Puerto Rico	
Hungary	Qatar	

VISIT OUR WEBSITE AT
www.raihome.com

WARRANTY

Seller warrants that the firmware will execute the programming instructions provided by Seller, and that the Goods manufactured or Services provided by Seller will be free from defects in materials or workmanship under normal use and care until the expiration of the applicable warranty period. Goods are warranted for twelve (12) months from the date of initial installation or eighteen (18) months from the date of shipment by Seller, whichever period expires first. **Consumables, such as glass electrodes, membranes, liquid junctions, electrolyte, o-rings, catalytic beads, etc., and Services are warranted for a period of 90 days from the date of shipment or provision.**

Products purchased by Seller from a third party for resale to Buyer ("Resale Products") shall carry only the warranty extended by the original manufacturer. Buyer agrees that Seller has no liability for Resale Products beyond making a reasonable commercial effort to arrange for procurement and shipping of the Resale Products.

If Buyer discovers any warranty defects and notifies Seller thereof in writing during the applicable warranty period, Seller shall, at its option, promptly correct any errors that are found by Seller in the firmware or Services, or repair or replace F.O.B. point of manufacture that portion of the Goods or firmware found by Seller to be defective, or refund the purchase price of the defective portion of the Goods/Services.

All replacements or repairs necessitated by inadequate maintenance, normal wear and usage, unsuitable power sources, unsuitable environmental conditions, accident, misuse, improper installation, modification, repair, storage or handling, or any other cause not the fault of Seller are not covered by this limited warranty, and shall be at Buyer's expense. Seller shall not be obligated to pay any costs or charges incurred by Buyer or any other party except as may be agreed upon in writing in advance by an authorized Seller representative. All costs of dismantling, reinstallation and freight and the time and expenses of Seller's personnel for site travel and diagnosis under this warranty clause shall be borne by Buyer unless accepted in writing by Seller.

Goods repaired and parts replaced during the warranty period shall be in warranty for the remainder of the original warranty period or ninety (90) days, whichever is longer. This limited warranty is the only warranty made by Seller and can be amended only in a writing signed by an authorized representative of Seller. Except as otherwise expressly provided in the Agreement, THERE ARE NO REPRESENTATIONS OR WARRANTIES OF ANY KIND, EXPRESS OR IMPLIED, AS TO MERCHANTABILITY, FITNESS FOR PARTICULAR PURPOSE, OR ANY OTHER MATTER WITH RESPECT TO ANY OF THE GOODS OR SERVICES.

RETURN OF MATERIAL

Material returned for repair, whether in or out of warranty, should be shipped prepaid to:

**Emerson Process Management
Liquid Division
2400 Barranca Parkway
Irvine, CA 92606**

The shipping container should be marked:

Return for Repair

Model _____

The returned material should be accompanied by a letter of transmittal which should include the following information (make a copy of the "Return of Materials Request" found on the last page of the Manual and provide the following thereon):

1. Location type of service, and length of time of service of the device.
2. Description of the faulty operation of the device and the circumstances of the failure.
3. Name and telephone number of the person to contact if there are questions about the returned material.
4. Statement as to whether warranty or non-warranty service is requested.
5. Complete shipping instructions for return of the material.

Adherence to these procedures will expedite handling of the returned material and will prevent unnecessary additional charges for inspection and testing to determine the problem with the device.

If the material is returned for out-of-warranty repairs, a purchase order for repairs should be enclosed.



*The right people,
the right answers,
right now.*

**ROSEMOUNT ANALYTICAL
CUSTOMER SUPPORT CENTER
1-800-854-8257**



ON-LINE ORDERING NOW AVAILABLE ON OUR WEB SITE
<http://www.raihome.com>

Specifications subject to change without notice.



Credit Cards for U.S. Purchases Only.



Emerson Process Management

Liquid Division

2400 Barranca Parkway
Irvine, CA 92606 USA
Tel: (949) 757-8500
Fax: (949) 474-7250

<http://www.raihome.com>

