MAGNA Analog Output Options

- **MAO1** 4-20 mA

- **MAO2** 0-10V

- **MAO3** -10V to +10V



LAUREL Electronics, Inc.

3183-G Airway Ave, Costa Mesa, CA 92626, USA
Tel +1 714-434-6131 Fax +1 714-434-3766
www.laurels.com sales@laurels.com

Warranty

We warrant our products against defects in materials or workmanship for a period of one year from the date of purchase.

In the event of a defect during the warranty period, the unit should be returned, freight (and all duties and taxes) prepaid by the Buyer to the authorised distributor from where the unit was purchased.

The Distributor, at its option, will repair or replace the defective unit. The unit will be returned to the Buyer with freight charges prepaid by the distributor.

LIMITATION OF WARRANTY

The foregoing warranty shall not apply to defects resulting from:

1. Improper or inadequate maintenance by the buyer.
2. Unauthorised modification or misuse.
3. Operation outside the environmental specification of the product.
4. Mishandling or abuse.

The warranty set forth above is exclusive and no other warranty, whether written or oral is expressed or implied. We specifically disclaim the implied warranties of merchantability and fitness for a particular purpose.

EXCLUSIVE REMEDIES

The remedies provided herein are the buyer's sole and exclusive remedies.

In no event shall we be liable for direct, indirect, incidental or consequential damages (including loss of profits) whether based on contract, tort or any other legal theory.

Contents

General Description	4
Installation Hints	5
Wiring Advice	5
Zener Barriers	5
4-20 mA Available Responses	6
0-10V Available Responses	7
-10V to +10V Available Responses	8
Analog Output Board - Configuring	9
Scaling the Analog Output	10
Specifications	11
Record of Revisions	12
Warranty	2

Connections and Installing into a MAGNA Display. See main MAGNA manual.
Need a manual urgently? You can download manuals from our website.

General Description

This manual only covers the setup of the MAGNA analog output option. Please refer to the main display's operating manual for full specifications, installation methods, safety notices etc. You can download manuals from our website.

The analog output option allows you to create an isolated analog signal which is proportional to the value shown on the front of your display.

This can be used to feed remote devices such as data loggers, displays, PLCs and other peripheral equipment.

The outputs are active. That means the outputs are available directly, without needing external excitation power.

Two analog output boards are available:

1. Unipolar output board -(options MAO1 or MAO2), which can be configured to give an output of 0-20 mA, 4-20 mA or 0-10V.
2. Bipolar output board (option MAO3), which gives an output of -10V to +10V.

These analog output options have high resolution and precision, thanks to their 16-bit D/A architecture.

Scaling the output to cover your required measurement range is simple and only takes a few minutes.

You will easily find the analog output setting button on the front of the display, it is the one marked OUTPUT, so you can get to the setting directly, without needing to find it in a menu.

The analog output is derived from the displayed value, so if you adjust filtering for the display, the analog output will also be filtered and will respond to any input changes at the same speed as the display.

The analog output is updated 10 times per second.

Installation Hints for Best Performance

This section offers several suggestions which will help you get the best performance from your analog output.

1. Use good quality twisted-pair screened signal cable. Belden 8761NH (single pair), Belden 8777NH (multi-pair), Belden 9503 (multi-pair) or AlphaWire 6010C (multi-pair) are good choices available from many electrical distributors.
2. The cable should be routed away from noisy wiring and devices such as power feeds from inverters, discharge-lighting cables, welder cabling etc, and should preferably be routed in a dedicated low voltage signalling / instrumentation conduit or cable tray.
3. Screened cable should be earthed at the destination end only.
4. All wires and screens coming out of the screened cable should be kept as short as possible to minimise pickup of noise.
5. If you are using barriers, you should earth your screen as shown below, paying particular care that you do not earth both ends of any run of of cable.
6. If you are feeding the analog output to a PLC, data logger or other device with an A/D converter, you should set a sample time of around 100 mS and ensure that the signal is averaged during this period. This will ensure optimum noise performance without degrading response speed.

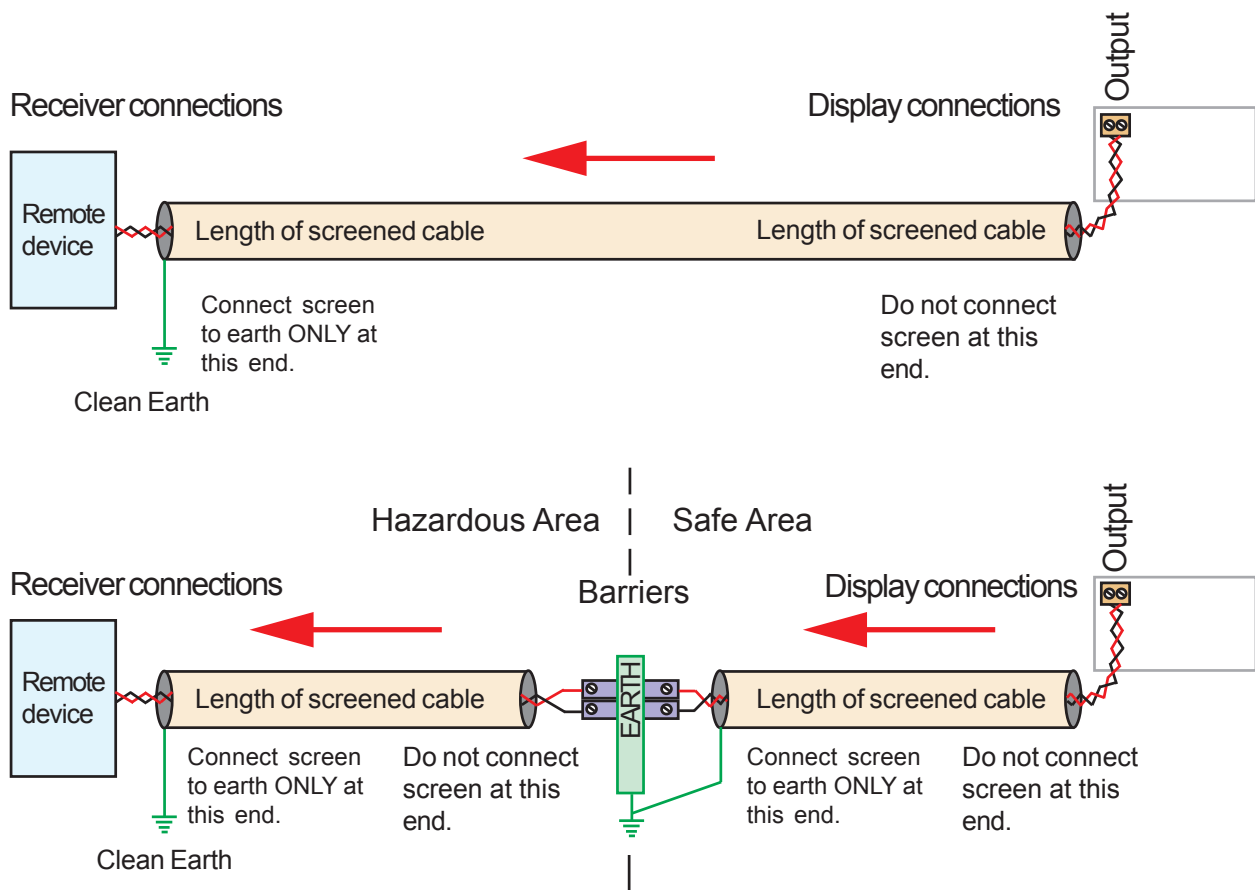

MAO1 4-20 mA Output, Available Responses

Complete flexibility and simplicity of scaling for your 4-20 mA analog output signal. Directly proportional and inversely proportional, symmetrical and assymetrical, zero based display and offset display, all set with just 2 parameters!

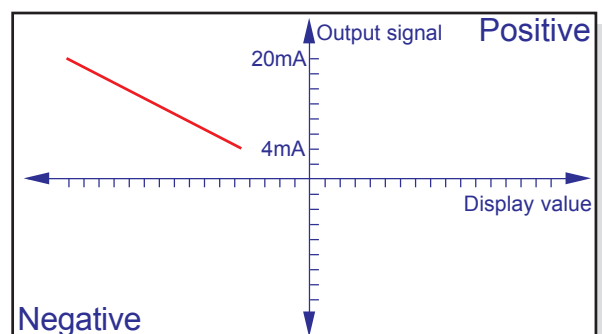
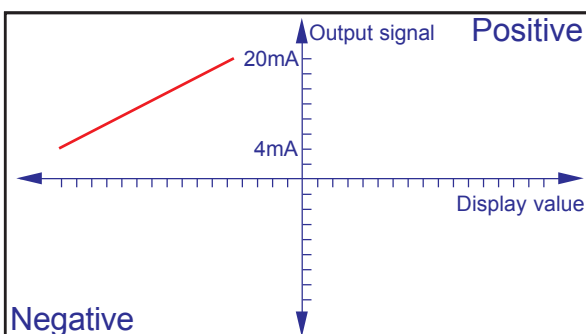
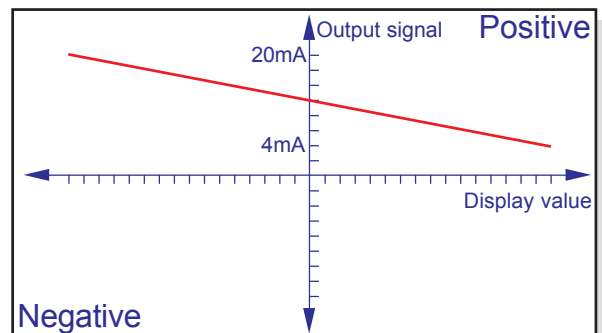
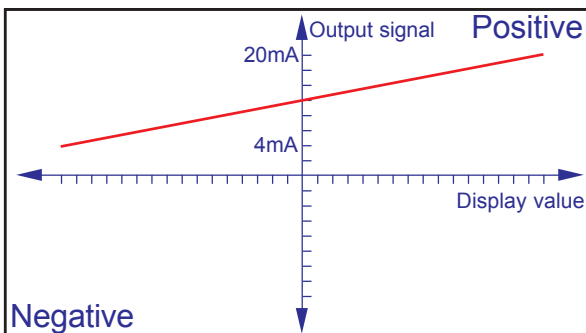
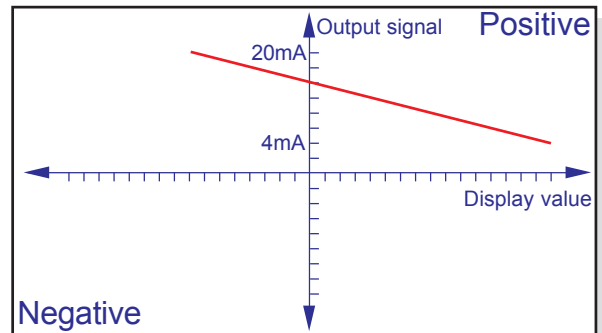
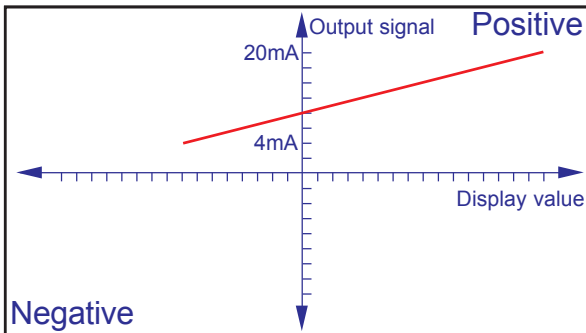
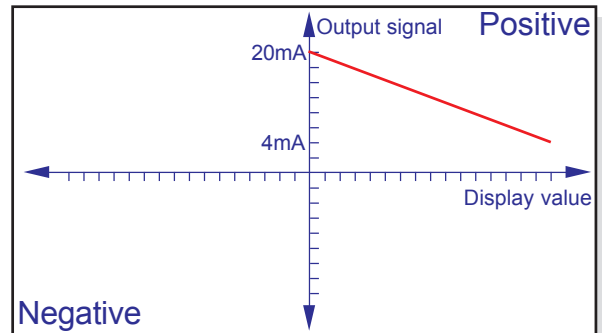
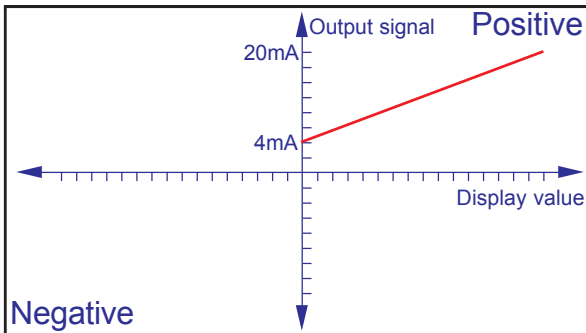
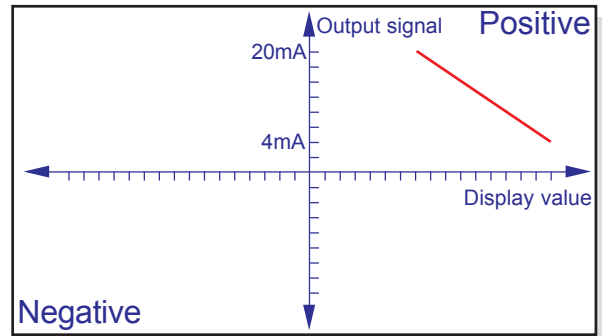
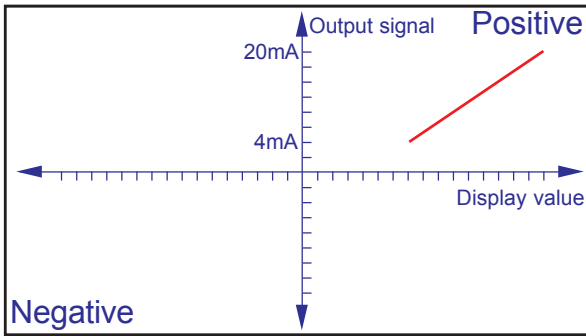

MAO2 0-10V Output, Available Responses

Complete flexibility and simplicity of scaling for your 0-10V analog output signal. Directly proportional and inversely proportional, symmetrical and assymetrical, zero based display and offset display, all set with just 2 parameters!

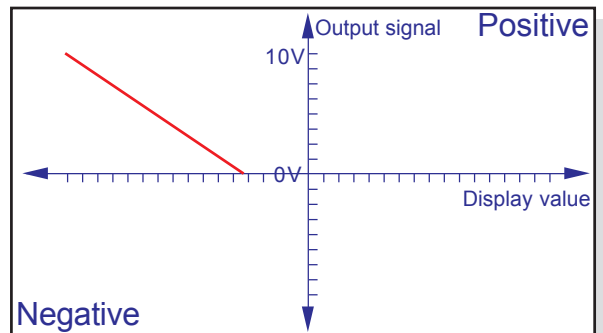
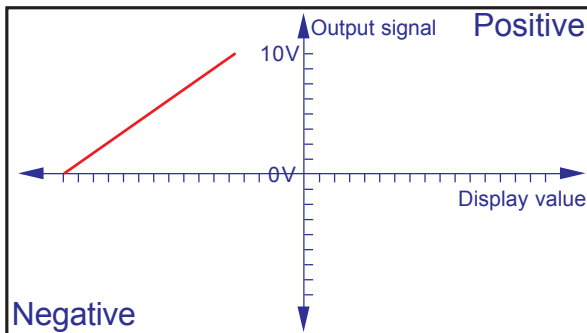
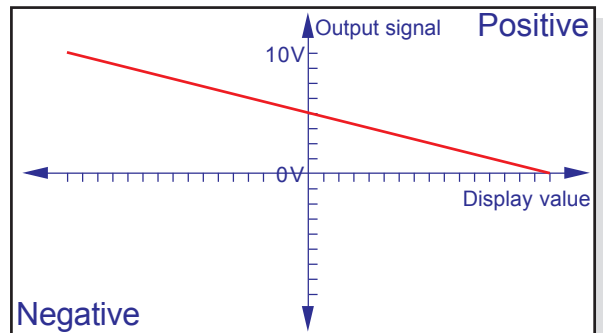
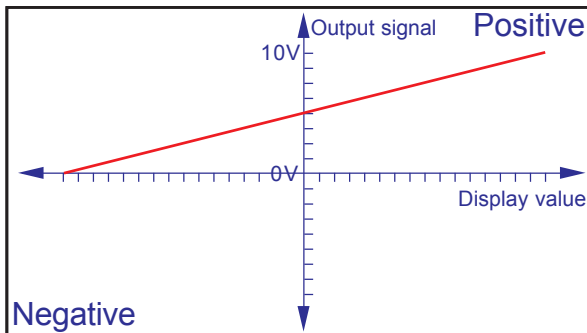
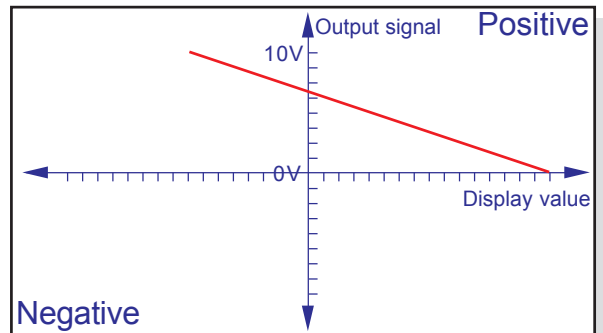
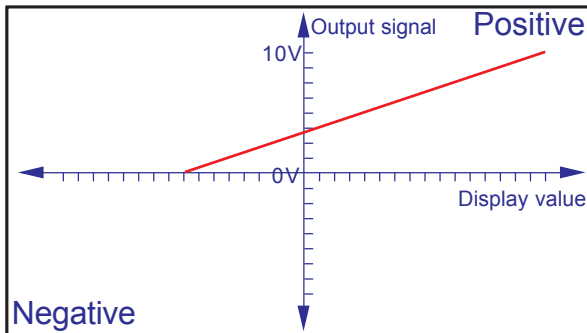
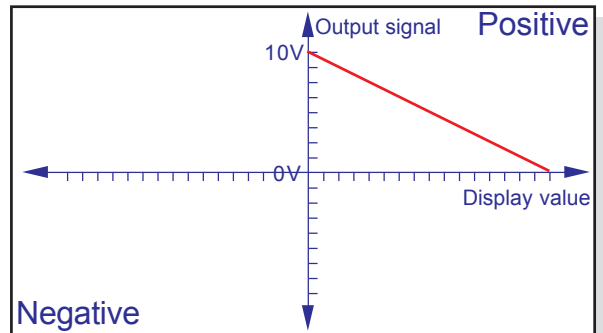
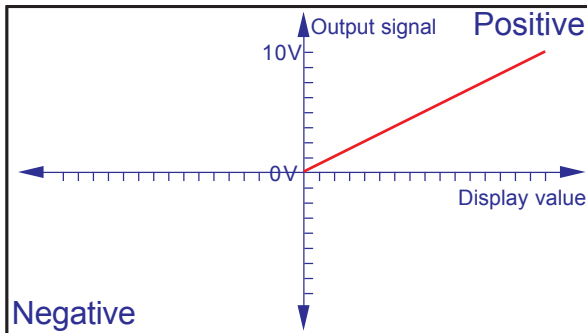
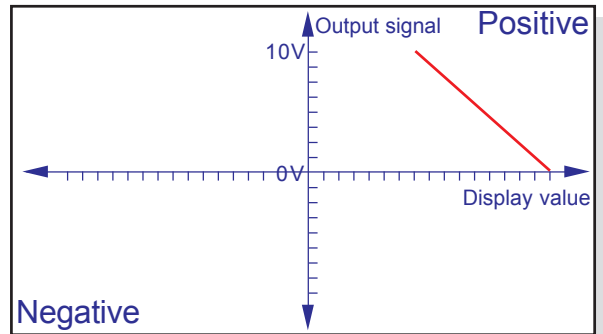
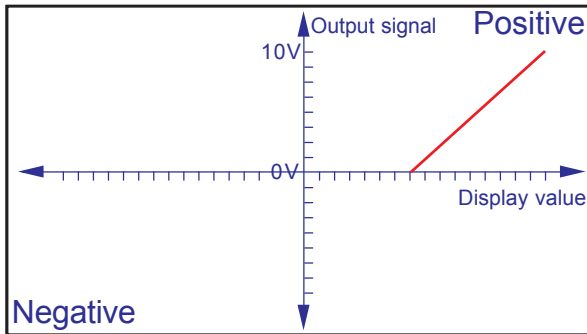

MAO3 -10V to +10V Available Responses

Complete flexibility and simplicity of scaling for your -10V to +10V analog output signal. Directly proportional and inversely proportional, symmetrical and asymmetrical, zero based display and offset display, all set with just 2 parameters!

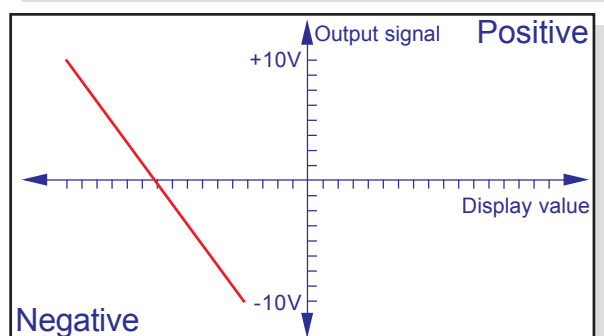
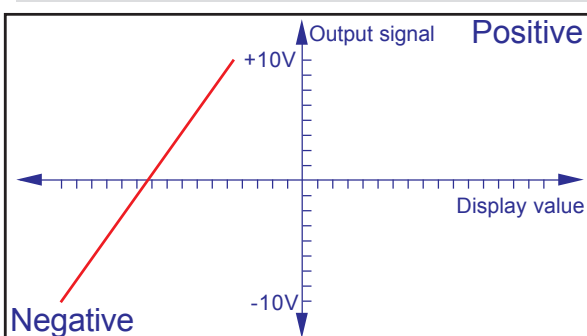
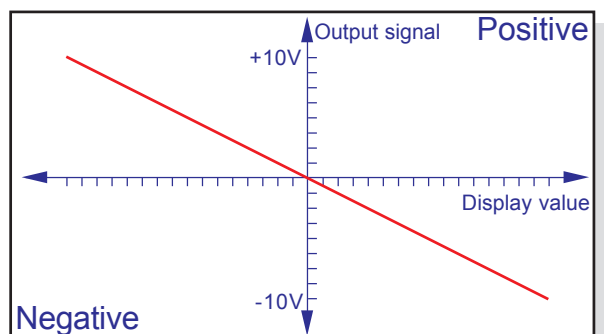
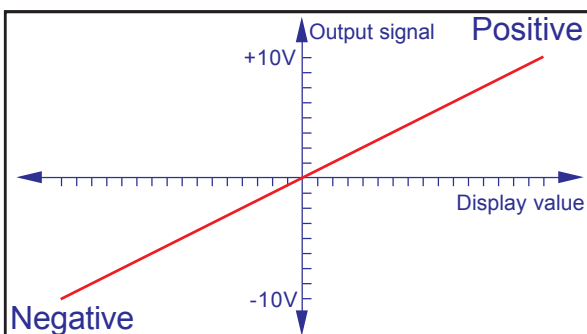
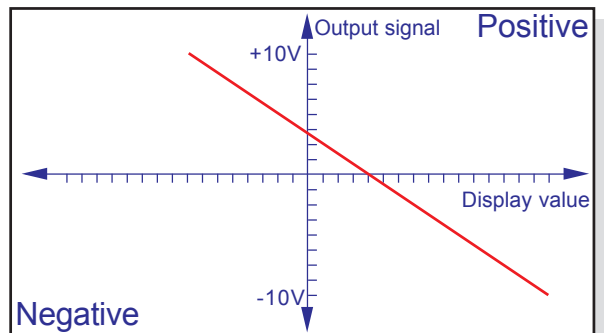
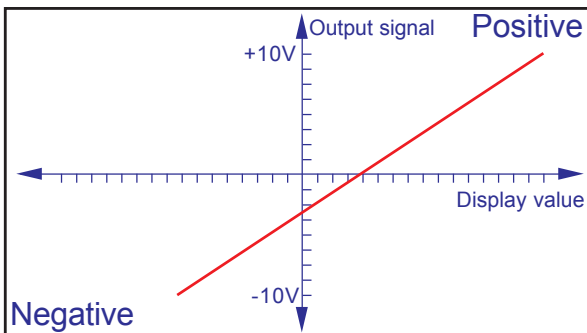
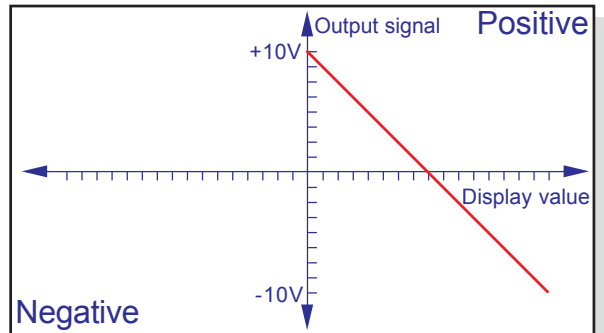
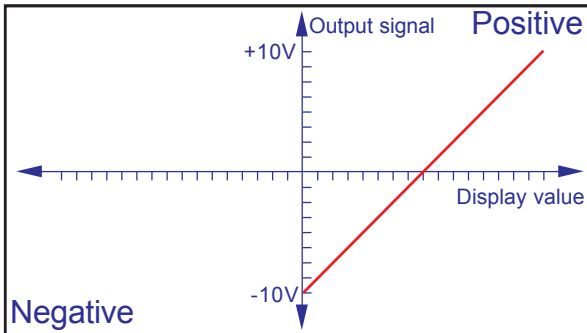
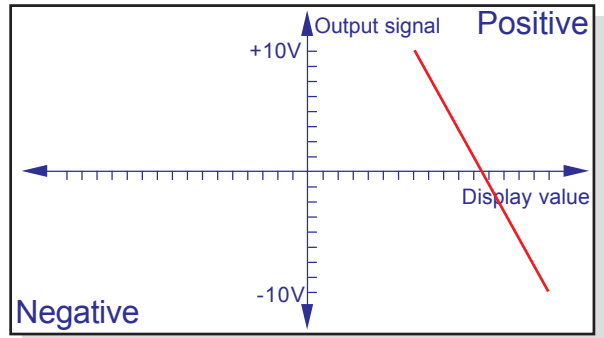
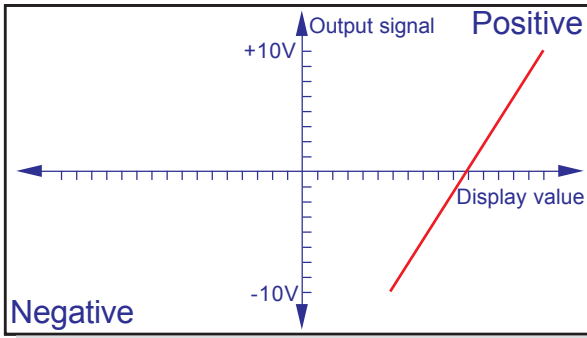

Analog Output Board Configuration

You can adjust your display to generate an analog output over a chosen numeric display range.

For example you could have 4-20 mA output, where 4 mA occurs at 0 on the display and 20 mA occurs at 2500.0 on the display. Or, you may want the analog output to be reverse acting, so you could set 4 mA to occur at 500 on the display and 20 mA to occur at 125 on the display.

You have complete freedom on the numeric display limits which correspond to your analog output. They can both be positive, one negative and one positive, or both negative.

There are two board types, one for single polarity output such as 4-20 mA and 0-10V, the other for -10V to +10V output. The appropriate one will be fitted in your display, according to your order.

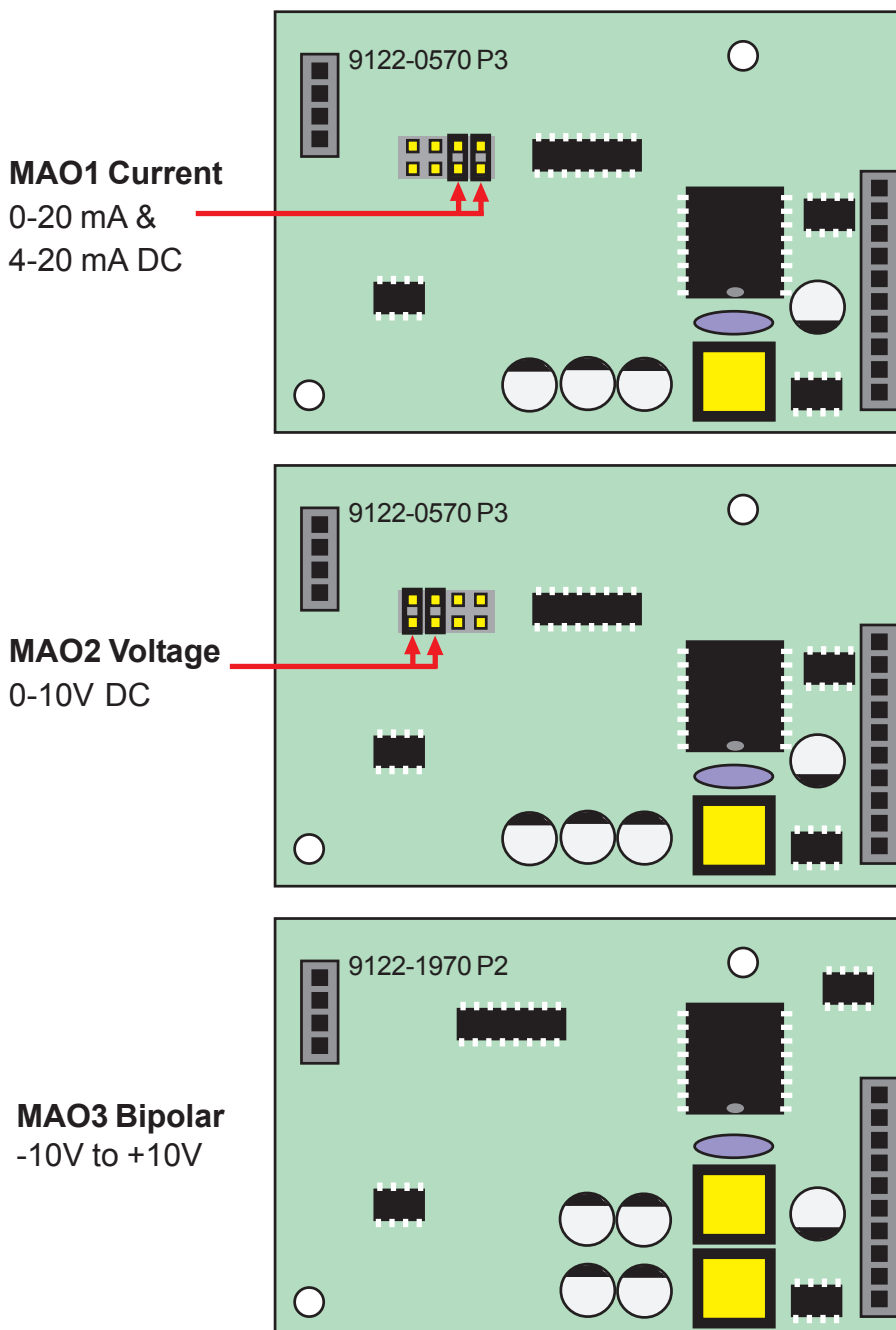

Scaling your Analog Output

1

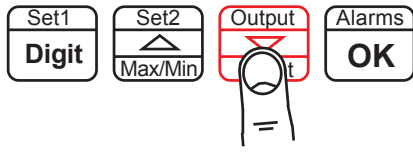

Press for 3 seconds

Lockout Switch must be OFF



Circuit board ON

2

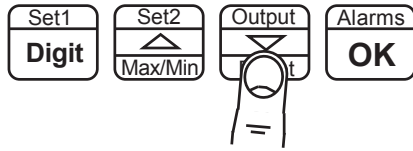

Press to toggle between 0-20 mA and 4-20 mA if board jumpers are set for current

Display shows **OutPut** followed by the present output range of either 4-20mA, 0-20mA, 0-10V or Bipolar -10 to +10V

If your display does not yet have an analog output board fitted, the display will show **no OPt**

Press "OK" when ready for next step...

3

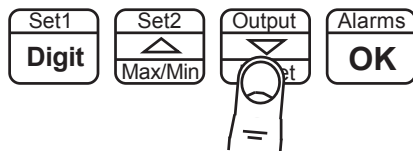

Press to select Net or Gross

Now choose **Net** if you want the output to be proportional to the Net value of your measurement (value after taring), or **Gross** if you want the output to be derived from the Gross calibrated value of your measurement. Then press OK.

4

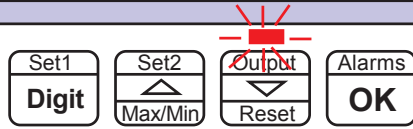

Display now says **Out Lo** and 0% LED will light, Use DIGIT, UP and DOWN buttons to set the display value at which your lowest analogue output signal is to be created. Press OK when done.

5

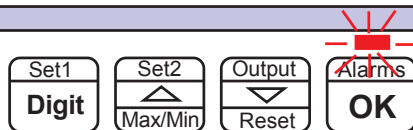

Display now says **Out H**, and 100% LED will light. Use DIGIT, UP, DOWN buttons to set the display value at which your highest analog output signal is to be created. Press OK when done.

6

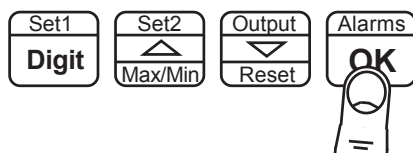

Press to accept



Specifications

Output signal	0-10VDC	-10 to +10V	0-20mA	4-20mA
Drive capacity	> 1K Ohms	> 1K Ohms	< 500 Ohms	< 500 Ohms

Isolation	250 VAC optically isolated from input, logic, excitation, power, alarms and serial communications ports.
Accuracy	$\pm 0.1\%$ of range, ± 10 mV for MAO2 or MAO3, ± 10 μ A for MAO1.
Thermal stability	± 50 ppm/ $^{\circ}$ C stability.
Linearity	$\pm 0.02\%$ of range
Resolution	16-bit D/A. Better than 0.2 mV for 0-10V range, 0.4 μ A for 4-20 mA range.
Scaling	Fully adjustable direct or inverse. Can be derived from Net or Gross value.
Response speed	Derived from displayed value, which is updated 10 times per second. Any filtering applied to the display will be applied to the analog output also.
Linearization	The analog output is derived from the displayed value, so if your display has a non-linear response, and you are using the display's linearizer function, the output will follow the display directly.

Record of Revisions

20 August 2010	Revision 0 version of manual released.
26 November 2010	Revision 2. Software F00.20 released
2 February 2011	Software F00.21 released
28 February 2011	Warranty increased to 3 years and terms added.

Software version F00.21

Revision:3 Dated: 28 February 2011