



LD-UAC

Universal AC Controller



The LD-UAC universal AC indicator and alarm controller is ideal for monitoring and controlling input power, voltage, current or frequency in a wide variety of applications.

This controller has been designed for ease of use, with intuitive, scrolling text prompts that guide you step-by-step through the setup process. The front panel includes 5 buttons, for simple operator interface, and the large 4-digit display ensures that the figures can be easily read from a distance.

Order Codes

LD-UAC	Universal AC Controller
-HV	85–265V AC / 95–370V DC
-LV	15–48V AC / 10–72V DC

Options

-R2	2 x relay outputs
-R4	4 x relay outputs
-A	1 x mA/V analog output

Contents

1 - Specifications	2
2 - Front Panel & Display	3
3 - Wiring	6
4 - Dimensions & Installation	9
5 - Input Setup & Calibration	11
6 - Setpoint Setup	17
7 - Setpoint Direct Access	21
8 - Reset PIN Numbers / View Firmware Version	21

1

SPECIFICATIONS

Input

Input signal Current (0-5A AC) or Voltage (0-300V AC)

Ambient drift 50ppm/°C typical

Accuracy

True RMS Current: 0.05%

True RMS Voltage: 0.1%

Power: 0.1%

Frequency: 0.01Hz

Frequency resolution $\pm 0.001\text{Hz}$

Power

Power supply

HV: 85-265V AC/95-370V DC, or

LV: 15-48V AC/10-72V DC

Relay Output

OPTIONAL

Number of relay outputs None, 2, or 4

Relay output type 5A Form A (3A 240V AC max or 3A 30V DC max)

Analog Output

OPTIONAL

Number of analog outputs None or 1

Analog output type Isolated 16 bit 4-20mA/0-10V

Programming

Front panel buttons Up, Down, P (Prog/Enter), plus 2x Function Buttons for menu access

Display

Display type LED large display, 5 buttons

LED indicators 4 setpoint LED's

Digits 1 row of 4 digits, large 20mm (0.8") size, 7-segment LED

Construction

Casing Panel mount case, 5 buttons

Ingress protection rating IP65 dust/splash proof (face only)

Dimensions (H x W x D)

48 x 96 x 120mm (1.89 x 3.78 x 4.72")

2

FRONT PANEL & DISPLAY

2.1 - Front panel

SPX ■ The SP LED's are used to indicate active setpoints.

F1 This button is used to access the **Input Setup & Calibration** menu (Section 5).

P This button is used to save your settings and advance to the next step in the setup process.

↑ This button is typically used to scroll through options or increase values in the setup menu. Pressing this button from the main display will show the current values for **PWR** (power) **AMP** (current), **PEAK** or **P.F.** (power factor). See 2.4 for more information.

↓ This button is typically used to scroll through options or decrease values in the setup menu. Pressing this button from the main display will show the current values for **ENRG** (energy), **FREQ** (frequency), **VLTS** (voltage) or **VALY** (valley). See 2.4 for more information.

F2 This button is used to access the **Setpoint Setup** menu (Section 6) and the **Setpoint Direct Access** menu (Section 7).

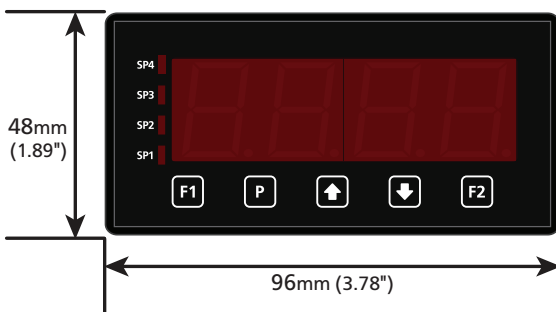

2.2 - Display brightness





To adjust the display brightness, press the **P** and **↑** buttons together from the main display. **BRI** appears and toggles with the current setting. Use the **↑** and **↓** buttons to adjust the LED backlight, and then press **P** to finish.



2.3 - 7 Segment display characters

The 4 digit, 7 segment display is designed for large size and great visibility of numeric characters in normal operating mode. When navigating the setup menus, this table is a useful reference for the mixed-case alphabetic characters.

A	B	C	D	E	F	G
H	I	J	K	L	M	
N	O	P	Q	R	S	T
U	V	W	X	Y	Z	
!	?	/				

2.4 - Up and down button shortcuts

Pressing the  and  buttons from the main operational display allows instant access to a number of values held in the controller's memory. These variables will appear in the order shown in the table below, and will cycle continuously at each press of the  or  button. Press  at any time to return to normal operating mode.

PEAK and **VALY** (valley) may be reset to zero by pressing the  and  buttons at the same time while the variable is being displayed.

Up and Down button shortcuts:

	PWR	Power
	AMP	Current
	PEAK	Max. measured weight since the unit was turned on or reset
	P.F.	Power Factor

	ENRG	Energy (see 3.5 or 6.2F to reset)
	FREQ	Frequency
	VLTS	Voltage
	VALY	(Valley) Min. measured weight since the unit was turned on or reset

3

WIRING

BEFORE YOU BEGIN WIRING, ensure that the power supply is disconnected.

3.1 - Pinouts

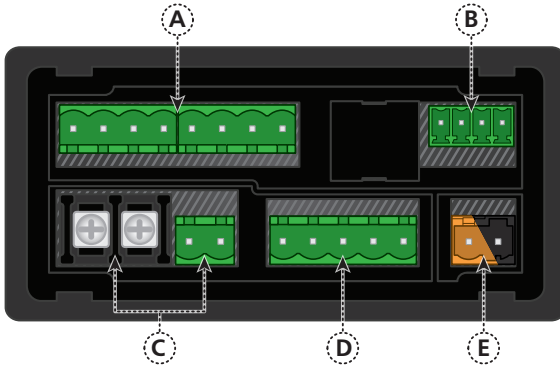

Key

3.1A Relay Output (See 3.3)

3.1B Analog Output (See 3.4)

3.1C Analog Input (See 3.2)

3.1D Function Pins (See 3.5)

3.1E Power Supply (See 3.6)

3.2 - Wire the analog input

See 3.1C

Wire the analog input as required for your application, referring to the diagrams below.

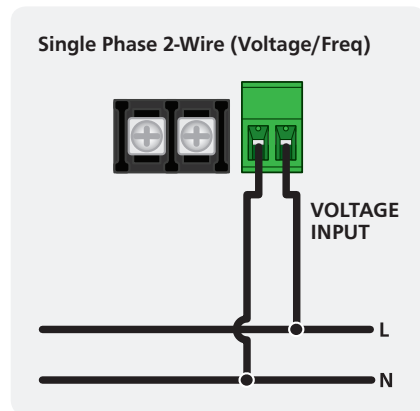
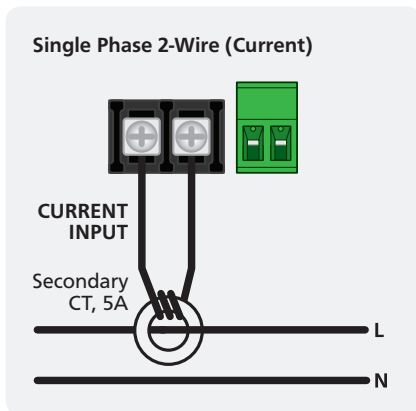

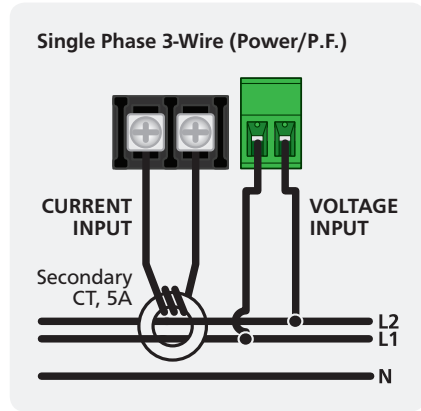
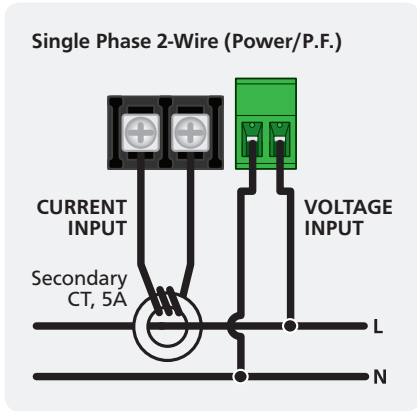

3.3 - Wire the relay outputs

See 3.1A

If your controller has relay outputs fitted, wire them as shown below. Relays can be programmed to operate within the total span range of the controller.

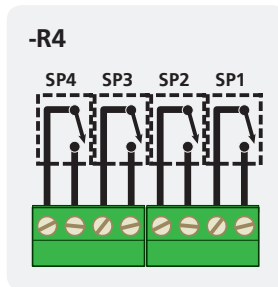
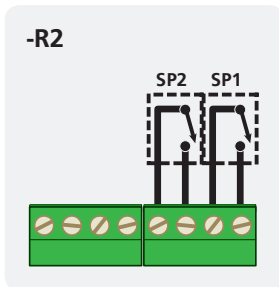

3.4 - Wire the analog output

See 3.1B

If your controller has analog output fitted, wire it as shown for either voltage (0–10V) or current (4–20mA).

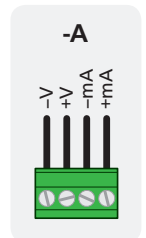

3.5 - Wire the function pins

See 3.1D

Connect external switches to enable a function to be executed when its switch is activated:

Valley Activating this pin will reset the **Valley** value to the current display value

Energy Activating this pin will clear the **Energy** value to zero
(You can also do this using the 'Energy Pulse' feature [see 6.2F])

Test Activating this pin will reset the meter

Peak Activating this pin will reset the **Peak** value to the current display value

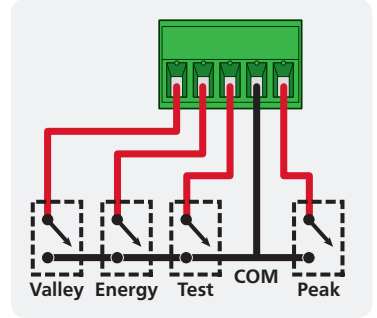

3.6 - Wire the power supply

See 3.1E

DO NOT attempt to wire your controller while the power is on. NEVER connect your low voltage controller to mains power.

Wire your controller for low or high voltage power supply, as show in the diagrams below. Check the label on the unit against the colour of the connector:

- › **Orange** =
High voltage (85–265V AC,
95–370V DC)
- › **Black** =
Low voltage (15–48V AC,
10–72V DC)

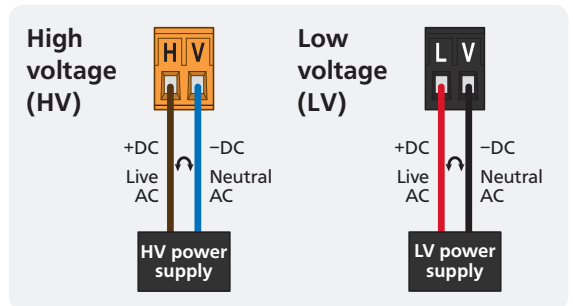

Once you have completed the wiring process it is safe to switch on your power supply. Ensure that your display is functioning before you proceed.

4

DIMENSIONS & INSTALLATION

4.1 - Case dimensions

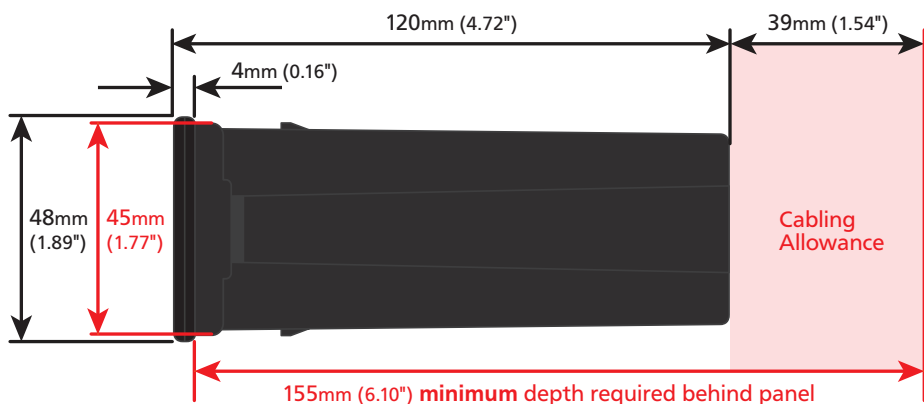
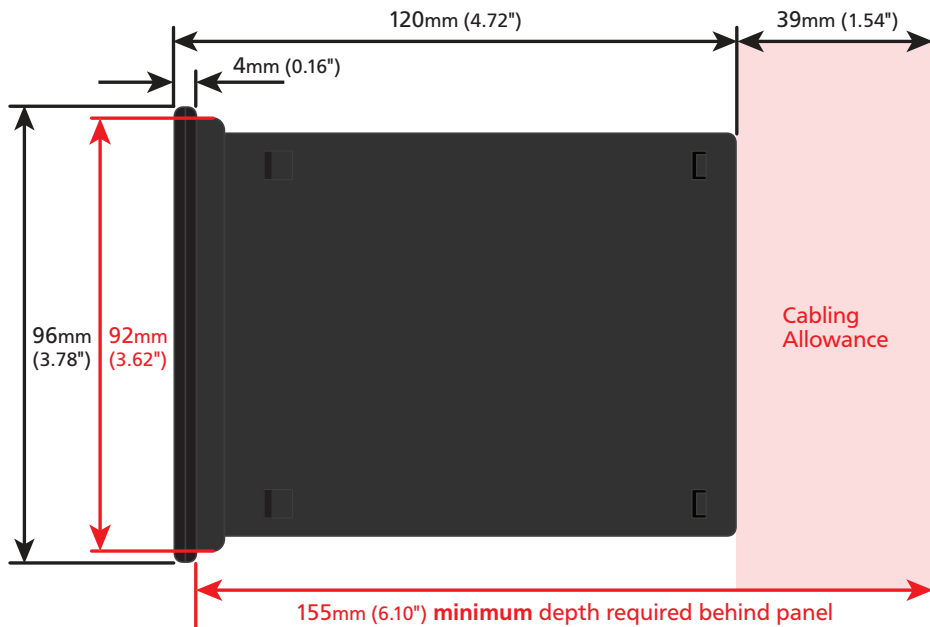

4.2 - Installation instructions

A Prepare the **Panel Cutout** to $92 \times 45\text{mm} \pm 0.5$ ($3.62 \times 1.77" \pm 0.02$), as shown below.

Allow at least 155mm (6.10") depth behind the panel to accommodate the meter body, protruding connectors and cabling.

B Remove the **Mounting Clips** from the meter back.

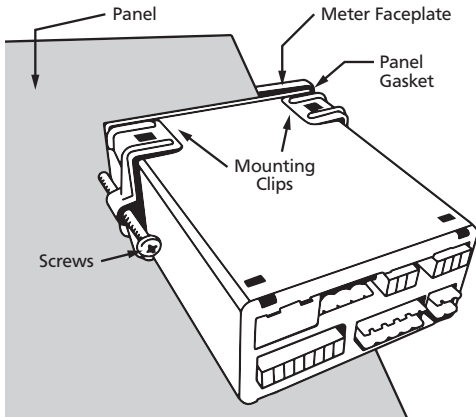

C Slide the **Panel Gasket** over the rear of the unit to the back of the **Meter Faceplate**.

D From the front of the panel, insert the meter into the **Panel Cutout**. Holding the unit in place, engage the **Mounting Clips** so that the tabs snap into place over the notches on the case.

E To achieve a proper seal, tighten the **Screws** evenly until the unit sits firmly against the panel. Do not over-tighten the screws.

Panel Cutout

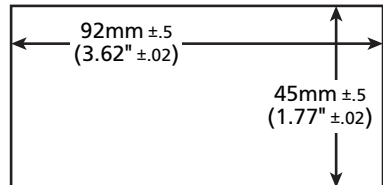

5

INPUT SETUP & CALIBRATION

5.1 - Enter Cal PIN number

A Enter the calibration mode by pressing the **F1** button.

___ ENTER CAL PIN NUMBER scrolls across the display and toggles with **0**. Use the **↑** and **↓** buttons to enter your security code (factory default '1'). Then press **P**. If the correct PIN is entered, setup is started at 5.2.

If an incorrect PIN number is entered, **___ INCORRECT PIN - ACCESS DENIED** scrolls across the display and it returns to normal operating mode.

You will have the opportunity to change your PIN number at the end of this section (5.7). If you have forgotten your PIN number, see Section 8.

5.2 - Input setup

A **___ INPUT SETUP** scrolls across the display and toggles with **SKIP**. Press **P** to skip to 5.3, or use the **↑** and **↓** buttons select an input channel:

AMP (current), **VLTS** (voltage), **PWR** (power) or **FREQ** (frequency), and then press **P** to continue.

➔ If you selected **PWR**, continue to 5.2B now.

➔ Otherwise, skip to 5.2C now.

B **___ RESOLUTION** scrolls across the display. Using the **↑** and **↓** buttons, select: **W**, **KW** or **MW**, and then press **P**.

*Note that certain combinations of **Power Resolution** (5.2B) and **Energy Resolution** (5.3B) may result in a scaling error. See 5.3B for more information.*

C **___ DECIMAL POINT** scrolls across the display and toggles with the current selection. Use the **↑** and **↓** buttons to select an option from the list:

NONE, **0.1**, **0.12** or **0.123**. Then press **P**.

*For **Voltage** inputs, only **NONE** and **0.1** are available.*

*For **Frequency** inputs, only **NONE**, **0.1** and **0.12** are available.*

Averaging (5.2D-E)

Your controller has input signal averaging, optimising stable measurement.

If the change in input exceeds the averaging window value it will not average, ensuring fast response when there are large differences between readings.

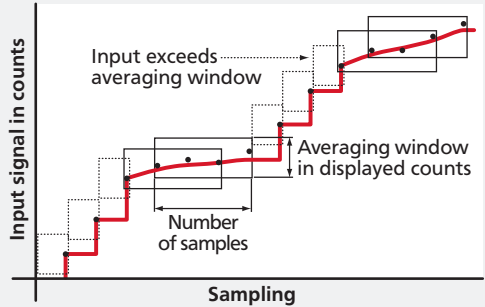

- D** **___ AVE SAMPLES** scrolls across the display and toggles with the currently selected averaging. Using the and buttons, alter the number of input samples that the controller will average, and then press .

Increasing the number of samples will stabilise measurement, but it will also slow down response rates.

- E** **___ AVE WINDOW** scrolls across the display and toggles with the currently selected averaging window value. Using the and buttons, alter the signal averaging window. Then press .



*If your input signal contains large noise spikes, you can increase the size of the averaging window to ensure that these are still averaged. However, increasing the window size too far will reduce the ability of the controller to respond quickly to real changes in input signal. Setting **AVE WINDOW** to 0 will give continuous averaging as per the selected averaging samples.*

- F** **___ INPUT SETUP** scrolls across the display and toggles with **SKIP**. You are now back at 5.2A. To edit different input type, follow the instructions from 5.2A-F again. If you do not wish to edit another input type, press now to skip to 5.3.

5.3 - Energy setup

The energy function allows you to see the total amount of energy that has been used in W/hr, kW/hr or MW/hr.

- A** **___ ENERGY SETUP** scrolls across the display and toggles with **SKIP**. Press to skip to 5.4, or the button and then to **ENTR** (enter) energy setup.



B ___ **RESOLUTION** scrolls across the display and toggles with the currently selected energy resolution. Using the  and  buttons, select: **W**, **KW** or **MW**, and then press .



✔ If the resolution was set successfully, setup will proceed to 5.3C.

❗ ___ **SCALING ERROR - CHANGE ENERGY SETTINGS!**

If you see this message, then the combination of settings that you have selected in *Power Resolution* (5.2B) and *Energy Resolution* (5.3B) will produce values which are too large for the controller to process or display. To correct this, modify the settings in 5.2B or 5.3B.



C ___ **CUTOFF** scrolls across the display and toggles with the currently selected power cutoff value. When the power input value falls below the cutoff value, the energy register will stop accumulating power, and will pause until the input power is greater than or equal to the cutoff value again.



Use the  and  buttons to adjust this value as required, and then press .

D ___ **ROLL OVER** scrolls across the display and toggles with the current setting. If rollover is **ON**, then when the energy value exceeds 9,999, the display will roll to **0** and continue accumulating. If rollover is **OFF**, then the display will read **OVER** in this situation. Use the  and  buttons to turn the rollover feature **OFF** or **ON**, and then press .

*Note that the **ROLL OVER** feature does not produce any output pulse or other indication when it rolls over. (An output pulse can be activated on a setpoint with its data source set to **Energy**. See 6.2F for more information, and to enable this feature.)*

5.4 - Display setup

A ___ **DISPLAY SETUP** scrolls across the display and toggles with **SKIP**. Press  to skip to 5.5, or the  button and then  to **ENTR** (enter) display setup.

B ___ **DISPLAY SOURCE** scrolls across the display and toggles with the current display source. Use the  and  buttons to select: **AMP** (current), **VLTS** (voltage), **PWR** (power), **FREQ** (frequency), **ENRG** (energy) or **P.F.** (power factor). Then press .

5.5 - Calibrate

A **___ CALIBRATE?** scrolls across the display and toggles with **SKIP**. Press **P** to skip to 5.6, or use the **↑** and **↓** buttons to select a channel to calibrate: **AMP** (current) or **VLTS** (voltage), and then press **P**.

- ➔ If you selected **VLTS**, skip to 5.5C now.
- ➔ If you selected **AMP**, continue to 5.5B now.

B **___ CALIBRATION TECHNIQUE** scrolls across the display and toggles with the current selection. Use the **↑** and **↓** buttons to select a calibration method: **AUTO**, **MAN** (manual), or **CT** (current transformer), and press **P** to continue.

- ➔ If you selected **AUTO**, complete steps 5.5C–E now.
- ➔ If you selected **MAN**, complete step 5.5F now.
- ➔ If you selected **CT**, complete steps 5.5G–H now.

***AUTO** (Automatic) - Calibrate by applying high and low input signals.*

***MAN** (Manual) - Calibrate by entering the required display value at full scale.*

***CT** (Current Transformer) - Calibrate by specifying the input and output current for the C.T.*

Auto calibration

C **___ APPLY LOW SCALE INPUT --- ENTER LOW DISPLAY VALUE** scrolls across and toggles with the current selection. Apply the required low input signal. Then, using the **↑** and **↓** buttons, enter your low display value. Press **P** to accept and continue.



D **___ APPLY HIGH SCALE INPUT --- ENTER HIGH DISPLAY VALUE** scrolls across and toggles with the current selection. Apply the required high input signal. Then, using the **↑** and **↓** buttons, enter your high display value, and press **P**.

E If Auto calibration was successful, you will be directed out of the calibration menu to the operational display without viewing any further scrolling messages. (To proceed to step 5.6, you must select **SKIP** at 5.5A.)

If calibration fails, **___ CALIBRATION FAILED** will scroll across the display and you will be directed back to the operational display. The most likely cause of this



error is that the controller could not detect any change in input signal during calibration. Check your signal and connections, and repeat the procedure.



Manual calibration

F **___ ENTER DISPLAY VALUE AT FULL SCALE CURRENT** scrolls across the display and toggles with the current selection. Use the  and  buttons to enter a display value for the full scale current input (typically 5A). Then press .

Manual calibration is now complete. You will be directed back to the operational display. (To proceed to step 5.6, you must select **SKIP** at 5.5A.)

Current Transformer calibration



G **___ ENTER CT INPUT CURRENT** scrolls across the display and toggles with the currently selected CT input value. Adjust this value using the  and  buttons, and then press .



H **___ ENTER CT OUTPUT CURRENT** scrolls across the display and toggles with the currently selected CT output value. Adjust this value using the  and  buttons, and then press .

CT calibration is now complete. You will be directed back to the operational display. (To proceed to step 5.6, you must select **SKIP** at 5.5A.)

5.6 - Analog output setup

*N.B. All new units are calibrated before shipping. Recalibration is **only** necessary if settings are wiped or the unit's accuracy requires verification after a long period of use. e.g. 1 year.*

A **___ ANALOG OUTPUT SETUP** scrolls across the display and toggles with **SKIP**. If your controller does not have analog output installed, (or you do not wish to configure your analog output now), press  to skip to 5.7. Otherwise, press the  button and then  to **ENTER** analog output setup.

B **___ DATA SOURCE** scrolls across the display and toggles with the current analog output data source. Use the  and  buttons to select an option: **AMP** (current), **VLTS** (voltage), **PWR** (power), **FREQ** (frequency), **ENRG** (energy), or **P.F.**

(power factor). Then press **P**.

- C** **___ LOW SCALE VALUE** scrolls across the display and toggles with the currently selected low scale display value. Use the **↑** and **↓** buttons to enter your cal low position, and then press **P**.
- D** **___ HIGH SCALE VALUE** scrolls across the display and toggles with the currently selected high scale display value. Use the **↑** and **↓** buttons to enter your cal high position, and then press **P**.
- E** **___ CALIBRATE ANALOG O/P?** scrolls across the display and toggles with **NO**. Use the **↑** and **↓** buttons to select **YES** or **NO**, and then press **P**.

Factory analog output calibration is precisely set before shipping this instrument, and should not be adjusted unless advised by the manufacturer.

- ➔ If you selected **YES**, connect a mA or volt meter across the analog output connector (see 3.1B), and then continue to 5.6F.
- ➔ If you selected **NO**, the display will return to normal operating mode.

- F** **___ CAL LOW ANALOG O/P** scrolls across and toggles with a calibration number shown in internal units (around -16000). Press the **↑** and **↓** buttons until your multimeter displays your target low output (e.g. 4mA), then press **P**.
- G** **___ CAL HIGH ANALOG OUTPUT** scrolls across and toggles with a calibration number shown in internal units (around 30000). Press the **↑** and **↓** buttons until your multimeter displays your target high output, then press **P**.

Analog output calibration is now complete. The display will return to normal operating mode.

5.7 - Edit Cal PIN number

- A** **___ EDIT CAL PIN NUMBER** scrolls across the display and toggles with **SKIP**. Press **P** to skip and return to the operational display, or the **↑** button and then **P** to **ENTER** and change your PIN number.
- B** **___ ENTER NEW CAL PIN NUMBER** scrolls across the display and toggles with the current PIN (default 1). Using the **↑** and **↓** buttons, enter your new Calibration PIN number. Then press **P** to exit to the operational display.

6

SETPOINT SETUP

The software in your controller will allow you to configure up to 4 setpoints, however full functionality is only supported when relay output hardware installed.

(Setpoints with no corresponding relay output hardware may be used as simple LED indicators, if desired. In this case, features requiring relay output functionality will continue to appear in the setup menu, but will be ignored by the controller.)

6.1 - Enter Setpoint PIN number

- A Enter setpoint setup mode by pressing and holding the **F2** button for 3 seconds. **___ ENTER SP PIN NUMBER** scrolls across the display and toggles with **0**. Use the **↑** and **↓** buttons to enter your security code (factory default '1'). Then press **P**. If the correct PIN is entered, setup is started at 6.2. If an incorrect PIN number is entered, **___ INCORRECT PIN NUMBER - ACCESS DENIED** scrolls across the display and it returns to normal operating mode.

You will have the opportunity to change your PIN number at the end of this section (6.3). If you have forgotten your PIN number, see Section 8.



6.2 - Setpoint setup

- A **___ EDIT SETPOINT** scrolls across the display and toggles with **SKIP**. Press **P** now to skip to 6.3, or use the **↑** and **↓** buttons to select a setpoint to edit, and then press **P**.
- B **___ SP VALUE** scrolls across the display and toggles with the current value for the selected setpoint. Using the **↑** and **↓** buttons, adjust the display value at which the selected setpoint will activate, and then press **P**.



C The step that you proceed to now will depend on which setpoint you are editing (selected in 6.2A):

- ➔ If you are currently editing **SP 1**, skip to 6.2E now.
- ➔ If you are currently editing **SP 2–4**, continue to 6.2D now.

D **___ TRACK SP1** scrolls across the display and toggles with the tracking setting for the selected setpoint. A setpoint with **TRACK SP1** enabled will inherit the *SP Source* (6.2E) of **SP 1**, and track the *SP Value* of **SP 1**. (The setpoint value of the tracking setpoint will effectively become an offset value.)

Using the  and  buttons, turn tracking **OFF** or **ON**, and then press .



- ➔ If you selected **ON**, then the step that you proceed to now will depend on the *SP Source* (6.2E) that is currently set for **SP 1**:
 - If the *SP Source* for **SP 1** is set to **ENRG**, skip to 6.2F now.
 - Otherwise, skip to 6.2H now.
- ➔ If you selected **OFF**, continue to 6.2E now.

E **___ SP SOURCE** scrolls across the display and toggles with the activation source for the selected setpoint. Use the  and  buttons to select from the following options: **AMP** (current), **VLTS** (voltage), **PWR** (power), **FREQ** (frequency), **ENRG** (energy), or **P.F.** (power factor). Then press .



- ➔ If you selected **ENRG**, continue to 6.2F now.
- ➔ Otherwise, skip to 6.2H now.

Energy Setpoints

*(For setpoints with **SP SOURCE** set to **ENRG**, or setpoints that inherit **ENRG** data source from tracking **SP 1**.)*



F **___ ENERGY PULSE** scrolls across the display and toggles with the current setting. If this feature is enabled, then when the setpoint is activated it will output a pulse and then clear the **Energy** value to zero. Using the  and  buttons, turn the energy pulse feature **OFF** or **ON**, and then press .

- ➔ If you selected **ON**, continue to 6.2G now.
- ➔ Otherwise, skip to 6.2H now.

- G** ___ **PULSE WIDTH** scrolls across the display and toggles with the current pulse width. Use the  and  buttons to adjust the pulse width from **0.1** to **10** seconds, and then press .



➔ Please skip steps 6.2H–K, and proceed to 6.2L now.

Current, Voltage, Power, Frequency, or Power Factor Setpoints

- H** ___ **SP ACTIVATION** scrolls across the display and toggles with the current activation for the selected setpoint. Using the  and  buttons, select the relay activation to operate **ABVE** (above) or **BLW** (below) the setpoint value, and then press .

ABVE: Relay turns on above the setpoint value and off below it.

BLW: Relay turns on below the setpoint value and off above it.

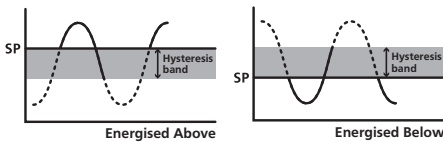

- I** ___ **SP TYPE** scrolls across the display and toggles with the current setting for the selected setpoint. Using the  and  buttons, select either **ALM** (alarm) or **CTRL** (control), and then press .

ALM - SETPOINT VALUE controls setpoint activation point. **HYSTERESIS VALUE** controls setpoint deactivation point.



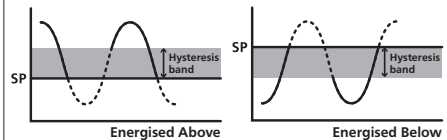





CTRL - SETPOINT VALUE controls setpoint deactivation point. **HYSTERESIS VALUE** controls setpoint reactivation point.





- J** ___ **HYSTERESIS VALUE** scrolls across the display and toggles with the hysteresis value for the selected setpoint. Use the  and  buttons to adjust this value if required, and then press .

The **HYSTERESIS VALUE** defines the separation band between setpoint activation and deactivation, and will operate as per the **SP TYPE** setting selected in 6.2I.



- K** ___ **MAKE DELAY** scrolls across the display and toggles with the current make delay time for the selected setpoint. This is the time delay between setpoint activation, and when the relay turns on. Adjust this value in 0.1 second increments using the  and  buttons, and then press .



- L** ___ **USER ACCESS?** scrolls across the display and toggles with the direct access permission setting for the selected setpoint. Use the  and  to select either **OFF** or **ON**, and then press .

When enabled, this option allows the selected setpoint's value to be edited directly after pressing the  button, without needing to enter a PIN number or go through all of the other options. Each setpoint can individually have this option enabled or disabled. See Section 7.

- M** ___ **EDIT SETPOINT** scrolls across the display and toggles with **SKIP**. You are now back at 6.2A. To edit another setpoint, follow the instructions from 6.2A–M again. If you do not wish to edit another setpoint, press  now to skip to 6.3.

6.3 - Edit SP PIN number

- A** ___ **EDIT SP PIN NUMBER** scrolls across the display and toggles with **SKIP**. Press  to skip and return to the operational display, or the  button and then  to **ENTER** and change your PIN number.

- B** ___ **ENTER NEW SP PIN NUMBER** scrolls across the display and toggles with the current PIN (default 1). Using the  and  buttons, enter your new SP PIN number. Then press  to exit to the operational display.

7

SETPOINT DIRECT ACCESS

If none of the setpoints have their direct access option enabled then this feature will be disabled and the **F2** button will not respond to a short button press. (See 6.2L.)

- A Begin by pressing the **F2** button for less than 3 seconds.
- B The name of the first access-enabled setpoint will appear on the display and toggle with the current value for that setpoint. Using the **↑** and **↓** buttons, adjust the selected value. Then press **P** to accept and continue.
- C The name of the next access-enabled setpoint will appear on the display, along with its setpoint value. Repeat step 7B. The direct access menu will proceed through all access-enabled setpoints in this fashion. Pressing **P** for the last enabled setpoint will exit and return to the operational display.

8

RESET PIN NUMBERS / VIEW FIRMWARE VERSION

If you have forgotten your PIN number(s), follow the procedure below to reset both the Calibration and Setpoint PINs to their factory default of 1.

This procedure will also allow you to view the current software installed on your device, which may be required for support purposes.

- A Press **↑**, **↓** and **P** at the same time. (This key combination can be difficult to execute and you may need several tries to get it right.)
- B A message will appear on the display, with details of the unit's current software configuration (Product name, Firmware Version, and Macro Version). At the end, you will see **___ ALL PIN NUMBERS RESET TO 1.**
- C Both the Cal PIN number and the SP PIN number have now been reset to '1'. You can change this, if required, by following the instructions in 5.7 (for Cal) and 6.3 (for SP), using '1' to enter each menu initially.



Define Instruments

New Zealand (Head Office)

 10B Vega Place, Rosedale,
Auckland 0632, New Zealand
PO Box 245 Westpark Village,
Auckland 0661, New Zealand

Ph: +64 (9) 835 1550

Fax: +64 (9) 835 1250

 sales@defineinstruments.co.nz

www.defineinstruments.co.nz

United States (Dallas, TX)

Ph: (214) 926 4950

 sales@defineinstruments.com

www.defineinstruments.com
