



C-LB45-A FUEL METER ASSEMBLY INSTALLATION & OPERATION MANUAL

Version 1.4



Instrumart
35 GREEN MOUNTAIN DR • S. BURLINGTON • VERMONT • 05403 • USA
888-FLOW-888 • www.instrumart.com/tactical-meters

CONTENTS

1.	Index of Figures	2
2.	Notes, Warnings & Cautions	3
3.	Introduction	6
4.	Operating Principle of Meter	8
5.	Preparation for Use and Installation of Meter	8
6.	Installation Instructions for Meter	9
7.	Operational Start Up: Turbine Flow Meter	10
8.	Meter Specifications	13
	A. Materials of Construction	13
	B. Operating Limitations	14
9.	Maintenance and Repair of Meter	15
	A. Disassembly	16
	B. Installation of the New Kit	16
10.	Introduction of Monitor	17
11.	Specifications for Monitor	19
12.	Operating the Monitor	20
	A. Advanced Programming Mode	20
	B. Programming Using Pulse Output Turbine Flow Meters	21
13.	Battery Replacement	26
14.	Monitor Enclosure Installation	27
	A. Installation	27
	B. Maintenance	28
15.	Programming Menu Diagram	29
16.	Troubleshooting the Monitor	30
17.	General Notes on Scaling	31
	Appendix A: Troubleshooting Guide	33
	Appendix B: Replacement Parts	34
	Appendix C: Temperature Compensation Tables	37
	Appendix D: Meter Kit Diagrams	42

NOTICE: Instrumart reserves the right to make any changes or improvements to the product described in this manual at any time without notice.

1. INDEX OF FIGURES

Fig. 1	Photograph of main meter assembly	6
Fig. 2	Photograph of comparative pipe sizes	7
Fig. 3	Schematic illustration of electric signal generated by rotor movement ...	8
Fig. 4	Meter installation utilizing a bypass line	10
Fig. 5	Meter installation without utilizing a bypass line	11
Fig. 6	Location of reset button	12
Fig. 7	Typical cross-section of turbine flow meter	13
Fig. 8	Typical turbine flow meter components	15
Fig. 9	Flow meter display	18
Fig. 10	Front panel	20
Fig. 11	Explosion proof circuit board layout (battery powered)	25
Fig. 12	Explosion proof enclosure	26
Fig. 13	Programming menu	29
Fig. 14	Typical turbine meter components	34
Fig. 15	Kit, fuel pumping 2"	42
Fig. 16	Kit, fuel pumping 4"	43
Fig. 17	Kit, fuel pumping 6"	44
Fig. 18	Monitor	45
Fig. 19	Monitor, cover removed	46

2. NOTES, WARNINGS & CAUTIONS:

Notes, Warnings and Cautions that appear in this manual call special attention to instructions that affect the safe installation, function, and use of this product. Any use of this product in a manner not specified by the manufacturer may be dangerous and will void the manufacturer's warranty. Whenever these notes appear please refer to accompanying documentation.

NOTE:

1. During transportation the displayed totalization may be affected. Displayed total should be written down if you wish to keep this data. The meter should then be reset upon arrival at its destination. *Pages 8,9*
2. All control valves must be located downstream of the flow meter. This is true with any restriction in the flow line that may cause the liquid to flash. If necessary, air eliminators should be installed to ensure that the meter is not incorrectly measuring entrained air or gas. *Page 9*
3. The covers of these meters should not be removed except by authorized personnel. The programming for this meter should not be changed except by authorized personnel. Reprogramming the unit can affect the accuracy. *Page 11*
4. It may be necessary to use the temperature compensation tables in Appendix C to maintain accurate flow measurements for fuels at low temperatures. *Page 11*
5. The accuracy of the meter may be affected by high viscosity fluids. This includes diesel fuels at low temperatures. Please refer to operating instructions for accuracy information and Appendix C for temperature compensation tables. *Page 14*
6. Do not interchange repair kit components as this will void the calibration data. *Page 15*
7. Before reassembly, note that an arrow is cast or engraved on each component. The arrow indicates the direction of flow. The meter must be reassembled with arrowheads pointed in the direction of the fluid flow. Each rotor support has one of its blades notched. This notch is to be oriented in the up position on both rotor supports. The side of the meter with the magnetic pickup signifies the up position. This is the position that the repair kit was calibrated, and this is the position that it is to be used in to ensure meter accuracy. See Figure 6 for proper alignment and orientation of the repair kit. *Page 16*
8. The electronics will need to be re-programmed to accept the new calibration of the repair kit if a new kit was installed. Refer to the programming section of the manual for instructions. *Page 16*
9. The meter connection size and the bore size are different. For example, many of the 1" NPT turbines have bore sizes that range from 3/8" up 1". Be sure to use the correct bore size or the meter could report incorrect flows and totals. *Page 20*
10. If flow rate is the only measurement of interest, skip to KFAC UNT to complete the programming process. *Page 20*

11. Password will allow users to reset totals. *Page 22*
12. Entering a password in the Password screen and leaving the password blank in the RST PSWD screen would allow for total resets (not requiring password) and restrict programming modification. *Page 23*
13. When installing device be sure to check instrument dimensions to avoid interference with clamping ring on glass lens and the cover on standard units. *Page 26*

WARNING:

1. Make sure that fluid flow has been shut off and pressure in the line released before attempting to install the meter in an existing system. *Page 10*
2. Pressure in excess of allowable rating may cause the housing to burst and cause serious personal injury. *Page 14*
3. Do not open enclosure unless the area is known to be free of hazards. Failure to make the area safe before opening the enclosure can result in a hazardous situation with a potential for injury. *Pages 17, 25*
4. Electrical power must be "OFF" before and during installation and maintenance. *Page 26*
5. Always disconnect primary power source before opening enclosure for inspection or service. *Page 27*

CAUTION:

1. The liquid being measured should be free of any large particles that may obstruct rotation of the rotor. If particles are present, a mesh strainer should be installed upstream before operation of the flow meter (See Table 1). *Page 9*
2. Damage can be caused by striking an empty meter with a high velocity flow stream. *Page 9*
3. Do not locate the flow meter or connection cable close to electric motors, transformers, sparking devices, high voltage lines, or place connecting cable in conduit with wires furnishing power for such devices. These meters are being used to measure highly flammable fluids. Ignition sources could cause these fuels to explode or burn causing serious injury or death. In addition these devices can induce false signals in the flow meter coil or cable, causing the meter to read inaccurately. *Page 9*
4. High velocity air or gas may damage the internal components of the meter. *Page 10*
5. The meter should not be subjected to temperatures above +140° F (60° C), or below -40° F (-40° C) or the freezing point of the metered liquid. High temperatures will damage the magnetic pick-up and/or the electronics while lower temperatures will limit the rotation of the rotor and possibly damage the electronic display(s). *Page 14*

6. Excess air pressure may damage the rotor and bearings by causing the rotor to spin too quickly. *Page 16*
7. All unused conduit openings must be plugged. Plugs must be a minimum of 1/8" thick and engage a minimum of 5 full threads. *Page 26*
8. Use care to prevent dirt, grit or other foreign material from lodging on threads. If any such material settles on these threads, clean them with Kerosene or Stoddard solvent, then re-lubricate with thread lubricant. *Page 26*
9. Always reassemble rotor supports, rotor, and meter body with flow arrows pointing in the same direction. *Page 33*

The Model C-LB45-A turbine flow meter is designed to withstand the rigorous demands of the most remote flow measurement applications. The Model C-LB45-A flow meter maintains measurement accuracy and mechanical integrity in a military expeditionary environment from the Arctic to the desert or tropical regions of the world. This flow meter has been fitted with a protective roll cage and cam lock fittings for service as a tactical fuels flow meter with $\pm 0.5\%$ volumetric accuracy. This meter is intended for use with Jet A, Jet A1, JP 5, JP8, DF1, DF2, and DF4.

The tactical fuels flow meter comes in three sizes for use with 2", 4" and 6" fuel lines.

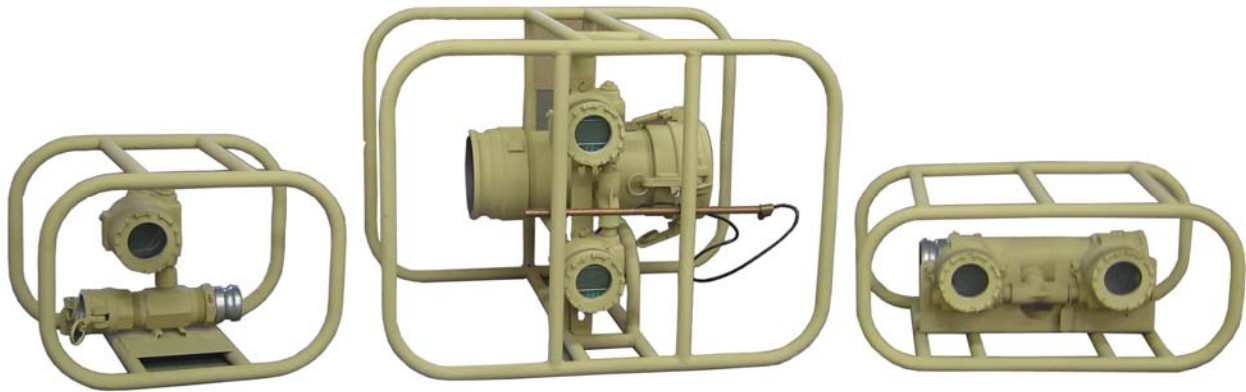

Fig.1 Photograph of main meter assembly

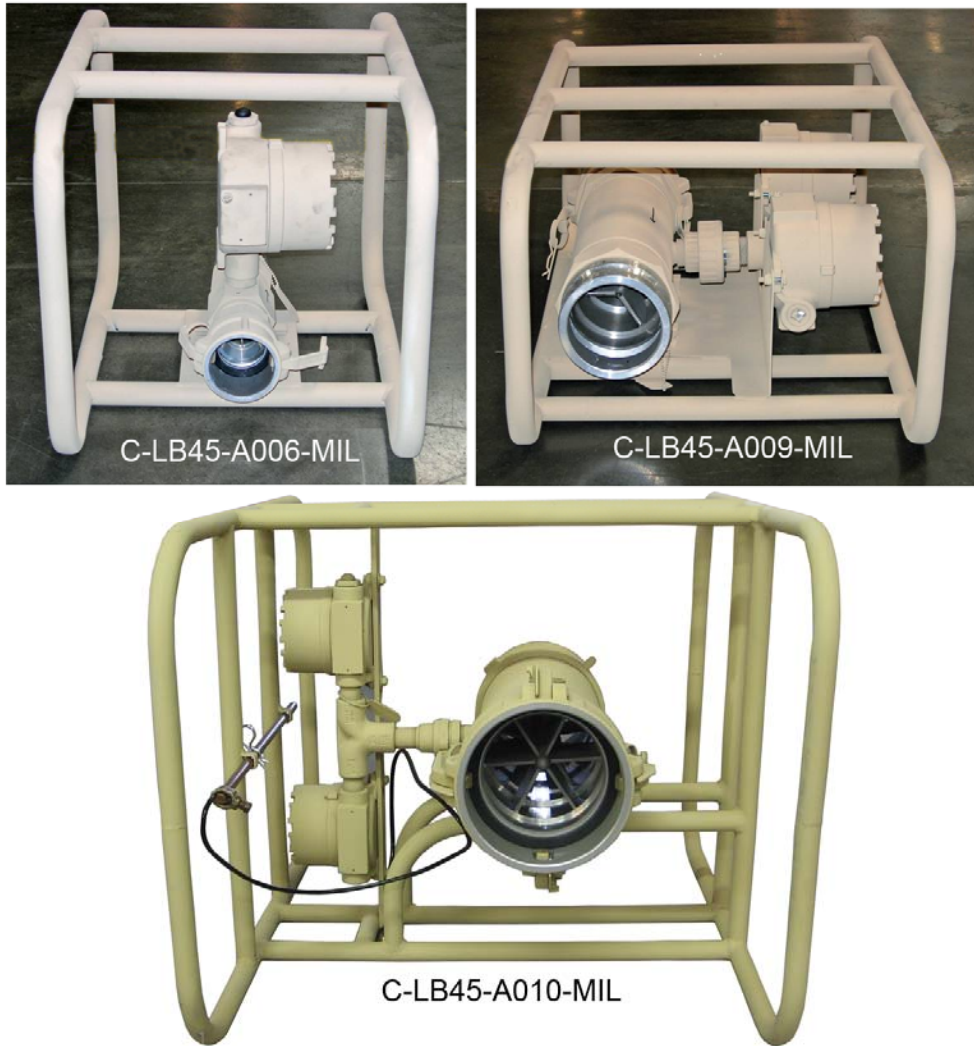

Fig. 2 Photograph of comparative pipe sizes

C-LB45-A006-MIL (2" cam lock fittings for 5 to 250 GPM) This unit weighs 19 pounds and is 20x14x14 inches (LxWxH). This unit is equipped with a single display and a reset key.

C-LB45-A009-MIL (4" cam lock fittings for 50 to 900 GPM) This unit weighs 43 pounds and is 26.5x17x12 inches (LxWxH). This unit is equipped with a dual display and a single reset key (one display cannot be reset).

C-LB45-A010-MIL (6" cam lock fittings for 50 to 900 GPM) This unit weighs 73 pounds and is 23x26.5x31.5 inches (LxWxH). This unit is equipped with a dual display and a single reset key (one display cannot be reset).

The tactical fuels flow meter is powered by a single "D" cell Lithium battery. A standard alkaline battery can be used to power the meter as long as the battery is kept above minus twenty two degrees Farenheit (-22°F). This is for temporary use only as an alkaline battery will last only a few months depending on environmental conditions.

Only four tools are required to service the C-LB45-A: a small Phillips head screwdriver, a small flat blade screwdriver, a pair of pliers, and a 7/16" wrench.

As the tactical fuels flow meter was designed to be field transportable, it requires very little in the way of packaging. A roll cage protects the unit from most damage that could occur from being dropped. It is important to protect the electronic monitor(s) from being impacted from either the top or the sides.

NOTE: During transportation the displayed totalization may be affected. Displayed total should be written down if you wish to keep this data. The meter should then be reset upon arrival at its destination.

4. OPERATING PRINCIPLE OF METER:

Fluid entering the meter passes through the inlet flow straightener which reduces its turbulent flow pattern and improves the fluid's velocity profile. Fluid then passes through the turbine blades causing them to rotate at a speed proportional to the fluid velocity. As each blade passes through the magnetic field created at the base of the pickoff transducer, AC voltage (pulse) is generated in the pickup coil (see Figure 3). These impulses produce an output frequency proportional to the volumetric flow through the meter. The output frequency is then used to indicate flow rate and/or totalization of fluid passing through the turbine flow meter on the display(s).

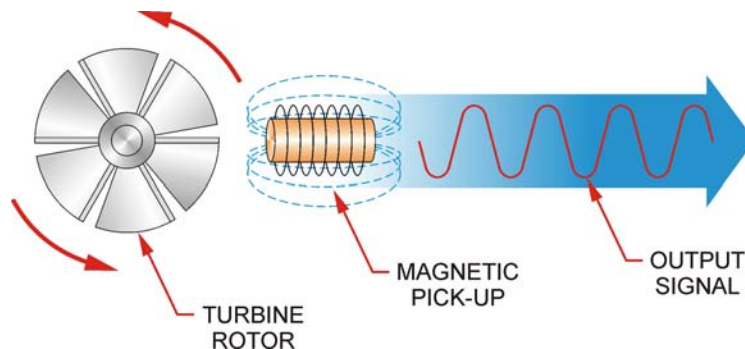

Fig. 3 Schematic illustration of electric signal generated by rotor movement.

5. PREPARATION FOR USE AND INSTALLATION OF METER:

The C-LB45-A series flow meter is not equipped with an "on/off" button. This meter is always on as long as the battery is installed. If the unit has been in storage and the display(s) are not working, please check the battery. A visual check of the meter is all that is required to verify if there has been any shipping damage. Prior to installation, the flow meter should be checked internally for foreign material and to ensure the turbine rotor spins freely. Fuel hoses should also be checked and cleared of all debris before being attached to flow meter.

NOTE: During transportation the displayed totalization may be affected. Displayed total should be written down if you wish to keep this data. The meter should then be reset upon arrival at its destination.

CAUTION: The liquid being measured should be free of any large particles that may obstruct rotation of the rotor. If particles are present, a mesh strainer should be installed upstream before operation of the flow meter. (See Table 1)

TABLE 1

PART NUMBER	STRAINER MESH	CLEARANCE	FILTER SIZE
C-LB45-A006-MIL	20 X 20	.0340	.86mm
C-LB45-A009-MIL	10 X 10	.0650	1.6mm
C-LB45-A010-MIL	4 X 4	.1875	4.8mm

6. INSTALLATION INSTRUCTIONS FOR METER:

The flow meter must be installed with the female cam lock on the upstream side of the fluid flow. Though the meter is designed to function in any position, it is recommended, where possible, to install horizontally (as shown on front cover).

NOTE: All control valves must be located downstream of the flow meter. This is true with any restriction in the flow line that may cause the liquid to flash. If necessary, air eliminators should be installed to ensure that the meter is not incorrectly measuring entrained air or gas.

CAUTION: Damage can be caused by striking an empty meter with a high velocity flow stream.

It is recommended that a minimum length of straight hose, equal to ten (10) hose diameters of straight hose, be installed on the up-stream (female cam lock) side and five (5) diameters on the downstream (male cam lock) side of the flow meter. Otherwise meter accuracy may be affected. Piping should be the same size as the meter bore or threaded port size. Use of reducing or expansion couplers, tees, and wyes is not recommended due to the possibility of decreased accuracy.

CAUTION: Do not locate the flow meter or connection cable close to electric motors, transformers, sparking devices, high voltage lines, or place connecting cable in conduit with wires furnishing power for such devices. These meters are being used to measure highly flammable fluids. Ignition sources could cause these fuels to explode or burn causing serious injury or death. In addition these devices can induce false signals in the flow meter coil or cable, causing the meter to read inaccurately.

7. OPERATIONAL START UP: TURBINE FLOW METER

The following steps should be followed when installing and starting the meter.

WARNING: Make sure that fluid flow has been shut off and pressure in the line released before attempting to install the meter in an existing system.

CAUTION: High velocity air or gas may damage the internal components of the meter.

1. Open upstream isolating valve slowly to eliminate hydraulic shock while charging the meter with the liquid. Open the valve to full open.
2. Open downstream isolating valve to permit meter to operate.
3. Adjust the downstream valve to provide the required flow rate through the meter. Note: The downstream valve may be used as a control valve. (see *figs. 4 & 5*)

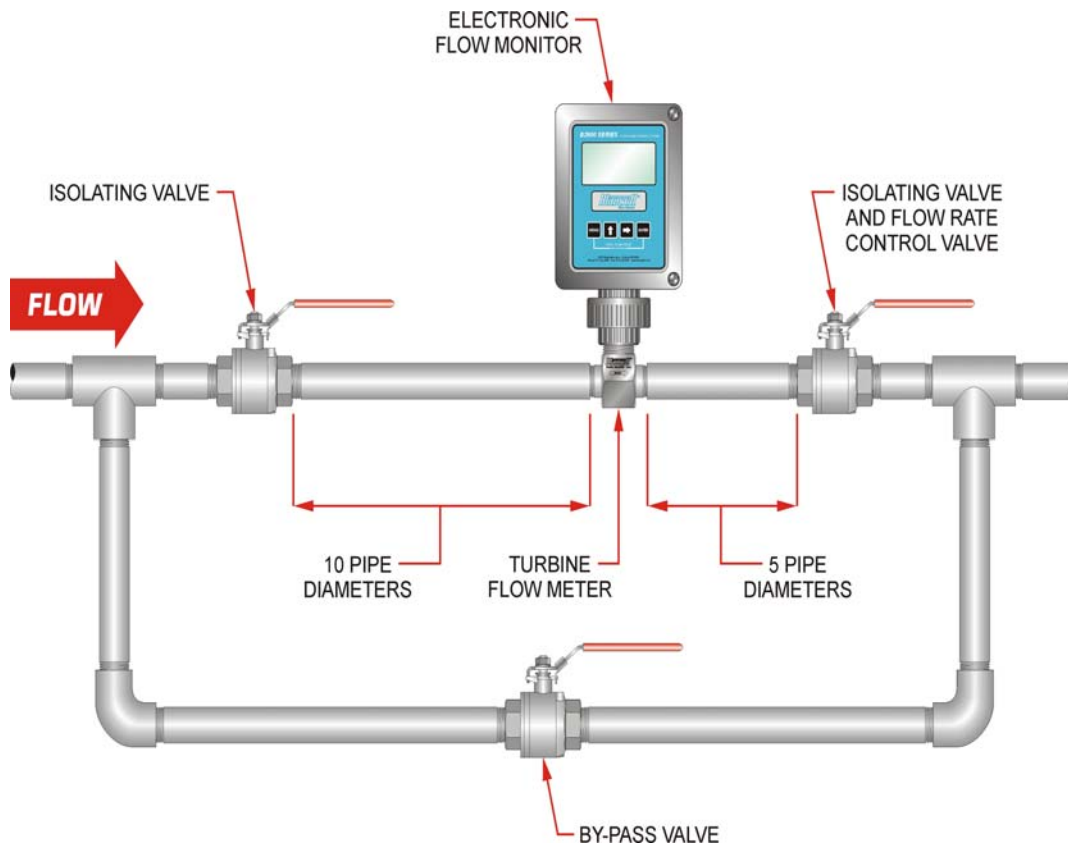

Fig. 4 Meter installation utilizing a bypass line

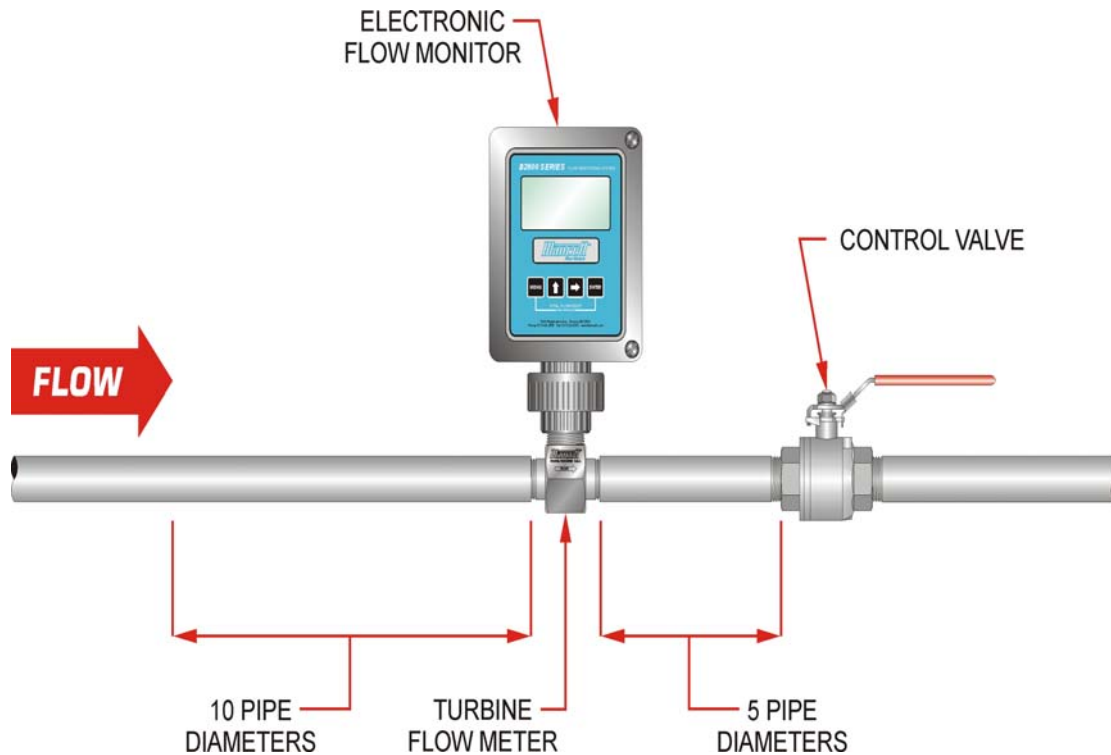
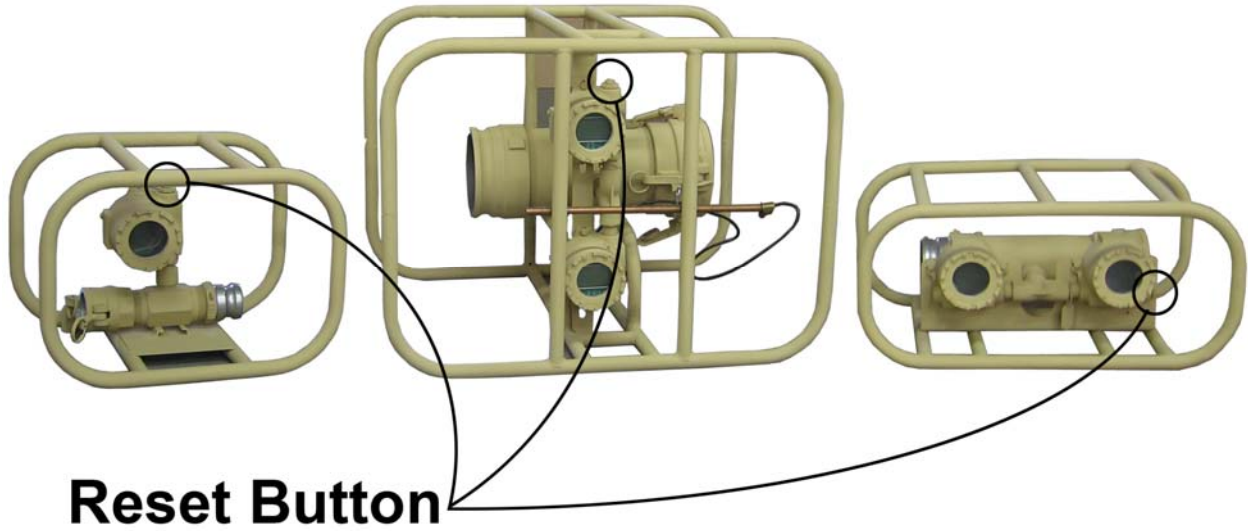

Fig. 5 Meter installation without utilizing a bypass line

These flow meters include a reset button to reset the total displayed on the monitor. The four- and six-inch models include an additional monitor that is not normally reset. This monitor is designed to keep track of the total fuel usage. Please refer to transportation notes for important information regarding the totalized value. To reset the totalized display of the flow meter press the reset button. (see fig. 6)

NOTE: The covers of these meters should not be removed except by authorized personnel. The programming for this meter should not be changed except by authorized personnel. Reprogramming the unit can affect the accuracy.

NOTE: It may be necessary to use the temperature compensation tables in Appendix C to maintain accurate flow measurements for fuels at low temperatures.



Reset Button

Fig. 6 Location of reset button

If problems arise with the flow meter and monitor, consult Appendix A (Trouble Shooting Guide). If further problems arise, consult Instrumart. If the internal components of the turbine flow meter are damaged beyond repair, repair kits are available. Information pertaining to the turbine meter repair kits are referenced in Appendix B.

8. METER SPECIFICATIONS:

A. MATERIALS of CONSTRUCTION:

Body: 316 Stainless Steel

Rotor: CD4MCU Stainless Steel

Rotor Support and Bearings: 316 Stainless Steel

Rotor Shaft: Tungsten Carbide

Roll Cage: Carbon Steel

Display: Aluminum and Glass

Cam Locks: Aluminum with Buna-N seals

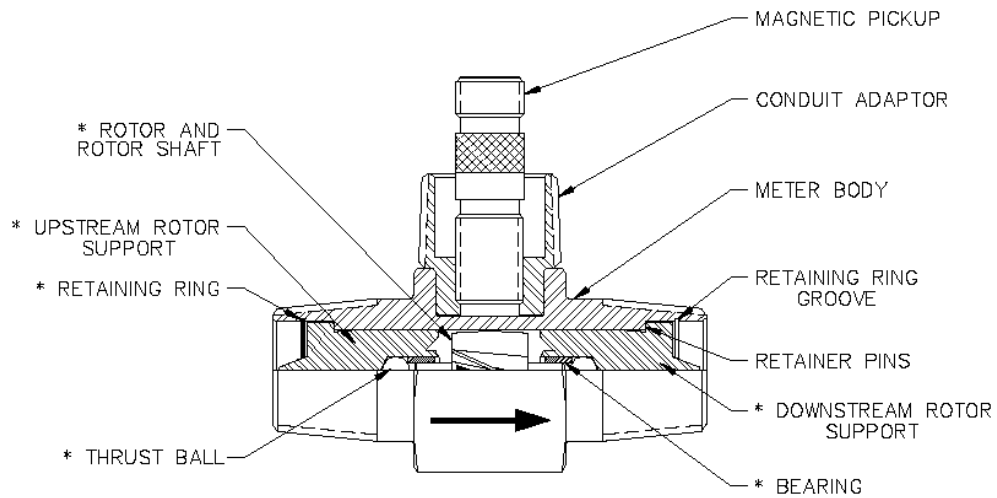

NOTE: * INDICATES PARTS
CONTAINED IN REPAIR KITS

Fig. 7 Typical cross-section of turbine flow meter.

B. OPERATING LIMITATIONS:

Temperature: -40° F to +140° F (-40° C to +60° C)

CAUTION: The meter should not be subjected to temperatures above +140° F (60° C), or below -40° F (-40° C) or the freezing point of the metered liquid. High temperatures will damage the magnetic pick-up and/or the electronics while lower temperatures will limit the rotation of the rotor and possibly damage the electronic display(s).

NOTE: The accuracy of the meter may be affected by high viscosity fluids. This includes diesel fuels at low temperatures. Please refer to operating instructions for accuracy information and Appendix C for temperature compensation tables.

Pressure: The following meters have a maximum operating pressure rating of:

C-LB45-A006-MIL	150 psi
C-LB45-A009-MIL	150 psi
C-LB45-A010-MIL	150 psi

WARNING: Pressure in excess of allowable rating may cause the housing to burst and cause serious personal injury.

Accuracy: +/- 0.5% of reading.

NOTE: The accuracy of the meter may be affected by high viscosity fluids. This includes diesel fuels at low temperatures. Please refer to operating instructions for accuracy information and Appendix C for temperature compensation tables.

Calibration: Water (NIST Traceable Calibration)

Corrosion: All FloCat C-LB45-A turbine meters are constructed of stainless steel and tungsten carbide. This meter is approved for use with water and all commercial and military aviation turbine fuels and diesel petroleum. The operator must ensure that the operating fluid is compatible with these materials. Incompatible fluids can cause deterioration of internal components and cause a reduction in meter accuracy.

**Pulsation and
Vibration:**

Severe pulsation and mechanical vibration will affect accuracy, and shorten the life of the meter.

Filtration: If small particles are present in the fluid, Instrumart recommends that a strainer be installed upstream of the meter (see Table 1 for filtration recommendations). Abrasive particles will shorten the life of the meter.

9. MAINTENANCE AND REPAIR OF METER:

The Model C-LB45-A Turbine Meter Repair Kit is designed for easy field service of a damaged flow meter, rather than replacing the entire flow meter (see Appendix B for repair kit information). Repair parts are factory calibrated to ensure accuracy throughout the entire flow range. Each kit contains all of the internal components of the turbine flow meter and includes the calibrated K-factors (calibrated number of pulses generated per gallon of fluid) which are used to recalibrate the flow monitor(s) to provide accurate output data. All components are stamped with an arrow to show the flow direction. Be sure that the arrows all face in the direction of the flow when re-assembling the meter.

NOTE: Do not interchange repair kit components as this will void the calibration data.

The meter should be visually inspected for build-up of “sludge” or other foreign material on or around the turbine blades, shaft and rotor supports. If turbine blades do not spin freely, or the accuracy of the meter is affected, the meter should be disassembled and cleaned or repaired. The meter can be cleaned with mineral spirits and a brass wire brush.

Frequent inspection should be made. A schedule for maintenance checks should be determined by the environment and frequency of use. It is recommended that it should be at least once a year. If an accuracy issue is suspected the meter should be cleaned or refurbished with a repair kit. The kit replaces all internal components of the meter with factory calibrated components.

Testing consists of running a known amount of fuel through the meter and verifying that the accuracy is within tolerance.

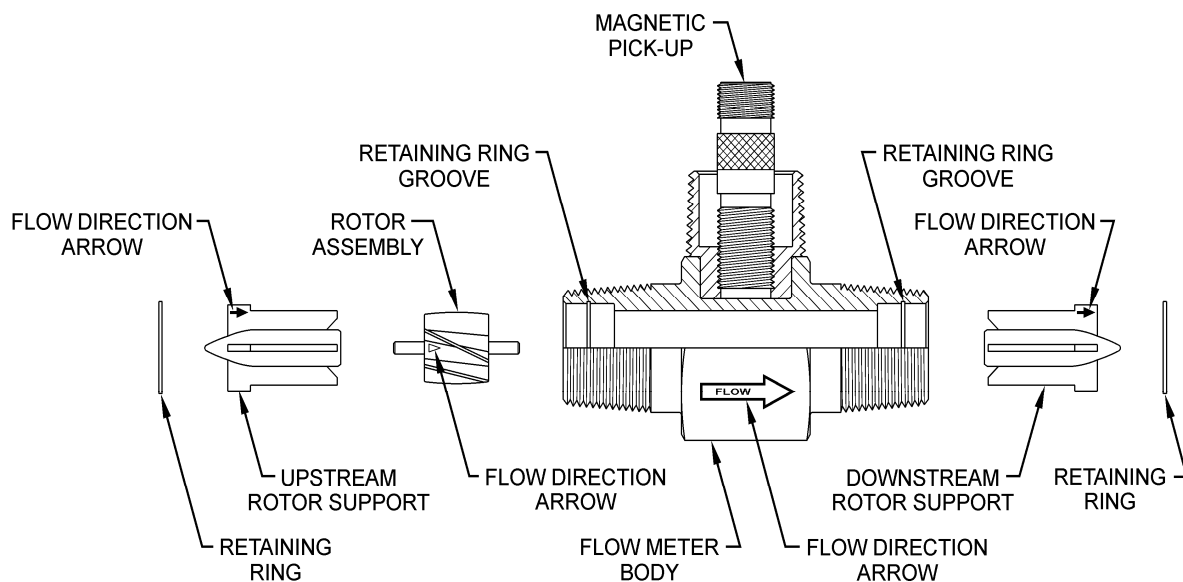

Fig. 8 Typical turbine flow meter components

A. DISASSEMBLY

Refer to Figure 8 for relative positions of repair kit components

- 1) Remove cam lock fittings.
- 2) Remove the retaining ring(s) from one end of the meter. (4 inch and larger meters have two retaining rings, one on either side of the rotor, that need to be removed before the rotor can be removed.
- 3) Remove the rotor support from the body. If the rotor support is jammed in the body, use a pair of pliers to free the rotor support.
- 4) Remove the rotor.
- 5) Remove the retaining ring(s) from the opposite side of the meter.
- 6) Remove the second rotor support.

B. INSTALLATION OF THE NEW KIT:

NOTE: Before reassembly, note that an arrow is cast or engraved on each component. The arrow indicates the direction of flow. The meter must be reassembled with arrowheads pointed in the direction of the fluid flow. Each rotor support has one of its blades notched. This notch is to be oriented in the up position on both rotor supports. The side of the meter with the magnetic pickup signifies the up position. This is the position that the repair kit was calibrated, and this is the position that it is to be used in to ensure meter accuracy. See Figures 7 & 8 for proper alignment and orientation of the repair kit.

- 1) Install one of the rotor supports into the body bore, noting the orientation of the arrow and notch.
- 2) Secure retaining ring(s) in the groove(s) provided. Be sure that the retaining rings are completely installed in each groove.
- 3) Insert the rotor and second support in the opposite side of the body, noting the orientation of the arrow and notch.
- 4) Secure the second retaining ring(s) in the opposite groove, as noted in Step 2 above.
- 5) Check the meter by blowing air through the assembly. If the rotor does not turn freely, the meter should be disassembled and checked for anything that would obstruct movement of the rotor.
- 6) Replace cam lock fittings using liquid thread sealant. Do not use Teflon tape.

CAUTION: Excess air pressure may damage the rotor and bearings by causing the rotor to spin too quickly.

NOTE: The electronics will need to be re-programmed to accept the new calibration of the repair kit if a new kit was installed. Refer to the programming section of the manual for instructions.

10. INTRODUCTION OF MONITOR:

The flow monitor supplied with the tactical fuels flow meter is a state-of-the-art, microprocessor based display, designed to provide the user with exceptional flexibility.

Features

- Displays Rate and/or Total
- Large 0.5 Inch, 8-Digit Display for Easy Viewing
- 10-Point Linearization Capability
- Microprocessor Based, Low Power Components
- Surface Mount Technology Use Throughout

WARNING: Do not open enclosure unless the area is known to be free of hazards. Failure to make the area safe before opening the enclosure can result in a hazardous situation with a potential for injury.

This flow monitor is capable of accepting a low-level frequency input for calculating flow rate and total. These calculations can then be displayed in the desired units of measurement. All monitors come pre-calibrated, from the factory, if ordered with a FloCat Flow Meter. If required, however, it can easily be re-configured in the field. This normally occurs when a turbine repair kit is installed. The monitor's large 8 digit by .5" numeric liquid crystal display makes extended range viewing practical. The second 8 digit by .25" alphanumeric display provides for selectable units viewing in run mode and prompts for variables in programming mode. Finally, the user can choose between displaying rate, total, or alternating between both rate and total.

11. SPECIFICATIONS FOR MONITOR:

Power Supply Options:	1 "D" size 3.6 Volt Lithium Battery (a 1.5 Volt Alkaline Battery can be temporarily substituted as long as the temperature is above minus 22 degrees Fahrenheit. The life expectancy of alkaline batteries may be fairly short depending upon conditions.)
Power Consumption:	Less than 1 milli-watt
Alpha-Numeric Rate and Totalization Display:	8 digit, .5" high numeric display 8 character, .25" high alphanumeric display
Pulsed Output Signal:	Outputs one pulse for each increment of the least significant digit of totalizer
Pulse Type:	Opto-Isolated open collector Transistor
Max. Voltage:	30V DC
Pulse Width ON State:	20ms/ Max pulse rate 20Hz
Current (ON State):	0.9V drop @ 5.0mA or 0.7V drop @ 0.1A
Inputs:	
Magnetic Pickup Input:	
Frequency Range:	0 to 3500 Hz
Trigger Sensitivity:	30mV p-p
Over Voltage Protected:	±30V DC
Frequency Measurement Accuracy:	±0.1%
Temperature Drift:	50 ppm / °C (Max)
Transient Overvoltages:	Category 3, accordance with IEC664
Pollution Degree:	2, in accordance with IEC664
Mounting Classification:	NEMA/UL/CSA Type 4 (IP66)
Environmental:	
Operating Temperature:	-40 °F (-40 °C) to 140 °F (60 °C)
Humidity:	0-90% Non-condensing
Certifications:	
CSA Ordinary Locations:	To: C22.2 No. 1010-1 for Canada ISA S82.02 for US
Units of Measure:	Gallons, Oil Barrels, Liters, Cubic Meters, MGal, Cubic FT, MCF, MMCF, Megltrs, Acre FT, Liq. Barrels, LBS, KGS
Time Intervals:	Day, Hour, Minute, Second

12. OPERATING THE MONITOR:

The monitor has two modes of operation referred to as the **RUN** mode and the **PROGRAM** mode. Both the run mode and the program mode display screen enunciators confirming the state of the monitor. A quick glance at the lower left hand corner of the LCD screen will confirm operating status. Normal operation will be in the run mode. To access the programming mode, press the **MENU** button until the first programming screen is displayed. After programming the display with the necessary information, a lock out feature can be turned on to prevent unauthorized access or changing the meter's setup parameters.

A. ADVANCED PROGRAMMING MODE

Keys:

MENU – Switches between RUN and PROGRAMMING modes.

UP Arrow – Scrolls through programming sub-menus in forward direction and increments numeric variables.

RIGHT Arrow – Scrolls through programming sub-menus in reverse direction and moves the active digit to the right.

ENTER – Used to enter sub-menus, save programming information and in the reset process.

If your monitor was ordered with a FloCat flow meter, the two components ship from the factory, calibrated as a set. If the monitor is a replacement, the turbine's K-Factor has changed, or the monitor is being used with some other pulse generating device, programming will be necessary.

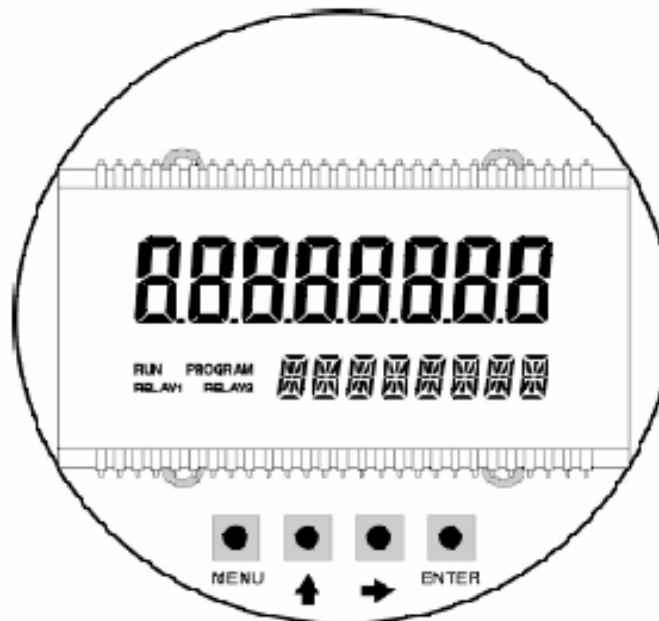

Fig. 10 Front panel

B. PROGRAMMING USING PULSE OUTPUT TURBINE FLOW METERS:

Each turbine flow meter and/or repair kit is shipped with 10 linearized K-Factor values. (See “General Notes on Scaling” at the end of this manual). K-Factor information is given on the certificate of calibration that is included in electronic format for each turbine meter and/or each repair kit. The K-Factor is the calibrated number of pulses generated per gallon of fluid. The K-Factors will be needed to program the monitor readout. In the event that K-factors are not available it is possible to determine new K-factors by flowing a known amount of fluid through the meter at a constant rate.

Enter Programming Mode – Change to programming mode by pressing the MENU button once. The mode indicator will change from RUN to PROGRAM.

If any input value exceeds the meter’s capabilities for that particular parameter the LIMIT indicator will begin to flash indicating an invalid entry. Press ENTER once to return to the parameter’s entry screen to reenter the value.

Select The Meter Size – At the METER prompt, press the ENTER button once. The current meter size number will begin to flash. Using the arrow keys, scroll through the size choices until you find the bore size of your meter. Press ENTER once to save the meter size choice.

NOTE: The meter connection size and the bore size are different. For example, many of the 1” NPT turbines have bore sizes that range from 3/8” up 1”. Be sure to use the correct bore size or the meter could report incorrect flows and totals.

Select the Display Function – The monitor can display RATE or TOTAL or alternate between BOTH rate and total. At the DISPLAY prompt, press the ENTER key once. The monitor now shows the display mode currently in effect. If the current selection is correct, press the ENTER key to advance to the next parameter. To change to an alternate display mode, use the arrow keys to scroll to the desired display mode and press ENTER to save the choice.

Select the Rate Units of Measure – The monitor allows the choice of many common rate units. (See the specifications for a complete listing of the unit choices.) At the RATE UNT prompt, press the ENTER key once. The monitor now shows the rate units of measure the display is currently set for. If the current selection is correct, press the ENTER key to advance to the next parameter. To change to an alternate unit, use the arrow keys to scroll to the desired rate unit and press ENTER to save the choice.

Select the Rate [Time] Interval – The term Rate implies that something is occurring over a period of time. Most people are familiar with the rate of speed of a car reported in miles per hour (MPH). The same concept holds true for a flow meter. The time choices are SEC (seconds), MIN (minutes), HOUR (hours), and DAY (days). At the RATE INT prompt, press the ENTER key once. The monitor now shows the time interval the display is currently set for. If the current selection is correct, press the ENTER key to advance to the next parameter. To change to an alternate time interval, use the arrow keys to scroll to the desired time interval and press ENTER to save the choice.

NOTE: If flow rate is the only measurement of interest, skip to KFAC UNT to complete the programming process.

Select the Total Units of Measure – If a flow amount is desirable, the units for the total must first be chosen. The monitor allows the choice of many common totalization units. (See the specifications for a complete listing.) At the TOTL UNT prompt, press the ENTER key once. The monitor now shows the total units of measure the display is currently set for. If the current selection is correct, press the ENTER key to advance to the next parameter. To change to an alternate unit, use the arrow keys to scroll to the desired totalization unit and press ENTER to save the choice. **Note:** This unit of measure does not have to reflect the rate unit you have previously chosen. (Example: Rate Units = Gallons, Total Units = Barrels).

Select the Total's Display Multiplier – The monitor has a very versatile display that has the ability to accumulate the flow total in multiples of ten. For example, if the most desirable totalization unit is 1,000 gallons, the monitor can easily be set up for this requirement. Once the unit is back in RUN mode, every time the total display is incremented by one digit the actual total would be an additional 1,000 gallons. At 1,000 gallons the total display would read 1, at 3,000 gallons the total display would read 3, etc. This feature eliminates having to look at a total, counting the digits and mentally inserting commas for each 1000 multiple.

At the TOTL MUL [Multiple] prompt, press the ENTER key once. The monitor now shows the multiplier the total display is currently set for. If the current selection is correct, press the ENTER key to advance to the next parameter. To change to an alternate multiplier, use the arrow keys to scroll to the desired multiplier unit and press ENTER to save the choice.

Multiplier Choices – 0.01, 0.1, 1, 10, 100, 1000, 10000, 100000, and 1000000 Units

Enter the Meter's K-Factor Unit – At the KFAC UNT prompt, press the ENTER key once. The display now shows the current K-Factor unit. If the current selection is correct, press the ENTER key to advance to the next parameter. For meters calibrated in gallons use PUL/GAL. For meters calibrated in cubic meters use PUL/M3 (pulses per cubic meter). **Note: Unless otherwise specified, turbine flow meters are supplied with K-Factors measured in pulses per gallon (PUL/GAL).** To change to an alternate K-Factor unit, use the arrow keys to scroll to the desired K-Factor unit and press the ENTER key to save your choice.

Enter the Meter's K-Factor – (**Note: The K-Factor supplied with your meter or calculated from calibration data will be needed to complete this step.**) At the K FACTOR prompt, press the ENTER key once. The most significant digit in the K-Factor will begin to flash. Using the ↑ arrow key, increment the display digit until it matches the meter's K-Factor digit. If the current selection is correct, press the → arrow key to advance to the next digit. Repeat this process until all K-Factor digits have been entered. Press ENTER once to save the K-Factor.

Scale Factor – At the SCALE F prompt, press the ENTER key once. The current Scale Factor will begin to flash. If the current selection is correct, press the ENTER key to advance to the next parameter. The scale factor is used to force a global change to all variables. For example, under operating conditions the display is reading a consistent 3% below the expected values at all flow rates. Rather than changing all parameters individually, the scale factor can be used to compensate for the 3% offset. The scale factor would be set to 1.03 to correct the readings. The range of scale factors is from 0.5 to 1.5. The default scale factor is 1.00.

Meter Type – At the METERTYP prompt, press the ENTER key once. The current meter type will be displayed as "Liquid" or "Gas." If the current selection is correct, press the ENTER key to advance to the next parameter. If "Gas" is selected you must then enter the Operating Pressure and Operating Temperature before advancing to the next parameter.

Damping Factor – At the DAMPING prompt, press the ENTER key once. The current Damping setting will begin to flash. If the current selection is correct, press the ENTER key to advance to the next parameter. The Damping Factor is increased to enhance the stability of the flow readings. Damping values are decreased to allow the flow meter to react faster to changing values of flow. This parameter can take on any value between 0 and 99 with 0 being the default.

Totalizer Pulse Output – The pulse output parameter can be either enabled or disabled. When enabled this output generates 20mS duration pulse for every time the least significant digit of the totalizer increments. The amplitude of the pulse is dependent on the voltage level of the supply connected to the pulse output and is limited to a maximum 30 VDC.

Linearization – Enhanced accuracy can be obtained by linearization of the display. The linearization routine will accept a maximum of ten points. Linearization requires additional calibration data from the meter to be used with the monitor. Typically, calibration information can be obtained in three, five, and ten points from the flow meter's manufacturer. If linearization is not needed, pressing the → arrow key will take you to the next parameter. (See "General Notes on Scaling" for more information).

Number of Points – At the LINEAR prompt, press ENTER once. The NUM PTS number will be displayed. Press ENTER to set the number of points you wish to use. Again, the **UP** arrow key increments the value and the **RIGHT** arrow moves the cursor between digits. When the number of points has been input, press the ENTER key once to move to the first linear segment.

Press the ENTER key once and the first linear point's frequency input will begin to flash (FREQ 1). Enter the frequency for the first linear point using the arrow keys. When the frequency value input is completed, press ENTER once again to change to the coefficient value for the first linear point.

The coefficient is the value applied to the nominal K-Factor to correct it to the exact K-Factor for that point. The coefficient is calculated by dividing the actual K-Factor for that point by the average K-Factor for the flow meter.

$$\text{Coefficient} = \text{Actual K-Factor} \div \text{Average K-Factor}$$

At the COEFF prompt, enter the coefficient that corresponds to the frequency value previously entered. Press ENTER once to move to the next scaling point.

Continue entering pairs of frequency and coefficient points until all data has been entered. Press the MENU key twice at the NUM PTS prompts to exit to the LINEAR prompt. Press the → arrow key to move to the next parameter.

Password – Password protection prevents unauthorized users from changing programming information. Initially, the password is set to all zeros. To change the password, press ENTER once at the password prompt. The first digit of the password value will begin to flash. Using the arrow keys as previously described, enter the password value. Pressing ENTER once will store the password and take you back to the RST PSWD screen.

NOTE: Password will allow users to reset totals.

RST PSWD – Reset Password protection prevents unauthorized users from manually resetting the flow monitor's accumulated totals. Initially, the password is set to all zeros. To change the password, press ENTER once at the password prompt. The first digit of the password value will begin to flash. Using the arrow keys as previously described, enter the password value.

Pressing ENTER once will store the password and take you back to the METER size screen, pressing MENU exits the programming mode. The tactical fuels flow meter monitor is now ready for use with its companion meter.

NOTE: Entering a password in the Password screen and leaving the password blank in the RST PSWD screen would allow for total resets (not requiring password) and restrict programming modification.

Reset Total – To reset the monitor total display, in run mode press the MENU and ENTER simultaneously until TOTAL RST starts to flash. The TOTAL RST will stop flashing and the display will return to the run mode at the conclusion of the procedure.

Store Total – The current total can be manually stored in the monitor's flash memory. This procedure may be desirable prior to changing the settings or replacing the battery. Press and hold the ENTER key for 2 seconds. The display will respond with a flashing TOTALSVD and then return to the run mode.

Automatic Store Total – The monitor is equipped with a store total feature that works automatically, saving the current total to flash memory. The frequency of saves depends on the power supply option chosen

Battery Powered: Once per hour and just before a low battery condition turns the unit off.
Loop Powered: Once every ten minutes.

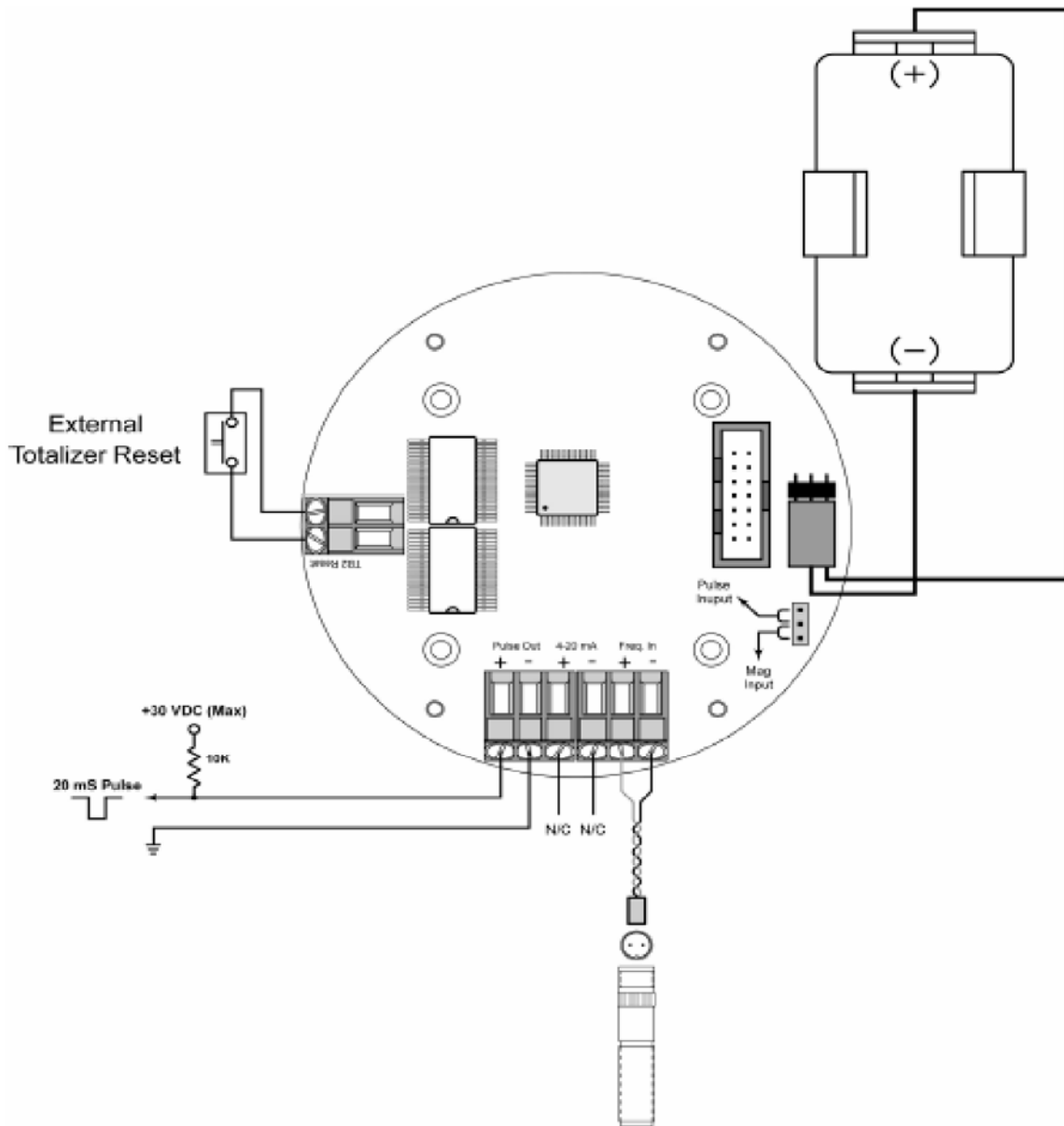

Fig. 11 Explosion proof circuit board layout (battery powered)

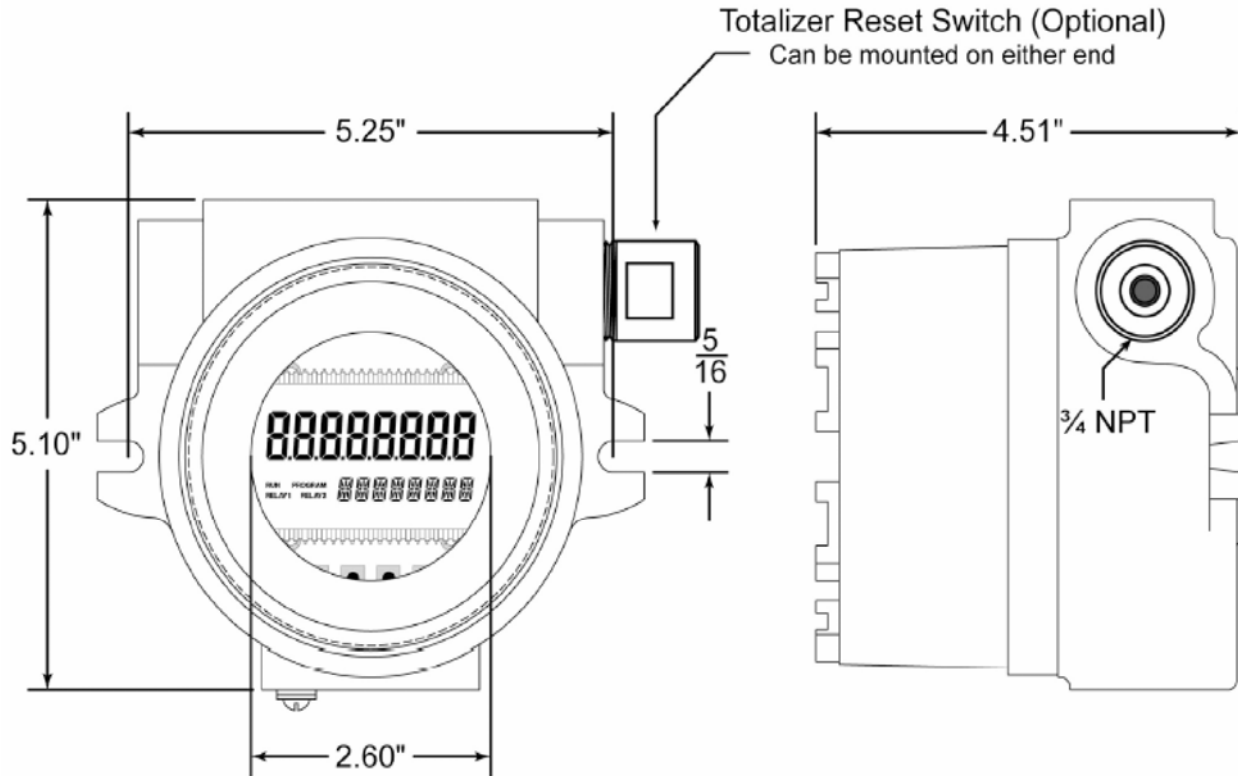

Fig. 12 Explosion proof enclosure

13. BATTERY REPLACEMENT

Battery powered monitors use a single 3.6V, D size, lithium battery. When replacement is necessary, use a clean fresh battery to ensure continued trouble free operation. It is recommended that the total be saved to memory before the battery is removed. (See "Store Total" in the programming section of this manual.)

WARNING: Do not open enclosure unless the area is known to be free of hazards. Failure to make the area safe before opening the enclosure can result in a hazardous situation with a potential for injury.

Carefully unscrew the enclosure cover to access the circuit board. Remove the four screws securing the circuit board to the enclosure. Lay the circuit board to the side being careful not to pull any wires from their connections. Clip the battery retaining wire/strap and remove the battery. Replace the battery being sure to observe the proper polarity and install a new retaining strap or wire. Reassemble the monitor reversing the disassembly process.

14. MONITOR ENCLOSURE INSTALLATION

A. INSTALLATION

WARNING: Electrical power must be “OFF” before and during installation and maintenance.

1. Instrument enclosures are furnished with $\frac{3}{4}$ " NPT offset through-feed cast hubs for conduit entries. Instrument enclosures are supplied with $\frac{3}{4}$ " NPT offset through-feed cast hubs on the power side and one $\frac{3}{4}$ " NPT hub on the instrument side for conduit entries.
2. Secure the enclosure to the conduit system. Using the enclosure's mounting feet, bolt the enclosure to the roll cage.

CAUTION: All unused conduit openings must be plugged. Plugs must be a minimum of 1/8" thick and engage a minimum of 5 full threads.

3. Un-thread instrument (and power side) covers and carefully set aside to prevent damage to the cover threads and glass lens (when glass lens cover is used).
4. Pull wires into enclosure making certain they are long enough to make the required connections and to remove the instrument or power supply if servicing is required. Install instrument and power supply, if applicable and make all electrical connections.

NOTE: When installing device be sure to check instrument dimensions to avoid interference with clamping ring on glass lens and the cover on standard units.

5. Carefully re-thread cover to enclosure housing. Tighten cover until cover flange contacts body face.

CAUTION: Use care to prevent dirt, grit or other foreign material from lodging on threads. If any such material settles on these threads, clean them with Kerosene or Stoddard solvent*, then re-lubricate with thread lubricant.

****To avoid the possibility of an explosion, oxidation and corrosion, do not use gasoline or similar solvent.***

6. Tighten cover set screws to prevent cover from loosening under vibration.

B. MAINTENANCE

WARNING: Always disconnect primary power source before opening enclosure for inspection or service.

1. Frequent inspection should be made. A schedule for maintenance checks should be determined by the environment and frequency of use. It is recommended that it should be at least once a year.
2. Perform visual, electrical and mechanical checks on all components on a regular basis.
 - A) Visually check for undue heating evidenced by discoloration of wires or other components, damaged or worn parts, or leakage evidenced by water or corrosion in the interior.
 - B) Electrically check to make sure that all connections are clean and tight and that the device is operating correctly.

15. PROGRAMMING MENU DIAGRAM

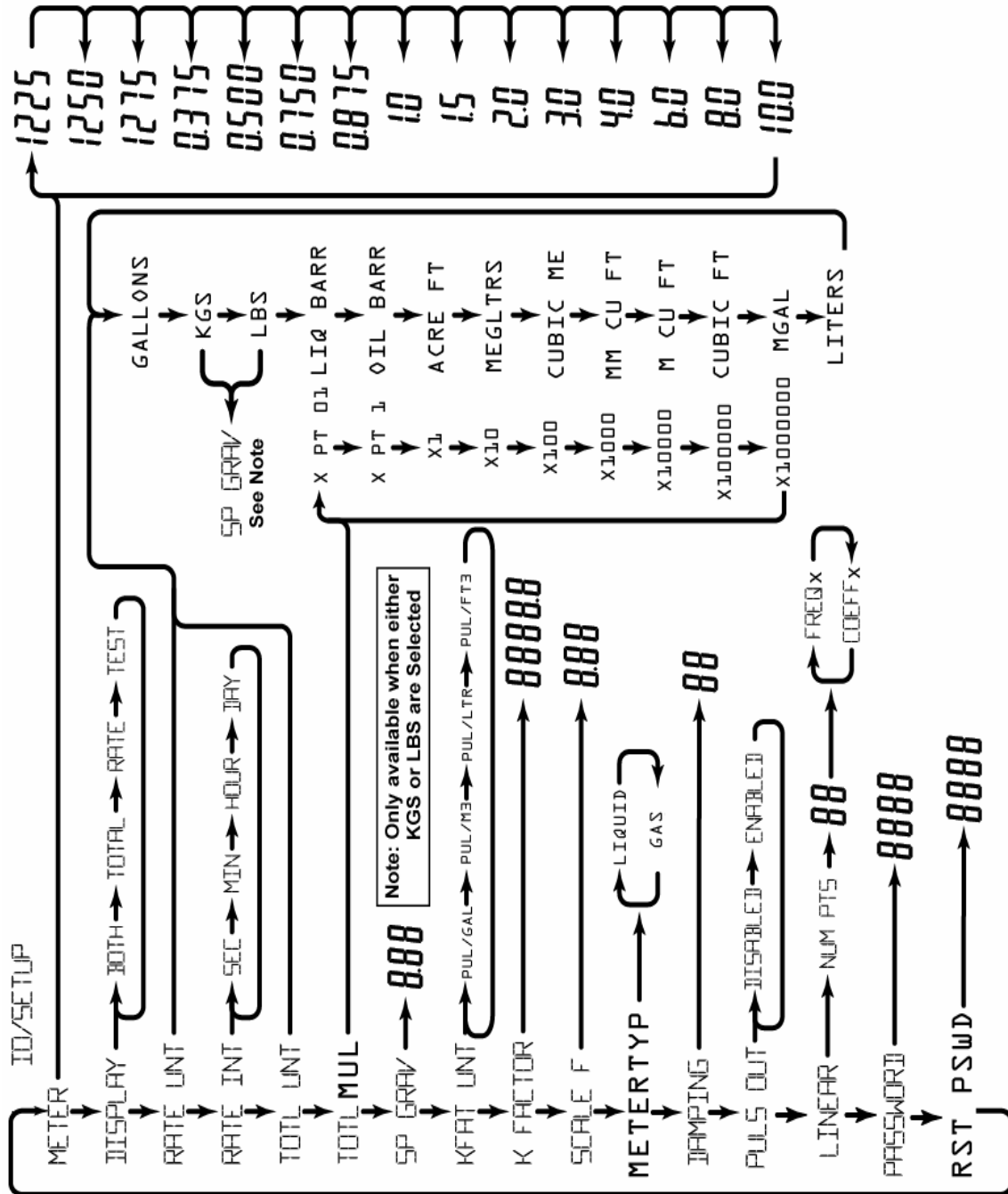

Fig. 13 Programming menu

16. TROUBLESHOOTING THE MONITOR

1) No LCD Display

- For Battery powered version
Check Battery Voltage. Should be 3.6VDC (replace if low).
- For Loop powered version
Check for current flow in the loop.
Check polarity of the current loop connections for proper orientation.

2) No Rate or Total Displayed

- Check connection from meter pickup to display input terminals.
- Check turbine meter rotor for debris. Rotor should spin freely.
- Check Programming of Flow Monitor.
- Check to see that the minimum flow rate is being met for the current meter in use, otherwise, the flow meter will not accurately send pulses to the flow monitor.

3) Flow rate display reads a constant reading all the time

- This is usually an indication of external noise. Keep all AC wires separate from DC wires.
- Check for large motors close to the meter pickup.
- Check for radio antenna in close proximity.
- Try disconnecting the pickup from the monitor pig tail. This should stop the noise. If so, then try re-orientating the meter to a new location.

4) Flow rate indicator bounces

- This usually indicates a weak signal. Replace pickup and/or check all connections.
- Examine K-Factor.

Default K-Factor Values			
Meter Size	Default K-Factor	Lower Limit	Upper Limit
0.375	20,000	16,000	24,000
0.500	13,000	10,400	15,600
0.750	2,750	2,200	3,300
0.875	2,686	2,148	3,223
1.000	870.0	696.0	1,044
1.500	330.0	264.0	396.0
2.000	52.0	41.6	62.0
3.000	57.0	45.6	68.0
4.000	29.0	23.2	35.0
6.000	7.0	5.6	8.0
8.000	3.0	2.4	4.0
10.000	1.6	1.3	2.0

17. GENERAL NOTES ON SCALING

This information is supplied as a general introduction to the basic concepts used to scale rate displays. The applicability of the information is dependent of the type and capabilities of the specific display/monitor used.

Flow meters producing an electronic signal are normally supplied in one of two output formats. The pulse format generates some form of alternating signal that can be “raw,” that is, no amplification or wave shaping can be done prior to transmission to the readout. The output pulse rate is related proportionally to flow rate. Pulses can also be modified to produce higher output amplitudes or specific wave shapes.

The other output format is an analog signal. This is a continuously variable voltage or current signal that is normally scaled to the dynamic range of the flow meter. Typical analog signals are 0-5VDC, 0-10VDC, and 4-20mA. The analog signals may or may not be derived from a raw pulse signal produced by the flow meter.

Scaling for any of these input signals always requires at least two scaling points for a linear process, a zero or minimum flow point and the maximum flow point. Additionally, each scaling point has two components. The first is the actual input signal value and the second is the desired display value at that input signal, for that scaling point.

For example, a pulse output flow meter has a flow of 50GPM at a pulse rate of 100Hz. The actual input signal is the 100Hz figure but allowing the display to read “100” would be meaningless to the operator. The solution to this problem is to “scale” the display to “read” 50 (GPM) when the input is 100Hz.

Pulse Output Signals for Linear Processes (for applications where linearization is not necessary)

Pulse output signals are related to flow rate by a constant, usually referred to as the “K-Factor.” The K-Factor is reported as the number of accumulated pulses that represents a particular volume such as gallon or liter. K-Factors are indicated in pulses per unit volume or counts per unit volume. An example of a K-Factor, normally supplied by the meter’s manufacturer, might be 2000 counts per gallon.

The K-Factor is correlated to flow through a simple mathematical relationship

$$\text{Frequency} = \text{K-Factor} \times \text{Volume per unit of time} \div 60$$

Using the previous example of 2000 counts per gallon and further assuming this meter has a maximum flow rate of 25GPM, the formula can be rearranged to calculate the input frequency required for a scaling point as follows.

$$\text{Frequency} = 2,000 \times 1(\text{gallon}) \div 60 = 33.333\text{Hz at } 1\text{GPM}$$

Given that the meter has a maximum flow rate of 25GPM the maximum frequency would then be:

$$\text{Frequency} = 2,000 \times 25(\text{gallons}) \div 60 = 833.333\text{Hz at } 25\text{GPM}$$

A programmable display requires at least two points. The first point is going to be the zero or minimum flow and the second would normally be the maximum flow rate. For the imaginary flow meter used in the example above, the scaling would be as follows:

Input Value for Scaling Point 1 = 0
 Display Value for Scaling Point 1 = 0

Input Value for Scaling Point 2 = 833.33
 Display Value for Scaling Point 2 = 25

**Pulse Output Signals for Non-Linear Processes
 (for applications that can benefit from linearization)**

Few flow meters actually behave in a linear way. There is always some uncertainty about the “exact” flow at a given reported input value. For many common flow measurement applications the assumption of linear flow is adequate for the process being measured. When higher accuracy is required, a technique called “Linearization” is often employed.

When the flow meter is being calibrated, multiple data points are obtained for the particular meter being tested. A typical five point calibration run is displayed below.

GPM	AVG Frequency	UUT Hz Counts/GAL	UUT K(Hz*60)/NK GPM	ERROR % FS
15.00	769.7	3,078.59	14.90	-0.65
9.06	466.1	3,086.75	9.03	-0.38
5.49	285.2	3,118.64	5.52	0.65
3.32	171.7	3,103.95	3.32	0.17
2.00	103.6	3,101.80	2.01	0.10

UUT = Unit Under Test

If this meter produced an actual linear output, the K-Factor calculation for the Unit Under Test would be exactly the same for each measurement point. Inspection of the UUT in the example above shows that this is not the case and indicates that this meter is not a perfectly linear device.

Many programmable displays allow for linearization and can provide a better match of the displayed flow values with the actual flow values by incorporating more measurement points. In the example, the unit would be programmed for six points, the five data points and a zero point, and use pairs of input values to accomplish the linearization.

APPENDIX A

TROUBLE SHOOTING GUIDE

TROUBLE	POSSIBLE CAUSE	REMEDY
Meter indicates higher than actual flow rate	Cavitation Debris on rotor support Build up of foreign material on meter bore. Gas in liquid	Increase back pressure Clean meter Clean meter Install gas eliminator ahead of meter
Meter indicates lower than actual flow rate	Debris on rotor Worn bearing Viscosity higher than calibrated	Clean meter and add filter Clean meter and add filter Recalibrate monitor
Erratic system indication, meter alone works well (remote monitor application only)	Ground loop in shielding	Ground shield one place only. Look for internal electronic instrument ground. Reroute cables away from electrical noise.
Indicator shows flow when shut off.	Mechanical vibration causes rotor to oscillate without turning	Isolate meter
No flow indication. Full or partial open position	Fluid shock, full flow into dry meter or impact caused bearing separation or broken rotor shaft.	Rebuild meter with repair kit and recalibrate monitor. Move to location where meter is full on start-up or add downstream flow control valve.
Erratic indication at low flow, good indication at high flow	Rotor has foreign material wrapped around it.	Clean meter and add filter
No flow indication	Faulty pick-up	Replace pick-up.
System works perfect, except indicates lower flow over entire range	Bypass flow, leak	Repair or replace bypass valves, or faulty solenoid valves.
Meter indicating high flow, upstream piping at meter smaller than meter bore	Fluid jet impingement on rotor.	Change piping.
Opposite effects of above	Viscosity lower than calibrated	Change temperature, change fluid or recalibrate meter.

APPENDIX B REPLACEMENT PARTS

TURBINE REPAIR KIT INFORMATION

Part Description	Fits Meter Part No.	Part Number	Manufacturer
2" Repair Kit	C-LB45-A006-MIL	C-LB80-251116-MIL	FloCat
4" Repair Kit	C-LB45-A009-MIL	C-LB80-251141-MIL	FloCat
6" Repair Kit	C-LB45-A010-MIL	C-LB80-251161-MIL	FloCat
Standard Magnetic Pick-up	All Meter Sizes	C-LB85-A005	Flocat

Repair kit includes all components in figure 13 except for turbine body and magnetic pick-up.
Quantity of repair kits needed per meter (regardless of size) is one each.

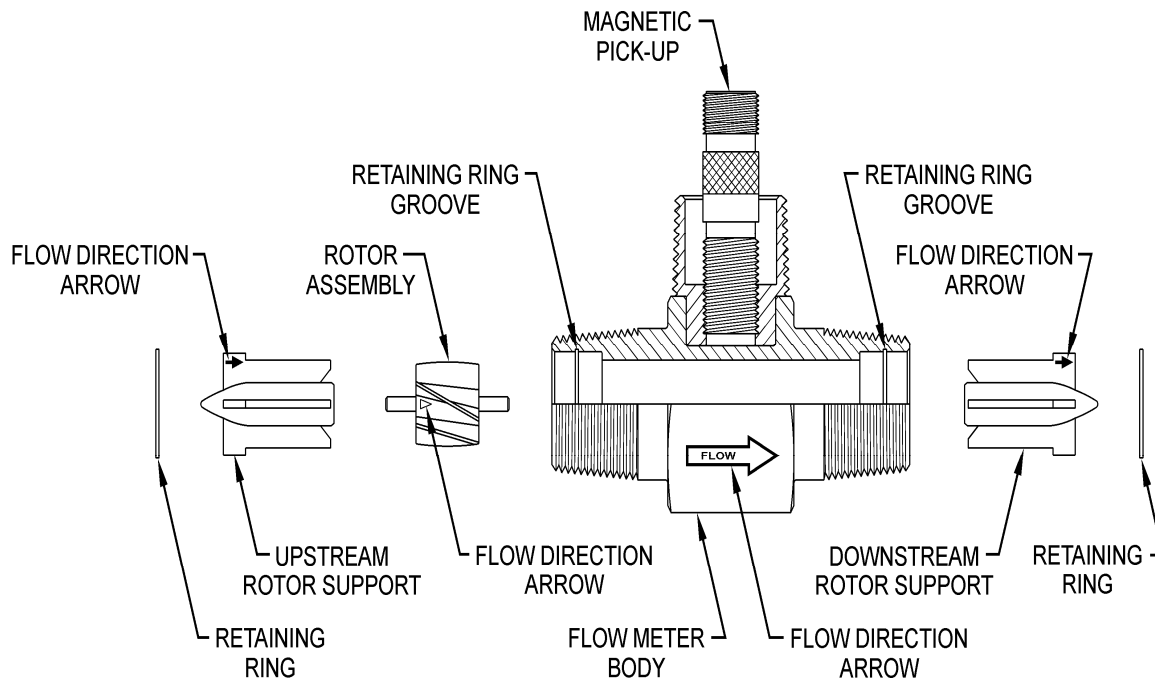

Fig. 14 Typical turbine meter components

CAUTION: Always reassemble rotor supports, rotor, and meter body with flow arrows pointing in the same direction.

ELECTRONICS REPAIR PARTS INFORMATION

Part Description	Fits Meter Part No.	Part Number	Manufacturer	CAGE Code	NSN Number	Quantity/Meter		
						2"	4"	6"
2" Repair Kit	C-LB45-A006-MIL	C-LB80-251116-MIL	FloCat	1VL38		1	0	0
4" Repair Kit	C-LB45-A009-MIL	C-LB80-251141-MIL	FloCat	1VL38		0	1	0
6" Repair Kit	C-LB45-A010-MIL	C-LB80-251161-MIL	FloCat	1VL38		0	0	1
Standard Magnetic Pickup	All Meter Sizes	C-LB85-A005	FloCat	1VL38		1	1	1
Electronics Assembly (comes installed in	All	C-LB75-C005-MIL	FloCat	1VL38		1	2	2
Reset Switch	All	C-LB85-Reset Switch	FloCat	1VL38		1	1	1
Lithium Battery, "D Cell"	All	TL-2300	Tadrian	4J947		1	2	2
Electronics Enclosure	All	EIH21 MF	Cooper Crouse-Hinds	1F7D7		1	2	2
3/4" NPT Male Plug, Aluminum	All	BX118236	FloCat	1VL38		0	1	1
Harness, Wire	All	BX311-089	Blancett	59380		1	1	1
Battery Support Plate	All	BX280618	Blancett	59380		1	2	2
Screw, Flat Head #4-40X3/8", 18-8	All	BX280620	FloCat	1VL38		4	8	8
Screw, Pan Head #4-40X3/16", 18-8	All	BX280623	FloCat	1VL38		4	8	8
Battery Bracket Assembly, D-Cell	All	BX280634	Blancett	59380		1	2	2
Standoff, #4-40X2-1/4"; Female-female	All	BX280667	FloCat	1VL38		4	8	8
Screw, Slotted Machine 4-40X3/8"	All	BX220328	FloCat	1VL38		4	8	8
Desiccant bag	All	BX220141	FloCat	1VL38		1	2	2
Screw, Flat Head, #4-40X3/16", Zinc	All	BX280678	FloCat	1VL38		4	8	8
Cable Tie for Battery	All	BX228036	FloCat	1VL38		1	2	2
Adapter/Bridge Plate	All	BX280677	Blancett	59380		1	2	2
PCB Assembly; Battery Powered, Extended	All	C-LB80-280691	FloCat	1VL38		1	2	2

MISCELLANEOUS PARTS

Part Description	Fits meter Part No.	Part Number	Manufacturer	CAGE Code	NSN Number	Quantity/ Meter		
						2"	4"	6"
Fitting, Cam Lock, 2", Male, Aluminum	C-LB45-A006-MIL	Camlock 2" NPT (M) AL	FloCat	1VL38		1	0	0
Fitting, Cam Lock, 2", Female, Aluminum	C-LB45-A006-MIL	Camlock 2" NPT (F) AL	FloCat	1VL38		1	0	0
Fitting, Cam Lock, 4", Male, Aluminum	C-LB45-A009-MIL	Camlock 4" NPT (M) AL	FloCat	1VL38		0	1	0
Fitting, Cam Lock, 4", Female, Aluminum	C-LB45-A009-MIL	Camlock 4" NPT (F) AL	FloCat	1VL38		0	1	0
Fitting, Cam Lock, 6", Male, Aluminum	C-LB45-A010-MIL	Camlock 6" NPT (M) AL	FloCat	1VL38		0	0	1
Fitting, Cam Lock, 6", Female, Aluminum	C-LB45-A010-MIL	Camlock 6" NPT (F) AL	FloCat	1VL38		0	0	1
Roll Cage, Small	C-LB45-A006-MIL	Rollcage Small	FloCat	1VL38		1	0	0
Roll Cage, Medium	C-LB45-A009-MIL	Rollcage Medium	FloCat	1VL38		0	1	0
Roll Cage, Large	C-LB45-A010-MIL	Rollcage Large	FloCat	1VL38		0	0	1

APPENDIX C

TEMPERATURE COMPENSATION TABLES FOR 2" METERS

Temperature °C	#1 Diesel	Jet-A	Jet A-1	JP-8	#2 Diesel	JP-5	#4 Diesel
	Resolution Factor						
-32	0.9222	0.9222	0.9222	0.9222	0.9367	0.9367	-
-31	0.9226	0.9226	0.9226	0.9226	0.9354	0.9354	-
-30	0.9229	0.9229	0.9229	0.9229	0.9342	0.9342	-
-29	0.9232	0.9232	0.9232	0.9232	0.9330	0.9330	-
-28	0.9235	0.9235	0.9235	0.9235	0.9316	0.9316	-
-27	0.9237	0.9237	0.9237	0.9237	0.9303	0.9303	-
-26	0.9240	0.9240	0.9240	0.9240	0.9290	0.9290	-
-25	0.9244	0.9244	0.9244	0.9244	0.9277	0.9277	-
-24	0.9247	0.9247	0.9247	0.9247	0.9265	0.9265	-
-23	0.9251	0.9251	0.9251	0.9251	0.9254	0.9254	-
-22	0.9255	0.9255	0.9255	0.9255	0.9244	0.9244	-
-21	0.9261	0.9261	0.9261	0.9261	0.9234	0.9234	-
-20	0.9267	0.9267	0.9267	0.9267	0.9227	0.9227	-
-19	0.9274	0.9274	0.9274	0.9274	0.9222	0.9222	-
-18	0.9282	0.9282	0.9282	0.9282	0.9220	0.9220	-
-17	0.9290	0.9290	0.9290	0.9290	0.9220	0.9220	-
-16	0.9298	0.9298	0.9298	0.9298	0.9220	0.9220	-
-15	0.9308	0.9308	0.9308	0.9308	0.9220	0.9220	-
-14	0.9318	0.9318	0.9318	0.9318	0.9220	0.9220	-
-13	0.9330	0.9330	0.9330	0.9330	0.9220	0.9220	-
-12	0.9344	0.9344	0.9344	0.9344	0.9220	0.9220	-
-11	0.9358	0.9358	0.9358	0.9358	0.9220	0.9220	-
-10	0.9377	0.9377	0.9377	0.9377	0.9221	0.9221	-
-9	0.9398	0.9398	0.9398	0.9398	0.9224	0.9224	-
-8	0.9422	0.9422	0.9422	0.9422	0.9227	0.9227	-
-7	0.9450	0.9450	0.9450	0.9450	0.9231	0.9231	-
-6	0.9478	0.9478	0.9478	0.9478	0.9236	0.9236	-
-5	0.9506	0.9506	0.9506	0.9506	0.9241	0.9241	-
-4	0.9538	0.9538	0.9538	0.9538	0.9247	0.9247	-
-3	0.9568	0.9568	0.9568	0.9568	0.9253	0.9253	-
-2	0.9600	0.9600	0.9600	0.9600	0.9259	0.9259	-
-1	0.9630	0.9630	0.9630	0.9630	0.9266	0.9266	-
0	0.9657	0.9657	0.9657	0.9657	0.9272	0.9272	-
1	0.9684	0.9684	0.9684	0.9684	0.9279	0.9279	-
2	0.9714	0.9714	0.9714	0.9714	0.9287	0.9287	-
3	0.9744	0.9744	0.9744	0.9744	0.9296	0.9296	-
4	0.9774	0.9774	0.9774	0.9774	0.9305	0.9305	-
5	0.9802	0.9802	0.9802	0.9802	0.9314	0.9314	-
6	0.9832	0.9832	0.9832	0.9832	0.9323	0.9323	-
7	0.9858	0.9858	0.9858	0.9858	0.9331	0.9331	-
8	0.9882	0.9882	0.9882	0.9882	0.9339	0.9339	-
9	0.9904	0.9904	0.9904	0.9904	0.9346	0.9346	-
10	0.9922	0.9922	0.9922	0.9922	0.9352	0.9352	0.8664
11	0.9934	0.9934	0.9934	0.9934	0.9356	0.9356	0.8683
12	0.9944	0.9944	0.9944	0.9944	0.9359	0.9359	0.8701
13	0.9952	0.9952	0.9952	0.9952	0.9361	0.9361	0.8720
14	0.9958	0.9958	0.9958	0.9958	0.9363	0.9363	0.8738
15	0.9962	0.9962	0.9962	0.9962	0.9364	0.9364	0.8757
16	0.9967	0.9967	0.9967	0.9967	0.9365	0.9365	0.8775
17	0.9710	0.9710	0.9710	0.9710	0.9366	0.9366	0.8793
18	0.9750	0.9750	0.9750	0.9750	0.9367	0.9367	0.8812
19	0.9979	0.9979	0.9979	0.9979	0.9369	0.9369	0.8830
20	0.9982	0.9982	0.9982	0.9982	0.9372	0.9372	0.8849
21	0.9986	0.9986	0.9986	0.9986	0.9375	0.9375	0.8867
22	0.9989	0.9989	0.9989	0.9989	0.9378	0.9378	0.8885
23	0.9991	0.9991	0.9991	0.9991	0.9380	0.9380	0.8904
24	0.9993	0.9993	0.9993	0.9993	0.9383	0.9383	0.8922
25	0.9995	0.9995	0.9995	0.9995	0.9387	0.9387	0.8941
Temperature	#1 Diesel	Jet-A	Jet A-1	JP-8	#2 Diesel	JP-5	#4 Diesel

°C	Resolution Factor						
26	0.9996	0.9996	0.9996	0.9996	0.9390	0.9390	0.8959
27	0.9997	0.9997	0.9997	0.9997	0.9394	0.9394	0.8978
28	0.9998	0.9998	0.9998	0.9998	0.9400	0.9400	0.8996
29	0.9999	0.9999	0.9999	0.9999	0.9407	0.9407	0.9014
30	1.0000	1.0000	1.0000	1.0000	0.9417	0.9417	0.9033
31	1.0000	1.0000	1.0000	1.0000	0.9429	0.9429	0.9051
32	1.0000	1.0000	1.0000	1.0000	0.9444	0.9444	0.9070
33	1.0000	1.0000	1.0000	1.0000	0.9461	0.9461	0.9088
34	1.0000	1.0000	1.0000	1.0000	0.9478	0.9478	0.9106
35	1.0000	1.0000	1.0000	1.0000	0.9496	0.9496	0.9125
36	1.0000	1.0000	1.0000	1.0000	0.9517	0.9517	0.9143
37	1.0000	1.0000	1.0000	1.0000	0.9538	0.9538	0.9162
38	1.0000	1.0000	1.0000	1.0000	0.9559	0.9559	0.9180
39	1.0000	1.0000	1.0000	1.0000	0.9580	0.9580	0.9199
40	1.0000	1.0000	1.0000	1.0000	0.9602	0.9602	0.9217
41	1.0000	1.0000	1.0000	1.0000	0.9626	0.9626	0.9220
42	1.0000	1.0000	1.0000	1.0000	0.9649	0.9649	0.9221
43	1.0000	1.0000	1.0000	1.0000	0.9674	0.9674	0.9222
44	1.0000	1.0000	1.0000	1.0000	0.9702	0.9702	0.9223
45	1.0000	1.0000	1.0000	1.0000	0.9728	0.9728	0.9225
46	1.0000	1.0000	1.0000	1.0000	0.9754	0.9754	0.9227
47	1.0000	1.0000	1.0000	1.0000	0.9779	0.9779	0.9229
48	1.0000	1.0000	1.0000	1.0000	0.9803	0.9803	0.9232
49	1.0000	1.0000	1.0000	1.0000	0.9824	0.9824	0.9236
50	1.0000	1.0000	1.0000	1.0000	0.9842	0.9842	0.9242
51	1.0000	1.0000	1.0000	1.0000	0.9856	0.9856	0.9248
52	1.0000	1.0000	1.0000	1.0000	0.9867	0.9867	0.9255
53	1.0000	1.0000	1.0000	1.0000	0.9877	0.9877	0.9263
54	1.0000	1.0000	1.0000	1.0000	0.9884	0.9884	0.9271
55	1.0000	1.0000	1.0000	1.0000	0.9892	0.9892	0.9279
56	1.0000	1.0000	1.0000	1.0000	0.9898	0.9898	0.9289
57	1.0000	1.0000	1.0000	1.0000	0.9904	0.9904	0.9300
58	1.0000	1.0000	1.0000	1.0000	0.9910	0.9910	0.9312
59	1.0000	1.0000	1.0000	1.0000	0.9915	0.9915	0.9326
60	1.0000	1.0000	1.0000	1.0000	0.9922	0.9922	0.9342
61	1.0000	1.0000	1.0000	1.0000	0.9929	0.9929	0.9360
62	1.0000	1.0000	1.0000	1.0000	0.9935	0.9935	0.9380
63	1.0000	1.0000	1.0000	1.0000	0.9941	0.9941	0.9402
64	1.0000	1.0000	1.0000	1.0000	0.9948	0.9948	0.9426
65	1.0000	1.0000	1.0000	1.0000	0.9954	0.9954	0.9451
66	1.0000	1.0000	1.0000	1.0000	0.9959	0.9959	0.9476
67	1.0000	1.0000	1.0000	1.0000	0.9965	0.9965	0.9502
68	1.0000	1.0000	1.0000	1.0000	0.9970	0.9970	0.9528
69	1.0000	1.0000	1.0000	1.0000	0.9976	0.9976	0.9552
70	1.0000	1.0000	1.0000	1.0000	0.9982	0.9982	0.9577

Correction factors are based on this group of hydrocarbons.

TEMPERATURE COMPENSATION TABLES FOR 4" METERS

Temperature °C	#1 Diesel	Jet-A	Jet A-1	JP-8	#2 Diesel	JP-5	#4 Diesel
	Resolution Factor						
-32	0.9944	0.9944	0.9944	0.9944	0.9926	0.9926	-
-31	0.9945	0.9945	0.9945	0.9945	0.9927	0.9927	-
-30	0.9945	0.9945	0.9945	0.9945	0.9929	0.9929	-
-29	0.9946	0.9946	0.9946	0.9946	0.9932	0.9932	-
-28	0.9946	0.9946	0.9946	0.9946	0.9932	0.9932	-
-27	0.9946	0.9946	0.9946	0.9946	0.9934	0.9934	-
-26	0.9947	0.9947	0.9947	0.9947	0.9936	0.9936	-
-25	0.9947	0.9947	0.9947	0.9947	0.9934	0.9934	-
-24	0.9948	0.9948	0.9948	0.9948	0.9934	0.9934	-
-23	0.9948	0.9948	0.9948	0.9948	0.9934	0.9934	-
-22	0.9949	0.9949	0.9949	0.9949	0.9941	0.9941	-
-21	0.9950	0.9950	0.9950	0.9950	0.9943	0.9943	-
-20	0.9951	0.9951	0.9951	0.9951	0.9944	0.9944	-
-19	0.9953	0.9953	0.9953	0.9953	0.9945	0.9945	-
-18	0.9954	0.9954	0.9954	0.9954	0.9947	0.9947	-
-17	0.9956	0.9956	0.9956	0.9956	0.9948	0.9948	-
-16	0.9958	0.9958	0.9958	0.9958	0.9949	0.9949	-
-15	0.9961	0.9961	0.9961	0.9961	0.9950	0.9950	-
-14	0.9963	0.9963	0.9963	0.9963	0.9951	0.9951	-
-13	0.9965	0.9965	0.9965	0.9965	0.9952	0.9952	-
-12	0.9967	0.9967	0.9967	0.9967	0.9953	0.9953	-
-11	0.9969	0.9969	0.9969	0.9969	0.9954	0.9954	-
-10	0.9971	0.9971	0.9971	0.9971	0.9954	0.9954	-
-9	0.9973	0.9973	0.9973	0.9973	0.9954	0.9954	-
-8	0.9973	0.9973	0.9973	0.9973	0.9954	0.9954	-
-7	0.9976	0.9976	0.9976	0.9976	0.9954	0.9954	-
-6	0.9977	0.9977	0.9977	0.9977	0.9953	0.9953	-
-5	0.9979	0.9979	0.9979	0.9979	0.9953	0.9953	-
-4	0.9980	0.9980	0.9980	0.9980	0.9952	0.9952	-
-3	0.9982	0.9982	0.9982	0.9982	0.9952	0.9952	-
-2	0.9983	0.9983	0.9983	0.9983	0.9952	0.9952	-
-1	0.9984	0.9984	0.9984	0.9984	0.9515	0.9515	-
0	0.9985	0.9985	0.9985	0.9985	0.9952	0.9952	-
1	0.9986	0.9986	0.9986	0.9986	0.9953	0.9953	-
2	0.9987	0.9987	0.9987	0.9987	0.9955	0.9955	-
3	0.9988	0.9988	0.9988	0.9988	0.9956	0.9956	-
4	0.9989	0.9989	0.9989	0.9989	0.9958	0.9958	-
5	0.9990	0.9990	0.9990	0.9990	0.9960	0.9960	-
6	0.9991	0.9991	0.9991	0.9991	0.9962	0.9962	-
7	0.9992	0.9992	0.9992	0.9992	0.9964	0.9964	-
8	0.9993	0.9993	0.9993	0.9993	0.9965	0.9965	-
9	0.9993	0.9993	0.9993	0.9993	0.9967	0.9967	-
10	0.9994	0.9994	0.9994	0.9994	0.9968	0.9968	0.9664
11	0.9995	0.9995	0.9995	0.9995	0.9969	0.9969	0.9672
12	0.9995	0.9995	0.9995	0.9995	0.9969	0.9969	0.9680
13	0.9996	0.9996	0.9996	0.9996	0.9970	0.9970	0.9688
14	0.9996	0.9996	0.9996	0.9996	0.9970	0.9970	0.9696
15	0.9997	0.9997	0.9997	0.9997	0.9970	0.9970	0.9704
16	0.9997	0.9997	0.9997	0.9997	0.9970	0.9970	0.9712
17	0.9997	0.9997	0.9997	0.9997	0.9971	0.9971	0.9720
18	0.9998	0.9998	0.9998	0.9998	0.9971	0.9971	0.9728
19	0.9998	0.9998	0.9998	0.9998	0.9971	0.9971	0.9736
20	0.9998	0.9998	0.9998	0.9998	0.9971	0.9971	0.9744
21	0.9998	0.9998	0.9998	0.9998	0.9971	0.9971	0.9752
22	0.9999	0.9999	0.9999	0.9999	0.9972	0.9972	0.9760
23	0.9999	0.9999	0.9999	0.9999	0.9972	0.9972	0.9768
24	0.9999	0.9999	0.9999	0.9999	0.9972	0.9972	0.9776
25	0.9999	0.9999	0.9999	0.9999	0.9973	0.9973	0.9784
26	1.0000	1.0000	1.0000	1.0000	0.9973	0.9973	0.9792
27	1.0000	1.0000	1.0000	1.0000	0.9973	0.9973	0.9800
Temperature	#1 Diesel	Jet-A	Jet A-1	JP-8	#2 Diesel	JP-5	#4 Diesel

°C	Resolution Factor						
28	1.0000	1.0000	1.0000	1.0000	0.9974	0.9974	0.9808
29	1.0000	1.0000	1.0000	1.0000	0.9974	0.9974	0.9816
30	1.0000	1.0000	1.0000	1.0000	0.9975	0.9975	0.9824
31	1.0000	1.0000	1.0000	1.0000	0.9976	0.9976	0.9832
32	1.0000	1.0000	1.0000	1.0000	0.9977	0.9977	0.9840
33	1.0000	1.0000	1.0000	1.0000	0.9978	0.9978	0.9848
34	1.0000	1.0000	1.0000	1.0000	0.9980	0.9980	0.9856
35	1.0000	1.0000	1.0000	1.0000	0.9981	0.9981	0.9864
36	1.0000	1.0000	1.0000	1.0000	0.9982	0.9982	0.9872
37	1.0000	1.0000	1.0000	1.0000	0.9983	0.9983	0.9880
38	1.0000	1.0000	1.0000	1.0000	0.9985	0.9985	0.9888
39	1.0000	1.0000	1.0000	1.0000	0.9985	0.9985	0.9896
40	1.0000	1.0000	1.0000	1.0000	0.9986	0.9986	0.9904
41	1.0000	1.0000	1.0000	1.0000	0.9987	0.9987	0.9907
42	1.0000	1.0000	1.0000	1.0000	0.9987	0.9987	0.9910
43	1.0000	1.0000	1.0000	1.0000	0.9987	0.9987	0.9912
44	1.0000	1.0000	1.0000	1.0000	0.9987	0.9987	0.9915
45	1.0000	1.0000	1.0000	1.0000	0.9987	0.9987	0.9918
46	1.0000	1.0000	1.0000	1.0000	0.9987	0.9987	0.9920
47	1.0000	1.0000	1.0000	1.0000	0.9988	0.9988	0.9923
48	1.0000	1.0000	1.0000	1.0000	0.9988	0.9988	0.9925
49	1.0000	1.0000	1.0000	1.0000	0.9988	0.9988	0.9927
50	1.0000	1.0000	1.0000	1.0000	0.9988	0.9988	0.9929
51	1.0000	1.0000	1.0000	1.0000	0.9989	0.9989	0.9930
52	1.0000	1.0000	1.0000	1.0000	0.9989	0.9989	0.9931
53	1.0000	1.0000	1.0000	1.0000	0.9990	0.9990	0.9932
54	1.0000	1.0000	1.0000	1.0000	0.9990	0.9990	0.9933
55	1.0000	1.0000	1.0000	1.0000	0.9991	0.9991	0.9934
56	1.0000	1.0000	1.0000	1.0000	0.9992	0.9992	0.9934
57	1.0000	1.0000	1.0000	1.0000	0.9992	0.9992	0.9935
58	1.0000	1.0000	1.0000	1.0000	0.9993	0.9993	0.9936
59	1.0000	1.0000	1.0000	1.0000	0.9994	0.9994	0.9938
60	1.0000	1.0000	1.0000	1.0000	0.9994	0.9994	0.9940
61	1.0000	1.0000	1.0000	1.0000	0.9995	0.9995	0.9944
62	1.0000	1.0000	1.0000	1.0000	0.9995	0.9995	0.9949
63	1.0000	1.0000	1.0000	1.0000	0.9996	0.9996	0.9955
64	1.0000	1.0000	1.0000	1.0000	0.9996	0.9996	0.9961
65	1.0000	1.0000	1.0000	1.0000	0.9996	0.9996	0.9967
66	1.0000	1.0000	1.0000	1.0000	0.9997	0.9997	0.9973
67	1.0000	1.0000	1.0000	1.0000	0.9997	0.9997	0.9980
68	1.0000	1.0000	1.0000	1.0000	0.9997	0.9997	0.9987
69	1.0000	1.0000	1.0000	1.0000	0.9998	0.9998	0.9990
70	1.0000	1.0000	1.0000	1.0000	0.9998	0.9998	1.0000

Correction factors are based on this group of hydrocarbons.

**TEMPERATURE COMPENSATION TABLES
ARE NOT REQUIRED FOR 6" METERS
BETWEEN -32°C AND 70°C**

APPENDIX D METER KIT DIAGRAMS

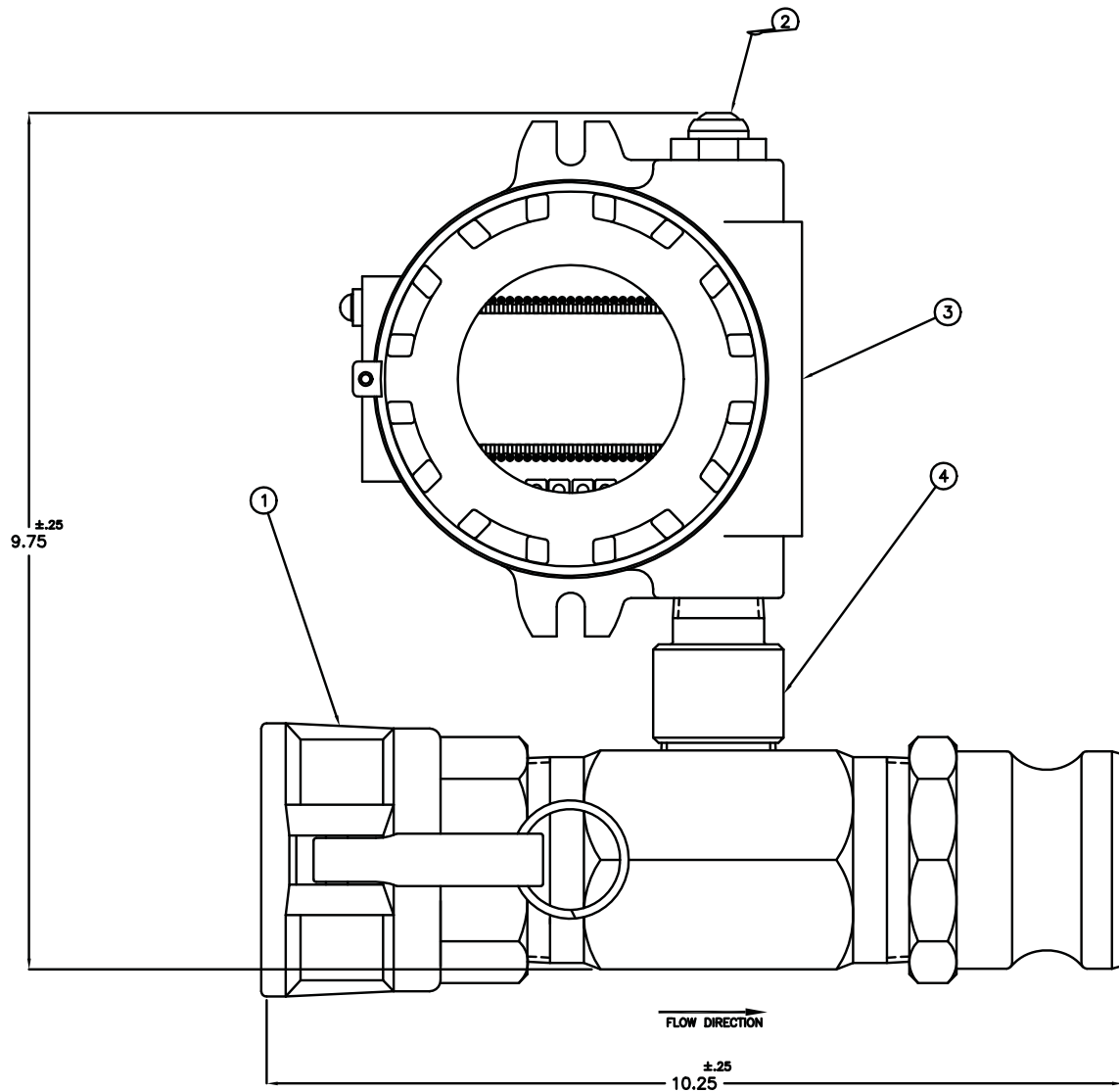

#	Part Number	Part Description	Quantity
1	C-LB45-A006-MIL	Meter, Turbine, 2"	1
2	C-LB85-Reset Switch	Reset Switch	1
3	EIH21 MF	Enclosure Assembly	1
4	BX240657	Reducer, Bell, 3/4" Male x 1" Female	1
5*	BX222121	Wire Harness	1

* Part Not Shown

Fig. 15 Kit, fuel pumping 2"

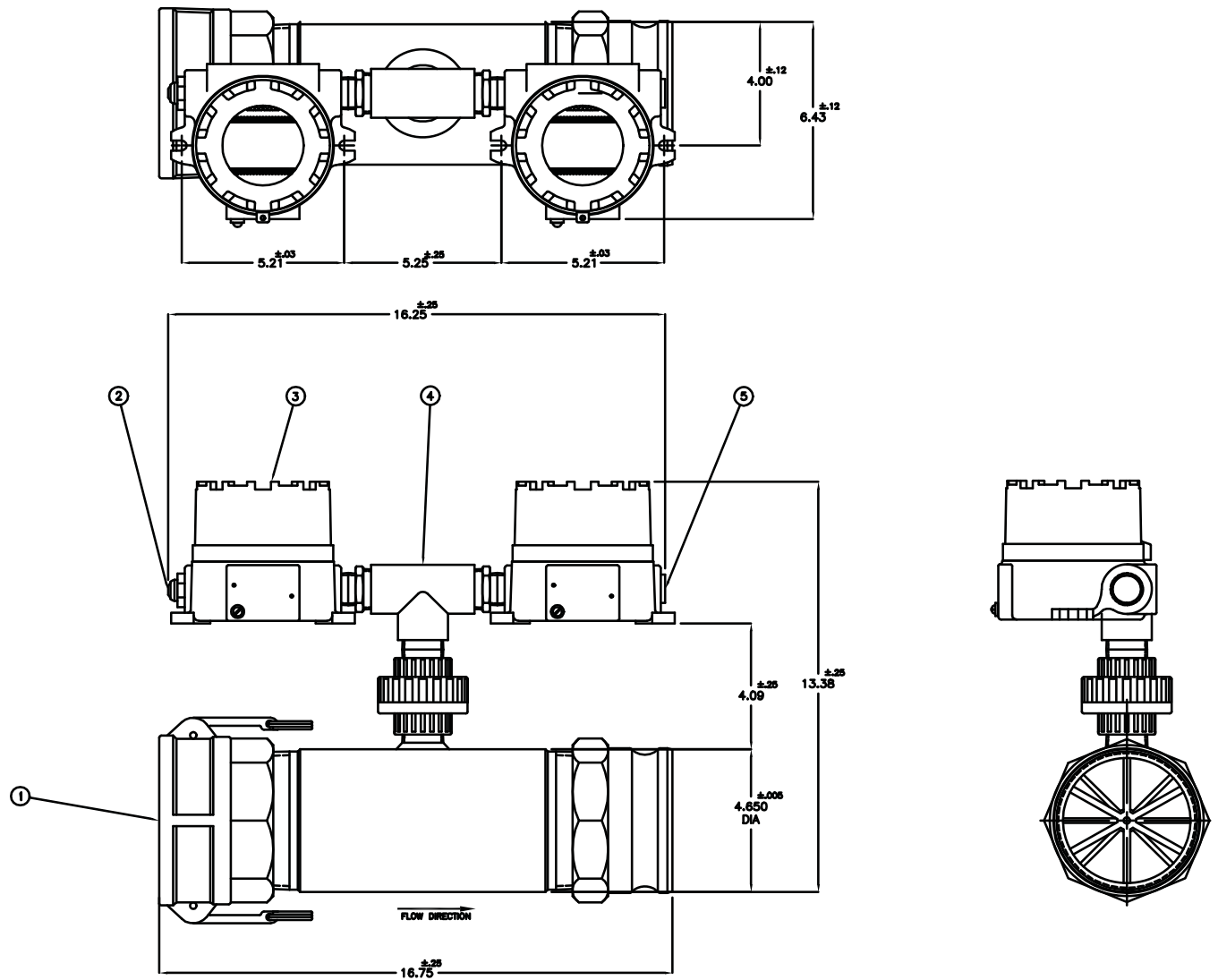

#	Part Number	Part Description	Quantity
1	C-LB45-A009-MIL	Meter, Turbine, 4"	1
2	C-LB85-Reset Switch	Reset Switch	1
3	C-LB45-C005-MIL	Monitor, B2800; ADV,BP,XP,EXT,OP,TEMP	2
4	BX311-095-MIL	Aluminum Assembly Tee	1
5	BX118236	3/4" NPT Male Plug, Aluminum	1
6*	BX311-089	Wire Harness, Dual Monitor	1

* Part Not Shown

Fig. 16 Kit, fuel pumping 4"

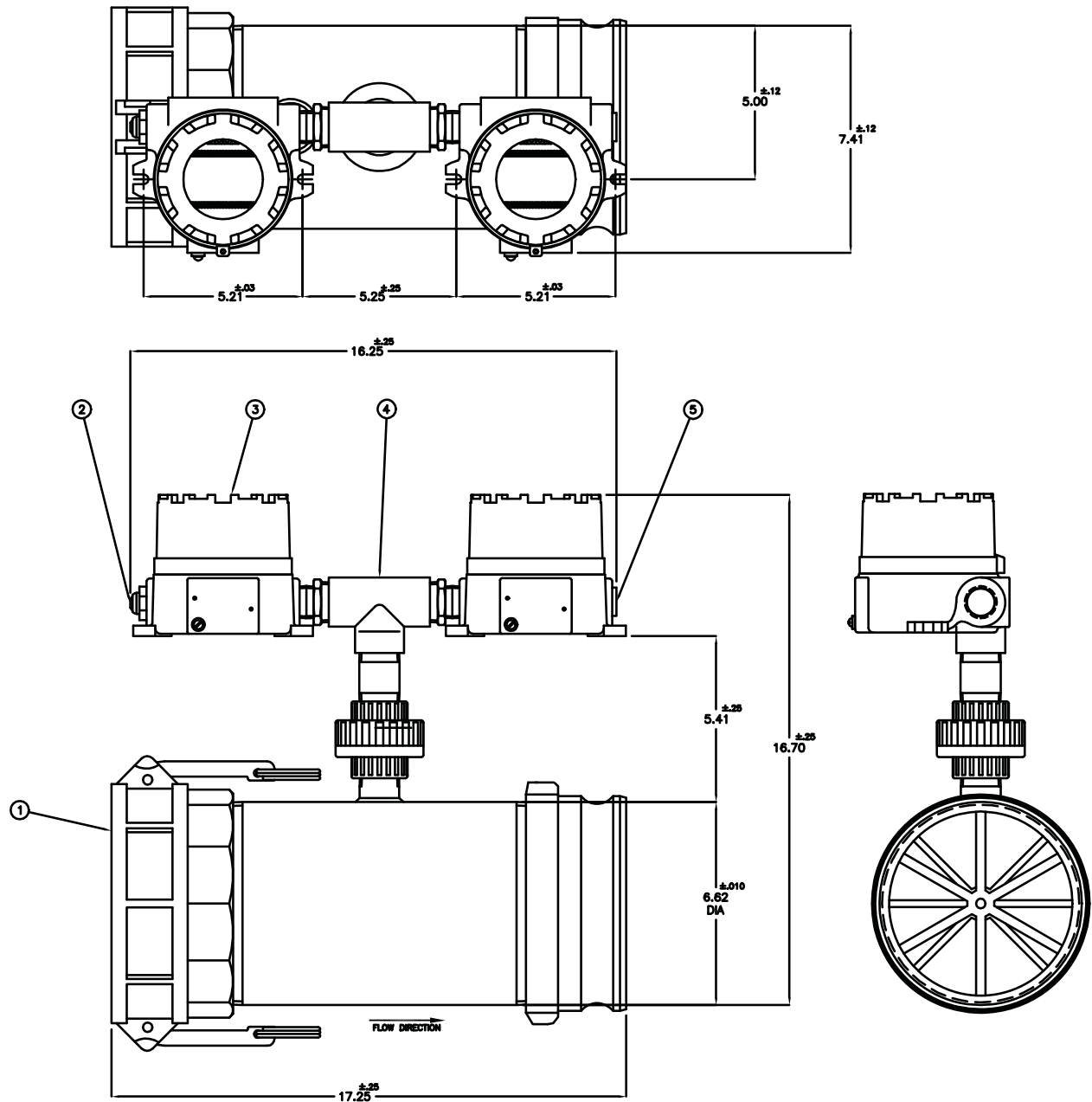

#	Part Number	Part Description	Quantity
1	C-LB45-A010-MIL	Meter, Turbine, 6"	1
2	C-LB85-Reset Switch	Reset Switch	1
3	C-LB45-C005-MIL	Monitor, B2800; ADV,BP,XP,EXT,OP,TEMP	2
4	BX311-095-MIL	Aluminum Assembly Tee	1
5	BX118236	3/4" NPT Male Plug, Aluminum	1
6*	BX311-089	Wire Harness, Dual Monitor	1

* Part Not Shown

Fig. 17 Kit, fuel pumping 6"

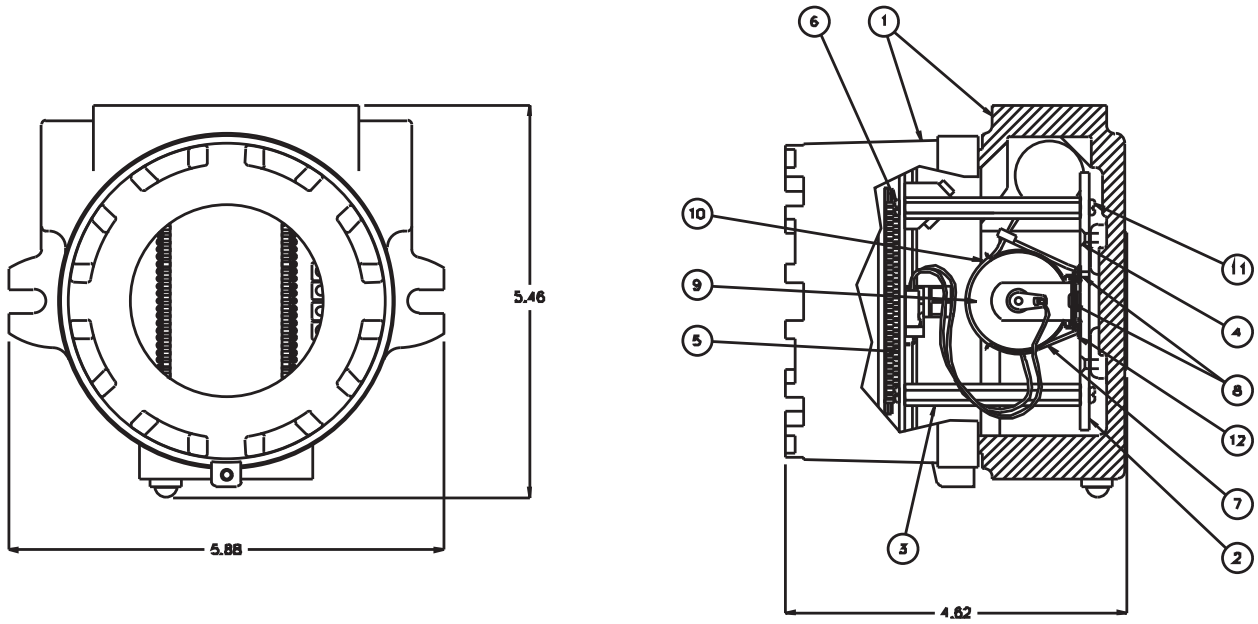

#	Part Number	Part Description	Quantity
1	EIH21 MF	Enclosure Assembly	1
2	BX280618	Battery Support Plate	1
3	BX280667	Standoff, #4-40X2-1/4"; Female-female	4
4	BX280620	Screw, Flat Head #4-40X3/8"; 18-8	4
5	C-LB80-280691	PCB Assembly; Bat Pwr, Ext. Range	1
6	BX280623	Screw, Pan Head #4-40X3/16"; 18-8	4
7	BX280634	Battery Bracket Assembly, D-Cell	1
8	BX280678	Screw, Flat Head, #4-40X3/16"; Zinc	4
9	TL-2300	Battery, Lithium D Cell	1
10	BX228036	Cable Tie	1
11	BX220328	Screw, Pan Head 4-40X3/8", 18-8	4
12	BX280677	Adapter/Bridge Plate	1
13*	BX220141	Desiccant bag	1

* Part Not Shown

Fig. 18 Monitor

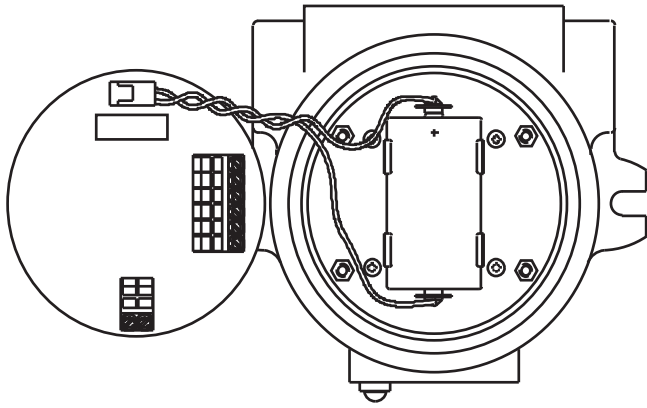

VIEW WITH PCB SCREWS
REMOVED AND PCB REMOVED

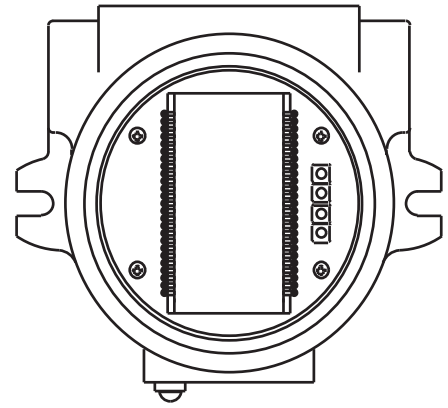

VIEW WITH ENCLOSURE
COVER REMOVED

Fig. 19 Monitor, cover removed



Contact Info

Instrumart

35 Green Mountain Drive

S Burlington, VT 05403

888-FLOW-888

www.instrumart.com