



## OPTIFLUX 6000 Handbook

Electromagnetic flow sensor  
for hygienic and sanitary applications

The documentation is only complete when used in combination with the relevant documentation for the signal converter.

All rights reserved. It is prohibited to reproduce this documentation, or any part thereof, without the prior written authorisation of KROHNE Messtechnik GmbH.

Subject to change without notice.

Copyright 2019 by  
KROHNE Messtechnik GmbH - Ludwig-Krohne-Str. 5 - 47058 Duisburg (Germany)

<b>1</b>	<b>Safety instructions</b>	<b>5</b>
<hr/>		
1.1	Intended Use .....	5
1.2	Certification .....	5
1.3	Safety instructions from the manufacturer .....	6
1.3.1	Copyright and data protection .....	6
1.3.2	Disclaimer .....	6
1.3.3	Product liability and warranty .....	7
1.3.4	Information concerning the documentation .....	7
1.3.5	Warnings and symbols used .....	8
1.4	Safety instructions for the operator .....	8
<b>2</b>	<b>Device description</b>	<b>9</b>
<hr/>		
2.1	Scope of delivery .....	9
2.2	Device description .....	10
2.3	Nameplates (examples) .....	11
<b>3</b>	<b>Installation</b>	<b>12</b>
<hr/>		
3.1	General notes on installation .....	12
3.2	Storage .....	12
3.3	Transport .....	12
3.4	Pre-installation requirements .....	13
3.5	General requirements .....	13
3.5.1	Vibration .....	13
3.5.2	Magnetic field .....	13
3.6	Installation conditions .....	14
3.6.1	Inlet and outlet .....	14
3.6.2	Bends in 2 or 3 dimensions .....	14
3.6.3	T-section .....	15
3.6.4	Bends .....	15
3.6.5	Open discharge .....	16
3.6.6	Control valve .....	16
3.6.7	Pump .....	16
3.6.8	Air venting and vacuum forces .....	17
3.6.9	Mounting requirements for self-draining .....	18
3.6.10	Flange deviation .....	19
3.6.11	Mounting position .....	19
3.7	Mounting .....	20
3.7.1	Torques and pressures .....	20
3.7.2	Installation of weld-on versions .....	21
<b>4</b>	<b>Electrical connections</b>	<b>22</b>
<hr/>		
4.1	Safety instructions .....	22
4.2	Grounding .....	22
4.3	Virtual reference for IFC 300 ( C, W and F version) .....	23
4.4	Connection diagrams .....	23

5 Service	24
<hr/>	
5.1 Cleaning .....	24
5.2 Spare parts availability .....	24
5.3 Availability of services .....	24
5.4 Returning the device to the manufacturer .....	24
5.4.1 General information .....	24
5.4.2 Form (for copying) to accompany a returned device .....	25
5.5 Disposal .....	25
5.5.1 Disassembling and recycling .....	25
6 Technical data	26
<hr/>	
6.1 Measuring principle .....	26
6.2 Technical data .....	27
6.3 Measuring accuracy .....	31
6.4 Dimensions and weights .....	33
7 Notes	47
<hr/>	

## 1.1 Intended Use

**CAUTION!**

*Responsibility for the use of the measuring devices with regard to suitability, intended use and corrosion resistance of the used materials against the measured fluid lies solely with the operator.*

**INFORMATION!**

*The manufacturer is not liable for any damage resulting from improper use or use for other than the intended purpose.*

The OPTIFLUX 6000 is designed to measure the volumetric flowrate of electrically conductive fluids in hygienic applications.

## 1.2 Certification

CE marking



The manufacturer certifies successful testing of the product by applying the CE marking.

**This device fulfils the statutory requirements of the relevant EU directives.**

For full information of the EU directives and standards and the approved certifications, please refer to the EU Declaration of Conformity or the website of the manufacturer.

**Other approvals and standards**

- Measuring Instruments Directive 2014/32/EU, Annex III (MI-001), Annex VII (MI-005)

For more information, please refer to the dedicated documentation.

**DANGER!**

*For devices used in hazardous areas, additional safety notes apply. Please refer to the Ex documentation.*

## 1.3 Safety instructions from the manufacturer

### 1.3.1 Copyright and data protection

The contents of this document have been created with great care. Nevertheless, we provide no guarantee that the contents are correct, complete or up-to-date.

The contents and works in this document are subject to copyright. Contributions from third parties are identified as such. Reproduction, processing, dissemination and any type of use beyond what is permitted under copyright requires written authorisation from the respective author and/or the manufacturer.

The manufacturer tries always to observe the copyrights of others, and to draw on works created in-house or works in the public domain.

The collection of personal data (such as names, street addresses or e-mail addresses) in the manufacturer's documents is always on a voluntary basis whenever possible. Whenever feasible, it is always possible to make use of the offerings and services without providing any personal data.

We draw your attention to the fact that data transmission over the Internet (e.g. when communicating by e-mail) may involve gaps in security. It is not possible to protect such data completely against access by third parties.

We hereby expressly prohibit the use of the contact data published as part of our duty to publish an imprint for the purpose of sending us any advertising or informational materials that we have not expressly requested.

### 1.3.2 Disclaimer

The manufacturer will not be liable for any damage of any kind by using its product, including, but not limited to direct, indirect or incidental and consequential damages.

This disclaimer does not apply in case the manufacturer has acted on purpose or with gross negligence. In the event any applicable law does not allow such limitations on implied warranties or the exclusion of limitation of certain damages, you may, if such law applies to you, not be subject to some or all of the above disclaimer, exclusions or limitations.

Any product purchased from the manufacturer is warranted in accordance with the relevant product documentation and our Terms and Conditions of Sale.

The manufacturer reserves the right to alter the content of its documents, including this disclaimer in any way, at any time, for any reason, without prior notification, and will not be liable in any way for possible consequences of such changes.

### 1.3.3 Product liability and warranty

The operator shall bear responsibility for the suitability of the device for the specific purpose. The manufacturer accepts no liability for the consequences of misuse by the operator. Improper installation or operation of the devices (systems) will cause the warranty to be void. The respective "Standard Terms and Conditions" which form the basis for the sales contract shall also apply.

### 1.3.4 Information concerning the documentation

To prevent any injury to the user or damage to the device it is essential that you read the information in this document and observe applicable national standards, safety requirements and accident prevention regulations.

If this document is not in your native language and if you have any problems understanding the text, we advise you to contact your local office for assistance. The manufacturer can not accept responsibility for any damage or injury caused by misunderstanding of the information in this document.

This document is provided to help you establish operating conditions, which will permit safe and efficient use of this device. Special considerations and precautions are also described in the document, which appear in the form of icons as shown below.

### 1.3.5 Warnings and symbols used

Safety warnings are indicated by the following symbols.



**DANGER!**

*This warning refers to the immediate danger when working with electricity.*



**DANGER!**

*This warning refers to the immediate danger of burns caused by heat or hot surfaces.*



**DANGER!**

*This warning refers to the immediate danger when using this device in a hazardous atmosphere.*



**DANGER!**

*These warnings must be observed without fail. Even partial disregard of this warning can lead to serious health problems and even death. There is also the risk of seriously damaging the device or parts of the operator's plant.*



**WARNING!**

*Disregarding this safety warning, even if only in part, poses the risk of serious health problems. There is also the risk of damaging the device or parts of the operator's plant.*



**CAUTION!**

*Disregarding these instructions can result in damage to the device or to parts of the operator's plant.*



**INFORMATION!**

*These instructions contain important information for the handling of the device.*



**LEGAL NOTICE!**

*This note contains information on statutory directives and standards.*



• **HANDLING**

This symbol designates all instructions for actions to be carried out by the operator in the specified sequence.

➔ **RESULT**

This symbol refers to all important consequences of the previous actions.

## 1.4 Safety instructions for the operator



**WARNING!**

*In general, devices from the manufacturer may only be installed, commissioned, operated and maintained by properly trained and authorized personnel.  
This document is provided to help you establish operating conditions, which will permit safe and efficient use of this device.*



## 2.1 Scope of delivery

**INFORMATION!**

Inspect the packaging carefully for damages or signs of rough handling. Report damage to the carrier and to the local office of the manufacturer.

**INFORMATION!**

Do a check of the packing list to make sure that you have all the elements given in the order.

**INFORMATION!**

The remote version will arrive in two cartons. One carton contains the converter and one carton contains the sensor.



Figure 2-1: Scope of delivery

- ① Ordered flowmeter
- ② Product documentation
- ③ Factory calibration report
- ④ Signal cable (remote version only)

**INFORMATION!**

Assembly materials and tools are not part of the delivery. Use the assembly materials and tools in compliance with the applicable occupational health and safety directives.

## 2.2 Device description

Your measuring device is supplied ready for operation. The factory settings for the operating data have been made in accordance with your order specifications.



### INFORMATION!

Product specific information and extensive product specification is available using PICK, the Product Information Center KROHNE web-tool.

PICK can be found via the service menu button on the KROHNE.com website.



### The following versions are available:

- Compact version (the signal converter is installed directly on the measuring sensor)
- Remote version (electrical connection to the signal converter via field current and signal cable)



### INFORMATION!

This flow sensor can be used as a remote version or as a compact version. All versions are covered by this document, although you will see the remote version in most pictures.

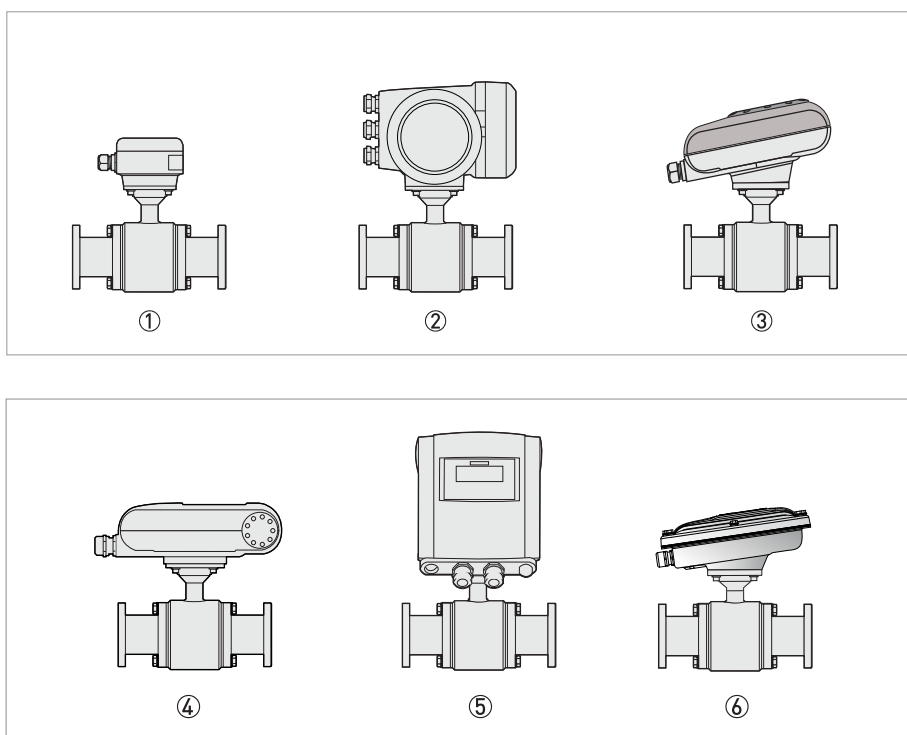

Figure 2-2: Available versions

- ① Remote version
- ② Compact version with IFC 300 signal converter
- ③ Compact version with IFC 050 (10°) signal converter
- ④ Compact version with IFC 100 (0°) signal converter
- ⑤ Compact version with IFC 100 (45°) signal converter
- ⑥ Compact version with IFC 100 stainless steel signal converter (10°)

## 2.3 Nameplates (examples)



### INFORMATION!

Look at the device nameplate to ensure that the device is delivered according to your order. Check for the correct supply voltage printed on the nameplate.

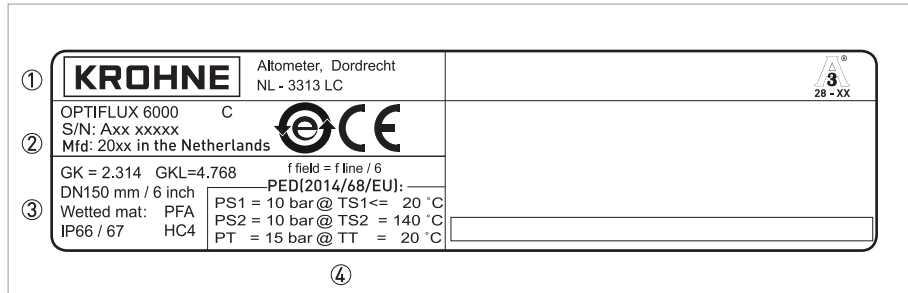

Figure 2-3: Example of a nameplate on a sensor

- ① Name and address of the manufacturer
- ② Type designation of the flowmeter and CE sign with number(s) of notified body / bodies
- ③ Calibration data
- ④ PED data Calibration data and protection category

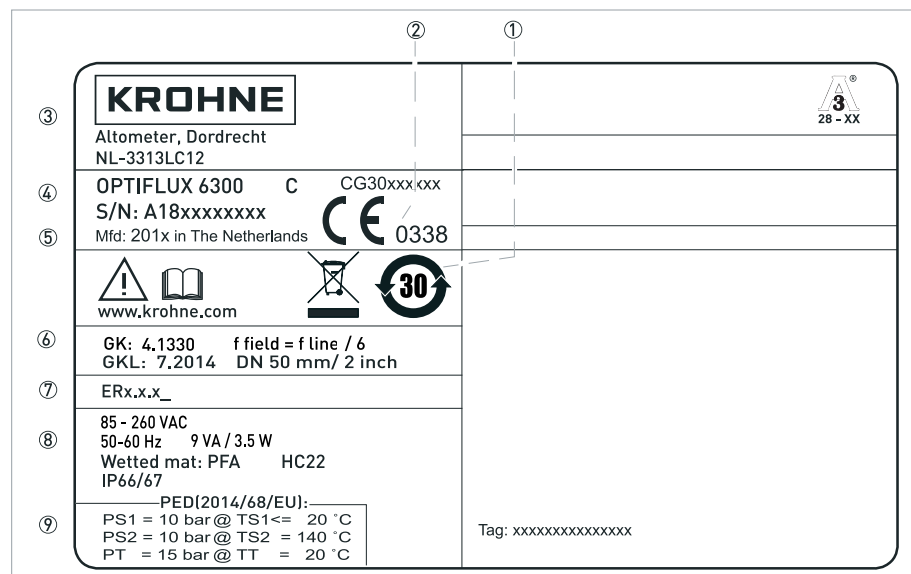

Figure 2-4: Example of a nameplate for a compact version

- ① Additional info, website and recycling logo
- ② CE marking with number(s) of notified body (bodies)
- ③ Name and address of manufacturer
- ④ Type designation with serial / CG number
- ⑤ Manufacturing date and country of origin
- ⑥ GK/GKL values (measuring sensor constants), size (mm/inches), field frequency
- ⑦ Electronic Revision number
- ⑧ Electric values, protection category and materials of wetted parts
- ⑨ PED data type I/II/III or SEP

### 3.1 General notes on installation



**INFORMATION!**

Inspect the packaging carefully for damages or signs of rough handling. Report damage to the carrier and to the local office of the manufacturer.



**INFORMATION!**

Do a check of the packing list to make sure that you have all the elements given in the order.



**INFORMATION!**

Look at the device nameplate to ensure that the device is delivered according to your order. Check for the correct supply voltage printed on the nameplate.

### 3.2 Storage

- Store the device in a dry and dust-free location.
- Avoid lasting direct exposure to the sun.
- Store the device in its original packaging.
- Storage temperature: -50...+70°C / -58...+158°F

### 3.3 Transport

#### Signal converter

- No special requirements.

#### Compact version

- Do not lift the device by the signal converter housing.
- Do not use lifting chains.
- To transport flange devices, use lifting straps. Wrap these around both process connections.

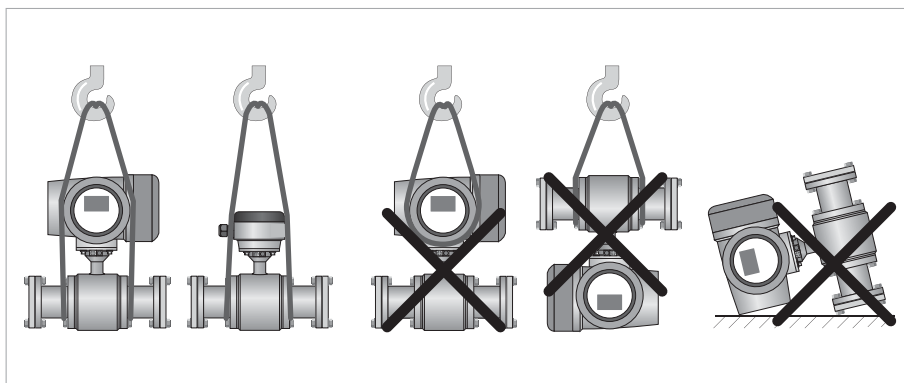

Figure 3-1: Transport

### 3.4 Pre-installation requirements

Make sure that you have all necessary tools available:

- Allen key (4 mm)
- Small screwdriver
- Wrench for cable glands
- Wrench for wall mounting bracket (remote version only)
- Torque wrench for installing flowmeter in pipeline

### 3.5 General requirements



**INFORMATION!**

The following precautions must be taken to ensure reliable installation.

- Make sure that there is adequate space to the sides.
- Protect the signal converter from direct sunlight and install a sun shade if necessary.
- Signal converters installed in control cabinets require adequate cooling, e.g. by fan or heat exchanger.
- Do not expose the signal converter to intense vibration. The flowmeters are tested for a vibration level in accordance with IEC 60068-2-64.

#### 3.5.1 Vibration

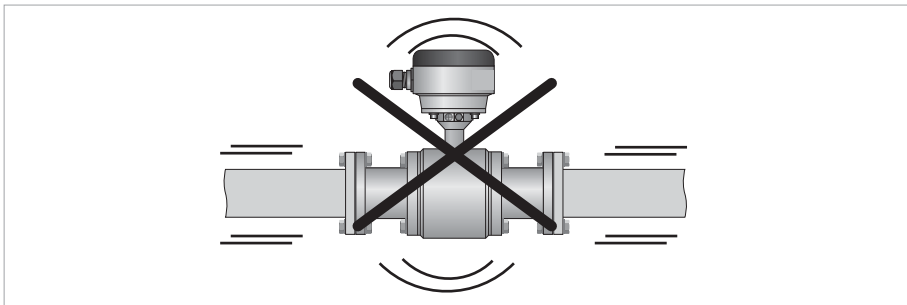

Figure 3-2: Avoid vibrations

#### 3.5.2 Magnetic field

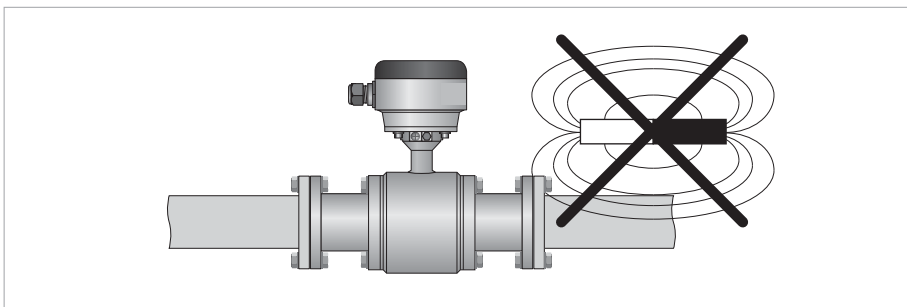

Figure 3-3: Avoid magnetic fields

## 3.6 Installation conditions

### 3.6.1 Inlet and outlet

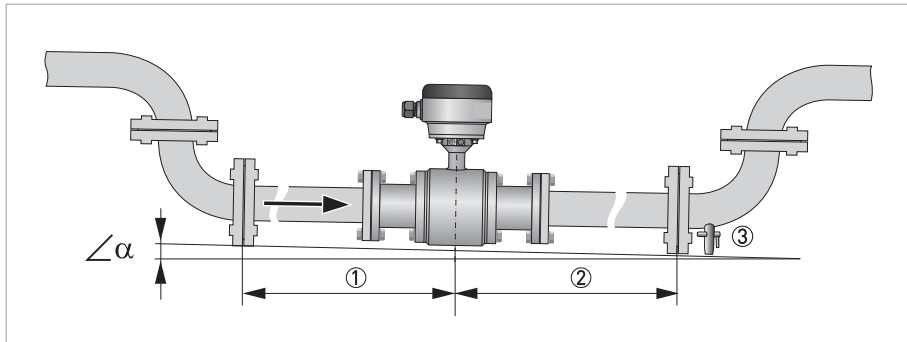

Figure 3-4: Recommended inlet and outlet

- ① Refer to chapter "Bends in 2 or 3 dimensions"
- ②  $\geq 2$  DN
- ③ Drain valve (to empty pipeline)
- $\angle \alpha ; > 2^\circ$

### 3.6.2 Bends in 2 or 3 dimensions

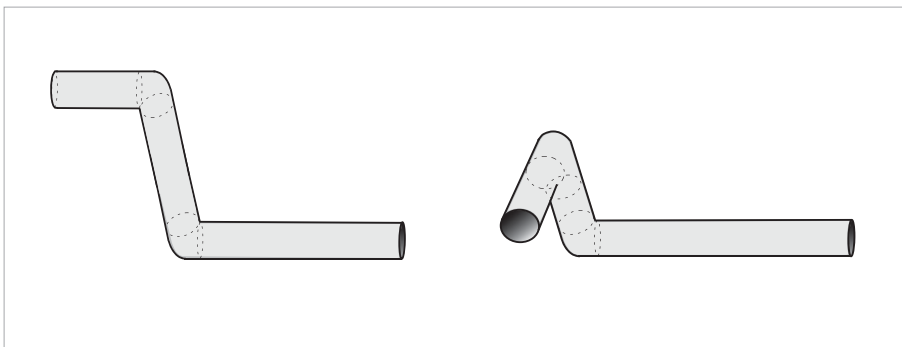

Figure 3-5: Inlet when using 2 and/or 3 dimensional bends upstream of the flowmeter

Inlet length: using bends in 2 dimensions:  $\geq 5$  DN; when having bends in 3 dimensions:  $\geq 10$  DN



**INFORMATION!**

*2 Dimensional bends occur in a vertical **or** horizontal plane only, while 3 Dimensional bends occur in both vertical **and** horizontal plane.*

### 3.6.3 T-section

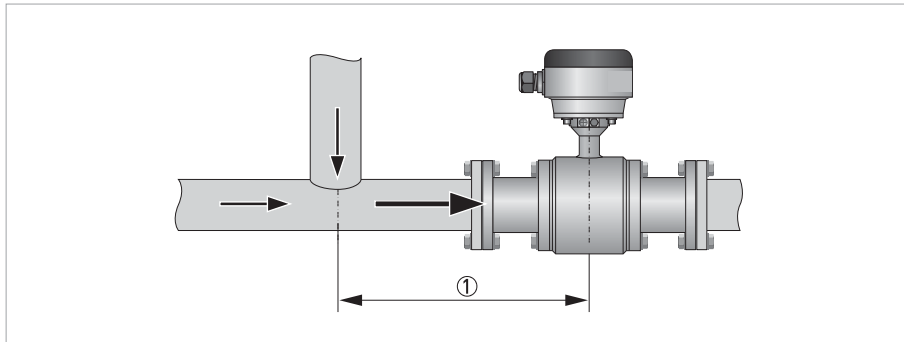

Figure 3-6: Distance behind a T-section

①  $\geq 10 \text{ DN}$

### 3.6.4 Bends

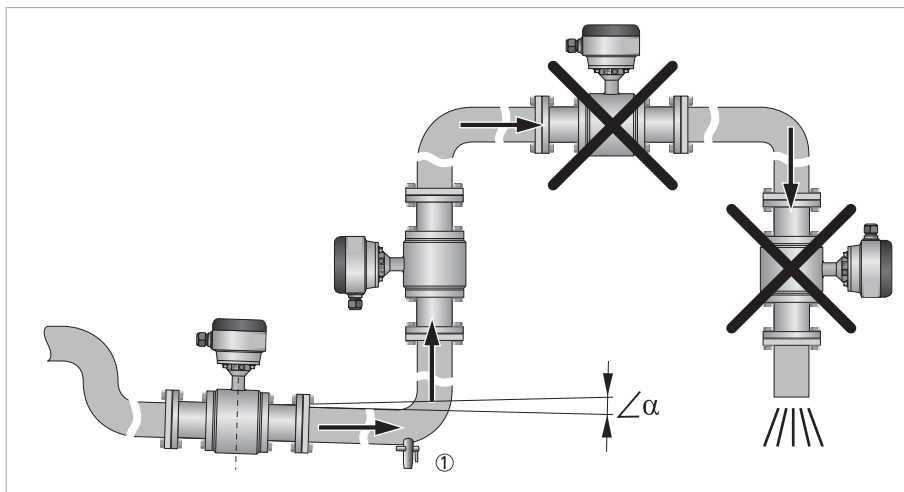

Figure 3-7: Installation in bending pipes

$\angle \alpha ; > 2^\circ$

① Drain valve (to empty pipeline)

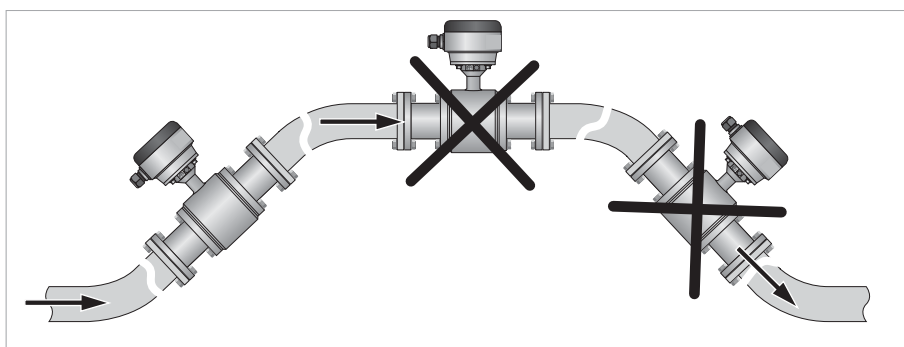

Figure 3-8: Installation in bending pipes

3.6.5 Open discharge

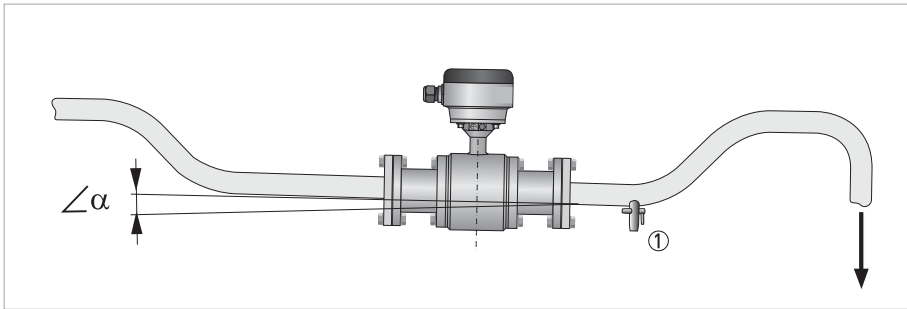

Figure 3-9: Installation in front of an open discharge

$\angle\alpha ; >2^\circ$

① Drain valve (to empty pipeline)

3.6.6 Control valve

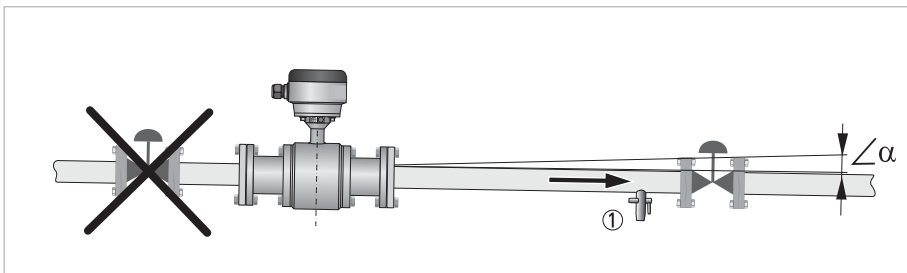

Figure 3-10: Installation in front of a control valve

$\angle\alpha ; >2^\circ$

① Drain valve (to empty pipeline)

3.6.7 Pump

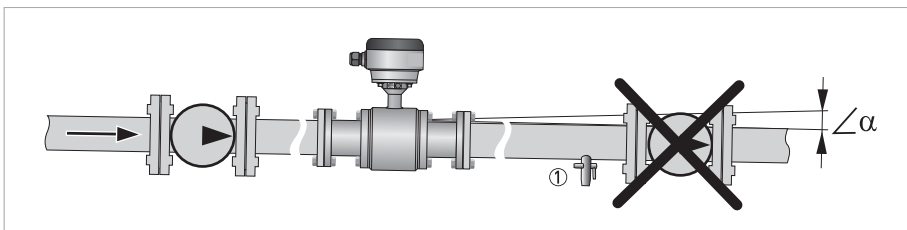

Figure 3-11: Installation behind a pump



### 3.6.8 Air venting and vacuum forces

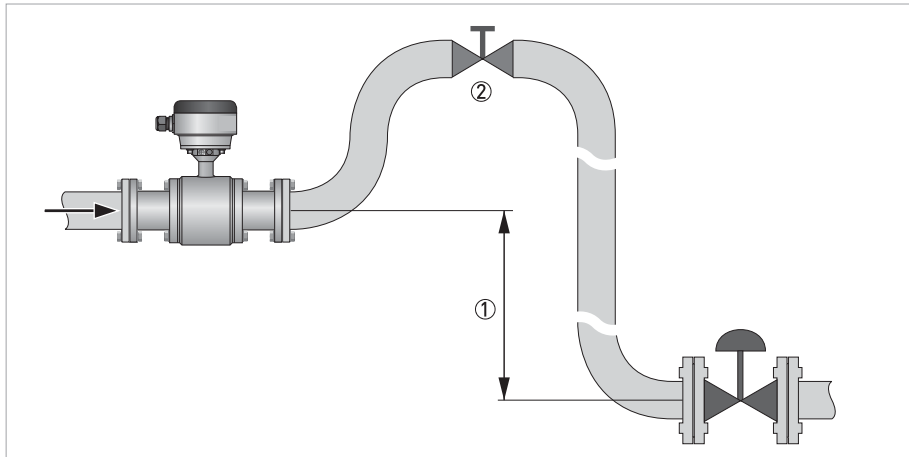

Figure 3-12: Air venting

- ①  $\geq 5$  m
- ② Air ventilation point

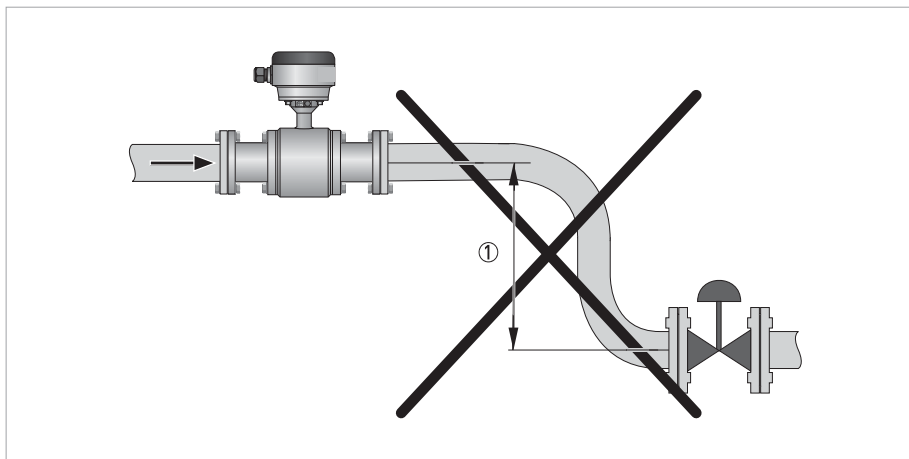

Figure 3-13: Vacuum

- ①  $\geq 5$  m

### 3.6.9 Mounting requirements for self-draining



**INFORMATION!**

Applicable for 3A marked installations: install flow sensor in vertical pipelines or in pipelines with a minimum slope as indicated!

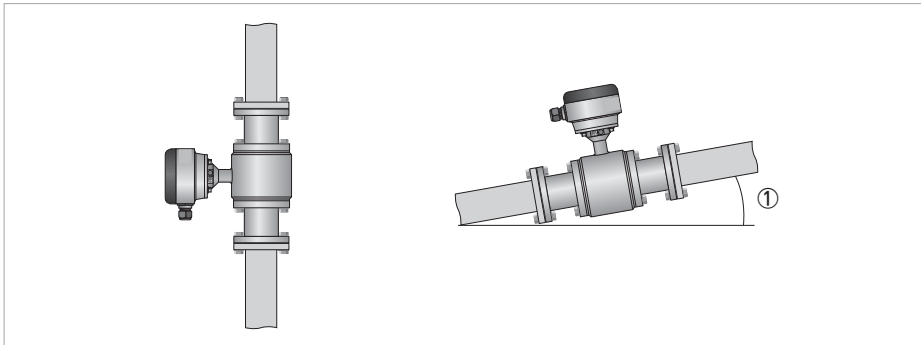

Figure 3-14: Installation note for 3A marked installations

① Minimum slope

#### Minimum slope

Nominal diameter	DIN 11850	ISO 2037	DIN 11864 2A	ISO 2852	DIN 32676	Tri Clamp
2.5...6	10°	10°	-	-	-	-
10	3°	3°	-	-	-	-
15	10°	10°	-	①	-	-
25	10°	3°	10°	3°	10°	3°
40...50	5°	3°	5°	3°	5°	3°
65...80	10°	3°	10°	3°	10°	3°
100	5°	3°	5°	3°	5°	3°
125...150	10°	3°	10°	3°	①	①

① on request

### 3.6.10 Flange deviation

**CAUTION!**

Max. permissible deviation of pipe flange faces:

$$L_{max} - L_{min} \leq 0.5 \text{ mm} / 0.02''$$

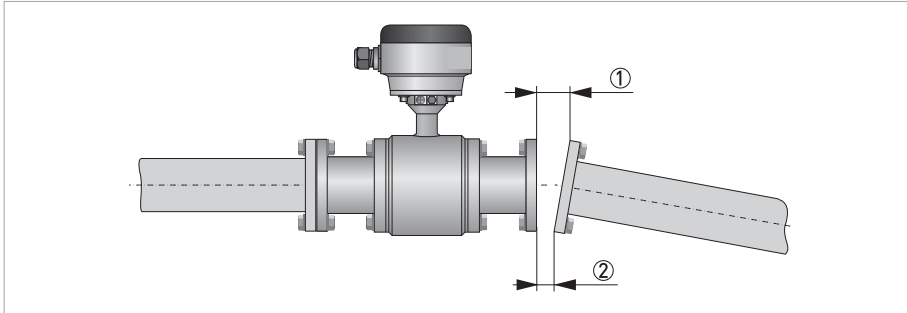

Figure 3-15: Flange deviation

- ①  $L_{max}$
- ②  $L_{min}$

### 3.6.11 Mounting position

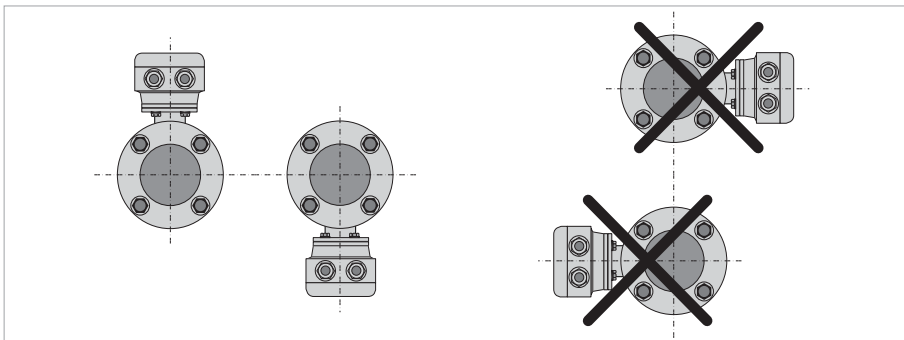

Figure 3-16: Mounting position

- Install flow sensor in line with the pipe axis.
- Pipe flange faces must be parallel to each other.

## 3.7 Mounting

### 3.7.1 Torques and pressures

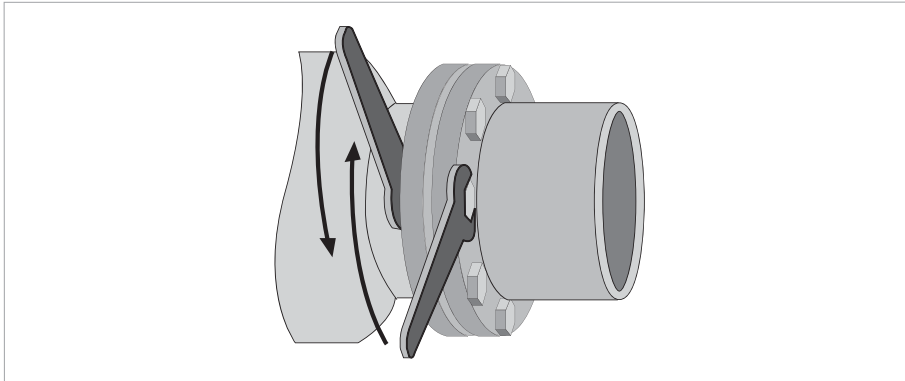

Figure 3-17: Tightening of bolts



**CAUTION!**

The max. allowable torque depends on the gasket material, see datasheet for detailed information. Bolts to be used from material SS, class 70-A2.



**Tightening of bolts**

- Always tighten the bolts uniformly and in diagonally opposite sequence.
- Do not exceed the maximum torque value.
- Step 1: Apply approx. 50% of max. torque given in table.
- Step 2: Apply approx. 80% of max. torque given in table.
- Step 3: Apply 100% of max. torque given in table.

**Maximum torque for 11864-2A flange version**

Nominal diameter [mm]	Pressure rating	Bolts	Max. torque [Nm]
25	PN 40	4x M6	7
40	PN 40	4x M8	16
50	PN 25	4x M8	16
80	PN 25	6x M8	16
100	PN 25	6x M8	16
125	PN 10	6x M10	32
150	PN 10	6x M10	32



**INFORMATION!**

Maximum torque for sizes smaller than DN25: 6 Nm

### 3.7.2 Installation of weld-on versions

For mounting sensors with weld-on connections, please follow the procedure as follows:



- Mount the sensor completely in the pipeline and spot the weld-on connections to the pipe. This is necessary to align the mounting bores of the flange.
- Remove the sensor body and the gaskets from the adapters by loosen the screws.
- Weld the adapters completely to the pipe.
- When the pipe is cold again, reinstall the gasket and mount the sensor.

## 4.1 Safety instructions

**DANGER!**

All work on the electrical connections may only be carried out with the power disconnected. Take note of the voltage data on the nameplate!

**DANGER!**

Observe the national regulations for electrical installations!

**DANGER!**

For devices used in hazardous areas, additional safety notes apply; please refer to the Ex documentation.

**WARNING!**

Observe without fail the local occupational health and safety regulations. Any work done on the electrical components of the measuring device may only be carried out by properly trained specialists.

**INFORMATION!**

Look at the device nameplate to ensure that the device is delivered according to your order. Check for the correct supply voltage printed on the nameplate.

## 4.2 Grounding

**DANGER!**

The device must be grounded in accordance with regulations in order to protect personnel against electric shocks.

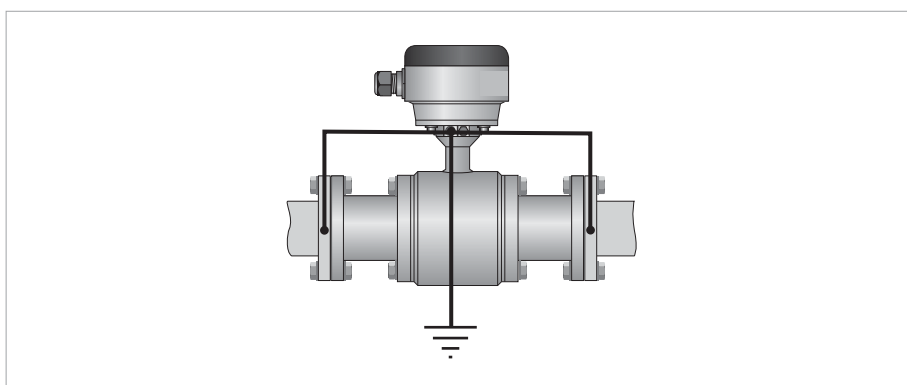

Figure 4-1: Grounding

### 4.3 Virtual reference for IFC 300 ( C, W and F version)

#### Benefits of virtual reference:

- Grounding rings or grounding electrodes can be omitted.
- Safety increases by reducing the number of potential leakage points.
- The installation of the flowmeters is much easier.

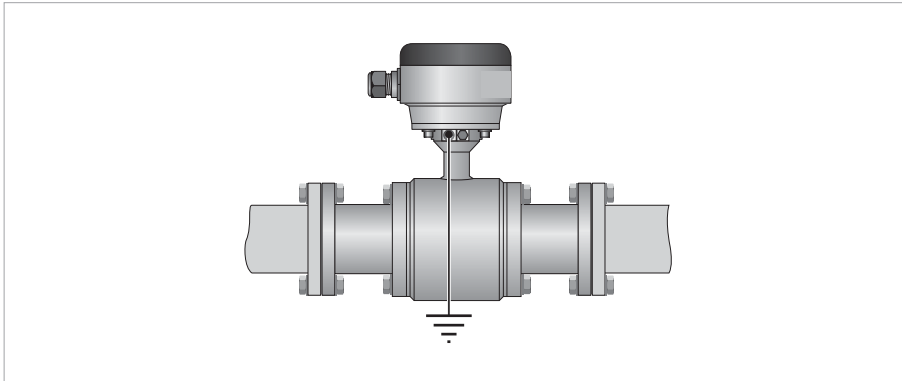

Figure 4-2: Virtual reference

#### Minimum requirements:

- Size:  $\geq$  DN10 / 3/8"
- Electrical conductivity:  $\geq$  200  $\mu$ S/cm
- Electrode cable: max. 50 m / 164 ft, type DS

### 4.4 Connection diagrams



#### **INFORMATION!**

*For the connection diagrams the documentation of the applicable signal converter.*

## 5.1 Cleaning

**CAUTION!**

*In principle, no special maintenance is needed. However, make sure that the used cleaning product doesn't affect the outer surface and the gaskets.*

## 5.2 Spare parts availability

The manufacturer adheres to the basic principle that functionally adequate spare parts for each device or each important accessory part will be kept available for a period of 3 years after delivery of the last production run for the device.

This regulation only applies to spare parts which are subject to wear and tear under normal operating conditions.

## 5.3 Availability of services

The manufacturer offers a range of services to support the customer after expiration of the warranty. These include repair, maintenance, technical support and training.

**INFORMATION!**

*For more precise information, please contact your local sales office.*

## 5.4 Returning the device to the manufacturer

### 5.4.1 General information

This device has been carefully manufactured and tested. If installed and operated in accordance with these operating instructions, it will rarely present any problems.

**WARNING!**

*Should you nevertheless need to return a device for inspection or repair, please pay strict attention to the following points:*

- *Due to statutory regulations on environmental protection and safeguarding the health and safety of the personnel, the manufacturer may only handle, test and repair returned devices that have been in contact with products without risk to personnel and environment.*
- *This means that the manufacturer can only service this device if it is accompanied by the following certificate (see next section) confirming that the device is safe to handle.*

**WARNING!**

*If the device has been operated with toxic, caustic, radioactive, flammable or water-endangering products, you are kindly requested:*

- *to check and ensure, if necessary by rinsing or neutralising, that all cavities are free from such dangerous substances,*
- *to enclose a certificate with the device confirming that it is safe to handle and stating the product used.*



### 5.4.2 Form (for copying) to accompany a returned device



**CAUTION!**

*To avoid any risk for our service personnel, this form has to be accessible from outside of the packaging with the returned device.*

Company:		Address:	
Department:		Name:	
Tel. no.:		Fax no. and/or Email address:	
Manufacturer's order no. or serial no.:			
The device has been operated with the following medium:			
This medium is:	<input type="checkbox"/>	radioactive	
	<input type="checkbox"/>	water-hazardous	
	<input type="checkbox"/>	toxic	
	<input type="checkbox"/>	caustic	
	<input type="checkbox"/>	flammable	
	<input type="checkbox"/>	We checked that all cavities in the device are free from such substances.	
<input type="checkbox"/>	We have flushed out and neutralized all cavities in the device.		
We hereby confirm that there is no risk to persons or the environment through any residual media contained in the device when it is returned.			
Date:		Signature:	
Stamp:			

## 5.5 Disposal



**LEGAL NOTICE!**

*Disposal must be carried out in accordance with legislation applicable in your country.*

**Separate collection of WEEE (Waste Electrical and Electronic Equipment) in the European Union:**



According to the directive 2012/19/EU, the monitoring and control instruments marked with the WEEE symbol and reaching their end-of-life **must not be disposed of with other waste**.

The user must dispose of the WEEE to a designated collection point for the recycling of WEEE or send them back to our local organisation or authorised representative.

### 5.5.1 Disassembling and recycling



**INFORMATION!**

*For information about disassembling and recycling, refer to the applicable documentation of the measuring converter or consult product support for the product recycling passport.*

## 6.1 Measuring principle

An electrically conductive fluid flows inside an electrically insulated pipe through a magnetic field. This magnetic field is generated by a current, flowing through a pair of field coils.

Inside of the fluid, a voltage  $U$  is generated:

$$U = v * k * B * D$$

in which:

$v$  = mean flow velocity

$k$  = factor correcting for geometry

$B$  = magnetic field strength

$D$  = inner diameter of flowmeter

The signal voltage  $U$  is picked off by electrodes and is proportional to the mean flow velocity  $v$  and thus the flow rate  $Q$ . A signal converter is used to amplify the signal voltage, filter it and convert it into signals for totalizing, recording and output processing.

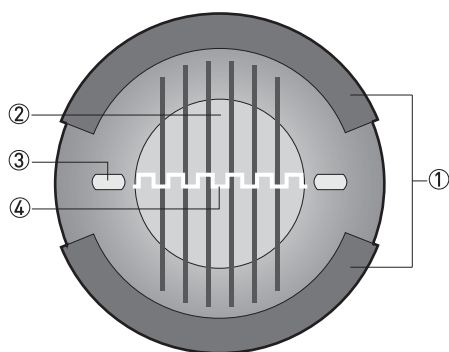

Figure 6-1: Measuring principle

- ① Field coils
- ② Magnetic field
- ③ Electrodes
- ④ Induced voltage (proportional to flow velocity)

## 6.2 Technical data



### INFORMATION!

- The following data is provided for general applications. If you require data that is more relevant to your specific application, please contact us or your local sales office.
- Additional information (certificates, special tools, software,...) and complete product documentation can be downloaded free of charge from the website (Downloadcenter).

### Measuring system

Measuring principle	Faraday's law of induction
Application range	Electrically conductive fluids
<b>Measured value</b>	
Primary measured value	Flow velocity
Secondary measured value	Volume flow

### Design

Features	Hygienic design
	Stainless steel housing
	Food & beverage and pharmaceutical process connections
Modular construction	The measurement system consists of a flow sensor and a signal converter. It is available as compact and as separate version.
Compact version	With IFC 050 signal converter: OPTIFLUX 6050 C
	With IFC 100 signal converter: OPTIFLUX 6100 C
	With IFC 300 signal converter: OPTIFLUX 6300 C
Remote version	In wall (W) mount version with IFC 050 signal converter: OPTIFLUX 6050 W
	In wall (W) mount version with IFC 100signal converter: OPTIFLUX 6100 W
	In field (F), wall (W) or rack (R) mount version with IFC 300 signal converter: OPTIFLUX 6300 F, W or R
Nominal diameter	DN2.5...150 / 1/10"...6"
Measuring range	-12...+12 m/s / -40...+40 ft/s

### Measuring accuracy

Maximum measuring error	Depending on signal converter and DN size.
	IFC 050: down to 0.5% of the measured value $\pm 1$ mm/s.
	IFC 100: down to 0.3% of the measured value $\pm 1$ mm/s for DN10...150 (3/8...6"). down to 0.4% of the measured value $\pm 1$ mm/s for DN2.5...6 (1/10...1/4").
	IFC 300: down to 0.2% of the measured value $\pm 1$ mm/s for DN10...150 (3/8...6"). down to 0.3% of the measured value $\pm 2$ mm/s for DN2.5...6 (1/10...1/4").
	<b>Optional:</b>
	Optimised accuracy for IFC 050 and IFC 100. For more details on optimised accuracy, see the concerning signal converter documentation.
	The additional typical measuring deviation for the current output is $\pm 10$ $\mu$ A.
	The maximum measuring error depends on the installation conditions. For detailed information refer to <i>Measuring accuracy</i> on page 31.
Repeatability	$\pm 0.1\%$ of MV, minimum 1 mm/s

Long term stability	±0.1% of MV
Special calibration	On request

### Operating conditions

<b>Temperature</b>	
Process temperature	Separate flow sensor: -40...+140°C / -40...+284°F
	Compact with IFC 300 converter: -40...+140°C / -40...+284°F
	Compact with IFC 050 and IFC 100 converter: -40...+120°C / -40...+248°F at an ambient temperature ≤ 40 °C / 104 °F
	For ISO 2852 and Tri-clamp versions: -40...+120°C / -40...+248°F
	For Ex versions different temperatures are valid. Please check the relevant Ex documentation for details.
Ambient temperature	-40...+65°C / -40...+149°F
	IFC 100 stainless steel version: -40...+60°C / -40...+140°F
Storage temperature	-50...+70°C / -58...+158°F
<b>Pressure</b>	
Ambient pressure	Atmospheric
Nominal flange pressure	For detailed information refer to <i>Dimensions and weights</i> on page 33.
Vacuum load	0 mbar / 0 psi
<b>Chemical properties</b>	
Physical condition	Electrical conductive liquids
Electrical conductivity	Standard: ≥ 1 μS/cm
	Water: ≥ 20 μS/cm
Permissible gas content (volume)	IFC 050: ≤ 3%
	IFC 100: ≤ 3%
	IFC 300: ≤ 5%
Permissible solid content (volume)	IFC 050: ≤ 10%
	IFC 100: ≤ 10%
	IFC 300: ≤ 70%

### Installation conditions

Installation	Assure that the flow sensor is always fully filled.
	For detailed information refer to <i>Installation</i> on page 12.
Flow direction	Forward and reverse
	Arrow on flow sensor indicates positive flow direction.
Inlet run	≥ 5 DN
Outlet run	≥ 2 DN
Dimensions and weights	For detailed information refer to <i>Dimensions and weights</i> on page 33.

## Materials

Sensor housing	DN2.5...15: stainless steel Duplex (1.4462)
	DN25...150: stainless steel AISI 304 (1.4301)
Measuring tube	Stainless steel AISI 304 (1.4301)
Adapters	Stainless steel AISI 316 L (1.4404)
	Other materials on request.
Liner	PFA
Connection box (F-version only)	<b>Standard:</b> Aluminum with a standard coating
	<b>Option:</b> Stainless steel AISI (1.4408)
Electrodes	<b>Standard:</b> Hastelloy <sup>®</sup> C
	<b>Option:</b> Hastelloy <sup>®</sup> B2, platinum, stainless steel, tantalum, titanium
Gaskets	<b>Standard:</b> EPDM
	FDA recommends EPDM gaskets only if medium ≤ 8% fat.
	<b>Option:</b> Silicone (non-Ex only)

## Process connections

DIN 11850 row 2 / 11866 row A	DN2.5...150
DIN 11851	DN2.5...150
DIN 11864-2A flange with notch	DN25...150
DIN 32676	DN25...150
ISO 2037	DN2.5...150
ISO 2852	DN2.5...150
SMS 1146	DN2.5...100
Tri Clamp	1/10" ...6"
Note: sensor diameters < DN10 have DN10 connections, which means the sensor diameter is smaller.	

## Electrical connections

<b>Signal cable</b>	
Type A (DS)	Standard cable, double shielded. Max. length: 600 m / 1950 ft (dep. on electrical conductivity and measuring sensor). See documentation of the converter for more information.
Type B (BTS)	Optional cable, triple shielded. Max. length: 600 m / 1950 ft (dep. on electrical conductivity and measuring sensor). See documentation of the converter for more information.

## Approvals and certificates

<b>CE</b>	
This device fulfills the statutory requirements of the EU directives. The manufacturer certifies successful testing of the product by applying the CE mark.	
	For full information of the EU directives and standards and the approved certifications, please refer to the EU Declaration of Conformity or the website of the manufacturer.
<b>Hazardous areas</b>	
ATEX	Please check the relevant Ex documentation for details.
	<b>Compact version with IFC 300 C converter:</b>
	II 2 G, II D, II 2 (1) G
	<b>Remote (F) version:</b>
	II 2 G, II 2 D
FM	<b>In combination with IFC 300 C or F converter:</b>
	Class I, Div. 2, Groups A, B, C and D
	Class II, Div. 2, Groups F and G
	Class III, Div. 2, Groups F and G
	Only available for DN2.5...15
CSA	<b>In combination with IFC 300 C or F converter:</b>
	Class I, Div. 2, Groups A, B, C and D
	Class II, Div. 2, Groups F and G
	Class III, Div. 2, Groups F and G
	Only available for DN2.5...15
<b>Other approvals and standards</b>	
Protection category acc. to IEC/EN 60529	<b>Standard</b>
	IP 66/67 (NEMA 4/4X/6)
	<b>Option (F version only)</b>
	IP 68 field (NEMA 6P)
	IP 68 factory (NEMA 6P)
	IP 68 is only available for separate design and with a stainless steel connection box.
<b>Option IP69</b>	
IP 67/69 is available for connection box and IFC 100 in stainless steel.	
Hygienic	3A approved
	EHEDG
Shock test	IEC 60068-2-27
	30 g for 18 ms
Vibration test	IEC 60068-2-64
	f = 20...2000 Hz, rms = 4.5 g, t = 30 min.

### 6.3 Measuring accuracy

Every electromagnetic flowmeter is calibrated by direct volume comparison. The wet calibration validates the performance of the flowmeter under reference conditions against accuracy limits.

The accuracy limits of electromagnetic flowmeters are typically the result of the combined effect of linearity, zero point stability and calibration uncertainty.

#### Reference conditions

- Medium: water
- Temperature: +5...35°C / +41...95°F
- Operating pressure: 0.1...5 barg / 1.5...72.5 psig
- Inlet section:  $\geq 5$  DN
- Outlet section:  $\geq 2$  DN

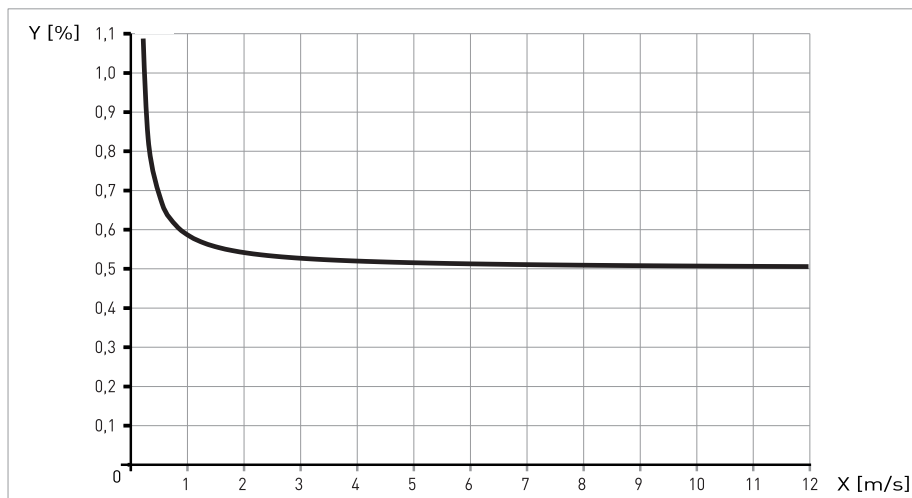

Figure 6-2: Flow velocity vs. accuracy  
 X [m/s] : flow velocity  
 Y [%]: deviation from the actual measured value (mv)

Compact with IFC 050	Accuracy	Curve
DN10...150 / 3/8...6"	0.5% of MV + 1 mm/s	



#### INFORMATION!

Optionally for IFC 050; extended calibration at 2 points for optimised accuracy.  
 For more details on optimised accuracy, see the concerning signal converter documentation.

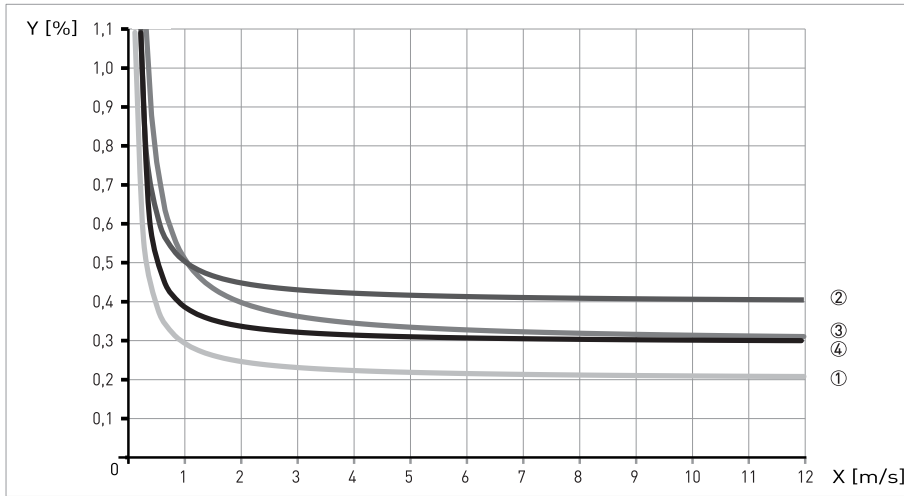

Figure 6-3: Flow velocity vs. accuracy  
 X [m/s] : flow velocity  
 Y [%]: deviation from the actual measured value (mv)

Compact with IFC 300	Accuracy	Curve
DN2.5...6 / 1/10...1/4"	0.3% of MV + 2 mm/s	③
DN10...150 / 3/8...6"	0.2% of MV + 1 mm/s	①

Compact with IFC 100	Accuracy	Curve
DN2.5...6 / 1/10...1/4"	0.4% of MV + 1 mm/s	②
DN10...150 / 3/8...6"	0.3% of MV + 1 mm/s	④



**INFORMATION!**

Optionally for IFC 100; extended calibration at 2 points for optimised accuracy.  
 For more details on optimised accuracy, see the concerning signal converter documentation.



## 6.4 Dimensions and weights

DIN 11850 (row 2 or DIN 11866 row A)

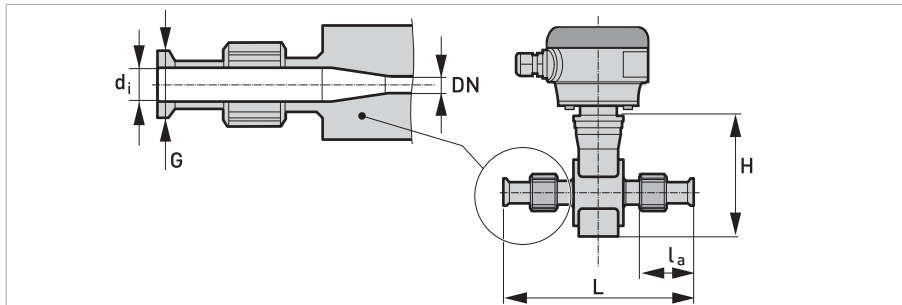

DN2.5...10 screwed adapter with DN10 process connections / DN15 screwed adapter

Nominal size		Dimensions [mm]						Approx. weight
		Adapter			Flowmeter			
DN	PN	$d_i$	G	$l_a$	L	H	W	[kg]
2.5...10	40	10	13	32	180	120	44	1.5
15	40	16	19	32	180	120	44	1.5

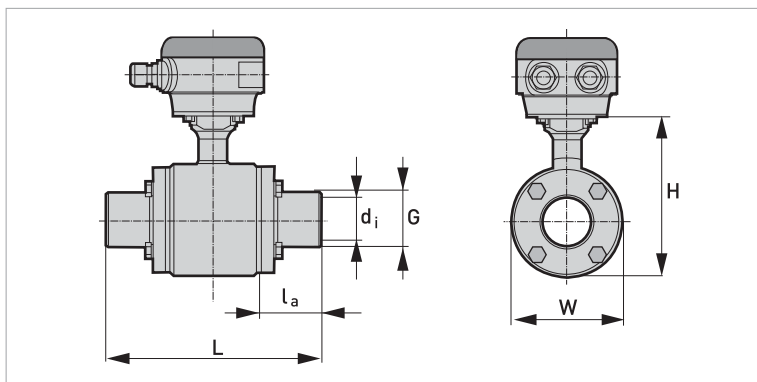

DN25...150 bolted adapter

Nominal size		Dimensions [mm]						Approx. weight
		Adapter			Flowmeter			
DN	PN	$d_i$	G	$l_a$	L	H	W	[kg]
25	40	26	29	20.6	132.6	128	89	3
40	40	38	41	61.3	220	153	114	5.3
50	25	50	53	61.3	220	153	114	6.8
65	25	66	70	41.8	220	180	141	10.9
80	25	81	85	66.8	280	191	152	11.2
100	16	100	104	59.3	280	242	203	18.4
125	10	125	129	66.3	319	258	219	29.5
150	10	150	154	64.3	325	293	254	44.3

## DIN 11851

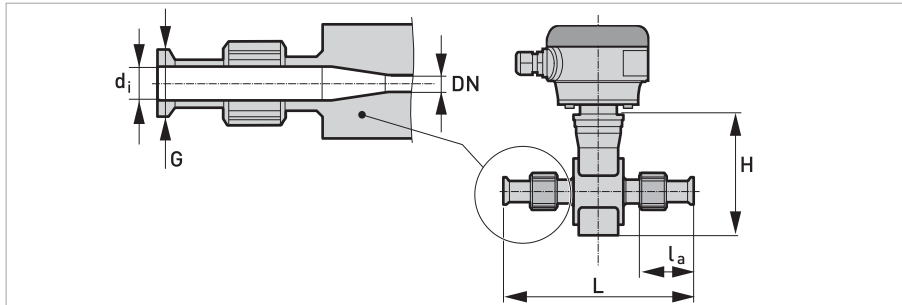

DN2.5...10 screwed adapter with DN10 process connections / DN15 screwed adapter

Nominal size		Dimensions [mm]						Approx. weight [kg]
		Adapter			Flowmeter			
DN	PN	d <sub>i</sub>	G	l <sub>a</sub>	L	H	W	
2.5...10	40	10	Rd 28 x 1/8"	53.1	214	142	44	1.5
15	40	16	Rd 34 x 1/8"	53.1	214	142	44	1.5

## DIN 11851

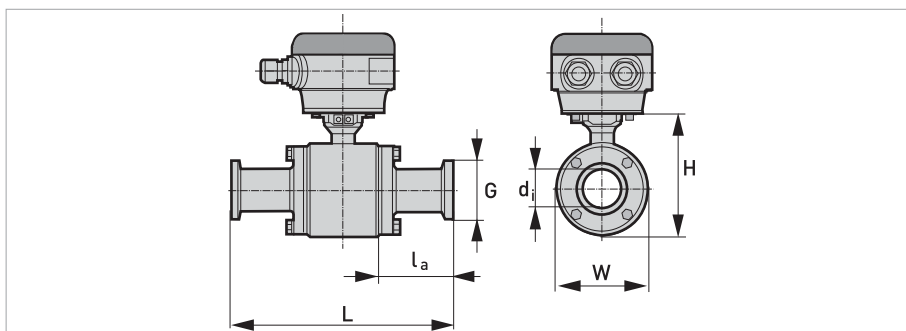

DN25...150 bolted adapter

Nominal size		Dimensions [mm]						Approx. weight [kg]
		Adapter			Flowmeter			
DN	PN	$d_i$	G	$l_a$	L	H	W	
25	40	26	Rd 52 x 1/6"	49.3	190	128	89	3.2
40	40	38	Rd 65 x 1/6"	91.3	280	153	114	5.5
50	25	50	Rd 78 x 1/6"	93.3	284	153	114	5.3
65	25	66	Rd 95 x 1/6"	77.8	292	180	141	10
80	25	81	Rd 110 x 1/4"	107.8	362	191	152	12.5
100	16	100	Rd 130 x 1/4"	109.3	380	242	203	21.8
125	10	On request						
150	10	On request						

## DIN 11864-2A

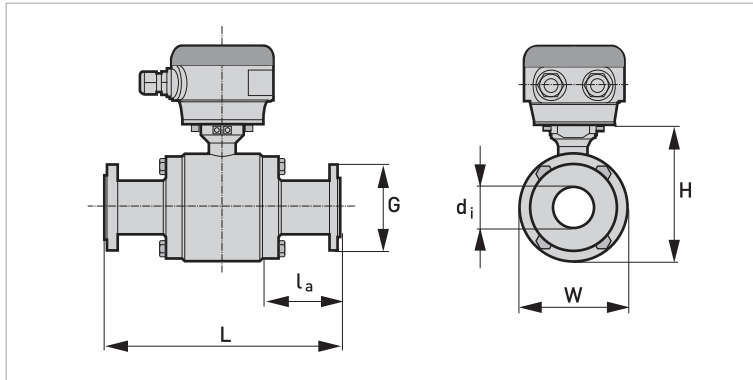

DN25...150 bolted adapter

Nominal size		Dimensions [mm]						Approx. weight [kg]
		Adapter			Flowmeter			
DN	PN	d <sub>i</sub>	G	l <sub>a</sub>	L	H	W	
25	40	26	70	45.8	183	128	89	4.4
40	25	38	82	83.3	264	153	114	7.5
50	25	50	94	83.3	264	153	114	9
65	25	66	113	63.8	264	180	141	14.5
80	25	81	133	122.8	392	191	152	18.6
100	16	100	159	115.3	392	242	203	28.2
125	10	125	183	121	429	259	219	35
150	10	150	213	127	450	294	254	52

## DIN 32676

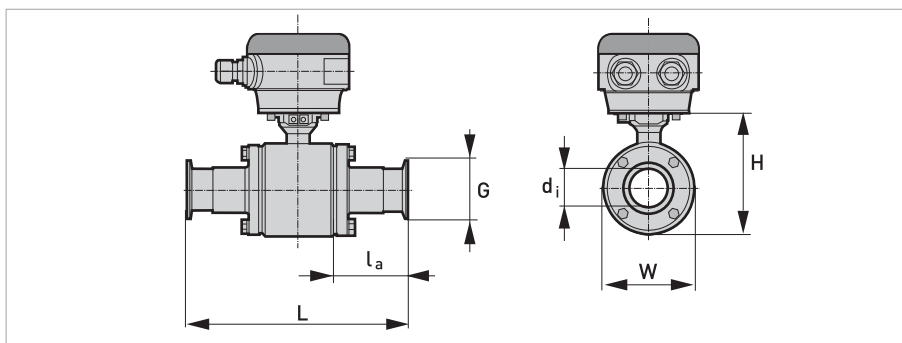

DN25...150 bolted adapter

Nominal size		Dimensions [mm]						Approx. weight
		Adapter			Flowmeter			
DN	PN	$d_i$	G	$l_a$	L	H	W	[kg]
25	16	26	50.5	41.8	175	128	89	3.2
40	16	38	50.5	80.8	259	153	114	5.5
50	16	50	64	80.8	259	153	114	5.3
65	16	66	91	67.8	272	180	141	10
80	16	81	106	92.8	332	191	152	12.5
100	16	100	119	85.3	332	242	203	21.8
125	16	125	155	90	366	259	219	30
150	16	150	213	127	450	294	254	45

## ISO 2037

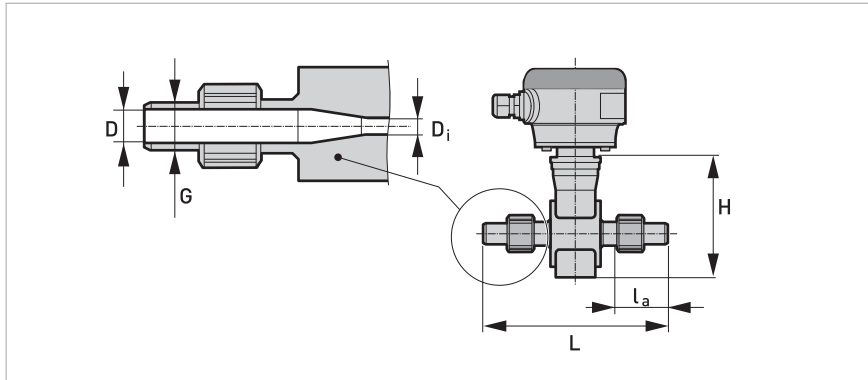

DN2.5...10 screwed adapter with DN10 process connections / DN17.2 screwed adapter

Nominal size		Dimensions [mm]						Approx. weights
		Adapter			Flowmeter			
DN	PN	$d_i$	G	$l_a$	L	H	W	[kg]
2.5...12	40	10	15	32	180	142	44	1.5
17.2	40	16	21	32	180	142	44	1.5

ISO 2037

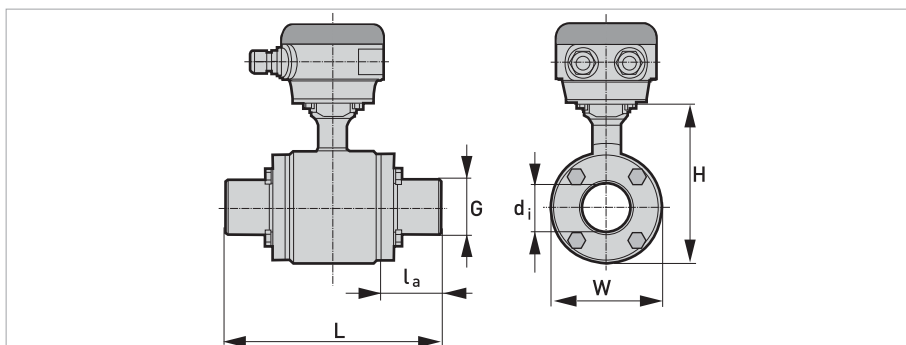

DN25...150 bolted adapter

Nominal size		Dimensions [mm]						Approx. weights [kg]
		Adapter			Flowmeter			
DN	PN	$d_i$	G	$l_a$	L	H	W	
25	40	22.6	31	20.6	132.6	128	89	3
38	40	38	43	61.3	220	153	114	5.3
51	25	49	55	61.3	220	153	114	5
63.5	25	60.3	71	41.8	220	180	141	9
76.1	25	72.9	86	66.8	280	191	152	10.8
101.6	16	97.6	105	59.3	280	242	203	18.4
114.3	10	110.3	130	66.3	319	258	219	29.5
139.7	10	135.7	156	64.3	325	293	254	44.3



## ISO 2852

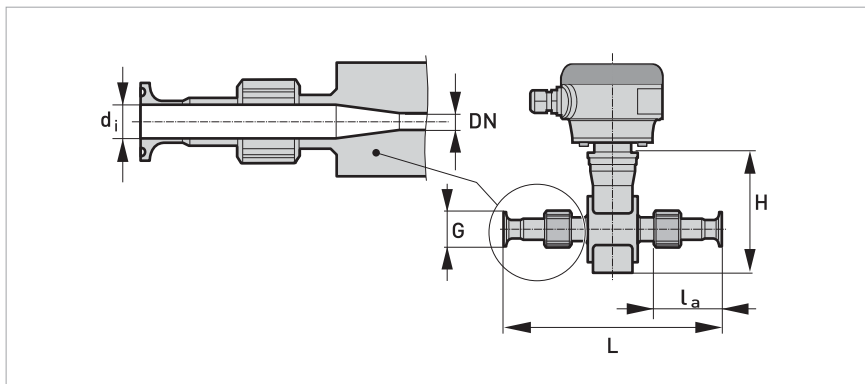

DN2.5...10 screwed adapter with DN10 process connections / DN17.2 screwed adapter

Nominal size			Dimensions [mm]						Approx. weight [kg]
			Adapter			Flowmeter			
DN	[Inch]	PN	$d_i$	G	$l_a$	L	H	W	
2.5...10	1/10"...3/8"	16	10	34	51.6	219	142	44	1.8
17.2	1/2"	16	16	34	51.6	219	142	44	1.8

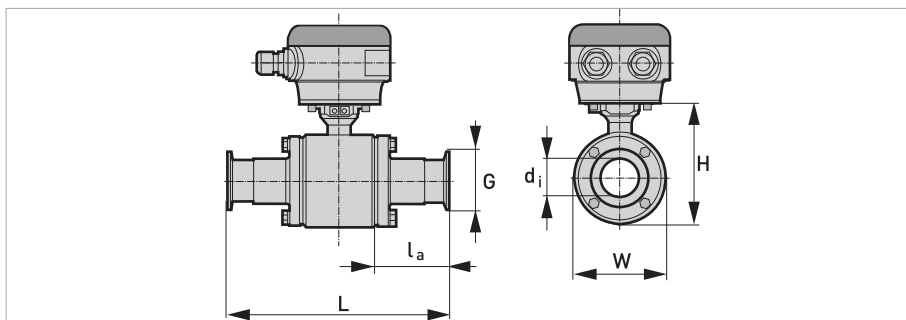

DN25...150 bolted adapter

Nominal size			Dimensions [mm]						Approx. weight
			Adapter			Flowmeter			
DN	[Inch]	PN	$d_i$	G	$l_a$	L	H	W	[kg]
25	1"	16	22.6	50,5	41.8	175	128	89	3.3
38	1.5"	16	35.6	50,5	87.8	273	153	114	5.4
50	2"	16	48.6	64	87.8	273	153	114	5.2
63.5	2.5"	10	60.3	77.5	68.3	273	180	141	9.5
76.1	3"	10	72.9	91	93.3	333	191	152	11.2
101.6	4"	8	97.6	119	85.8	333	242	203	19.1
114.3	5"	5	110.3	211	90	366	259	219	30
139.7	6"	5	135.7	246	90	376	294	254	45

## Tri Clamp

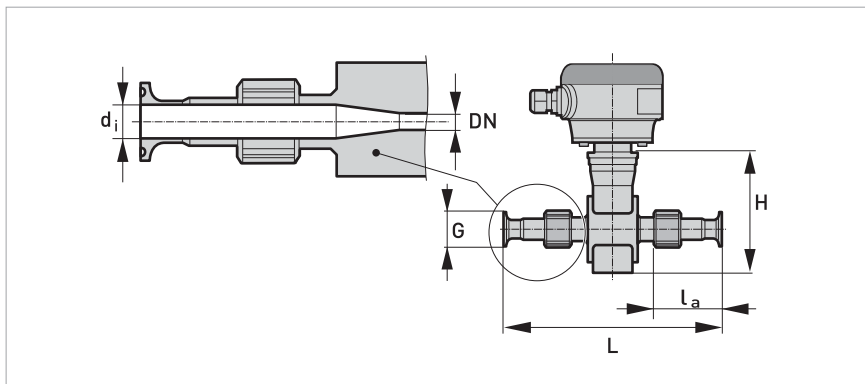

DN1/10...1/2" screwed adapter

Nominal size		Dimensions [inch]						Approx. weight
		Adapter			Flowmeter			
DN	PN	$d_i$	G	$l_a$	L	H	W	[kg]
1/10"...3/8"	20	0.37	0.98	1.97	8.5	5.59	1.73	1.5
1/2"	20	0.62	0.98	1.97	8.5	5.59	1.73	1.5

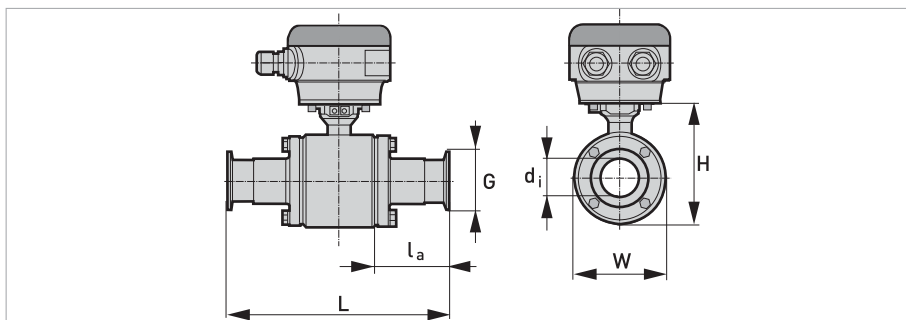

DN1...6" bolted adapter

Nominal size		Dimensions [inch]						Approx. weight
		Adapter			Flowmeter			
DN	PN	$d_i$	G	$l_a$	L	H	W	[kg]
1"	20	0.85	1.98	1.02	5.64	5.04	3.5	3.2
1½"	20	1.35	1.98	3.46	10.75	6.02	4.49	5.5
2"	20	1.85	2.52	3.46	10.75	6.02	4.49	5.3
2½"	20	2.35	3.05	2.69	10.75	7.09	5.55	10
3"	20	2.85	3.54	3.68	13.11	7.52	5.98	12.5
4"	12	3.83	4.68	3.38	13.11	9.53	7.99	21.8
5"	'-	4.78	5.69	3.54	14.43	10.20	8.62	30
6"	'-	5.78	6.57	3.62	14.80	11.57	10.00	45

## SMS 1146 Adapter

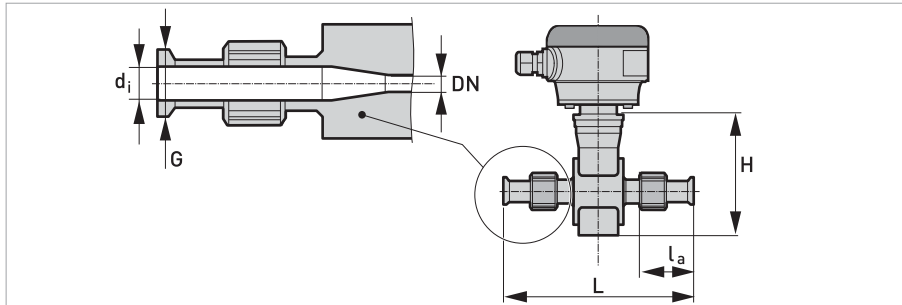

DN2.5...10 screwed adapter with DN10 process connections / DN15 screwed adapter

Nominal size		Dimensions [mm]						Approx. weight [kg]
		Adapter			Flowmeter			
DN	PN	d <sub>i</sub>	G	l <sub>a</sub>	L	H	W	
2.5	39	10	Rd 40-6	53	226	128	44	2
4	39	10	Rd 40-6	53	226	128	44	2
6	39	10	Rd 40-6	53	226	128	44	2
10	6	10	Rd 40-6	53	226	128	44	2
15	6	10	Rd 40-6	53	226	128	44	2

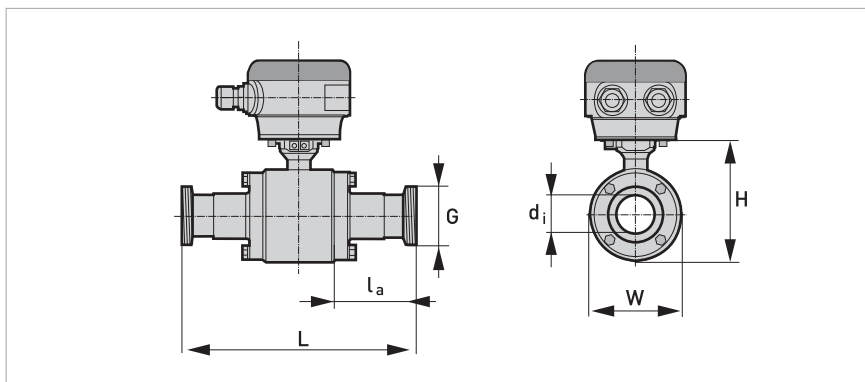

DN25...100 bolted adapter

Nominal size		Dimensions [mm]						Approx. weight
		Adapter			Flowmeter			
DN	PN	$d_i$	G	$l_a$	L	H	W	[kg]
25	6	22.6	Rd 40-6	28.1	147.6	128	89	3.2
38	6	35.5	Rd 60-6	54	262	153	114	5.7
51	6	48.6	Rd 70-6	84.3	266	153	114	5.4
63.5	6	60.3	Rd 85-6	69.8	276	180	141	9.9
76	6	72.9	Rd 98-6	99.8	346	191	152	12.1
100	6	97.6	Rd 132-6	44	336	242	203	21.9





## KROHNE – Process instrumentation and measurement solutions

- Flow
- Level
- Temperature
- Pressure
- Process Analysis
- Services

Head Office KROHNE Messtechnik GmbH  
Ludwig-Krohne-Str. 5  
47058 Duisburg (Germany)  
Tel.: +49 203 301 0  
Fax: +49 203 301 10389  
info@krohne.com

The current list of all KROHNE contacts and addresses can be found at:  
[www.krohne.com](http://www.krohne.com)

**KROHNE**