

OPTIFLUX 5000 Quick Start

Electromagnetic flowmeter in sandwich version

The documentation is only complete when used in combination with the relevant documentation for the signal converter.

1	Safety instructions	3
<hr/>		
2	Installation	4
<hr/>		
2.1	Scope of delivery.....	4
2.2	Device description	5
2.3	Nameplates (examples)	6
2.4	Storage	7
2.5	Transport	7
2.6	Pre-installation requirements	7
2.7	General requirements	8
2.7.1	Vibration	8
2.7.2	Magnetic field.....	8
2.8	Installation conditions	9
2.8.1	Inlet and outlet	9
2.8.2	Bends in 2 or 3 dimensions.....	9
2.8.3	T-section	10
2.8.4	Bends	10
2.8.5	Open feed or discharge	11
2.8.6	Flange deviation	11
2.8.7	Pump	11
2.8.8	Control valve	12
2.8.9	Air venting and vacuum forces	12
2.8.10	Mounting position.....	13
2.9	Mounting	13
2.9.1	Torques and pressure.....	13
3	Electrical connections	16
<hr/>		
3.1	Safety instructions.....	16
3.2	Grounding	16
3.3	Virtual reference for IFC 300 (W and F version).....	17
3.4	Connection diagrams	17
4	Technical data	18
<hr/>		
4.1	Dimensions and weights	18
5	Notes	22
<hr/>		

Warnings and symbols used



DANGER!

This information refers to the immediate danger when working with electricity.



DANGER!

These warnings must be observed without fail. Even partial disregard of this warning can lead to serious health problems and even death. There is also the risk of seriously damaging the device or parts of the operator's plant.



WARNING!

Disregarding this safety warning, even if only in part, poses the risk of serious health problems. There is also the risk of damaging the device or parts of the operator's plant.



CAUTION!

Disregarding these instructions can result in damage to the device or to parts of the operator's plant.



INFORMATION!

These instructions contain important information for the handling of the device.



HANDLING

- This symbol designates all instructions for actions to be carried out by the operator in the specified sequence.

➔ **RESULT**

This symbol refers to all important consequences of the previous actions.

Safety instructions for the operator



CAUTION!

Installation, assembly, start-up and maintenance may only be performed by appropriately trained personnel. The regional occupational health and safety directives must always be observed.



LEGAL NOTICE!

The responsibility as to the suitability and intended use of this device rests solely with the user. The supplier assumes no responsibility in the event of improper use by the customer. Improper installation and operation may lead to loss of warranty. In addition, the "Terms and Conditions of Sale" apply which form the basis of the purchase contract.



INFORMATION!

- Further information can be found on the supplied CD-ROM in the manual, on the data sheet, in special manuals, certificates and on the manufacturer's website.
- If you need to return the device to the manufacturer or supplier, please fill out the form contained on the CD-ROM and send it with the device. Unfortunately, the manufacturer cannot repair or inspect the device without the completed form.

2.1 Scope of delivery



INFORMATION!

Do a check of the packing list to make sure that you have all the elements given in the order.



INFORMATION!

Inspect the packaging carefully for damages or signs of rough handling. Report damage to the carrier and to the local office of the manufacturer.



INFORMATION!

The remote version will arrive in two cartons. One carton contains the converter and one carton contains the sensor.

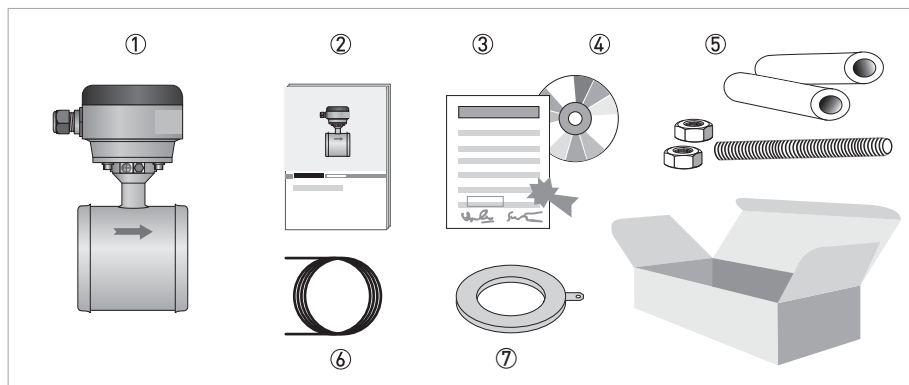

Figure 2-1: Scope of delivery

- ① Ordered flowmeter
- ② Product documentation
- ③ Factory calibration report
- ④ CD-ROM with product documentation in available languages
- ⑤ Mounting material (rubber sleeves). Optional; studs and bolts.
- ⑥ Signal cable (remote versions only)
- ⑦ Grounding rings (optional)



INFORMATION!

Assembly materials and tools are not part of the delivery. Use the assembly materials and tools in compliance with the applicable occupational health and safety directives.

2.2 Device description

Electromagnetic flowmeters are designed exclusively to measure the flow and conductivity of electrically conductive, liquid media.

Your measuring device is supplied ready for operation. The factory settings for the operating data have been made in accordance with your order specifications.



INFORMATION!

Product specific information and extensive product specification is available using PICK, the Product Information Center KROHNE web-tool.

PICK can be found via the service menu button on the KROHNE.com website.



The following versions are available:

- Compact version (the signal converter is mounted directly on the measuring sensor)
- Remote version (a measuring sensor with connection box and a separate signal converter)

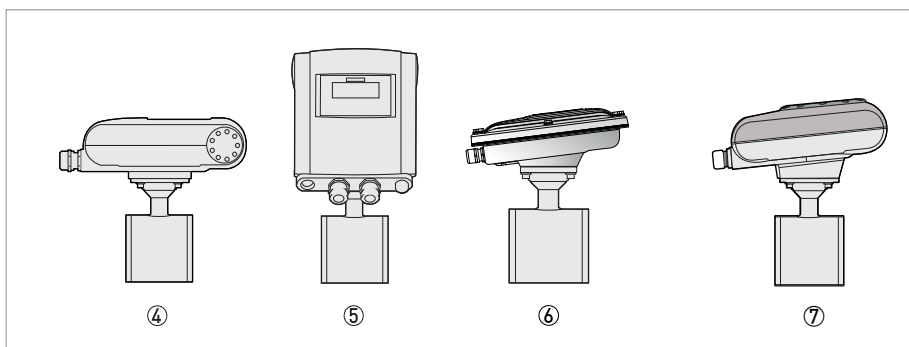
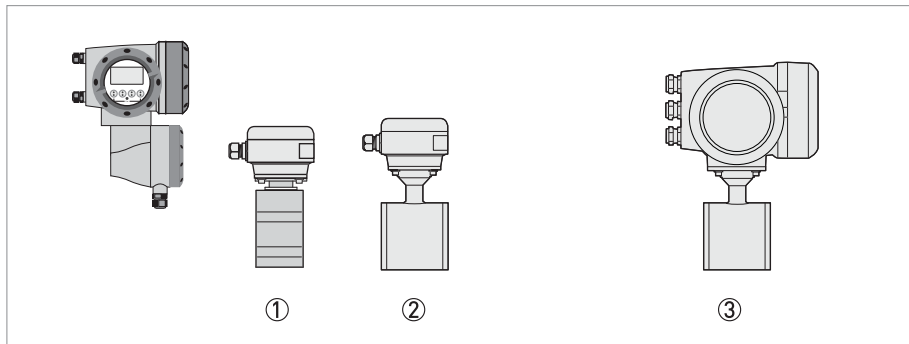

- ① Remote version (DN2.5...15)
- ② Remote version (DN25...100)
- ③ Compact version with IFC 300 signal converter
- ④ Compact version with IFC 100 (0°) signal converter
- ⑤ Compact version with IFC 100 (45°) signal converter
- ⑥ Compact version with IFC 100 SS (10°) signal converter
- ⑦ Compact version with IFC 050 (10°) signal converter

2.3 Nameplates (examples)



INFORMATION!

Look at the device nameplate to ensure that the device is delivered according to your order.
Check for the correct supply voltage printed on the nameplate.

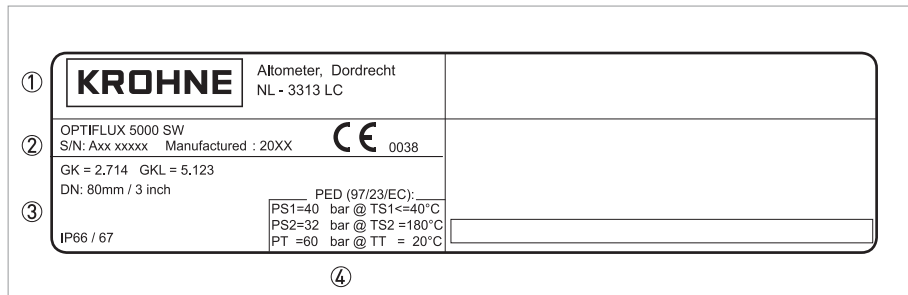

- ① Name and address of the manufacturer
- ② Type designation of the flowmeter, and CE sign with number(s) of notified body / bodies
- ③ Calibration data
- ④ PED data

2.4 Storage

- Store the device in a dry and dust-free location.
- Avoid lasting direct exposure to the sun.
- Store the device in its original packaging.
- Storage temperature: -50...+70°C / -58...+158°F

2.5 Transport

Signal converter

- No special requirements.

Compact version

- Do not lift the device by the signal converter housing.
- Do not use lifting chains.
- To transport the device, use lifting straps.

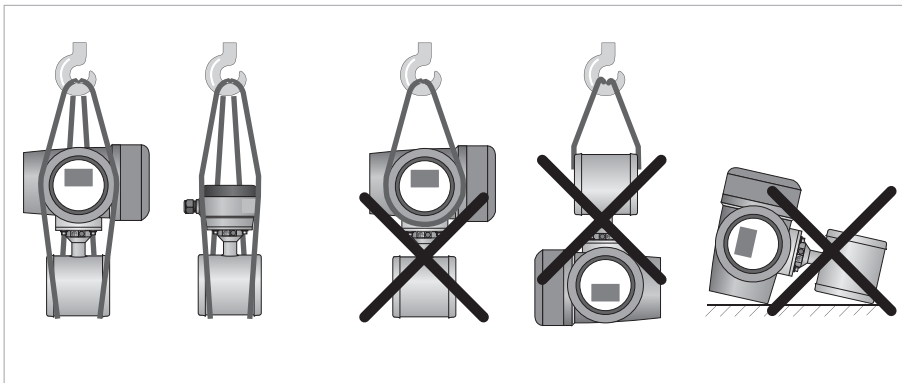

Figure 2-2: Transport

2.6 Pre-installation requirements

Make sure that you have all necessary tools available:

- Allen key (4 mm)
- Small screwdriver
- Wrench for cable glands
- Wrench for wall mounting bracket (remote version only)
- Torque wrench for installing flowmeter in pipeline

2.7 General requirements



INFORMATION!

The following precautions must be taken to ensure reliable installation.

- Make sure that there is adequate space to the sides.
- Protect the signal converter from direct sunlight and install a sun shade if necessary.
- Signal converters installed in control cabinets require adequate cooling, e.g. by fan or heat exchanger.
- Do not expose the signal converter to intense vibration. The flowmeters are tested for a vibration level in accordance with IEC 68-2-64.

2.7.1 Vibration

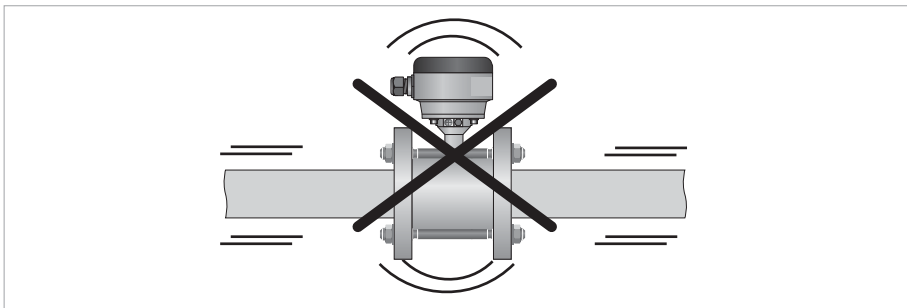

Figure 2-3: Avoid vibrations

2.7.2 Magnetic field

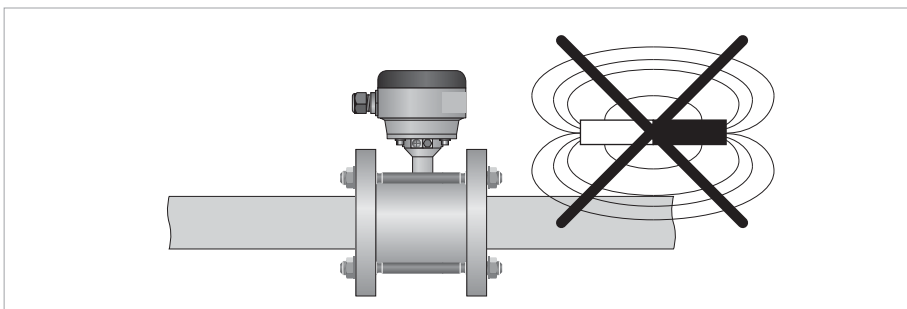

Figure 2-4: Avoid magnetic fields

2.8 Installation conditions

2.8.1 Inlet and outlet

Use straight inlet and outlet pipe sections to prevent flow distortion or swirl, caused by bends and T-sections.

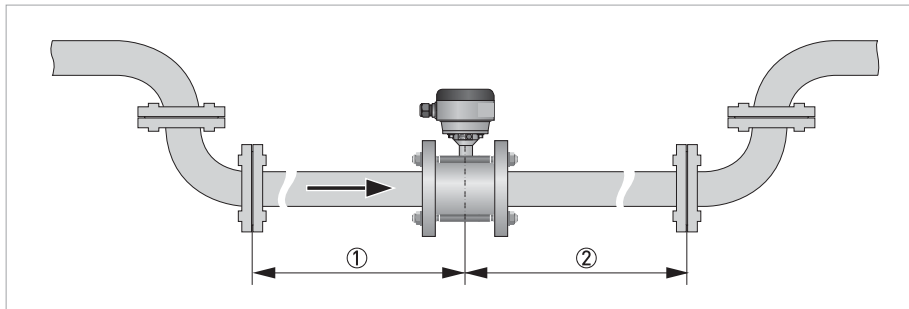

Figure 2-5: Recommended inlet and outlet section

- ① Refer to chapter "Bends in 2 or 3 dimensions"
- ② ≥ 2 DN

2.8.2 Bends in 2 or 3 dimensions

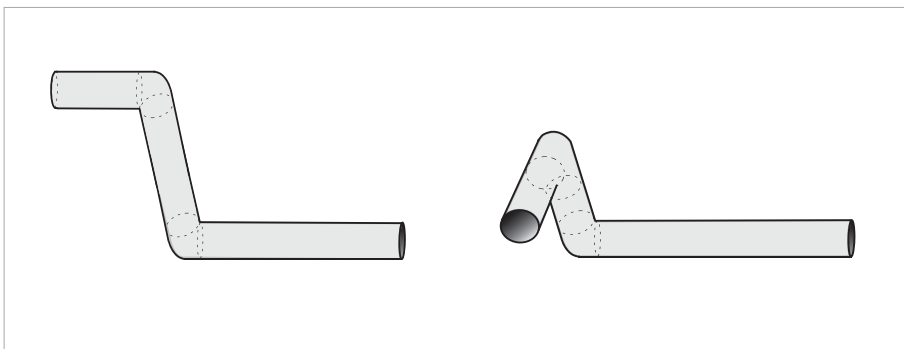

Figure 2-6: Inlet when using 2 and/or 3 dimensional bends upstream of the flowmeter

Inlet length: using bends in 2 dimensions: ≥ 5 DN; when having bends in 3 dimensions: ≥ 10 DN



INFORMATION!

*2 Dimensional bends occur in a vertical plane only, while 3 Dimensional bends occur in both vertical **and** horizontal plane.*

2.8.3 T-section

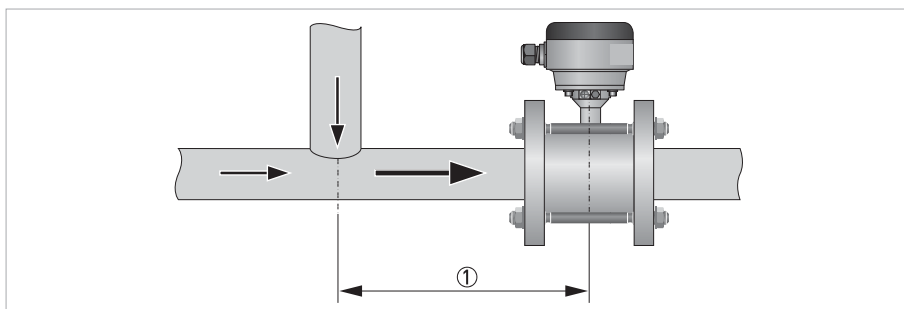
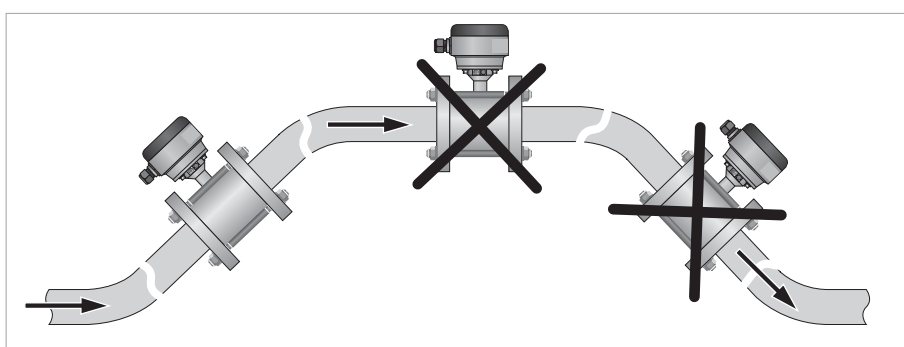
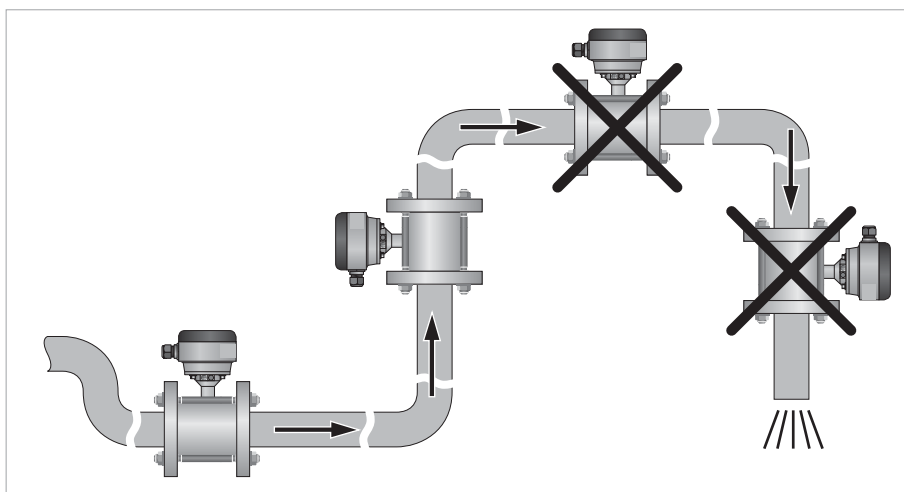

Figure 2-7: Distance behind a T-section

① ≥ 10 DN

2.8.4 Bends



CAUTION!
Avoid draining or partial filling of the flow sensor

2.8.5 Open feed or discharge

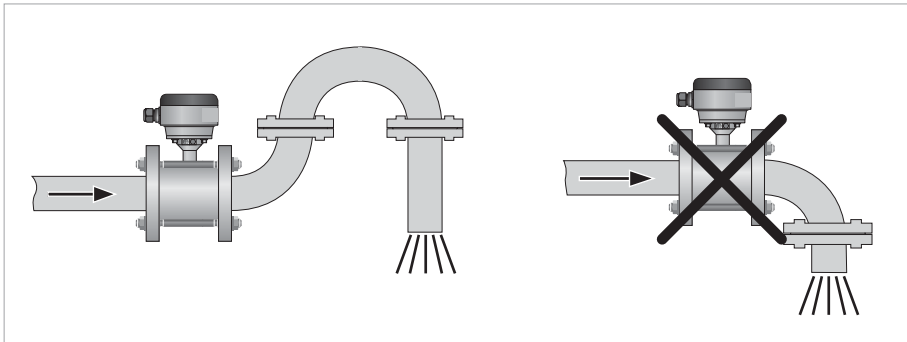

Figure 2-8: Installation in front of an open discharge

2.8.6 Flange deviation



CAUTION!

Max. permissible deviation of pipe flange faces:
 $L_{max} - L_{min} \leq 0.5 \text{ mm} / 0.02''$

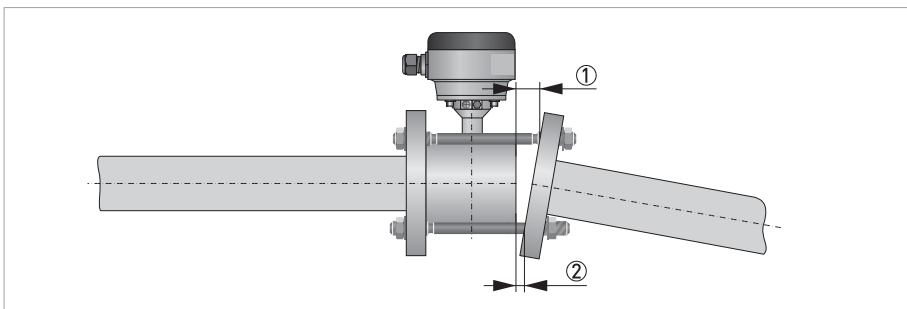

Figure 2-9: Flange deviation

- ① L_{max}
- ② L_{min}

2.8.7 Pump

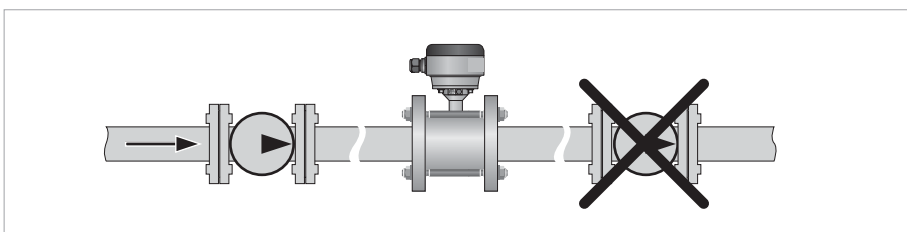

Figure 2-10: Installation behind a pump

2.8.8 Control valve

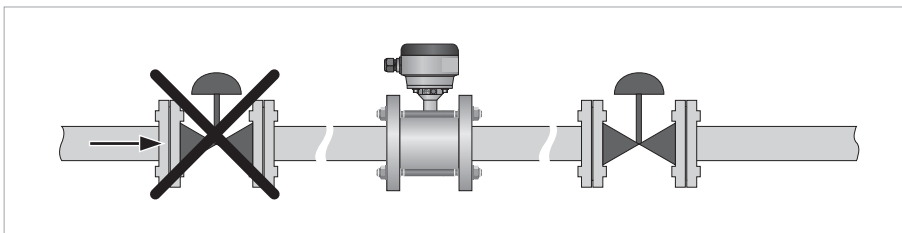

Figure 2-11: Installation in front of a control valve

2.8.9 Air venting and vacuum forces

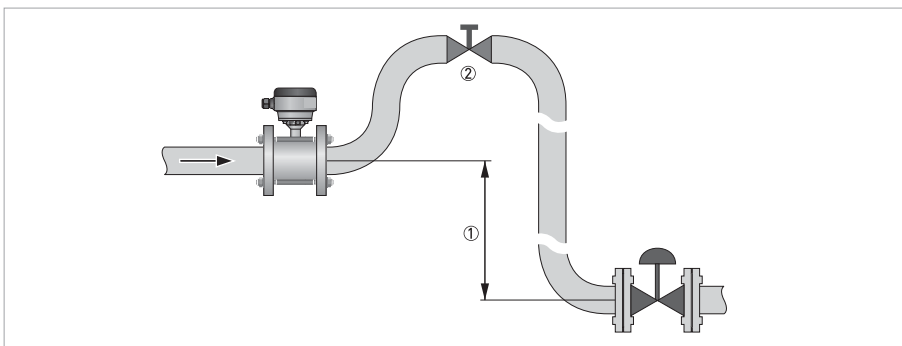

Figure 2-12: Air venting

- ① ≥ 5 m / 17 ft
- ② Air ventilation point

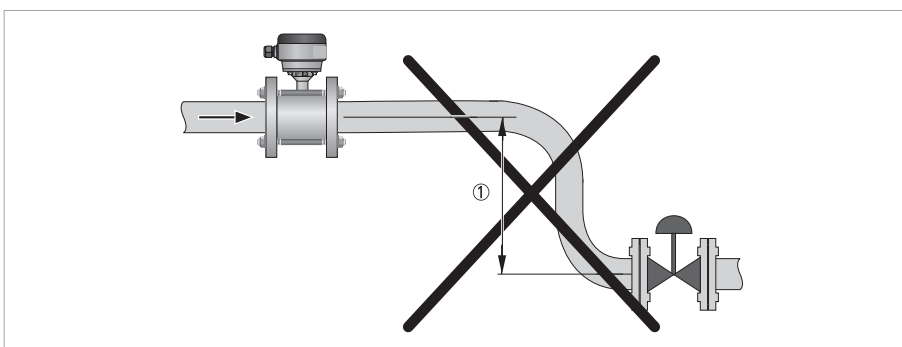

Figure 2-13: Vacuum

- ① ≥ 5 m / 17 ft

2.8.10 Mounting position

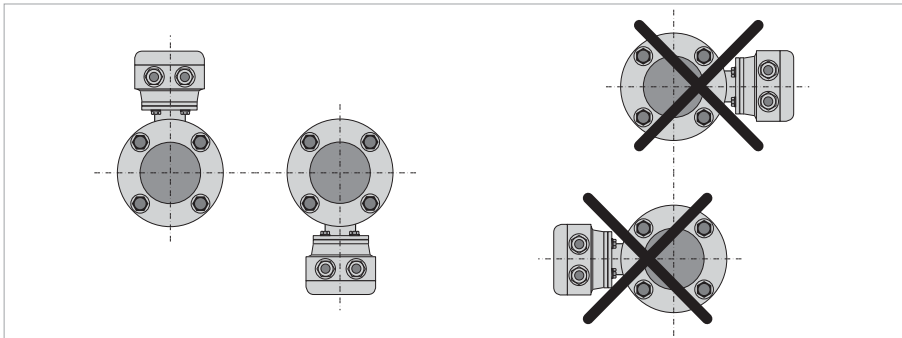

Figure 2-14: Mounting position

2.9 Mounting



CAUTION!

Please take care to use the proper gasket to prevent damaging the liner of the flowmeter. In general, the use of spiral wound gaskets is not advised, as it could severely damage the liner of the flowmeter.

2.9.1 Torques and pressure



WARNING!

- Please use stainless steel A2 / 6.9 class bolts.
- Make sure the connecting flanges are of type raised face (RF).

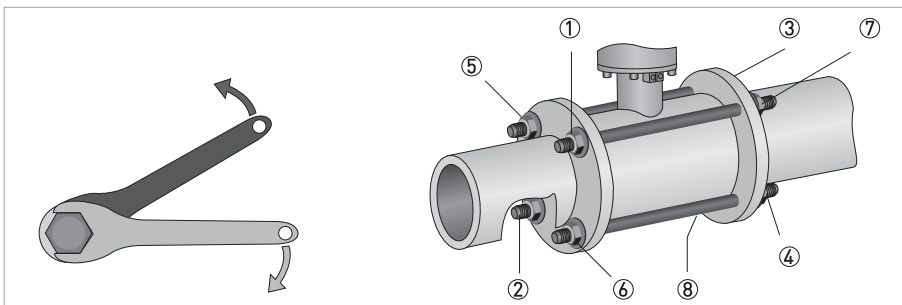

Figure 2-15: Tighten the bolts in fixed order, see picture.

Max. torque:

- Step 1: approx. 50% of max. torque
- Step 2: approx. 80% of max. torque
- Step 3: 100% of max. torque given in tables

EN 1092-1

Nominal size DN [mm]	Pressure rating	Max. allowable operating pressure [bar]
2.5...80	PN 40	40
100	PN 16	16
100	PN 25	25

ASME B 16.5

Nominal size [inch]	Pressure rating	Max. allowable operating pressure [psig]
1/10...4"	150 lb	230
1/10...3"	300 lb	580

**CAUTION!**

- Pressures at 20°C / 68°F.
- For higher temperatures, the pressure and temperature ratings are as per ASME B16.5.

**INFORMATION!**

The specified torque values are dependent on variables (temperature, bolt material, gasket material, lubricants, etc.) which are not within the control of the manufacturer. Therefore the values should be regarded as indicative only.

EN 1092-1

Nominal size DN [mm]	Counter flanges & bolts		Max. allowable torque					
			Gasket: Filled PTFE / PTFE / PF29		Gasket: Graphite		O-ring	
	Rating	Size	Nm	ft-lb	Nm	ft-lb	Nm	ft-lb
2.5...10	PN 40	M12 x 141	-	-	-	-	32	24
15	PN 40	M12 x 141	-	-	-	-	36	27
25	PN 40	M12 x 141	22	16	32	24	-	-
40	PN 40	M16 x 176	47	35	66	49	-	-
50	PN 40	M16 x 203	58	43	82	60	-	-
80	PN 40	M16 x 261	48	35	69	51	-	-
100	PN 16	M16 x 303	75	55	106	78	-	-
100	PN 25	M20 x 176	94	69	133	98	-	-

ASME B 16.5

Nominal size [inch]	Counter flanges & bolts		Max. allowable torque					
			Gaskets: Filled PTFE / PTFE / PF29		Gaskets: Graphite		O-ring	
	Rating	Size	Nm	ft-lb	Nm	ft-lb	Nm	ft-lb
1/10...3/8 "	150 lb	1/2"UNC x 142	-	-	-	-	35	26
1/2"	150 lb	1/2"UNC x 142	-	-	-	-	35	26
1"	150 lb	1/2"UNC x 142	24	18	33	24	-	-
1 1/2"	150 lb	1/2"UNC x 174	38	28	54	40	-	-
2"	150 lb	5/8"UNC x 215	58	43	83	61	-	-
3"	150 lb	5/8"UNC x 268	98	72	138	102	-	-
4"	150 lb	5/8"UNC x 318	75	55	108	80	-	-

3.1 Safety instructions



DANGER!

All work on the electrical connections may only be carried out with the power disconnected. Take note of the voltage data on the nameplate!



DANGER!

Observe the national regulations for electrical installations!



DANGER!

For devices used in hazardous areas, additional safety notes apply; please refer to the Ex documentation.



WARNING!

Observe without fail the local occupational health and safety regulations. Any work done on the electrical components of the measuring device may only be carried out by properly trained specialists.



INFORMATION!

Look at the device nameplate to ensure that the device is delivered according to your order. Check for the correct supply voltage printed on the nameplate.

3.2 Grounding



DANGER!

The device must be grounded in accordance with regulations in order to protect personnel against electric shocks.

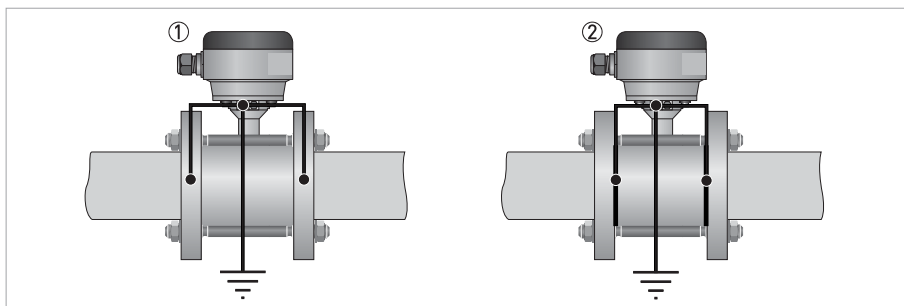

Figure 3-1: Grounding

- ① Metal pipelines, not internally coated. Grounding without grounding rings!
- ② Metal pipelines with internal coating and non-conductive pipelines. Grounding with grounding rings!



Figure 3-2: Grounding ring number 1

Grounding ring number 1 (optional for DN25...150 / 1...6"): Thickness: 3 mm / 0.1" (tantalum: 0.5 mm / 0.02")



INFORMATION!

For diameter DN10 / 3/8" and DN15 / 1/2", grounding rings are integrated as standard in the flow sensor construction.

3.3 Virtual reference for IFC 300 (W and F version)

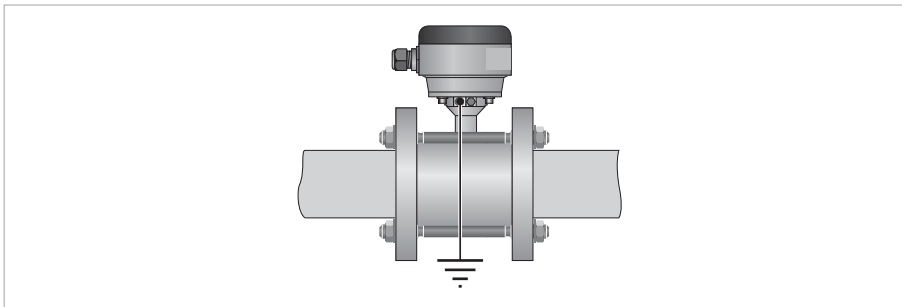

Figure 3-3: Virtual reference

Minimum requirements:

- Size: \geq DN10 / 3/8"
- Electrical conductivity: \geq 200 μ S/cm
- Signal cable: max. 50 m / 164 ft, type DS

3.4 Connection diagrams



INFORMATION!

For the connection diagrams, please refer to the documentation of the applicable converter.

4.1 Dimensions and weights

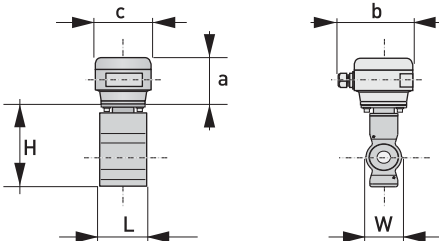
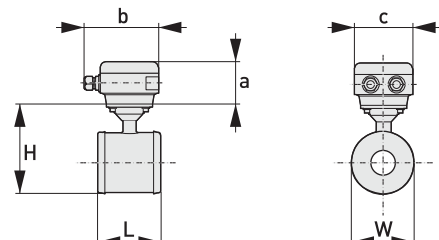
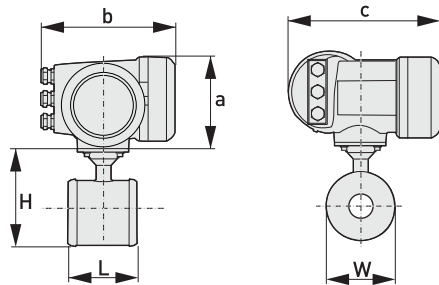
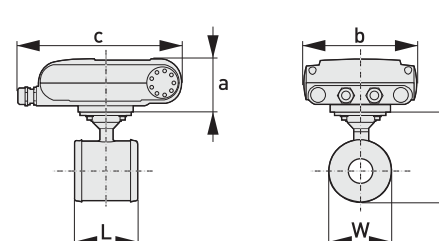
<p>Remote version: DN2.5...15 / 1/10...1/2"</p>		<p>a = 88 mm / 3.5" b = 139 mm / 5.5" ① c = 106 mm / 4.2" Total height = H + a</p>
<p>Remote version: DN25...100 / 1...4"</p>		<p>a = 88 mm / 3.5" b = 139 mm / 5.5" ① c = 106 mm / 4.2" Total height = H + a</p>
<p>Compact version with IFC 300</p>		<p>a = 155 mm / 6.1" b = 230 mm / 9.1" ① c = 260 mm / 10.2" Total height = H + a</p>
<p>Compact version with IFC 100 (0°)</p>		<p>a = 82 mm / 3.2" b = 161 mm / 6.3" c = 257 mm / 10.1" ① Total height = H + a</p>

Compact version with IFC 100 (45°)		$a = 186 \text{ mm} / 7.3''$ $b = 161 \text{ mm} / 6.3''$ $c = 184 \text{ mm} / 2.7''$ ① Total height = $H + a$
Compact version with IFC 100 SS (10°)		$a = 100 \text{ mm} / 4''$ $b = 187 \text{ mm} / 7.36''$ ① $c = 270 \text{ mm} / 10.63''$ Total height = $H + a$
Compact version with IFC 050 (10°)		$a = 100 \text{ mm} / 4''$ $b = 157 \text{ mm} / 6.18''$ ① $c = 260 \text{ mm} / 10.24''$ Total height = $H + a$

① The value may vary depending on the used cable glands.

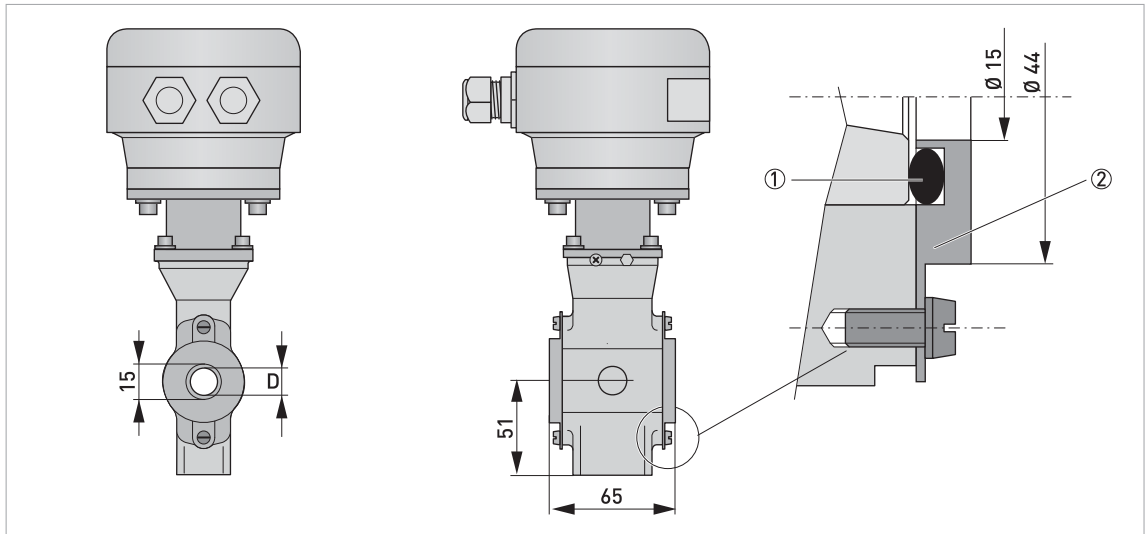

Figure 4-1: Construction details DN2.5...15 / 1/10...1/2"

- ① O-ring
- ② Grounding ring

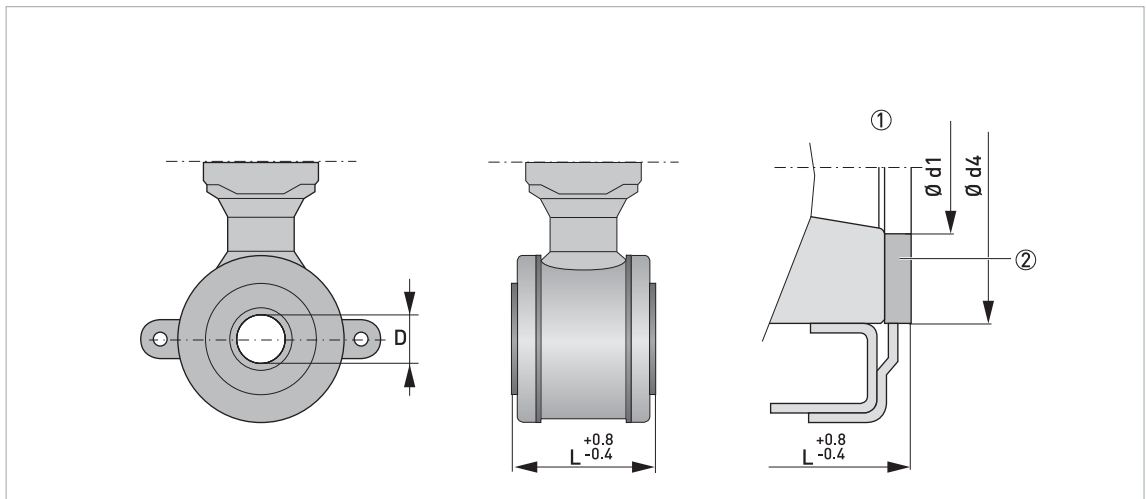

Figure 4-2: Construction details DN25...100 / 1...4"

- ① Situation without grounding rings
- ② Gasket



INFORMATION!

- All data given in the following tables are based on standard versions of the flow sensor only.
- Especially for smaller nominal sizes of the flow sensor, the signal converter can be bigger than the flow sensor.
- Note that for other pressure ratings than mentioned, the dimensions may be different.
- For full information on signal converter dimensions see relevant documentation.

Nominal size	Dimensions [mm]						Approx. weight [kg]	
	DN	L	H	W	D	Ød1		Ød4
2.5	65 ①	123	44			-	-	1.6
4	65 ①	123	44			-	-	1.6
6	65 ①	123	44			-	-	1.6
10	65 ①	123	44			-	-	1.6
15	65 ①	123	44			-	-	1.6
25	58 ②	116	68	20	26	46		1.6
40	83 ②	131	83	30	39	62		2.4
50	103 ②	149	101	40	51	74		2.9
80	153 ②	181	133	60	80	106		6.4
100	203 ②	206	158	80	101	133		8.8

① Total fitting length of flowmeter with integrated rings: dimension L + 2 x gasket thickness.

② Total fitting length of flowmeter without rings: dimension L only.

Nominal size	Dimensions [inches]						Approx. weight [lb]	
	ASME	L	H	W	D	Ød1		Ød4
1/10"	2.56 ①	4.84	1.73			-	-	3.53
1/8"	2.56 ①	4.84	1.73			-	-	3.53
¼"	2.56 ①	4.84	1.73			-	-	3.53
3/8"	2.56 ①	4.84	1.73			-	-	3.53
½"	2.56 ①	4.84	1.73			-	-	3.53
1"	2.28 ②	4.57	2.68	0.79	1.02	1.81		3.53
1½"	3.27 ②	5.16	3.27	1.18	1.54	2.44		5.29
2"	4.06 ②	5.87	3.98	1.57	2.01	2.91		6.39
3"	6.02 ②	7.13	5.24	2.36	3.15	4.17		14.11
4"	7.99 ②	8.11	6.22	3.15	3.98	5.24		19.40

① Total fitting length of flowmeter with integrated rings: dimension L + 2 x gasket thickness.

② Total fitting length of flowmeter without rings: dimension L only.







KROHNE – Process instrumentation and measurement solutions

- Flow
- Level
- Temperature
- Pressure
- Process Analysis
- Services

Head Office KROHNE Messtechnik GmbH
Ludwig-Krohne-Str. 5
47058 Duisburg (Germany)
Tel.: +49 203 301 0
Fax: +49 203 301 10389
info@krohne.com

The current list of all KROHNE contacts and addresses can be found at:
www.krohne.com

KROHNE