



IFC 070 Technical Datasheet

Electromagnetic signal converter

- Battery driven with low energy consumption
- Quick and easy to install and operate
- External data logger and GSM module for remote data transfer

1	Product features	3
<hr/>		
1.1	Solution for the water and wastewater industry	3
1.2	Features.....	5
1.3	Measuring principle.....	7
2	Technical data	8
<hr/>		
2.1	Technical data.....	8
2.2	Measuring accuracy	11
2.3	Dimensions and weights	12
3	Installation	13
<hr/>		
3.1	Notes on installation	13
3.2	Mounting position and flange deviation	13
3.3	Vibration.....	14
3.4	Magnetic field	14
4	Electrical connections	15
<hr/>		
4.1	Safety instructions.....	15
4.2	Installation of converter	15
4.3	Grounding	15
4.4	Connection of signal cable	16
4.5	Terminal assignment of converter.....	17
5	Notes	18
<hr/>		

1.1 Solution for the water and wastewater industry

The IFC 070 electromagnetic signal converter is designed for use in water industry such as potable water distribution networks, for revenue billing and for water abstraction. It is battery powered, making it especially suitable for applications where no power connection is available and provides certainty in case of power failure. Optional a GSM and data logger module is available for the remote transmission of measurement data and status information.

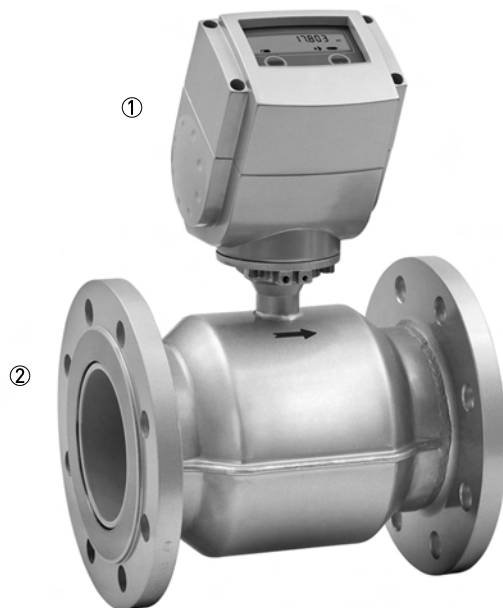

- ① Battery-powered totaliser
- ② Rigid flow sensor

Highlights

- Battery operated, stand alone water meter, battery life up to 15 years
- Excellent performance in low flow conditions and over a wide flow range
- Easy installation, short inlet and outlet runs, no filters and bi-directional flow
- Maintenance free operation, no moving parts, no wear and obstruction free
- Optional, battery powered data logger and GSM module for remote data transfer

Industries

- Water abstraction
- Distribution of potable water
- Irrigation

Applications

- Raw water, potable water, irrigation water
- Well chambers
- Monitoring of distribution networks
- Pipeline leakage detection
- Measuring water consumption

1.2 Features



GSM and data logger module

There is an increased demand by utilities for remote reading. Often water meters are installed at remote locations in the distribution network or below the ground for example in busy city centers. The IFC 070 can be supplied with a state-of-the-art data logger and GSM modem. The stored data is transmitted (for example once a day) by SMS and can be forwarded to the customer's management system.



Quick to install and easy to operate - Remote or Compact

The IFC 070 signal converter can be supplied in either compact or remote design. In case of a remote design, the converter can be installed on the wall or on a pipe. The functionality of the compact and remote versions is identical.

**Low energy consumption**

The IFC 070 signal converter has an extreme low power consumption. It delivers precise and reliable measurements for many years operating on batteries. With a sampling rate of 1/15 Hz, the water meter can operate for more than fifteen years.

**Long term reliability**

In addition to a long battery lifetime of up to 15 years, the IFC 070 provides diagnostic information. The IFC 070 has two status outputs for self checking, battery warnings and counter overrun.

1.3 Measuring principle

An electrically conductive fluid flows inside an electrically insulating pipe through a magnetic field. This magnetic field is generated by a current, flowing through a pair of field coils. Inside of the fluid, a voltage U is generated:

$$U = v * k * B * D$$

in which:

v = mean flow velocity

k = factor correcting for geometry

B = magnetic field strength

D = inner diameter of flow meter

The signal voltage U is picked off by electrodes and is proportional to the mean flow velocity v and thus the flow rate q . The signal voltage is quite small (typically 1 mV at $v = 3$ m/s / 10 ft/s and field coil power of 1 W). Finally, a signal converter is used to amplify the signal voltage, filter it (separate from noise) and convert it into signals for totalising, recording and output processing.

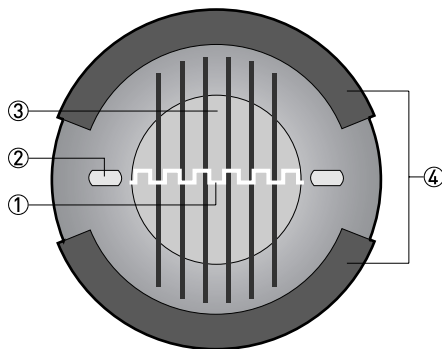

- ① Voltage (induced voltage proportional to flow velocity)
- ② Electrodes
- ③ Magnetic field
- ④ Field coils

2.1 Technical data

- *The following data is provided for general applications. If you require data that is more relevant to your specific application, please contact us or your local representative.*
- *Additional information (certificates, special tools, software,...) and complete product documentation can be downloaded free of charge from the website (Downloadcenter).*

Measuring system

Measuring principle	Faraday's law
Application range	Electrically conductive fluids
Measured value	
Primary measured value	Flow velocity
Secondary measured value	Volume flow

Design

Modular construction	The measurement system consists of a flow sensor and a signal converter. It is available as compact and as remote version. More information about the sensor can be found in the relevant documentation.
Compact version	With WATERFLUX 3000 sensor: WATERFLUX 3070 C
	With OPTIFLUX 2000 sensor: OPTIFLUX 2070 C
Remote version	With WATERFLUX 3000 sensor: WATERFLUX 3070 F
	With OPTIFLUX 2000 sensor: OPTIFLUX 2070 F
	Maximum cable length 25 m / 75 ft
User interface	
Display	8 digits LCD
	Display of positive and negative counter, sum counter, flow rate
	Status indication for battery, flow / counter direction, empty pipe
Units	Volume in m ³ , US Gallons
	Flow rate in m ³ /h, USGPM
Cable connections	Standard: 2x M20x1.5
	Optional: ½" NPT, PF½

Measuring accuracy

Reference conditions	Medium: water
	Temperature: 20°C / 68°F
	Inlet section: 5 DN
	Operating pressure: 1 bar / 14.5 psig
Maximum measuring error	±0.2% of measured value ±1.5 mm/s / 0.06 inch/s
	For detailed information on the measuring accuracy, see chapter "Measuring accuracy".
Repeatability	±0.1% (v > 0.5 m/s / 1.5 ft/s)

Operating conditions

Temperature	
Process temperature	-5...+70°C / 23...+158°F
Ambient temperature	-40...+65°C / -40...+149°F
Storage temperature	-50...+70°C / -58...+158°F
Chemical properties	
Physical condition	Liquids
Electrical conductivity	≥ 20 μS/cm
Recommended flow velocity	in pipeline: -9...9 m/s / -30...30 ft/s
	in sensor: -18...18 m/s / -59...59 ft/s
Process conditions	Raw water, ground- and surface water
	Potable water
	Irrigation water

Installation conditions

Dimensions and weights	For detailed information see chapter "Dimensions and weights".
------------------------	--

Materials

Housing	Die-cast aluminium, polyurethane coated
Connection box (remote versions only)	Die-cast aluminium, polyurethane coated

Electrical connections

Power supply	
Battery	Standard
	1 Lithium battery (D-cell)
	Optional
	2 Lithium batteries (D-cell) External battery pack with 4 lithium batteries (D-cell)
Typical lifetime	See graph at the end of this table.
Alarm	Pre-alarm 1 year before battery depletion and final alarm
Battery replacement	Possible without loss of totalizer data
In- and output	
Outputs	2 Passive pulse outputs for remote totalising: f ≤ 500 Hz; I ≤ 10 mA; U: 5...24 VDC (P ≤ 100 mW)
	2 Passive status outputs: I ≤ 10 mA; U: 5...24 VDC (P ≤ 100 mW)
Communication	External data logger / GSM module, SMS protocol to:
	SCADA system (at customer's site)
	OPC server (to be connected to customer's OPC client)
	PCWin (mini-SCADA can be supplied by KROHNE)

Approvals and certifications

CE Sign	This device fulfills the statutory requirements of the EC directives. The manufacturer certifies successful testing of the product by applying the CE mark.
Hazardous areas	
Non-Ex	Standard
ATEX	Not available
Other approvals and standards	
Protection category acc. to IEC 529 / EN 60529	IP 66/67 (NEMA 4/4X/6)
Shock- and vibration resistance	IEC 68-2-3
Electromagnetic compatibility	Directive: 89/336/EEC
	Harmonized standard: EN 61326-1 : 2006
Low voltage directive	Directive: 2006/95/EC
	Harmonized standard: EN 61010 : 2001
Custody transfer	Standard: without
	Europe: MI-001 pending
	Worldwide: OIML R-49 pending

Typical lifetime of batteries (at 25°C)

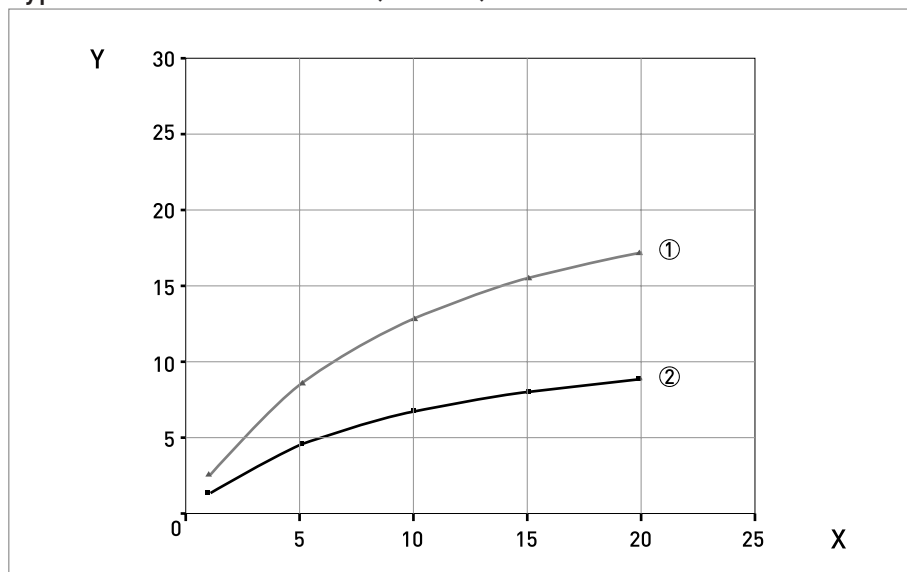

Figure 2-1: X = Sampling interval in seconds, Y = typical lifetime in years

- ① dual battery pack
- ② single battery

2.2 Measuring accuracy

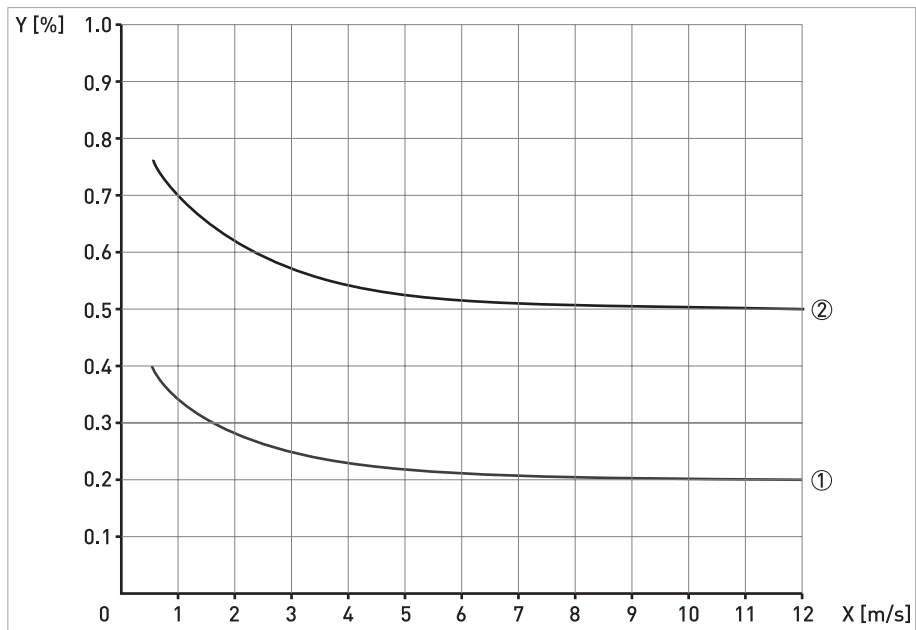
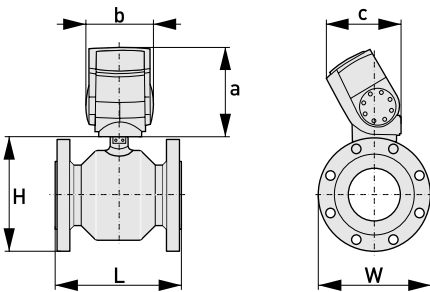
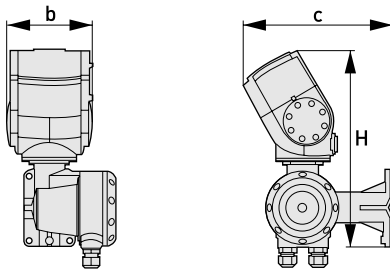

Figure 2-2: X [m/s]: flow velocity
Y [%]: deviation from the actual measured value

- ① with WATERFLUX 3000 water meter
- ② with OPTIFLUX 2000 flow sensor

2.3 Dimensions and weights

Compact version	
	<p>a = 170 mm / 6.7"</p>
	<p>b = 122 mm / 4.8"</p>
	<p>c = 140 mm / 5.5"</p>
	<p>Sizes of sensor can be found in the relevant datasheet.</p>
Remote version, signal converter	
	<p>b = 122 mm / 4.8"</p>
	<p>c = 335 mm / 13.2"</p>
	<p>H = 310 mm / 12.2"</p>

3.1 Notes on installation

Inspect the cartons carefully for damage or signs of rough handling. Report damage to the carrier and to the local office of the manufacturer.

Check the packing list to check if you received completely all that you ordered.

Look at the device nameplate to ensure that the device is delivered according to your order. Check for the correct supply voltage printed on the nameplate.

3.2 Mounting position and flange deviation

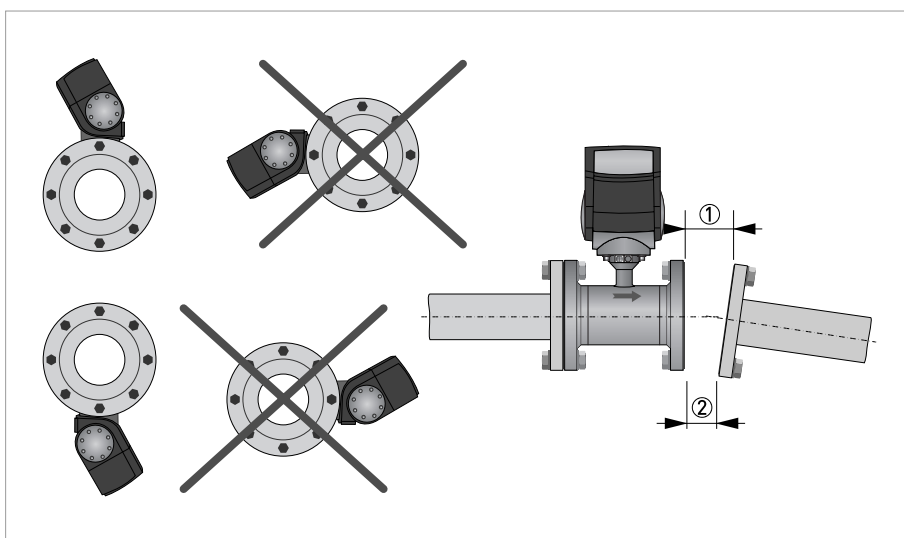

Figure 3-1: Mounting position and flange deviation

- ① L_{max}
- ② L_{min}

- Mount flowmeter either with converter aligned upwards or downwards.
- Install flowmeter in line with the pipe axis.
- Pipe flange faces must be parallel to each other.

Max. permissible deviation of pipe flange faces: $L_{max} - L_{min} \leq 0.5 \text{ mm}$

3.3 Vibration

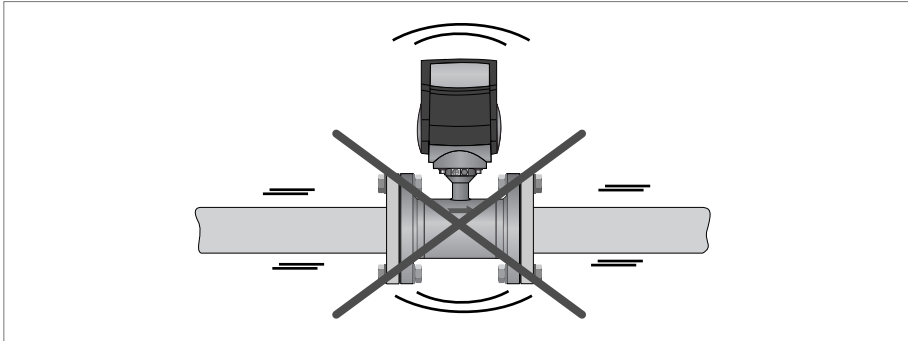

Figure 3-2: Avoid vibrations

3.4 Magnetic field

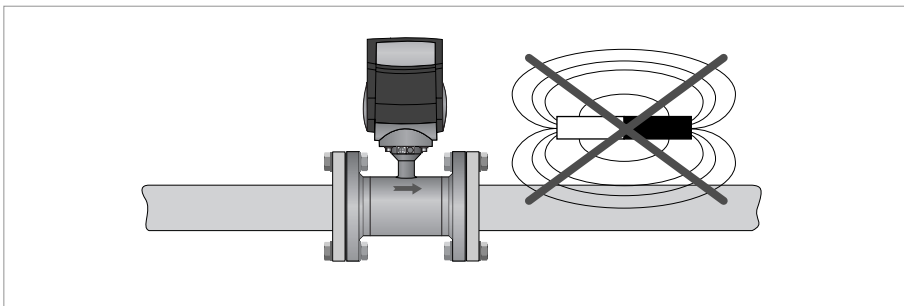

Figure 3-3: Avoid magnetic fields

4.1 Safety instructions

All work on the electrical connections may only be carried out with the power disconnected. Take note of the voltage data on the nameplate!

Observe the national regulations for electrical installations!

Observe without fail the local occupational health and safety regulations. Any work done on the electrical components of the measuring device may only be carried out by properly trained specialists.

Look at the device nameplate to ensure that the device is delivered according to your order. Check for the correct supply voltage printed on the nameplate.

4.2 Installation of converter

Only applicable for remote versions.

- Mount converter with mounting plate on wall or standpipe.
- Keep distance between sensor and signal converter as short as possible.
- Observe length of the delivered signal cable.

4.3 Grounding

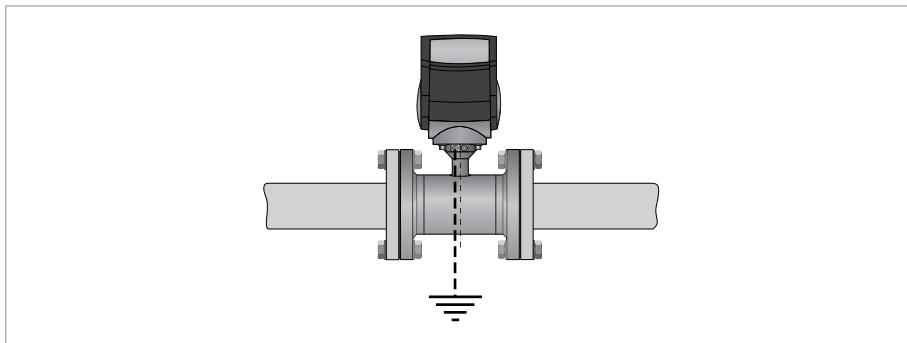

Figure 4-1: Grounding

4.4 Connection of signal cable

The signal cable is only used with remote versions. The standard cable includes both electrode and field current leads, the optional type A / B cable is only used for the electrodes. In that case, the field current cable is no part of the supply.

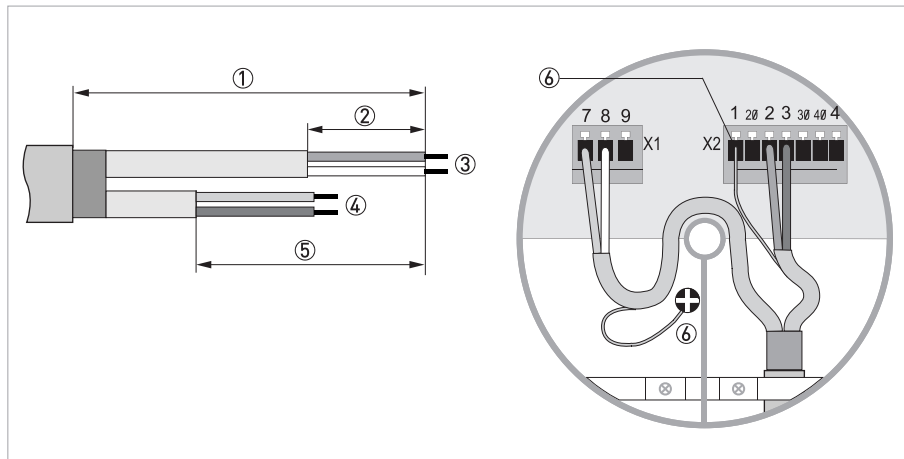

Figure 4-2: Cable connection at converter side, standard cable

- ① cable length: 13 cm / 5"
- ② cable length: 5 cm / 2"
- ③ brown + white cable, used for field current
- ④ purple and blue cable, used for electrode signals
- ⑤ cable length: 8 cm / 3"
- ⑥ Shield (terminal 1 of connector X2 + U-clamp)

- Prepare appropriate cable lengths (①...③)
- Connect the shield to the U-clamp, the brown cable to terminal 7 and the white to terminal 8.
- Connect the shield to terminal 1, the purple cable (red in case of type A or B cable) to terminal 2 and the blue (white in case of type A or B cable) to terminal 3.

4.5 Terminal assignment of converter

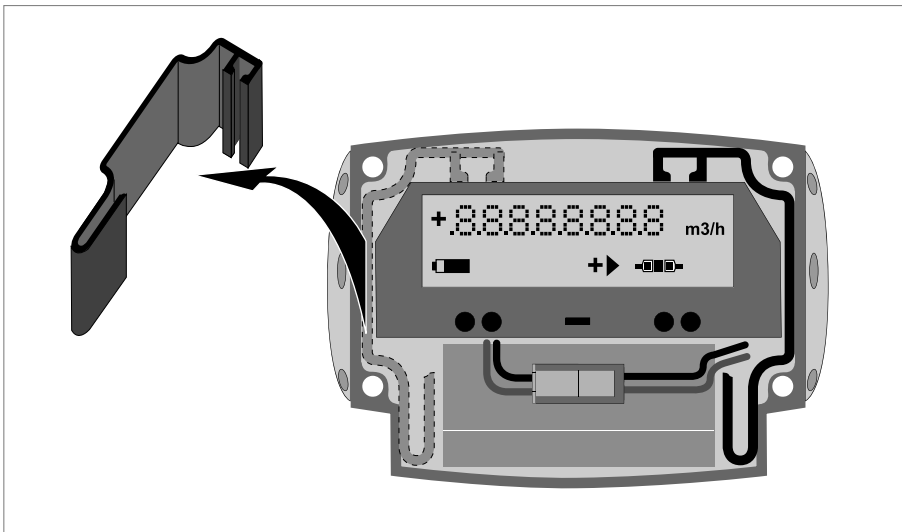

Figure 4-3: Removing side cap

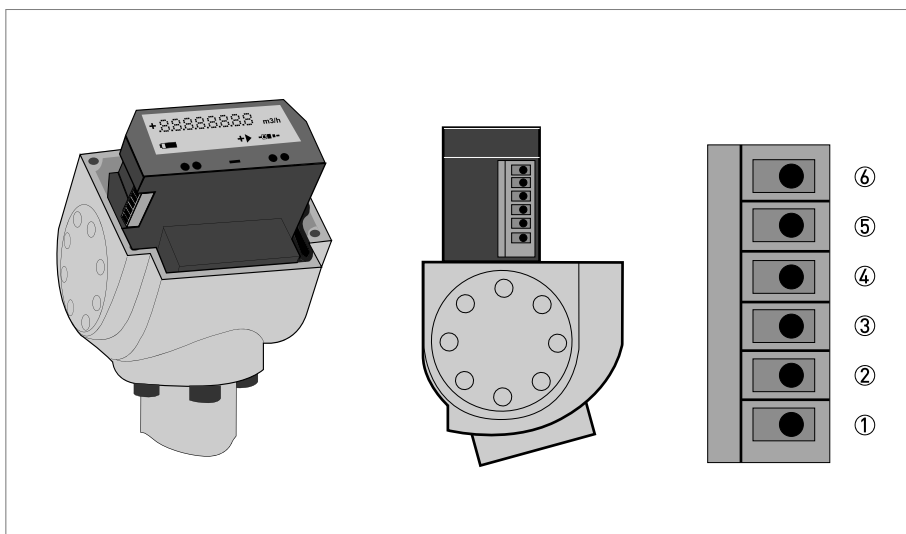

Figure 4-4: Terminal assignment

- ① Status output 1
- ② Status output 2
- ③ Not connected
- ④ Ground
- ⑤ Pulse output A
- ⑥ Pulse output B

Electrical values

- **Pulse output passive:**
 $f \leq 500 \text{ Hz}$; $I \leq 10 \text{ mA}$; $U: 5 \dots 24 \text{ VDC}$ ($P \leq 100 \text{ mW}$)
- **Status output passive:**
 $I \leq 10 \text{ mA}$; $U: 5 \dots 24 \text{ VDC}$ ($P \leq 100 \text{ mW}$)





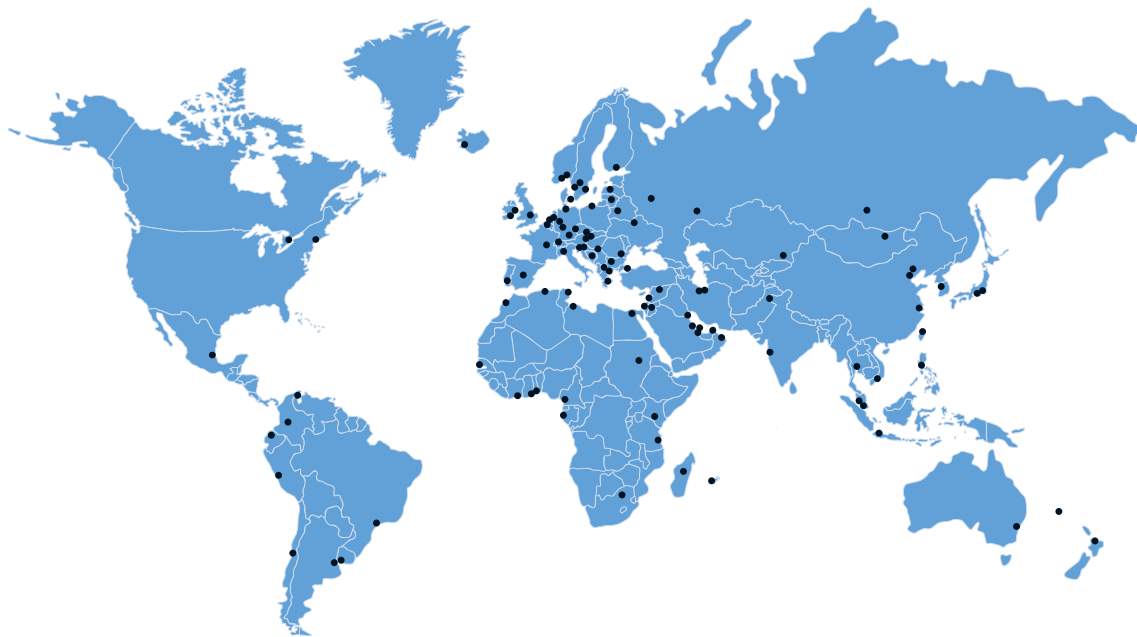

KROHNE product overview

- Electromagnetic flowmeters
- Variable area flowmeters
- Ultrasonic flowmeters
- Mass flowmeters
- Vortex flowmeters
- Flow controllers
- Level meters
- Temperature meters
- Pressure meters
- Analysis products
- Measuring systems for the oil and gas industry
- Measuring systems for sea-going tankers

Head Office KROHNE Messtechnik GmbH & Co. KG
Ludwig-Krohne-Str. 5
D-47058 Duisburg
Tel.: +49 (0)203 301 0
Fax: +49 (0)203 301 10389
info@krohne.de

The current list of all KROHNE contacts and addresses can be found at:
www.krohne.com

KROHNE