



IFC 050 Quick Start

Signal converter for electromagnetic flowmeters

Electronic revision:
ER 3.0.3_

The documentation is only complete when used in combination with the relevant documentation for the flow sensor.

1	Safety instructions	3
<hr/>		
2	Installation	4
<hr/>		
2.1	Intended use	4
2.2	Scope of delivery.....	4
2.3	Storage	5
2.4	Transport	5
2.5	Installation specifications	5
2.6	Mounting of the compact version.....	6
2.7	Mounting of the wall housing, remote version	6
3	Electrical connections	8
<hr/>		
3.1	Safety instructions.....	8
3.2	Important notes on electrical connection.....	8
3.3	Electrical cables for remote device versions, notes.....	9
3.3.1	Notes on signal cable A	9
3.3.2	Notes on field current cable C.....	9
3.3.3	Requirements for signal cables provided by the customer	10
3.4	Preparing the signal and field current cables	11
3.4.1	Signal cable A (type DS 300), construction.....	11
3.4.2	Preparing signal cable A, connection to signal converter	12
3.4.3	Length of signal cable A.....	13
3.4.4	Preparing field current cable C, connection to signal converter.....	14
3.4.5	Preparing signal cable A, connection to flow sensor.....	16
3.4.6	Preparing field current cable C, connection to flow sensor	17
3.5	Connecting the signal and field current cables.....	18
3.5.1	Connecting the signal and field current cables to the signal converter, remote version... ..	18
3.5.2	Connection diagram for signal and field current cable	19
3.6	Grounding the flow sensor	20
3.7	Connecting the power supply	20
3.8	Inputs and outputs, overview	22
3.8.1	Description of the CG number	22
3.8.2	Fixed, non-alterable output versions	22
3.9	Electrical connection of the outputs	23
3.9.1	Electrical connection of the outputs.....	23
3.9.2	Laying electrical cables correctly.....	24
4	Start-up	25
<hr/>		
4.1	Switching on the power	25
4.2	Starting the signal converter	25
5	Notes	26
<hr/>		

Warnings and symbols used



DANGER!

This information refers to the immediate danger when working with electricity.



DANGER!

These warnings must be observed without fail. Even partial disregard of this warning can lead to serious health problems and even death. There is also the risk of seriously damaging the device or parts of the operator's plant.



WARNING!

Disregarding this safety warning, even if only in part, poses the risk of serious health problems. There is also the risk of damaging the device or parts of the operator's plant.



CAUTION!

Disregarding these instructions can result in damage to the device or to parts of the operator's plant.



INFORMATION!

These instructions contain important information for the handling of the device.



HANDLING

- This symbol designates all instructions for actions to be carried out by the operator in the specified sequence.

➔ **RESULT**

This symbol refers to all important consequences of the previous actions.

Safety instructions for the operator



CAUTION!

Installation, assembly, start-up and maintenance may only be performed by appropriately trained personnel. The regional occupational health and safety directives must always be observed.



LEGAL NOTICE!

The responsibility as to the suitability and intended use of this device rests solely with the user. The supplier assumes no responsibility in the event of improper use by the customer. Improper installation and operation may lead to loss of warranty. In addition, the "Terms and Conditions of Sale" apply which form the basis of the purchase contract.



INFORMATION!

- Further information can be found on the supplied CD-ROM in the manual, on the data sheet, in special manuals, certificates and on the manufacturer's website.
- If you need to return the device to the manufacturer or supplier, please fill out the form contained on the CD-ROM and send it with the device. Unfortunately, the manufacturer cannot repair or inspect the device without the completed form.

2.1 Intended use

The electromagnetic flowmeters are designed exclusively to measure the flow and conductivity of electrically conductive, liquid media.



WARNING!

If the device is not used according to the operating conditions, the intended protection could be affected.



INFORMATION!

This device is a Group 1, Class A device as specified within CISPR11:2009. It is intended for use in industrial environment. There may be potential difficulties in ensuring electromagnetic compatibility in other environments, due to conducted as well as radiated disturbances.

2.2 Scope of delivery



INFORMATION!

Inspect the packaging carefully for damages or signs of rough handling. Report damage to the carrier and to the local office of the manufacturer.



INFORMATION!

Do a check of the packing list to make sure that you have all the elements given in the order.



INFORMATION!

Look at the device nameplate to ensure that the device is delivered according to your order. Check for the correct supply voltage printed on the nameplate.

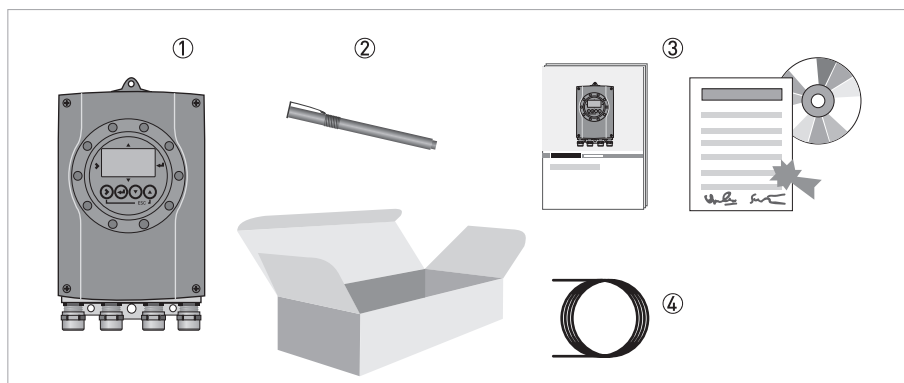

Figure 2-1: Scope of delivery

- ① Device in the version as ordered
- ② Bar pencil (to operate the signal converter when the housing is closed)
- ③ Documentation (calibration report, Quick Start, CD-Rom with product documentation for flow sensor and signal converter)
- ④ Signal cable (only for remote version)

2.3 Storage

- Store the device in a dry, dust-free location.
- Avoid continuous direct sunlight.
- Store the device in its original packing.
- Storage temperature: -40...+70°C / -40...+158°F

2.4 Transport

Signal converter

- No special requirements.

Compact version

- Do not lift the device by the signal converter housing.
- Do not use lifting chains.
- To transport flange devices, use lifting straps. Wrap these around both process connections.

2.5 Installation specifications



INFORMATION!

The following precautions must be taken to ensure reliable installation.

- *Make sure that there is adequate space to the sides.*
- *Protect the signal converter from direct sunlight and install a sun shade if necessary.*
- *Signal converters installed in control cabinets require adequate cooling, e.g. by fan or heat exchanger.*
- *Do not expose the signal converter to intense vibrations. The measuring devices are tested for a vibration level in accordance with IEC 68-2-64.*

2.6 Mounting of the compact version

**INFORMATION!**

The signal converter is mounted directly on the flow sensor. For installation of the flowmeter, please observe the instructions in the supplied product documentation for the flow sensor.

2.7 Mounting of the wall housing, remote version

**INFORMATION!**

Assembly materials and tools are not part of the delivery. Use the assembly materials and tools in compliance with the applicable occupational health and safety directives.

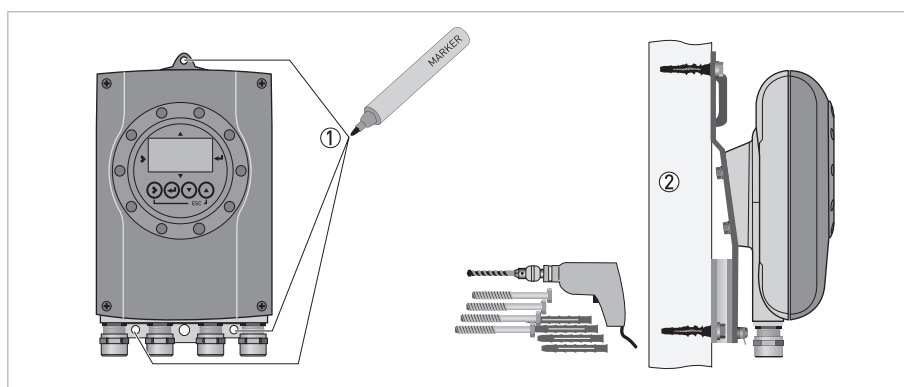

Figure 2-2: Mounting of the wall housing



- ① Prepare the holes with the aid of the mounting plate.
- ② Fasten the device securely to the wall with the mounting plate.

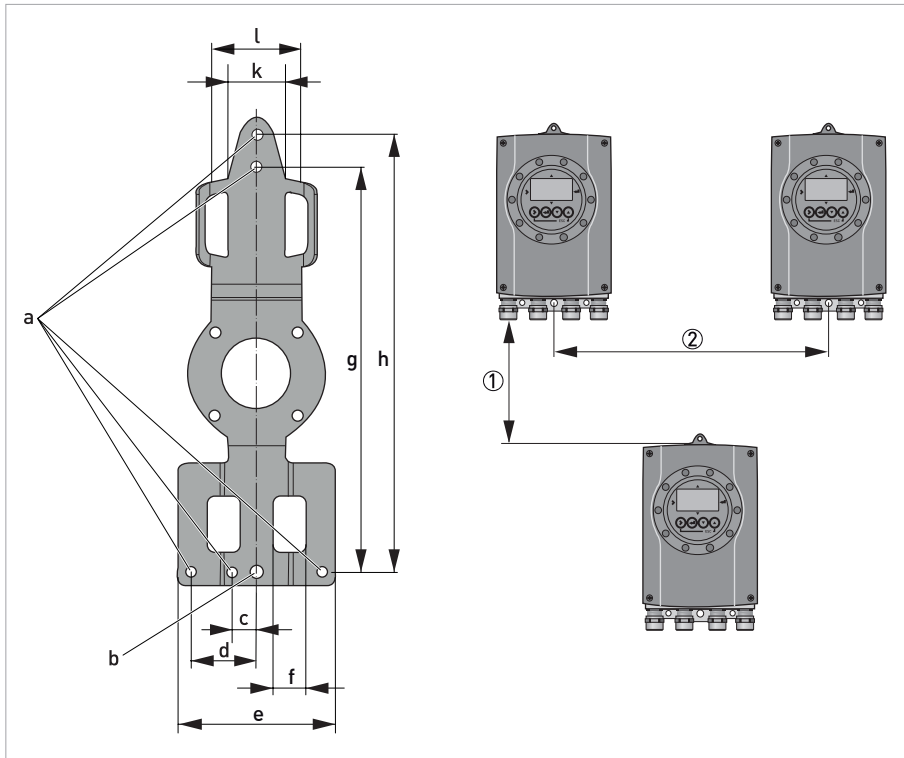

Figure 2-3: Dimensions of mounting plate and distances when mounting multiple devices next to each other

- ① 277 mm / 10.89"
- ② 310 mm / 12.2"

	[mm]	[inch]
a	Ø6.5	Ø0.26
b	Ø8.1	Ø0.3
c	15	0.6
d	40	1.6
e	96	3.8
f	20	0.8
g	248	9.8
h	268	10.5
k	35	1.4
l	55	2.2

3.1 Safety instructions

**DANGER!**

All work on the electrical connections may only be carried out with the power disconnected. Take note of the voltage data on the nameplate!

**DANGER!**

Observe the national regulations for electrical installations!

**WARNING!**

Observe without fail the local occupational health and safety regulations. Any work done on the electrical components of the measuring device may only be carried out by properly trained specialists.

**INFORMATION!**

Look at the device nameplate to ensure that the device is delivered according to your order. Check for the correct supply voltage printed on the nameplate.

3.2 Important notes on electrical connection

**DANGER!**

Electrical connection is carried out in conformity with the VDE 0100 directive "Regulations for electrical power installations with line voltages up to 1000 V" or equivalent national specifications.

**CAUTION!**

- Use suitable cable entries for the various electrical cables.
- The flow sensor and signal converter have been configured together at the factory. For this reason, please connect the devices in pairs. Ensure that the flow sensor constant GKL (refer to information on the nameplates) are identically set.
- If delivered separately or when installing devices that were not configured together, set the signal converter to the DN size and GKL of the flow sensor.

3.3 Electrical cables for remote device versions, notes

3.3.1 Notes on signal cable A



INFORMATION!

Signal cable A (type DS 300) with double shield ensures proper transmission of measured values.

Observe the following notes:

- Lay the signal cable with fastening elements.
- It is permissible to lay the signal cable in water or in the ground.
- The insulating material is flame-retardant to EN 50265-2-1: 1997 and IEC 60322-1-2: 2005.
- The signal cable does not contain any halogens and is unplasticized, and remains flexible at low temperatures.
- The connection of the inner shield (10) is carried out via the stranded drain wire (1).
- The connection of the outer shield (60) is carried out via the stranded drain wire (6).

3.3.2 Notes on field current cable C



DANGER!

*A shielded 2-wire copper cable is used for the field current cable. The shielding **MUST** be connected in the housing of the flow sensor and signal converter.*



INFORMATION!

The field current cable is not part of the scope of delivery.

3.3.3 Requirements for signal cables provided by the customer

**INFORMATION!**

If the signal cable was not ordered, it is to be provided by the customer. The following requirements regarding the electrical values of the signal cable must be observed:

Electrical safety

- To EN 60811 (low voltage directive) or equivalent national regulations.

Capacitance of the insulated conductors

- Insulated conductor / insulated conductor < 50 pF/m
- Insulated conductor / shield < 150 pF/m

Insulation resistance

- $R_{iso} > 100 \text{ G}\Omega \times \text{km}$
- $U_{max} < 24 \text{ V}$
- $I_{max} < 100 \text{ mA}$

Test voltages

- Insulated conductor / inner shield 500 V
- Insulated conductor / insulated conductor 1000 V
- Insulated conductor / outer shield 1000 V

Twisting of the insulated conductors

- At least 10 twists per meter, important for screening magnetic fields.

3.4 Preparing the signal and field current cables



INFORMATION!

Assembly materials and tools are not part of the delivery. Use the assembly materials and tools in compliance with the applicable occupational health and safety directives.

3.4.1 Signal cable A (type DS 300), construction

- Signal cable A is a double-shielded cable for signal transmission between the flow sensor and signal converter.
- Bending radius: $\geq 50 \text{ mm} / 2''$

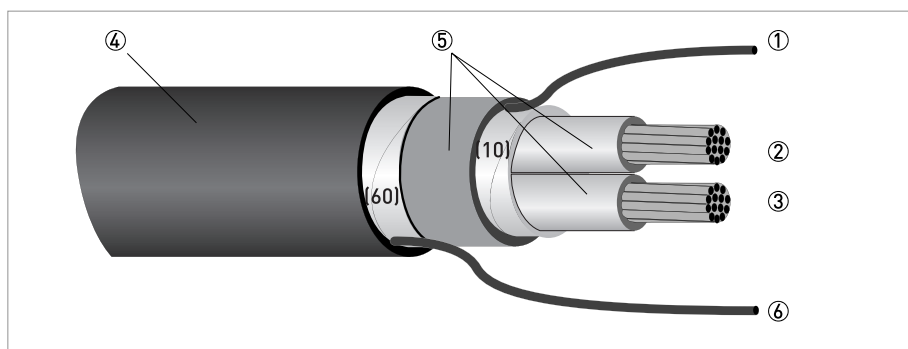

Figure 3-1: Construction of signal cable A

- ① Stranded drain wire (1) for the inner shield (10), $1.0 \text{ mm}^2 \text{ Cu}$ / AWG 17 (not insulated, bare)
- ② Insulated wire (2), $0.5 \text{ mm}^2 \text{ Cu}$ / AWG 20
- ③ Insulated wire (3), $0.5 \text{ mm}^2 \text{ Cu}$ / AWG 20
- ④ Outer sheath
- ⑤ Insulation layers
- ⑥ Stranded drain wire (6) for the outer shield (60)

3.4.2 Preparing signal cable A, connection to signal converter

**INFORMATION!**

Assembly materials and tools are not part of the delivery. Use the assembly materials and tools in compliance with the applicable occupational health and safety directives.

- Connection of the two shields in the signal converter is carried out via the stranded drain wires.
- Bending radius: $\geq 50 \text{ mm} / 2''$

Required materials

- PVC insulating tube, $\varnothing 2.5 \text{ mm} / 0.1''$
- Heat-shrinkable tubing
- 2 wire end ferrules to DIN 46 228: E 1.5-8 for the stranded drain wires (1, 6)
- 2 wire end ferrules to DIN 46 228: E 0.5-8 for the insulated conductors (2, 3)

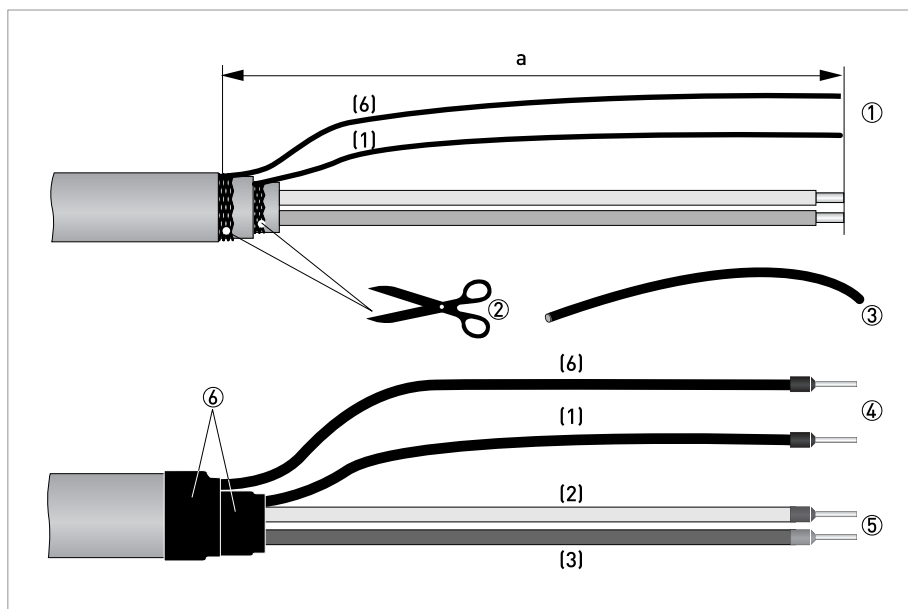

Figure 3-2: Preparation of signal cable A

$a = 80 \text{ mm} / 3.15''$



- ① Strip the conductor to dimension a.
- ② Cut off the inner shield (10) and the outer shield (60). Make sure not to damage the stranded drain wires (1, 6).
- ③ Slide the insulating tubes over the stranded drain wires (1, 6).
- ④ Crimp the wire end ferrules onto the stranded drain wire.
- ⑤ Crimp the wire end ferrules onto the conductors (2, 3).
- ⑥ Pull the heat-shrinkable tubing over the prepared signal cable.

3.4.3 Length of signal cable A



INFORMATION!

For temperatures of the medium above 150°C / 300°F, a special signal cable and a ZD intermediate socket are necessary. These are available including the changed electrical connection diagrams.

Flow sensor	Nominal size		Min. electrical conductivity [$\mu\text{S}/\text{cm}$]	Curve for signal cable A
	DN [mm]	[inch]		
OPTIFLUX 1000 F	10...150	3/8...6	20	A1
OPTIFLUX 2000 F	25...150	1...6	20	A1
	200...1200	8...48	20	A2
OPTIFLUX 4000 F	10...150	3/8...6	20	A1
	200...1200	8...48	20	A2
OPTIFLUX 6000 F	10...150	3/8...6	20	A1
WATERFLUX 3000 F	25...600	1...24	20	A1

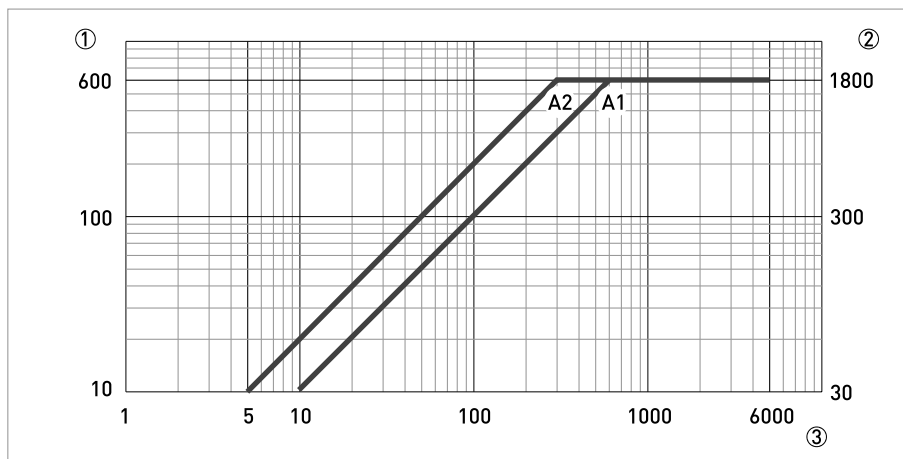

Figure 3-3: Maximum length of signal cable A

- ① Maximum length of signal cable A between the flow sensor and signal converter [m]
- ② Maximum length of signal cable A between the flow sensor and signal converter [ft]
- ③ Electrical conductivity of the medium being measured [$\mu\text{S}/\text{cm}$]

3.4.4 Preparing field current cable C, connection to signal converter

**DANGER!**

A shielded 2-wire copper cable is used as the field current cable. The shielding **MUST** be connected in the housing of the flow sensor and signal converter.

**INFORMATION!**

Assembly materials and tools are not part of the delivery. Use the assembly materials and tools in compliance with the applicable occupational health and safety directives.

- Field current cable C is not part of the scope of delivery.
- Bending radius: ≥ 50 mm / 2"

Required materials:

- Shielded, at least 2-wire copper cable with suitable heat-shrinkable tubing
- Insulating tube, size according to the cable being used
- Wire end ferrules to DIN 46 228: size according to the cable being used

Length and cross-section of field current cable C

Length		Cross-section A_F (Cu)	
[m]	[ft]	[mm ²]	[AWG]
0...150	0...492	2 x 0.75 Cu ①	2 x 18
150...300	492...984	2 x 1.5 Cu ①	2 x 14
300...600	984...1968	2 x 2.5 Cu ①	2 x 12

① Cu = copper cross-section

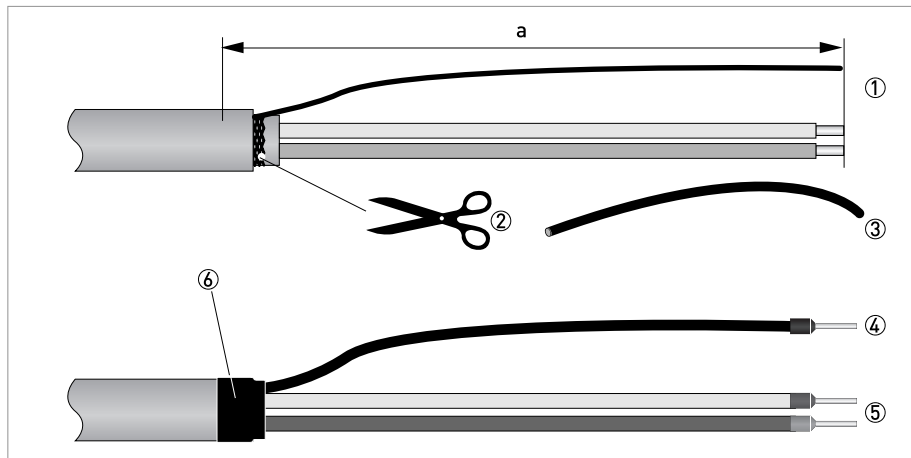

Figure 3-4: Field current cable C, preparation for the signal converter

$a = 80 \text{ mm} / 3.15''$



- ① Strip the conductor to dimension a.
- ② If a stranded drain wire is present, remove the shield that is present. Make sure not to damage the stranded drain wire.
- ③ Slide an insulating tube over the stranded drain wire.
- ④ Crimp a wire end ferrule onto the stranded drain wire.
- ⑤ Crimp the wire end ferrules on the conductors.
- ⑥ Pull a shrinkable tube over the prepared cable.

3.4.5 Preparing signal cable A, connection to flow sensor

**INFORMATION!**

Assembly materials and tools are not part of the delivery. Use the assembly materials and tools in compliance with the applicable occupational health and safety directives.

- The outer shield (60) is connected in the terminal compartment of the flow sensor directly via the shield and a clip.
- Bending radius: $\geq 50 \text{ mm} / 2''$

Required materials

- PVC insulating tube, $\varnothing 2.0 \dots 2.5 \text{ mm} / 0.08 \dots 0.1''$
- Heat-shrinkable tubing
- Wire end ferrule to DIN 46 228: E 1.5-8 for the stranded drain wire (1)
- 2 wire end ferrules to DIN 46 228: E 0.5-8 for the insulated conductors (2, 3)

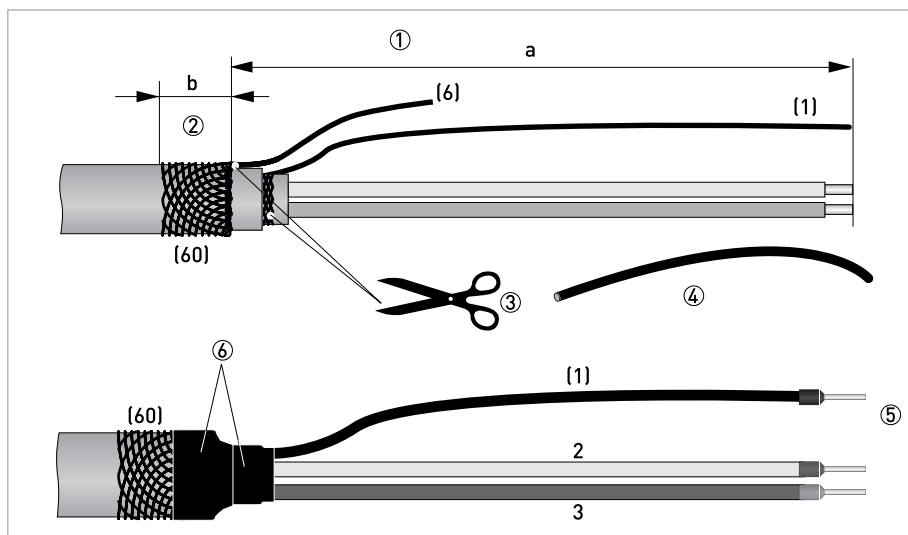

Figure 3-5: Preparing signal cable A, connection to flow sensor

$a = 50 \text{ mm} / 2''$

$b = 10 \text{ mm} / 0.4''$



- ① Strip the conductor to dimension a.
- ② Trim the outer shield (60) to dimension b and pull it over the outer sheath.
- ③ Remove the stranded drain wire (6) of the outer shield and the inner shield. Make sure not to damage the stranded drain wire (1) of the inner shield.
- ④ Slide an insulating tube over the stranded drain wire (1).
- ⑤ Crimp the wire end ferrules onto conductors 2 and 3 and the stranded drain wire (1).
- ⑥ Pull the heat-shrinkable tubing over the prepared signal cable.

3.4.6 Preparing field current cable C, connection to flow sensor



INFORMATION!

Assembly materials and tools are not part of the delivery. Use the assembly materials and tools in compliance with the applicable occupational health and safety directives.

- The field current cable is not part of the scope of delivery.
- The shield is connected in the terminal compartment of the flow sensor directly via the shield and a clip.
- Bending radius: $\geq 50 \text{ mm} / 2''$

Required materials

- Shielded 2-wire insulated copper cable
- Insulating tube, size according to the cable being used
- Heat-shrinkable tubing
- Wire end ferrules to DIN 46 228: size according to the cable being used

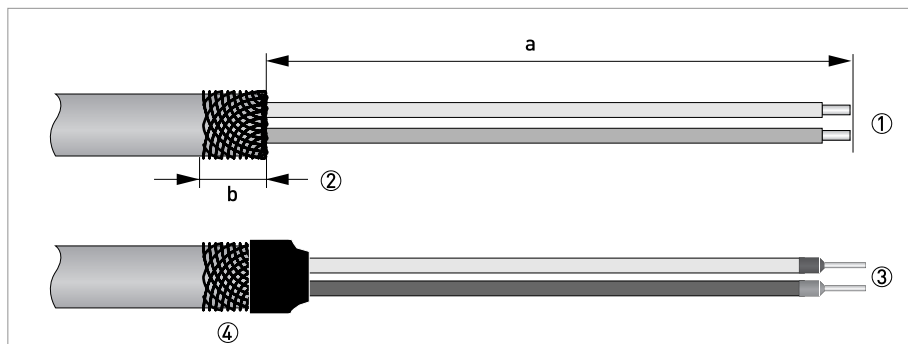

Figure 3-6: Preparation of field current cable C

$a = 50 \text{ mm} / 2''$

$b = 10 \text{ mm} / 0.4''$



- ① Strip the conductor to dimension a.
- ② Trim the outer shield to dimension b and pull it over the outer sheath.
- ③ Crimp wire end ferrules onto both conductors.
- ④ Pull a shrinkable tube over the prepared cable.

3.5 Connecting the signal and field current cables



DANGER!

Cables may only be connected when the power is switched off.



DANGER!

The device must be grounded in accordance with regulations in order to protect personnel against electric shocks.



WARNING!

Observe without fail the local occupational health and safety regulations. Any work done on the electrical components of the measuring device may only be carried out by properly trained specialists.

3.5.1 Connecting the signal and field current cables to the signal converter, remote version



INFORMATION!

The compact version is supplied pre-assembled from the factory.



Connect the electrical conductors as follows:

- ① Press with a screwdriver in the slot on the spring terminal.
- ② Insert the electrical conductor into the plug.
- ③ The conductor will be clamped as soon as the screwdriver is pulled out of the slot.

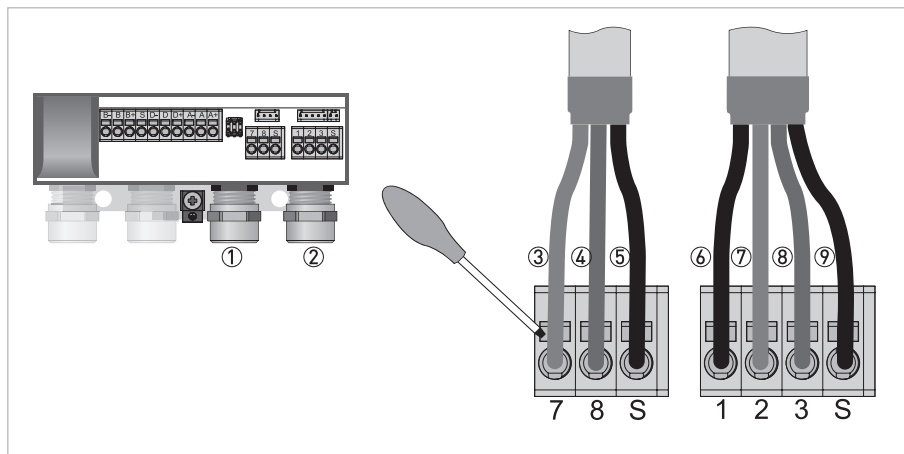

Figure 3-7: Connecting the signal and field current cables

- ① Cable entry for field current cable
- ② Cable entry for signal cable
- ③ Electrical conductor (7)
- ④ Electrical conductor (8)
- ⑤ Connecting the field current cable shield
- ⑥ Stranded drain wire (1) of the inner shield (10) of the signal cable
- ⑦ Electrical conductor (2)
- ⑧ Electrical conductor (3)
- ⑨ Stranded drain wire (S) of the outer shield (60)

3.5.2 Connection diagram for signal and field current cable



DANGER!

The device must be grounded in accordance with regulations in order to protect personnel against electric shocks.

- A shielded 2-wire copper cable is used as the field current cable. The shielding **MUST** be connected in the housing of the flow sensor and signal converter.
- The outer shield (60) is connected in the terminal compartment of the flow sensor directly via the shield and a clip.
- Bending radius of signal and field current cable: $\geq 50 \text{ mm} / 2''$
- The following illustration is schematic. The positions of the electrical connection terminals may vary depending on the housing version.

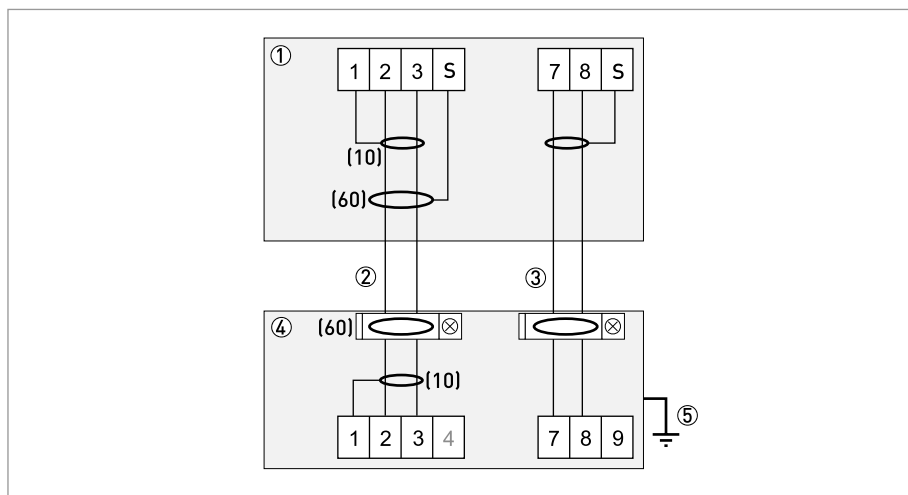

Figure 3-8: Connection diagram for signal and field current cable

- ① Electrical terminal compartment in the signal converter
- ② Signal cable A
- ③ Field current cable C
- ④ Electrical terminal compartment in the flow sensor
- ⑤ Functional ground FE

3.6 Grounding the flow sensor

**CAUTION!**

There should be no difference in potential between the flow sensor and the housing or protective earth of the signal converter!

- The flow sensor must be properly grounded.
- The grounding cable should not transmit any interference voltages.
- Do not use the grounding cable to connect any other electrical devices to ground at the same time.
- The flow sensors are connected to ground by means of a functional grounding conductor FE.
- Special grounding instructions for the various flow sensors are provided in the separate documentation for the flow sensor.
- The documentation for the flow sensor also contain descriptions on how to use grounding rings and how to install the flow sensor in metal or plastic pipes or in pipes which are coated on the inside.

3.7 Connecting the power supply

**DANGER!**

- *To protect operators from electrical shock, during installation the cable for the power supply **must** be run with sheathing insulation up to the mains cover. The insulated individual wires have to be only below the mains cover!*
- *If there is no mains cover or if it has been lost, the 100...230 VAC device may only be operated from the outside (with a magnet pencil) while closed!*
- The housings of the devices, which are designed to protect the electronic equipment from dust and moisture, should be kept well closed at all times. Creepage distances and clearances are dimensioned to VDE 0110 and IEC 664 for pollution severity 2. Supply circuits are designed for overvoltage category III and the output circuits for overvoltage category II.
- Fuse protection ($I_N \leq 16$ A) for the infeed power circuit, and also a separator (switch, circuit breaker) to isolate the signal converter must be provided.

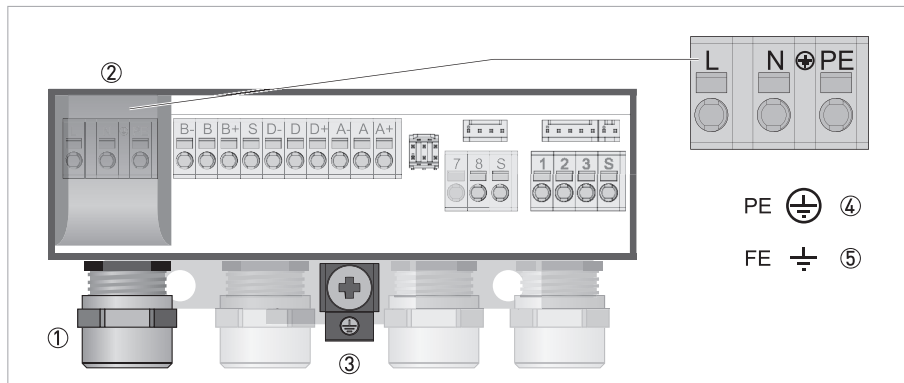

Figure 3-9: Terminal compartment for power

- ① Cable entry for power supply
- ② Mains cover
- ③ Ground terminal
- ④ 100...230 VAC (-15% / +10%)
- ⑤ 24 VDC (-30% / +30%)



- To open the cover of the electrical terminal compartment, lightly press in the side walls of the mains cover ②.
- Flip the mains cover up.
- Connect the power supply.
- Close the mains cover again by flipping it down.

100...230 VAC (tolerance range: -15% / +10%)

- Note the power supply voltage and frequency (50...60 Hz) on the nameplate.



INFORMATION!

240 VAC + 5% is included in the tolerance range.

24 VDC (tolerance range: -30% / +30%)

- Note the data on the nameplate!
- When connecting to functional extra-low voltages, provide a facility for protective separation (PELV) (acc. to VDE 0100 / VDE 0106 and/or IEC 364 / IEC 536 or relevant national regulations).

3.8 Inputs and outputs, overview

3.8.1 Description of the CG number



Figure 3-10: Marking (CG number) of the electronics module and output variants

- ① ID number: 0
- ② ID number: 0 = standard; 9 = special
- ③ Power supply
- ④ Display (language versions)
- ⑤ Output version

3.8.2 Fixed, non-alterable output versions

This signal converter is available with various output combinations.

- The grey boxes in the tables denote unassigned or unused connection terminals.
- In the table, only the final digits of the CG no. are depicted.
- Terminals D- and A- are connected for active pulse/frequency output (no galvanic isolation anymore).
- Available are an active or passive pulse/frequency output, or the active or passive status/limit output. It's not possible to use both at the same time!

Basic outputs (I/Os)

CG no.	Connection terminals						
	S	D-	D	D+	A-	A	A+
1 0 0 R 0 0	①	P _p / S _p passive			I _p + HART® passive ②		
		connected to A-	P _a active		connected to D-	I _a + HART® active ②	
		P _p / S _p passive			I _a + HART® active ②		

① Shielding

② Function changed by reconnecting

Modbus (I/O) (option)

CG no.	Connection terminals			
	B-	B	B+	S
R 0 0	Sign. A (D0-)	Common	Sign. B (D1+)	Shielding

Description of used abbreviations

I _a	I _p	Current output active or passive
P _a	P _p	Pulse/frequency output active or passive
S _a	S _p	Status output/limit switch active or passive

3.9 Electrical connection of the outputs



INFORMATION!

Assembly materials and tools are not part of the delivery. Use the assembly materials and tools in compliance with the applicable occupational health and safety directives.

3.9.1 Electrical connection of the outputs



DANGER!

All work on the electrical connections may only be carried out with the power disconnected. Take note of the voltage data on the nameplate!

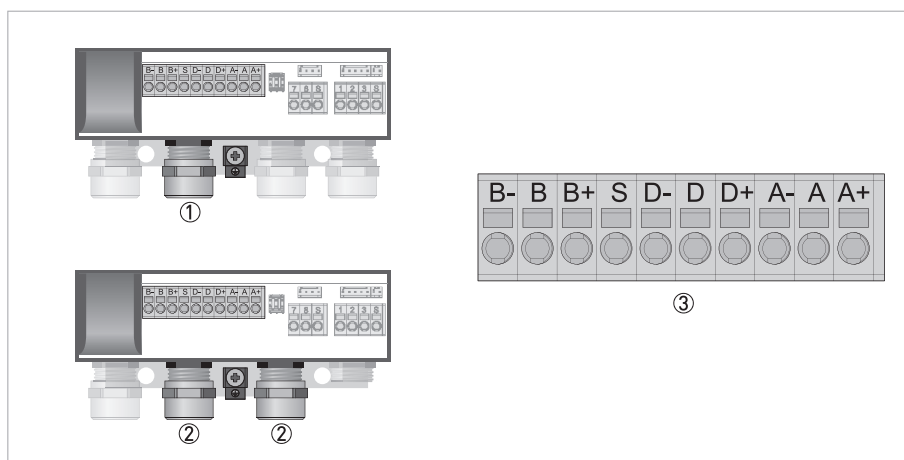

Figure 3-11: Electrical connection of the outputs

- ① Cable entry, remote version
- ② Cable entry, compact version (right cable entry is optional)
- ③ Terminal block for the connection of outputs



- Open the housing cover
- Push the prepared cables through the cable entries and connect the necessary conductors.
- Connect the shield.
- Close the housing cover.



INFORMATION!

Ensure that the housing gasket is properly fitted, clean and undamaged.

3.9.2 Laying electrical cables correctly

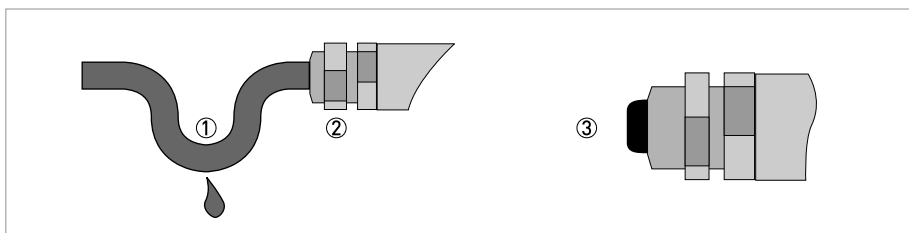

Figure 3-12: Protect housing from dust and water



- ① For compact versions with nearly horizontally-oriented cable entries, lay the necessary electric cables with a drip loop as shown in the illustration.
- ② Tighten the screw connection of the cable entry securely.
- ③ Seal cable entries that are not needed with a plug.

4.1 Switching on the power

Before connecting to power, please check that the system has been correctly installed. This includes:

- The device must be mechanically safe and mounted in compliance with the regulations.
- Remove the bar magnet and keep it on a safe place (is only valid for the display version).
- The power connections must have been made in compliance with the regulations.
- The electrical terminal compartments must be secured and the covers have been screwed on.
- Check that the electrical operating data of the power supply are correct.



- Switching on the power.

4.2 Starting the signal converter

The measuring device, consisting of the flow sensor and the signal converter, is supplied ready for operation. All operating data have been set at the factory in accordance with your order specifications.

When the power is switched on, a self test is carried out. After that the device immediately begins measuring, and the current values are displayed.

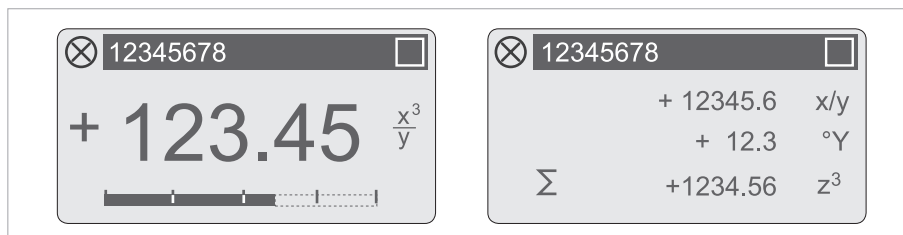

Figure 4-1: Displays in measuring mode (examples for 2 or 3 measured values)
x, y and z denote the units of the measured values displayed

It is possible to change between the two measured value windows, the trend display and the list with the status messages by pressing the keys \uparrow and \downarrow .







KROHNE – Process instrumentation and measurement solutions

- Flow
- Level
- Temperature
- Pressure
- Process Analysis
- Services

Head Office KROHNE Messtechnik GmbH
Ludwig-Krohne-Str. 5
47058 Duisburg (Germany)
Tel.: +49 203 301 0
Fax: +49 203 301 10389
info@krohne.com

The current list of all KROHNE contacts and addresses can be found at:
www.krohne.com

KROHNE