



UFC 400 Supplementary instructions

Signal converter for ultrasonic flowmeters

Description of PROFIBUS interface

PROFIBUS PA:

PROFIBUS device with MBP Physical Interface and PA Profile 3.02 (V2.2.3_ / 140430)

PROFIBUS DP:

PROFIBUS device with RS485 Physical Interface and PA Profile 3.02 (V2.2.3_ / 140430)



The documentation is only complete when used in combination with the relevant documentation for the flow sensor.

1	Safety instructions	4
<hr/>		
1.1	Scope of the document.....	4
1.2	Scope of delivery.....	4
1.3	Special notes	4
2	PROFIBUS DP	5
<hr/>		
2.1	Software history	5
2.2	System configuration of PROFIBUS DP network.....	5
2.3	Electrical connection for DP signal converter	6
2.4	Technical data.....	8
2.5	PROFIBUS PA Profile implementation	9
2.6	GSD files	9
2.7	Ident. Number selector	10
2.8	Summary	13
2.9	Baud rate	14
3	PROFIBUS PA	15
<hr/>		
3.1	Software history	15
3.2	System configuration of PROFIBUS PA network	16
3.3	Electrical connection for PA signal converter	17
3.4	Technical data.....	18
3.5	PROFIBUS PA Profile implementation	19
3.6	GSD files	19
3.7	Ident. Number selector	20
3.8	Summary	23
4	Commissioning / Operation	24
<hr/>		
4.1	Configuration of cyclic data transfer.....	24
4.2	Cyclic data.....	24
4.2.1	Input data	24
4.2.2	Output data.....	30
4.3	Diagnosis	31
4.3.1	Mapping of DIAGNOSIS_EXTENSION bits into DIAGNOSIS bits if "Condensed Status and Diagnosis" handling selected	37
4.3.2	Mapping of DIAGNOSIS_EXTENSION bits into DIAGNOSIS bits if "Classic Status and Diagnosis" handling selected	40
4.3.3	Variable "Event groups"	42
4.3.4	Filtering of "Single events"	44

5 Profibus settings	45
5.1 Menu A, Quick Setup	45
5.2 Menu B, Test	45
5.3 Menu C, Setup.....	46
5.4 Menu D, Service	50
5.5 Status messages and diagnostic information.....	51
6 Notes	53

1.1 Scope of the document

These instructions are supplementary to the signal converter Handbook. For all other data, use the relevant chapters of the Handbook. If you do not have this document, please contact the nearest office or download them from the manufacturer's internet site.



INFORMATION!

The information in this chapter only contains the data applicable to PROFIBUS communication. The technical data in the Handbook shall be valid in its current version, provided that it is not rendered invalid or replaced by this supplement.

1.2 Scope of delivery

The information in this chapter only contains the data applicable to PROFIBUS communication. The technical data in the Handbook shall be valid in its current version, provided that it is not rendered invalid or replaced by this supplement.

A device for PROFIBUS communication is supplied with:

- Supplementary instructions for PROFIBUS communication
- PROFIBUS device data files (GSD) which can be also downloaded from the manufacturer's internet site

1.3 Special notes

Don't switch off (power off) the signal converter immediately after manual change of parameter values:

- Please wait approx. 10 seconds before you switch off the signal converter after you have done both a parameter download via PROFIBUS or a manual change of a parameter value via the local display.



CAUTION!

Please wait approx. 15 seconds before you switch off the signal converter after you have carried out a "Factory Reset" (PROFIBUS "Coldstart") via PROFIBUS or local display.

"Deactivation of the Service Parameter Lock" of the signal converter via PROFIBUS:

- After writing down the service password (via PROFIBUS) the "Deactivation of the Service Parameter Lock" will last at least 20 minutes if the internal password timer of the signal converter won't be retriggered by writing this password again. The "Deactivation of the Service Parameter Lock" will be terminated at once by a PROFIBUS Coldstart / Warmstart or if the internal password timer of the signal converter elapsed.

2.1 Software history

Issued	Signal converter		Application program		System integration		
Mth./year	Hardware	Firmware	Hardware	Software	Driver	Version	Model name
04/14	Signal converter with RS485 interface + PA Profile 3.02	V2.2.3_ / 140430	Simatic PCS7	HW Config	GSD manuf. specific	KR014520.GSD	UFC400 (RS485) Rev.1
			other SPS of other manufact.	other Software of other SPS manufact.	GSD profile specific	PA039741.GSD	Flow 2AI, 1TOT (Phy RS-485)
			Laptop / PC	PDM (≥ 6.1)	DD	UFC400 PROFIBUS DD 0101 PDM 6.x-8.x	-
			Pactware		DTM ≥	U3P* DTM 1.0.2 FDT 1.2	-

The PROFIBUS DP device has a RS485 interface to connect the device to a PROFIBUS DP network.

The software supports the PROFIBUS PA Profile 3.02. Both, cyclic services towards a control system (e.g. PLC) as well as acyclic services for operating with engineering tools (e.g. DD/DTM based tools) are supported.

The PROFIBUS station address can be set via PROFIBUS services or via the device display.

2.2 System configuration of PROFIBUS DP network

The following diagram shows a typical network configuration with PROFIBUS devices with RS485 interface in a non-hazardous environment. The PROFIBUS devices with RS485 interface do not need any segment coupler. They are connected directly to the PROFIBUS DP network.

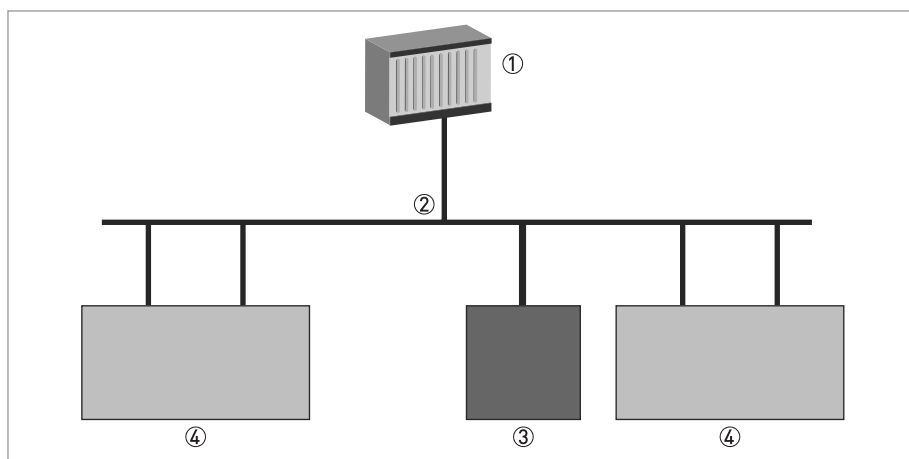

Figure 2-1: PROFIBUS DP network

- ① SPS
- ② PROFIBUS DP network with max. 12 Mbit/s
- ③ Signal converter
- ④ Other devices with PROFIBUS RS485 interface

2.3 Electrical connection for DP signal converter



INFORMATION!

For a detailed description of the electrical connections please refer to the standard signal converter handbook.

Signal converter terminals	B	B-	C	C-	D	D-
PROFIBUS designation	T	+B	-A	-T	+B	-A
	①	②	③	④	⑤	⑥

- ① Termination positive
- ② TxD+/RxD+ second connection
- ③ TxD-/RxD- second connection
- ④ Termination negative
- ⑤ TxD+/RxD+ first connection
- ⑥ TxD-/RxD- first connection

External connection with spur

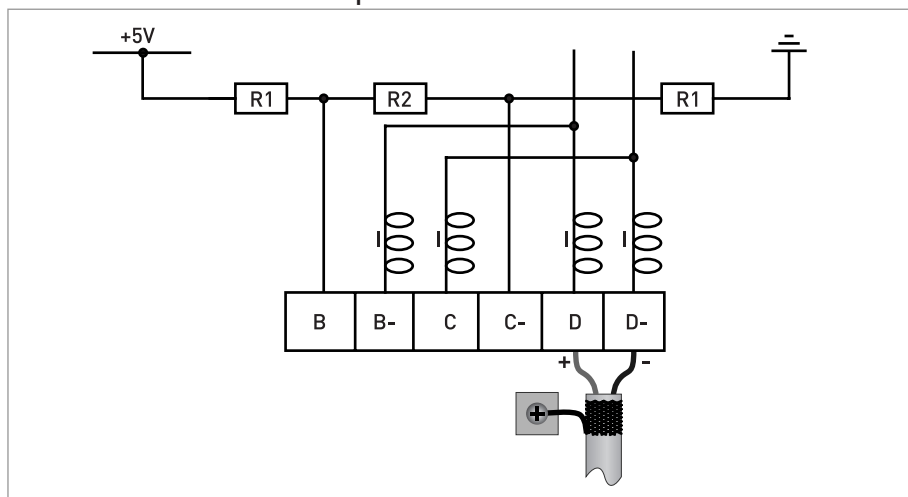

CAUTION!

Spurs are not allowed at high data rates!

$l = 110 \text{ nH}$
 $R1 = 390 \ \Omega$
 $R2 = 220 \ \Omega$

External connection at last device with active internal bus termination

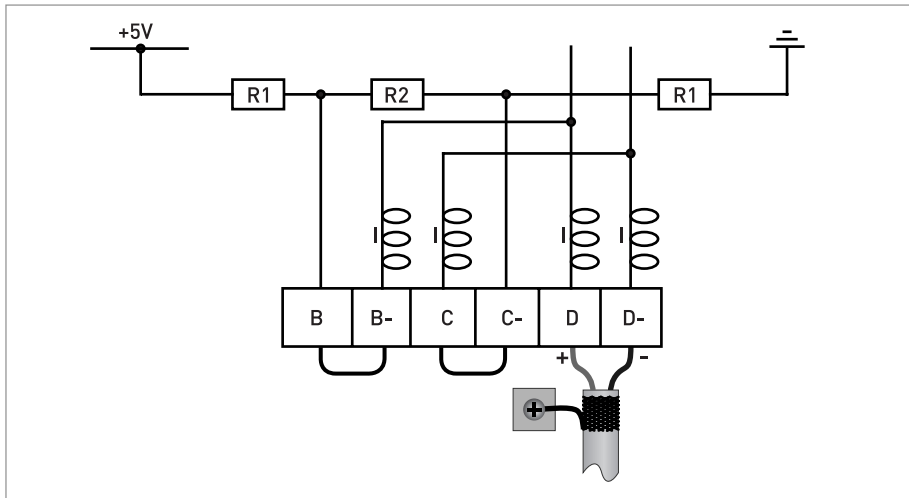

$I = 110 \text{ nH}$
 $R1 = 390 \ \Omega$
 $R2 = 220 \ \Omega$

External connection to a trunk

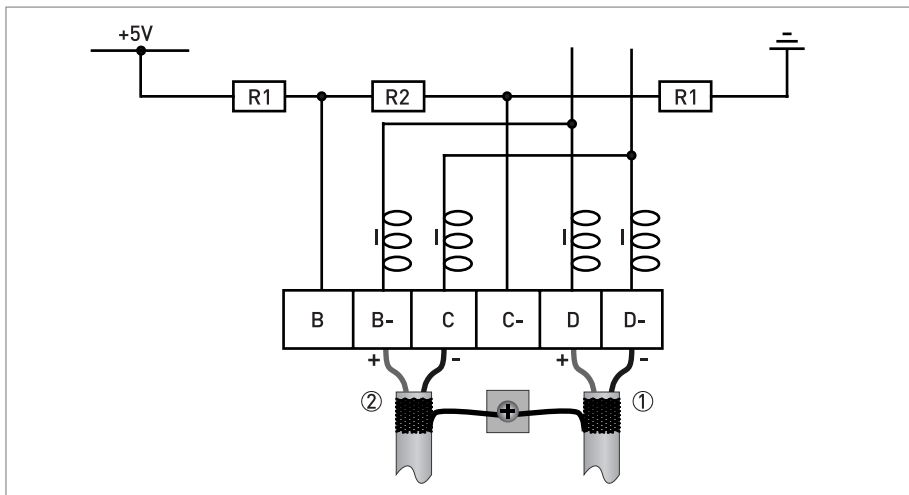

- ① e.g. incoming data lines
- ② e.g. outgoing data lines

$I = 110 \text{ nH}$
 $R1 = 390 \ \Omega$
 $R2 = 220 \ \Omega$

2.4 Technical data

Hardware

Type	PROFIBUS RS485 interface according to IEC 61158-2
Connection	Dependent of polarity; please note at electrical connection!

Software

GSD	GSD file on CD-ROM or from internet site
	Supported GSD: <ul style="list-style-type: none"> • KR014520.GSD • PA039741.GSD
Device profile	PROFIBUS PA Profile 3.02; conformance class B, compact
Address range	0...126 (default 126)
	0...125 via PROFIBUS service set_slave_add
	0...126 via local display
	126 via factory_reset = 2712
Local control	Local display and operator interface at device
SAPs	2 x MS1 SAPs – acyclic interface to PLC
	3 x MS2 SAPs – the number of MS2 Service Access Points is typically equal to the maximum number of master class 2 tools
Function blocks	1 x TB = Transducer Block
	1 x PB = Physical Block
	6 x AI = Analog Input Blocks
	3 x TOT = Totalizer Function Blocks

2.5 PROFIBUS PA Profile implementation

The PROFIBUS PA Profile 3.02 defines standardized parameters and functions for PROFIBUS devices used for process control. It describes a PROFIBUS device as a function block application, i.e. parameters and functions are grouped into different blocks. In the UFC 400 PROFIBUS device the following blocks are implemented:

Block	Usage
1 Physical Block (PB)	contains identification and diagnosis parameters of the device
1 Flow Transducer Block (TB)	contains parameters and functions to control the flow measurement
6 Analog Input Function Block (AI-FB)	contains parameters and functions to control the measuring output; provides the measuring value(s)
3 Totalizer Function Blocks (TOT-FB)	contains parameters and functions to control/provide the counter value(s)

The Analog Input Function Blocks and the Totalizer Function Blocks provide the data interface towards a process control system (e.g. a PLC); i.e. their input/output data can be read/written by the control system. In a PROFIBUS network this is done via cyclic communication services.

From the PROFIBUS point of view the UFC 400 device is designed as a compact device with 9 slots. While the Analog Input function blocks are assigned to slot 1, 2, 6, 7, 8 and 9 the Totalizer Function Blocks are assigned to slot 3, 4 and 5. This assignment is fixed and cannot be modified by the user. Nevertheless during network configuration the user can choose which function block data shall be transferred between the PROFIBUS master and the PROFIBUS device.

2.6 GSD files

The GSD file contains information that will be needed for configuration of the PROFIBUS DP communication network. Supplementary files (e.g. ____.bmp and ____.dib) contain icons which will represent the PROFIBUS devices in the view of the bus configuration system/master system. The files must be loaded into the configuration program before. Follow the instructions in the manual of the host supplier when installing GSD file and supplementary files.

A PROFIBUS GSD ZIP file including both all GSD files of all KROHNE devices with PROFIBUS PA interface and all additional data files mentioned above are available at the KROHNE download page.



INFORMATION!

If it is supported by the host configuration tool the device entry for the UFC400 PROFIBUS device will be located within the slave family "PROFIBUS PA".

2.7 Ident. Number selector

Within a PROFIBUS network the type of a PROFIBUS slave is identified by its Ident. Number which is unique for this slave type. The PROFIBUS DP device supports two different Ident. Numbers. Therefore it can be installed for different use cases. When the Ident. Number is changed the behaviour of the device concerning the cyclic data transfer is changed; i.e. the maximum number of transferred measuring values and/or the length and content of the diagnosis information will be different. The user can select the required Ident. Number by an engineering tool (e.g. DD/DTM - parameter IDENT_NUMBER_SELECTOR slot 0; index 40) or via the UFC 400 device display menu (menu item "Identification No.", C5.8.6).

The following settings are supported:

- Automatic adaptation mode (factory setting)
- Manufacturer specific Ident. Number (UFC400)
- Profile specific Ident. Number (Profile)

Automatic adaptation mode (factory setting)

If the parameter IDENT_NUMBER_SELECTOR is set to this mode the device will select its operation mode during start-up of the cyclic data transfer according to the used GSD file. The active Ident. Number is set to one of the settings described below. If the IDENT_NUMBER_SELECTOR is changed to this mode the current Ident. Number is not changed until the cyclic data transfer is (re-)started.



INFORMATION!

Depending on the components in the PROFIBUS network the automatic adaptation might fail. In this case the active Ident. Number has to be selected by the user via an engineering tool or via the device display menu. The parameter IDENT_NUMBER_SELECTOR has to be set to a fixed Ident. Number.

Manufacturer specific Ident. Number (4520 hex)

This setting provides complete functionality of the PROFIBUS DP device. All Function Blocks are available for cyclic data transfer. Device specific diagnosis information is transferred in addition to the Profile diagnosis.

Cyclic layout:

Slot	Description	Function Block types	Default unit
1	Volume Flow	AI-FB	m ³ /h
2	Velocity of Sound	AI-FB	m/s
3	Volume total	Totaliser-FB	m ³
4	Volume total	Totaliser-FB	m ³
5	Mass total	Totaliser-FB	kg
6	Mass Flow	AI-FB	kg/s
7	Flow speed	AI-FB	m/s
8	Gain	AI-FB	dB
9	SNR	AI-FB	dB

- AI: Analog Input Function Block
- FB: Function Block

There are separate settings to select the units for local display and PROFIBUS. Modifications of the units of the display will have no effect on the data transferred via PROFIBUS. A master class 2 tool is required to modify the units for PROFIBUS transfer.

Valid GSD Modules:

AI-FB	Empty Module AI: Out
Totaliser-FB	Empty Module TOT (Id.F.): Total TOT (Id.F.): SetTot + Total TOT (Id.F.): ModeTot + Total TOT (Id.F.): SetTot+ModeTot+Total TOT (Id.F.): SetTot TOT (Id.F.): ModeTot TOT (Id.F.): SetTot + ModeTot

GSD File required:

GSD file **KR014520.GSD** is required in this mode. This GSD file provides complete functionality of the PROFIBUS DP device. All function blocks are available for cyclic data transfer.



INFORMATION!

If another GSD file is used in the PROFIBUS master system the cyclic data transfer cannot be established in this setting.

**INFORMATION!**

During network configuration the user has to define which function block outputs of the signal converter should be transferred cyclically to the master. This is performed by a bus configuration tool (e.g. "HW- Config" for PC-S7 from Siemens). This tool offers specific functions as follows:

- 1. It is possible to configure an "Empty" block (the code of an "Empty" block is defined as 0x00) on each block number. This implies: no data is transmitted in the cyclic data telegram for this block.*
- 2. There is NO "Totaliser (TOT)" function block allowed on block position 1, 2, 6, 7, 8 and 9! On these positions, only an "Analog Input (AI)" function block or an "Empty" block is allowed! (Note: All codes supported by "Analog Input (AI)" - and "Totaliser (TOT)" - function blocks will be found in the corresponding GSD files.)*
- 3. There is NO "Analog Input (AI)" function block allowed on block position 3, 4 and 5! On these positions, only a "Totaliser (TOT)" function block or an "Empty" block is allowed!*
- 4. There is a choice of 7 different totaliser functions, which can be allocated to the blocks 3, 4 and/or 5.*

Profile specific Ident. Number (9741 hex)

Functionality is reduced to the requirements which are mandatory in the PA Profile; e.g. 2 x AI-FB and 1 x TOT-FB are available for cyclic data transfer only. Device specific diagnosis information is not available via cyclic PROFIBUS services. Nevertheless this behaviour will improve interchangeability between devices of different vendors because only functions are available which are provided by all PROFIBUS PA ultrasonic flowmeters. Exchange is possible without modifying the configuration of the control system.

Cyclic layout:

Slot	Description	Function Block type	Default unit
1	Volume Flow	AI-FB	m ³ /h
2	Velocity of Sound	AI-FB	m/s
3	Totaliser	Totaliser-FB	m ³

Valid GSD Modules:

AI-FB	EMPTY_MODULE AI
Totaliser-FB	EMPTY_MODULE TOTAL SETTOT_TOTAL SETTOT_MODETOT_TOTAL

GSD File required:

GSD file **PA039741.GSD** is required in this mode. This file is provided by PROFIBUS International. Take care that "Condensed Status and Diagnosis" is not supported by this file.



INFORMATION!

If another GSD file is used in the PROFIBUS master system the cyclic data transfer cannot be established in this setting.

2.8 Summary

The following table shows a summary of the supported combinations of the PROFIBUS device with RS485 Physical Interface and PA Profile 3.02:

Ident. Number Selector	Ident. Number	GSD File	Status
Automatic adaptation mode	4520	KR014520.GSD	Classic / Condensed
	9741	PA039741.GSD ①	Classic
Manufacturer specific Ident. Number	4520	KR014520.GSD	Classic / Condensed
Profile specific Ident. Number	9741	PA039741.GSD ①	Classic

① This file is provided by PROFIBUS International (www.profibus.com). Take care that "Condensed Status and Diagnosis" is not supported by this file.

2.9 Baud rate

Supported baud rates are listed in the GSD file. After power-on or PROFIBUS timeout a baud rate search is active to detect the current transfer speed on the bus. It is not necessary to set the baud rate manually.

If the data transmission rate is changed during operation the baud rate search will not be started by the device. A new power-up or a manual interruption of the PROFIBUS communication is required to activate the baud rate search in this case.

3.1 Software history

Issued	Signal converter		Application program		System integration		
Mth./year	Hardware	Firmware	Hardware	Software	Driver	Version	Model name
10/13	Signal converter with MBP interface + PA Profile 3.02	V1.0.1_ / 131031	Simatic PCS7	HW Config	GSD manuf. specific	KR014521.GSD	UFC400 (MBP) Rev.1
			other SPS of other manufact.	other Software of other SPS manufact.	GSD profile specific	PA139741.GSD	Flow, 2AI, 1TOT (Phy MBP)
			Laptop / PC	PDM (≥ 6.1)	DD	UFC400 PROFIBUS DD 0101 PDM 6.x-8.x	-
			PACTware	DTM ≥	U3P* DTM 1.0.2 FDT 1.2	-	
04/14	Signal converter with RS485 interface + PA Profile 3.02	V2.2.3_ / 140430	Simatic PCS7	HW Config	GSD manuf. specific	KR014521.GSD	UFC400 (MBP) Rev.1
			other SPS of other manufact.	other Software of other SPS manufact.	GSD profile specific	PA139741.GSD	Flow, 2AI, 1TOT (Phy MBP)
			Laptop / PC	PDM (≥ 6.1)	DD	UFC400 PROFIBUS DD 0101 PDM 6.x-8.x	-
			Pactware	DTM ≥	U3P* DTM 1.0.2 FDT 1.2	-	

3.2 System configuration of PROFIBUS PA network

The following diagram shows a typical instrumentation with PROFIBUS PA devices with MBP interface in hazardous and non-hazardous locations, including connections of conventional devices (e.g. with 4...20 mA signals) in a PROFIBUS network.

As a rule, the PROFIBUS PA segment is connected to a segment coupler which, among other things, carries out the conversion to the PROFIBUS DP bus line. It should be mentioned that the segment coupler is normally set to a fixed baud rate on the DP side.

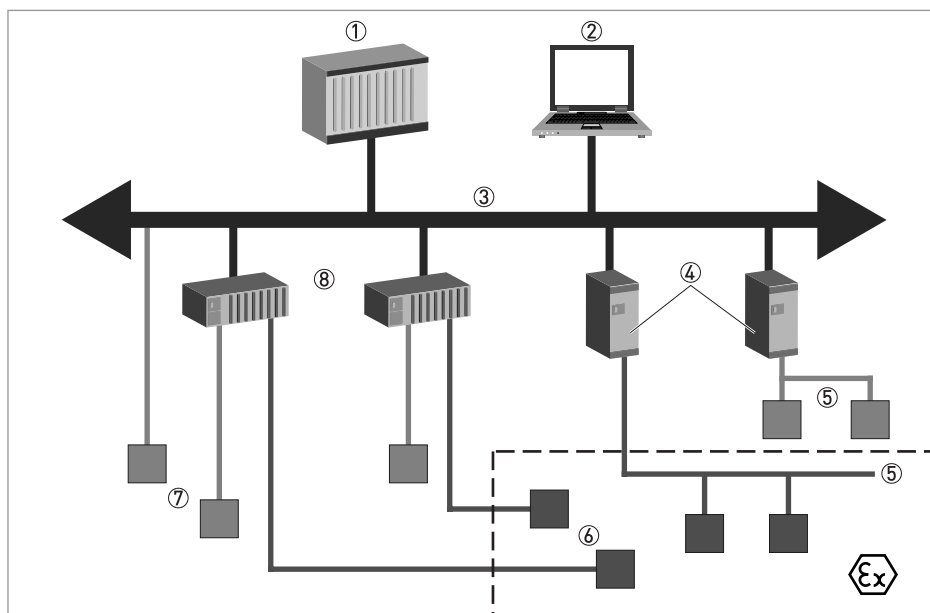

Figure 3-1: PROFIBUS PA network

- ① Control system (PLC); class 1 master
- ② Engineering or operation control tool; class 2 master
- ③ PROFIBUS DP network with max. 12 Mbit/s
- ④ PROFIBUS PA segment coupler DP / PA
- ⑤ PROFIBUS PA network with 31.25 kbit/s
- ⑥ HART® device
- ⑦ More devices with 4...20 mA
- ⑧ Analogue I/O module

3.3 Electrical connection for PA signal converter



INFORMATION!

The wiring between the device and the PROFIBUS PA bus is independent of polarity. The signal converter PROFIBUS PA interface will operate only if the additional power supply for the device is connected/available.

For a detailed description of the electrical connections please refer to the standard signal converter handbook. Refer also to the PROFIBUS PA user and installation guideline (Version 2.2, February 2003 PNO order no. 2.092).

Connection to a spur

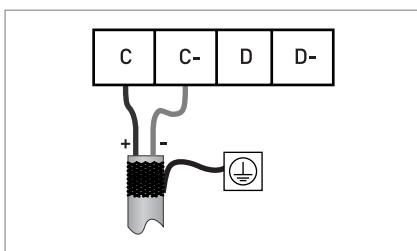

or

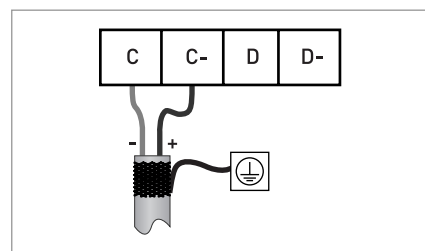

Connection to a trunk

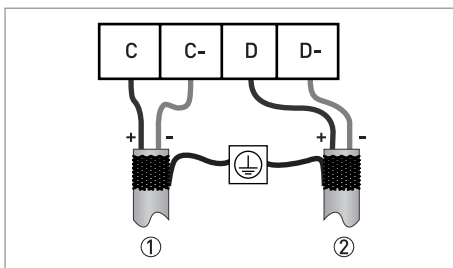

or

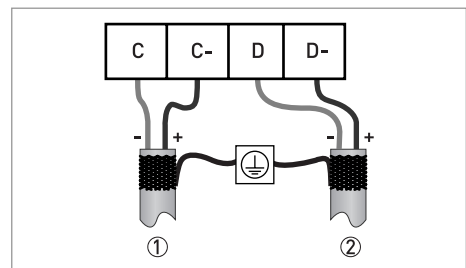

- ① e.g. incoming data lines
- ② e.g. outgoing data lines

3.4 Technical data

Hardware

Type	PROFIBUS MBP interface according to IEC 61158-2 with 31.25 kbits/s; voltage mode [MBP = Manchester Coded Bus Powered]
Connection	Independent of polarity at electrical connection
Base current	10.5 mA
FDE	Yes, separate fault disconnection electronics provided (FDE = Fault Disconnection Electronics)
Fault current	6 mA (fault current = max. continuous current – base current)
Starting current	<12 mA
Ex approval	Ex ia IIC or Ex ib IIC/IIB, FISCO Device For detailed information refer to standard product documentation.

Software

GSD	GSD file on CD-ROM or from internet site
	Supported GSD: <ul style="list-style-type: none"> • KR014521.GSD • PA139741.GSD
Device profile	PROFIBUS PA Profile 3.02; conformance class B, compact
Address range	0...126 (default 126)
	0...125 via PROFIBUS service set_slave_add
	0...126 via local display
	126 via factory_reset = 2712
Local control	Local display and operator interface at device
SAPs	2 x MS1 SAPs – acyclic interface to PLC
	3 x MS2 SAPs – the number of MS2 Service Access Points is typically equal to the maximum number of master class 2 tools
Function blocks	1 x TB = Transducer Block
	1 x PB = Physical Block
	6 x AI = Analog Input Blocks
	3 x TOT = Totalizer Function Blocks

3.5 PROFIBUS PA Profile implementation

The PROFIBUS PA Profile 3.02 defines standardized parameters and functions for PROFIBUS devices used for process control. It describes a PROFIBUS device as a function block application, i.e. parameters and functions are grouped into different blocks. In the UFC 400 PROFIBUS device the following blocks are implemented:

Block	Usage
1 Physical Block (PB)	contains identification and diagnosis parameters of the device
1 Flow Transducer Block (TB)	contains parameters and functions to control the flow measurement
6 Analog Input Function Block (AI-FB)	contains parameters and functions to control the measuring output; provides the measuring value(s)
3 Totalizer Function Blocks (TOT-FB)	contains parameters and functions to control/provide the counter value(s)

The Analog Input Function Block and the Totalizer Function Blocks provide the data interface towards a process control system (e.g. a PLC); i.e. their input/output data can be read/written by the control system. In a PROFIBUS network this is done via cyclic communication services.

From the PROFIBUS point of view the UFC 400 device is designed as a compact device with 9 slots. While the Analog Input function blocks are assigned to slot 1, 2, 6, 7, 8, 9 the Totalizer Function Blocks are assigned to slot 3, 4 and 5. This assignment is fixed and cannot be modified by the user. Nevertheless during network configuration the user can choose which function block data shall be transferred between the PROFIBUS master and the PROFIBUS device.

3.6 GSD files

The GSD file contains information that will be needed for configuration of the PROFIBUS DP communication network. Supplementary files (e.g. ____.bmp and ____.dib) contain icons which will represent the PROFIBUS devices in the view of the bus configuration system/master system. The files must be loaded into the configuration program before. Follow the instructions in the manual of the host supplier when installing GSD file and supplementary files.

A PROFIBUS GSD ZIP file including both all GSD files of all KROHNE devices with PROFIBUS PA interface and all additional data files mentioned above are available at the KROHNE download page.



INFORMATION!

If it is supported by the host configuration tool the device entry for the UFC400 PROFIBUS device will be located within the slave family "PROFIBUS PA".

3.7 Ident. Number selector

Within a PROFIBUS network the type of a PROFIBUS slave is identified by its Ident. Number which is unique for this slave type. The PROFIBUS PA device supports two different Ident. Numbers. Therefore it can be installed for different use cases. When the Ident. Number is changed the behaviour of the device concerning the cyclic data transfer is changed; i.e. the maximum number of transferred measuring values and/or the length and content of the diagnosis information will be different. The user can select the required Ident. Number by an engineering tool (e.g. DD/DTM - parameter IDENT_NUMBER_SELECTOR slot 0; index 40) or via the UFC 400 device display menu (menu item "Identification No.", C5.8.6).

The following settings are supported:

- Automatic adaptation mode (factory setting)
- Manufacturer specific Ident. Number (UFC400)
- Profile specific Ident. Number (Profile)

Automatic adaptation mode (factory setting)

If the parameter IDENT_NUMBER_SELECTOR is set to this mode the device will select its operation mode during start-up of the cyclic data transfer according to the used GSD file. The active Ident. Number is set to one of the settings described below. If the IDENT_NUMBER_SELECTOR is changed to this mode the current Ident. Number is not changed until the cyclic data transfer is (re-)started.



INFORMATION!

Depending on the components in the PROFIBUS network the automatic adaptation might fail. In this case the active Ident. Number has to be selected by the user via an engineering tool or via the device display menu. The parameter IDENT_NUMBER_SELECTOR has to be set to a fixed Ident. Number.

Manufacturer specific Ident. Number (4521 hex)

This setting provides complete functionality of the PROFIBUS PA device. All Function Blocks are available for cyclic data transfer. Device specific diagnosis information is transferred in addition to the Profile diagnosis.

Cyclic layout:

Slot	Description	Function Block types	Default unit
1	Volume Flow	AI-FB	m ³ /h
2	Velocity of Sound	AI-FB	m/s
3	Volume total	Totaliser-FB	m ³
4	Volume total	Totaliser-FB	m ³
5	Mass total	Totaliser-FB	kg
6	Mass Flow	AI-FB	kg/s
7	Flow speed	AI-FB	m/s
8	Gain	AI-FB	dB
9	SNR	AI-FB	dB

- AI: Analog Input
- FB: Function Block

There are separate settings to select the units for local display and PROFIBUS. Modifications of the units of the display will have no effect on the data transferred via PROFIBUS. A master class 2 tool is required to modify the units for PROFIBUS transfer.

Valid GSD Modules:

AI-FB	Empty Module AI: Out
Totaliser-FB	Empty Module TOT (Id.F.): Total TOT (Id.F.): SetTot + Total TOT (Id.F.): ModeTot + Total TOT (Id.F.): SetTot+ModeTot+Total TOT (Id.F.): SetTot TOT (Id.F.): ModeTot TOT (Id.F.): SetTot + ModeTot

GSD File required:

GSD file **KR014521.GSD** is required in this mode. This GSD file provides complete functionality of the PROFIBUS PA device. All function blocks are available for cyclic data transfer.



INFORMATION!

If another GSD file is used in the PROFIBUS master system the cyclic data transfer cannot be established in this setting.

**INFORMATION!**

During network configuration the user has to define which function block outputs of the signal converter should be transferred cyclically to the master. This is performed by a bus configuration tool (e.g. "HW- Config" for PC S7 from Siemens). This tool offers specific functions as follows:

1. It is possible to configure an "Empty block" (the code of an "Empty" block is defined as 0x00) on each block number. This implies: no data is transmitted in the cyclic data telegram for this block.
2. There is NO "Totaliser (TOT)" function block allowed on block position 1, 2, 6, 7, 8, 9! On these positions, only an "Analog Input (AI)" function block or an "Empty" block is allowed!
(Note: All codes supported by "Analog Input (AI)" – and "Totaliser (TOT)" – function blocks will be found in the corresponding GSD files.)
3. There is NO "Analog Input (AI)" function block allowed on block position 3, 4 and 5! On these positions, only a "Totaliser (TOT)" function block or an "Empty" block is allowed!
4. There is a choice of 7 different totaliser functions, which can be allocated to the blocks 3, 4 and/or 5.

Profile specific Ident. Number (9741 hex)

Functionality is reduced to the requirements which are mandatory in the PA Profile; e.g. 2 x AI-FB and 1 x TOT-FB are available for cyclic data transfer only. Device specific diagnosis information is not available via cyclic PROFIBUS services. Nevertheless this behaviour will improve interchangeability between devices of different vendors because only functions are available which are provided by all PROFIBUS PA ultrasonic flowmeters. Exchange is possible without modifying the configuration of the control system.

Cyclic layout:

Slot	Description	Function Block type	Default unit
1	Volume Flow	AI-FB	m ³ /h
2	Velocity of sound	AI-FB	m/s
3	Totaliser	Totaliser-FB	m ³

Valid GSD Modules:

AI-FB	EMPTY_MODULE AI
Totaliser-FB	EMPTY_MODULE TOTAL SETTOT_TOTAL SETTOT_MODETOT_TOTAL

GSD File required:

GSD file **PA139741.GSD** is required in this mode. This file is provided by PROFIBUS International. Take care that "Condensed Status and Diagnosis" is not supported by this file.

**INFORMATION!**

If another GSD file is used in the PROFIBUS master system the cyclic data transfer cannot be established in this setting.

3.8 Summary

The following table shows a summary of the supported combinations of the PROFIBUS device with MBP Physical Interface and PA Profile 3.02:

Ident. Number Selector	Ident. Number	GSD File	Status
Automatic adaptation mode	4521	KR014521.GSD	Classic / Condensed
	9741	PA139741.GSD ①	Classic
Manufacturer specific Ident. Number	4521	KR014521.GSD	Classic / Condensed
Profile specific Ident. Number	9741	PA139741.GSD ①	Classic

① This file is provided by PROFIBUS International (www.profibus.com). Take care that "Condensed Status and Diagnosis" is not supported by this file.

4.1 Configuration of cyclic data transfer

During network configuration the user has to select which function block input/output data shall be transferred between the PROFIBUS master and the PROFIBUS slave. Network configuration will be done using one of the GSD files described before. During configuration a functional module - describing a valid configuration of a single function block and defined in the GSD file selected - has to be assigned to each slot of the device in order to select which data has to be transferred for the corresponding function blocks.

The cyclic layout (have a look at chapter "Ident. Number selector") shows which type of functional module is valid for each slot.

The order of transmission of the data always remains the same. If an "Empty Module" is assigned to a slot no data will be sent for the corresponding function block and all function block data following this empty module will move up one position.

4.2 Cyclic data

In a PROFIBUS network cyclic data is described from the point of view of the master. Therefore input data is transferred from the slave to the master while output data is transferred from the master to the slave.

4.2.1 Input data

Input data is transferred from the PROFIBUS device to the master for the measuring value and the totalizer values. The format is the same for both. If input data transfer is configured 5 bytes are transferred for the corresponding slot:

- 4 byte float value (Float Format according to IEEE Standard 754 Short Real Number)
- 1 byte status value

Float value

The following example describes the format of the float value according to IEEE Standard 754 Short Real Number:

Float format

Byte n							Byte n+1								
Bit7	Bit6						Bit7	Bit6							
VZ	2^7	2^6	2^5	2^4	2^3	2^2	2^1	2^0	2^{-1}	2^{-2}	2^{-3}	2^{-4}	2^{-5}	2^{-6}	2^{-7}
Exponent							Mantissa								

Byte n+2							Byte n+3								
Bit7							Bit7								
2^{-8}	2^{-9}	2^{-10}	2^{-11}	2^{-12}	2^{-13}	2^{-14}	2^{-15}	2^{-16}	2^{-17}	2^{-18}	2^{-19}	2^{-20}	2^{-21}	2^{-22}	2^{-23}
Mantissa							Mantissa								

Example (binary): 40 F0 00 00 (hex) = 0100 0000 1111 0000 0000 0000 0000 0000

Formula:

$$\text{value} = (-1)^{VZ} * 2^{(\text{Exponent} - 127)} * (1 + \text{Mantissa})$$

$$\text{value} = (-1)^0 * 2^{(129 - 127)} * (1 + 2^{-1} + 2^{-2} + 2^{-3})$$

$$\text{value} = 1 * 4 * (1 + 0.5 + 0.25 + 0.125)$$

$$\text{value} = 7.5$$

Status value

The PROFIBUS device supports the PROFIBUS-PA Profile Version 3.02. In this Profile the Condensed Status and Diagnosis has replaced by default the Classic Status and Diagnosis of the PROFIBUS-PA Profile Version 3.0. The Condensed Status and Diagnosis has been created to make diagnostic events more obvious and to allow predictive and preventive maintenance. Nevertheless Classic Status and Diagnosis is still available for this device. It is implemented for backwards compatibility to "older" devices or PLC systems which do not support Condensed Status and Diagnosis.

The device may be switched between "Condensed Status and Diagnosis" and "Classic Status and Diagnosis"

- automatically during start-up of the cyclic data transfer by setting the parameter PRM_COND within the Set_Prm service data.
- using an engineering tool (e.g. DD/DTM) to write the parameter COND_STATUS_DIAG (slot 0, index 43).
- using the device display menu (menu item "Condensed Status", C5.8.8)

Coding for the first two parameters is:

- 0: Classic Status
- 1: Condensed Status (factory setting)

Coding for the third selection is:

- OFF: Classic Status
- ON: Condensed Status (factory setting)

**INFORMATION!**

The parameter COND_STATUS_DIAG cannot be modified directly if cyclic data transfer is active. Nevertheless it is reset to the factory setting if a reset to default data is requested by an engineering tool.

The coding of the status value depends on the active status and diagnosis mode. It is described in the following tables.

Condensed Status

The Condensed Status codes have been defined to allow easier decoding of the information provided by the PROFIBUS devices. The coding is shown in the following table:

Quality		Quality substatus				Limits		
Gr	Gr	QS	QS	QS	QS	Qu	Qu	
2^7	2^6	2^5	2^4	2^3	2^2	2^1	2^0	
0	0							= bad
0	1							= uncertain
1	0							= good (Non Cascade)
1	1							= good (Cascade) - not supported

Status = bad

Quality		Quality substatus				Limits		
Gr	Gr	QS	QS	QS	QS	Qu	Qu	
2^7	2^6	2^5	2^4	2^3	2^2	2^1	2^0	
0	0	0	0	0	0	0	0	= non-specific (not provided by the device)
0	0	1	0	0	0	1	1	= passivated (diagnostic alerts inhibited)
0	0	1	0	0	1	x	x	= maintenance alarm, more diagnosis available
0	0	1	0	1	0	x	x	= process related, no maintenance
0	0	1	1	1	1	x	x	= function check / local override; value not usable

Status = uncertain

Quality		Quality substatus				Limits		
Gr	Gr	QS	QS	QS	QS	Qu	Qu	
2^7	2^6	2^5	2^4	2^3	2^2	2^1	2^0	
0	1	0	0	1	0	x	x	= substitute set
0	1	0	0	1	1	1	1	= initial value
0	1	1	0	1	0	x	x	= maintenance demanded
0	1	1	1	0	0	1	1	= simulated value, start
0	1	1	1	0	1	1	1	= simulated value, end
0	1	1	1	1	0	x	x	= process related, no maintenance

Status = good (Non Cascade)

Quality		Quality substatus				Limits		
Gr	Gr	QS	QS	QS	QS	Qu	Qu	
2 ⁷	2 ⁶	2 ⁵	2 ⁴	2 ³	2 ²	2 ¹	2 ⁰	
1	0	0	0	0	0	x	x	= ok
1	0	0	0	0	1	x	x	= update event
1	0	0	0	1	0	x	x	= advisory alarm
1	0	0	0	1	1	x	x	= critical alarm
1	0	1	0	0	0	x	x	= initiate fail safe (not provided by signal converter)
1	0	1	0	0	1	x	x	= maintenance required
1	0	1	0	1	0	x	x	= maintenance demanded
1	0	1	1	1	1	x	x	= function check

Status = Limits

Quality		Quality substatus				Limits		
Gr	Gr	QS	QS	QS	QS	Qu	Qu	
2 ⁷	2 ⁶	2 ⁵	2 ⁴	2 ³	2 ²	2 ¹	2 ⁰	
						0	0	= ok
						0	1	= low limited
						1	0	= high limited
						1	1	= constant

Check the first two quality bits in order to get the quality information of the measurement value:

- **Good (Non Cascade):** function block output value is ok and can be used without restrictions
- **Good (Cascade):** will not be supported, because it is not applicable for the device
- **Uncertain:** function block output value can be used but the accuracy can not be guaranteed (e.g. function block outputs value has been frozen or A/D converter is saturated or out of range)
- **Bad:** function block output value is bad - don't use it for process control!

The "Quality-Substatus" and "Limit" bits will be used for further diagnostics or limit checking.

**INFORMATION!**

The status should be monitored because a number will be transmitted even if the status of the measurement value is bad or uncertain. This is the only way to check the quality of the transmitted measurement values.

Classic Status

The Classic Status is implemented to provide compatibility to systems which are not configured for Condensed Status. The coding is shown in the following table:

Quality		Quality substatus				Limits		
Gr	Gr	QS	QS	QS	QS	Qu	Qu	
2^7	2^6	2^5	2^4	2^3	2^2	2^1	2^0	
0	0							= bad
0	1							= uncertain
1	0							= good (Non Cascade)
1	1							= good (Cascade) - not supported

Status = bad

Quality		Quality substatus				Limits		
Gr	Gr	QS	QS	QS	QS	Qu	Qu	
2^7	2^6	2^5	2^4	2^3	2^2	2^1	2^0	
0	0	0	0	0	0			= non-specific
0	0	0	0	0	1			= configuration error
0	0	0	0	1	0			= not connected
0	0	0	0	1	1			= device failure
0	0	0	1	0	0			= sensor failure
0	0	0	1	0	1			= no communication (last usable value)
0	0	0	1	1	0			= no communication (no usable value)
0	0	0	1	1	1			= out of service

Status = uncertain

Quality		Quality substatus				Limits		
Gr	Gr	QS	QS	QS	QS	Qu	Qu	
2^7	2^6	2^5	2^4	2^3	2^2	2^1	2^0	
0	1	0	0	0	0			= non-specific
0	1	0	0	0	1			= last usable value
0	1	0	0	1	0			= substitute-set
0	1	0	0	1	1			= initial value
0	1	0	1	0	0			= sensor conversion not accurate
0	1	0	1	0	1			= engineering unit violation (unit not in the valid set)
0	1	0	1	1	0			= sub-normal
0	1	0	1	1	1			= configuration error
0	1	1	0	0	0			= simulated value

Status = good (Non Cascade)

Quality		Quality substatus				Limits		
Gr	Gr	QS	QS	QS	QS	Qu	Qu	
2 ⁷	2 ⁶	2 ⁵	2 ⁴	2 ³	2 ²	2 ¹	2 ⁰	
1	0	0	0	0	0			= ok
1	0	0	0	0	1			= update event
1	0	0	0	1	0			= active advisory alarm
1	0	0	0	1	1			= active critical alarm
1	0	0	1	0	0			= unacknowledged update event
1	0	0	1	0	1			= unacknowledged advisory alarm
1	0	0	1	1	0			= unacknowledged critical alarm
1	0	1	0	0	0			= initiate fail safe
1	0	1	0	0	1			= maintenance required

Status = Limits

Quality		Quality substatus				Limits		
Gr	Gr	QS	QS	QS	QS	Qu	Qu	
2 ⁷	2 ⁶	2 ⁵	2 ⁴	2 ³	2 ²	2 ¹	2 ⁰	
						0	0	= ok
						0	1	= low limited
						1	0	= high limited
						1	1	= constant

Check the first two quality bits in order to get the quality information of the measurement value:

- **Good (Non Cascade):** function block output value is ok and can be used without restrictions
- **Good (Cascade):** will not be supported, because it is not applicable for the device
- **Uncertain:** function block output value can be used but the accuracy can not be guaranteed (e.g. function block outputs value has been frozen or A/D converter is saturated or out of range)
- **Bad:** function block output value is bad - don't use it for process control!

The "Quality-Substatus" and "Limit" bits will be used for further diagnostics or limit checking.

**INFORMATION!**

The status should be monitored because a number will be transmitted even if the status of the measurement value is bad or uncertain. This is the only way to check the quality of the transmitted measurement values.

4.2.2 Output data

Output data is transferred from the master to the PROFIBUS device to control the totalizers. Behaviour and coding is described by the following tables.

Module types (defined in GSD):

Total	cyclic transfer of the totalizer value with status to the master (no output data)
SetTot + Total	cyclic transfer of the totalizer value with status to the master + cyclic control data from master to the slave via the parameter SetTot
ModeTot + Total	cyclic transfer of the totalizer value with status to the master + cyclic control data from master to the slave via the parameter ModeTot
SetTot + ModeTot + Total	cyclic transfer of the totalizer value with status to the master + cyclic control data from master to the slave via the parameters SetTot and ModeTot (in this order)
SetTot	cyclic control data from master to the slave via the parameter SetTot
ModeTot	cyclic control data from master to the slave via the parameter ModeTot
SetTot + ModeTot	cyclic control data from master to the slave via the parameters SetTot and ModeTot (in this order)

Coding of SetTot

SetTot = 0	Totalizer is totalizing
SetTot = 1	Totalizer is reset to 0.0 and remains at this value until SetTot is reset to 0. If the value of SetTot changes from "1" to "0" the totalizer starts counting from 0.0.
SetTot = 2	Totalizer is set to the value defined by PresetTot. PresetTot can be written via an acyclic service (totalizer in slot 3: Slot 3, Index 32; totalizer in slot 4: Slot 4, Index 32; totalizer in slot 5: Slot 5, Index 32). If the value of SetTot changes from "2" to "0" the totalizer starts counting from the current value defined by PresetTot.
Other values are not accepted for SetTot. Values are ignored; totalizer remains in its last valid setting.	

Coding of ModeTot

ModeTot = 0	True arithmetic integration of the incoming rate values.
ModeTot = 1	Totalization of positive incoming rate values only.
ModeTot = 2	Totalization of negative incoming rate values only.
ModeTot = 3	Totalizer is stopped, no totalization is done.
ModeTot = 248	All incoming rates will be handled as positive values; i.e. negative input values will be multiplied with "-1.0".
ModeTot = 249	All incoming rates will be handled as negative values; i.e. positive input values will be multiplied with "-1.0".
Other values are not accepted for ModeTot. Values are ignored; totalizer remains in its last valid setting.	



INFORMATION!

Take care that SetTot and ModeTot are level sensitive parameters; e.g. if SetTot is changed from "0" to "1" the totalizer is reset and stopped. It will not start counting before SetTot is reset to "0" via the control system or an engineering tool. It is not reset by the PROFIBUS device.

4.3 Diagnosis

The PROFIBUS device performs internal self-tests. The results are provided as detailed diagnosis information according to PA Profile 3.02. This diagnosis information is available via several parameters and can be read by an engineering tool (e.g. DD/DTM). In addition the diagnosis information is transferred via cyclic services towards the control system (e.g. PLC).

Diagnosis is bitwise coded. Therefore it is possible to report more than one indication simultaneously. The GSD file contains a text for each diagnosis bit in order to provide a text message in the control system. The references are defined by the UNIT_DIAG_BIT(i) entries. They show which bit is set to indicate a special diagnosis event.

The amount and content of the diagnosis information depends on the device configuration. The active Ident. Number and the selected status and diagnosis mode will influence diagnosis propagation. The following tables show the diagnosis events which are reported for different settings. The bit number is equal to the counting within the GSD file. It represents the position in the device-related diagnostic field of the Slave_Diag service.

Bit Number	supported	Description	Remedy
16	yes	Error appears	-
17	yes	Error disappears	-
24	①	Hardware failure electronics	The device or measurement is defective and cannot measure. Related output values are invalid. Typically a repair or replacement of the device is required. Check detailed diagnosis. Restart the device. If the error occurs again: send the device back to the manufacturer with an indication of the error.
29	①	Measurement failure	The device or application condition is in a way that the measurement accuracy may be reduced. But still the measurement value follows the source. E.g. the device may be operated outside its specified operating range. Check detailed diagnosis. Restart the device. If the error occurs again: send the device back to the manufacturer with an indication of the error.
35	yes	Restart	Device is restarted because of power-up or warmstart request. In case of unexpected restart: send the device back to the manufacturer with an indication of the error.
36	yes	Coldstart	Device is reset to its Factory/Default settings because of a user request. Recover user specific parameter settings.
37	yes	Maintenance required	The device detects problem(s), which are less severe compared to the diagnosis "Measurement failure". But still the measurement values are accurate. The output values are still valid, but this may change in the near future. Check detailed diagnosis to solve the problem.
39	yes	Ident_Number violation	Ident. Number Selector was modified while cyclic data transfer was active. To clear this message perform one of the following actions: <ul style="list-style-type: none"> • Reset Ident. Number Selector to its former setting • Stop cyclic data transfer • Restart the device

Bit Number	supported	Description	Remedy
40	②	Maintenance alarm	The device or measurement is defective and cannot measure. Related output values are invalid. Typically a repair or replacement of the device is required. Check detailed diagnosis. Restart the device. If the error occurs again: send the device back to the manufacturer with an indication of the error.
41	②	Maintenance demanded	The device or application condition is in a way that the measurement accuracy may be reduced. But still the measurement value follows the source. E.g. the device may be operated outside its specified operating range. Check detailed diagnosis. Restart the device. If the error occurs again: send the device back to the manufacturer with an indication of the error.
42	②	Function check	Simulation is active. Disable simulation to clear this message.
55	yes	Extension available	Refer to detailed diagnosis in bits 56 to 103.
56	③	C – Process (classification fixed - not changeable)	Process related "Function check" running. E.g. the measurement values may be simulated values for a currently performed check. The related output values are temporarily invalid. Turn off "Function check" to change back into measurement mode / ⑥.
57	③	C – Configuration (classification fixed - not changeable)	Configuration related "Function check" running. E.g. the measurement values may be simulated values for a currently performed check. The related output values are temporarily invalid. Turn off "Function check" to change back into measurement mode / ⑥.
58	③	C – Electronics (classification fixed - not changeable)	Converter Electronics related "Function check" running. E.g. the measurement values may be simulated values for a currently performed check. The related output values are temporarily invalid. Turn off "Function check" to change back into measurement mode / ⑥.
59	③	C – Sensor (classification fixed - not changeable)	Sensor related "Function check" running. E.g. the measurement values may be simulated values for a currently performed check. The related output values are temporarily invalid. Turn off "Function check" to change back into measurement mode / ⑥.
60	③	F – Process (classification fixed - not changeable)	Process related settings are defective. Related output values are invalid. A repair or replacement of the device can be necessary. Check process parameters / ④ - restart the device – if the error still occur contact the service department of the manufacturer.
61	③	F – Configuration (classification fixed - not changeable)	Configuration is defective. Related output values are invalid. A repair or replacement of the device can be necessary. Check configuration / ④ - restart the device – if the error still occur contact the service department of the manufacturer.
62	③	F – Electronics (classification fixed - not changeable)	Converter Electronic is defective and not able to measure. Related output values are invalid. Typically a repair or replacement of the device is required. Check converter / ④ - restart the device – if the error still occur send back the device to the manufacturer with an indication of the error.
63	③	F – Sensor (classification fixed - not changeable)	Sensor is defective and not able to measure. Related output values are invalid. Typically a repair or replacement of the device is required. Check sensor / cabling / ④ - restart the device – if the error still occur send back the device to the manufacturer with an indication of the error.
64	③	M – Process (classification fixed - not changeable)	Process related problem(s) detected. But still the measurement values are accurate. The output values are still valid, but this may change in the near future. Check problem(s) / ⑤ - if the problem(s) cannot be fixed contact the service department of the manufacturer with an indication of the problem(s).

Bit Number	supported	Description	Remedy
65	③	M – Configuration (classification fixed - not changeable)	Configuration related problem(s) detected. But still the measurement values are accurate. The output values are still valid, but this may change in the near future. Check problem(s) / ⑤ - if the problem(s) cannot be fixed contact the service department of the manufacturer with an indication of the problem(s).
66	③	M – Electronics (classification fixed - not changeable)	Converter Electronic related problem(s) detected. But still the measurement values are accurate. The output values are still valid, but this may change in the near future. Check problem(s) / ⑤ - if the problem(s) cannot be fixed contact the service department of the manufacturer with an indication of the problem(s).
67	③	M – Sensor (classification fixed - not changeable)	Sensor related problem(s) detected. But still the measurement values are accurate. The output values are still valid, but this may change in the near future. Check problem(s) / ⑤ - if the problem(s) cannot be fixed contact the service department of the manufacturer with an indication of the problem(s).
68	③	S – Process (classification fixed - not changeable)	Process related fault(s) detected. E.g. the device may be operated outside its specified operating range. The measurement accuracy may be reduced. But still the measurement value follows the source. Check fault(s) detected / ④ - if the fault(s) cannot be cleared contact the service department of the manufacturer with an indication of the problem(s).
69	③	S – Configuration (classification fixed - not changeable)	Configuration related fault(s) detected. E.g. the device may be operated outside its specified operating range. The measurement accuracy may be reduced. But still the measurement value follows the source. Check fault(s) detected / ④ - if the fault(s) cannot be cleared contact the service department of the manufacturer with an indication of the problem(s).
70	③	S – Electronics (classification fixed - not changeable)	Converter Electronic related fault(s) detected. E.g. the device may be operated outside its specified operating range. The measurement accuracy may be reduced. But still the measurement value follows the source. Check fault(s) detected / ④ - if the fault(s) cannot be cleared contact the service department of the manufacturer with an indication of the problem(s).
71	③	S – Sensor (classification fixed - not changeable)	Sensor related fault(s) detected. E.g. the device may be operated outside its specified operating range. The measurement accuracy may be reduced. But still the measurement value follows the source. Check fault(s) detected / ④ - if the fault(s) cannot be cleared contact the service department of the manufacturer with an indication of the problem(s).
72	③	["I-"] Electr: Power Failure (default classification / ⑨)	Information only; e.g. power-down detected / ⑦. Just information. No impact on measurement expected.
74	③	["S-"] Config_ Totalizer (default classification / ⑨)	Configuration related fault(s) detected concerning totalizer. E.g. "Overflow" of a totalizer – counting starts with "zero". The measurement accuracy may be reduced. But still the measurement value follows the source. Check fault(s) detected / ④ - if the fault(s) cannot be cleared contact the service department of the manufacturer with an indication of the problem(s).
75	③	["S-"] Proc: Signal unreliable (default classification / ⑨)	Process related fault(s) detected concerning the "sensor". E.g. not reached accuracy. The measurement accuracy may be reduced. But still the measurement value follows the source. Check fault(s) detected / ④ - if the fault(s) cannot be cleared contact the service department of the manufacturer with an indication of the problem(s).

Bit Number	supported	Description	Remedy
76	③	["S-"] Proc: Signal lost (default classification / ⑨)	Process related fault(s) detected concerning the "sensor". E.g. an unknown accuracy. The measurement accuracy may be reduced. But still the measurement value follows the source. Check fault(s) detected / ④ - if the fault(s) cannot be cleared contact the service department of the manufacturer with an indication of the problem(s).
77	③	["S-"] Proc: Empty Pipe (default classification / ⑨)	Process related error(s) detected concerning the "sensor". E.g. no liquid present. Related output values are invalid. A repair or replacement of the device can be necessary. Check error(s) detected / ④ - restart the device – if the error still occur contact the service department of the manufacturer.
78	③	["S-"] Electr: IO Connection (default classification / ⑨)	Converter related fault(s) detected concerning interconnection of modules and terminals. E.g. an open or short circuit at the related terminal. The measurement accuracy may be reduced. But still the measurement value follows the source. Check fault(s) detected / ④ - if the fault(s) cannot be cleared contact the service department of the manufacturer with an indication of the problem(s).
81	③	["I-"] Electr: Info. Operation (classification fixed - not changeable)	Converter Electronic related information. Just information. No impact on measurement expected. Check information just present / ⑦.
82	③	["I-"] Config: No Meas. Value (classification fixed - not changeable)	Configuration / measurement value related information. Just information. No impact on measurement expected. Check information just present / ⑦.
99	③	F - No Meas. Value (classification fixed - not changeable)	Measurement value not available (or no more available) / ⑧. (status bit "F – Electronics" will be set too)
100	③	F - Parameter Update Error (classification fixed - not changeable)	Error occurred during parameter update of PROFIBUS parameters / ⑧. (status bit "F – Configuration" will be set too)
101	③	F - No Device Communication (classification fixed - not changeable)	No communication between basic device and PROFIBUS module / ⑧. (status bit "F – Electronics" will be set too)

- ① Indication is supported if Classic Diagnosis is active only.
 - ② Indication is supported if Condensed Diagnosis is active only.
 - ③ Indication is supported in cyclic diagnosis only if Ident. Number 4520 or 4521 hex is active. Nevertheless this information is always available via acyclic access (e.g. by using DD / DTM) for all Ident. Numbers supported.
- yes Indication is supported for all Ident. Numbers.
- ④ If available readout more detailed diagnosis information using the device display ("Test → Information → Status Details → ..." / menu B3.2) or the PROFIBUS parameter "Device Status Complete (Slot 0, Index 167)" via "DD"/ "DTM" and try to clear faults displayed.
 - ⑤ If available readout more detailed diagnosis information using the device display ("Test → Information → Status Details → ..." / menu B3.2) or the PROFIBUS parameter "Device Status Complete (Slot 0, Index 167)" via "DD"/ "DTM" and try to fix the problem(s) occurred.
 - ⑥ If available readout more detailed diagnosis information using the device display ("Test → Information → Status Details → ..." / menu B3.2) or the PROFIBUS parameter "Device Status Complete (Slot 0, Index 167)" via "DD"/ "DTM" and checkout which sort of "Function check" is running.
 - ⑦ If available readout more detailed diagnosis information using the device display ("Test → Information → Status Details → ..." / menu B3.2) or the PROFIBUS parameter "Device Status Complete (Slot 0, Index 167)" via "DD"/ "DTM" to get a more detailed overview about all additional information just present
 - ⑧ Detailed information of the PROFIBUS module itself – no more detailed information available.
 - ⑨ Classification is changeable by the user itself – have a look at chapter "Variable Event Groups".



INFORMATION!

A rough classification of status values according "NE107" is done by using the first character of the description of a status event:

- *F- / ("F-"): Failure (No measurement possible)*
- *S- / ("S-"): Out of specification (Measurements are available but no longer sufficiently accurate and should be checked)*
- *M- / ("M-"): Maintenance required: (Measurements are still accurate but this could change soon)*
- *C- / ("C-"): Function check: (A test function is active; the displayed or transferred measured value does not correspond to the actual measured value)*
- *I- / ("I-"): Information (not defined by NE107 / device specific): (No direct influence on the measurements)*



INFORMATION!

Each diagnosis event defined by UNIT_DIAG_BIT (56) up to UNIT_DIAG_BIT (82) (being contained in PROFIBUS parameter "DIAGNOSIS_EXTENSION") will be defined as a so called "Event group" (for detailed information refer to chapter 6.6 "Status messages and diagnostic information" of the UFC 400 Handbook). Each "Event group" will consist of up to 32 so called "Single events". The diagnosis event bit of an "Event group" will be set if at least one "Single event" belonging to this "Event group" will occur. "Single events" occurred can be displayed by using the UFC 400 display menu and/or by using the UFC 400 PROFIBUS DTM or the UFC 400 PROFIBUS EDD in conjunction with the appropriate control software (UFC 400 PROFIBUS DTM in conjunction with PACTware; the UFC 400 PROFIBUS EDD in conjunction with SIMATIC PDM). An overview of all "Single events" supported by UFC 400 can be found in the UFC 400 Handbook.

Displaying "Single events" currently existing using the UFC 400 PROFIBUS DTM:

Enter Menu "Device → Diagnosis → Current status messages" to get a detailed view of all "Event groups" with at least one "Single event" currently existing:

- Have a look at section "Current status display (click for details)"
- All "Event groups" with at least one "Single event" currently existing will be displayed
- A "double-click" on an "Event group" displayed will display all "Single events" (belonging to this "Event group") currently existing.

Note: A "single-click" on both an "Event group" or an "Single event" will display additional information within section "Detailed information for selected status"

Displaying "Single events" currently existing using the UFC 400 PROFIBUS EDD:

Enter Menu "Diagnostics → Device status" to get a view of all "Event groups" with at least one "Single event" currently existing:

- Have a look at section "Diagnosis (extension 1)"
- All "Event groups" with at least one "Single event" currently existing will be marked (see check box in front of the name of the "Event group")

Set "Diagnosis details" to "Show action only" or "Show all".

- Have a look at section "Diagnosis details"
- All "Event groups" with at least one "Single event" currently existing will be displayed
- All "Single events" (belonging to a "Event group" displayed) currently existing will be marked (see check box in front of the name of the "Single event")

Displaying "Single events" currently existing using the UFC 400 display menu:

Enter Menu "Test → Information → Status Details" (B3.2):

- All "Event groups" with at least one "Single event" currently existing will be displayed.
- Choose the "Event group" you are interested in.
- All "Single events" (belonging to this "Event group") currently existing will be displayed.

4.3.1 Mapping of DIAGNOSIS_EXTENSION bits into DIAGNOSIS bits if "Condensed Status and Diagnosis" handling selected

DIAGNOSIS_EXTENSION (Condensed)			DIAGNOSIS (Condensed)										
			1		2				3			4	
			0	5	3	4	5	7	0	1	2	7	
Octet number	Bit number	Subparameter	DIA_HW_ELECTR Hardware failure electronics (24)	DIA_MEASUREMENT Measurement failure (29)	DIA_WARMSTART Restart (35)	DIA_COLDSTART Coldstart (36)	DIA_MAINTENANCE Maintenance required (37)	IDENT_NUMBER_Violation Ident_Number violation (39)	DIA_MAINTENANCE_ALARM Maintenance alarm (40)	DIA_MAINTENANCE_DEMANDED Maintenance demanded (41)	DIA_FUNCTION_CHECK Function check (42)	EXTENSION_AVAILABLE Extension available (55)	
1	7	F_SENSOR (63)							1			X	
	6	F_ELECTRONICS (62)							1			X	
	5	F_CONFIGURATION (61)							1			X	
	4	F_PROCESS (60)							1			X	
	3	C_SENSOR (59)									X	X	
	2	C_ELECTRONICS (58)									X	X	
	1	C_CONFIGURATION (57)									X	X	
	0	C_PROCESS (56)									X	X	
2	7	S_SENSOR (71)								X		X	
	6	S_ELECTRONICS (70)								X		X	
	5	S_CONFIGURATION (69)								X		X	
	4	S_PROCESS (68)								X		X	
	3	M_SENSOR (67)					X					X	
	2	M_ELECTRONICS (66)					X					X	
	1	M_CONFIGURATION (65)					X					X	
	0	M_PROCESS (64)					X					X	
3	7	F_PROC_CURRENT_INPUT (79)							1			X	
	6	S_ELECTR_IO_CONNECTION (78)								X		X	
	5	S_PROC_EMPTY_PIPE (77)								X		X	
	4	S_PROC_SIGNAL_LOST (76)								X		X	
	3	S_PROC_SIGNAL_UNRELIABLE (75)								X		X	
	2	S_CONFIG_TOTALISER (74)								X		X	
		...										X	
	0	I_ELECTR_POWER_FAILURE (72)										X	

DIAGNOSIS_EXTENSION (Condensed)			DIAGNOSIS (Condensed)									
			1		2				3			4
			0	5	3	4	5	7	0	1	2	7
Octet number	Bit number	Subparameter	DIA_HW_ELECTR Hardware failure electronics (24)	DIA_MEASUREMENT Measurement failure (29)	DIA_WARMSTART Restart (35)	DIA_COLDSTART Coldstart (36)	DIA_MAINTENANCE Maintenance required (37)	IDENT_NUMBER_Violation Ident_Number violation (39)	DIA_MAINTENANCE_ALARM Maintenance alarm (40)	DIA_MAINTENANCE_DEMANDED Maintenance demanded (41)	DIA_FUNCTION_CHECK Function check (42)	EXTENSION_AVAILABLE Extension available (55)
4	...											X
	2	I_CONFIG_NO_MEAS_VALUE (82)										X
	1	I_ELECTR_OPERATION_INFO (81)										X
	...											X
5	...											X
6	...											X
	5	F_NO_BASIC_DEVICE_COM (101)							1			X
	4	F_PARA_UPDATE_ERROR (100)							1			X
	3	F_MEAS_AVAILABLE_NO (99)							1			X
	...											X

1 :Corresponding DIAGNOSIS bit is set to 1 if status occurred **AND** Ext_Diag (Bit 3 of Station_status_1) will be set additionally

X :Corresponding DIAGNOSIS bit is set to 1 if status occurred

Value in () is equal the Bit Number of UNIT_DIAG_BIT() of the GSD file belonging to the Ident. Number selected

How to read the mapping table above:

- If e.g. the diagnosis event bit of "Event group" ("I-") **Electr: Info. Operation** (81) has been set the diagnosis event bit "**Extension available**" (55) will be set additionally.
- If e.g. the diagnosis event bit of "Event group" "**C – Sensor**" (59) has been set both the diagnosis event bit "**Extension available**" (55) and the diagnosis event bit "**Function check**" (42) will be set additionally.
- If e.g. the diagnosis event bit of "Event group" "**M – Sensor**" (67) has been set both the diagnosis event bit "**Extension available**" (55) and the diagnosis event bit "**Maintenance required**" (37) will be set additionally.
- If e.g. the diagnosis event bit of "Event group" "**S – Sensor**" (71) has been set both the diagnosis event bit "**Extension available**" (55) and the diagnosis event bit "**Maintenance demanded**" (41) will be set additionally.
- If e.g. the diagnosis event bit of "Event group" "**F – Sensor**" (63) has been set both the diagnosis event bit "**Extension available**" (55) and the diagnosis event bit "**Maintenance alarm**" (40) will be set additionally.

4.3.2 Mapping of DIAGNOSIS_EXTENSION bits into DIAGNOSIS bits if "Classic Status and Diagnosis" handling selected

DIAGNOSIS_EXTENSION (Classic)			DIAGNOSIS (Classic)										
			1		2				3			4	
			0	5	3	4	5	7	0	1	2	7	
Octet number	Bit number	Subparameter	DIA_HW_ELECTR Hardware failure electronics (24)	DIA_MEASUREMENT Measurement failure (29)	DIA_WARMSTART Restart (35)	DIA_COLDSTART Coldstart (36)	DIA_MAINTENANCE Maintenance required (37)	IDENT_NUMBER_Violation Ident_Number violation (39)	DIA_MAINTENANCE_ALARM Maintenance alarm (40)	DIA_MAINTENANCE_DEMANDED Maintenance demanded (41)	DIA_FUNCTION_CHECK Function check (42)	EXTENSION_AVAILABLE Extension available (55)	
1	7	F_SENSOR (63)	1									X	
	6	F_ELECTRONICS (62)	1									X	
	5	F_CONFIGURATION (61)	1									X	
	4	F_PROCESS (60)	1									X	
	3	C_SENSOR (59)										X	
	2	C_ELECTRONICS (58)										X	
	1	C_CONFIGURATION (57)										X	
	0	C_PROCESS (56)										X	
2	7	S_SENSOR (71)		X								X	
	6	S_ELECTRONICS (70)		X								X	
	5	S_CONFIGURATION (69)		X								X	
	4	S_PROCESS (68)		X								X	
	3	M_SENSOR (67)					X					X	
	2	M_ELECTRONICS (66)					X					X	
	1	M_CONFIGURATION (65)					X					X	
	0	M_PROCESS (64)					X					X	
3	7	F_PROC_CURRENT_INPUT (79)	1									X	
	6	S_ELECTR_IO_CONNECTION (78)		X								X	
	5	S_PROC_EMPTY_PIPE (77)		X								X	
	4	S_PROC_SIGNAL_LOST (76)		X								X	
	3	S_PROC_SIGNAL_UNRELIABLE (75)		X								X	
	2	S_CONFIG_TOTALISER (74)		X								X	
		...										X	
	0	I_ELECTR_POWER_FAILURE (72)										X	

DIAGNOSIS_EXTENSION (Classic)			DIAGNOSIS (Classic)										
			1		2				3			4	
			0	5	3	4	5	7	0	1	2	7	
Octet number	Bit number	Subparameter	DIA_HW_ELECTR Hardware failure electronics (24)	DIA_MEASUREMENT Measurement failure (29)	DIA_WARMSTART Restart (35)	DIA_COLDSTART Coldstart (36)	DIA_MAINTENANCE Maintenance required (37)	IDENT_NUMBER_Violation Ident_Number violation (39)	DIA_MAINTENANCE_ALARM Maintenance alarm (40)	DIA_MAINTENANCE_DEMANDED Maintenance demanded (41)	DIA_FUNCTION_CHECK Function check (42)	EXTENSION_AVAILABLE Extension available (55)	
4	...											X	
	2	I_CONFIG_NO_MEAS_VALUE (82)										X	
	1	I_ELECTR_OPERATION_INFO (81)										X	
	...											X	
5	...											X	
6	...											X	
	5	F_NO_BASIC_DEVICE_COM (101)										X	
	4	F_PARA_UPDATE_ERROR (100)										X	
	3	F_MEAS_AVAILABLE_NO (99)										X	
	...											X	

1 :Corresponding DIAGNOSIS bit is set to 1 if status occurred **AND** Ext_Diag (Bit 3 of Station_status_1) will be set additionally

X :Corresponding DIAGNOSIS bit is set to 1 if status occurred

Value in () is equal the Bit Number of UNIT_DIAG_BIT() of the GSD file belonging to the Ident. Number selected

How to read the mapping table above:

- If e.g. the diagnosis event bit of "Event group" ("I-") **Electr: Info. Operation** (81) has been set the diagnosis event bit "**Extension available**" (55) will be set additionally.
- If e.g. the diagnosis event bit of "Event group" "**C – Sensor**" (59) has been set both the diagnosis event bit "**Extension available**" (55) and the diagnosis event bit "Function check" (42) will be set additionally.
- If e.g. the diagnosis event bit of "Event group" "**M – Sensor**" (67) has been set both the diagnosis event bit "**Extension available**" (55) and the diagnosis event bit "**Maintenance required**" (37) will be set additionally.
- If e.g. the diagnosis event bit of "Event group" "**S – Sensor**" (71) has been set both the diagnosis event bit "**Extension available**" (55) and the diagnosis event bit "**Measurement failure**" (29) will be set additionally.
- If e.g. the diagnosis event bit of "Event group" "**F – Sensor**" (63) has been set both the diagnosis event bit "**Extension available**" (55) and the diagnosis event bit "**Hardware failure electronics**" (24) will be set additionally.

4.3.3 Variable "Event groups"

As already mentioned in the UFC 400 Handbook there are 7 "Event groups" available with a variable classification ("F", "S", "M", "C" or "I"):

- ("I-") Electr: Power Failure
- ("S-") Config_ Totalizer
- ("S-") Proc: Signal Unreliable
- ("S-") Proc: Signal Lost
- ("S-") Proc: Empty Pipe
- ("S-") Electr: IO Connection
- ("F-") Proc: Current Input



CAUTION!

*It is **recommended** to use the **default** classification. If the default classification of a variable "Event Group" should be changed please note:*

If using the **DTM** or **EDD** you are able to choose one of the following settings:

DTM: Enter menu: → "Parameters → Input → Diagnostics":

EDD: Enter menu: → Online menu: "Device → Setup → Device → Diagnosis mapping and filter":
or
→ Offline menu: "<TAG> → Offline → Setup → Device → Diagnosis mapping and filter":

if condensed status and diagnosis handling selected:

"F"	Failure	diagnosis: DIA_MAINTENANCE_ALARM (Maintenance alarm (40))
		status: BAD - maintenance alarm
"S"	Out of specification	diagnosis: DIA_MAINTENANCE_DEMAND (Maintenance demanded (41))
		status: UNCERTAIN - process related, no maintenance
"M"	Maintenance required	diagnosis: DIA_MAINTENANCE (Maintenance required (37))
		status: GOOD - maintenance demanded
"C"	Function check	diagnosis: DIA_FUNCTION_CHECK (Function check (42))
		status: GOOD - function check
"I"	Information	diagnosis: NO DIAGNOSIS EVENTS (no diagnosis events) ①
		status: GOOD - ok

① Bit "EXTENSION_AVAILABLE" of parameter DIAGNOSIS will be set if at least one Bit of parameter "DIAGNOSIS_EXTENSION" has been set.

Above mentioned definitions for both diagnosis and status will be internally used for PROFIBUS diagnosis and status handling of the classifications stated above which will be possible for the variable "Event groups".

if classic status and diagnosis handling selected:

"F"	Failure	diagnosis: DIA_HW_ELECTR (Hardware failure electronics (24))
		status: BAD - Device Failure
"S"	Out of specification	diagnosis: DIA_MEASUREMENT (Measurement failure (29))
		status: UNCERTAIN - sensor conver. not accur.
"M"	Maintenance required	diagnosis: DIA_MAINTENANCE (Maintenance required (37))
		status: GOOD (NC) - maintenance required
"C"	Function check	diagnosis: NO DIAGNOSIS EVENTS (Status OK – function check only)
		status: UNCERTAIN - simulated value (Function Check)
"I"	Information	diagnosis: NO DIAGNOSIS EVENTS (no diagnosis events) ①
		status: GOOD - ok

① Bit "EXTENSION_AVAILABLE" of parameter DIAGNOSIS will be set if at least one Bit of parameter "DIAGNOSIS_EXTENSION" has been set.

Above mentioned definitions for both diagnosis and status will be internally used for PROFIBUS diagnosis and status handling of the classifications stated above which will be possible for the variable "Event groups".

If using the **Display Menu** of the UFC 400 please have a look at the general description of menu section C1.10.3 to C1.10.8 located at the end of this documentation.

**CAUTION!**

Only the classification of an above mentioned "Event groups" will be changeable – changing the classification of a "Single event" is not possible at all!!

4.3.4 Filtering of "Single events"

As already mentioned before each "Event group" can consist of up to 32 "Single events". In some special cases a "Single event" should not be taken into consideration. Using "filtering" this "Single event" can be disabled – that means: if this "Single event" will occur the diagnosis event bit of the "Event group" associated with this "Single event" will not be set.



CAUTION!

"Single events" of variable "Event groups" can only be disabled. It is strongly recommended to use the default setting. If filtering is used please be aware of the fact that the "Single event" concerned (deactivated by filtering) neither will be taken into consideration during calculation of both the device status and the status of measurement values nor will be displayed as information.

Filtering of "Single events" will only be possible if using the UFC 400 PROFIBUS DTM (in conjunction with PACTware) or the UFC 400 PROFIBUS EDD (in conjunction with SIMATIC PDM). Filtering of "Single events" will not be possible if using the UFC 400 display menu.

Filtering of "Single events" using the UFC 400 PROFIBUS DTM:

Enter Menu "Parameters → Input → Diagnostics":

- "Open" "Event group" required by "single click" on "+" in front of the name of the "Event group".
- All "Single Events" belonging to this group will be displayed.
- Unmark all check boxes of "Single events" to be filtered.
- Transfer new filter setting(s) to the PROFIBUS device.

Filtering of "Single events" using the UFC 400 PROFIBUS EDD:

Enter menu: → **Online menu:** "Device → Setup → Device → Diagnosis mapping and filter → Diagnosis filter":

- Within the "Diagnosis filter" area all "Single Events" will be displayed which might be filtered.
- Unmark all check boxes of "Single Events" that shall be ignored.
- Transfer new filter setting(s) to the PROFIBUS device.

Enter menu: → **Offline menu:** "<TAG> → Offline → Setup → Device → Diagnosis mapping and filter → Diagnosis filter":

- All "Single Events" will be displayed which might be filtered.
- Unmark all check boxes of "Single Events" that shall be ignored.
- Transfer new filter setting(s) to the PROFIBUS device.

Detailed description of special settings concerning the PROFIBUS features easily operated via the local display menu of the signal converter (refer to the following sections). For a detailed description of the menus and functions in general please refer to the standard product documentation of the signal converter.

5.1 Menu A, Quick Setup

No.	Function	Setting / Description
-----	----------	-----------------------

A2 Tag

A2	Tag	Tag descriptor of the physical block of the PROFIBUS module will be displayed. The Tag descriptor provides an application specific reference to the blocks. It will be assigned by the user of the device. The Tag descriptor is an octet string (a visible string will be preferred) consisting of 32 byte. The first 21 characters will be displayed only!
----	-----	--

A3 Reset

A3	Reset	
A3.1	Reset Errors	Reset Errors? Select: no/yes
The following reset menus for the Totalisers are available only if the "quick access" has been activated in the menu "Setup → Device → Quick Setup (C5.9.x)". Each Totaliser can be activated independently for quick access.		
A3.2	FB3 Totaliser 1	Reset Totaliser 1 only? Select: No / Yes (available if activated in C5.9.1)
A3.3	FB4 Totaliser 2	Reset Totaliser 2 only? Select: No / Yes (available if activated in C5.9.2)
A3.4	FB5 Totaliser 3	Reset Totaliser 3 only? Select: No / Yes (available if activated in C5.9.3)

A4 Station Address

A4	Station Address	Selects the address of the device at the PROFIBUS interface. The PROFIBUS address can also be changed using the PROFIBUS service "set_slave_add". The input range is 0...125 according to the PROFIBUS specification. Address 126 is the default address and cannot be set via the PROFIBUS service "set_slave_add" - use menu instead to reset to default address.
----	-----------------	--

5.2 Menu B, Test

No.	Function	Settings / descriptions
-----	----------	-------------------------

B3 Information

B3.7	PROFIBUS	Available if there is a PROFIBUS interface in existence; the below mentioned information will be displayed about the PROFIBUS interface: <ul style="list-style-type: none"> • Hardware Revision of the PROFIBUS interface used • Software Version of the PROFIBUS interface used • Date of Compilation
------	----------	---

5.3 Menu C, Setup

No.	Function	Settings / descriptions
-----	----------	-------------------------

C1 Process Input

C1.10	Diagnostics	-
It is strongly recommended to use the default classification of the variable "Event groups" mentioned below. If the default classification should be changed please note! ①		
C1.10.5	Proc: Signal Unreliable	Select:Out of Specification (default)FailureInformationMaintenance RequiredFunction Check ①
C1.10.3	Proc: Empty Pipe	Select:Out of Specification (default)FailureInformationMaintenance RequiredFunction Check ①
C1.10.4	Proc: Signal Lost	Select:Out of Specification (default)FailureInformationMaintenance RequiredFunction Check ①
C1.10.6	Config: Totaliser	Select:Out of Specification (default)FailureInformationMaintenance RequiredFunction Check ①
C1.10.8	Electr: Power Failure	Select:Information (default)Maintenance RequiredFunction CheckOut of SpecificationFailure ①
C1.10.7	Electr: IO Connection	Select:Out of Specification (default)FailureInformationMaintenance RequiredFunction Check ①

① Below mentioned definitions for both diagnosis and status will be internally used for PROFIBUS diagnosis and status handling of the classifications stated below which will be possible for the variable "Event groups":

if condensed status and diagnosis handling selected:

"F"	Failure	diagnosis: DIA_MAINTENANCE_ALARM (Maintenance alarm {40})
		status: BAD - maintenance alarm
"S"	Out of specification	diagnosis: DIA_MAINTENANCE_DEMAND (Maintenance demanded {41})
		status: UNCERTAIN - process related, no maintenance
"M"	Maintenance required	diagnosis: DIA_MAINTENANCE (Maintenance required {37})
		status: GOOD - maintenance demanded
"C"	Checks in progress	diagnosis: DIA_FUNCTION_CHECK (Function check {42})
		status: GOOD - function check
"I"	Information	diagnosis: NO DIAGNOSIS EVENTS (no diagnosis events) ①
		status: GOOD - ok

① Bit "EXTENSION_AVAILABLE" of parameter DIAGNOSIS will be set if at least one Bit of parameter "DIAGNOSIS_EXTENSION" has been set.

if classic status and diagnosis handling selected:

"F"	Failure	diagnosis: DIA_HW_ELECTR (Hardware failure electronics (24))
		status: BAD - Device Failure
"S"	Out of specification	diagnosis: DIA_MEASUREMENT (Measurement failure (29))
		status: UNCERTAIN - sensor conver. not accur.
"M"	Maintenance required	diagnosis: DIA_MAINTENANCE (Maintenance required (37))
		status: GOOD (NC) - maintenance required
"C"	Checks in progress	diagnosis: NO DIAGNOSIS EVENTS (Status OK – function check only
		status: UNCERTAIN - simulated value (Function Check)
"I"	Information	diagnosis: NO DIAGNOSIS EVENTS (no diagnosis events) ①
		status: GOOD - ok

① Bit "EXTENSION_AVAILABLE" of parameter DIAGNOSIS will be set if at least one Bit of parameter "DIAGNOSIS_EXTENSION" has been set.

No.	Function	Settings / descriptions
-----	----------	-------------------------

C3 I/O Totaliser

C3.1	FB3 Totaliser 1	Set function of Totaliser _ _ stands for 1, 2, 3 (= Totaliser 1, 2, 3)
C3.2	FB4 Totaliser 2	
C3.3	FB5 Totaliser 3	
C3._1	Totaliser Function	Select: Sum Total (counts positive and negative values) / + Total (counts only the positive values) / - Total (counts only the negative values) / Stop Totaliser (totaliser is stopped, no counting) / All As Positive (neg. input will be multiplied with -1.0) / All As Negative (pos. values will be multiplied with 1.0)
C3._2	Measurement	Select: Volume Flow / Mass Flow
C3._3	Unit	Select: m ³ , L, ml, hl, in ³ , ft ³ , yd ³ , gal, lG, barrel, kg, g, t, oz, lb, STon, LTon
C3._4	Preset Value	Predefines a threshold (using high/low limit value of the totaliser affected; the THRESHOLD bit will be set in the long status information bytes of the interface if the actual value of the totaliser is outside these limits. This can be also used for a status output.
C3._5	Reset Totaliser	The current value of the totaliser can be set to zero.
		Select: No / Yes (Reset Totaliser 1...3)
C3._6	Error Behaviour	Defines the behaviour of this function block in case of errors.
		Select: hold meas. value / ignore error / stop totaliser
		hold meas. value: Totalisation is continued based on the last incoming value with good status before the first occurrence of bad status. ignore error: Totalisation is continued using the input values despite the bad status. The status is ignored. stop totaliser: Totalisation is stopped during occurrence of bad status of incoming values.
C3._7	Information	Serial no. of the I/O board, software version no. and production date of the circuit board will be displayed

C4 I/O PROFIBUS

C4	I/O PROFIBUS	Using the menu functions mentioned below you will be able to control basically the five analog input blocks of this PROFIBUS device. These eight menus are identical so they are grouped together and their functions are described in one go.
C4.1	FB1 Analog Inp.	There are 6 analog input blocks. _ stands for the 6 analog input blocks: FB1 (_ = 1), FB2 (_ = 2), FB6 (_ = 3), FB7 (_ = 4), FB8 (_ = 5), FB9 (_ = 6)
C4.2	FB2 Analog Inp.	
C4.3	FB6 Analog Inp.	
C4.4	FB7 Analog Inp.	
C4.5	FB8 Analog Inp.	
C4.6	FB9 Analog Inp.	
C4._1	Measurement	Select measurement value for the analog input blocks: Volume Flow / Mass Flow / Velocity of Sound / Flow Speed / Gain / SNR / Electr. Temperature / Supply
C4._2	Time Constant	Set time constant for this function block (_).
C4._3	Error Behaviour	Defines the behaviour of this function block in case of errors. Select: hold value / ignore error / replace value
		hold value: Last valid OUT value stored will be used as OUT value. ignore error: OUT has the wrong calculated value and status "Bad" as calculated. replace value: The "replacement value" will be used as OUT value.
C4._4	Replacement Value	Available, if the error behaviour "Replace Value" is selected. Defines the value that replaces the measured value at this function block in case of an error.

C5.1 Device Info

C5 Device

In this menu all functions are grouped that have no effect on the measurement or any output directly.		
C5.1.1	Tag	Tag descriptor of the physical block of the PROFIBUS module will be displayed. The Tag descriptor provides an application specific reference to the blocks. It will be assigned by the user of the device. The Tag descriptor is an octet string (a visible string will be preferred) consisting of 32 byte. The first 21 characters will be displayed only!
C5.3	1st Meas. Page	
C5.3.1	Function	Specify number of measured value lines (font size)
		One Line / Two Lines / Three Lines
C5.3.2	Measurement Line 1	Select the measurement of the 1st line:
		Select: Volume Flow / Velocity of Sound / Mass Flow / Flow Speed / Gain / SNR / Diag. Flow Speed / Diag. Velocity of Sound / Diag. Gain / Diag. SNR
C5.3.8	Measurement Line 2	Specify measurement of 2nd line (only available if this Line 2 is activated)
		Select: Bargraph / Volume Flow / Velocity of Sound / Mass Flow / Flow Speed / Gain / SNR / Diag. Flow Speed / Diag. Velocity of Sound / Diag. Gain / Diag. SNR / FB3 Total. 1 Volume / FB3 Total. 1 Mass / FB4 Total. 2 Volume / FB4 Total. 2 Mass / FB5 Total. 3 Volume / FB5 Total. 3 Mass / Operating Hours
C5.3.10	Measurement Line 3	Specify measurement of 3rd line (only available if this Line 3 is activated)
		Select: Volume Flow / Velocity of Sound / Mass Flow / Flow Speed / Gain / SNR / Diag. Flow Speed / Diag. Velocity of Sound / Diag. Gain / Diag. SNR / FB3 Total. 1 Volume / FB3 Total. 1 Mass / FB4 Total. 2 Volume / FB4 Total. 2 Mass / FB5 Total. 3 Volume / FB5 Total. 3 Mass / Operating Hours
C5.4	2. Meas. page	Setting of the measurement for the second measuring page.
		For PROFIBUS devices this page shows only the PROFIBUS values FB1...FB8.
C5.4.1	Measurement Line 1	Select the measurement of the 1st, 2nd and 3rd line: FB1 Analog inp. 1 / FB2 Analog inp. 2 / FB3 Totaliser 1 / FB4 Totaliser 2 / FB5 Totaliser 3 / FB6 Analog inp. 3 / FB7 Analog inp. 4 / FB8 Analog inp. 5 / FB9 Analog inp. 6
C5.4.3	Measurement Line 2	
C5.4.5	Measurement Line 3	
C5.4.2	Format 1.line	Fixed number of digits after the decimal point or automatic, where the number of digits is automatically adjusted to the available space.
C5.4.4	Format 2.line	
C5.4.6	Format 3.line	
C5.8	Physical Block	This menu is only available, if a PROFIBUS interface is present.
C5.8.1	Station Address	Selects the PROFIBUS station address of the device.
		The PROFIBUS address can also be changed using the PROFIBUS service "set_slave_add". The input range is 0...125 according to the PROFIBUS specification. Address 126 is the default address and cannot be set via the PROFIBUS service "set_slave_add" - use menu instead to reset to default address.
C5.8.7	Information	Available if there is a PROFIBUS interface in existence; the below mentioned information will be displayed about the PROFIBUS interface: Hardware Revision of the PROFIBUS interface used Software Version of the PROFIBUS interface used Date of Compilation (same as B3.5)
C5.8.2	Diag. extension	Content of the PROFIBUS diagnosis extension is displayed.
C5.8.3	Diag. extension i	Content of the internal diagnosis extension is displayed.

C5.8.4	Diag. extension h	h = history
		Content of the PROFIBUS diagnosis extension history is displayed. Shows PROFIBUS diagnosis extension information of all PROFIBUS diagnosis extension bits which are set since last reset (all bits reset to zero – use service menu D2.2.9 to reset this parameter)
C5.8.5	Diag. extension ih	h = history
		Content of the internal PROFIBUS diagnosis extension history is displayed. Shows internal PROFIBUS diagnosis extension information of all internal PROFIBUS diagnosis extension bits which are set since last reset (all bits reset to zero – use service menu D2.2.10 to reset this parameter)
C5.8.6	Identification No.	Sets different device modes for the cyclic configuration of the PROFIBUS interface. Select: UFC400: all manufacturer specific parameters / functions supported Profile: profile defined parameters / functions supported only Autom.: (default setting) PROFIBUS configuration (UFC400 or Profile) will be selected automatically by the PROFIBUS master itself without interaction by the user. The active selection is configured during startup by using the Set_Prm and/or Set_Slave_Add service. No additional acyclic parameter settings required.
C5.8.8	Condensed Status	Defines the general method how the device handles status and diagnostics: On: Condensed status and diagnosis information according PROFIBUS Profile 3.02 will be used Off: Classic status and diagnosis information according PROFIBUS Profile 3.02 will be used

5.4 Menu D, Service

This menu is protected. You will need to use the service password to gain access.

No.	Function	Settings / descriptions
D4.0	Service Parameter	
D4.7.0	Identification No.	Same as C5.8.6
D4.8.0	PB Cold Start	Initiates a PROFIBUS cold start. During a PROFIBUS cold start nearly all parameter values of the whole device will be set to their default values (Exceptions are the PROFIBUS address and the identification No.). The PROFIBUS cold start will be carried out without disconnecting an already established connection to a PROFIBUS master system. Select: No (terminates this function) / Yes (PROFIBUS cold start will be carried out at once)

5.5 Status messages and diagnostic information

Error type	Event group	Single event	Description	Actions to eliminate the event
F	F Electronics			
		PROFIBUS Failure	Error in the electronics due to an internal bus communication timeout or a hardware error.	Perform a power reset. If the status returns, contact the factory.
F	F Configuration			
		PROFIBUS Config.	Invalid PROFIBUS configuration.	Check PROFIBUS configuration or reset to factory configuration (D2.2.8).
		Tot 1 FB3 Unit Error	The totaliser is not counting, because the unit is not known.	Check unit in totaliser 1 FB3 or reset to factory settings (D2.2.8).
		Tot 2 FB4 Unit Error		Check unit in totaliser 2 FB4 or reset to factory settings (D2.2.8).
		Tot 3 FB5 Unit Error		Check unit in totaliser 3 FB5 or reset to factory settings (D2.2.8)
C	C Configuration			
		PROFIBUS Sim/Man Active	A simulation function in the PROFIBUS component is active and in use.	Switch off PROFIBUS simulation.
		Tot 1 FB3 Sim. Active	A simulation function in the PROFIBUS component is active and in use. (for internal testing purpose only)	Switch off PROFIBUS simulation.
		Tot 2 FB4 Sim. Active	A simulation function in the PROFIBUS component is active and in use. (for internal testing purpose only)	Switch off PROFIBUS simulation.
		Tot 3 FB5 Sim. Active	A simulation function in the PROFIBUS component is active and in use. (for internal testing purpose only)	Switch off PROFIBUS simulation.
		Tot 1 FB3 Man. Active	The manual mode in the PROFIBUS component is active.	Switch off PROFIBUS manual mode.
		Tot 2 FB4 Man. Active	The manual mode in the PROFIBUS component is active.	Switch off PROFIBUS manual mode.
		Tot 3 FB5 Man. Active	The manual mode in the PROFIBUS component is active.	Switch off PROFIBUS manual mode.
S	S Electronics			
		Electr.Temp. Out of Spec	The electronics temperature measured inside the electronics housing exceeds the limits.	Move electronics away from process influences. Protect the electronics against direct sunlight.

M	M Electronics			
		Mem. Life Exceeded	The number of maximum write cycles is exceeded for EEPROM or FRAM or Flash (if detected).	Exchange electronics assembly.
S	S Config: Totaliser			
		Tot 1 FB3 Overflow	Counter FB3 had an overflow. After the overflow it started again at zero. (not supported till now)	Check totaliser format.
		Tot 2 FB4 Overflow	Counter FB4 had an overflow. After the overflow it started again at zero. (not supported till now)	
		Tot 3 FB5 Overflow	Counter FB5 had an overflow. After the overflow it started again at zero. (not supported till now)	
I	I Electr: Power Failure			
		Tot 1 FB3 Power Failure	Totaliser 1 invalid due to power failure.	Check Totaliser value. Reset Errors (A3.1).
		Tot 2 FB4 Power Failure	Totaliser 2 invalid due to power failure.	
		Tot 3 FB5 Power Failure	Totaliser 3 invalid due to power failure.	
		Power Failure Detected	Power failure. Totalisers did not run during that time.	Reset Errors (A3.1).
I	I Electr. Operation Info.			
		PROFIBUS No Data	There is no cyclic data exchange established in connection with this UFC 400.	
		PROFIBUS Baudrate	The PROFIBUS RS485 interface is looking for a baudrate supported.	Check PROFIBUS terminal and connection.
		PROFIBUS Passivated	PROFIBUS module is passivated.	Disable PROFIBUS passivation.
		PROFIBUS Clear Data	PROFIBUS Clear Data active.	Start cyclic PROFIBUS communication.
		PROFIBUS Sync Mode	PROFIBUS Sync Mode active.	Disable Sync Mode.
		PROFIBUS Freeze Mode	PROFIBUS Freeze Mode active.	Disable Freeze Mode.
		Tot 1 Stopped	Tot 1 FB3 has stopped.	Select "Totaliser Function" and choose setting other than "Stop" (C3.1.1)
		Tot 2 Stopped	Tot 2 FB4 has stopped.	Select "Totaliser Function" and choose setting other than "Stop" (C3.2.1)
		Tot 3 Stopped	Tot 3 FB5 has stopped.	Select "Totaliser Function" and choose setting other than "Stop" (C3.3.1)
		Tot 1 FB3 Threshold	Tot 1 FB3 Threshold exceeded.	Reset Totaliser 1 FB3 (C3.1.4).
		Tot 2 FB4 Threshold	Tot 2 FB4 Threshold exceeded.	Reset Totaliser 2 FB4 (C3.2.4)
		Tot 3 FB5 Threshold	Tot 3 FB5 Threshold exceeded.	Reset Totaliser 3 FB5 (C3.3.4)









KROHNE product overview

- Electromagnetic flowmeters
- Variable area flowmeters
- Ultrasonic flowmeters
- Mass flowmeters
- Vortex flowmeters
- Flow controllers
- Level meters
- Temperature assemblies
- Pressure transmitters
- Analysis products
- Products and systems for the oil & gas industry
- Measuring systems for the marine industry

Head Office KROHNE Messtechnik GmbH
Ludwig-Krohne-Str. 5
47058 Duisburg (Germany)
Tel.: +49 203 301 0
Fax: +49 203 301 103 89
info@krohne.com

The current list of all KROHNE contacts and addresses can be found at:
www.krohne.com

KROHNE