



UFC 400 Supplementary instructions

Signal converter for ultrasonic flowmeters

Description of Foundation Fieldbus interface

Electronic Revision: ER 2.2.0_



The documentation is only complete when used in combination with the relevant documentation for the measuring sensor.

1	Safety instructions	3
<hr/>		
1.1	Scope of the document.....	3
1.2	Device description.....	3
2	Technical data	4
<hr/>		
2.1	Foundation Fieldbus data.....	4
3	Electrical connections	5
<hr/>		
3.1	Cable types	5
3.2	Shielding and grounding	5
3.3	Electrical connection of FOUNDATION Fieldbus	6
3.4	Topology of FF networks	7
4	Operation	8
<hr/>		
4.1	Settable functions.....	8
4.2	Description of the FF block system.....	9
4.3	Used abbreviations	9
4.4	Resource Block (RB)	10
4.5	Analog Input Block (AI 1...4)	31
4.6	FLOWTB (Flow Transducer Block).....	39
4.7	DIAGTB (Diagnose Transducer Block)	48
4.8	Integrator Block (IT)	55
4.9	Proportional Integral Derivative Block (PID)	62

1.1 Scope of the document

These instructions are supplementary to the standard product documentation of the signal converter. The details depicted therein, in particular the safety information are valid and should be adhered to. The present supplementary instructions provide additional information for the devices when being operated and connected to a Foundation Fieldbus.



INFORMATION!

The present supplementary instruction for the signal converter with Foundation Fieldbus interface, plus the software with the DD and CCF files are included in our scope of supply, in addition to those items delivered for the standard device.

1.2 Device description

This ultrasonic flowmeter is designed for the continuous measurement of actual volume flow, mass flow, flow speed, velocity of sound, gain, SNR and diagnosis value.

Exclusively for measuring conductive and / or non-conductive fluids in closed, completely filled pipeline circuits.

Your measuring device is supplied ready for operation. The factory settings for the operating data have been made in accordance with your order specifications.

The following version is available:

- Compact version (the signal converter is mounted directly on the measuring sensor)
- Remote version (electrical connection to the measuring sensor via signal cable)

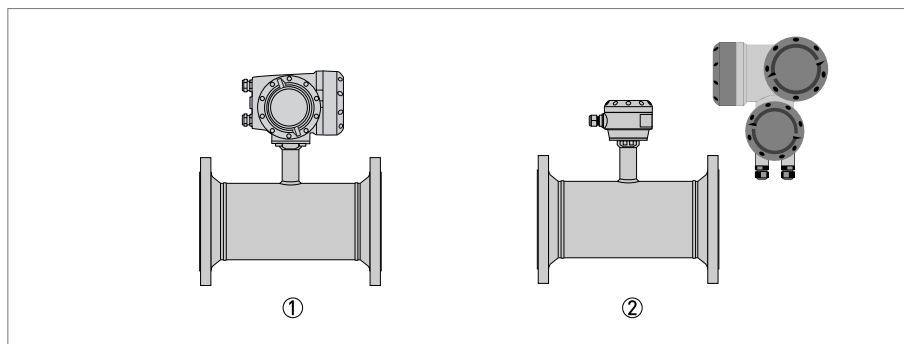

- ① Compact version
② Remote version

2.1 Foundation Fieldbus data

Description

Type	Ultrasonic flowmeter
Physical layer	Foundation Fieldbus protocol that agrees with IEC 61158-2 and FISCO model; galvanically isolated
Communication standard	H1
ITK version	6.1
NAMUR 107	Supported within FF field diagnosis (FF-912)

Data blocks

Function blocks	1 x Enhanced Resource Block (RB)
	1 x Customer Flow Transducer Block (FLOWTB)
	1 x Customer Diagnose Transducer Block (DIAGTB)
	4 x Analog Input Block (AI)
	2 x Integrator Block (IT)
	1 x Proportional Integral Derivate Block (PID)
Execution time	Analog Input Block: 10 ms
	Integrator Block: 15 ms
	Proportional Integral Derivate Block: 25 ms

Electrical connections

Device power supply	Not intrinsically safe: 9...32 VDC
	Intrinsically safe: 9...24 VDC
Basic current	10.5 mA
Maximum error current	16.5 mA (= basic current + error current = 10.5 mA + 6 mA)
Start current after 10 ms	14 mA
Polarity sensitivity	No
Minimum cycle time	250 ms

3.1 Cable types

The cable types are specified according to IEC 61158-2. Shielded cables offer the advantage of malfunction-free operation with adequate protection against electromagnetic influences, and make it possible to employ the full performance of the Foundation Fieldbus system.

Core cross-section	0.8 mm ² or AWG 18	0.32 mm ² or AWG 22	0.13 mm ² or AWG 26	1.25 mm ² or AWG 16
Cable type	A twisted pair, individually shielded	B individual or multiple twisted pairs with overall shield	C multiple twisted pairs, without shielding	D multiple non-twisted cables, without shielding
Max. length incl. branch line	1900 m / 6200 ft	1200 m / 3900 ft	400 m / 1300 ft	200 m / 650 ft

In non-hazardous locations, a maximum of 32 field devices can be connected to the network. For more data, refer to the table that follows.

Number of devices	Cable lengths for number of devices per branch line			
	1 device	2 devices	3 devices	4 devices
25...32	1 m / 3.3 ft	1 m / 3.3 ft	1 m / 3.3 ft	1 m / 3.3 ft
19...24	30 m / 100 ft	1 m / 3.3 ft	1 m / 3.3 ft	1 m / 3.3 ft
15...18	60 m / 200 ft	30 m / 100 ft	1 m / 3.3 ft	1 m / 3.3 ft
13...14	90 m / 300 ft	60 m / 200 ft	30 m / 100 ft	1 m / 3.3 ft
1..12	120 m / 400 ft	90 m / 300 ft	60 m / 200 ft	30 m / 100 ft

All bus segments must be fitted with a terminator at both ends.

3.2 Shielding and grounding

- For optimum electromagnetic compatibility of systems it is extremely important that the system components, and particularly the bus cables connecting the components, are shielded and that such shields - if possible - form an unbroken cover.
- Hence, it follows that, for use in non-hazardous duty systems, the cable shield should be grounded as often as possible.
- In Ex systems an adequate equipotential bonding in the hazardous and non-hazardous location along the entire Fieldbus installation is strongly recommended. Multiple grounding of the shield is of advantage.
- In explosion-proof systems the shielding must at least be connected at one end of the cable.
- NAMUR NE 21 compliance is given, provided the above recommended cable types are used.



INFORMATION!

The use of twisted and shielded cables is strongly recommended, otherwise EMC protection of the signal converter cannot be assured.

3.3 Electrical connection of FOUNDATION Fieldbus



INFORMATION!

The wiring between the device and the FOUNDATION Fieldbus cable is independent of polarity. The signal converter FOUNDATION Fieldbus interface will operate only if the additional power supply for the device is connected/available. For a detailed description of the electrical connections please refer to the standard signal converter handbook.

Connection to a spur

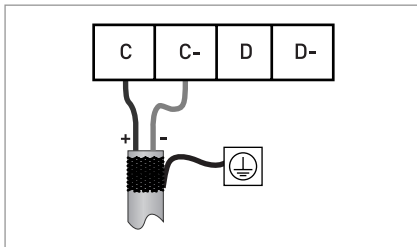

or

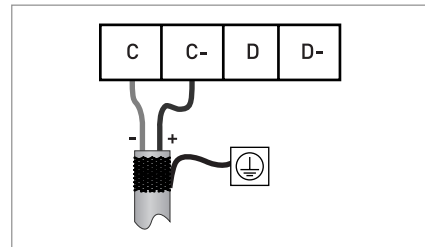

Connection to a trunk

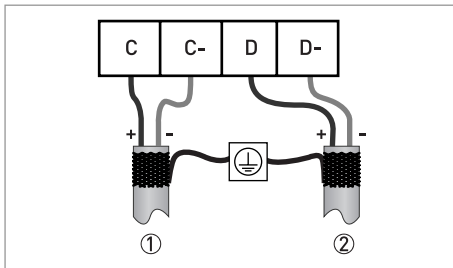

or

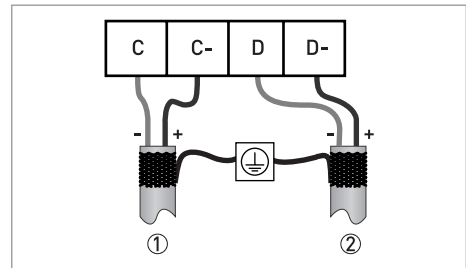

- ① e.g. incoming data lines
- ② e.g. outgoing data lines

3.4 Topology of FF networks

An example of mixed topology of FF networks is shown in the following example.

Connection is best made via short branch cables and T connectors. This connection type makes it possible to connect and disconnect the devices without interrupting the bus or the communication.

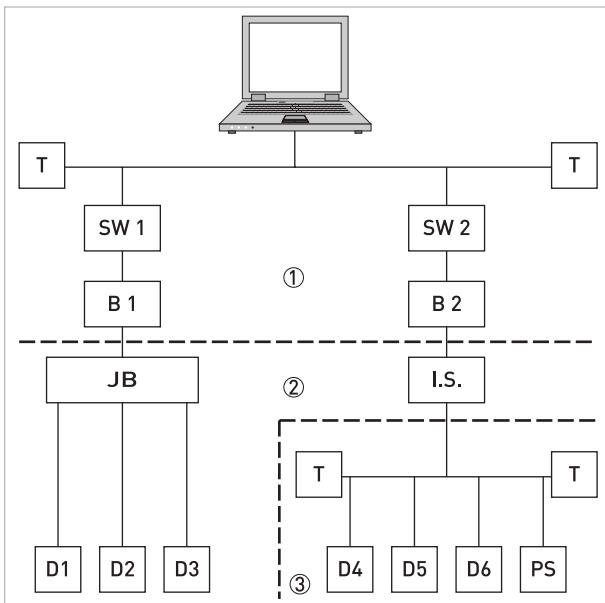

- ① HSE network
- ② H1 bus
- ③ Intrinsically safe, explosive area
- B1+B2 Bridge = coupling element for H1 bus and HSE network
- D1-D3 Device = field devices, own power supply, for non potentially explosive areas
- D4-D6 Intrinsically safe devices, external power supply, for potentially explosive areas
- I.S. Intrinsically safe barrier
- JB Junction box for field devices
- PS Power supply
- Switch = connection of multiple HSE sub networks
- T Terminator

4.1 Settable functions

- For Foundation Fieldbus the totalizers of the signal converter are not available!
- The following tables describe only the menus, functions and parameters that are different between the standard signal converter and the Foundation Fieldbus signal converter.
- For the electrical connections of the outputs, inputs and all settings of functions that are not listed in the following tables refer to the standard product documentation.

No.	Displayed text	Description and settings
-----	----------------	--------------------------

A quick setup

A2	Tag	Identifier for the measurement in a plant, appears in the display header (maximum 8 digits).
		Note: Only read, not changeable!

B test

B3.7	Foundation fieldbus	Display information about Foundation fieldbus interface.
------	---------------------	--

C setup

C5.1.1	Tag	Identifier for the measurement in a plant, appears in the display header (maximum 8 digits).
		Note: Only read, not changeable!
C3	Totalizer	Not available for Foundation Fieldbus devices!
C4	I/O HART	Not available for Foundation Fieldbus devices!
C5.4	2. meas. page	In case of Foundation Fieldbus device, the second measurement page is meant to check the output values of the different function blocks. Only Foundation Fieldbus values can be selected here. The analogue inputs are shown with exactly the value, seen on the bus system.
C5.4.1	measurement 1.line	Select: AI1...4 analog inp. / PID / INT1..2 integrator
C5.4.2	format 1.line	Fixed number of digits after the decimal point or automatic, where the number of digits is automatically adjusted to the available space.
C5.4.3	measurement 2.line	Select: AI1...4 analog inp. / PID / INT1..2 integrator
C5.4.4	format 2.line	Fixed number of digits after the decimal point or automatic, where the number of digits is automatically adjusted to the available space.
C5.4.5	measurement 3.line	Select: AI1...4 analog inp. / PID / INT1..2 integrator
C5.4.6	format 3.line	Fixed number of digits after the decimal point or automatic, where the number of digits is automatically adjusted to the available space.
C5.8	Foundation Field	-
C5.8.1	Simulate	Select: disabled / enabled
C5.8.2	Information	Display information about hardware and software versions, the calibration and test date of this interface.

4.2 Description of the FF block system

The Foundation Fieldbus is a Local Area Network (LAN) for connecting field devices like sensors and actuators. One of the main benefits of Foundation Fieldbus is line saving in comparison to the traditional 4...20 mA technology.

The different device functions are implemented in a block-based scheme within a user application. In this block scheme, a distinction is made between the Resource Block, Transducer Block and Function Block.

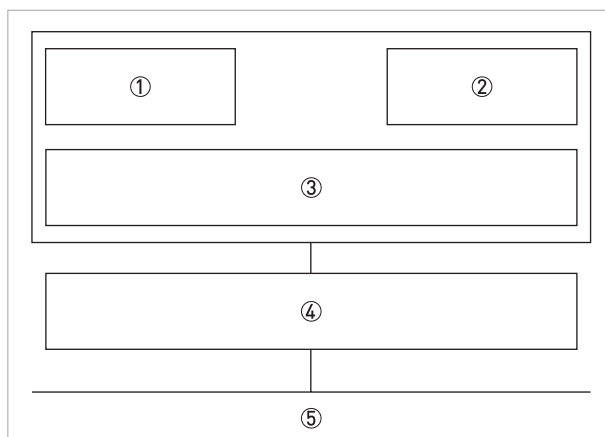

- ① Resource Block (RB)
- ② Transducer Block (TB)
- ③ Function Block (FB)
- ④ Device FF communication
- ⑤ Foundation Fieldbus

4.3 Used abbreviations

AI	Analogue Input Block	BLK	Block mode
IT	Integrator Block	MAN	Manual mode
PID	Proportional Integral Derivate Block	Mix	Mix mode (R, W and R/W)
RB	Resource Block	Auto	Automatic mode
TB	Transducer Block	OOS	Out Of Service mode
R	Read	OD	Object Directory
W	Write	SP	Set Point
R/W	Read and Write	IV	Initial Value
		PV	Process Value (factory settings)

4.4 Resource Block (RB)

The following tables list the Resource Block parameters in alphabetical order.

It describes characteristics of the Fieldbus device (e.g. device name, serial number, etc.) and is not included in the functional tasks of the signal converter for FF.

The following tables contain short parameter description, factory settings (Initial Value (IV)) and possible settings.

Parameter DD name	Access	Description and settings	Initial Value
ALERT_KEY Alert Key	R/W	The identification number of the plant unit. This information may be used in the host for sorting alarms, etc. Setting: 1...255	0
BLOCK_ERR Block Error	R	This parameter reflects the error status associated with the hardware or software components associated with a block. It is a bit string, so that multiple errors may be shown. Setting: <ul style="list-style-type: none"> • Other: Non-specific error active • Block Configuration: Error detected in block configuration • Link Configuration: Error detected in link configuration • Simulation Active: Simulation enabled in this block • Local Override: Output tracking of faultstate active • Device Fault State: Device faultstate set • Device Maintenance: Device needs maintenance soon • Input Failure: Process variable has bad status • Output Failure: Failure detected in output hardware • Memory Failure: Memory error detected • Lost Static Data: Static parameters cannot be recovered • Lost NV Data: Non-volatile parameters cannot be recovered • Readback Check: Failure detected in READBACK • Maintenance Needed: Device NEEDS maintenance NOW • Power Up: Recovery from power failure • Out Of Service: Block actual mode is out of service 	OOS (Out of Service)
MODE_BLK Block Mode	Mix	The actual, target, permitted and normal modes of the block.	-
TARGET Target	R/W	This is the mode requested by the operator. Only one mode from those allowed by the permitted mode parameter may be requested. Setting: Auto / OOS	OOS
ACTUAL Actual	R	This is the current mode of the block, which may differ from the target based on operating conditions. Its value is calculated as part of block execution. Setting: Auto / OOS	OOS
PERMITTED Permitted	R/W	Defines the modes which are allowed for an instance of the block. The permitted mode is configured based on application requirement. Setting: Auto / OOS	Auto OOS

Parameter DD name	Access	Description and settings	Initial Value
NORMAL Normal	R/W	This is the mode which the block should be set to during normal operating conditions.	Auto
		Setting: Auto / OOS	
ST_REV Static Revision	R	The revision level of the static data associated with the function block. The revision value will be incremented each time a static parameter value in the block is changed.	0
		Setting: 0...65535	
STRATEGY Strategy	R/W	The strategy field can be used to identify grouping of blocks. This data is not checked or processed by the block.	0
		Setting: 0...65535	
TAG_DESC Tag Description	R/W	The user description of the intended application of the block.	blanks
		Setting: ≤32 digits	
ACK_OPTION Acknowledge Option	R/W	Selection of whether alarms associated with the function block will be automatically acknowledged.	Uninitialized
		Setting: Disc Alm Auto Ack / Blk Alm Auto Ack / Fail Alm Auto Ack / Off Spec Alm Auto Ack / Maint Alm Auto Ack / Check Alm Auto Ack	
ALARM_SUM Alarm Summary	R	The current alert status, unacknowledged states, unreported states and disabled states of the alarms associated with the function block.	-
Current	R	The active status of each alarm.	Uninitialized
		Setting: Discrete Alarm / Block Alarm / Fail Alarm / Off Spec Alarm / Maintenance Alarm / Check Alarm	
Unacknowledged	R	The unacknowledged state of each alarm.	Uninitialized
		Setting: Disc Alm Unack / Block Alm Unack / Fail Alm Unack / Off Spec Alm Unack / Maint Alm Unack / Check Alm Unack	
Unreported	R	The unreported status of each alarm.	Uninitialized
		Setting: Disc Alm Unrep / Block Alm Unrep / Fail Alm Unrep / Off Spec Alm Unrep / Maint Alm Unrep / Check Alm Unrep	
Disabled	R/W	The disabled state of each alarm.	Uninitialized
		Setting: Disc Alm Disabled / Block Alm Disabled / Fail Alm Disabled / Off Spec Alm Disabled / Maint Alm Disabled / Check Alm Disabled	
BLOCK_ALM Block Alarm		The block alarm is used for all configuration, hardware, connection failure or system problems in the block. The cause of the alert is entered in the subcode field. The first alert to become active will set the "Active" status in the "Status" attribute. As soon as the "Unreported" status is cleared by the alert reporting task, another block alert may be reported without clearing the "Active" status, if the subcode has changed.	-
Unacknowledged	R/W	A discrete enumeration which is set to "Unacknowledged" when an alarm occurs, and set to "Acknowledged" by a write from a human interface device or other entity which can acknowledge that the alarm/event has been noticed.	Uninitialized
		Setting: Uninitialized / Acknowledged / Unacknowledged	

Parameter DD name	Access	Description and settings	Initial Value
Alarm State	R	A discrete enumeration which gives an indication of whether the alert is active and whether it has been reported.	Uninitialized
		Setting: Uninitialized / Clear - reported / Clear - not reported / Active - reported / Active - not reported	
Time Stamp	R	The time when evaluation of the block was started and a change in alarm/event state was detected that is unreported. The time stamp value will be maintained constant until alert confirmation has been received - even if another change of state occurs.	Uninitialized
		Setting: MM / DD / YY (Month / Day / Year) HH:MM:SS (Hour:Minute:Second)	
Subcode	R	An enumeration specifying the cause of the alert to be reported.	Other
		Setting: Other / Block Configuration / Link Configuration / Simulation Active / Local Override / Device Fault State / Device Maintenance / Input Failure / Output Failure / Memory Failure / Lost Static Data / Lost NV Data / Readback Check / Maintenance Needed / Power Up / Out Of Service	
Value	R	The value of the associated parameter at the time the alert was detected.	0
		Setting: 0...255	
CLR_FSTATE Clear Fault State	R/W	Writing a "Clear" to this parameter will clear the device fault state if the field condition, if any, has cleared.	Off
		Setting: Uninitialized / Off / Clear	
CONFIRM_TIME Confirm Time	R/W	The minimum time between retries of alert reports.	640000
		Setting: 0...4294967295 in [1/32 ms]	
CYCLE_SEL Cycle Selection	R/W	Used to select the block execution method for this resource.	Uninitialized
		Setting: Scheduled / Block execution	
CYCLE_TYPE Cycle Type	R	Identifies the block execution methods available for this resource.	Scheduled Block execution
		Setting: Scheduled / Block execution	
DD_RESOURCE DD Resource	R	String identifying the tag of the resource which contains the Device Description for this resource.	blanks
		Setting: ≤ 32 digits	
DD_REV DD Revision	R	Revision of the DD associated with the resource - used by an interface device to locate the DD file for the resource.	Dependent on device version.
		Setting: Dependent on device version.	
DEV_REV Device Revision	R	Manufacturer revision number associated with the resource - used by an interface device to locate the DD file for the resource.	Dependent on device version.
		Setting: Dependent on device version.	

Parameter DD name	Access	Description and settings	Initial Value
DEV_TYPE Device Type	R	Manufacturer's model number associated with the resource - used by interface devices to locate the DD file for the resource. Setting: UFC400	UFC400
FAULT_STATE Fault State	R	Condition set by loss of communication to an output block, failure promoted to an output block or a physical contact. When fault state condition is set, then output function blocks will perform their "FSTATE" actions. Setting: Uninitialized / Off / Clear	Clear
FD_CHECK_ACTIVE Check Active	R	This parameter reflects the error conditions that are being detected as active as selected for this category. It is a bit string, so that multiple conditions may be shown. See section 2.9. Setting: (00) Check / (01) Electronics : Operation Info / (08) Electronics : Power Fail / (10) Configuration : Totaliser / (11) Process : Signal Unreliable / (12) Process : Signal Lost / (13) Process : Empty Pipe / (14) Electronics : IO Connection / (15) Process : Current input / (16) M Process / (17) M Configuration / (18) M Electronics / (19) M Sensor / (20) S Process / (21) S Configuration / (22) S Electronics / (23) S Sensor / (24) C Process / (25) C Configuration / (26) C Electronics / (27) C Sensor / (28) F Process / (29) F Configuration / (30) F Electronics / (31) F Sensor	-
FD_CHECK_ALM Check Alarm		This parameter is used primarily to broadcast a change in the associated active conditions, which are not masked, for this alarm category to a Host System.	-
Unacknowledged	R/W	A discrete enumeration which is set to "Unacknowledged" when an alarm occurs, and set to "Acknowledged" by a write from a human interface device or other entity which can acknowledge that the alarm/event has been noticed. Setting: Uninitialized / Acknowledged / Unacknowledged	Uninitialized
Alarm State	R	A discrete enumeration which gives an indication of whether the alert is active and whether it has been reported. Setting: Uninitialized / Clear - reported / Clear - not reported / Active - reported / Active - not reported	Uninitialized
Time Stamp	R	The time when evaluation of the block was started and a change in alarm/event state was detected that is unreported. The time stamp value will be maintained constant until alert confirmation has been received - even if another change of state occurs. Setting: MM / DD / YY (Month / Day / Year) HH:MM:SS (Hour:Minute:Second)	Uninitialized
Subcode	R	An enumeration specifying the cause of the alert to be reported.	-
Value	R	The value of the associated parameter at the time the alert was detected.	-

Parameter DD name	Access	Description and settings	Initial Value
FD_CHECK_MAP Check Map	R/W	This parameter enables or disables conditions to be detected as active for this alarm category. Setting: (00) Check / (01) Electronics : Operation Info / (08) Electronics : Power Fail / (10) Configuration : Totaliser / (11) Process : Signal Unreliable / (12) Process : Signal Lost / (13) Process : Empty Pipe / (14) Electronics : IO Connection / (15) Process : Current input / (16) M Process / (17) M Configuration / (18) M Electronics / (19) M Sensor / (20) S Process / (21) S Configuration / (22) S Electronics / (23) S Sensor / (24) C Process / (25) C Configuration / (26) C Electronics / (27) C Sensor / (28) F Process / (29) F Configuration / (30) F Electronics / (31) F Sensor	(24) (25) (26) (27)
FD_CHECK_MASK Check Mask	R/W	This parameter allows the user to suppress any single or multiple conditions that are active, in this category, from being broadcast to the host through the alarm parameter. Setting: (00) Check / (01) Electronics : Operation Info / (08) Electronics : Power Fail / (10) Configuration : Totaliser / (11) Process : Signal Unreliable / (12) Process : Signal Lost / (13) Process : Empty Pipe / (14) Electronics : IO Connection / (15) Process : Current input / (16) M Process / (17) M Configuration / (18) M Electronics / (19) M Sensor / (20) S Process / (21) S Configuration / (22) S Electronics / (23) S Sensor / (24) C Process / (25) C Configuration / (26) C Electronics / (27) C Sensor / (28) F Process / (29) F Configuration / (30) F Electronics / (31) F Sensor	
FD_CHECK_PRI Check Priority	R/W	This parameter allows the user to specify the priority of this alarm category. Setting: 0...15	0
FD_FAIL_ACTIVE Fail Active	R	This parameter reflects the error conditions that are being detected as active as selected for this category. It is a bit string, so that multiple conditions may be shown. See section 2.9. Setting: (00) Check / (01) Electronics : Operation Info / (08) Electronics : Power Fail / (10) Configuration : Totaliser / (11) Process : Signal Unreliable / (12) Process : Signal Lost / (13) Process : Empty Pipe / (14) Electronics : IO Connection / (15) Process : Current input / (16) M Process / (17) M Configuration / (18) M Electronics / (19) M Sensor / (20) S Process / (21) S Configuration / (22) S Electronics / (23) S Sensor / (24) C Process / (25) C Configuration / (26) C Electronics / (27) C Sensor / (28) F Process / (29) F Configuration / (30) F Electronics / (31) F Sensor	Uninitialized
FD_FAIL_ALM Fail Diagnostic Alarm		This parameter is used primarily to broadcast a change in the associated active conditions, which are not masked, for this alarm category to a Host System.	-
Unacknowledged	R/W	A discrete enumeration which is set to "Unacknowledged" when an alarm occurs, and set to "Acknowledged" by a write from a human interface device or other entity which can acknowledge that the alarm/event has been noticed. Setting: Uninitialized / Acknowledged / Unacknowledged	Uninitialized
Alarm State	R	A discrete enumeration which gives an indication of whether the alert is active and whether it has been reported. Setting: Uninitialized / Clear - reported / Clear - not reported / Active - reported / Active - not reported	Uninitialized

Parameter DD name	Access	Description and settings	Initial Value
Time Stamp	R	The time when evaluation of the block was started and a change in alarm/event state was detected that is unreported. The time stamp value will be maintained constant until alert confirmation has been received - even if another change of state occurs. Setting: MM / DD / YY (Month / Day / Year) HH:MM:SS (Hour:Minute:Second)	Uninitialized
Subcode	R	An enumeration specifying the cause of the alert to be reported.	-
Value	R	The value of the associated parameter at the time the alert was detected.	-
FD_FAIL_MAP Fail Map	R/W	This parameter enables or disables conditions to be detected as active for this alarm category. Setting: (00) Check / (01) Electronics : Operation Info / (08) Electronics : Power Fail / (10) Configuration : Totaliser / (11) Process : Signal Unreliable / (12) Process : Signal Lost / (13) Process : Empty Pipe / (14) Electronics : IO Connection / (15) Process : Current input / (16) M Process / (17) M Configuration / (18) M Electronics / (19) M Sensor / (20) S Process / (21) S Configuration / (22) S Electronics / (23) S Sensor / (24) C Process / (25) C Configuration / (26) C Electronics / (27) C Sensor / (28) F Process / (29) F Configuration / (30) F Electronics / (31) F Sensor	(28) (29) (30) (31)
FD_FAIL_MASK Fail Mask	R/W	This parameter allows the user to suppress any single or multiple conditions that are active, in this category, from being broadcast to the host through the alarm parameter. Setting: (00) Check / (01) Electronics : Operation Info / (08) Electronics : Power Fail / (10) Configuration : Totaliser / (11) Process : Signal Unreliable / (12) Process : Signal Lost / (13) Process : Empty Pipe / (14) Electronics : IO Connection / (15) Process : Current input / (16) M Process / (17) M Configuration / (18) M Electronics / (19) M Sensor / (20) S Process / (21) S Configuration / (22) S Electronics / (23) S Sensor / (24) C Process / (25) C Configuration / (26) C Electronics / (27) C Sensor / (28) F Process / (29) F Configuration / (30) F Electronics / (31) F Sensor	(28) (29) (30) (31)
FD_FAILK_PRI Fail Priority	R/W	This parameter allows the user to specify the priority of this alarm category. Setting: 0...15	0
FD_EXTENDED_ACTIVE_1 FD_EXTENDED_ACTIVE_1	R	An optional parameter to allow the user finer detail on conditions causing an active condition in the FD_*_ACTIVE parameter. Setting: (00) Optical Interf. Active / (01) Disp. 2 Overrange / (02) Disp. 1 Overrange / (06) RB is set to OOS / (07) Fieldbus No Connection / (11) Status Out B Active / (13) Status Out A Active / (14) Control In B Active / (15) Control In A Active / (30) Sensor Starting up / (31) Zero Calibr. Running	Uninitialized
FD_EXTENDED_ACTIVE_2 FD_EXTENDED_ACTIVE_2	R	An optional parameter to allow the user finer detail on conditions causing an active condition in the FD_*_ACTIVE parameter. Setting: (20) Disp. 2 no measure values / (21) Dsp. 1 no measure values / (28) IO B No Value for Binary Output / (29) IO B No Value for Current Output / (30) IO A No Value for Binary Output / (31) IO A No Value for Current Output	Uninitialized

Parameter DD name	Access	Description and settings	Initial Value
FD_EXTENDED_ ACTIVE_3 FD_EXTENDED_ ACTIVE_3	R	An optional parameter to allow the user finer detail on conditions causing an active condition in the FD_*_ACTIVE parameter.	Uninitialized
		Setting: (00) Reserved	
FD_EXTENDED_ ACTIVE_4 FD_EXTENDED_ ACTIVE_4	R	An optional parameter to allow the user finer detail on conditions causing an active condition in the FD_*_ACTIVE parameter.	Uninitialized
		Setting: (00) Reserved	
FD_EXTENDED_ ACTIVE_5 FD_EXTENDED_ ACTIVE_5	R	An optional parameter to allow the user finer detail on conditions causing an active condition in the FD_*_ACTIVE parameter.	Uninitialized
		Setting: (00) Reserved	
FD_EXTENDED_ ACTIVE_6 FD_EXTENDED_ ACTIVE_6	R	An optional parameter to allow the user finer detail on conditions causing an active condition in the FD_*_ACTIVE parameter.	Uninitialized
		Setting: (00) Reserved	
FD_EXTENDED_ ACTIVE_7 FD_EXTENDED_ ACTIVE_7	R	An optional parameter to allow the user finer detail on conditions causing an active condition in the FD_*_ACTIVE parameter.	Uninitialized
		Setting: (00) Reserved	
FD_EXTENDED_ ACTIVE_8 FD_EXTENDED_ ACTIVE_8	R	An optional parameter to allow the user finer detail on conditions causing an active condition in the FD_*_ACTIVE parameter.	Uninitialized
		Setting: (00) Reserved	
FD_EXTENDED_ ACTIVE_9 FD_EXTENDED_ ACTIVE_9	R	An optional parameter to allow the user finer detail on conditions causing an active condition in the FD_*_ACTIVE parameter.	Uninitialized
		Setting: (00) Reserved	
FD_EXTENDED_ ACTIVE_10 FD_EXTENDED_ ACTIVE_10	R	An optional parameter to allow the user finer detail on conditions causing an active condition in the FD_*_ACTIVE parameter.	Uninitialized
		Setting: (00) Reserved	
FD_EXTENDED_ ACTIVE_11 FD_EXTENDED_ ACTIVE_11	R	An optional parameter to allow the user finer detail on conditions causing an active condition in the FD_*_ACTIVE parameter.	Uninitialized
		Setting: (28) Time of Flight / (29) Path 3 unreliable / (30) Path 2 unreliable / (31) Path 1 unreliable	
FD_EXTENDED_ ACTIVE_12 FD_EXTENDED_ACTIV E_12	R	An optional parameter to allow the user finer detail on conditions causing an active condition in the FD_*_ACTIVE parameter.	Uninitialized
		Setting: (29) Signal lost path 3 / (30) Signal lost path 2 / (31) Signal lost path 1	

Parameter DD name	Access	Description and settings	Initial Value
FD_EXTENDED_ ACTIVE_13 FD_EXTENDED_ACTIV E_13	R	An optional parameter to allow the user finer detail on conditions causing an active condition in the FD_*_ACTIVE parameter.	Uninitialized
		Setting: [31] Empty Pipe	
FD_EXTENDED_ ACTIVE_14 FD_EXTENDED_ ACTIVE_14	R	An optional parameter to allow the user finer detail on conditions causing an active condition in the FD_*_ACTIVE parameter.	Uninitialized
		Setting: [28] IO B Connect. Control Input / [29] IO B Connect. Current In-/Output / [30] IO A Connect. Control Input / [31] IO A Connect. Current In-/Output	
FD_EXTENDED_ ACTIVE_15 FD_EXTENDED_ ACTIVE_15	R	An optional parameter to allow the user finer detail on conditions causing an active condition in the FD_*_ACTIVE parameter.	Uninitialized
		Setting: [30] IO B Error Current / [31] IO A Error Current	
FD_EXTENDED_ ACTIVE_16 FD_EXTENDED_ ACTIVE_16	R	An optional parameter to allow the user finer detail on conditions causing an active condition in the FD_*_ACTIVE parameter.	Uninitialized
		Setting: [00] Reserved	
FD_EXTENDED_ ACTIVE_17 FD_EXTENDED_ ACTIVE_17	R	An optional parameter to allow the user finer detail on conditions causing an active condition in the FD_*_ACTIVE parameter.	Uninitialized
		Setting: [30] Backup 2 Data Faulty / [31] Backup 1 Data Faulty	
FD_EXTENDED_ ACTIVE_18 FD_EXTENDED_ ACTIVE_18	R	An optional parameter to allow the user finer detail on conditions causing an active condition in the FD_*_ACTIVE parameter.	Uninitialized
		Setting: [29] Backplane Difference / [30] Factory Data Faulty / [31] Backplane Data Faulty	
FD_EXTENDED_ ACTIVE_19 FD_EXTENDED_ ACTIVE_19	R	An optional parameter to allow the user finer detail on conditions causing an active condition in the FD_*_ACTIVE parameter.	Uninitialized
		Setting: [00] Reserved	
FD_EXTENDED_ ACTIVE_20 FD_EXTENDED_ ACTIVE_20	R	An optional parameter to allow the user finer detail on conditions causing an active condition in the FD_*_ACTIVE parameter.	Uninitialized
		Setting: [31] Velocity Out of Range	
FD_EXTENDED_ ACTIVE_21 FD_EXTENDED_ ACTIVE_21	R	An optional parameter to allow the user finer detail on conditions causing an active condition in the FD_*_ACTIVE parameter.	Uninitialized
		Setting: [03] IO B Overage Binary Output / [04] IO B Overage Current Output / [05] IO B Overage Current In-/Output / [06] IO A Overage Binary Output / [07] IO A Overage Current Output / [09] IO A Overage Current In-/Output	
FD_EXTENDED_ ACTIVE_22 FD_EXTENDED_ ACTIVE_22	R	An optional parameter to allow the user finer detail on conditions causing an active condition in the FD_*_ACTIVE parameter.	Uninitialized
		Setting: [29] Conv. Zero too large	

Parameter DD name	Access	Description and settings	Initial Value
FD_EXTENDED_ACTIVE_23 FD_EXTENDED_ACTIVE_23	R	An optional parameter to allow the user finer detail on conditions causing an active condition in the FD_*_ACTIVE parameter. Setting: (00) Reserved	Uninitialized
FD_EXTENDED_ACTIVE_24 FD_EXTENDED_ACTIVE_24	R	An optional parameter to allow the user finer detail on conditions causing an active condition in the FD_*_ACTIVE parameter. Setting: (00) Reserved	Uninitialized
FD_EXTENDED_ACTIVE_25 FD_EXTENDED_ACTIVE_25	R	An optional parameter to allow the user finer detail on conditions causing an active condition in the FD_*_ACTIVE parameter. Setting: (06) IO B Simulation Active / (07) IO B Sim. Binary Output / (08) IO B Sim. Current In-/Output / (09) IO B Sim. Limit Sw./Current Out / (10) IO A Sim. Binary Output / (11) IO A Sim. Current In-/Output / (12) IO A Sim. Limit Sw./Current Out / (30) VoS Simulation Active / (31) Flow Simulation Active	Uninitialized
FD_EXTENDED_ACTIVE_26 FD_EXTENDED_ACTIVE_26	R	An optional parameter to allow the user finer detail on conditions causing an active condition in the FD_*_ACTIVE parameter. Setting: (00) Reserved	Uninitialized
FD_EXTENDED_ACTIVE_27 FD_EXTENDED_ACTIVE_27	R	An optional parameter to allow the user finer detail on conditions causing an active condition in the FD_*_ACTIVE parameter. Setting: (00) Reserved	Uninitialized
FD_EXTENDED_ACTIVE_28 FD_EXTENDED_ACTIVE_28	R	An optional parameter to allow the user finer detail on conditions causing an active condition in the FD_*_ACTIVE parameter. Setting: (00) Reserved	Uninitialized
FD_EXTENDED_ACTIVE_29 FD_EXTENDED_ACTIVE_29	R	An optional parameter to allow the user finer detail on conditions causing an active condition in the FD_*_ACTIVE parameter. Setting: (02) IO B Binary Output Config / (03) IO B Current In-/Output Config / (04) IO A Binary Output Config / (05) IO A Current In-/Output Config. / (10) IO2 Configuration / (11) IO1 Configuration / (12) Display Config. / (26) Process Input Config. / (30) DM Configuration / (31) BM Configuration	Uninitialized
FD_EXTENDED_ACTIVE_30 FD_EXTENDED_ACTIVE_30	R	An optional parameter to allow the user finer detail on conditions causing an active condition in the FD_*_ACTIVE parameter. Setting: (01) IO B Failure / (02) IO A Failure / (07) IO 2 Failure / (08) IO 1 Failure / (18) Sensor Driver Failure / (19) DSP Failure / (20) uProc. Failure / (21) FrontEnd Failure / (26) DM Failure / (27) BM Failure / (28) HW Combination Error / (31) System Error	Uninitialized
FD_EXTENDED_ACTIVE_31 FD_EXTENDED_ACTIVE_31	R	An optional parameter to allow the user finer detail on conditions causing an active condition in the FD_*_ACTIVE parameter. Setting: (31) Crossed Cabling	Uninitialized

Parameter DD name	Access	Description and settings	Initial Value
FD_EXTENDED_MAP_1 FD_EXTENDED_MAP_1	R/W	Field Diagnostics of "Electronics : Operation Info" Setting: (00) Optical Interf. Active / (01) Disp. 2 Overrange / (02) Disp. 1 Overrange / (06) RB is set to OOS / (07) Fieldbus No Connection / (11) Status Out B Active / (13) Status Out A Active / (14) Control In B Active / (15) Control In A Active / (30) Sensor Starting up / (31) Zero Calibr. Running	Uninitialized
FD_EXTENDED_MAP_2 FD_EXTENDED_MAP_2	R	An optional parameter to allow the user finer control on enabling conditions contributing to the conditions in FD_*_ACTIVE parameter. Setting: (20) Disp. 2 no measure values / (21) Dsp. 1 no measure values / (28) IO B No Value for Binary Output / (29) IO B No Value for Current Output / (30) IO A No Value for Binary Output / (31) IO A No Value for Current Output	Uninitialized
FD_EXTENDED_MAP_3 FD_EXTENDED_MAP_3	R	An optional parameter to allow the user finer control on enabling conditions contributing to the conditions in FD_*_ACTIVE parameter. Setting: (00) Reserved	Uninitialized
FD_EXTENDED_MAP_4 FD_EXTENDED_MAP_4	R	An optional parameter to allow the user finer control on enabling conditions contributing to the conditions in FD_*_ACTIVE parameter. Setting: (00) Reserved	Uninitialized
FD_EXTENDED_MAP_5 FD_EXTENDED_MAP_5	R	An optional parameter to allow the user finer control on enabling conditions contributing to the conditions in FD_*_ACTIVE parameter. Setting: (00) Reserved	Uninitialized
FD_EXTENDED_MAP_6 FD_EXTENDED_MAP_6	R	An optional parameter to allow the user finer control on enabling conditions contributing to the conditions in FD_*_ACTIVE parameter. Setting: (00) Reserved	Uninitialized
FD_EXTENDED_MAP_7 FD_EXTENDED_MAP_7	R	An optional parameter to allow the user finer control on enabling conditions contributing to the conditions in FD_*_ACTIVE parameter. Setting: (00) Reserved	Uninitialized
FD_EXTENDED_MAP_8 FD_EXTENDED_MAP_8	R	An optional parameter to allow the user finer control on enabling conditions contributing to the conditions in FD_*_ACTIVE parameter. Setting: (00) Reserved	Uninitialized
FD_EXTENDED_MAP_9 FD_EXTENDED_MAP_9	R	An optional parameter to allow the user finer control on enabling conditions contributing to the conditions in FD_*_ACTIVE parameter. Setting: (00) Reserved	Uninitialized
FD_EXTENDED_MAP_10 FD_EXTENDED_MAP_10	R	An optional parameter to allow the user finer control on enabling conditions contributing to the conditions in FD_*_ACTIVE parameter. Setting: (00) Reserved	Uninitialized

Parameter DD name	Access	Description and settings	Initial Value
FD_EXTENDED_MAP_11 FD_EXTENDED_MAP_11	R/W	Field Diagnostics of "Process : Signal Unreliable" Setting: (28) Time of Flight / (29) Path 3 unreliable / (30) Path 2 unreliable / (31) Path 1 unreliable	Uninitialized
FD_EXTENDED_MAP_12 FD_EXTENDED_MAP_12	R/W	Field Diagnostics of "Process : Signal Lost" Setting: (29) Signal lost path 3 / (30) Signal lost path 2 / (31) Signal lost path 1	Uninitialized
FD_EXTENDED_MAP_13 FD_EXTENDED_MAP_13	R/W	Field Diagnostics of "Process : Empty Pipe" Setting: (31) Empty Pipe	Uninitialized
FD_EXTENDED_MAP_14 FD_EXTENDED_MAP_14	R/W	Field Diagnostics of "Electronics : IO Connection" Setting: (28) IO B Connect. Control Input / (29) IO B Connect. Current In-/Output / (30) IO A Connect. Control Input / (31) IO A Connect. Current In-/Output	Uninitialized
FD_EXTENDED_MAP_15 FD_EXTENDED_MAP_15	R/W	Field Diagnostics of "Process : Current input" Setting: (30) IO B Error Current / (31) IO A Error Current	Uninitialized
FD_EXTENDED_MAP_16 FD_EXTENDED_MAP_16	R	Field Diagnostics of "M Process" Setting: (00) Reserved	Uninitialized
FD_EXTENDED_MAP_17 FD_EXTENDED_MAP_17	R/W	Field Diagnostics of "M Configuration" Setting: (30) Backup 2 Data Faulty / (31) Backup 1 Data Faulty	Uninitialized
FD_EXTENDED_MAP_18 FD_EXTENDED_MAP_18	R/W	Field Diagnostics of "M Electronics" Setting: (29) Backplane Difference / (30) Factory Data Faulty / (31) Backplane Data Faulty	Uninitialized
FD_EXTENDED_MAP_19 FD_EXTENDED_MAP_19	R	Field Diagnostics of "M Sensor" Setting: (00) Reserved	Uninitialized
FD_EXTENDED_MAP_20 FD_EXTENDED_MAP_20	R/W	Field Diagnostics of "S Process" Setting: (31) Velocity Out of Range	Uninitialized
FD_EXTENDED_MAP_21 FD_EXTENDED_MAP_21	R/W	Field Diagnostics of "S Configuration" Setting: (03) IO B Overage Binary Output / (04) IO B Overage Current Output / (05) IO B Overage Current In-/Output / (06) IO A Overage Binary Output / (07) IO A Overage Current Output / (09) IO A Overage Current In-/Output	Uninitialized
FD_EXTENDED_MAP_22 FD_EXTENDED_MAP_22	R/W	Field Diagnostics of "S Electronics" Setting: (29) Conv. Zero too large	Uninitialized
FD_EXTENDED_MAP_23 FD_EXTENDED_MAP_23	R	Field Diagnostics of "S Sensor" Setting: (00) Reserved	Uninitialized

Parameter DD name	Access	Description and settings	Initial Value
FD_EXTENDED_MAP_24 FD_EXTENDED_MAP_24	R	Field Diagnostics of "C Process" Setting: (00) Reserved	Uninitialized
FD_EXTENDED_MAP_25 FD_EXTENDED_MAP_25	R/W	Field Diagnostics of "C Configuration" Setting: (06) IO B Simulation Active / (07) IO B Sim. Binary Output / (08) IO B Sim. Current In-/Output / (09) IO B Sim. Limit Sw./Current Out / (10) IO A Sim. Binary Output / (11) IO A Sim. Current In-/Output / (12) IO A Sim. Limit Sw./Current Out / (30) VoS Simulation Active / (31) Flow Simulation Active	Uninitialized
FD_EXTENDED_MAP_26 FD_EXTENDED_MAP_26	R	Field Diagnostics of "C Electronics" Setting: (00) Reserved	Uninitialized
FD_EXTENDED_MAP_27 FD_EXTENDED_MAP_27	R	Field Diagnostics of "C Sensor" Setting: (00) Reserved	Uninitialized
FD_EXTENDED_MAP_28 FD_EXTENDED_MAP_28	R	Field Diagnostics of "F Process" Setting: (00) Reserved	Uninitialized
FD_EXTENDED_MAP_29 FD_EXTENDED_MAP_29	R/W	Field Diagnostics of "F Configuration" Setting: (02) IO B Binary Output Config / (03) IO B Current In-/Output Config / (04) IO A Binary Output Config / (05) IO A Current In-/Output Config. / (10) IO2 Configuration / (11) IO1 Configuration / (12) Display Config. / (26) Process Input Config. / (30) DM Configuration / (31) BM Configuration	Uninitialized
FD_EXTENDED_MAP_30 FD_EXTENDED_MAP_30	R/W	Field Diagnostics of "F Electronics" Setting: (01) IO B Failure / (02) IO A Failure / (07) IO 2 Failure / (08) IO 1 Failure / (18) Sensor Driver Failure / (19) DSP Failure / (20) uProc. Failure / (21) FrontEnd Failure / (26) DM Failure / (27) BM Failure / (28) HW Combination Error / (31) System Error	Uninitialized
FD_EXTENDED_MAP_31 FD_EXTENDED_MAP_31	R/W	Field Diagnostics of "F Sensor" Setting: (31) Crossed Cabling	Uninitialized
FD_MAINT_ACTIVE Maintenance Active	R	This parameter reflects the error conditions that are being detected as active as selected for this category. It is a bit string, so that multiple conditions may be shown. See section 2.9. Setting: (00) Check / (01) Electronics : Operation Info / (08) Electronics : Power Fail / (10) Configuration : Totaliser / (11) Process : Signal Unreliable / (12) Process : Signal Lost / (13) Process : Empty Pipe / (14) Electronics : IO Connection / (15) Process : Current input / (16) M Process / (17) M Configuration / (18) M Electronics / (19) M Sensor / (20) S Process / (21) S Configuration / (22) S Electronics / (23) S Sensor / (24) C Process / (25) C Configuration / (26) C Electronics / (27) C Sensor / (28) F Process / (29) F Configuration / (30) F Electronics / (31) F Sensor	Uninitialized
FD_MAINT_ALM Fail Maintenance Alarm		This parameter is used primarily to broadcast a change in the associated active conditions, which are not masked, for this alarm category to a Host System.	

Parameter DD name	Access	Description and settings	Initial Value
Unacknowledged	R/W	A discrete enumeration which is set to "Unacknowledged" when an alarm occurs, and set to "Acknowledged" by a write from a human interface device or other entity which can acknowledge that the alarm/event has been noticed. Setting: Uninitialized / Acknowledged / Unacknowledged	Uninitialized
Alarm State	R	A discrete enumeration which gives an indication of whether the alert is active and whether it has been reported. Setting: Uninitialized / Clear - reported / Clear - not reported / Active - reported / Active - not reported	Uninitialized
Time Stamp	R	The time when evaluation of the block was started and a change in alarm/event state was detected that is unreported. The time stamp value will be maintained constant until alert confirmation has been received - even if another change of state occurs. Setting: MM / DD / YY (Month / Day / Year) HH:MM:SS (Hour:Minute:Second)	Uninitialized
Subcode	R	An enumeration specifying the cause of the alert to be reported.	-
Value	R	The value of the associated parameter at the time the alert was detected.	-
FD_MAINT_MAP Maintenance Map	R/W	This parameter enables or disables conditions to be detected as active for this alarm category. Setting: (00) Check / (01) Electronics : Operation Info / (08) Electronics : Power Fail / (10) Configuration : Totaliser / (11) Process : Signal Unreliable / (12) Process : Signal Lost / (13) Process : Empty Pipe / (14) Electronics : IO Connection / (15) Process : Current input / (16) M Process / (17) M Configuration / (18) M Electronics / (19) M Sensor / (20) S Process / (21) S Configuration / (22) S Electronics / (23) S Sensor / (24) C Process / (25) C Configuration / (26) C Electronics / (27) C Sensor / (28) F Process / (29) F Configuration / (30) F Electronics / (31) F Sensor	{16} {17} {18} {19}
FD_MAINT_MASK Maintenance Mask	R/W	This parameter allows the user to suppress any single or multiple conditions that are active, in this category, from being broadcast to the host through the alarm parameter. Setting: (00) Check / (01) Electronics : Operation Info / (08) Electronics : Power Fail / (10) Configuration : Totaliser / (11) Process : Signal Unreliable / (12) Process : Signal Lost / (13) Process : Empty Pipe / (14) Electronics : IO Connection / (15) Process : Current input / (16) M Process / (17) M Configuration / (18) M Electronics / (19) M Sensor / (20) S Process / (21) S Configuration / (22) S Electronics / (23) S Sensor / (24) C Process / (25) C Configuration / (26) C Electronics / (27) C Sensor / (28) F Process / (29) F Configuration / (30) F Electronics / (31) F Sensor	
FD_MAINT_PRI Maintenance Priority	R/W	This parameter allows the user to specify the priority of this alarm category. Setting: 0...15	0

Parameter DD name	Access	Description and settings	Initial Value
FD_OFFSPEC_ACTIVE Offspec Active	R	This parameter reflects the error conditions that are being detected as active as selected for this category. It is a bit string, so that multiple conditions may be shown. See section 2.9. Setting: (00) Check / (01) Electronics : Operation Info / (08) Electronics : Power Fail / (10) Configuration : Totaliser / (11) Process : Signal Unreliable / (12) Process : Signal Lost / (13) Process : Empty Pipe / (14) Electronics : IO Connection / (15) Process : Current input / (16) M Process / (17) M Configuration / (18) M Electronics / (19) M Sensor / (20) S Process / (21) S Configuration / (22) S Electronics / (23) S Sensor / (24) C Process / (25) C Configuration / (26) C Electronics / (27) C Sensor / (28) F Process / (29) F Configuration / (30) F Electronics / (31) F Sensor	Uninitialized
FD_OFFSPEC_ALM Offspec Alarm		This parameter is used primarily to broadcast a change in the associated active conditions, which are not masked, for this alarm category to a Host System.	
Unacknowledged	R/W	A discrete enumeration which is set to "Unacknowledged" when an alarm occurs, and set to "Acknowledged" by a write from a human interface device or other entity which can acknowledge that the alarm/event has been noticed. Setting: Uninitialized / Acknowledged / Unacknowledged	Uninitialized
Alarm State	R	A discrete enumeration which gives an indication of whether the alert is active and whether it has been reported. Setting: Uninitialized / Clear - reported / Clear - not reported / Active - reported / Active - not reported	Uninitialized
Time Stamp	R	The time when evaluation of the block was started and a change in alarm/event state was detected that is unreported. The time stamp value will be maintained constant until alert confirmation has been received - even if another change of state occurs. Setting: MM / DD / YY (Month / Day / Year) HH:MM:SS (Hour:Minute:Second)	Uninitialized
Subcode	R	An enumeration specifying the cause of the alert to be reported.	-
Value	R	The value of the associated parameter at the time the alert was detected.	-
FD_OFFSPEC_MAP Offspec Map	R/W	This parameter enables or disables conditions to be detected as active for this alarm category. Setting: (00) Check / (01) Electronics : Operation Info / (08) Electronics : Power Fail / (10) Configuration : Totaliser / (11) Process : Signal Unreliable / (12) Process : Signal Lost / (13) Process : Empty Pipe / (14) Electronics : IO Connection / (15) Process : Current input / (16) M Process / (17) M Configuration / (18) M Electronics / (19) M Sensor / (20) S Process / (21) S Configuration / (22) S Electronics / (23) S Sensor / (24) C Process / (25) C Configuration / (26) C Electronics / (27) C Sensor / (28) F Process / (29) F Configuration / (30) F Electronics / (31) F Sensor	(20) (21) (22) (23)

Parameter DD name	Access	Description and settings	Initial Value
FD_OFFSPEC_MASK Offspec Mask	R/W	This parameter allows the user to suppress any single or multiple conditions that are active, in this category, from being broadcast to the host through the alarm parameter. Setting: (00) Check / (01) Electronics : Operation Info / (08) Electronics : Power Fail / (10) Configuration : Totaliser / (11) Process : Signal Unreliable / (12) Process : Signal Lost / (13) Process : Empty Pipe / (14) Electronics : IO Connection / (15) Process : Current input / (16) M Process / (17) M Configuration / (18) M Electronics / (19) M Sensor / (20) S Process / (21) S Configuration / (22) S Electronics / (23) S Sensor / (24) C Process / (25) C Configuration / (26) C Electronics / (27) C Sensor / (28) F Process / (29) F Configuration / (30) F Electronics / (31) F Sensor	(11) (12) (13) (14) (20) (21) (22) (23)
FD_OFFSPEC_PRI Offspec Priority	R/W	This parameter allows the user to specify the priority of this alarm category. Setting: 0...15	0
FD_RECOMMEN_ACT	R	This parameter is a device enumerated summarization of the most severe condition or conditions detected. The DD help should describe by enumerated action, what should be done to alleviate the condition or conditions. Setting: (0):Not Initialized / (1):No Action Required / (2):Remove Simulate Jumper! / (1)(01)(00):Keys can be used 60 sec. after removal of optical interface. / (1)(01)(01):Check configuration settings of display line 2. / (1)(01)(02):Check configuration settings of display line 1. / (1)(01)(06): Set MODE_BLK.TARGET at RB to AUTO / (1)(01)(07): Check Fieldbus Terminal and Connection / (1)(01)(11): / (1)(01)(12): / (1)(01)(13): / (1)(01)(14): / (1)(01)(15): / (1)(01)(30):After starting up the converter will respond. / (1)(01)(31):Zero Calibration will stop and normal behavior will follow. / (1)(02)(20): Select another measurement for meas. page 2 / (1)(02)(21): Select another measurement for meas. page 1 / (1)(02)(28): Select another measurement for IO B or activate diagnosis meas. / (1)(02)(29): Select another measurement for IO B or activate diagnosis meas. / (1)(02)(30): Select another measurement for IO A or activate diagnosis meas. / (1)(02)(31): Select another measurement for IO A or activate diagnosis meas. / (1)(03)(00):reserved / (1)(04)(00):reserved / (1)(05)(00):reserved / (1)(06)(00):reserved / (1)(07)(00):reserved / (1)(08)(00):reserved / (1)(09)(00):reserved / (1)(10)(00):reserved / (1)(11)(28):Try to establish a reasonable flow profile or check the fluid / (1)(11)(29):Check the acoustic properties of the medium for this path / (1)(11)(30):Check the acoustic properties of the medium for this path /	Uninitialized

Parameter DD name	Access	Description and settings	Initial Value
		<p>(1)(11)(31):Check the acoustic properties of the medium for this path / (1)(12)(29):Remove the damping or blockage in path 3 in the sensor. / (1)(12)(30):Remove the damping or blockage in path 2 in the sensor. / (1)(12)(31):Remove the damping or blockage in path 1 in the sensor. / (1)(13)(31):Fill the sensor with liquid to return to normal operation. / (1)(14)(28):Check cable and connection at terminal B , reduce load. / (1)(14)(29):Check cable and connection at terminal B , reduce load. / (1)(14)(30):Check cable and connection at terminal A , reduce load. / (1)(14)(31):Check cable and connection at terminal A , reduce load. / (1)(15)(30):Check device connected to current input B. / (1)(15)(31):Check device connected to current input A. / (1)(16)(00):reserved / (1)(17)(30):Save settings to Backup 2. / (1)(17)(31):Save settings to Backup 1. / (1)(18)(29):Change one param. The status should disappear within 1 minute. / (1)(18)(30):Please contact the factory. / (1)(18)(31):Check if converter is correctly mounted and fixed into housing. / (1)(19)(00):reserved / (1)(20)(31):Check process conditions or pipe diameter settings. / (1)(21)(03):Check the range settings of the related output. / (1)(21)(04):Check the range settings of the related output. / (1)(21)(05):Check the range settings of the related output. / (1)(21)(06):Check the range settings of the related output. / (1)(21)(07):Check the range settings of the related output. / (1)(21)(09):Check the range settings of the related output. / (1)(22)(29):Recalibrate FrontEnd of the converter or contact the factory. / (1)(23)(00):reserved / (1)(24)(00):reserved / (1)(25)(06):Turn off simulation / (1)(25)(07):Turn off simulation / (1)(25)(08):Turn off simulation / (1)(25)(09):Turn off simulation / (1)(25)(10):Turn off simulation / (1)(25)(11):Turn off simulation / (1)(25)(12):Turn off simulation / (1)(25)(30):For normal operation turn off simulation mode. / (1)(25)(31):For normal operation turn off simulation mode. / (1)(26)(00):reserved / (1)(27)(00):reserved / (1)(28)(00):reserved / (1)(29)(02):Check IO B configuration or reset to factory configuration. / (1)(29)(03):Check IO B configuration or reset to factory configuration. / (1)(29)(04):Check IO A configuration or reset to factory configuration. / (1)(29)(05):Check IO A configuration or reset to factory configuration. / (1)(29)(10):Check IO2 configuration or reset to factory configuration. / (1)(29)(11):Check IO1 configuration or reset to factory configuration. / (1)(29)(12):Check display configuration or reset to factory configuration. / (1)(29)(21): Check fieldbus configuration or reset to factory configuration / (1)(29)(26):Check config. of the related function. Reset config. to factory. / (1)(29)(30):Check config. of the related function. Reset config. to factory. / (1)(29)(31):Check config. of the related function. Reset config. to factory. / (1)(30)(01):Perform power reset. If the status returns , contact the factory. / (1)(30)(02):Perform power reset. If the status returns , contact the factory. / (1)(30)(07):Perform power reset. If the status returns , contact the factory. / (1)(30)(08):Perform power reset. If the status returns , contact the factory. / (1)(30)(16):Perform power reset. If the status returns , contact the factory. / (1)(30)(18):Perform power reset. If the status returns , contact the factory. / (1)(30)(19):Perform power reset. If the status returns , contact the factory. / (1)(30)(20):Perform power reset. If the status returns , contact the factory. / (1)(30)(21):Perform power reset. If the status returns , contact the factory. / (1)(30)(26):Perform power reset. If the status returns , contact the factory. / (1)(30)(27):Perform power reset. If the status returns , contact the factory. / (1)(30)(28):Perform power reset. If the status returns , contact the factory. / (1)(30)(31):Perform power reset. If the status returns , contact the factory. / (1)(31)(31):Check manual for transducer cabling in case of a remote device.</p>	

Parameter DD name	Access	Description and settings	Initial Value
FD_SIMULATE Field Diagnostic Simulate		Used as the field diagnostic condition when the simulation is enabled.	-
DIAGNOSTIC_SIMULATE_VALUE Diagnostic Simulate Value	R/W	Allows the conditions to be manually supplied when simulation is enabled. The simulate jumper is required for simulation to be enabled. Setting: (00) Check / (01) Electronics : Operation Info / (08) Electronics : Power Fail / (10) Configuration : Totaliser / (11) Process : Signal Unreliable / (12) Process : Signal Lost / (13) Process : Empty Pipe / (14) Electronics : IO Connection / (15) Process : Current input / (16) M Process / (17) M Configuration / (18) M Electronics / (19) M Sensor / (20) S Process / (21) S Configuration / (22) S Electronics / (23) S Sensor / (24) C Process / (25) C Configuration / (26) C Electronics / (27) C Sensor / (28) F Process / (29) F Configuration / (30) F Electronics / (31) F Sensor	Uninitialized
DIAGNOSTIC_VALUE Diagnostic Value	R	Current field diagnostic condition. Setting: (00) Check / (01) Electronics : Operation Info / (08) Electronics : Power Fail / (10) Configuration : Totaliser / (11) Process : Signal Unreliable / (12) Process : Signal Lost / (13) Process : Empty Pipe / (14) Electronics : IO Connection / (15) Process : Current input / (16) M Process / (17) M Configuration / (18) M Electronics / (19) M Sensor / (20) S Process / (21) S Configuration / (22) S Electronics / (23) S Sensor / (24) C Process / (25) C Configuration / (26) C Electronics / (27) C Sensor / (28) F Process / (29) F Configuration / (30) F Electronics / (31) F Sensor	Uninitialized
ENABLE_DISABLE Simulate En/Disable	R/W	Enable/disable simulation. Setting: Uninitialized / Disabled / Active	Uninitialized
FD_VER Revision	R	The major version of the Field Diagnostics specification used for the development of this device.	1
FEATURES Features	R	Used to shows supported resource block options. Setting: Reports / Soft W Lock / MVC Report Distribution supported / MVC Publishing/Subscribing supported / Multi-bit Alarm (Bit- Alarm) Support	Reports Soft W Lock MVC Report Distribution supported MVC Publishing/ Subscribing supported Multi-bit Alarm (Bit-Alarm) Support
FEATURES_SEL Features Selection	R/W	Used to select resource block options. Setting: Reports / Soft W Lock / MVC Report Distribution supported / MVC Publishing/Subscribing supported / Multi-bit Alarm (Bit- Alarm) Support	Reports Soft W Lock
FREE_SPACE Free Space	R	Percent of the memory available for further configuration. Zero in a preconfigured resource. Setting: 0.0...100.0	0.0
FREE_TIME Free Time	R	Percent of the block processing time that is free to process additional blocks. Setting: 0.0...100.0	0.0

Parameter DD name	Access	Description and settings	Initial Value
GRANT_DENY Grant Deny	R/W	Options for controlling access of host computers and local control panels to operating, tuning and alarm parameters of the block.	-
GRANT Grant	R/W	Depending on the philosophy of the plant, the operator or a higher level device (HLD) or a local operator's panel (LOP) in the case of "Local", may turn on an item of the "Grant" attribute - "Program, Tune, Alarm or Local". Setting: Program / Tune / Alarm / Local / Operate	Uninitialized
DENY Deny	R/W	The Denied attribute is limited for use by a monitoring application in an interface device and may not be changed by an operator. Setting: Program denied / Tune denied / Alarm denied / Local denied / Operate denied	Uninitialized
HARD_TYPES Hardware Types	R	The types of hardware available as channel numbers.	Scalar input
ITK_VER ITK Version (Interoperability Test Kit)	R	Major revision number of the interoperability test case used to register this device.	5
LIM_NOTIFY Limit Notify	R/W	Maximum number of unconfirmed alert notify messages allowed. Setting: 0...255	20
MANUFAC_ID Manufacturer ID	R	Manufacturer identification number - used by an interface device to locate the DD file for the resource. Setting: KROHNE	KROHNE
MAX_NOTIFY Maximum Notify	R	Maximum number of unconfirmed alert notify messages possible. Setting: 0...255	20
MEMORY_SIZE Memory Size	R	Available configuration memory in the empty resource. To be checked before attempting a download.	0
MIN_CYCLE_T Minimum Cycle Time	R	Time duration of the shortest cycle interval of which the resource is capable (in [1/32 ms]).	6400
NV_CYCLE_T Nonvolatile Cycle Time	R	Interval between writing copies of NV parameters to non-volatile memory. Zero means never (in [1/32 ms]).	256000
RESTART Restart	R/W	Allows a manual restart to be initiated. Several degrees of restart are possible. They are 1: Run, 2: Restart resource, 3: Restart with defaults and 4: Restart processor. Setting: Uninitialized / Run / Resource / Defaults / Processor	Run
RS_STATE Resource State	R	State of the function block application state machine. Setting: Uninitialized / Start_Restart / Initialization / Online Linking / Online / Standby / Failure	Standby
SET_FSTATE Set Fault State	R/W	Allows the fault state condition to be manually initiated by selecting "Set". Setting: Off	Off

Parameter DD name	Access	Description and settings	Initial Value
SHED_RCAS Shed Remote Cascade	R/W	Time duration at which to give up on computer writes to function block RCAS locations.	640000
		Setting: 0...4294967295 in [1/32 ms]	
SHED_ROUT Shed Remote Out	R/W	Time duration at which to give up on computer writes to function block ROUT locations.	640000
		Setting: 0...4294967295 in [1/32 ms]	
TEST_RW Test R Write		Read/write test parameter - used only for conformance testing. Note: Subelements "1..15" have no function!	-
UPDATE_EVT Update Event		This alert is generated by any change to the static data.	-
Unacknowledged	R/W	A discrete enumeration which is set to "Unacknowledged" when an update occurs, and set to "Acknowledged" by a write from a human interface device or other entity which can acknowledge that the alarm/event has been noticed.	Uninitialized
		Setting: Uninitialized / Acknowledged / Unacknowledged	
Update State	R	A discrete enumeration which gives an indication of whether the alert has been reported.	Uninitialized
		Setting: Uninitialized / Reported / Not reported	
Time Stamp	R	The time when evaluation of the block was started and a change in alarm/event state was detected that is unreported. The time stamp value will be maintained constant until alert confirmation has been received - even if another change of state occurs.	Uninitialized
		Setting: MM / DD / YY (Month / Day / Year) HH:MM:SS (Hour:Minute:Second)	
Static Revision	R	The static revision of the block whose static parameter was changed and is being reported. It is possible for the present value of static revision to be greater than this because static can be changed at any time.	0
		Setting: 0...65535	
Relative Index	R	The OD index of the static parameter whose change caused this alert, minus the FB starting index. If the update event was caused by a write to multiple parameters at the same time, then this attribute will be zero.	0
		Setting: 0...65535	
WRITE_ALM Write Alarm	Mix	This alert is generated if the write lock parameter is cleared.	-
Unacknowledged	R/W	A discrete enumeration which is set to "Unacknowledged" when an alarm occurs, and set to "Acknowledged" by a write from a human interface device or other entity which can acknowledge that the alarm/event has been noticed.	Uninitialized
		Setting: Uninitialized / Acknowledged / Unacknowledged	
Alarm State	R	A discrete enumeration which gives an indication of whether the alert is active and whether it has been reported.	Uninitialized
		Setting: Uninitialized / Clear - reported / Clear - not reported / Active - reported / Active - not reported	

Parameter DD name	Access	Description and settings	Initial Value
Time Stamp	R	The time when evaluation of the block was started and a change in alarm/event state was detected that is unreported. The time stamp value will be maintained constant until alert confirmation has been received - even if another change of state occurs. Setting: MM / DD / YY (Month / Day / Year) HH:MM:SS (Hour:Minute:Second)	Uninitialized
Subcode	R	An enumeration specifying the cause of the alert to be reported. Setting: Other / Block Configuration / Link Configuration / Simulation Active / Local Override / Device Fault State / Device Maintenance / Input Failure / Output Failure / Memory Failure / Lost Static Data / Lost NV Data / Readback Check / Maintenance Needed / Power Up / Out Of Service	Other
Discrete Value	R	The value of the associated parameter at the time the alert was detected. Setting: Discrete State 0...16	State 0
WRITE_LOCK Write Lock	R/W	If set, no writes from anywhere are allowed, except to clear WRITE_LOCK. Block inputs will continue to be updated. Setting: Uninitialized / Not locked / Locked	Not locked
WRITE_PRI Write Priority	R	Priority of the alarm generated by clearing the write lock. Setting: 0...15	0
DIAGNOSIS Diagnosis	R	Detailed diagnosis of the device.	-
MEMORY_SUMMARY Memory Summary	R	Summary of self diagnosis. Setting: Task Control / RAM int / RAM ext / ROM boot area / ROM application / FLASH / FRAM / EEPROM / bit08 / bit09 / bit10 / bit11 / bit12 / bit13 / bit14 / bit15	Uninitialized
FRAM_DIAG FRAM Diagnosis	R	Result of FRAM self diagnosis. Setting: ok , page high / warning : one header / warning : write cycles / warning : uncertain / warning : inconsistent / write error / chip error / page error / parameter error / bit09 / changed / first init / wait / busy / unknown / not supported action	Uninitialized
workLOAD	R	Work load of the processor.	0
EMPTY_PIPE Status Empty Pipe	R/W	Defines the influence of the diagnostic "Process : Empty Pipe" (FD_xx_13) to the TB measurements status (Fct. C1.10.3). Setting: Information / Maintenance Required / Checks in progress / Out Of Specification / Failure	Information
FORMAT_2P_1L Form. 2.Page 1.Line	R/W	No. of decimal places for 1st line of 2nd page (Fct. C5.4.2). Setting: #X. / #X.X / #X.XX / #X.XXX / #X.XXXX / #X.XXXXX / #X.XXXXXX / #X.XXXXXXX / #X.XXXXXXX / #X.XXXXXXX / automatic	X.X

Parameter DD name	Access	Description and settings	Initial Value
FORMAT_2P_2L Form. 2.Page 2.Line	R/W	No. of decimal places for 2st line of 2nd page (Fct. C5.4.4).	X.X
		Setting: #X. / #X.X / #X.XX / #X.XXX / #X.XXXX / #X.XXXXX / #X.XXXXXX / #X.XXXXXX / #X.XXXXXXX / automatic	
FORMAT_2P_3L Form. 2.Page 3.Line	R/W	No. of decimal places for 3st line of 2nd page (Fct. C5.4.5).	X.X
		Setting: #X. / #X.X / #X.XX / #X.XXX / #X.XXXX / #X.XXXXX / #X.XXXXXX / #X.XXXXXX / #X.XXXXXXX / automatic	
IO_CONNECTION Status IO Connection	R/W	Defines the influence of the diagnostic "Electronic : IO Connection" (FD_xx_14) to the TB measurements status (Fct. C1.10.7).	Information
		Setting: Information / Maintenance Required / Checks in progress / Out Of Specification / Failure	
PASSWRD Password	R/W	Password to activate access rights to restricted parameters.	0
POWER_FAILURE Status Power Failure	R/W	Defines the influence of the diagnostic "Electronic : Power Failure" (FD_xx_8) to the TB measurements status (Fct. C1.10.8).	Information
		Setting: Information / Maintenance Required / Checks in progress / Out Of Specification / Failure	
PROTECT_INFO Access protection	R	Current protection level to restricted parameters.	Production
		Setting: Concentration / bit 5...6: not use / User / Service level / Production / Custody Transfer / Write Lock	
SERIAL_NUMBER Serial Number	R	Device serial number, serial number of the system.	Current serial number
SIGNAL_LOST Status Signal Lost	R/W	Defines the influence of the diagnostic "Process : Signal Lost" (FD_xx_12) to the TB measurements status (Fct. C1.10.4).	Information
		Setting: Information / Maintenance Required / Checks in progress / Out Of Specification / Failure	
SIGNAL_UNRELIABLE Status Signal Unreliable	R/W	Defines the influence of the diagnostic "Process : Signal Unreliable" (FD_xx_11) to the TB measurements status (Fct. C1.10.5).	Information
		Setting: Information / Maintenance Required / Checks in progress / Out Of Specification / Failure	
SW_SIMULATE SW simulate	R/W	Enable/disable simulation like simulate Hardware jumper.	Disable
		Setting: Disable / Active	
Variable_2P_1L Disp. 2.Page 1.Line	R/W	Select the Function Block output value to display at 2nd page 1st line (Fct. C5.4.1).	AI1
		Setting: AI10 / AI2 / AI3 / AI4 / PID / IT1 / IT2	
Variable_2P_2L Disp. 2.Page 2.Line	R/W	Select the Function Block output value to display at 2nd page 2nd line (Fct. C5.4.3).	AI1
		Setting: AI10 / AI2 / AI3 / AI4 / PID / IT1 / IT2	

Parameter DD name	Access	Description and settings	Initial Value
Variable_2P_3L Disp. 2.Page 3.Line	R/W	Select the Function Block output value to display at 2nd page 3rd line (Fct. C5.4.5).	AI1
		Setting: AI10 / AI2 / AI3 / AI4 / PID / IT1 / IT2	

4.5 Analog Input Block (AI 1...4)

The following tables list the Analog Input Block parameters in alphabetical order.

It describes characteristics of the measurement values obtained from the Transducer Block in a user defined way and to deliver it to the control system. There are also some parameters in the Analog Input Block, that can be configured to get a measurement value quality as desired by the user.

The following tables contain short parameter description, factory settings (Initial Value (IV)) and possible settings.

Parameter DD name	Access	Description and settings	Initial Value
ALERT_KEY Alert Key	R/W	The identification number of the plant unit. This information may be used in the host for sorting alarms, etc.	0
		Setting: 1...255	
BLOCK_ERR Block Error	R	This parameter reflects the error status associated with the hardware or software components associated with a block. It is a bit string, so that multiple errors may be shown.	Other
		Setting: <ul style="list-style-type: none"> • Other: Non-specific error active • Block Configuration: Error detected in block configuration • Link Configuration: Error detected in link configuration • Simulation Active: Simulation enabled in this block • Local Override: Output tracking of faultstate active • Device Fault State: Device faultstate set • Device Maintenance: Device needs maintenance soon • Input Failure: Process variable has bad status • Output Failure: Failure detected in output hardware • Memory Failure: Memory error detected • Lost Static Data: Static parameters cannot be recovered • Lost NV Data: Non-volatile parameters cannot be recovered • Readback Check: Failure detected in READBACK • Maintenance Needed: Device NEEDS maintenance NOW • Power Up: Recovery from power failure • Out Of Service: Block actual mode is out of service 	
MODE_BLK Block Mode	Mix	The actual, target, permitted and normal modes of the block.	-
TARGET Target	R/W	This is the mode requested by the operator. Only one mode from those allowed by the permitted mode parameter may be requested.	OOS
		Setting: Auto / Manual / OOS	

Parameter DD name	Access	Description and settings	Initial Value
ACTUAL Actual	R	This is the current mode of the block, which may differ from the target based on operating conditions. Its value is calculated as part of block execution.	OOS
		Setting: Auto / Manual / OOS	
PERMITTED Permitted	R/W	Defines the modes which are allowed for an instance in the block. The permitted mode is configured based on application requirements.	Auto OOS
		Setting: Auto / Manual / OOS	
NORMAL Normal	R/W	This is the mode which the block should be set to during normal operating conditions.	Auto
		Setting: Auto / Manual / OOS	
ST_REV Static Revision	R	The revision level of the static data associated with the function block. The revision value will be incremented each time a static parameter value in the block is changed.	0
		Setting: 0...65535	
STRATEGY Strategy	R/W	The strategy field can be used to identify grouping of blocks. This data is not checked or processed by the block.	0
		Setting: 0...65535	
TAG_DESC Tag Description	R/W	This is the user description of the intended application of the block.	blanks
		Setting: ≤32 digits	
ACK_OPTION Acknowledge Option	R/W	Selection of whether alarms associated with the function block will be automatically acknowledged.	Uninitialized
		Setting: HiHi Alm Auto Ack / Hi Alm Auto Ack / LoLo Alm Auto Ack / Lo Alm Auto Ack / Blk Alm Auto Ack / Fail Alm Auto Ack / Off Spec Alm Auto Ack / Maint Alm Auto Ack / Check Alm Auto Ack	
ALARM_HYS Alarm Hysteresis	R/W	Amount the PV must return within the alarm limits before the alarm condition clears. Alarm hysteresis is expressed as a percent of the PV span.	0.5
		Setting: 0...50%	
ALARM_SUM Alarm Summary	Mix	The current alert status, unacknowledged states, unreported states and disabled states of the alarms associated with the function block.	-
Current	R	The active status of each alarm.	Uninitialized
		Setting: HiHi Alarm / Hi Alarm / LoLo Alarm / Lo Alarm / Block Alarm	
Unacknowledged	R	The unacknowledged state of each alarm.	Uninitialized
		Setting: HiHi Alarm Unack / Hi Alarm Unack / LoLo Alarm Unack / Lo Alarm Unack / Block Alarm Unack	
Unreported	R	The unreported states of each alarm.	Uninitialized
		Setting: HiHi Alarm Unrep / Hi Alarm Unrep / LoLo Alarm Unrep / Lo Alarm Unrep / Block Alarm Unrep	

Parameter DD name	Access	Description and settings	Initial Value
Disabled	R	The disabled state of each alarm Setting: HiHi Alarm Disabled / Hi Alarm Disabled / LoLo Alarm Disabled / Lo Alarm Disabled / Block Alarm Disabled	Uninitialized
BLOCK_ALM Block Alarm	Mix	The block alarm is used for all configuration, hardware, connection failure or system problems in the block. The cause of the alert is entered in the subcode field. The first alert to become active will set the "Active" status in the "Status" attribute. As soon as the "Unreported" status is cleared by the alert reporting task, another block alert may be reported without clearing the "Active" status, if the subcode has changed.	-
Unacknowledged	R/W	A discrete enumeration which is set to "Unacknowledged" when an alarm occurs, and set to "Acknowledged" by a write from a human interface device or other entity which can acknowledge that the alarm/event has been noticed. Setting: Uninitialized / Acknowledged / Unacknowledged	Uninitialized
Alarm State	R	A discrete enumeration which gives an indication of whether the alert is active and whether it has been reported. Setting: Uninitialized / Clear - reported / Clear - not reported / Active - reported / Active - not reported	Uninitialized
Time Stamp	R	The time when evaluation of the block was started and a change in alarm/event state was detected that is unreported. The time stamp value will be maintained constant until alert confirmation has been received - even if another change of state occurs. Setting: MM / DD / YY (Month / Day / Year) HH:MM:SS (Hour:Minute:Second)	Uninitialized
Subcode	R	An enumeration specifying the cause of the alert to be reported. Setting: Other / Block Configuration / Link Configuration / Simulation Active / Local Override / Device Fault State / Device Maintenance / Input Failure / Output Failure / Memory Failure / Lost Static Data / Lost NV Data / Readback Check / Maintenance Needed / Power Up / Out Of Service	Other
Value	R	The value of the associated parameter at the time the alert was detected. Setting: 0...255	0
CHANNEL Channel	R/W	The number of the logical hardware channel that is connected to this I/O block. This information defines the transducer to be used going to or from the physical world. Note: W = Writeable only by setting "00S" in MODE_BLK Setting: 0 Uninitialized 1 Volume Flow 2 Mass Flow 3 Flow Velocity 4 Velocity of Sound 5 Gain 6 SNR 7 Electronic Temperature	Uninitialized

Parameter DD name	Access	Description and settings	Initial Value
FIELD_VAL Field Value	R	Raw value of the field device in percent of the PV range, with a status reflecting the transducer condition, before signal characterization (L_TYPE) or filtering (PV_FTIME).	-
Status	R	Digital transducers, unlike their analogue versions, can detect faults that make the measurement bad or prevent the actuator from responding. This additional, valuable information will be passed along with each transmission of a data value in the form of a status attribute.	Bad Non Specific Not Limited
Value	R	A numerical quantity entered by a user or calculated by the algorithm.	0.0
GRANT_DENY Grant Deny		Options for controlling access of host computers and local control panels to operating, tuning and alarm parameters of the block.	-
GRANT Grant	R/W	Depending on the philosophy of the plant, the operator or a higher level device (HLD) or a local operator's panel (LOP) in the case of "Local", may turn on an item of the "Grant" attribute - "Program, Tune, Alarm or Local". Setting: Program / Tune / Alarm / Local / Operate	Uninitialized
DENY Deny	R/W	The deny attribute is provided for use by a monitoring application in an interface device and may not be changed by an operator. Setting: Program denied / Tune denied / Alarm denied / Local denied / Operate denied	Uninitialized
HI_ALM High Alarm		The status for High Alarm and its associated time stamp. Settings of 5 subelements see in the following part.	-
HI_HI_ALM High High Alarm	Mix	The status for High High Alarm and its associated time stamp. Settings of 5 subelements see in the following part.	-
Settings of 5 subelements for previous 2 parameters High Alarm and High High Alarm:			
Unacknowledged	R/W	Setting: Uninitialized / Acknowledged / Unacknowledged	Uninitialized
Alarm State	R	Setting: Uninitialized / Clear - reported / Clear - not reported / Active - reported / Active - not reported	Uninitialized
Time Stamp	R	Setting: MM / DD / YY (Month / Day / Year) HH:MM:SS (Hour:Minute:Second)	Uninitialized
Subcode	R	Setting: Other / Block Configuration / Link Configuration / Simulation Active / Local Override / Device Fault State / Device Maintenance / Input Failure / Output Failure / Memory Failure / Lost Static Data / Lost NV Data / Readback Check / Maintenance Needed / Power Up / Out Of Service	Other
VALUE Float Value	R	A numerical quantity entered by a user or calculated by the algorithm.	0.0
HI_HI_LIM High High Limit	R/W	The setting for High High Alarm in engineering units. Setting range see in the following part.	NaN
HI_HI_PRI High High Priority	R/W	Priority of the High High Alarm. Setting see in the following part.	0
HI_LIM High Limit	R/W	The setting for High Alarm in engineering units. Setting range see in the following part.	NaN
HI_PRI High Priority	R/W	Priority of the High Alarm. Setting see in the following part.	0

Parameter DD name	Access	Description and settings	Initial Value
Setting range for previous 2 parameters: x_y_LIM x_y_Limit		-3.39 E38...+3.39 E38 / - INF (- infinite) / + INF (+ infinite)	
Setting for previous 2 parameters: x_y_PRI x_y_Priority		0: The associated alert may clear when the priority is changed to 0, but it will never occur. 1: The associated alert is not send as a notification. If the priority is above 1, then the alert must be reported. 2: Reserved for alerts that do not require the attention of a plant operator, e.g. diagnostic and system alerts. Block alarm, error alarm and update event have a fixed priority of 2. 3...7: Increasing higher priorities - advisory alarms. 8...15: Increasing higher priorities - critical alarms.	0
IO_OPTS IO Options (IO = Input/Output)	R/W	Options which the user may select to alter input and output block processing. Setting: Low Cutoff / Units Conversion	Uninitialized
L_TYPE Linearization Type	R/W	Determines if the values passed by the TB to the AI block may be used directly (Direct) or if the value is in different units and must be converted linearly (Indirect) or with square root (Ind Sqr Root), using the input range defined by the transducer and the associated output range. W = Writeable only by setting "OOS" in MODE_BLK Setting: Uninitialized / Direct / Indirect / Ind Sqr Root	Uninitialized
LO_ALM Low Alarm		The status for Low Alarm and its associated time stamp. Settings of 5 subelements see in the following part.	-
LO_LO_ALM Low Low Alarm		The status for Low Low Alarm and its associated time stamp. Settings of 5 subelements see in the following part.	-
Settings of 5 subelements for previous 2 parameters Low Alarm and Low Low Alarm:			
Unacknowledged	R/W	Setting: Uninitialized / Acknowledged / Unacknowledged	Uninitialized
Alarm State	R	Setting: Uninitialized / Clear - reported / Clear - not reported / Active - reported / Active - not reported	Uninitialized
Time Stamp	R	Setting: MM / DD / YY (Month / Day / Year) HH:MM:SS (Hour:Minute:Second)	Uninitialized
Subcode	R	An enumeration specifying the cause of the alert to be reported. Setting: Other / Block Configuration / Link Configuration / Simulation Active / Local Override / Device Fault State / Device Maintenance / Input Failure / Output Failure / Memory Failure / Lost Static Data / Lost NV Data / Readback Check / Maintenance Needed / Power Up / Out Of Service	Other
VALUE Float Value	R	A numerical quantity entered by a user or calculated by the algorithm.	0.0
LO_LIM Low Limit	R/W	The setting for Low Alarm in engineering units. Setting range see in the following part.	(-NaN)
LO_LO_LIM Low Low Limit	R/W	The setting for Low Low Alarm in engineering units. Setting range see in the following part.	(-NaN)
LO_PRI Low Priority	R/W	Priority of the Low Alarm. Setting see in the following part.	0
LO_LO_PRI Low Low Priority	R/W	Priority of the Low Low Alarm. Setting see in the following part.	0

Parameter DD name	Access	Description and settings	Initial Value
Setting range for previous 2 parameters: x_y_LIM x_y_Limit		-3.39 E38...+3.39 E38 / - INF (- infinite) / + INF (+ infinite)	
Setting for previous 2 parameters: x_y_PRI x_y_Priority		0: The associated alert may clear when the priority is changed to 0, but it will never occur. 1: The associated alert is not send as a notification. If the priority is above 1, then the alert must be reported. 2: Reserved for alerts that do not require the attention of a plant operator, e.g. diagnostic and system alerts. Block alarm, error alarm and update event have a fixed priority of 2. 3...7: Increasing higher priorities - advisory alarms. 8...15: Increasing higher priorities - critical alarms.	0
LOW_CUT Low Cutoff	R/W	Limit used in square root processing. A value of zero percent of scale is used in block processing if the transducer value falls below this limit, in %of scale. This feature may be used to eliminate noise near zero for a flow sensor. Setting: ≥0.0	0
OUT Output	R/W	The primary analogue discrete value calculated as a result of executing the function. Note: W = Writeable only by setting "OOS" in MODE_BLK	-
Status	R	Digital transducers, unlike their analogue versions, can detect faults that make the measurement bad or prevent the actuator from responding. This additional, valuable information will be passed along with each transmission of a data value in the form of a status attribute.	-
Value	R/W	A numerical quantity entered by a user or calculated by the algorithm.	-
OUT_SCALE Output Scale	R/W	The high and low scale values, engineering units code and number of digits to the right of the decimal point to be used in displaying the OUT parameter and parameters which have the same scaling as OUT.	-
EU_100 EU at 100%	R/W	The engineering unit value which represents the upper end of range of the associated block parameter.	100.0
EU_0 EU at 0%	R/W	The engineering unit value which represents the lower end of range of the associated block parameter.	0.0
UNITS_INDEX Units Index	R/W	Device Description units code index for the engineering unit descriptor for the associated block value. Setting: All units are possible.	Uninitialized
DECIMAL Decimal	R/W	The number of digits to the right of the decimal point which should be used by an interface device in displaying the specified parameter.	0
PV Process Value		Either the primary analogue value for use in executing the function or a process value associated with it.	-
Status	R	Digital transducers, unlike their analogue versions, can detect faults that make the measurement bad or prevent the actuator from responding. This additional, valuable information will be passed along with each transmission of a data value in the form of a status attribute.	0
Value	R	A numerical quantity entered by a user or calculated by the algorithm.	0.0
PV_FTIME PV F Time (Process Value Filter Time)	R/W	Time constant of a single exponential filter for the PV, in seconds. Setting: 0.0...60.0	0

Parameter DD name	Access	Description and settings	Initial Value
SIMULATE Simulate	Mix	Allows the transducer analogue input or output to the block to be manually supplied when "Simulate" is enabled. When simulation is disabled, the simulate value and status track the actual value and status.	-
Simulate Status	R/W	Used for the transducer status when simulation is enabled.	0
Simulate Value	R/W	Used for the transducer value when simulation is enabled. Setting: -3.39 E38 ... +3.39 E38, - INF, + INF	0.0
Transducer Status	R	Status of value supplied by transducer.	0
Transducer Value	R	Current value supplied by transducer.	0.0
Simulate En/Disable	R/W	The parameter "SW_Simulated" in RB Block must be enabled. Setting: Uninitialized / Disabled / Active	Disabled
STATUS_OPTS Status Option	R/W	Options which the user may select in the block processing of status. Setting: Propagate Fault Forward / Uncertain if limited / BAD if limited / Uncertain if Man.	Uninitialized
UPDATE_EVT Update Event		This alert is generated by any change to the static data.	-
Unacknowledged	RW	A discrete enumeration which is set to "Unacknowledged" when an alarm occurs, and set to "Acknowledged" by a write from a human interface device or other entity which can acknowledge that the alarm/event has been noticed. Setting: Uninitialized / Acknowledged / Unacknowledged	Uninitialized
Update State	R	A discrete enumeration which gives an indication of whether the alert has been reported. Setting: Uninitialized / Reported / Not Reported	Uninitialized
Time Stamp	R	The time when evaluation of the block was started and a change in alarm/event state was detected that is unreported. The time stamp value will be maintained constant until alert confirmation has been received - even if another change of state occurs. Time stamp records the time when parameter was updated. Setting: MM / DD / YY (Month / Day / Year) HH:MM:SS (Hour:Minute:Second)	Uninitialized
Static Revision	R	The static revision of the block whose static parameter was changed and is being reported. It is possible for the present value of static revision to be greater than this because static can be changed at any time.	0
Relative Index	R	The OD index of the static parameter whose change caused this alert, minus the FB starting index. If the update event was caused by a write to multiple parameters at the same time, then this attribute will be zero.	0
XD_SCALE Transducer Scale	R/W	The high and low scale values, engineering units code and number of digits to the right of the decimal point used with the value obtained from the transducer for a specified channel. Note: W = Writeable only by setting "00S" in MODE_BLK	-
EU_100 EU at 100%	R/W	The engineering unit value which represents the upper end of range of the associated block parameter.	100

Parameter DD name	Access	Description and settings	Initial Value
EU_0 EU at 0%	R/W	The engineering unit value which represents the lower end of range of the associated block parameter.	0.0
UNITS_INDEX Units Index	R/W	<p>Device Description units code index for the engineering unit descriptor for the associated block value.</p> <p>Temperature units: K; °C; °F</p> <p>Mass flow units: kg/s; kg/min; kg/h; kg/d; t/s; t/min; t/h; t/d;g/s; g/min; g/h; g/d; lb/s; lb/min; lb/h; lb/d; klb(US)/s; klb(US)/min; klb(US)/h; klb(US)/d; st/s = (Ston/s); st/min = (Ston/min); st/h = (Ston/h); st/d = (Ston/d); lt/s = (LTon/s); lt/min = (Lton/min); lt/h = (LTon/h); lt/d = (LTon/d); MLB/H</p> <p>Volume flow units: m³/s; m³/min; m³/h; m³/d; L/s; L/min; L/h; L/d; kL/s; kL/min; kL/h; kL/d; mL/min; CFS; CFM; CFH; ft³/d; kCFS; kCFM; kCFH; kft³/d; gal/s; GPM; gal/h; gal/d; bbl/s; bbl/min; bbl/h; bbl/d; ImpGal/s; ImpGal/min; ImpGal/h; ImpGal/d</p> <p>Speed (velocity) units: m/s; mm/s; m/h; km/h; in/s; ft/s; yd/s; in/min; ft/min; yd/min; in/h; ft/h; yd/h</p> <p>Gain, SNR units: dB</p>	Depends on the type, the device is calibrated for
DECIMAL Decimal	R/W	The number of digits to the right of the decimal point which should be used by an interface device in displaying the specified parameter.	0

4.6 FLOWTB (Flow Transducer Block)

Parameter DD name	Access	Description and settings	Initial Value
ALERT_KEY Alert Key	R/W	The identification number of the plant unit. This information may be used in the host for sorting alarms, etc. Setting: 1...255	0
BLOCK_ERR Block Error	R	This parameter reflects the error status associated with the hardware or software components associated with a block. It is a bit string, so that multiple errors may be shown. Setting: <ul style="list-style-type: none"> • Other: Non-specific error active • Block Configuration: Error detected in block configuration • Link Configuration: Error detected in link configuration • Simulation Active: Simulation enabled in this block • Local Override: Output tracking of faultstate active • Device Fault State: Device faultstate set • Device Maintenance: Device needs maintenance soon • Input Failure: Process variable has bad status • Output Failure: Failure detected in output hardware • Memory Failure: Memory error detected • Lost Static Data: Static parameters cannot be recovered • Lost NV Data: Non-volatile parameters cannot be recovered • Readback Check: Failure detected in READBACK • Maintenance Needed: Device NEEDS maintenance NOW • Power Up: Recovery from power failure • Out Of Service: Block actual mode is out of service 	Other
MODE_BLK Block Mode		The actual, target, permitted and normal modes of the block.	-
TARGET Target	R/W	This is the mode requested by the operator. Only one mode from those allowed by the permitted mode parameter may be requested. Setting: Auto / OOS	Auto
ACTUAL Actual	R	This is the current mode of the block, which may differ from the target based on operating conditions. Its value is calculated as part of block execution. Setting: Auto / OOS	Auto
PERMITTED Permitted	R/W	Defines the modes which are allowed for an instance of the block. The permitted mode is configured based on application requirement. Setting: Auto / OOS	Auto OOS
NORMAL Normal	R/W	This is the mode which the block should be set to during normal operating conditions. Setting: Auto / OOS	Auto
ST_Rev Static Revision	R	The revision level of the static data associated with the function block. The revision value will be incremented each time a static parameter value in the block is changed. Setting: 0...65535	0

Parameter DD name	Access	Description and settings	Initial Value
STRATEGY Strategy	R/W	The strategy field can be used to identify grouping of blocks. This data is not checked or processed by the block. Setting: 0...65535	0
TAG_DESC Tag Description	R/W	The user description of the intended application of the block. Setting: ≤32 digits	blanks
BLOCK_ALM Block Alarm		The block alarm is used for all configuration, hardware, connection failure or system problems in the block. The cause of the alert is entered in the subcode field. The first alert to become active will set the "Active" status in the "Status" attribute. As soon as the "Unreported" status is cleared by the alert reporting task, another block alert may be reported without clearing the "Active" status, if the subcode has changed.	-
Unacknowledged	R/W	A discrete enumeration which is set to "Unacknowledged" when an alarm occurs, and set to "Acknowledged" by a write from a human interface device or other entity which can acknowledge that the alarm/event has been noticed. Setting: Uninitialized / Acknowledged / Unacknowledged	Uninitialized
Alarm State	R	A discrete enumeration which gives an indication of whether the alert is active and whether it has been reported. Setting: Uninitialized / Clear - reported / Clear - not reported / Active - reported / Active - not reported	Uninitialized
Time Stamp	R	The time when evaluation of the block was started and a change in alarm/event state was detected that is unreported. The time stamp value will be maintained constant until alert confirmation has been received - even if another change of state occurs. Setting: MM / DD / YY (Month / Day / Year) HH:MM:SS (Hour:Minute:Second)	Uninitialized
Subcode	R	An enumeration specifying the cause of the alert to be reported. Setting: Other / Block Configuration / Link Configuration / Simulation Active / Local Override / Device Fault State / Device Maintenance / Input Failure / Output Failure / Memory Failure / Lost Static Data / Lost NV Data / Readback Check / Maintenance Needed / Power Up / Out Of Service	Other
Value	R	The value of the associated parameter at the time the alert was detected. Setting: 0...255	0
UPDATE_EVT Update Event		This alert is generated by any change to the static data.	-
Unacknowledged	R/W	A discrete enumeration which is set to "Unacknowledged" when an alarm occurs, and set to "Acknowledged" by a write from a human interface device or other entity which can acknowledge that the alarm/event has been noticed. Setting: Uninitialized / Acknowledged / Unacknowledged	Uninitialized

Parameter DD name	Access	Description and settings	Initial Value
Update State	R	A discrete enumeration which gives an indication of whether the alert has been reported. Setting: Uninitialized / Update reported / Update not reported	Uninitialized
Time Stamp	R	The time when evaluation of the block was started and a change in alarm/event state was detected that is unreported. The time stamp value will be maintained constant until alert confirmation has been received - even if another change of state occurs. Time stamp records the time when parameter was updated. Setting: MM / DD / YY (Month / Day / Year) HH:MM:SS (Hour:Minute:Second)	Uninitialized
Static Revision	R	The static revision of the block whose static parameter was changed and is being reported. It is possible for the present value of static revision to be greater than this because static can be changed at any time. Setting: 0...65535	0
Relative Index	R	The OD index of the static parameter whose change caused this alert, minus the FB starting index. If the update event was caused by a write to multiple parameters at the same time, then this attribute will be zero. Setting: 0...65535	0
COLLECTION_DIRECTORY Collection Directory		A directory that specifies the number, starting indices and DD Item IDs of the data collections in each transducer within a Transducer Block.	-
PRIMARY_VALUE_TYPE Primary Value Type	R	The type of measurement represented by the primary value. For example: mass flow, absolute pressure, differential temperature	Volumetric flow
PRIMARY_VALUE volume flow		The measured volume flow value and status available to the Function Block.	-
STATUS Status	R	Digital transducers, unlike their analogue versions, can detect faults that make the measurement bad or prevent the actuator from responding. This additional, valuable information will be passed along with each transmission of a data value in the form of a status attribute.	-
VALUE Value	R	A numerical quantity entered by a user or calculated by the algorithm.	-
PRIMARY_VALUE_RANGE Volume Flow range		The high and low range limit values, the engineering units code and the number of digits to the right of the decimal point to be used to display the Primary Value.	-
EU_100 max value	R	The engineering unit value which represents the upper end of range of the associated Block Parameter.	NaN
EU_0 min value	R	The engineering unit value which represents the lower end of range of the associated Block Parameter.	-NaN
UNITS_INDEX Units Index	R/W	Device Description units code index for the engineering unit descriptor for the associated block value. Settings: m ³ /s; m ³ /min; m ³ /h; m ³ /d; L/s; L/min; L/h; L/d; kL/s; kL/min; kL/h; kL/d; mL/min; CFS; CFM; CFH; ft ³ /d; kCFS; kCFM; kCFH; kft ³ /d; gal/s; GPM; gal/h; gal/d; bbl/s; bbl/min; bbl/h; bbl/d; ImpGal/s; ImpGal/min; ImpGal/h; ImpGal/d	m ³ /h

Parameter DD name	Access	Description and settings	Initial Value
DECIMAL Decimal	R	The number of digits to the right of the decimal point which should be used by an interface device in displaying the specified parameter.	1
PRIMARY_VALUE_103 Flow Velocity		The measured value and status available to the Function Block.	-
STATUS Status	R	Digital transducers, unlike their analogue versions, can detect faults that make the measurement bad or prevent the actuator from responding. This additional, valuable information will be passed along with each transmission of a data value in the form of a status attribute.	-
VALUE Value	R	A numerical quantity entered by a user or calculated by the algorithm.	-
PRIMARY_VALUE_RANGE_103 Flow Velocity Range		The high and low range limit values, the engineering units code and the number of digits to the right of the decimal point to be used to display the Primary Value.	-
EU_100 max value	R	The engineering unit value which represents the upper end of range of the associated Block Parameter.	NaN
EU_0 min value	R	The engineering unit value which represents the lower end of range of the associated Block Parameter.	-NaN
UNITS_INDEX Units Index	R/W	Device Description units code index for the engineering unit descriptor for the associated block value. Settings: m/s; mm/s; m/h; km/h; in/s; ft/s; yd/s; in/min; ft/min; yd/min; in/h; ft/h; yd/h	m/s
DECIMAL Decimal (Point)	R	The number of digits to the right of the decimal point which should be used by an interface device in displaying the specified parameter.	0
AVERAGING_MAX_STACKING Averaging - Max. stacking	R/W	Max. stacking (Fct. D1.8.3) Settings: 0...7	7
AVERAGING_MIN_STACKING Averaging - Min. stacking	R/W	Min. stacking (Fct. D1.8.2) Settings: 0...7	0
AVERAGING_MODE Averaging Mode	R/W	Mode (Fct. D1.8.1) Settings: Off / On	Off
BLOCK_ERR_DESC_1 Block Error Description	R	This parameter is used by a device to report more specific details regarding persistent errors that are reported through BLOCK_ERR. Settings: TB is OOS	Uninitialized
CAL_ACTION Calibration	R/W	Selector to start a calibration. Settings: PROTECT_INFO = Service Level: no action / zero factory calibration / zero automatic calibration / path factory calibration / path calibration / store calibration / discard calibration PROTECT_INFO <> Service Level: no action / zero factory calibration / zero automatic calibration / store calibration / discard calibration	no action

Parameter DD name	Access	Description and settings	Initial Value
CAL_LAST_RESULT Calib. Result	R	Settings: idle Zero calibration: Passed / Failed / 0 % / 10 % / 20 % / 30 % / 40 % / 50 % / 60 % / 70 % / 80 % / 90 % / 100 % Path calibration: Passed / Failed / 0 % / 10 % / 20 % / 30 % / 40 % / 50 % / 60 % / 70 % / 80 % / 90 % / 100 %	idle
COUNTER_DECREASE Counter Decrease	R/W	Plausibility counter decrement setting. Number of counts to be decreased on the plausibility counter when the actual measured value is within the error limits (Fct. C1.4.2). Settings: 1...99	1
COUNTER_LIMIT Counter Limit	R/W	Limit setting for the plausibility counter. When this limit is reached, the measured value will not be discarded when it exceeds the error limit (Fct. C1.4.3). Settings: 0...999	0
DEAD_TIME Dead Time	R/W	Dead time (Fct. D1.7) Settings: 0.0...300.0 μ s	2.0 μ s
DENSITY Density	R/W	Sets the density of the fluid (Fct. C1.9). Settings: 0.1...5.0 kg/L	1.00 kg/L
DYN_VISCOSITY Dynamic viscosity	R/W	Dynamic viscosity of fluid (Fct. C1.7.2) Settings: 0.1...5000.0 cP	1.0 cP
ERROR_LIMIT Error Limit	R/W	In percentage of the measured value. If the measured value exceeds this limit compared to the previous measured value, the measured value will be discarded and the plausibility counter will be increased (Fct. C1.4.1). Settings: 0.0...100.00	10.0
FLOW_DIRECTION Flow Direction	R/W	Selects the direction of the measured flow (Fct. C1.3.2). Settings: normal / reverse	normal
FLUID_VOS Velocity of Sound	R/W	Velocity of Sound (Fct. D2.2.1) Settings: 500.0...3000.0 m/s	1485.0 m/s
GK_VALUE GK	R/W	Sets the meter factor (Fct. C1.2.2). Settings: 0.5...10.00	1.0
HYSTERISIS LFC hysteresis	R/W	Low flow cutoff hysteresis (Fct. C1.3.4). Settings: 0.0...100.00 m/s	0.0 m/s
LIMITATION_MAX Upper Limit	R/W	Upper limitation of all flow values , before smoothing by time constant, affects all outputs (Fct. C1.3.1). Settings: 0.0010...1000.0 m/s	20.0 m/s

Parameter DD name	Access	Description and settings	Initial Value
LIMITATION_MIN Lower Limit	R/W	Lower limitation of all flow values , before smoothing by time constant, affects all outputs (Fct. C1.3.1).	-20.0 m/s
		Settings: -0.0010...-1000.0 m/s	
LINEARIZATION Linearization	R/W	(Compensation for errors made at different Reynolds Numbers (Fct. C1.7.1).	off
		Settings: off / on	
LOW_FLOW_CUTOFF Low flow cutoff	R/W	Sets the low flow cutoff (Fct. C1.3.4).	0.0 m/s
		Settings: 0.0...100.0 m/s	
METER_SIZE_FREE_VAL Meter size	R/W	Sets the pipe diameter (Fct. C1.1).	100.0 mm
		Settings: 25.0...3000.0 mm	
METER_SIZE_TBL_VAL Meter size	R/W	Sets the pipe diameter (Fct. C1.1).	100 mm
		Settings: 250:25 mm (1 inch) / 320:32 mm (1.25 inch) / 400:40 mm (1.5 inch) / 500:50 mm (2 inch) / 650:65 mm (2.5 inch) / 800:80 mm (3 inch) / 1000:100 mm (4 inch) / 1250:125 mm (5 inch) / 1500:150 mm (6 inch) / 2000:200 mm (8 inch) / 2500:250 mm (10 inch) / 3000:300 mm (12 inch) / 3500:350 mm (14 inch) / 4000:400 mm (16 inch) / 4500:450 mm (18 inch) / 5000:500 mm (20 inch) / 5500:550 mm (22 inch) / 6000:600 mm (24 inch) / 6500:650 mm (26 inch) / 7000:700 mm (28 inch) / 7500:750 mm (30 inch) / 8000:800 mm (32 inch) / 8500:850 mm (34 inch) / 9000:900 mm (36 inch) / 9500:950 mm (38 inch) / 10000:1000 mm (40 inch) / 10500:1050 mm (42 inch) / 11000:1100 mm (44 inch) / 11500:1150 mm (46 inch) / 12000:1200 mm (48 inch) / 12500:1250 mm (50 inch) / 13000:1300 mm (52 inch) / 13500:1350 mm (54 inch) / 14000:1400 mm (56 inch) / 14500:1450 mm (58 inch) / 15000:1500 mm (60 inch) / 16000:1600 mm (64 inch) / 17000:1700 mm (68 inch) / 18000:1800 mm (72 inch) / 19000:1900 mm (76 inch) / 20000:2000 mm (80 inch) / 21000:2100 mm (84 inch) / 22000:2200 mm (88 inch) / 23000:2300 mm (92 inch) / 24000:2400 mm (96 inch) / 25000:2500 mm (100 inch) / 26000:2600 mm (104 inch) / 27000:2700 mm (108 inch) / 28000:2800 mm (112 inch) / 29000:2900 mm (116 inch) / 30000:3000 mm (120 inch)	
NUM_PATHS Number of paths	R/W	Sets the number of active paths (Fct. D2.1).	3 paths
		Settings: 1 path / 2 paths / 3 paths	
PATH_LENGTH_1 Path length 1	R/W	Shows/Sets the length of path 1 (Fct. D2.3).	100 mm
		Settings: 12.5...6000.0 mm	
PATH_LENGTH_2 Path length 2	R/W	Shows/Sets the length of path 2 (Fct. D2.4).	100 mm
		Settings: 12.5...6000.0 mm	
PATH_LENGTH_3 Path length 3	R/W	Shows/Sets the length of path 3 (Fct. D2.5).	100 mm
		Settings: 12.5...6000.0 mm	
PING_TIME Ping time	R/W	Ping time (Fct. D1.11)	15.5 ms
		Settings: 5.0...15.0 ms	

Parameter DD name	Access	Description and settings	Initial Value
PIPE_TEMPERATURE Pipe temperature	R/W	Input of operational temperature for correction of the thermal expansion (Fct. C1.8).	20.0 °C
		Settings: -200.0...700.0 °C	
PROTECT_INFO Access Protection	R	Current protection level to restricted parameters.	Uninitialized
		Settings: Write Lock / Custody Transfer / Production / Service level / User / bit 5 / bit 6 / Concentration	
PULSE_FORM Pulse form	R/W	Pulse form (Fct. D1.4)	Sine
		Settings: Sine / Double sine	
SECONDARY_VALUE Mass Flow Range		The measured value and status available to the Function Block.	-
STATUS Status	R	Digital transducers, unlike their analogue versions, can detect faults that make the measurement bad or prevent the actuator from responding. This additional, valuable information will be passed along with each transmission of a data value in the form of a status attribute.	-
VALUE Value	R	A numerical quantity entered by a user or calculated by the algorithm.	-
SECONDARY_VALUE_RANGE Mass Flow Range		Defines the ends of the SECONDARY_VALUE, the units of the SECONDARY_VALUE, and the decimal point position (number of significant digits to the right of the point). The engineering units must match the units selected in the parameter XD_SCALE of the Analog Input Block that reads the channel with this value.	-
EU_100 max value	R	The engineering unit value which represents the upper end of range of the associated Block Parameter.	200
EU_0 min value	R	The engineering unit value which represents the lower end of range of the associated Block Parameter.	0
UNITS_INDEX Units Index	R/W	Device Description units code index for the engineering unit descriptor for the associated block value.	kg/h
		Settings: kg/s; kg/min; kg/h; kg/d; t/s; t/min; t/h; t/d;g/s; g/min; g/h; g/d; lb/s; lb/min; lb/h; lb/d; klb(US)/s; klb(US)/min; klb(US)/h; klb(US)/d; st/s = (Ston/s); st/min = (Ston/min); st/h = (Ston/h); st/d = (Ston/d); lt/s = (LTon/s); lt/min = (Lton/min); lt/h = (Lton/h); lt/d = (Lton/d)	
DECIMAL Decimal (Point)	R	The number of digits to the right of the decimal point which should be used by an interface device in displaying the specified parameter.	0
SECONDARY_VALUE_TYPE Secondary Value Type	R	The type of measurement represented by the secondary value. For Example: Mass Flow, Absolute Pressure, Differential Temperature.	Mass flow
		Settings: Mass flow	
SENSOR_CAL_DATE Sensor Calibration Date	R	The date of the last sensor calibration.	-
SENSOR_CAL_LOC Sensor Calibration Location	R/W	The last physical location at which the sensor was calibrated. (ex. Acme Labs)	-

Parameter DD name	Access	Description and settings	Initial Value
SENSOR_CAL_ WHO Sensor Calibration Who	R/W	The name of the person responsible for the last sensor calibration.	-
SENSOR_SN Sensor Serial Number	R	The sensor serial number.	-
SENSOR_TYPE Sensor Type	R	The type of sensor. Settings: Ultrasonic (time of travel)	Ultrasonic (time of travel)
SIZE_ENTRY Size entry	R/W	Switches between a free value or a table value for the input of the diameter (Fct. D4.4). Settings: value in [mm] / table [mm , inch]	table
SNR SNR	R/W	SNR (Fct. D1.10) Settings: Raw / Filtered	Filtered
T_EXP_COEFF T expansion coeff.	R/W	Sets the temperature expansion coefficient (Fct. D2.9). Settings: 0.0...0.0001 1/°C	1.15e-5°C
TIME_CONSTANT Time Constant	R/W	Time constant on the Front End for flow-related measurement (volume, mass, flow velocity) (Fct. C1.3.3). Settings: 0.0...1000.0 s	0.0 s
TRACKING Tracking	R/W	Tracking (Fct. D1.9) Settings: Normal / Fast	Normal
TRANSDUCER_ DIRECTORY Transducer Directory Entry		A directory that specifies the number and starting indices of the data collections in the transducer block.	0
TRANSDUCER_ FREQ Transducer Frequency	R/W	Sets the frequency of the transducer (Fct. D1.1). Settings: 1 MHz / 2 MHz / 500 kHz	1 MHz
TRANSDUCER_ TYPE Transducer Type	R	Identifies the transducer that follows.	Other
TRANSDUCER_ TYPE_VER Transducer Type Version	R	Identifies the version of the transducer that follows. Format is XYY where XX is the major spec revision and YY is the manufacturer revision.	0
Trigger_Level Trigger Level	R/W	Trigger level (Fct. D1.5) Settings: -99.0...99.0 %	30.0 %
Trigger_Margin Trigger Margin	R/W	Trigger margin (Fct. D1.6) Settings: 0.0...50.0 %	5.0 %
WEIGHT_1 Weight 1	R/W	Sets the weight of path 1 (Fct. D2.6). Settings: 0.0...1.0	1.0

Parameter DD name	Access	Description and settings	Initial Value
WEIGHT_2 Weight 2	R/W	Sets the weight of path 2 (Fct. D2.7).	1.0
		Settings: 0.0...1.0	
WEIGHT_3 Weight 3	R/W	Sets the weight of path 3 (Fct. D2.8).	1.0
		Settings: 0.0...1.0	
WINDOW_END Window End	R/W	Window end (Fct. D1.3)	2000.0 µs
		Settings: 15.0...3200.0 µs	
WINDOW_START Window Start	R/W	Window start (Fct. D1.2)	32.0 µs
		Settings: 15.0...3200.0 µs	
XD_ERROR Transducer Error		One of the transducer error codes defined in the FF Transducer Specifications in section "4.7 Block Alarm Subcodes".	Uninitialized
		Settings: <ul style="list-style-type: none"> • 16: Unspecified error • 17: General error • 18: Calibration error • 19: Configuration error • 20: Electronics Failure • 21: Mechanical Failure • 22: I/O Failure • 23: Data Integrity Error • 24: Software Error • 25: Algorithm Error 	
ZERO_PATH_1 Zero Offs. - Path 1	R/W	Result of zero calibration for path 1 (Fct. D3.1.1).	0.0 ps
		Settings: -1000000...1000000 ps	
ZERO_PATH_2 Zero Offs. - Path 2	R/W	Result of zero calibration for path 2 (Fct. D3.1.2).	0.0 ps
		Settings: -1000000...1000000 ps	
ZERO_PATH_3 Zero Offs. - Path 3	R/W	Result of zero calibration for path 3 (Fct. D3.1.3).	0.0 ps
		Settings: -1000000...1000000 ps	

4.7 DIAGTB (Diagnose Transducer Block)

Parameter DD name	Access	Description and settings	Initial Value
ALERT_KEY Alert Key	R/W	The identification number of the plant unit. This information may be used in the host for sorting alarms, etc. Setting: 1...255	0
BLOCK_ERR Block Error	R	This parameter reflects the error status associated with the hardware or software components associated with a block. It is a bit string, so that multiple errors may be shown. Setting: <ul style="list-style-type: none"> • Other: Non-specific error active • Block Configuration: Error detected in block configuration • Link Configuration: Error detected in link configuration • Simulation Active: Simulation enabled in this block • Local Override: Output tracking of faultstate active • Device Fault State: Device faultstate set • Device Maintenance: Device needs maintenance soon • Input Failure: Process variable has bad status • Output Failure: Failure detected in output hardware • Memory Failure: Memory error detected • Lost Static Data: Static parameters cannot be recovered • Lost NV Data: Non-volatile parameters cannot be recovered • Readback Check: Failure detected in READBACK • Maintenance Needed: Device NEEDS maintenance NOW • Power Up: Recovery from power failure • Out Of Service: Block actual mode is out of service 	Other
MODE_BLK Block Mode		The actual, target, permitted and normal modes of the block.	-
TARGET Target	R/W	This is the mode requested by the operator. Only one mode from those allowed by the permitted mode parameter may be requested. Setting: Auto / OOS	Auto
ACTUAL Actual	R	This is the current mode of the block, which may differ from the target based on operating conditions. Its value is calculated as part of block execution. Setting: Auto / OOS	Auto
PERMITTED Permitted	R/W	Defines the modes which are allowed for an instance of the block. The permitted mode is configured based on application requirement. Setting: Auto / OOS	Auto OOS
NORMAL Normal	R/W	This is the mode which the block should be set to during normal operating conditions. Setting: Auto / OOS	Auto
ST_Rev Static Revision	R	The revision level of the static data associated with the function block. The revision value will be incremented each time a static parameter value in the block is changed. Setting: 0...65535	0

Parameter DD name	Access	Description and settings	Initial Value
STRATEGY Strategy	R/W	The strategy field can be used to identify grouping of blocks. This data is not checked or processed by the block. Setting: 0...65535	0
TAG_DESC Tag Description	R/W	The user description of the intended application of the block. Setting: ≤32 digits	blanks
BLOCK_ALM Block Alarm		The block alarm is used for all configuration, hardware, connection failure or system problems in the block. The cause of the alert is entered in the subcode field. The first alert to become active will set the "Active" status in the "Status" attribute. As soon as the "Unreported" status is cleared by the alert reporting task, another block alert may be reported without clearing the "Active" status, if the subcode has changed.	-
Unacknowledged	R/W	A discrete enumeration which is set to "Unacknowledged" when an alarm occurs, and set to "Acknowledged" by a write from a human interface device or other entity which can acknowledge that the alarm/event has been noticed. Setting: Uninitialized / Acknowledged / Unacknowledged	Uninitialized
Alarm State	R	A discrete enumeration which gives an indication of whether the alert is active and whether it has been reported. Setting: Uninitialized / Clear - reported / Clear - not reported / Active - reported / Active - not reported	Uninitialized
Time Stamp	R	The time when evaluation of the block was started and a change in alarm/event state was detected that is unreported. The time stamp value will be maintained constant until alert confirmation has been received - even if another change of state occurs. Setting: MM / DD / YY (Month / Day / Year) HH:MM:SS (Hour:Minute:Second)	Uninitialized
Subcode	R	An enumeration specifying the cause of the alert to be reported. Setting: Other / Block Configuration / Link Configuration / Simulation Active / Local Override / Device Fault State / Device Maintenance / Input Failure / Output Failure / Memory Failure / Lost Static Data / Lost NV Data / Readback Check / Maintenance Needed / Power Up / Out Of Service	Other
Value	R	The value of the associated parameter at the time the alert was detected. Setting: 0...255	0
UPDATE_EVT Update Event		This alert is generated by any change to the static data.	-
Unacknowledged	R/W	A discrete enumeration which is set to "Unacknowledged" when an alarm occurs, and set to "Acknowledged" by a write from a human interface device or other entity which can acknowledge that the alarm/event has been noticed. Setting: Uninitialized / Acknowledged / Unacknowledged	Uninitialized

Parameter DD name	Access	Description and settings	Initial Value
Update State	R	A discrete enumeration which gives an indication of whether the alert has been reported. Setting: Uninitialized / Update reported / Update not reported	Uninitialized
Time Stamp	R	The time when evaluation of the block was started and a change in alarm/event state was detected that is unreported. The time stamp value will be maintained constant until alert confirmation has been received - even if another change of state occurs. Time stamp records the time when parameter was updated. Setting: MM / DD / YY (Month / Day / Year) HH:MM:SS (Hour:Minute:Second)	Uninitialized
Static Revision	R	The static revision of the block whose static parameter was changed and is being reported. It is possible for the present value of static revision to be greater than this because static can be changed at any time. Setting: 0...65535	0
Relative Index	R	The OD index of the static parameter whose change caused this alert, minus the FB starting index. If the update event was caused by a write to multiple parameters at the same time, then this attribute will be zero. Setting: 0...65535	0
COLLECTION_DIRECTORY Collection Directory		A directory that specifies the number, starting indices and DD Item IDs of the data collections in each transducer within a Transducer Block.	-
PRIMARY_VALUE_201 Velocity of Sound		The measured velocity of sound value and status available to the Function Block.	-
STATUS Status	R	Digital transducers, unlike their analogue versions, can detect faults that make the measurement bad or prevent the actuator from responding. This additional, valuable information will be passed along with each transmission of a data value in the form of a status attribute.	-
VALUE Value	R	A numerical quantity entered by a user or calculated by the algorithm.	-
PRIMARY_VALUE_RANGE_201 Velocity of Sound Range		The high and low range limit values, the engineering units code and the number of digits to the right of the decimal point to be used to display the Primary Value.	-
EU_100 max value	R	The engineering unit value which represents the upper end of range of the associated Block Parameter.	3000.0
EU_0 min value	R	The engineering unit value which represents the lower end of range of the associated Block Parameter.	0.0
UNITS_INDEX Units Index	R/W	Device Description units code index for the engineering unit descriptor for the associated block value. Settings: m/s; mm/s; m/h; km/h; in/s; ft/s; yd/s; in/min; ft/min; yd/min; in/h; ft/h; yd/h	m/s
DECIMAL Decimal	R	The number of digits to the right of the decimal point which should be used by an interface device in displaying the specified parameter.	2

Parameter DD name	Access	Description and settings	Initial Value
PRIMARY_VALUE_202 Gain		The measured value and status available to the Function Block.	-
STATUS Status	R	Digital transducers, unlike their analogue versions, can detect faults that make the measurement bad or prevent the actuator from responding. This additional, valuable information will be passed along with each transmission of a data value in the form of a status attribute.	-
VALUE Value	R	A numerical quantity entered by a user or calculated by the algorithm.	-
PRIMARY_VALUE_RANGE_202 Gain Range		The high and low range limit values, the engineering units code and the number of digits to the right of the decimal point to be used to display the Primary Value.	-
EU_100 max value	R	The engineering unit value which represents the upper end of range of the associated Block Parameter.	100.0
EU_0 min value	R	The engineering unit value which represents the lower end of range of the associated Block Parameter.	-0.0
UNITS_INDEX Units Index	R/W	Device Description units code index for the engineering unit descriptor for the associated block value. Settings: dB	dB
DECIMAL Decimal (Point)	R	The number of digits to the right of the decimal point which should be used by an interface device in displaying the specified parameter.	2
PRIMARY_VALUE_203 SNR		The measured value and status available to the Function Block.	-
STATUS Status	R	Digital transducers, unlike their analogue versions, can detect faults that make the measurement bad or prevent the actuator from responding. This additional, valuable information will be passed along with each transmission of a data value in the form of a status attribute.	-
VALUE Value	R	A numerical quantity entered by a user or calculated by the algorithm.	-
PRIMARY_VALUE_RANGE_203 SNR Range		The high and low range limit values, the engineering units code and the number of digits to the right of the decimal point to be used to display the Primary Value.	-
EU_100 max value	R	The engineering unit value which represents the upper end of range of the associated Block Parameter.	100.0
EU_0 min value	R	The engineering unit value which represents the lower end of range of the associated Block Parameter.	-0.0
UNITS_INDEX Units Index	R/W	Device Description units code index for the engineering unit descriptor for the associated block value. Settings: dB	dB
DECIMAL Decimal (Point)	R	The number of digits to the right of the decimal point which should be used by an interface device in displaying the specified parameter.	2
PRIMARY_VALUE_204 Electronic Temperature		The measured value and status available to the Function Block.	-
STATUS Status	R	Digital transducers, unlike their analogue versions, can detect faults that make the measurement bad or prevent the actuator from responding. This additional, valuable information will be passed along with each transmission of a data value in the form of a status attribute.	-

Parameter DD name	Access	Description and settings	Initial Value
VALUE Value	R	A numerical quantity entered by a user or calculated by the algorithm.	-
PRIMARY_VALUE_ RANGE_204 Electronic Temperature Range		The high and low range limit values, the engineering units code and the number of digits to the right of the decimal point to be used to display the Primary Value.	-
EU_100 max value	R	The engineering unit value which represents the upper end of range of the associated Block Parameter.	500.0
EU_0 min value	R	The engineering unit value which represents the lower end of range of the associated Block Parameter.	-200.0
UNITS_INDEX Units Index	R/W	Device Description units code index for the engineering unit descriptor for the associated block value. Settings: K; °C; °F	°C
DECIMAL Decimal (Point)	R	The number of digits to the right of the decimal point which should be used by an interface device in displaying the specified parameter.	2
C_NUM_ DETECTED C-Number Device	R	Current C-Number of this device (Fct. D5.1).	-
C_NUM_ PRODUCTION C-Number Production	R	C-Number of production; this number identifies the type of electronics, can be found on the converter assembly sticker as well (Fct. B3.3, C5.1.2).	-
DEVICE_SN Device serial no.	R	Displays the serial number of the system (Fct. C5.1.3).	-
DIAGNOSIS_ VALUE_1 Diagnosis 1 Value	R	Diagnosis 1 value	0.0 m/s
DIAGNOSIS_ VALUE_2 Diagnosis 2 Value	R	Diagnosis 2 value	0.0 dB
ELECTRONIC_ INFO Electronic Revision		Displays information of the Electronics Revision. Displays the Electronics Revision of the electronics (Fct. B3.8, C5.1.6).	-
IDENT_NUMBER ID-No. Board	R	ID No. of the circuit board.	-
SOFTWARE_VER Software version	R	Software version	-
PRODUCTION_ DATE Production date	R	Production date	-
ELECTRONIC_SN Electronic serial no.	R	Displays the serial number of the electronics (Fct. C5.1.4).	-
FIELDBUS_INFO Foundation Fieldb	R	Displays information of the Foundation Fieldbus interface (Fct. B3.7).	-
IDENT_NUMBER ID-No. Board	R	ID No. of the circuit board.	-
SOFTWARE_VER Software version	R	Software version	-
PRODUCTION_ DATE Production date	R	Production date	-

Parameter DD name	Access	Description and settings	Initial Value
MAIN_SW_INFO SW.REV.MS		Displays information of Main Software (Fct. B3.5).	
IDENT_NUMBER ID-No. Board	R	ID No. of the circuit board.	-
SOFTWARE_VER Software version	R	Software version	-
PRODUCTION_ DATE Production date	R	Production date	-
NUM_PATHS Number of paths	R	Number of active paths. Settings: 1 path / 2 paths / 3 paths	3 paths
OPERATING_ HOURS Operating hours	R	Operating hour since first power up (Fct. B2.8).	-
REYNOLDS_ NUMBER Reynolds number	R	Actual reynolds number (Fct. B2.7).	0.0
SELECTOR_ DIAGNOSIS_1 Selector Diagnosis 1	R	Select options for diagnosis 1 (Fct. C1.10.1). Settings: Number of paths = 1: none / velocity of sound 1 / flow speed 1 Number of paths = 2: none / velocity of sound 1 / velocity of sound 2 / flow speed 1 / flow speed 2 Number of paths = 3: none / velocity of sound 1 / velocity of sound 2 / velocity of sound 3 / flow speed 1 / flow speed 2 / flow speed 3	none
SELECTOR_ DIAGNOSIS_2 Selector Diagnosis 2	R	Select options for diagnosis 1 (Fct. C1.10.2). Settings: Number of paths = 1: none / gain 1 / SNR 1 Number of paths = 2: none / gain 1 / gain 2 / SNR 1 / SNR 2 Number of paths = 3: none / gain 1 / gain 2 / gain 3 / SNR 1 / SNR 2 / SNR 3	none
SENSOR_CPU_ INFO Sensor CPU		Displays information of the sensor CPU software. Displays the ID of CPU on the FrontEnd (Fct. B3.4.1 , C1.6.1).	-
IDENT_NUMBER ID-No. Board	R	ID No. of the circuit board.	-
SOFTWARE_VER Software version	R	Software version	-
PRODUCTION_ DATE Production date	R	Production date	-
SENSOR_DRIVER_ INFO Sensor Driver		Displays information of the sensor driver hardware. Displays the ID of the Sensor Driver on the FrontEnd (Fct. B3.4.3, C1.6.3).	-
IDENT_NUMBER ID-No. Board	R	ID No. of the circuit board.	-
SOFTWARE_VER Software version	R	Software version	-
PRODUCTION_ DATE Production date	R	Production date	-

Parameter DD name	Access	Description and settings	Initial Value
SENSOR_DSP_INFO Sensor DSP		Displays information of the sensor DSP software. Displays the ID of the DSP on the FrontEnd (Fct. B3.4.2, C1.6.2).	-
IDENT_NUMBER ID-No. Board	R	ID No. of the circuit board.	-
SOFTWARE_VER Software version	R	Software version	-
PRODUCTION_DATE Production date	R	Production date	-
USER_INTERFACE SW.REV.UIS		Displays information of User Interface (Fct. B3.6).	-
IDENT_NUMBER ID-No. Board	R	ID No. of the circuit board.	-
SOFTWARE_VER Software version	R	Software version	-
PRODUCTION_DATE Production date	R	Production date	-
TRANSDUCER_DIRECTORY Transducer Directory Entry		A directory that specifies the number and starting indices of the data collections in the transducer block.	0
TRANSDUCER_TYPE Transducer Type	R	Identifies the transducer that follows.	Other
XD_ERROR Transducer Error		<p>One of the transducer error codes defined in the FF Transducer Specifications in section "4.7 Block Alarm Subcodes".</p> <p>Settings:</p> <ul style="list-style-type: none"> • 16: Unspecified error • 17: General error • 18: Calibration error • 19: Configuration error • 20: Electronics Failure • 21: Mechanical Failure • 22: I/O Failure • 23: Data Integrity Error • 24: Software Error • 25: Algorithm Error 	Uninitialized
V_NO_SENSOR V no. sensor	R	Displays the order number of the measuring sensor (Fct. C1.6.6).	

4.8 Integrator Block (IT)

The following tables list the 2 Integrator Block parameters in alphabetical order.

It describes characteristics of the signal converter measurements for forward (positive) and reverse (negative) flow at the same time. Both integrators were intended to totalize the forward flow Integrator 1 (+ Flow Totalizer) on the one hand and the reverse flow Integrator 2 (- Flow Totalizer) on the other. The configuration of these blocks is almost the same, unless stated differently.

The following tables contain short parameter description, factory settings (Initial Value (IV)) and possible settings.

Parameter DD name	Access	Description and settings	Initial Value
Alert Key	R/W	The identification number of the plant unit. This information may be used in the host for sorting alarms, etc. Setting: 0...255	0
BLOCK_ERR Block Error	R	This parameter reflects the error status associated with the hardware or software components associated with a block. It is a bit string, so that multiple errors may be shown. Setting: <ul style="list-style-type: none"> • Other: Non-specific error active • Block Configuration: Error detected in block configuration • Simulation Active: Simulation enabled in this block • Local Override: Output tracking of faultstate active • Device Fault State: Device faultstate set • Device Maintenance: Device needs maintenance soon • Input Failure: Process variable has bad status • Output Failure: Failure detected in output hardware • Memory Failure: Memory error detected • Lost Static Data: Static parameters cannot be recovered • Lost NV Data: Non-volatile parameters cannot be recovered • Readback Check: Failure detected in READBACK • Maintenance Needed: Device NEEDS maintenance NOW • Power Up: Recovery from power failure • Out Of Service: Block actual mode is out of service 	Actual measured value
MODE_BLK Block Mode	Mix	The actual, target, permitted and normal modes of the block.	-
TARGET Target	R/W	By setting this parameter to an allowed value (one of the value from permitted modes) user can change the block execution mode. Changing of modes is required to change the access permissions available to various parameters. Setting: Auto / Manual / OOS	OOS
ACTUAL Actual	R	This is the current mode of the block, which may differ from the target based on operating conditions. Its value is calculated as part of block execution.	Factory Settings
PERMITTED Permitted	R/W	This parameter defines allowed modes for this function block and can be set by user. Setting: Auto / Manual / OOS	Auto, Manual or OOS

Parameter DD name	Access	Description and settings	Initial Value
NORMAL Normal	R/W	This is the mode which the block should be set to during normal operating conditions.	Auto
		Setting: Auto	
ST_REV Static Revision	R	The revision level of the static data associated with the function block. The revision value will be incremented each time a static parameter value in the block is changed.	0
		Setting: 0...65535	
STRATEGY Strategy	R/W	The strategy field can be used to identify grouping of blocks. This data is not checked or processed by the block.	0 (=uninitialized)
		Setting: 0...65535	
TAG_DESC Tag Description	R/W	This is the user description of the block useful for documentation purpose. Not being updated frequently as it is not being accessed by application.	spaces
		Setting: ≤32 digits	
BLOCK_ALM Block Alarm	Mix	The block alarm is used for all configuration, hardware, connection failure or system problems in the block. The cause of the alert is entered in the subcode field. The first alert to become active will set the "Active" status in the "Status" attribute. As soon as the "Unreported" status is cleared by the alert reporting task, another block alert may be reported without clearing the "Active" status, if the subcode has changed.	-
Unacknowledged	R/W	A discrete enumeration which is set to "Unacknowledged" when an alarm occurs, and set to "Acknowledged" by a write from a human interface device or other entity which can acknowledge that the alarm/event has been noticed.	Uninitialized
		Setting: Uninitialized / Acknowledged / Unacknowledged	
Alarm State	R	A discrete enumeration which gives an indication of whether the alert is active and whether it has been reported.	Uninitialized
		Setting: Uninitialized / Clear - reported / Clear - not reported / Active - reported / Active - not reported	
Time Stamp	R	The time when evaluation of the block was started and a change in alarm/event state was detected that is unreported. The time stamp value will be maintained constant until alert confirmation has been received - even if another change of state occurs.	Uninitialized
		Setting: MM / DD / YY (Month / Day / Year) HH:MM:SS (Hour:Minute:Second)	
Subcode	R	An enumeration specifying the cause of the alert to be reported.	Other
		Setting: Other / Block Configuration / Link Configuration / Simulation Active / Local Override / Device Fault State / Device Maintenance / Input Failure / Output Failure / Memory Failure / Lost Static Data / Lost NV Data / Readback Check / Maintenance Needed / Power Up / Out Of Service	
Value	R	The value of the associated parameter at the time the alert was detected.	0
		Setting: 0...255	

Parameter DD name	Access	Description and settings	Initial Value
CLOCK_PER Clock Period	R/W	Establishes the period for periodic reset, in seconds.	0
		Setting: Positive or 0	
GOOD_LIM Good Limit	R/W	Sets the limit for PCT_INCL. Below this limit OUT receives the status good.	0
		Setting: 0...100%	
GRANT_DENY Grant Deny	R/W	Options for controlling access of host computers and local control panels to operating, tuning and alarm parameters of the block.	-
Grant	R/W	Depending on the philosophy of the plant, the operator or a higher level device (HLD), or a local operator's panel (LOP) in the case of Local, may turn on an item of the Grant attribute - Program, Tune, Alarm or Local.	Uninitialized
		Setting: Program / Tune / Alarm / Local	
Deny	R/W	The Denied attribute is provided for use by a monitoring application in an interface device and may not be changed by an operator.	Uninitialized
		Setting: Program denied / Tune denied / Alarm denied / Local denied	
IN_1 Input 1	R/W	Input 1 of the Integrator Block.	-
Status		Status of IN_1	
Value		Actual value	
IN_2 Input 2	R/W	Input 2 of the Integrator Block.	-
Status		Status of IN_2	
Value		Actual value	
OUT_PTRIP Output Pre Trip	R/W	The second discrete output.	-
Status	R/W	Setting: Good Non Cascade / Good Cascade / Uncertain / Bad Not Connected / Bad	Bad Not Connected
Value	R/W	Setting: 0: Off / 1: On	0

Parameter DD name	Access	Description and settings	Initial Value
INTEG_OPTS Integration Options	R/W	<p>INTEG_OPTS is to be used to specify several integration options as type of input used in each input, flow direction to be considered in the totalization, status to be considered in the totalization and if the totalization residue shall be used in the next batch after a reset.</p> <p>The following INTEG_OPTS are possible (see also INTEG_TYPE):</p> <ul style="list-style-type: none"> • Input 1 accumulate: IN_1 is used as pulse (otherwise as rate) • Input 2 accumulate: IN_2 is used as pulse (otherwise as rate) • Flow forward: only positive net flow will be taken into account for totalization • Flow reverse: only negative net flow will be taken into account for totalization • Use Uncertain: IN_1 and IN_2 input will be taken into account even if their states are "Uncertain" (otherwise the value with the last "Good" status will be taken) • Use BAD Input: IN_1 or IN_2 with "Bad" status will be interpreted as "Good" (Note: only the status is interpreted as "Good", the value isn't used for totalization, but the good one, i.e. RTOTAL isn't affected with this setting. • Carry: integration after a reset starts with the init value, but with the residual after the trip value. • Add zero if Bad: if one of the input (IN_1 or IN_2) statuses are "Bad", not the last "Good" value is used for totalization, but zero [0]. • Confirm reset: after a manual reset of totalization, the next manual reset must be preceded by a reset confirmation by the control system. • Generate reset event: in case of reset (automatic or manual), an event notification will be sent to the control system. [This function is an option and not supported.] 	Uninitialized
N_RESET Number of Reset	R	Counts the number of resets. It can not be written nor reset.	-
OP_CMD_INT Operator Command Integration	R/W	<p>Operator command. "Reset" resets the totalizer.</p> <p>Setting: 0: Off / 1: Reset</p>	Off
OUT Output	R/W	The primary analog value calculated as a result of executing the function. The display scaling for the corresponding output. It has no effect on the block.	-
Status	R	Actual status of Output.	-
Value	R	Actual value	-
OUT_PTRIP Output Pre Trip	R/W	The second discrete output.	-
Status	R/W	Setting: Good Non Cascade / Good Cascade / Uncertain / Bad Not Connected / Bad	Bad Not Connected
Value	R/W	Setting: 0: Off / 1: On	Off
OUT_RANGE Output Range	R/W	This is the display scaling for the output. It has no effect on the block.	-
EU_100 Engineering Unit 100	R/W	The engineering unit value which represents the upper end of range of the associated block parameter.	100.0
EU_0 Engineering Unit 0	R/W	The engineering unit value which represents the lower end of range of the associated block parameter.	0.0

Parameter DD name	Access	Description and settings	Initial Value
Units Index	R/W	Setting: All units are possible.	-
Decimal Point	R/W	The number of digits to the right of the decimal point which should be used by an interface device in displaying the specified parameter.	0
OUT_TRIP Output Trip	R/W	The first discrete output.	-
Status	R/W	Setting: Good Non Cascade / Good Cascade / Uncertain / Bad Not Connected / Bad	Bad Not Connected
Value	R/W	Setting: 0: Off / 1: On	Off
OUTAGE_LIM Outage Limit	R/W	The maximum tolerated duration for power failure. Setting: Positive or 0	0
PCT_INCL Percentage Increment Calculation	R	Indicates the percentage of inputs with good status compared to the ones with bad or uncertain and bad status.	0.0
PRE_TRIP Pre Trip	R/W	Adjusts the amount of mass, volume or energy that should set OUT_PTRIP when the integration reaches (TOTAL_SP - PRE_TRIP) when counting up or PRE_TRIP when counting down. Setting: Positive or 0	0
PULSE_VAL1 Pulse Value 1	R/W	Determines the mass, volume or energy per pulse. Setting: Positive or 0	0.0
PULSE_VAL2 Pulse Value 2	R/W	Determines the mass, volume or energy per pulse. Setting: Positive or 0	0.0
RESET_CONFIRM Reset Confirm	R/W	Momentary discrete value which can be written by a host to enable further resets, if the option confirm reset in INTEG_OPTS is chosen.	-
Status	R/W	Setting: Good Non Cascade / Good Cascade / Uncertain / Bad Not Connected / Bad / Bad No Comm with Last Useable Value (LUV)	Bad Not Connected
Value	R/W	Setting: 0: Off / 1: On	Off
RESET_IN Reset Input	R/W	Reset the totalizers.	-
Status	R/W	Setting: Good Non Cascade / Good Cascade / Uncertain / Bad Not Connected / Bad / Bad No Comm with Last Useable Value (LUV)	Bad Not Connected
Value	R/W	Setting: 0: Off / 1: On	Off
REV_FLOW1 Reverse Flow 1	R/W	Indicates reverse flow when true.	-
Status	R/W	Setting: Good Non Cascade / Good Cascade / Uncertain / Bad Not Connected / Bad / Bad No Comm with Last Useable Value (LUV)	Bad Not Connected

Parameter DD name	Access	Description and settings	Initial Value
Value	R/W	Setting: 0: Forward / 1: Reverse	Forward
REV_FLOW2 Reverse Flow 2	R/W	Indicates reverse flow when true.	-
Status	R/W	Setting: Good Non Cascade / Good Cascade / Uncertain / Bad Not Connected / Bad / Bad No Comm with Last Useable Value (LUV)	Bad Not Connected
Value	R/W	Setting: 0: Forward / 1: Reverse	Forward
RTOTAL Rejected Total	R/W	Indicates the Totalization of BAD or BAD + UNCERTAIN Inputs, according to INTEG_OPTS.	0.0
SRTOTAL Snapshot of Rejected Total	R	The snapshot of RTOTAL, just before a reset.	0.0
SSP Snapshot of Setpoint	R	The snapshot of TOTAL_SP.	0.0
STATUS_OPTS Status Option	R/W	Options which the user may select in the block processing of status. Setting: Uncertain if Man	Uninitialized
STOTAL Snapshot of Total	R	Indicates the Snapshot of OUT just before a reset.	0.0
TIME_UNIT1 Time Unit 1	R/W	Converts the rate time units in seconds. Setting: 1: seconds / 2: minutes / 3: hour / 4: days	Uninitialized
TIME_UNIT2 Time Unit 2	R/W	Converts the rate time units in seconds. Setting: 1: seconds / 2: minutes / 3: hour / 4: days	Uninitialized
TOTAL_SP Total Setpoint	R/W	The SP for a batch totalization. Not just SP because SP has PV units and other special properties not used in this application. Setting: Positive or 0	0
UNIT_CONV Unit Conversion	R/W	Factor to convert the engineering units of input 2 into the engineering units of input 1. Setting: Positive or not 0	1.0
UPDATE_EVT Update Event	R	This alert is generated by any change to the static data.	-
Unacknowledged	R	A discrete enumeration which is set to "Unacknowledged" when an alarm occurs, and set to "Acknowledged" by a write from a human interface device or other entity which can acknowledge that the alarm/event has been noticed. Setting: Uninitialized / Acknowledged / Unacknowledged	Uninitialized
Update State	R	A discrete enumeration which gives an indication of whether the alert is active and whether it has been reported. Setting: Uninitialized / Acknowledged / Unacknowledged	Uninitialized

Parameter DD name	Access	Description and settings	Initial Value
Time Stamp	R	<p>The time when evaluation of the block was started and a change in alarm/event state was detected that is unreported. The time stamp value will be maintained constant until alert confirmation has been received - even if another change of state occurs. Time stamp records the time when parameter was updated.</p> <p>Setting: MM / DD / YY (Month / Day / Year) HH:MM:SS (Hour:Minute:Second)</p>	Uninitialized
Static Revision	R	The static revision of the block whose static parameter was changed and is being reported. It is possible for the present value of static revision to be greater than this because static can be changed at any time.	0
Relative Index	R	The OD index of the static parameter whose change caused this alert, minus the FB starting index. If the update event was caused by a write to multiple parameters at the same time, then this attribute will be zero.	0

4.9 Proportional Integral Derivative Block (PID)

The following tables list the PID Block parameters in alphabetical order.

The following tables contain short parameter description, factory settings (Initial Value (IV)) and possible settings.

Parameter DD name	Access	Description and settings	Initial Value
ALERT_KEY Alert Key	R/W	The identification number of the plant unit. This information may be used in the host for sorting alarms, etc. Setting: 1...255	1
BLOCK_ERR Block Error	R	This parameter reflects the error status associated with the hardware or software components associated with a block. It is a bit string, so that multiple errors may be shown. Setting: <ul style="list-style-type: none"> • Other: Non-specific error active • Block Configuration: Error detected in block configuration • Simulation Active: Simulation enabled in this block • Local Override: Output tracking of faultstate active • Device Fault State: Device faultstate set • Device Maintenance: Device needs maintenance soon • Input Failure: Process variable has bad status • Output Failure: Failure detected in output hardware • Memory Failure: Memory error detected • Lost Static Data: Static parameters cannot be recovered • Lost NV Data: Non-volatile parameters cannot be recovered • Readback Check: Failure detected in READBACK • Maintenance Needed: Device NEEDS maintenance NOW • Power Up: Recovery from power failure • Out Of Service: Block actual mode is out of service 	Current Block Error
MODE_BLK Block Mode	Mix	The actual, target, permitted and normal modes of the block.	-
TARGET Target	R/W	This is the mode requested by the operator. Only one mode from those allowed by the permitted mode parameter may be requested. Setting: ROut / RCas / Cas / Auto / Man / OOS	OOS
ACTUAL Actual	R	This is the current mode of the block, which may differ from the target based on operating conditions. Its value is calculated as part of block execution. Setting: ROut / RCas / Cas / Auto / Man / OOS	Actual mode
PERMITTED Permitted	R/W	Defines the modes which are allowed for an instance of the block. The permitted mode is configured based on application requirement. Setting: ROut / RCas / Cas / Auto / Man / OOS	ROut, RCas, Cas, Auto, Man or OOS
NORMAL Normal	R/W	This is the mode the block should be set to during normal operating conditions. Setting: Auto	Auto

Parameter DD name	Access	Description and settings	Initial Value
ST_REV Static Revision	R	The revision level of the static data associated with the function block. The revision value will be incremented each time a static parameter value in the block is changed.	0
		Setting: 0...65535	
STRATEGY Strategy	R/W	This parameter can be used to create groups of blocks by control system. This data is not checked or processed by the block.	0 (=uninitialized)
		Setting: 0...65535	
TAG_DESC Tag Description	R/W	The user description of the intended application of the block.	spaces
		Setting: ≤32 digits	
ACK_OPTION Acknowledge Option	R/W	Selection of whether alarms associated with the function block will be automatically acknowledged.	No option selected
		Setting: <ul style="list-style-type: none"> • HiHi Alm Disabled: HiHi alarm disabled • Hi Alm Disabled: Hi alarm disabled • LoLo Alm Disabled: LoLo alarm disabled • Lo Alm Disabled: Lo alarm disabled • DevHi Alm Disabled: Deviation Hi alarm disabled • DevLo Alm Disabled: Deviation Lo alarm disabled • Block Alm Disabled: Block alarm disabled 	
ALARM_HYS Alarm Hysteresis	R/W	Amount the PV must return within the alarm limits before the alarm condition clears. Alarm hysteresis expressed as a percent of the span of the PV.	0.5
		Setting: 0.0...50.0%	
ALARM_SUM Alarm Summary	Mix	The current alert status, unacknowledged states, unreported states and disabled states of the alarms associated with the function block.	-
Current	R	Setting: HiHi Alm Active / Hi Alm Active / LoLo Alm Active / Lo Alm Active / DevHi Alarm Active / DevLo Alm Active / Block Alm Active	Uninitialized
Unacknowledged	R	Setting: HiHi Alm Unack / Hi Alm Unack / LoLo Alm Unack / Lo Alm Unack / DevHi Alarm Unack / DevLo Alm Unack / Block Alm Unack	Uninitialized
Unreported	R	Setting: HiHi Alm Unrep / Hi Alm Unrep / LoLo Alm Unrep / Lo Alm Unrep / DevHi Alarm Unrep / DevLo Alm Unrep / Block Alm Unrep	Uninitialized
Disabled	R	Setting: HiHi Alm Disabled / Hi Alm Disabled / LoLo Alm Disabled / Lo Alm Disabled / DevHi Alarm Disabled / DevLo Alm Disabled / Block Alm Disabled	Uninitialized
BAL_TIME Balance Time	R/W	This specifies the time for the internal working value of bias or ratio to return to the operator set bias or ratio, in seconds. In the PID block, it may be used to specify the time constant at which the integral term will move to obtain balance when the output is limited and the mode is Auto, Cas or RCas.	0
		Setting: 0.0 s	

Parameter DD name	Access	Description and settings	Initial Value
BKCAL_HYS Back Calculation Hysteresis	R/W	Limits the minimum output value for modes other than "Manual". The limit status is turned off, expressed as a percent of the span of the output.	0.5
		Setting: 0.0...50.0%	
BKCAL_IN Back Calculation Input	R/W	The value and status used for backwards tracking of the output, provided by a link to the back calculation output parameter of a downstream block.	-
Status	R/W	Status of BKCAL_IN	-
Value	R/W	Value of BKCAL_IN	-
BKCAL_IN Back Calculation Input	R	The output value and status provided to an upstream block for output tracking when the loop is broken or limited, as determined by the status bits. This information is used to provide bumpless transfer to closed loop control and to prevent windup under limited conditions when that becomes possible.	-
		Status	
Value	R	Value of BKCAL_OUT	-
BLOCK_ALM Block Alarm	R/W	The block alarm is used for all configuration, hardware, connection failure or system problems in the block. The cause of the alert is entered in the subcode field. The first alert to become active will set the "Active" status in the "Status" attribute. As soon as the "Unreported" status is cleared by the alert reporting task, another block alert may be reported without clearing the "Active" status, if the subcode has changed.	-
Unacknowledged	R/W	A discrete enumeration which is set to "Unacknowledged" when an alarm occurs, and set to "Acknowledged" by a write from a human interface device or other entity which can acknowledge that the alarm/event has been noticed.	Uninitialized
		Setting: Uninitialized / Acknowledged / Unacknowledged	
Alarm State	R	A discrete enumeration which gives an indication of whether the alert is active and whether it has been reported.	Uninitialized
		Setting: <ul style="list-style-type: none"> • Uninitialized • Clear - reported: Alarm not active and reported • Clear - not reported: Alarm not active and not reported • Active - reported: Alarm active and reported • Active - not reported: Alarm active and not reported 	
Time Stamp	R	The time when evaluation of the block was started and a change in alarm/event state was detected that is unreported. The time stamp value will be maintained constant until alert confirmation has been received - even if another change of state occurs.	Uninitialized
		Setting: MM / DD / YY (Month / Day / Year) HH:MM:SS (Hour:Minute:Second)	

Parameter DD name	Access	Description and settings	Initial Value
Subcode	R	An enumeration specifying the cause of the alert to be reported. Setting: <ul style="list-style-type: none"> • Other: Non-specific error active • BlockConfiguration: Error detected in block configuration • LinkConfiguration: Error detected in link configuration • SimulationActive: Simulation enabled in this block • LocalOverride: Output tracking or faultstate active • DeviceFaultState: DeviceFaultState • DeviceMaintenance: Device needs maintenance soon • InputFailure: Process variable has bad status • OutputFailure: Failure detected in output hardware • MemoryFailure: Memory error detected • LostStaticData: Static parameters cannot be recovered • LostNVData: Non-Volatile parameters cannot be recovered • ReadbackCheck: Failure detected in READBACK • MaintenanceNeeded: Device NEEDS maintenance NOW • PowerUp: Recovery from power failure • OutOfService: Block actual mode is Out of Service 	Other
Value	R	The value of the associated parameter at the time the alert was detected. Setting: 0...255	0
BYPASS Bypass	R/W	The normal control algorithm may be bypassed through this parameter. When bypass is set, the setpoint value (in percent) will be directly transferred to the output. To prevent a bump on transfer to/from bypass, the setpoint will automatically be initialized to the output value or process variable, respectively, and the path broken flag will be set for one execution. Setting: <ul style="list-style-type: none"> • ON: normal control algorithm bypassed, output based on setpoint • OFF: normal control 	Uninitialized
CAS_IN Cascade Input	R/W	This parameter is the remote setpoint value, which must come from another Fieldbus block or a DCS block through a defined link.	-
Status	R/W	Status of CAS_IN	-
Value	R/W	Value of CAS_IN	-

Parameter DD name	Access	Description and settings	Initial Value
CONTROL_OPTS Control Options	R/W	Options which the user may select to alter the calculations done in a control block. Setting: <ul style="list-style-type: none"> • Bypass Enable: This parameter, if true, allows BYPASS to be set. Some control algorithms cannot provide closed loop control if bypassed. • SP-PV Track Man: Permits the setpoint to track the process variable when the block mode is "Man". • SP-PV Track ROut: Permits the setpoint to track the process variable when the block mode is "ROut". • SP-PV Track LO-IMan: Permits the setpoint to track the process variable when the block mode is "LO or IMan". • SP Track retain: Permits the setpoint to track the RCas or Cas parameter based on the retained target mode when the actual mode of the block is "Man, LO, Man, or Rout". • Direct acting: Defines the relationship between changes in PV and changes to output - when direct is selected, an increase in PV results in an increase in the output. • Track enable: This enables the external tracking function – when TRK_ENA is 1, the preset value in TRK_VAL is output if TRK_IN_D becomes true. • Track in manual: This is used only if TRK_ENA is YES (1) - when the block mode is Man, TRK_IN_D will be acted on only if the TRK_OVMAN control option is set. • PV for BKCaL_Out: The BKCAL_OUT value may be selected as the working SP or the PV - normally, BKCAL_OUT is the working SP. • Restrict SP to limits in Cas and RCas: If this option is selected, the setpoint will be restricted to the setpoint absolute and rate limits in Cas and Rcas modes. • No output limits in Man: Do not apply OUT_HI_LIM or OUT_LO_LIM when target and actual modes are "Man". 	No option selected
DV_HI_ALM Deviation High Alarm	Mix	The status and time stamp associated with the high deviation alarm.	-
Unacknowledged	R/W	A discrete enumeration which is set to "Unacknowledged" when an alarm occurs, and set to "Acknowledged" by a write from a human interface device or other entity which can acknowledge that the alarm/event has been noticed. Setting: Uninitialized / Acknowledged / Unacknowledged	Uninitialized
Alarm State	R	A discrete enumeration which gives an indication of whether the alert is active and whether it has been reported. Setting: <ul style="list-style-type: none"> • Uninitialized • Clear - reported: Alarm not active and reported • Clear - not reported: Alarm not active and not reported • Active - reported: Alarm active and reported • Active - not reported: Alarm active and not reported 	Uninitialized
Time Stamp	R	The time when evaluation of the block was started and a change in alarm/event state was detected that is unreported. The time stamp value will be maintained constant until alert confirmation has been received - even if another change of state occurs. Setting: MM / DD / YY (Month / Day / Year) HH:MM:SS (Hour:Minute:Second)	Uninitialized

Parameter DD name	Access	Description and settings	Initial Value
Subcode	R	An enumeration specifying the cause of the alert to be reported.	Other
		Setting: Settings see above parameter "BLOCK_ALM", subelement "Subcode".	
Value	R	The value of the associated parameter at the time the alert was detected.	0
		Setting: 0...255	
DV_HI_LIM Deviation High Limit	R/W	The setting of the high deviation alarm limit in engineering units.	+INF
DV_HI_PRI Deviation High Priority	R/W	Priority of the high deviation alarm.	0
		Setting: 0...15	
DV_LO_ALM Deviation Low Alarm	Mix	The status and time stamp associated with the low deviation alarm.	-
Unacknowledged	R/W	A discrete enumeration which is set to "Unacknowledged" when an alarm occurs, and set to "Acknowledged" by a write from a human interface device or other entity which can acknowledge that the alarm/event has been noticed.	Uninitialized
		Setting: Uninitialized / Acknowledged / Unacknowledged	
Alarm State	R	A discrete enumeration which gives an indication of whether the alert is active and whether it has been reported.	Uninitialized
		Setting: <ul style="list-style-type: none"> • Uninitialized • Clear - reported: Alarm not active and reported • Clear - not reported: Alarm not active and not reported • Active - reported: Alarm active and reported • Active - not reported: Alarm active and not reported 	
Time Stamp	R	The time when evaluation of the block was started and a change in alarm/event state was detected that is unreported. The time stamp value will be maintained constant until alert confirmation has been received - even if another change of state occurs.	Uninitialized
		Setting: MM / DD / YY (Month / Day / Year) HH:MM:SS (Hour:Minute:Second)	
Subcode	R	An enumeration specifying the cause of the alert to be reported.	Other
		Setting: Settings see above parameter "BLOCK_ALM", subelement "Subcode".	
Value	R	The value of the associated parameter at the time the alert was detected.	0
		Setting: 0...255	
DV_LO_LIM Deviation Low Limit	R/W	The setting of the low deviation alarm limit in engineering units.	-INF
DV_LO_PRI Deviation Low Priority	R/W	Priority of the low deviation alarm.	0
		Setting: 0...15	

Parameter DD name	Access	Description and settings	Initial Value
FF_GAIN Feed Forward Gain	R/W	The gain that the feed forward input is multiplied by before it is added to the calculated control output.	0
FF_SCALE Feed Forward Scale	R/W	The feed forward input high and low scale values, engineering units code and number of digits to the right of the decimal point.	-
EU at 100%	R/W	The engineering unit value which represents the upper end of range of the associated block parameter.	100
EU at 0%	R/W	The engineering unit value which represents the lower end of range of the associated block parameter.	0
Units Index	R/W	Device Description units code index for the engineering unit descriptor for the associated block value. Setting: All units are possible.	Uninitialized
FF_VAL Feed Forward Value	R	The feed forward value and status.	-
Status	R	Status of FF_VAL	-
Value	R	Value of FF_VAL	-
GAIN Gain	R/W	Dimensionless value used by the block algorithm in calculating the block output.	0
GRANT_DENY Grant Deny	R/W	Options for controlling access of host computers and local control panels to operating, tuning and alarm parameters of the block.	-
Grant	R/W	Depending on the philosophy of the plant, the operator or a higher level device (HLD), or a local operator's panel (LOP) in the case of Local, may turn on an item of the Grant attribute - Program, Tuning, Alarm or Local. Setting: <ul style="list-style-type: none"> • Program: Host may change mode, setpoint or output of block • Tune: Host may change the tuning parameters of block • Alarm: Host may change the alarm parameters of block • Local: A local panel or handheld device may change the target mode, setpoint or output 	No option selected
Deny	R/W	The "Denied" attribute is provided for use by a monitoring application in an interface device and may not be changed by an operator. Setting: <ul style="list-style-type: none"> • Program denied: Granting of program permission has been reset • Tune denied: Granting of tune permission has been reset • Alarm denied: Granting of alarm permission has been reset • Local denied: Granting of local permission has been reset 	No option selected
HI_ALM High Alarm	Mix	The status for High Alarm and its associated time stamp.	-
Unacknowledged	R/W	A discrete enumeration which is set to "Unacknowledged" when an alarm occurs, and set to "Acknowledged" by a write from a human interface device or other entity which can acknowledge that the alarm/event has been noticed. Setting: Uninitialized / Acknowledged / Unacknowledged	Uninitialized

Parameter DD name	Access	Description and settings	Initial Value
Alarm State	R	A discrete enumeration which gives an indication of whether the alert is active and whether it has been reported. Setting: <ul style="list-style-type: none"> • Uninitialized • Clear - reported: Alarm not active and reported • Clear - not reported: Alarm not active and not reported • Active - reported: Alarm active and reported • Active - not reported: Alarm active and not reported 	Uninitialized
Time Stamp	R	The time when evaluation of the block was started and a change in alarm/event state was detected that is unreported. The time stamp value will be maintained constant until alert confirmation has been received - even if another change of state occurs. Setting: MM / DD / YY (Month / Day / Year) HH:MM:SS (Hour:Minute:Second)	Uninitialized
Subcode	R	An enumeration specifying the cause of the alert to be reported. Setting: Settings see above parameter "BLOCK_ALM", subelement "Subcode".	Other
Value	R	The value of the associated parameter at the time the alert was detected.	0
HI_HI_ALM High High Alarm	Mix	The status for High High Alarm and its associated time stamp.	-
Unacknowledged	R/W	A discrete enumeration which is set to "Unacknowledged" when an alarm occurs, and set to "Acknowledged" by a write from a human interface device or other entity which can acknowledge that the alarm/event has been noticed. Setting: Uninitialized / Acknowledged / Unacknowledged	Uninitialized
Alarm State	R	A discrete enumeration which gives an indication of whether the alert is active and whether it has been reported. Setting: <ul style="list-style-type: none"> • Uninitialized • Clear - reported: Alarm not active and reported • Clear - not reported: Alarm not active and not reported • Active - reported: Alarm active and reported • Active - not reported: Alarm active and not reported 	Uninitialized
Time Stamp	R	The time when evaluation of the block was started and a change in alarm/event state was detected that is unreported. The time stamp value will be maintained constant until alert confirmation has been received - even if another change of state occurs. Setting: MM / DD / YY (Month / Day / Year) HH:MM:SS (Hour:Minute:Second)	Uninitialized
Subcode	R	An enumeration specifying the cause of the alert to be reported. Setting: Settings see above parameter "BLOCK_ALM", subelement "Subcode".	Other
Value	R	The value of the associated parameter at the time the alert was detected.	0

Parameter DD name	Access	Description and settings	Initial Value
HI_HI_LIM High High Limit	R/W	The setting for High High Alarm in engineering units.	+INF
HI_HI_PRI High High Priority	R/W	Priority of the High High Alarm.	0
		Setting: 0...15	
HI_LIM High Limit	R/W	The High Limit imposed on the PV compensation term.	+INF
HI_PRI High Priority	R/W	Priority of the High Alarm.	0
		Setting: 0...15	
IN Input	R/W	Primary input value of the block, required for blocks that filter the input to get the PV.	-
Status	R/W	Status of IN	-
Value	R/W	Value of IN	-
LO_ALM Low Alarm	Mix	The status for Low Alarm and its associated time stamp.	-
Unacknowledged	R/W	A discrete enumeration which is set to "Unacknowledged" when an alarm occurs, and set to "Acknowledged" by a write from a human interface device or other entity which can acknowledge that the alarm/event has been noticed.	Uninitialized
		Setting: Uninitialized / Acknowledged / Unacknowledged	
Alarm State	R	A discrete enumeration which gives an indication of whether the alert is active and whether it has been reported.	Uninitialized
		Setting: <ul style="list-style-type: none"> • Uninitialized • Clear - reported: Alarm not active and reported • Clear - not reported: Alarm not active and not reported • Active - reported: Alarm active and reported • Active - not reported: Alarm active and not reported 	
Time Stamp	R	The time when evaluation of the block was started and a change in alarm/event state was detected that is unreported. The time stamp value will be maintained constant until alert confirmation has been received - even if another change of state occurs.	Uninitialized
		Setting: MM / DD / YY (Month / Day / Year) HH:MM:SS (Hour:Minute:Second)	
Subcode	R	An enumeration specifying the cause of the alert to be reported.	Other
		Setting: Settings see above parameter "BLOCK_ALM", subelement "Subcode".	
Value	R	The value of the associated parameter at the time the alert was detected.	0
LO_LIM Low Limit	R/W	The setting for Low Alarm in engineering units.	-INF
LO_LO_ALM Low Low Alarm	Mix	The status of the Low Low Alarm and its associated time stamp.	-

Parameter DD name	Access	Description and settings	Initial Value
Unacknowledged	R/W	A discrete enumeration which is set to "Unacknowledged" when an alarm occurs, and set to "Acknowledged" by a write from a human interface device or other entity which can acknowledge that the alarm/event has been noticed. Setting: Uninitialized / Acknowledged / Unacknowledged	Uninitialized
Alarm State	R	A discrete enumeration which gives an indication of whether the alert is active and whether it has been reported. Setting: <ul style="list-style-type: none"> • Uninitialized • Clear - reported: Alarm not active and reported • Clear - not reported: Alarm not active and not reported • Active - reported: Alarm active and reported • Active - not reported: Alarm active and not reported 	Uninitialized
Time Stamp	R	The time when evaluation of the block was started and a change in alarm/event state was detected that is unreported. The time stamp value will be maintained constant until alert confirmation has been received - even if another change of state occurs. Setting: MM / DD / YY (Month / Day / Year) HH:MM:SS (Hour:Minute:Second)	Uninitialized
Subcode	R	An enumeration specifying the cause of the alert to be reported. Setting: Settings see above parameter "BLOCK_ALM", subelement "Subcode".	Other
Value	R	The value of the associated parameter at the time the alert was detected.	0
LO_LO_LIM Low Low Limit	R/W	The setting for Low Low Alarm in engineering units.	-INF
LO_LO_PRI Low Low Priority	R/W	Priority of the Low Low Alarm. Setting: 0...15	0
LO_PRI Low Priority	R/W	Priority of the Low Alarm. Setting: Max. 15	1
OUT Output	Mix	The primary analog value calculated as a result of executing the function block.	-
Status	R/W	Status of OUT	-
Value	R/W	Value of OUT	-
OUT_HI_LIM Output High Limit	R/W	Limits the maximum output value for modes other than "Manual".	100
OUT_LO_LIM Output Low Limit	R/W	Limits the minimum output value for modes other than "Manual".	0
OUT_SCALE Output Scale	R/W	The high and low scale values, engineering units code and number of digits to the right of the decimal point to be used in displaying the OUT parameter and parameters which have the same scaling as OUT.	-
EU at 100%	R/W	The engineering unit value which represents the upper end of range of the associated block parameter.	100
EU at 0%	R/W	The engineering unit value which represents the lower end of range of the associated block parameter.	0

Parameter DD name	Access	Description and settings	Initial Value
Units Index	R/W	Device Description units code index for the engineering unit descriptor for the associated block value.	Uninitialized
		Setting: All units are possible.	
Decimal Point	R/W	The number of digits to the right of the decimal point which should be used by an interface device in displaying the specified parameter.	0
PV Process Value	R	This alert is generated by any change to the static data.	-
Status	R	Status of PV	-
Value	R	Value of PV	-
PV_FT PV F Time (Process Value Filter Time Constant)	R/W	Time constant of a single exponential filter for the PV, in seconds.	0
		Setting: 0.0...30.0	
PV_SCALE Process Value Scale	R/W	The high and low scale values, engineering units code and number of digits to the right of the decimal point to be used in displaying the PV parameter and parameters which have the same scaling as PV.	-
EU at 100%	R/W	The engineering unit value which represents the upper end of range of the associated block parameter.	100
EU at 0%	R/W	The engineering unit value which represents the lower end of range of the associated block parameter.	0
Units Index	R/W	Device Description units code index for the engineering unit descriptor for the associated block value.	Uninitialized
		Setting: All units are possible.	
Decimal Point	R/W	The number of digits to the right of the decimal point which should be used by an interface device in displaying the specified parameter.	0
RATE Rate	R/W	Defines the derivative time constant, in seconds.	0
RCAS_IN Remote Cascade Input	R	Target setpoint and status provided by a supervisory host to a analog control or output block.	-
Status	R	Status of RCAS_IN	-
Value	R	Value of RCAS_IN	-
RCAS_OUT Remote Cascade Output	R	Block setpoint and status after ramping - provided to a supervisory host for back calculation and to allow action to be taken under limiting conditions or mode change.	-
Status	R	Status of RCAS_OUT	-
Value	R	Value of RCAS_OUT	-
RESET Reset	R/W	The integral time constant, in seconds per repeat.	+INF
ROUT_IN Remote Out Input	R	Target output and status provided by a host to the control block for use as the output (ROut mode).	-
Status	R	Status of ROUT_IN	-
Value	R	Value of ROUT_IN	-
ROUT_OUT Remote Out Output	R	Block output and status - provided to a host for back calculation in ROut mode and to allow action to be taken under limited conditions or mode change.	-
Status	R	Status of ROUT_OUT	-

Parameter DD name	Access	Description and settings	Initial Value
Value	R	Value of ROUT_OUT	-
SHED_OPT Shed Options	R/W	<p>Defines action to be taken on remote control device timeout.</p> <p>Setting:</p> <ul style="list-style-type: none"> • Uninitialized • NormalShed_NormalReturn: Actual mode changes to next lowest priority non-remote mode permitted, but returns to target remote mode after communications are re-established • NormalShed_NoReturn: Target mode changes to next lowest priority non-remote mode permitted • ShedToAuto_NormalReturn: Actual mode changes to "Auto", but returns to target remote mode after communications are re-established • ShedToAuto_NoReturn: Target mode changes to "Auto" • ShedToManual_NormalReturn: Actual mode changes to "Manual", but returns to target remote mode after communications are re-established • NormalShed_NoReturn: Target mode changes to next lowest priority non-remote mode permitted • ShedToRetainedTarget_NormalReturn: Shed to previous target mode and return target remote mode after communications are re-established • ShedToRetainedTarget_NoReturn: Target mode changes to target retained mode 	Uninitialized
SP Setpoint	R/W	Setpoint	0
Status		Status of SP	
Value		Value of SP	
SP_HI_LIM Setpoint High Limit	R/W	The setpoint high limit is the highest setpoint operator entry that can be used for the block.	100
SP_LO_LIM Setpoint Low Limit	R/W	The setpoint low limit is the highest setpoint operator entry that can be used for the block.	0
SP_RATE_DN Setpoint Rate Down	R/W	<p>Ramp rate at which downward setpoint changes are acted on in "Auto" mode, in PV units per second. If the ramp rate is set to zero or the block is in a mode other than "Auto", then the setpoint will be used immediately.</p> <p>Setting: 0.0...+INF</p>	+INF
SP_RATE_UP Setpoint Rate Up	R/W	<p>Ramp rate at which upward setpoint changes are acted on in "Auto" mode, in PV units per second. If the ramp rate is set to zero or the block is in a mode other than "Auto", then the setpoint will be used immediately.</p> <p>Setting: 0.0...+INF</p>	+INF

Parameter DD name	Access	Description and settings	Initial Value
STATUS_OPTS Status Options	R/W	Options which the user may select in the block processing of status. Setting: <ul style="list-style-type: none"> • IFS if Bad IN: Set Initiate Fault State status in OUT if the status of IN is "Bad". • IFS if Bad CAS_IN: Set Initiate Fault State status in OUT if the status of CAS_IN is "Bad". • Use Uncertain as Good: If the status of IN is "Uncertain", treat it as "Good" otherwise treat it as "Bad". • Target to Man if Bad IN: Set the target mode to "Man" if the status of the IN parameter is "Bad". This latches a PID block into the "Man" state of the input ever goes "Bad". • Target to next permitted mode if BAD CAS_IN 	No option selected
TRK_IN_D Tracking Input Discrete	R/W	This discrete input is used to initiate external tracking of the block output to the value specified by TRL_VAL.	-
Status	R/W	Status of TRK_IN_D	-
Value	R/W	Value of TRK_IN_D	-
TRK_SCALE Tracking Scale	R/W	The high and low scale values, engineering units code and number of digits to the right of the decimal point associated with TRK_VAL.	-
EU at 100%	R/W	The engineering unit value which represents the upper end of range of the associated block parameter.	100
EU at 0%	R/W	The engineering unit value which represents the lower end of range of the associated block parameter.	0
Units Index	R/W	Device Description units code index for the engineering unit descriptor for the associated block value. Setting: All units are possible.	Uninitialized
Decimal Point	R/W	The number of digits to the right of the decimal point which should be used by an interface device in displaying the specified parameter.	0
TRK_VALUE Tracking Value	R/W	This input is used as the track value when external tracking is enabled by TRK_IN_D.	-
Status	R/W	Status of TRK_VAL	-
Value	R/W	Value of TRK_VAL	-
UPDATE_EVT Update Event	R	This alert is generated by any change to the static data.	-
Unacknowledged	R	A discrete enumeration which is set to "Unacknowledged" when an alarm occurs, and set to "Acknowledged" by a write from a human interface device or other entity which can acknowledge that the alarm/event has been noticed. Setting: Uninitialized / Acknowledged / Unacknowledged	Uninitialized
Update State	R	A discrete enumeration which gives an indication of whether the alert has been reported. Setting: Uninitialized / Reported / Not Reported	Uninitialized

Parameter DD name	Access	Description and settings	Initial Value
Time Stamp	R	<p>The time when evaluation of the block was started and a change in alarm/event state was detected that is unreported. The time stamp value will be maintained constant until alert confirmation has been received - even if another change of state occurs.</p> <p>Setting: MM / DD / YY (Month / Day / Year) HH:MM:SS (Hour:Minute:Second)</p>	Uninitialized
Static Revision	R	The static revision of the block whose static parameter was changed and is being reported. It is possible for the present value of static revision to be greater than this because static can be changed at any time.	0
Relative Index	R	The OD index of the static parameter whose change caused this alert, minus the FB starting index. If the update event was caused by a write to multiple parameters at the same time, then this attribute will be zero.	0



KROHNE product overview

- Electromagnetic flowmeters
- Variable area flowmeters
- Ultrasonic flowmeters
- Mass flowmeters
- Vortex flowmeters
- Flow controllers
- Level meters
- Temperature meters
- Pressure meters
- Analysis products
- Products and systems for the oil & gas industry
- Measuring systems for the marine industry

Head Office KROHNE Messtechnik GmbH
Ludwig-Krohne-Str. 5
47058 Duisburg (Germany)
Tel.: +49 (0)203 301 0
Fax: +49 (0)203 301 10389
info@krohne.de

The current list of all KROHNE contacts and addresses can be found at:
www.krohne.com

KROHNE