

Operating Instructions

OPTISOUND 3040 C

4 ... 20 mA/HART - four-wire



Variable area flowmeters

Vortex flowmeters

Flow controllers

Electromagnetic flowmeters

Ultrasonic flowmeters

Mass flowmeters

Level measuring instruments

Communications engineering

Engineering systems & solutions

Switches, counters, displays and recorders

Heat metering

Pressure and temperature

Contents

1 About this document

1.1	Function	5
1.2	Target group	5
1.3	Symbolism used	5

2 For your safety

2.1	Authorised personnel	6
2.2	Appropriate use	6
2.3	Warning about misuse	6
2.4	General safety instructions	6
2.5	CE conformity	6
2.6	Compatibility acc. to NAMUR NE 53	7
2.7	Safety information for Ex areas	7

3 Product description

3.1	Configuration	8
3.2	Principle of operation	9
3.3	Adjustment	9
3.4	Storage and transport	9

4 Mounting

4.1	General instructions	11
4.2	Mounting preparations	13
4.3	Mounting information	17

5 Connecting to power supply

5.1	Preparing the connection	23
5.2	Connection procedure	24
5.3	Wiring plans, double chamber housing	25
5.4	Switch on phase	27

6 Setup with the indicating/adjustment module

6.1	Short description	28
6.2	Installation of the indicating/adjustment module	28
6.3	Adjustment system	30
6.4	Setup procedure	31
6.5	Menu schematic	35

7 Maintenance and fault rectification

7.1	Maintenance	38
7.2	Fault rectification	38
7.3	Exchanging the electronics	39
7.4	Instrument repair	40

8 Dismounting	
8.1 Dismounting procedure	41
8.2 Disposal	41
9 Supplement	
9.1 Technical data.	42
9.2 Dimensions	47
9.3 CE declaration of conformity.	50

Supplementary operating instructions manuals



Information:

OPTISOUND 3040 C is available in different versions and is supplied specifically acc. to the order. Depending on the selected version, supplementary operating instructions manuals come with the shipment. The supplementary operating instructions are stated in paragraph "3. *Product description*".

1 About this document

1.1 Function

This operating instructions manual has all the information you need for quick setup and safe operation of OPTISOUND 3040 C. Please read this manual before you start setup.

1.2 Target group

This operating instructions manual is directed to trained personnel. The contents of this manual should be made available to these personnel and put into practice by them.

1.3 Symbolism used



Information, tip, note

This symbol indicates helpful additional information.



Caution, warning, danger

This symbol informs you of a dangerous situation that could occur. Ignoring this cautionary note can impair the person and/or the instrument.



Ex applications

This symbol indicates special instructions for Ex applications.



List

The dot set in front indicates a list with no implied sequence.



Action

This arrow indicates a single action.



Sequence

Numbers set in front indicate successive steps in a procedure.

2 For your safety

2.1 Authorised personnel

All operations described in this operating instructions manual must be carried out only by trained, specialised personnel authorised by the operator. For safety and warranty reasons, any internal work on the instruments must be carried out only by personnel authorised by the manufacturer.

2.2 Appropriate use

OPTISOUND 3040 C is a sensor for continuous level measurement.

2.3 Warning about misuse

Inappropriate or incorrect use of the instrument can give rise to application-specific hazards, e.g. vessel overflow or damage to system components through incorrect mounting or adjustment.

2.4 General safety instructions

OPTISOUND 3040 C is a high-tech instrument requiring the strict observance of standard regulations and guidelines. The user must take note of the safety instructions in this operating instructions manual, the country-specific installation standards (e.g. the VDE regulations in Germany) as well as all prevailing safety regulations and accident prevention rules.

2.5 CE conformity

OPTISOUND 3040 C is in CE conformity with EMC (89/336/EWG) and NSR (73/23/EWG).

Conformity has been judged acc. to the following standards:

- EMC:
 - Emission EN 61326: 1997 (class A)
 - Susceptibility EN 61326: 1997/A1: 1998
- LVD: EN 61010-1: 2001

OPTISOUND 3040 C is designed for industrial use. Hence, conducted as well as radiated interference must be reckoned with, as is customary with a class A instrument acc. to EN 61326. If OPTISOUND 3040 C is used in a different environment, the electromagnetic compatibility to other instruments must be ensured by suitable measures.

2.6 Compatibility acc. to NAMUR NE 53

OPTISOUND 3040 C meets NAMUR recommendation NE 53.

The parameter adjustment of the basic sensor functions is independent of the software version. The range of available functions depends on the respective software version of the individual components.

The software version of OPTISOUND 3040 C can be determined as follows:

- on the type label of the electronics
- via the indicating/adjustment module.

You can find all software histories on our website www.krohne.com.

2.7 Safety information for Ex areas

Please note the Ex-specific safety information for installation and operation in Ex areas. These safety instructions are part of the operating instructions manual and come with the Ex-approved instruments.

3 Product description

3.1 Configuration

Scope of delivery

The scope of delivery encompasses:

- OPTISOUND 3040 C ultrasonic sensor
- Documentation
 - this operating instructions manual
 - Ex-specific safety instructions (with Ex versions) and, if necessary, further certificates
 - Operating instructions manual "*Indicating and adjustment module*" - optional

Components

OPTISOUND 3040 C consists of the following components:

- transducer with process fitting (depending on version flange, swivelling holder or thread)
- housing with electronics (depending on version remote)
- Housing cover, optionally available with indicating/adjustment module

The components are available in different versions:

- Version A: compact in flange version
- Version B: compact with swivelling holder
- Version C: separately with swivelling holder
- Version D: separately with threaded fitting

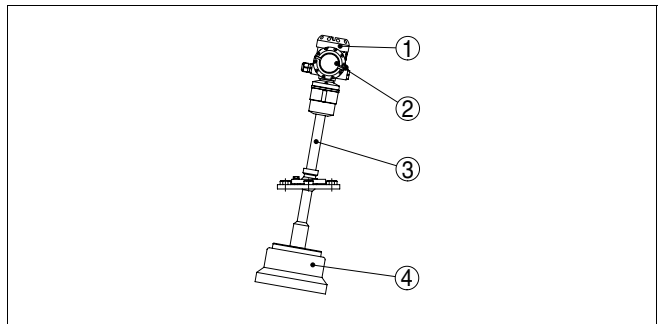

Fig. 1: OPTISOUND 3040 C compact with swivelling holder

- 1 Housing cover, optionally available with indicating/adjustment module
- 2 Housing with electronics
- 3 Swivelling holder with flange
- 4 Transducer

3.2 Principle of operation

Area of application	OPTISOUND 3040 C is an ultrasonic sensor for continuous level measurement. It is particularly suitable for solids, but is also good for liquids.
Physical principle	The transducer of the ultrasonic sensor emits short ultrasonic pulses in the direction of the measured product. These pulses are reflected by the product surface and received by the transducer as echoes. The running time of the ultrasonic pulses from emission to reception is proportional to the distance and hence to the level. The determined level is converted into an appropriate output signal and outputted as measured value.
Power supply	<p>Four-wire electronics with separate power supply.</p> <p>The power supply range can differ depending on the instrument version. The exact range is stated in the "<i>Technical data</i>" in the "<i>Supplement</i>".</p> <p>Measured value transmission is carried out via the 4 ... 20 mA/HART output, which is separated from the power supply.</p>

3.3 Adjustment

OPTISOUND 3040 C can be adjusted with two different adjustment media:

- the indicating/adjustment module
- a HART handheld

The entered parameters are generally saved in OPTISOUND 3040 C, optionally also in the indicating/adjustment module.

3.4 Storage and transport

Packaging	<p>Your instrument was protected by packaging during transport. Its capacity to handle normal loads during transport is assured by a test acc. to DIN EN 24180.</p> <p>The packaging of standard instruments consists of environment-friendly, recyclable cardboard. For special versions, PE foam or PE foil is also used. Dispose of the packaging material via specialised recycling companies.</p>
Storage and transport temperature	<ul style="list-style-type: none"> ● Storage and transport temperature see "<i>Supplement – Technical data – Ambient conditions</i>"

- Relative humidity 20 ... 85 %

4 Mounting

4.1 General instructions

Installation position

Select an installation position you can easily reach for mounting and connecting as well as later retrofitting of an indicating and adjustment module. The housing can be rotated by 330° without the use of any tools. You can also install the indicating and adjustment module in four different positions (each displaced by 90°).

Moisture

Use the recommended cable (see chapter "*Connecting to power supply*") and tighten the cable gland.

You can give your OPTISOUND 3040 C additional protection against moisture penetration by leading the connection cable downward in front of the cable entry. Rain and condensation water can thus drain off. This applies mainly to mounting outdoors, in areas where moisture is expected (e.g. by cleaning processes) or on cooled or heated vessels.

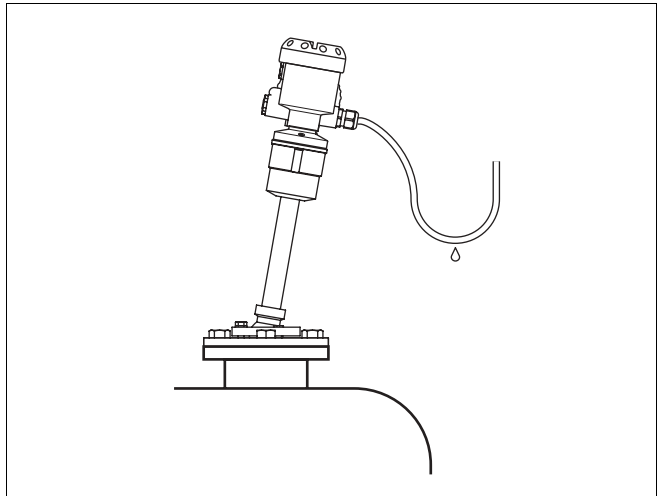

Fig. 2: Measures against moisture penetration

Measuring range

The reference plane for the measuring range (version A) is the lower edge of the flange. The reference plane for versions B, C and D is the lower edge of the transducer.

Make sure that for all versions a min. distance - the so called dead zone - below the reference plane is maintained in which a measurement is not possible. The exact value of the dead zone is stated in the Technical data in the Supplement.



Information:

If the product reaches the transducer, buildup can form on it over a period of time and later cause measurement errors.

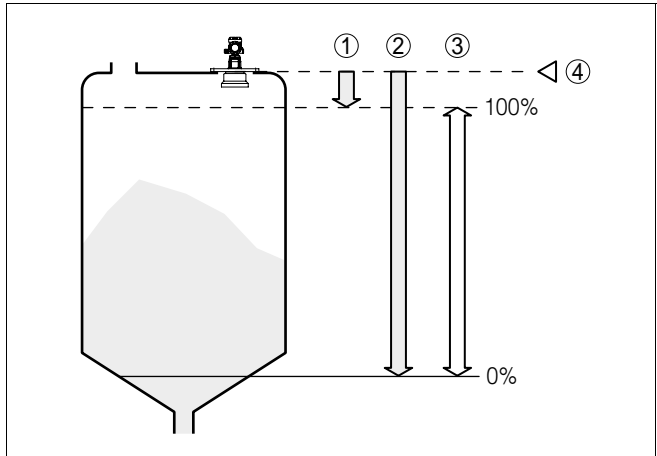

Fig. 3: Version A – Measuring range (operating range) and max. measuring distance

- 1 full (dead zone)
- 2 empty (max. measuring distance)
- 3 Measuring range
- 4 Reference plane

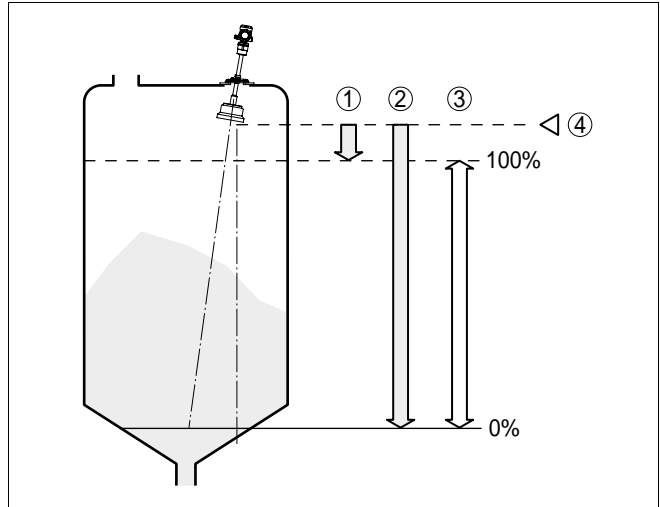

Fig. 4: Version B, C, D – Measuring range (operating range) and max. measuring distance

- 1 full (dead zone)
- 2 empty (max. measuring distance)
- 3 Measuring range
- 4 Reference plane

Pressure/Vacuum

Gauge pressure in the vessel does not influence OPTISOUND 3040 C. Low pressure or vacuum, however, damp the ultrasonic pulses. This influences the measuring result, particularly if the level is very low. With pressures under - 0.2 bar (-20 kPa) you should use a different measuring principle, e.g. radar or guided radar (TDR).

4.2 Mounting preparations

Assembly – version B

Version B is supplied in two parts:

- Transducer
- electronics housing

Assemble the version as follows:

- 1 Loosen the screws on the fixing ring (4) with a hexagon spanner (size 4), remove the transducer tube out of the swivelling holder
- 2 Mount the flange
- 3 Insert the transducer tube in the requested length from below into the swivelling holder
- 4 Fasten with screws (4); torque max. 10 Nm

- 5 Remove the plug from below out of the instrument housing and plug it into the socket of the transducer tube
- 6 Plug the electronics housing to the transducer tube. Do not squeeze any cables. The housing is in the correct position, if the lower notch (2) of the transducer tube is no longer visible
- 7 Tighten the screws (5) on the housing moderately with a hexagon spanner (size 4)
- 8 Loosen the screw of the swivelling holder (3) with a fork spanner (SW 13)
- 9 Direct the sensor with the swivelling holder to the measured product
- 10 Fasten the swivelling holder with screw (3), torque max. 20 Nm
- 11 Secure screw (3) with lacquer or similar to ensure permanent tightness of the swivelling holder
- 12 Rotate the housing in such a way that the cable entry points downwards (moisture can drain off). Fasten the housing with the screws (5); torque Aluminium housing max. 5 Nm, torque plastic housing max. 2 Nm

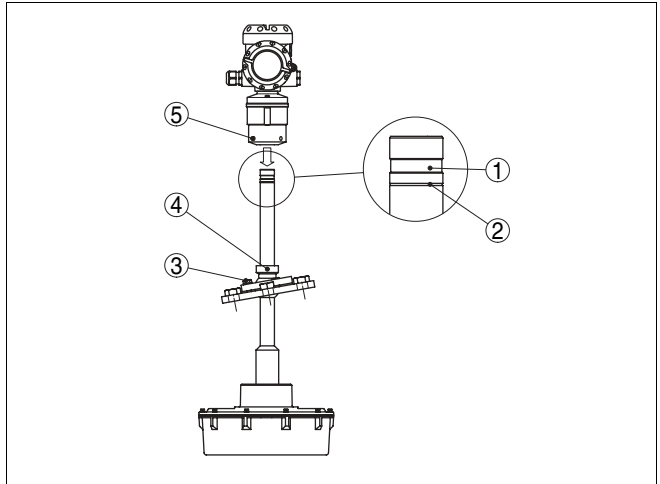

Fig. 5: Assembling – version B

- 1 Groove for locking the housing
- 2 Marking notch
- 3 Screw of swivelling holder (hexagon SW 13)
- 4 Screws of fixing ring (hexagon spanner - size 4)
- 5 Screws of housing (hexagon spanner - size 4)

Assembly – version C

Version C is supplied in three parts:

- Transducer
- Transducer cable
- electronics for wall mounting

Assemble the version as follows:

- 1 Loosen the screws on the fixing ring (4) with a hexagon spanner (size 4), remove the transducer tube out of the swivelling holder
- 2 Mount the flange
- 3 Insert the transducer tube in the requested length from below into the swivelling holder
- 4 Fasten with screws (4); torque max. 10 Nm
- 5 Remove the plug from below out of the connection cylinder and plug it into the socket of the transducer tube
- 6 Plug the connection cylinder to the transducer tube. Do not squeeze any cables. The cylinder is in the correct position, if the lower notch (2) of the transducer tube is no longer visible

- 7 Tighten the screws (5) on the cylinder moderately with a hexagon spanner (size 4)
- 8 Loosen the screw of the swivelling holder (3) with a fork spanner (SW 13)
- 9 Direct the sensor with the swivelling holder to the measured product
- 10 Fasten the swivelling holder with screw (3), torque max. 20 Nm
- 11 Secure screw (3) with lacquer or similar to ensure permanent tightness of the swivelling holder
- 12 Rotate the connection cylinder in such a way that the cable entry points downwards (moisture can drain off). Fasten the cylinder with screws (5); torque max. 5 Nm
- 13 Insert the plug at the end of the transducer cable into the socket on the remote electronics

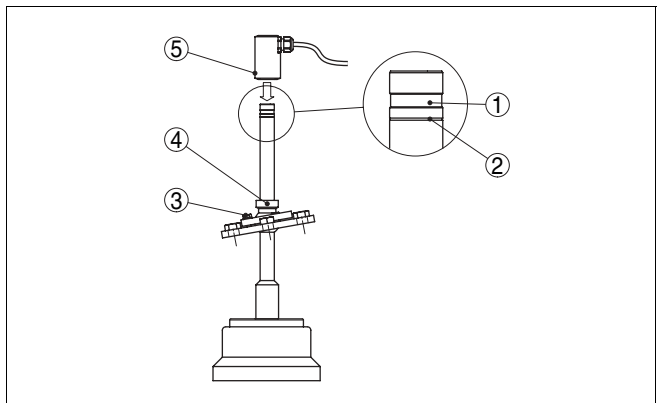

Fig. 6: Assembling – version C

- 1 Groove for locking the connection cylinder
- 2 Marking notch
- 3 Screw of swivelling holder (hexagon SW 13)
- 4 Screws of fixing ring (hexagon spanner - size 4)
- 5 Screws of connection cylinder (hexagon spanner - size 4)

Assembling – version D

Version D is supplied in three parts:

- Transducer
- Transducer cable
- electronics for wall mounting

Assemble the version as follows:

- 1 Loosen the hexagon nut (3) on the transducer cable
- 2 Insert the transducer tube from below into the mounting opening G1A
- 3 Fasten (SW 46) the hexagon nut (3)
- 4 Remove the plug from below out of the connection cylinder and plug it into the socket of the transducer tube
- 5 Plug the connection cylinder to the transducer tube. Do not squeeze any cables. The cylinder is in the correct position, if the lower notch (2) of the transducer tube is no longer visible
- 6 Tighten the screws (4) on the cylinder moderately with a hexagon spanner (size 4)
- 7 Rotate the connection cylinder in such a way that the cable entry points downwards (moisture can drain off). Fasten the cylinder with screws (4); torque max. 5 Nm
- 8 Insert the plug at the end of the transducer cable into the socket on the remote electronics

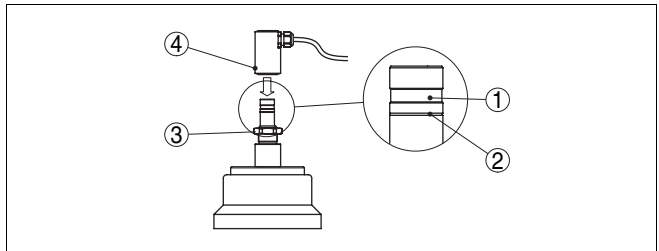

Fig. 7: Assembling – version D

- 1 Groove for locking the connection cylinder
- 2 Marking notch
- 3 Hexagon nut SW 46
- 4 Screws of connection cylinder (hexagon spanner - size 4)

4.3 Mounting information

Installation position

When mounting OPTISOUND 3040 C, keep a distance of at least 500 mm to the vessel wall. If the sensor is installed in the center of concave or arched vessel tops, multiple echoes can arise. These can, however, be faded out by an appropriate adjustment (see chapter "Setup").

If this distance cannot be maintained, a false echo storage should be carried out during setup. This applies particularly if buildup on the vessel wall is expected. In this case, we recommend repeating the false echo storage later on with existing buildup.

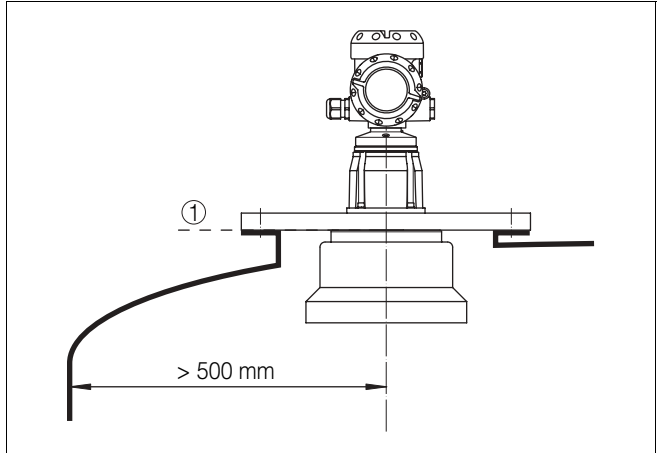

Fig. 8: Installation position
1 Reference plane

In vessels with conical bottom it can be advantageous to align the sensor to the center of the vessel, as measurement is then possible down to the lowest points of the vessel bottom.

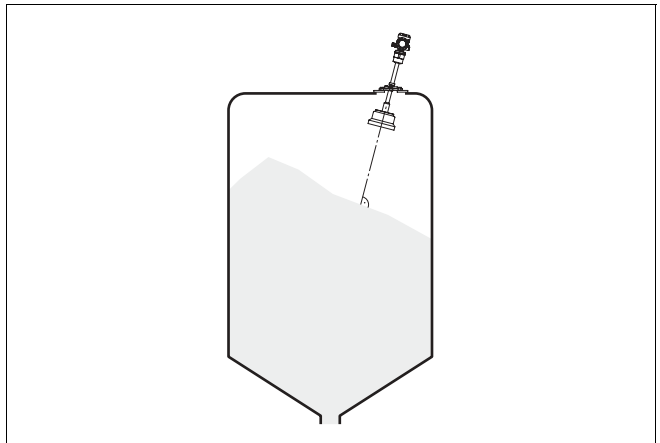

Fig. 9: Vessel with conical bottom

Socket

The transducer should be mounted preferably without socket, flush with the vessel top.

If the reflective properties of the medium are good, you can mount OPTISOUND 3040 C on a socket piece. The socket end should be smooth and burr-free, if possible also rounded. Carry out a false echo storage.

Sensor orientation

In liquids, direct the sensor as perpendicular as possible to the product surface to achieve optimum measurement results.

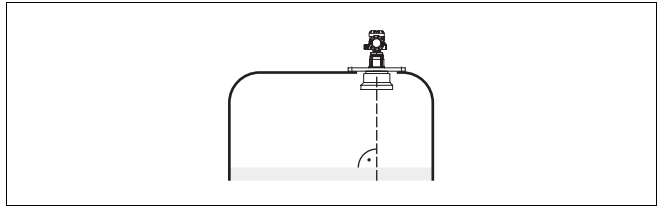

Fig. 10: Orientation in liquids

To optimally align the sensor to solid products, a swivelling holder can be implemented.

Vessel installations

The ultrasonic sensor should be installed at a location where no installations cross the ultrasonic beam.

Vessel installations such as for example, ladders, limit switches, heating spirals, struts etc. can cause false echoes superimposed on the useful echo. Make sure when planning your measuring site that the ultrasonic signals have "free access" to the measured product.

If there are existing vessel installations, a false echo storage should be carried out during setup.

If large vessel installations such as struts or supports cause false echoes, these can be attenuated through supplementary measures. Small, inclined sheet metal or plastic baffles above the installations scatter the ultrasonic signals and avoid direct false echoes.

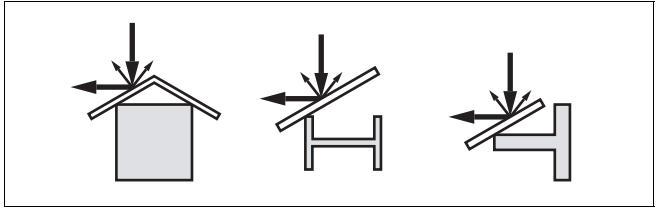

Fig. 11: Cover smooth profiles with deflectors

Agitators

If there are agitators in the vessel, a false echo storage should be carried out with the agitators in motion. This ensures that the interfering reflections from the agitators are saved with the blades in different positions.

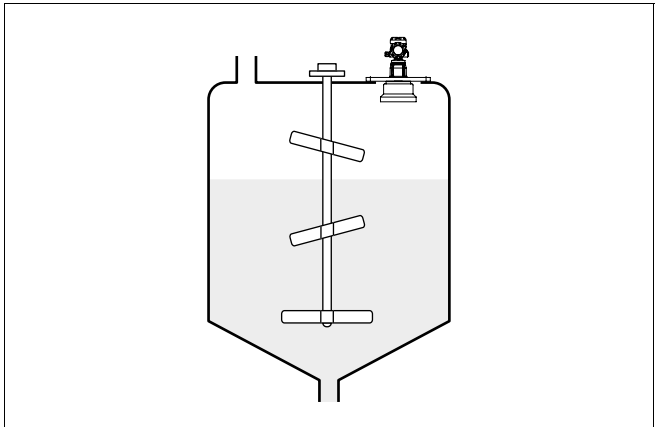

Fig. 12: Agitators

Material heaps

Large material heaps are detected with several instruments, which can be mounted on e.g. traverse cranes. For this type of application, it is best to orient the sensor toward the solid surface.

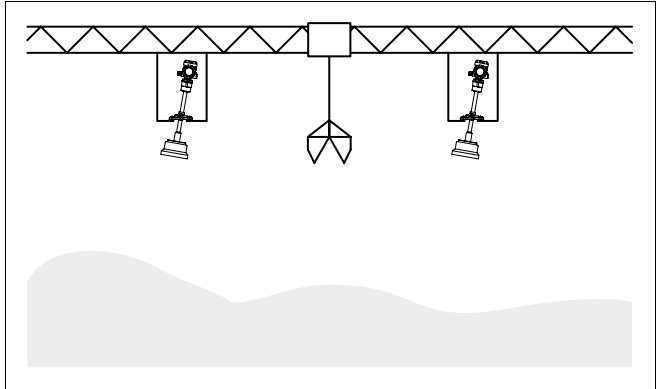

Fig. 13: Transducers on traverse crane

Inflowing material

Do not mount the instruments in or above the filling stream. Make sure that you detect the product surface and not the inflowing product.

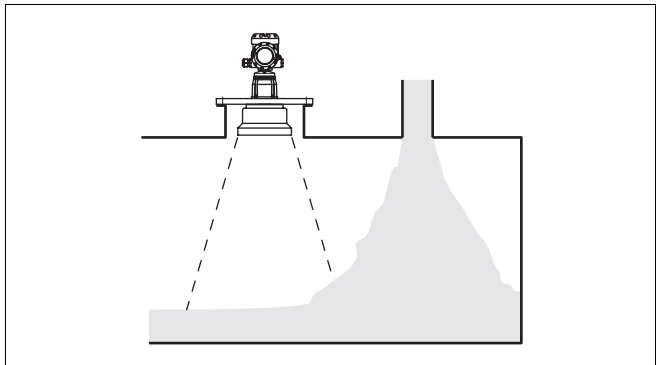

Fig. 14: Inflowing material

Foam

Through the action of filling, stirring and other processes in the vessel, dense foams which considerably damp the emitted signals may form on the product surface.

If foams are causing measurement errors, the sensor should be used in a standpipe or, alternatively, the more suitable guided radar sensors (TDR) should be used.

Guided radar is not influenced by foam generation and is particularly suitable for such applications.

Air flow

If there are strong air currents in the vessel, e.g. due to strong winds in outdoor installations, or because of air turbulence, e.g. through cyclone exhausting, you should mount OPTISOUND 3040 C in a standpipe or use a different measuring principle, e.g. radar or guided radar (TDR).

Heat fluctuations

Strong heat fluctuations, e.g. caused by the sun, can cause measurement errors. In this case, you should use a sun shield.

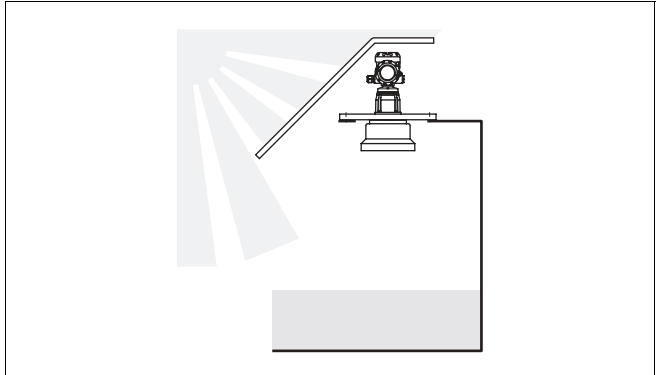

Fig. 15: Heat fluctuations

5 Connecting to power supply

5.1 Preparing the connection

Note safety instructions

Always observe the following safety instructions:

- Connect only in the complete absence of line voltage
- If overvoltages are expected, overvoltage arresters should be installed.

Take note of safety instructions for Ex applications



In hazardous areas you should take note of the appropriate regulations, conformity and type approval certificates of the sensors and power supply units.

Select power supply

Power supply and current output are transmitted via separate two-wire connection cables. The power supply range can differ depending on the instrument version. The exact range is stated in the "*Technical data*" in the Supplement.

The standard version can be operated with an earth-connected current output, the Exd version must be operated with a floating output.

This instrument is designed in protection class I. To maintain this protection class, it is absolutely necessary that the ground conductor be connected to the internal ground terminal. Take note of the general installation regulations.

As a rule, connect OPTISOUND 3040 C to vessel ground (potential equalisation), or in case of plastic vessels, to the next ground potential. There is a ground terminal on the side of the instrument housing.

Selecting the connection cable

For power supply, an approved installation cable with PE conductor is necessary.

The 4 ... 20 mA current output is connected with standard two-wire cable without screen. An outer cable diameter of 5 ... 9 mm ensures the seal effect of the cable entry. If electro-magnetic interference is expected, we recommend the use of screened cable.

Cable screening and grounding

Connect the cable screen on both ends to ground potential. In the sensor, the screen must be connected directly to the internal ground terminal. The ground terminal outside on the housing must be connected to the potential equalisation (low impedance).

If potential equalisation currents are expected, the connection on the evaluation side must be made via a ceramic capacitor (e.g. 1 nF, 1500 V). The low frequency potential equalisation currents are thus suppressed, but the protective effect against high frequency interference signals remains.

Select connection cable for Ex applications



Take note of the corresponding installation regulations for Ex applications. In particular, make sure that no potential equalisation currents flow over the cable screen. In case of grounding on both sides this can be achieved by the use of a capacitor or a separate potential equalisation.

5.2 Connection procedure

Proceed as follows:

- 1 Unscrew the housing cover
- 2 Loosen compression nut of the cable entry
- 3 Remove approx. 10 cm (4 in) of the cable mantle (current output), strip approx. 1 cm (0.4 in) insulation from the ends of the individual wires
- 4 Insert the cable into the sensor through the cable entry
- 5 Lift the opening levers of the terminals with a screwdriver
- 6 Insert the wire ends into the open terminals according to the wiring plan
- 7 Press down the opening levers of the terminals, you will hear the terminal spring closing
- 8 Check the hold of the wires in the terminals by lightly pulling on them
- 9 Connect the screen to the internal ground terminal and the external ground terminal to potential equalisation
- 10 Tighten the compression nut of the cable entry, the seal ring must completely encircle the cable
- 11 Connect the lead cable for power supply in the same way acc. to the wiring plan, in addition connect the ground conductor to the inner ground terminal.
- 12 Screw the housing cover back on

The electrical connection is finished.

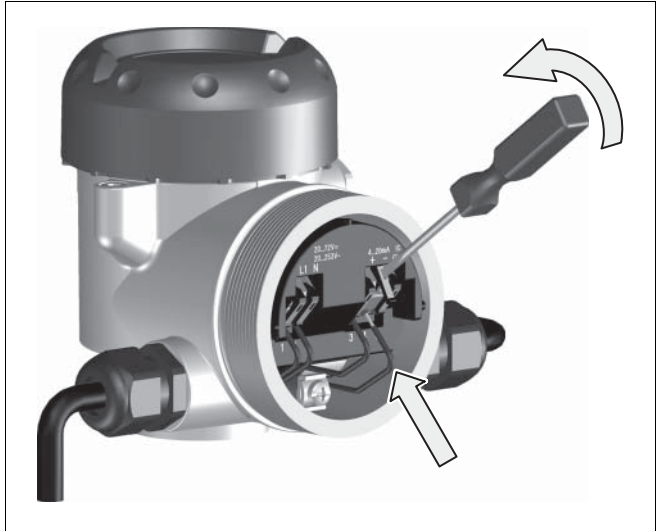

Fig. 16: Connection steps 5 and 6

5.3 Wiring plans, double chamber housing

Housing overview

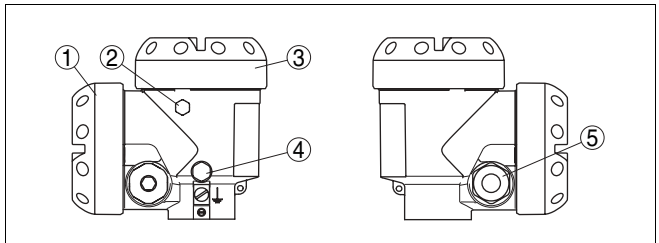
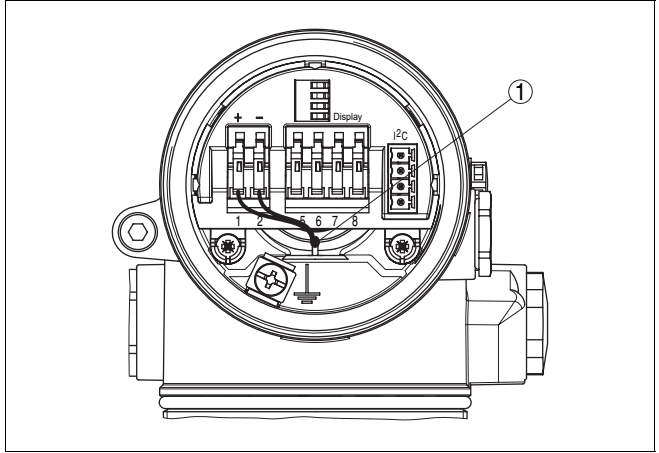

Fig. 17: Double chamber housing

- 1 Housing cover, connection compartment
- 2 Blind stopper
- 3 Housing cover, electronics compartment
- 4 Filter element for pressure compensation
- 5 Cable gland

Electronics compartment



*Fig. 18: Electronics compartment, double chamber housing
1 Internal connection cable to the connection compartment*

Connection compartment

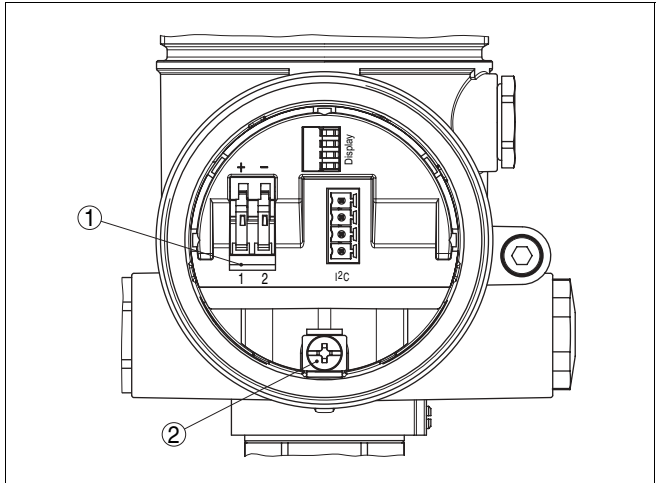

*Fig. 19: Connection compartment, double chamber housing
1 Spring-loaded terminals for power supply
2 Ground terminal for connection of the cable screen*

Wiring plan

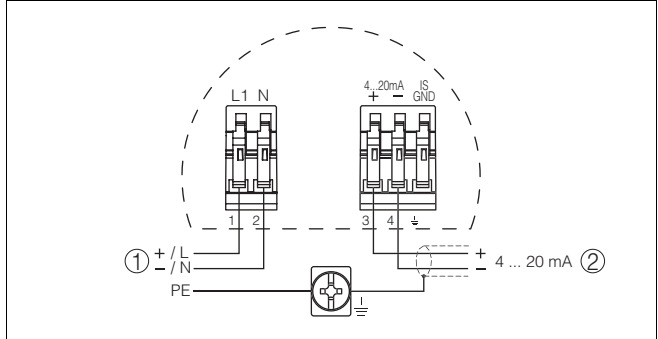

Fig. 20: Wiring plan, double chamber housing

- 1 Supply voltage
- 2 Signal output

5.4 Switch on phase

Switch on phase

After OPTISOUND 3040 C is connected to power supply, the instrument carries out a self-test for approx. 30 seconds. The following steps are carried out:

- Internal check of the electronics
- Indication of the instrument type, the firmware version as well as the sensor TAGs (sensor name)
- Output signal jumps briefly (approx. 10 seconds) to the set fault current

Then the actual measured value is displayed and the corresponding current is transmitted to the cable.¹⁾

¹⁾ The values correspond to the actual level as well as to the settings already carried out, e.g. default setting.

6 Setup with the indicating/adjustment module

6.1 Short description

The indicating/adjustment module is used for measured value display, adjustment and diagnosis. It can be mounted in all sensors of the OPTISOUND instrument family, in the single as well as double chamber housing (optionally in the electronics or connection compartment).

6.2 Installation of the indicating/adjustment module

The indicating/adjustment module can be inserted or removed at any time. It is not necessary to interrupt the power supply.

To mount, proceed as follows:

- 1 Unscrew the housing cover
- 2 Place the indicating/adjustment module in the desired position on the electronics (you can choose any one of four different positions - each displaced by 90°)
- 3 Press the indicating and adjustment module onto the electronics and turn it to the right until it snaps in.
- 4 Screw housing cover with inspection window tightly back on

Removal is carried out in reverse order.

The indicating/adjustment module is powered by the sensor, an additional connection is not necessary.



Fig. 21: Installation of the indicating/adjustment module



Note:

If you intend to retrofit OPTISOUND 3040 C with an indicating/adjustment module for continuous measured value indication, a higher cover with an inspection glass is required.

6.3 Adjustment system

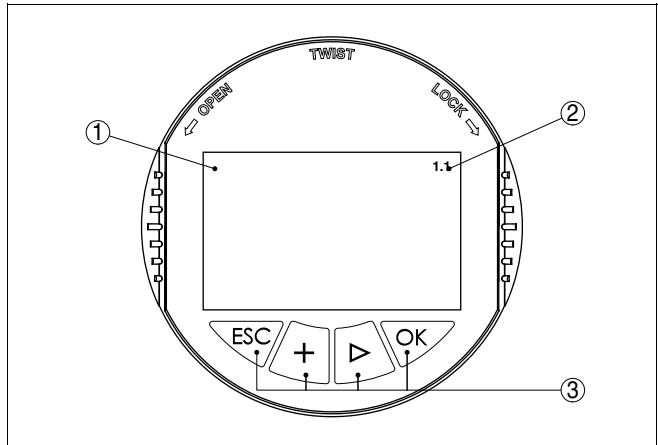

Fig. 22: Indicating and adjustment elements

- 1 LC display
- 2 Indication of the menu item number
- 3 Adjustment keys

Key functions

- **[OK]** key:
 - move to the menu overview
 - confirm selected menu
 - edit parameter
 - save value
- **[->]** key to select:
 - menu change
 - list entry
 - editing position
- **[+]** key:
 - modify value of a parameter
- **[ESC]** key:
 - interrupt input
 - jump to the next higher menu

Adjustment system

The sensor is adjusted via the four keys of the indicating and adjustment module. The LC display indicates the individual menu items. The functions of the individual keys are shown in the above illustration. Approx. 10 minutes after the last pressing of a key, an automatic reset to measured value indication is triggered. Any values not confirmed with **[OK]** will not be saved.

6.4 Setup procedure

Address setting HART-Multi-drop

In HART-Multidrop mode (several sensors on one input) the address must be set before continuing with the parameter adjustment. You will find a detailed description in the operating instructions manual of the indicating/adjustment module.

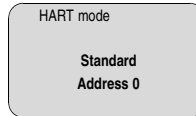

Parameter adjustment

Because OPTISOUND 3040 C is a distance measuring instrument, its primary task is to measure the distance from the sensor to the product surface. In order to indicate the actual filling level, the measured distance must be allocated to a specific height percentage. To make this adjustment, the full and empty distances in the vessel are entered. If these values are not known, it is also possible to carry out the adjustment with other distances, e.g. 10 % and 90 %. The origin of these distance values is always the lower edge of the flange (with flange versions) or the lower edge of the transducer (all other versions).

The actual level is then calculated on the basis of these entered values. At the same time, the operating range of the sensor is limited from maximum range to the requested range.

The real product level during this adjustment is not important, because the min./max. adjustment is always carried out without changing the product level. These settings can be made ahead of time without the instrument having to be installed.

In the main menu item "Basic adjustment", the individual submenu items should be selected one after the other and provided with the correct parameter values.

Start your parameter adjustment with the following menu items of the basic adjustment:

Carrying out min. adjustment

Proceed as follows:

- 1 Move from the measured value display to the main menu by pushing **[OK]**.

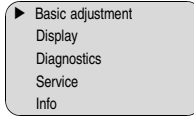

- 2 Select the menu item "*Basic adjustment*" with **[→]** and confirm with **[OK]**. Now the menu item "*Min. adjustment*" is displayed.

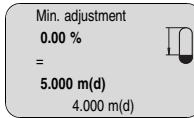

- 3 Prepare the % value for editing with **[OK]** and set the cursor to the requested position with **[→]**. Set the requested percentage value with **[+]** and save with **[OK]**. The cursor jumps now to the distance value.
- 4 Enter the appropriate distance value in m (corresponding to the percentage value) for the empty vessel (e.g. distance from the sensor to the vessel bottom).
- 5 Save the settings with **[OK]** and move to "Max. adjustment" with **[→]**.

Carrying out max. adjustment Proceed as follows:

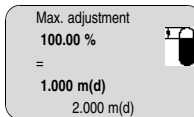

- 1 Prepare the % value for editing with **[OK]** and set the cursor to the requested position with **[→]**. Set the requested percentage value with **[+]** and save with **[OK]**. The cursor jumps now to the distance value.
- 2 Enter the appropriate distance value in m (corresponding to the percentage value) for the full vessel. Keep in mind that the max. level must lie below the dead band.
- 3 Save the settings with **[OK]** and move to "Medium selection" with **[→]**.

Medium selection

Each product has different reflective properties. In addition, there are various interfering factors which have to be taken into account: agitated product surfaces and foam generation (with liquids); dust generation, material cones and echoes from the

vessel wall (with solids). To adapt the sensor to these different conditions, you should first select in this menu item "*Liquid*" or "*Solid*".

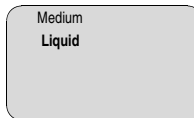

With solids, you can also choose between "*Powder/Dust*", "*Granular/Pellets*" or "*Ballast/Pebbels*".

Through this additional selection, the sensor is adapted perfectly to the product and measurement reliability, particularly in products with bad reflective properties, is considerably increased.

Enter the requested parameter via the appropriate keys, save your settings and jump to the next menu item with the **[→]** key.

Vessel shape

Apart from the medium, the shape of the vessel can also influence the measurement. To adapt the sensor to these conditions, this menu item offers (depending on either liquid or solid is detected) different options. For *Liquid* these are *Storage tank*, *Stilling tube*, *Open vessel* or *Stirred vessel*, for *Solid* *Silo* or *Bunker*.

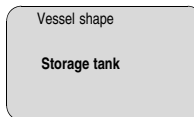

Enter the requested parameter via the appropriate keys, save your settings and jump to the next menu item with the **[→]** key.

Damping

To suppress fluctuation in the measured value display, e.g. caused by a turbulent product surface, an integration time can be set. This time can be between 0 and 999 seconds. Please note that the reaction time of the entire measurement will be longer and the sensor will react to quick changes of the measured value with a corresponding delay. In general, a time of a few seconds is sufficient to smooth the measured value display.

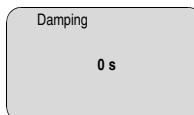

Enter the requested parameter via the appropriate keys, save your settings and jump to the next menu item with the **[→]** key.

Linearization curve

A linearization is necessary for all vessels in which the vessel volume does not increase linearly with the level – e.g. in a cylindrical or spherical tank – and the indication or output of the volume is requested. Corresponding linearization curves are preprogrammed for these vessels. They represent the correlation between the level percentage and vessel volume. By activating the appropriate curve, the volume percentage of the vessel is displayed correctly. If the volume should not be displayed in percent but e.g. in l or kg, a scaling can be also set in the menu item "Display".

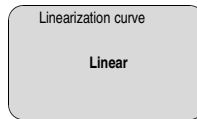

Enter the requested parameter via the appropriate keys, save your settings and jump to the next menu item with the **[→]** key.

Sensor-TAG

In this menu item you can enter an unambiguous designation for the sensor, e.g. the measurement loop name or the tank or product designation. In digital systems and in the documentation of larger plants, a singular designation should be entered for exact identification of individual measuring sites.

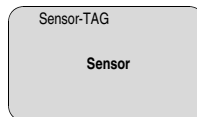

With this menu item, the Basic adjustment is finished and you can now jump to the main menu with the **[ESC]** key.

False signal suppression

High sockets or vessel installations, such as e.g. struts or agitators as well as buildup and weld joints on the vessel walls cause interfering reflections which can impair the measurement. A false signal suppression detects, marks and saves these false signals, so that they are no longer taken into account for the level measurement. This false signal suppression should be created with empty vessel so that all potential interfering reflections will be detected.

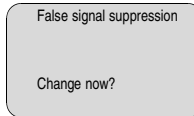

Proceed as follows:

- 1 Move from the measured value display to the main menu by pushing **[OK]**.
- 2 Select the menu item "Service" with **[->]** and confirm with **[OK]**. Now the menu item "False signal suppression" is displayed.
- 3 Confirm "False signal suppression - Change now" with **[OK]** and select in the below menu "Create new". Enter the actual distance from the sensor to the product surface. All false signals in this area are detected by the sensor and saved after confirming with **[OK]**.



Note:

Check the distance to the product surface, because if an incorrect (too large) value is entered, the existing level will be saved as false signal. The filling level would then no longer be detectable in this area.

Optional settings

Additional adjustment and diagnosis options such as e.g. scaling, simulation or trend curve presentation are shown in the following menu schematic. You will find a detailed description of these menu items in the operating instructions manual of the indicating and adjustment module.

6.5 Menu schematic

Basic adjustment

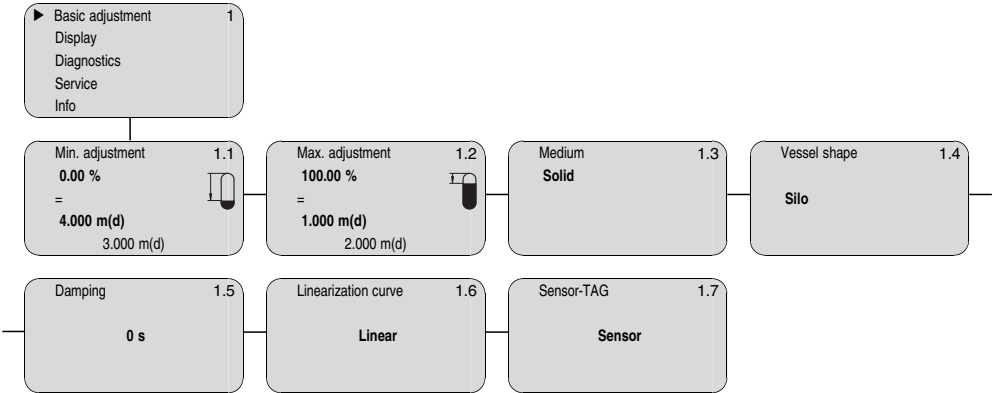

Display

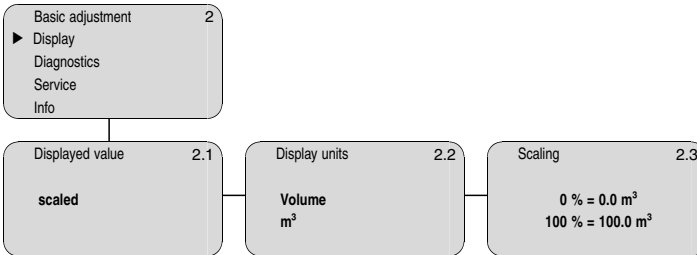

Diagnostics

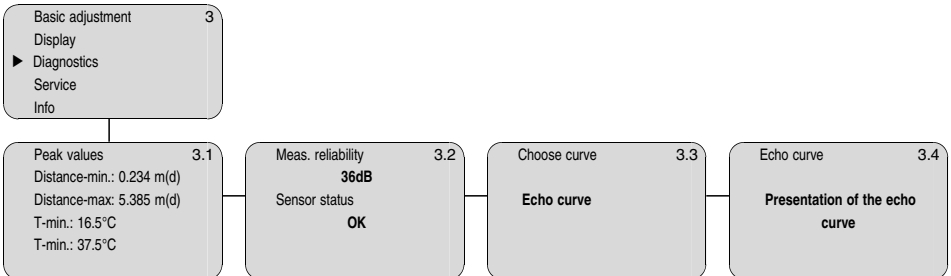

Service

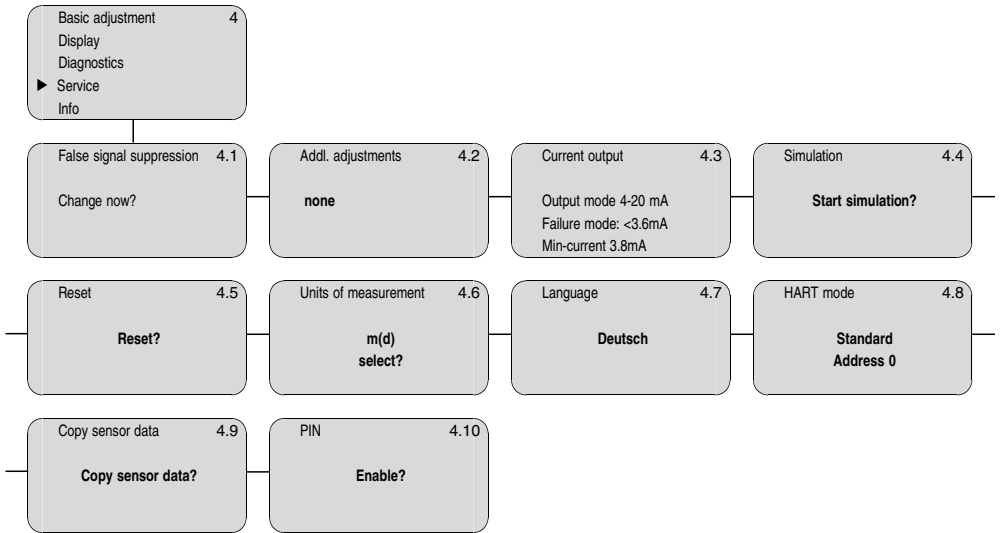

Info

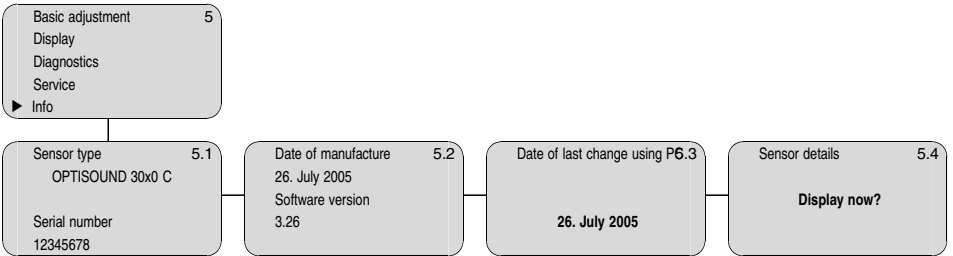

7 Maintenance and fault rectification

7.1 Maintenance

When used as directed in normal operation, OPTISOUND 3040 C is completely maintenance-free.

7.2 Fault rectification

Causes of malfunction

OPTISOUND 3040 C offers maximum reliability. Nevertheless faults can occur during operation. These may be caused by the following, e.g.:

- Sensor
- Process
- Power supply
- Signal processing.

Fault rectification

The first measures to be taken are to check the output signal and evaluate fault messages via the indicating/adjustment module. The procedure is described below.

Checking the 4 ... 20 mA signal

Connect a hand-held multimeter with a suitable measuring range acc. to the wiring plan.

? 4 ... 20 mA signal not stable

- level fluctuations

→ set integration time via the indicating/adjustment module

? 4 ... 20 mA signal missing

- wrong connection

→ Check connection acc. to chapter "*Connection procedure*" and correct, if necessary, acc. to chapter "*Wiring plans*"

- no power supply

→ check cables for line break, repair, if necessary

- load resistance too high

→ check and adapt, if necessary

- ? Current signal greater than 22 mA or less than 3.6 mA
 - Electronics module defective
 - Exchange instrument or return it for repair



Fault messages via the indicating/adjustment module

In Ex applications, the regulations for the wiring of intrinsically safe circuits must be observed.

- ? E013
 - no measured value available
 - sensor in boot phase
 - sensor does not find an echo, e.g. because of faulty installation or incorrect parameter adjustment
- ? E017
 - adjustment span too small
 - Carry out a fresh adjustment and increase the distance between min. and max. adjustment
- ? E036
 - no operable sensor software
 - carry out a software update or return instrument for repair
- ? E041
 - hardware error, electronics defective
 - Exchange instrument or return it for repair

7.3 Exchanging the electronics

If the electronics module is defective, it can be replaced by the user.



In Ex applications, only instruments and electronics modules with appropriate Ex approval may be used.

If there is no electronics module available on site, it can be ordered from the responsible Krohne agency.

7.4 Instrument repair

If a repair is necessary, please proceed as follows:

You can download a return form from our Internet homepage http://www.krohne-mar.com/fileadmin/media-lounge/PDF-Download/Specimen_e.pdf.

By doing this you help us carry out the repair quickly and without having to call back for needed information.

- Print and fill out one form per instrument
- Clean the instrument and pack it damage-proof
- Attach the completed form and possibly also a safety data sheet to the instrument.

8 Dismounting

8.1 Dismounting procedure

**Caution:**

During operation, individual cores of the transducer cable carry a voltage of approx. 70 V. Therefore dismount OPTISOUND 3040 C only in voltage-free condition.

Take note of chapters "*Mounting*" and "*Connecting to power supply*" and carry out the listed steps in reverse order.

8.2 Disposal

OPTISOUND 3040 C consists of materials which can be recycled by specialised recycling companies. We have purposely designed the electronic modules to be easily separable. Mark the instrument as scrap and dispose of it according to national government regulations (e.g. in Germany acc. to the EU Directive on Waste Electrical and Electronic Equipment, WEEE).

Materials: see "*Technical data*"

If you cannot dispose of the instrument properly, please contact us about disposal methods or return.

9 Supplement

9.1 Technical data

General data

Materials, wetted parts

– Flange	PP or Alu
– swivelling holder/flange	galvanized steel
– Transducer	PA (1.4301 with StEx)
– transducer diaphragm	316Ti (1.4571)

Materials, non-wetted parts

– Housing	Alu die-casting powder-coated
– Seal ring between housing and housing cover	silicone
– Inspection window in housing cover	Polycarbonate (UL746-C listed)
– Ground terminal	316Ti (1.4571/1.4435)
– transducer cable with separate version C and D	PUR (1.1082)

Weight²⁾

– compact with flange (version A)	5.6 ... 10.7 kg (12.3 ... 23.6 lbs)
– compact with swivelling holder (version B)	6.9 ... 9.7 kg (15.2 ... 21.4 lbs)
– separate with swivelling holder (version C)	7.5 ... 10.5 kg (16.5 ... 23.1 lbs)
– separate with threaded fitting (version D)	4.7 ... 6.9 kg (10.4 ... 15.2 lbs)

Output variable

Output signal	4 ... 20 mA/HART
Resolution	1.6 μ A
Fault signal	current output unchanged; 20.5 mA; 22 mA; <3.6 mA (adjustable)
Current limitation	22 mA
Load	max. 500 Ohm ³⁾
Integration time (63 % of the input variable)	0 ... 999 s, adjustable
Fulfilled NAMUR recommendation	NE 43

²⁾ Depending on size and process fitting material.

³⁾ With inductive load, ohmic share at least 25 Ohm/mH.

Input variable

Parameter

- | | |
|----------------------|---|
| – Version A | distance between lower edge of the flange and product surface |
| – version B, C and D | distance between lower edge of the transducer and product surface |

Dead zone

1 m (3.3 ft)

Measuring range

- | | |
|-----------|----------------------|
| – Liquids | up to 25 m (82 ft) |
| – Solid | up to 15 m (49.2 ft) |

Accuracy (similar to DIN EN 60770-1)

Reference conditions acc. to DIN EN 61298-1

- | | |
|------------------------|--|
| – Temperature | 18 ... +30°C (64 ... +86°F) |
| – Relative humidity | 45 ... 75 % |
| – Atmospheric pressure | 860 ... 1060 mbar (86 ... 106 kPa/
12.5 ... 15.4 psi) |

Characteristic curve deviation and measurement characteristics⁴⁾

- | | |
|--|--|
| Average temperature coefficient of the zero signal (temperature error electronics) | 0.06 %/10 K |
| Resolution, general | max. 1 mm |
| Ultrasonic frequency | 30 kHz |
| Interval | >2 s (dependent on the parameter adjustment) |
| Beam angle at -3 dB | 4° |
| Adjustment time ⁵⁾ | >3 s (dependent on the parameter adjustment) |
| Accuracy | better than 0.2 % or ±6 mm (see diagram) |

⁴⁾ Relating to the nominal range, incl. hysteresis and repeatability, determined acc. to the limit point method.

⁵⁾ Time to output the correct level (with max. 10 % deviation) after a sudden level change.

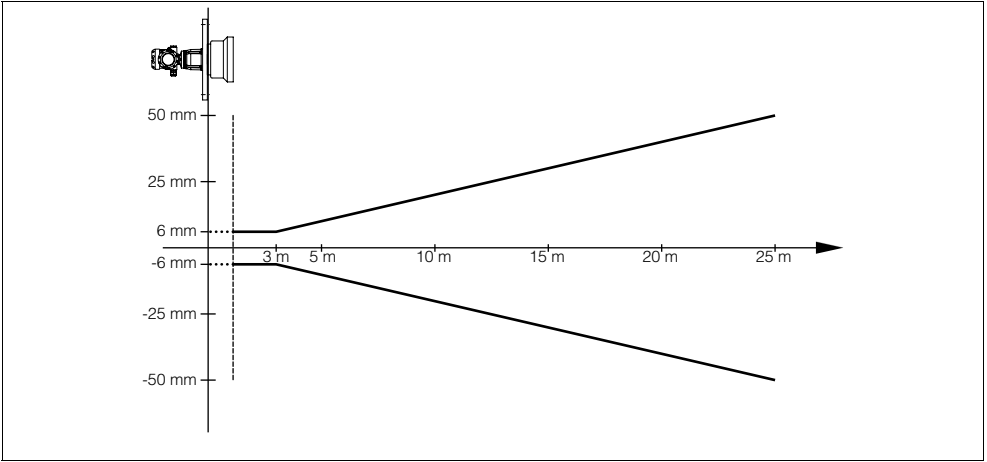

Fig. 23: Accuracy OPTISOUND 3040 C version A

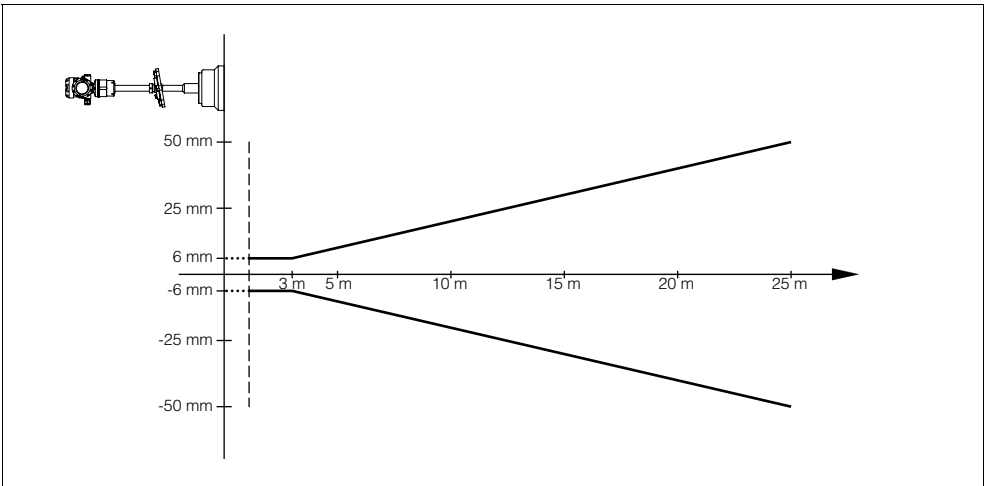

Fig. 24: Accuracy OPTISOUND 3040 C versions B, C, D

Ambient conditions

Ambient, storage and transport temperature

- without indicating/adjustment module -40 ... +80°C (-40 ... +176°F)
- the indicating/adjustment module -20 ... +70°C (-4 ... +158°F)

Process conditions

Vessel pressure	
– version A with PP flange	0 kPa (0 bar/0 psi)
– other versions	-20 ... 50 kPa (-0.2 ... 0.5 bar/-2.9 ... 7.3 psi)
Process temperature (transducer temperature)	-40 ... +80°C (-40 ... +176°F)
Vibration resistance	mechanical vibrations with 1 g in the frequency range 5 ... 200 Hz ⁶⁾

Electromechanical data

Cable entry	
– Double chamber housing	<ul style="list-style-type: none"> • 1x cable entry M20x1.5 (cable-\varnothing 5 ... 9 mm), 1x blind stopper M20x1.5 or: <ul style="list-style-type: none"> • 1x closing cap ½ NPT, 1x blind stopper ½ NPT
Spring-loaded terminals	for wire cross sections up to 2.5 mm ²
Transducer cable ⁷⁾	
– length	5 ... 300 m (16.4 ... 984.3 ft)
– Diameter	7.2 ... 7.6 mm

Indicating and adjustment module

Power supply and data transmission	through sensor via gold-plated sliding contacts (I ² C bus)
Indication	LC display in full dot matrix
Adjustment elements	4 keys
Protection	
– unassembled	IP 20
– mounted into the sensor without cover	IP 40
Materials	
– Housing	ABS
– Inspection window	Polyester foil

Supply voltage

Supply voltage	
– non-Ex and Exd instrument	20 ... 72 V DC, 20 ... 253 V AC, 50/60 Hz

⁶⁾ Tested acc. to the regulations of German Lloyd, GL directive 1

⁷⁾ With separate version C and D.

Power consumption max. 4 VA; 2.1 W

Electrical protective measures

Protection	IP 66/IP 67
Overvoltage category	III
Protection class	I

Approvals⁸⁾

ATEX	ATEX II 1/2D IP66 T
------	---------------------

⁸⁾ Deviating data with Ex applications: see separate safety instructions.

9.2 Dimensions

Housing

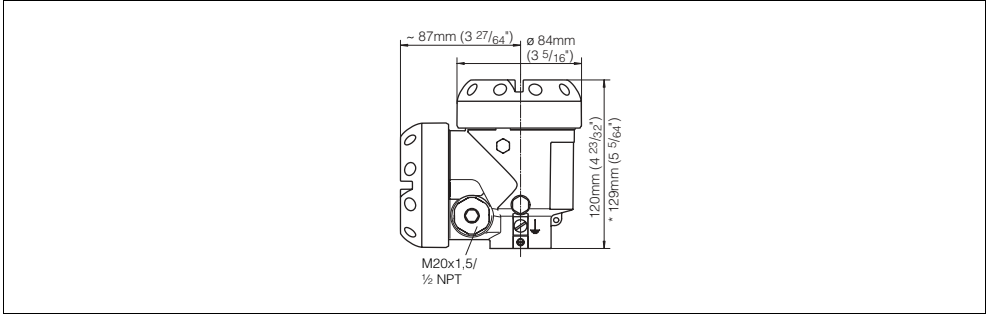

Fig. 25: Housing versions (with integrated indicating/adjustment module the housing height or width is increased by 9 mm / 0.35 in)

OPTISOUND 3040 CVersion A and B

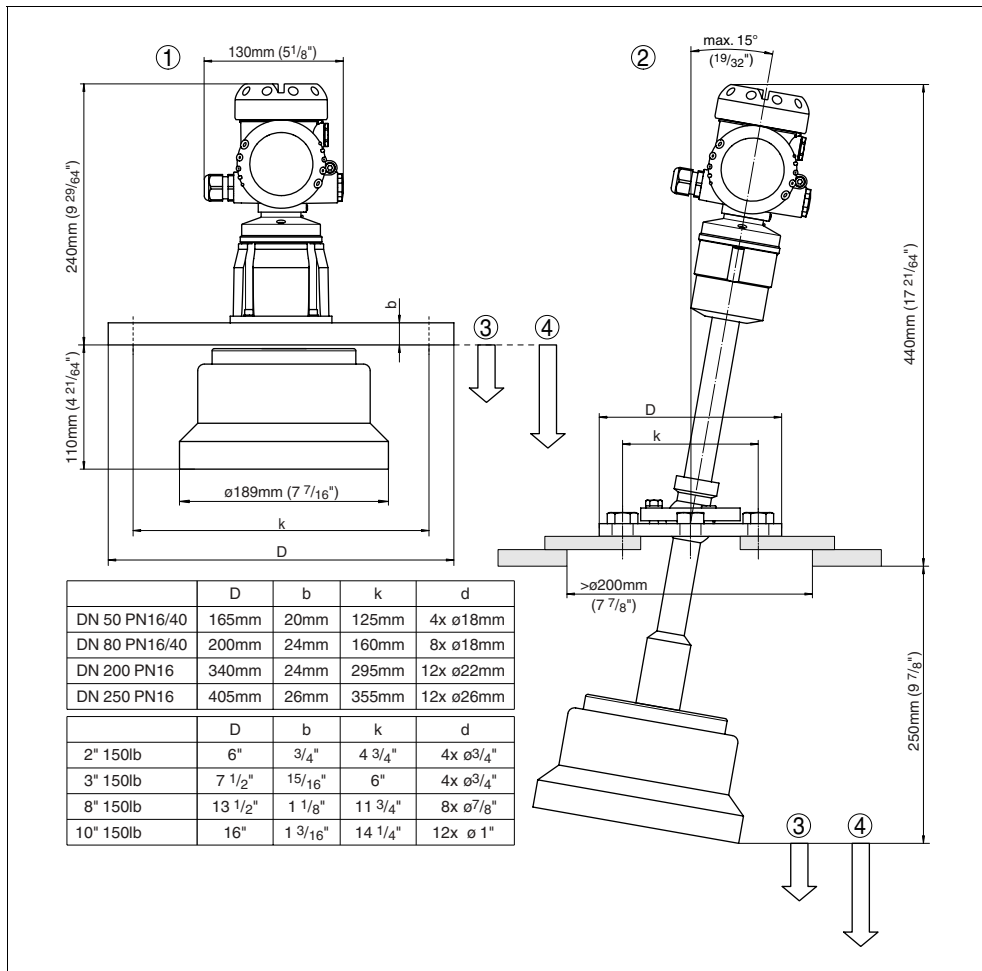

Fig. 26: OPTISOUND 3040 CVersion A and B

1 Version A

2 Version B

3 Dead zone: 1 m (3.3 ft)

4 Measuring range: with liquids up to 25 m (82 ft), with solids up to 15 m (49.2 ft)

OPTISOUND 3040 CVersion C and D

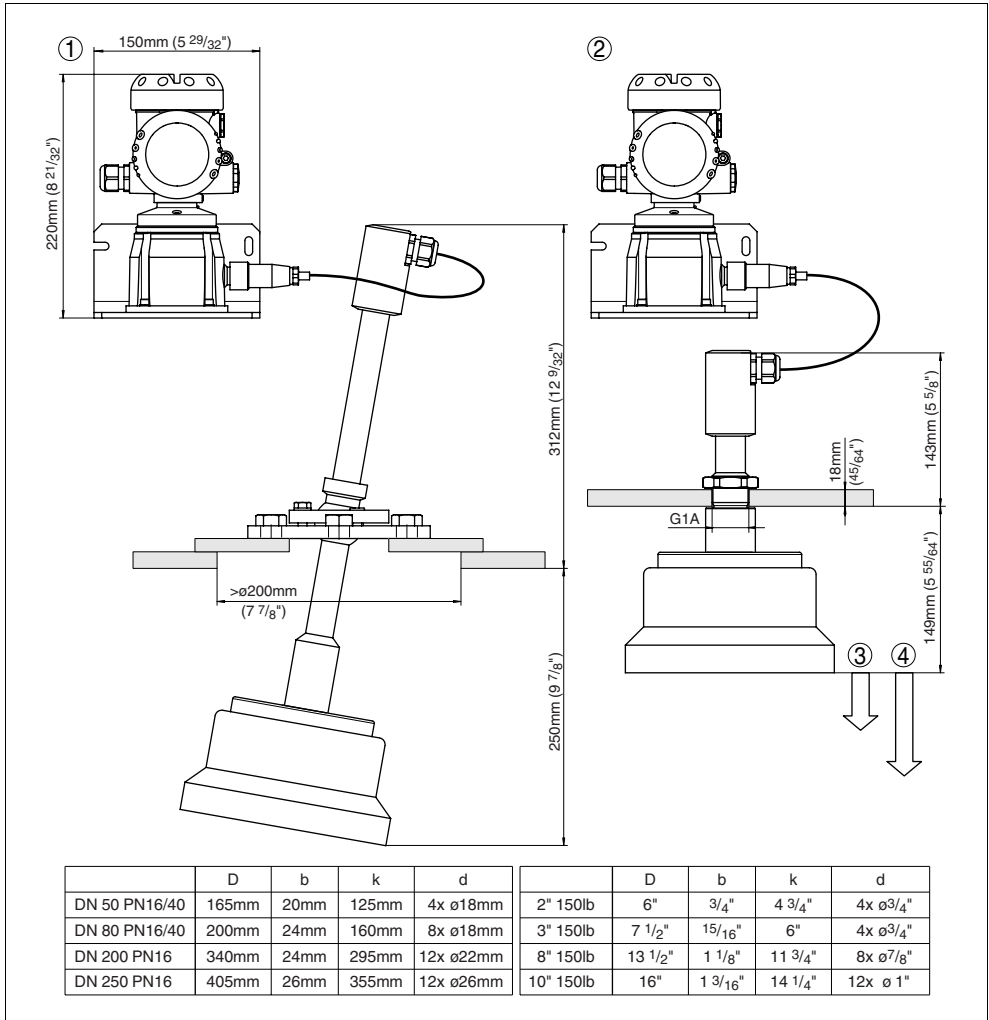

Fig. 27: OPTISOUND 3040 CVersion C and D

1 Version C

2 Version D

3 Dead zone: 1 m (3.3 ft)

4 Measuring range: with liquids up to 25 m (82 ft), with solids up to 15 m (49.2 ft)

9.3 CE declaration of conformity

CE declaration of conformity

CE

Konformitätserklärung

Declaration of conformity
Déclaration de conformité

KROHNE

Krohne S.A.S.
Les Oies BP 98
F-26103 Romans Cedex

erklärt in alleiniger Verantwortung, daß das Produkt / declare under
our sole responsibility that our product / déclare sous sa seule
responsabilité que le produit

OPTISOUND 3010 C, OPTISOUND 3020 C, OPTISOUND 3030 C
OPTISOUND 3040 C, OPTISOUND 3050 C
4...20mA HART-Vierleiter

auf das sich diese Erklärung bezieht, mit den folgenden Normen
übereinstimmt / to which this declaration relates is in conformity
with the following standards / auquel se réfère cette déclaration
est conforme aux normes

Emission / Emission / Emission → EN 61326 : 1997 / A1 : 1998 (Klasse A)
Immision / Susceptibility / Immission → EN 61326 : 1997 / A1 : 1998
EN 61010 – 1 : 2001

gemäß den Bestimmungen der Richtlinien / following the provision
of Directives / conformément aux dispositions des Directives

73/23 EWG
89/336 EWG

08.03.2005

I.V./p.p./P.O. Florian Stengle

Fig. 28: CE declaration of conformity

Subject to change without notice